



US 20140211142A1

(19) **United States**

(12) **Patent Application Publication**
KIM et al.

(10) **Pub. No.: US 2014/0211142 A1**
(43) **Pub. Date: Jul. 31, 2014**

(54) **LIQUID CRYSTAL DISPLAY HAVING
MULTIPLE PIXEL REGIONS FOR
IMPROVED TRANSMITTANCE**

Publication Classification

(71) Applicant: **Samsung Display Co., Ltd.,
Yongin-City (KR)**

(51) **Int. Cl.**
G02F 1/1343 (2006.01)
(52) **U.S. Cl.**
CPC **G02F 1/134336** (2013.01)
USPC **349/138**

(72) Inventors: **Hoon KIM**, Ansan-si (KR); **Su Jeong
KIM**, Seoul (KR); **Ki Chul SHIN**,
Seongnam-si (KR); **Dan Bi YANG**,
Gunpo-si (KR); **Jae-Hoon JUNG**,
Anyang-si (KR); **Min Ju HAN**, Seoul
(KR); **Ji Phyong HONG**, Pyeongtaek-si
(KR)

(57) **ABSTRACT**

A liquid crystal display according to an exemplary embodiment of the present invention includes: a first substrate; a first subpixel electrode positioned on the first substrate and configured to receive a first voltage; a second subpixel electrode positioned on the first substrate and configured to receive a second voltage; an insulating layer positioned between the first subpixel electrode and the second subpixel electrode; a second substrate facing the first substrate; and a common electrode positioned on the second substrate. A portion of the first subpixel electrode and a portion of the second subpixel electrode overlap each other with the insulating layer interposed therebetween, and a difference between the first voltage and a common voltage is larger than a difference between the second voltage and the common voltage.

(73) Assignee: **Samsung Display Co., Ltd.,
Yongin-City (KR)**

(21) Appl. No.: **14/090,593**

(22) Filed: **Nov. 26, 2013**

(30) **Foreign Application Priority Data**

Jan. 30, 2013 (KR) 10-2013-0010639

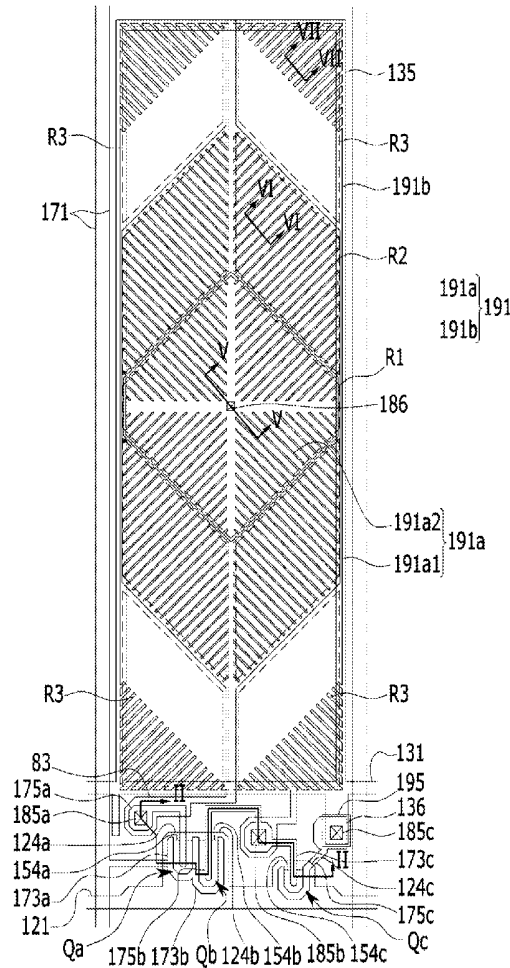

FIG. 1

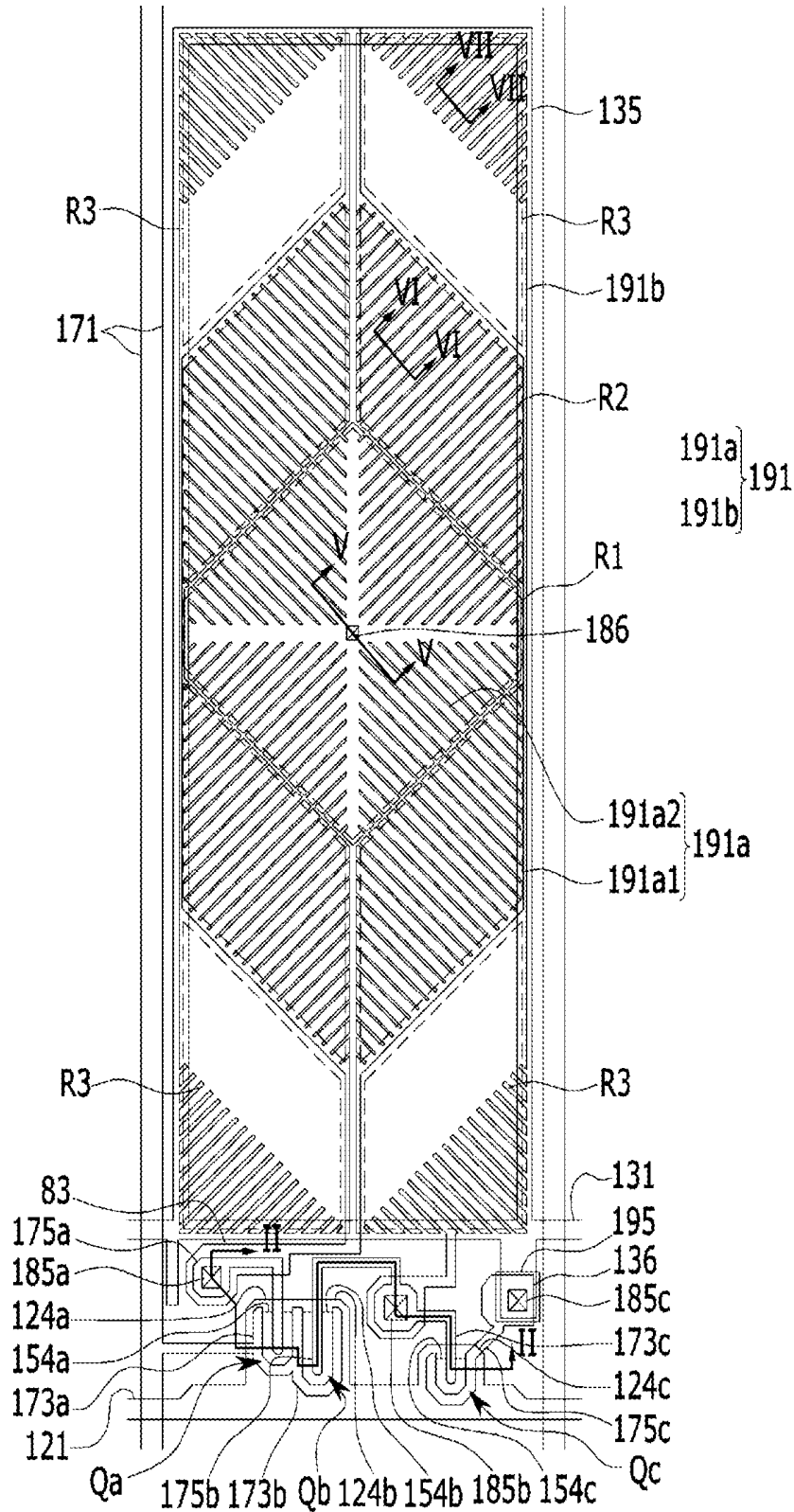

FIG. 3

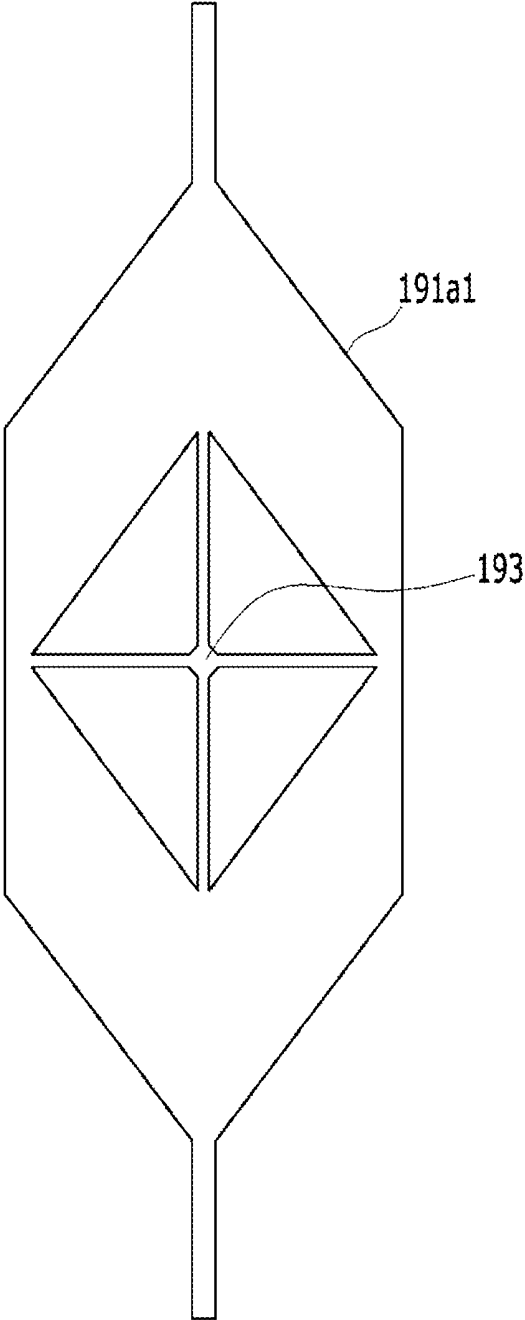

FIG. 4

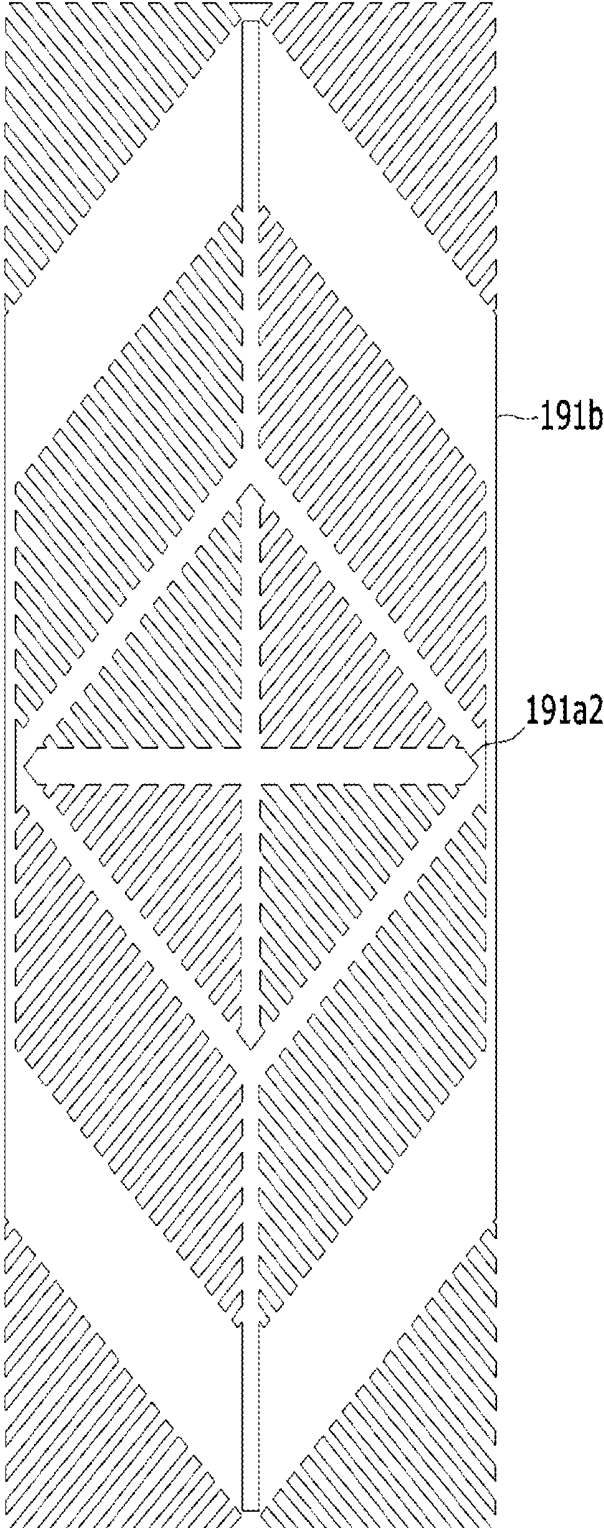

FIG. 5

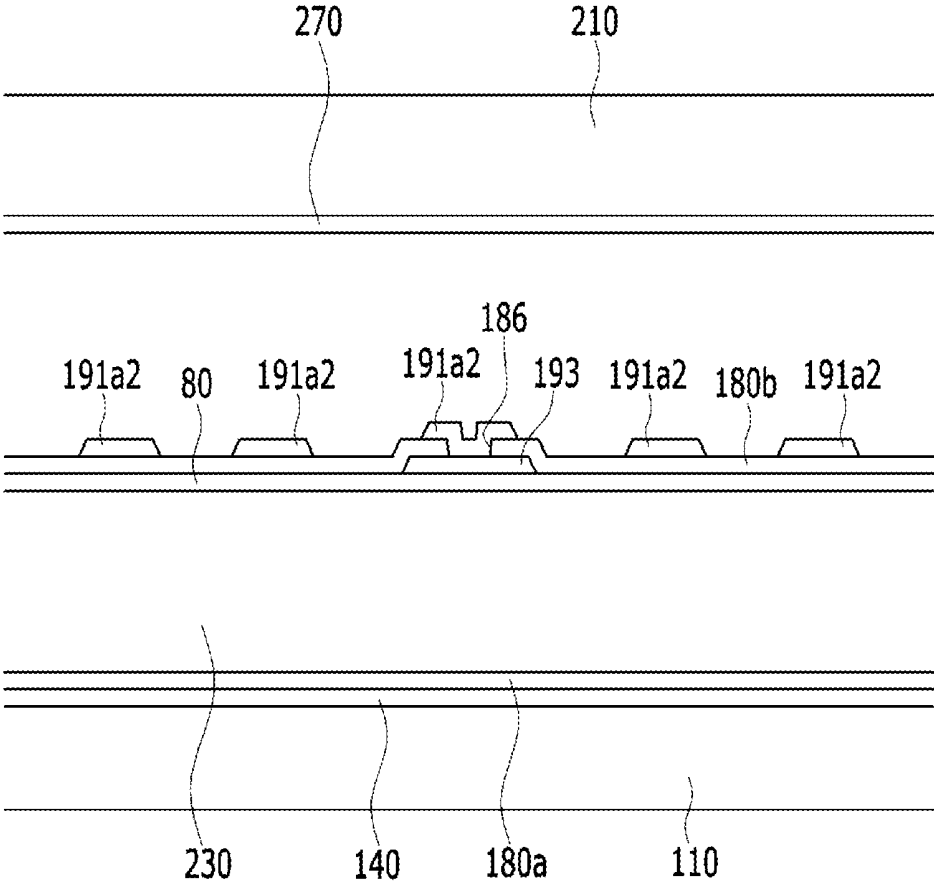

FIG. 7

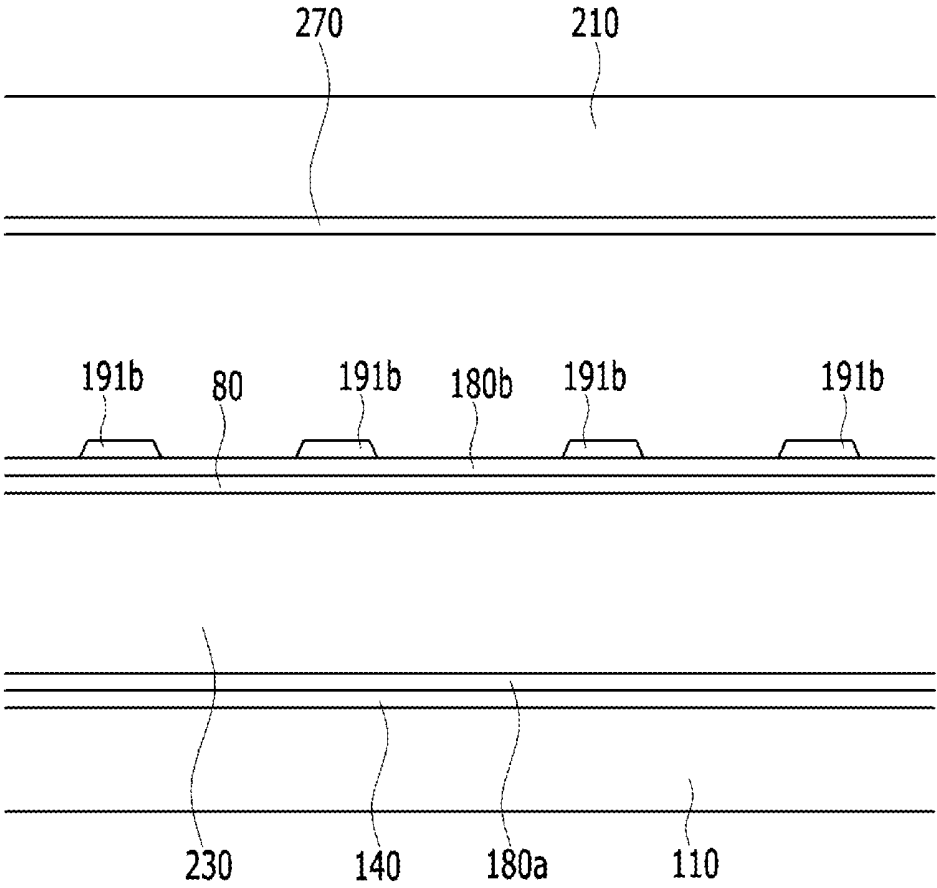

FIG. 8

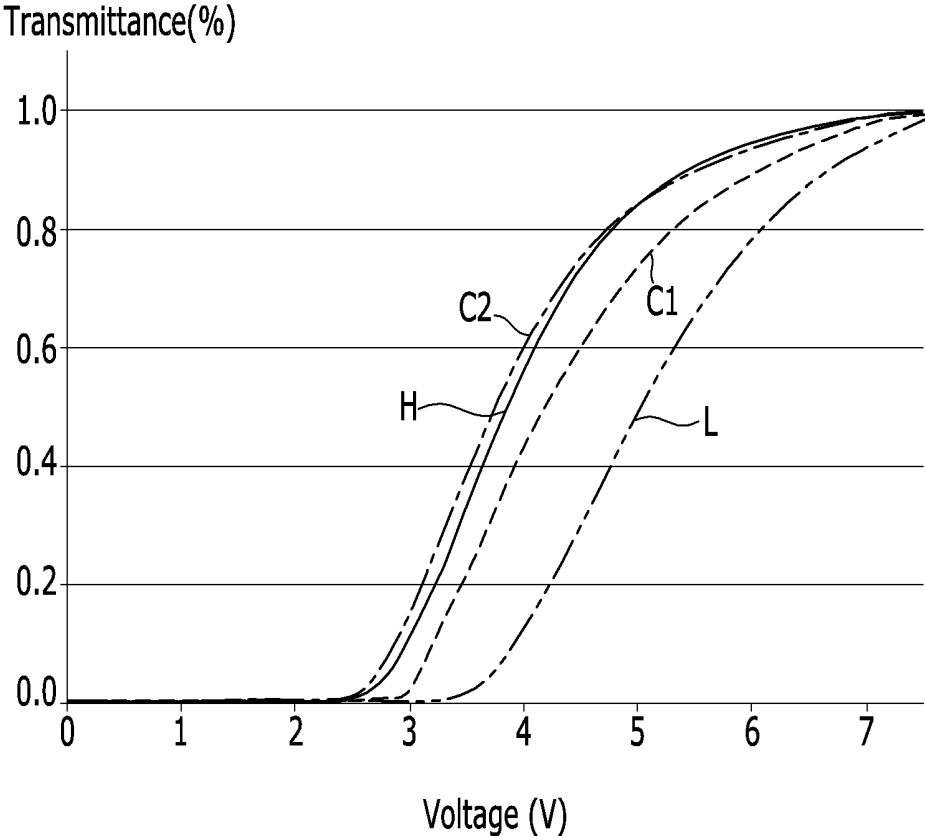

FIG. 9

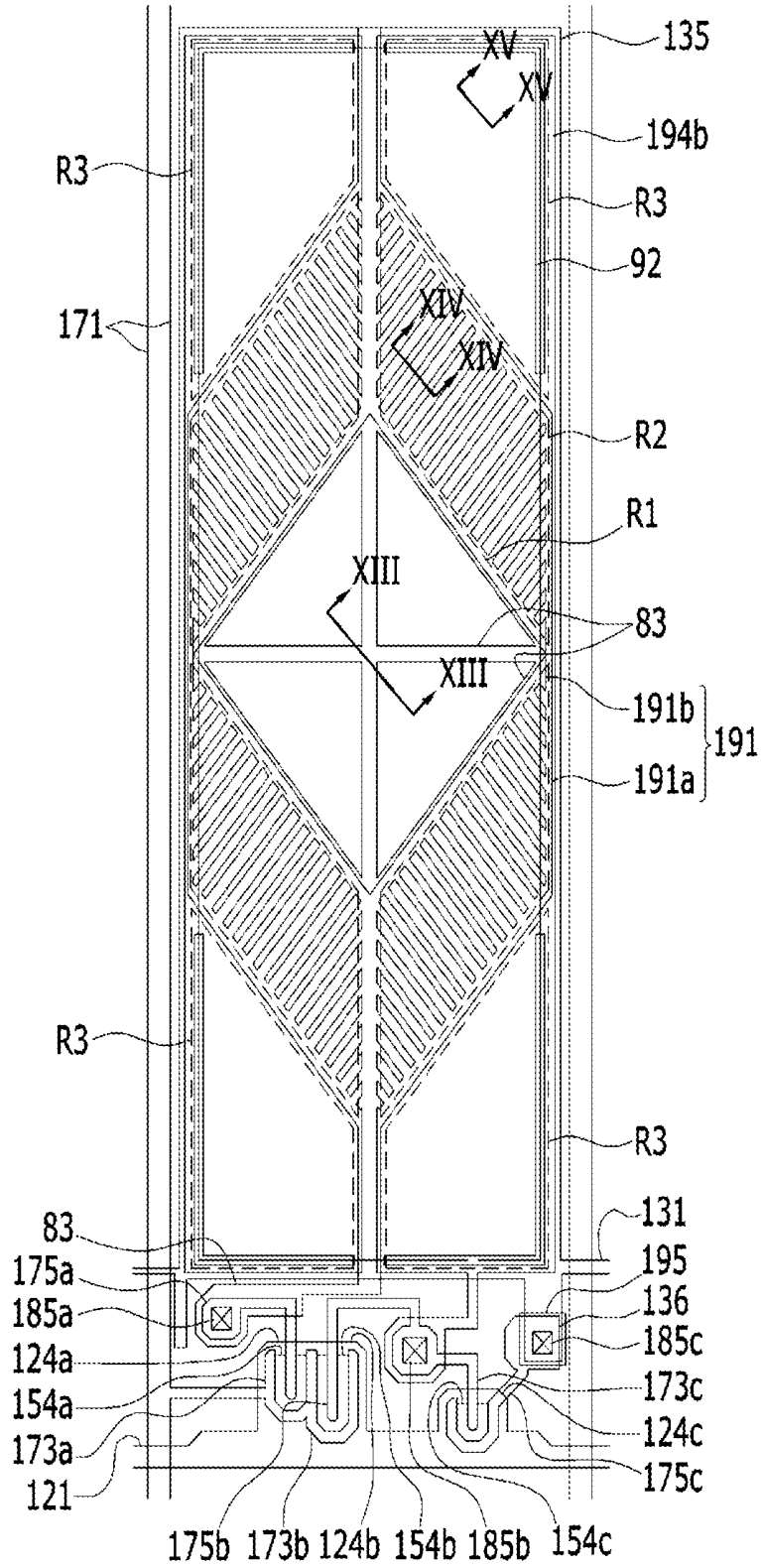

FIG. 10

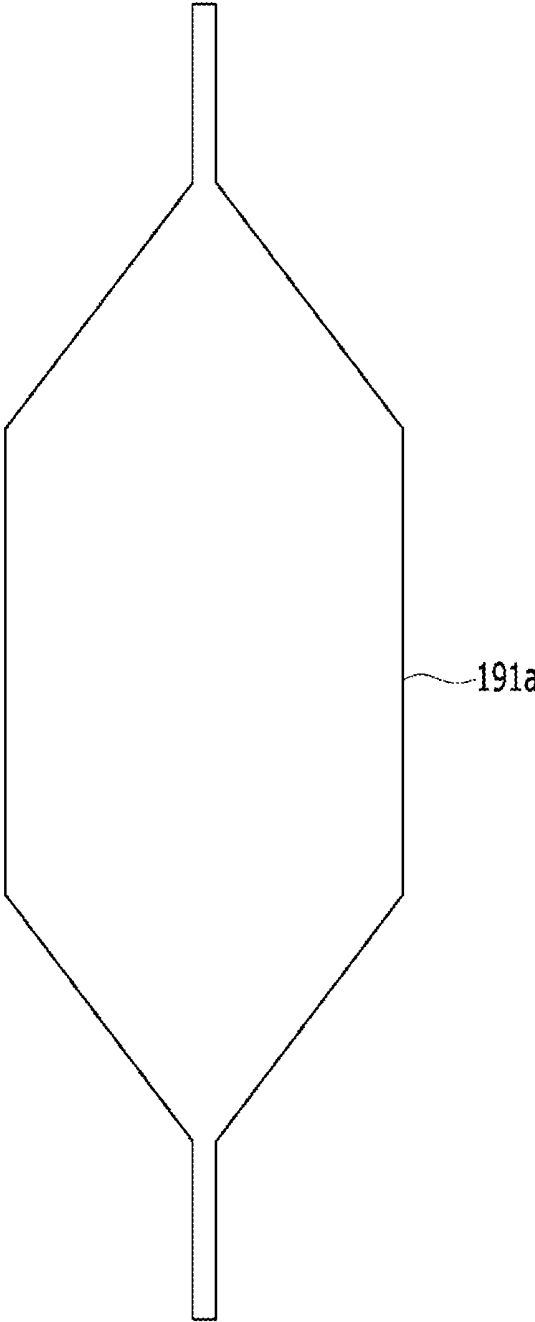

FIG. 11

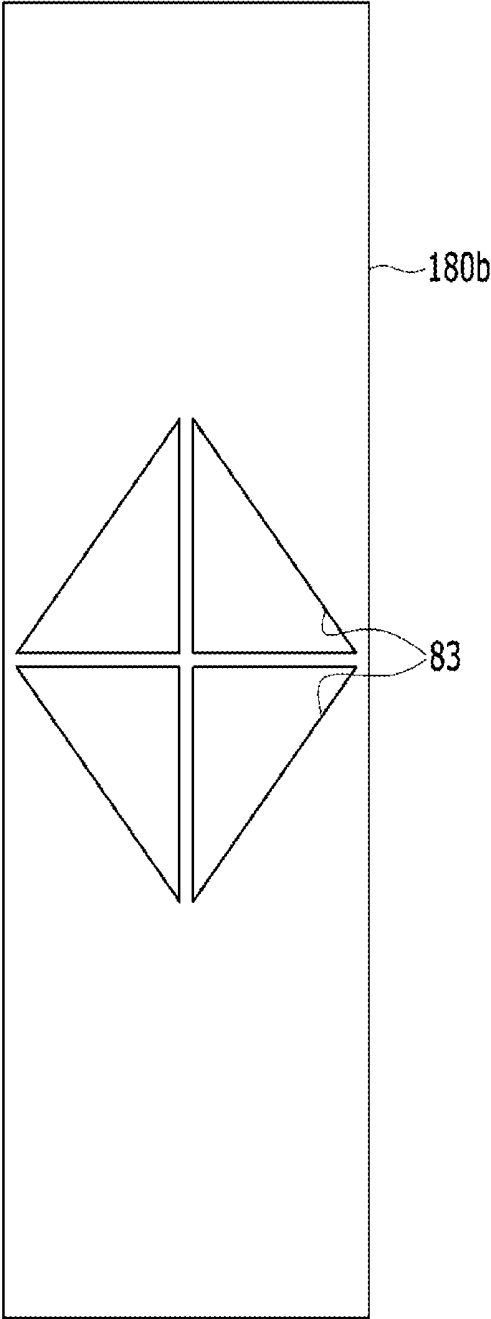

FIG. 12

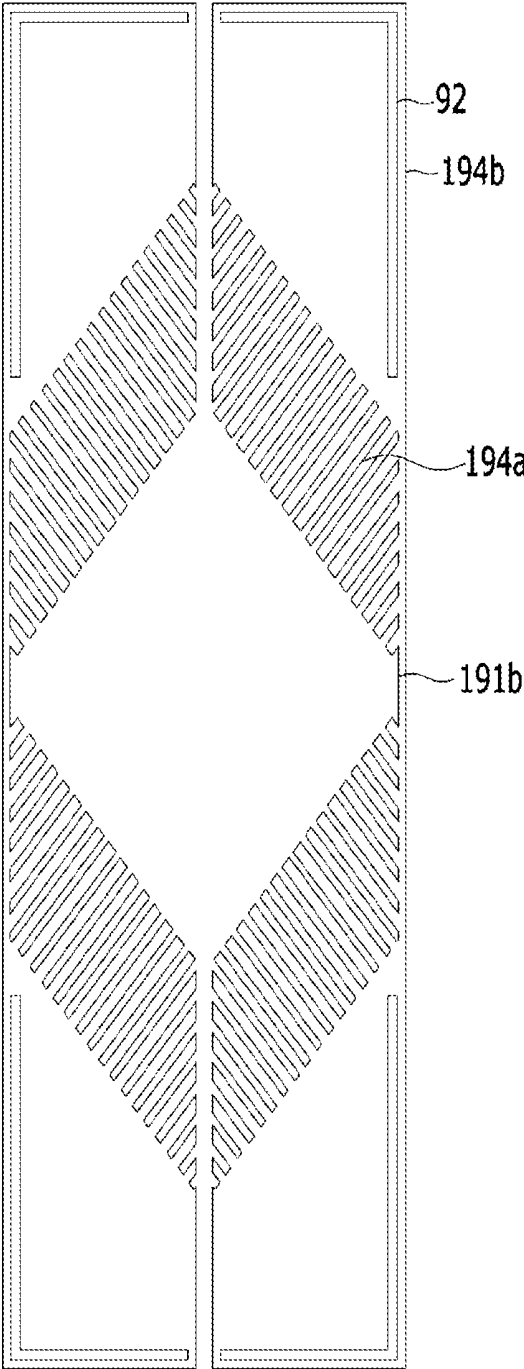

FIG. 13

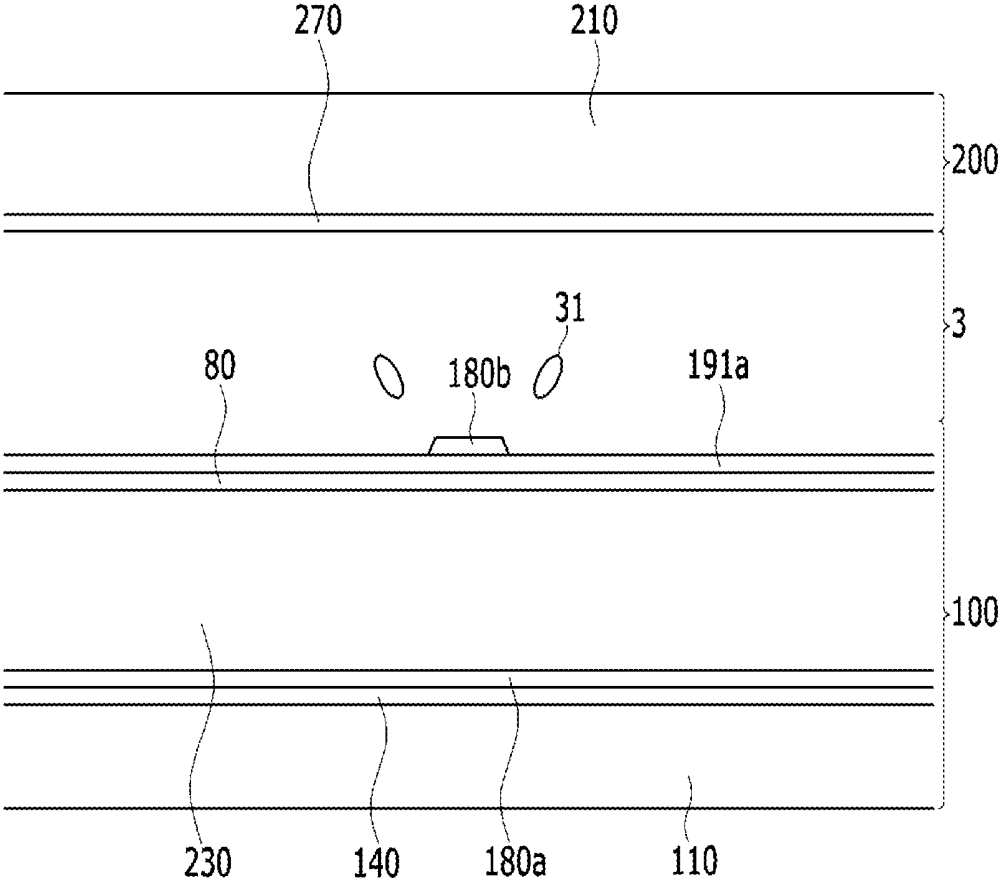

FIG. 14

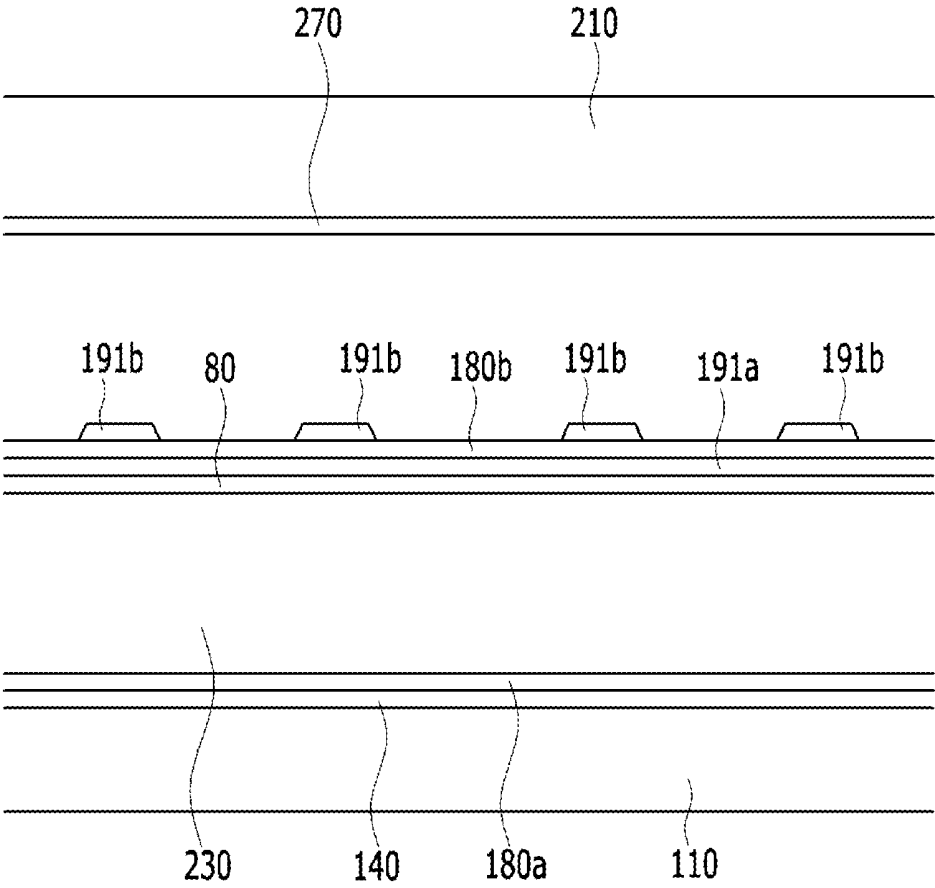

FIG. 15

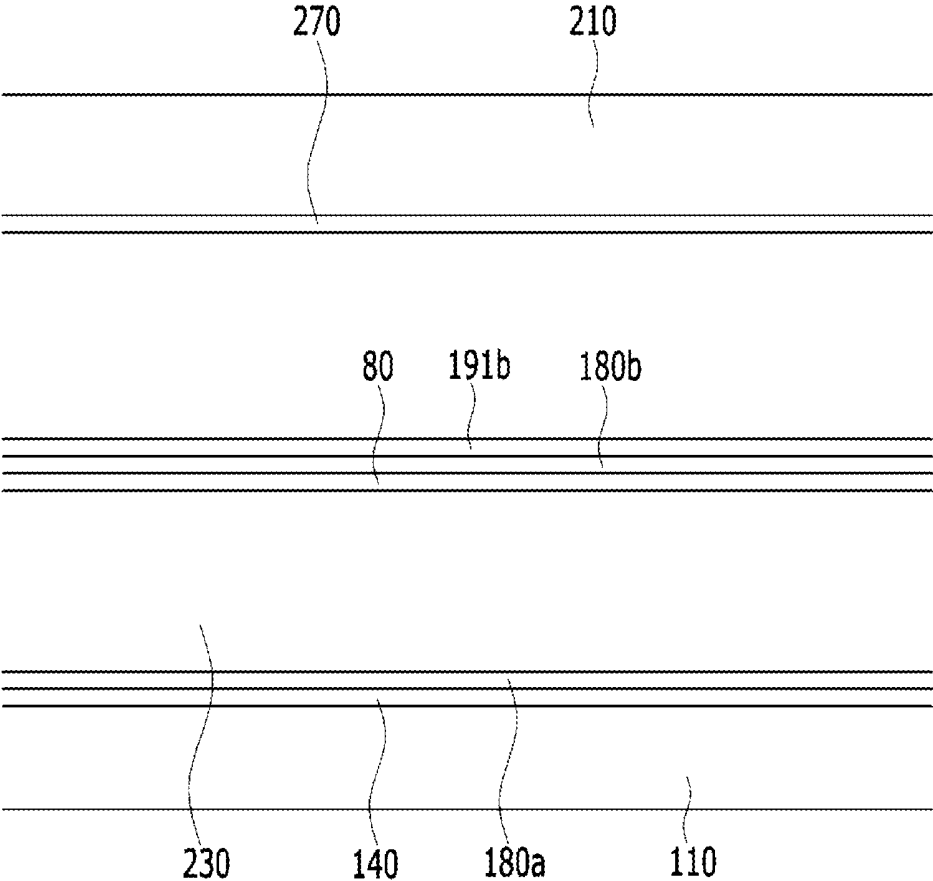

FIG. 16

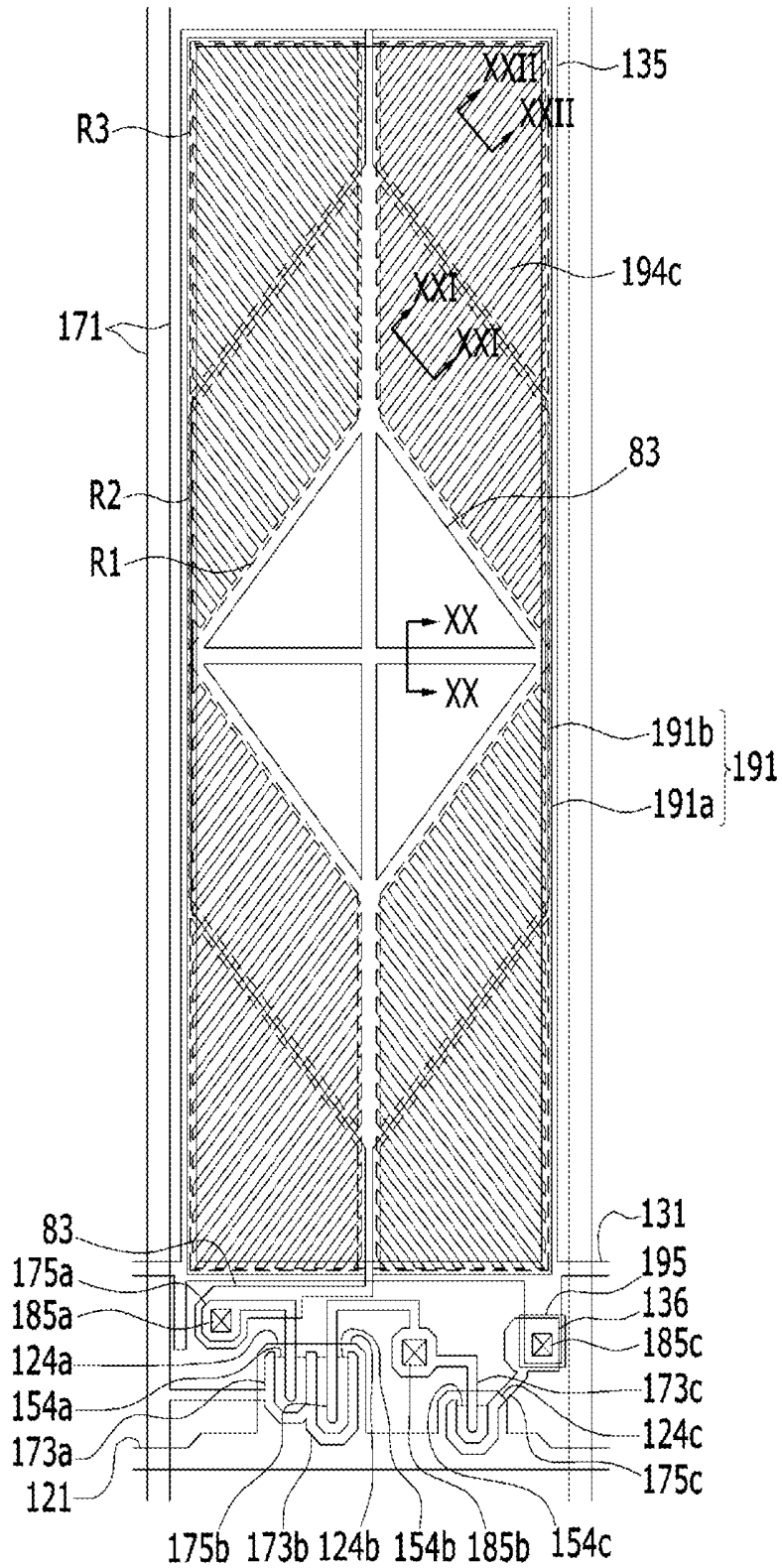

FIG. 17

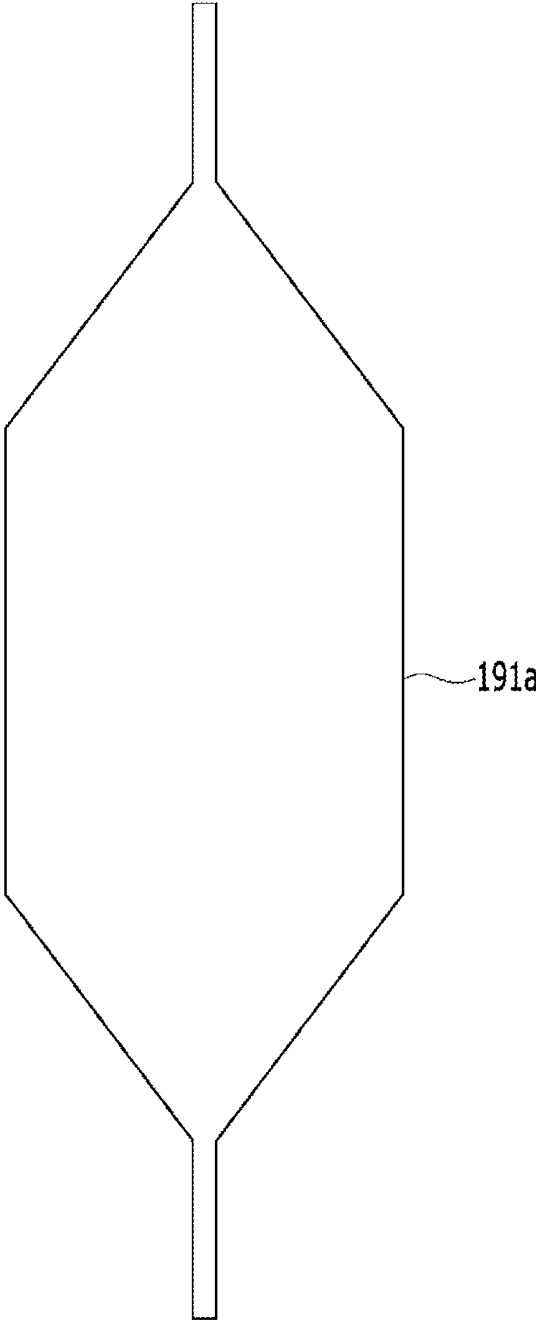

FIG. 18

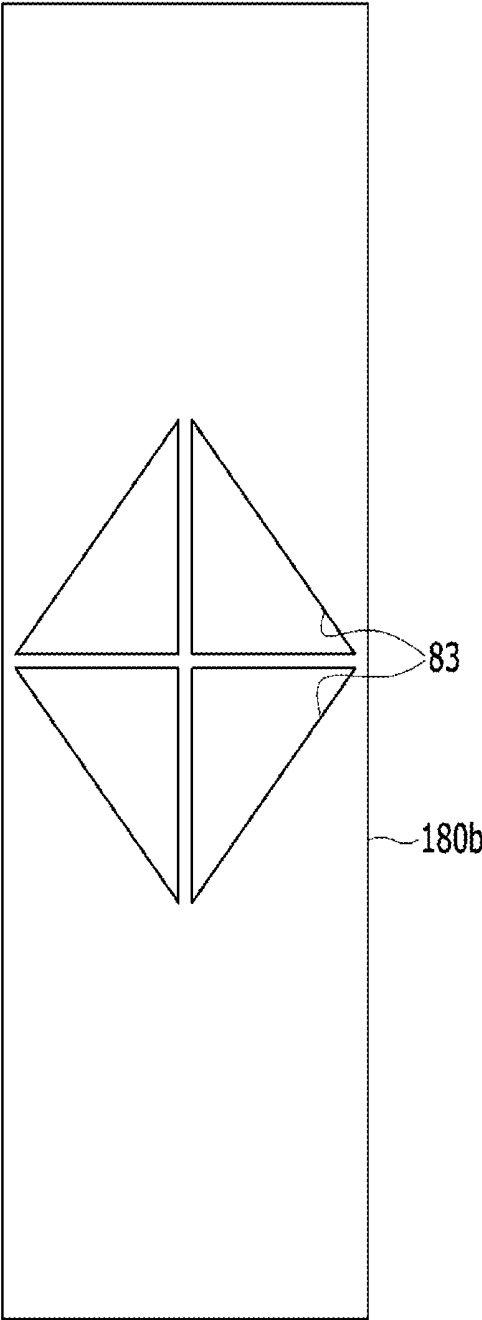

FIG. 19

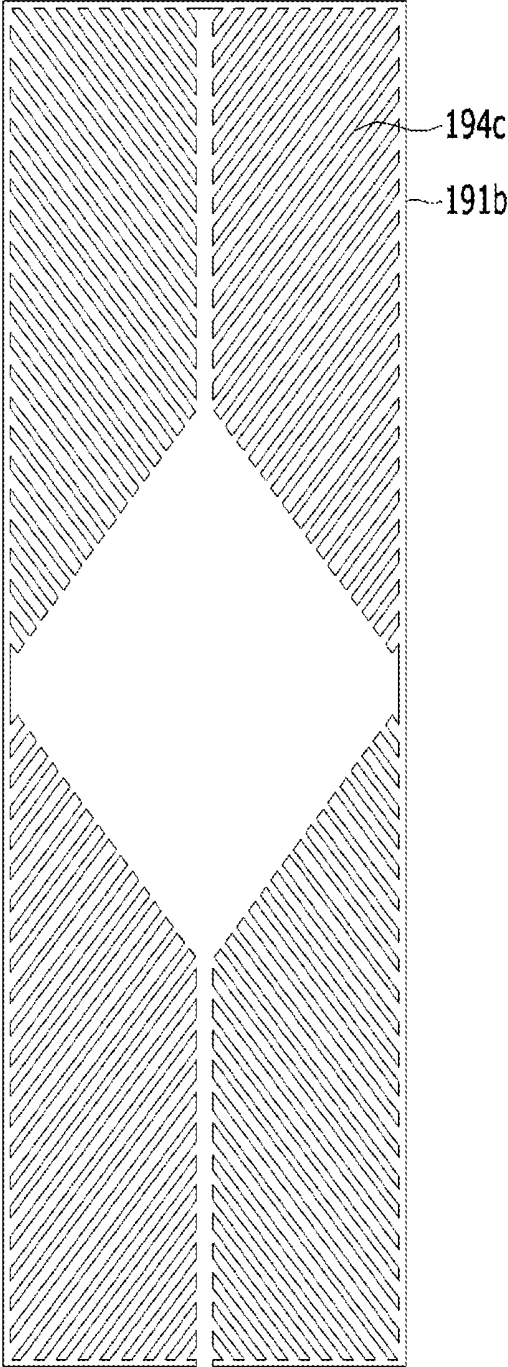

FIG. 20

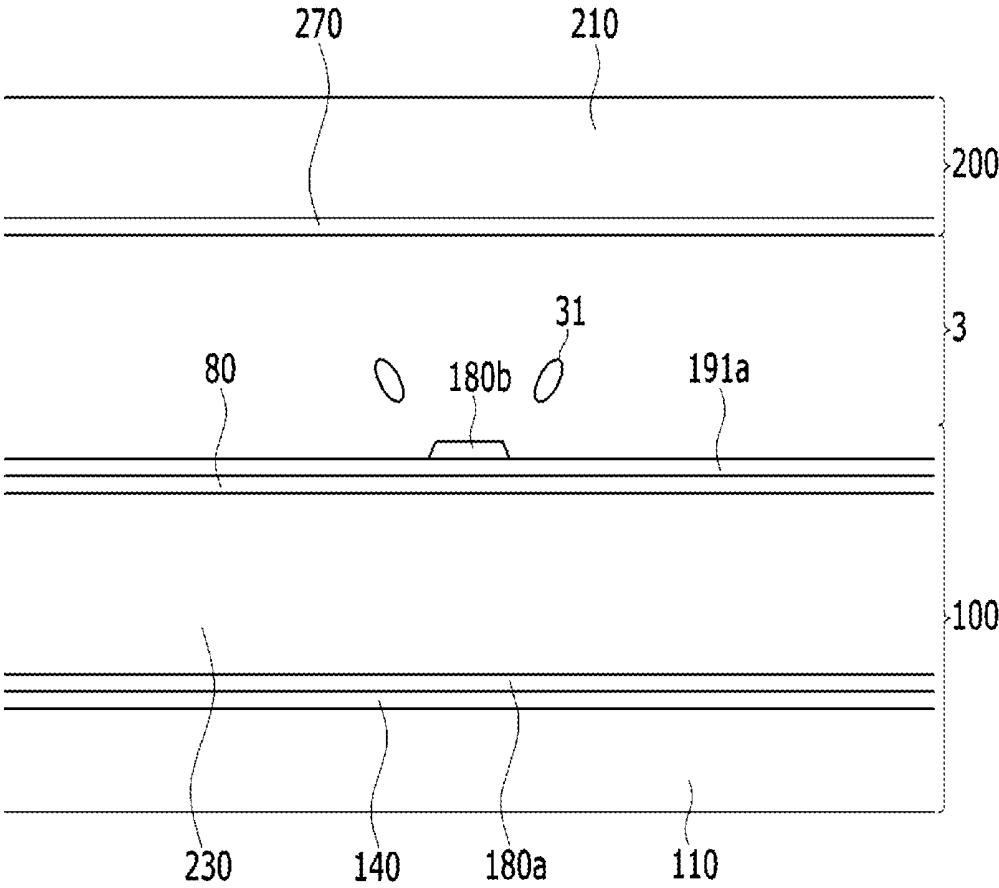

FIG. 21

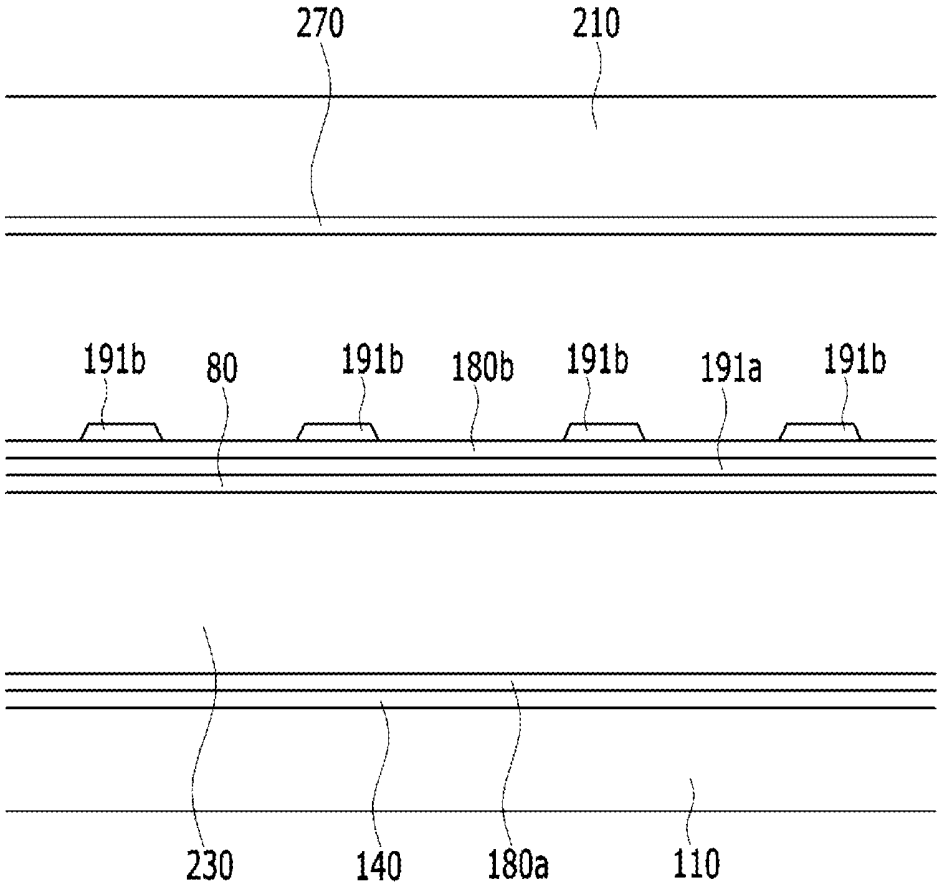

FIG. 22

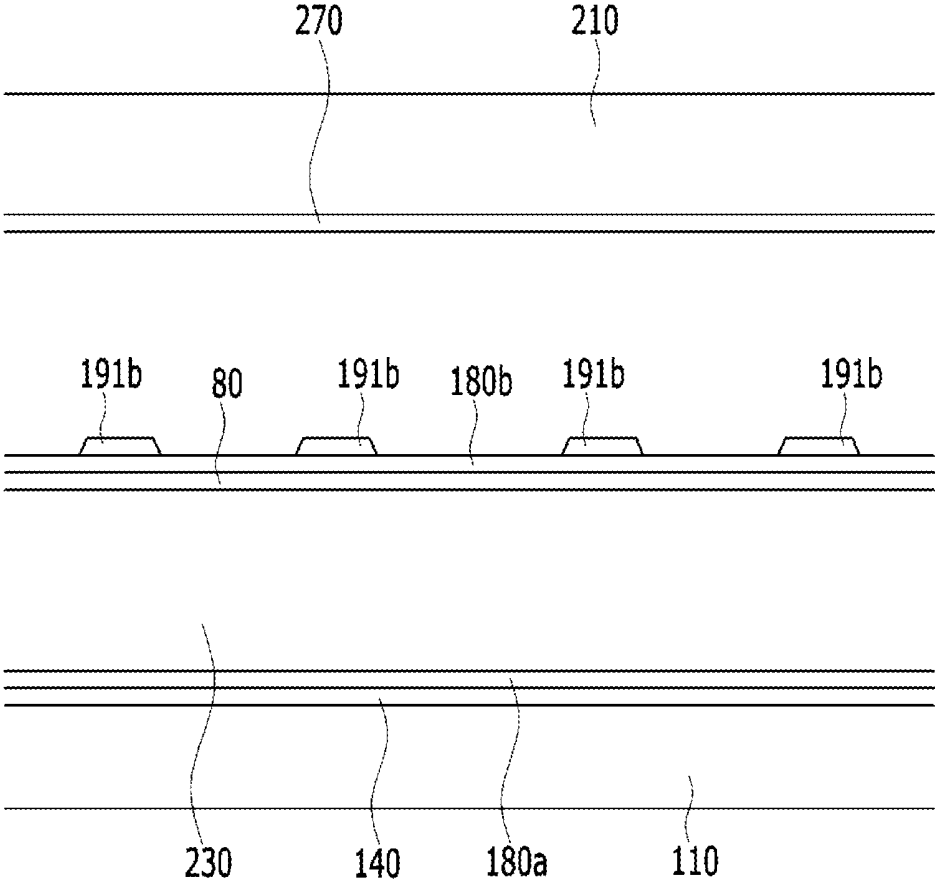

FIG. 23

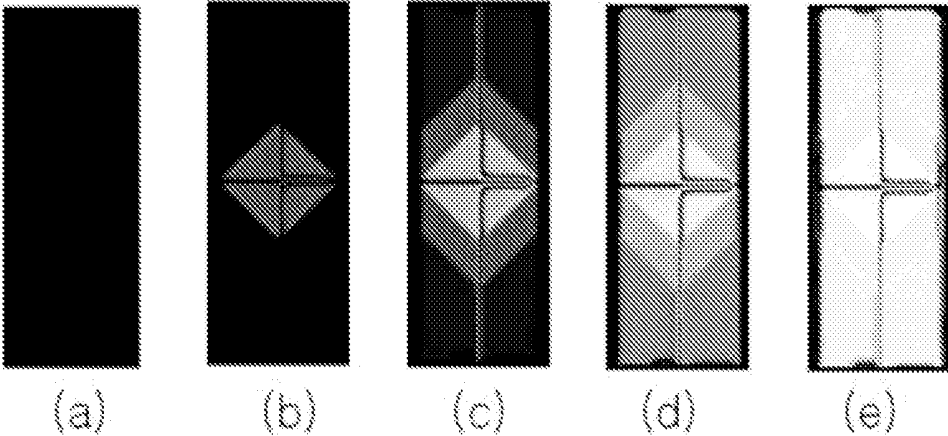

FIG. 24

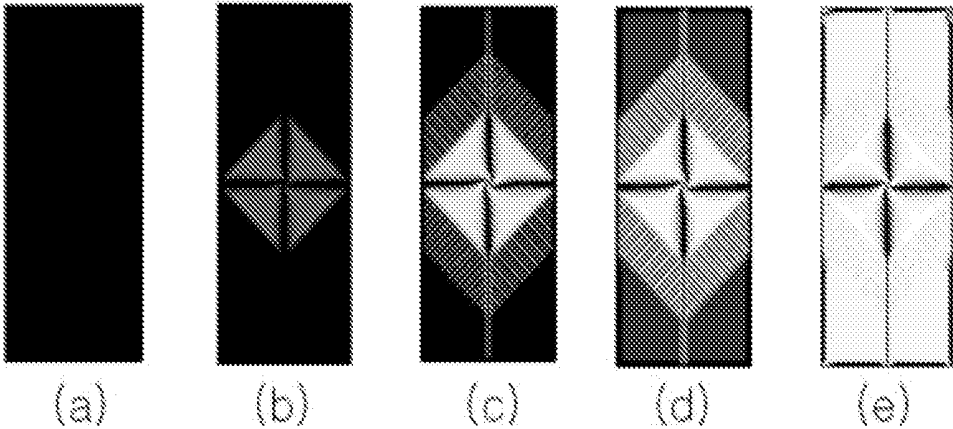

FIG. 25

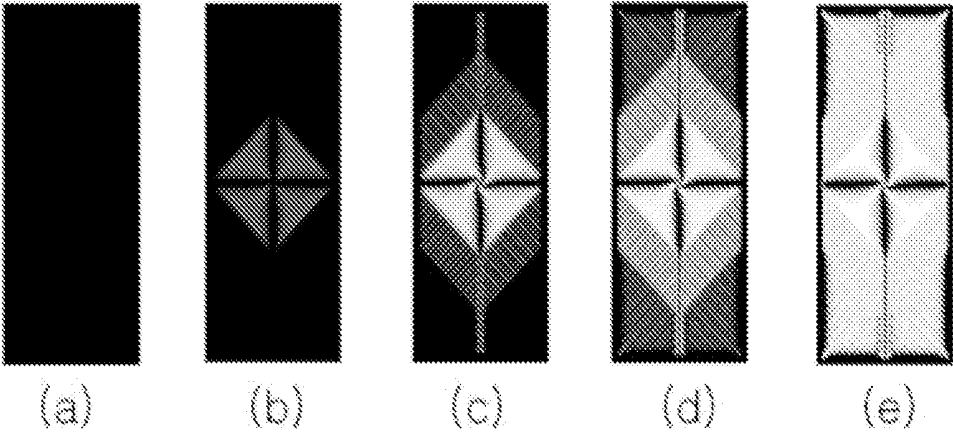
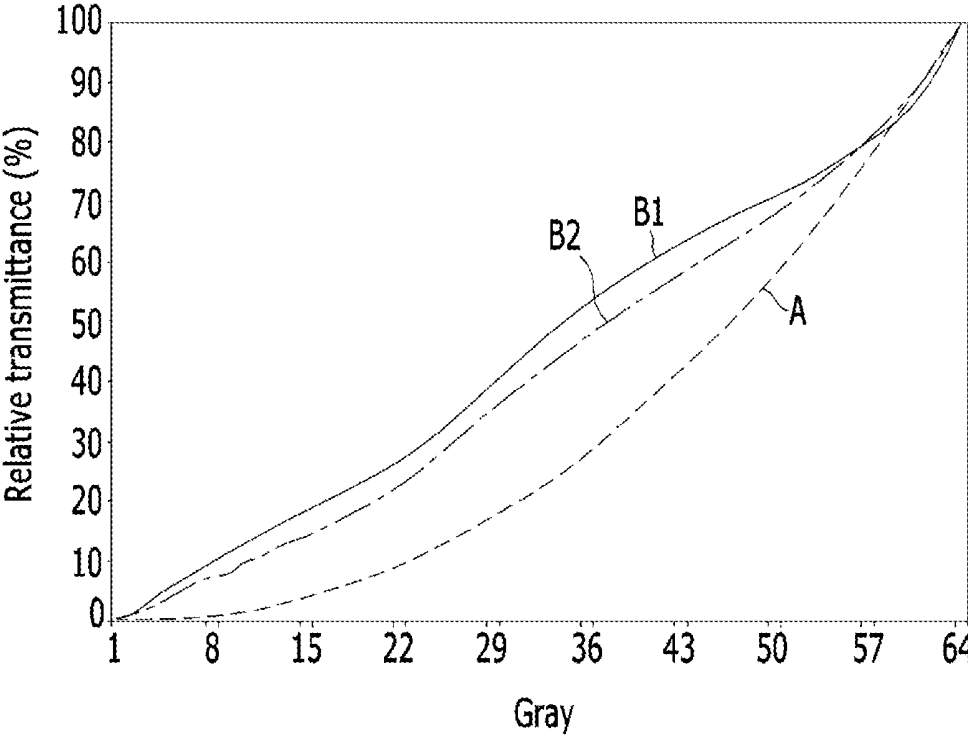

FIG. 26



**LIQUID CRYSTAL DISPLAY HAVING
MULTIPLE PIXEL REGIONS FOR
IMPROVED TRANSMITTANCE**

CROSS-REFERENCE TO RELATED
APPLICATION

[0001] This application claims priority to, and the benefit of, Korean Patent Application No. 10-2013-0010639 filed in the Korean Intellectual Property Office on Jan. 30, 2013, the entire contents of which are incorporated herein by reference.

BACKGROUND OF THE INVENTION

[0002] (a) Technical Field

[0003] Embodiments of the present invention relate generally to flat panel displays. More specifically, embodiments of the present invention relate to liquid crystal displays having multiple pixel regions for improved transmittance.

[0004] (b) Description of the Related Art

[0005] A liquid crystal display, which is one of the most common types of flat panel displays currently in use, includes two panels with field generating electrodes such as a pixel electrode, a common electrode, and the like, with a liquid crystal layer interposed therebetween.

[0006] The liquid crystal display generates an electric field in the liquid crystal layer by applying a voltage to the field generating electrodes, and determines the orientation of liquid crystal molecules of the liquid crystal layer by the generated electric field, thus controlling polarization of incident light so as to display images.

[0007] The LCD also includes switching elements connected to the respective pixel electrodes, and a plurality of signal lines such as gate lines and data lines for controlling the switching elements and applying voltages to the pixel electrodes.

[0008] Different types of LCDs exist. A vertical alignment (VA) mode LCD, which aligns LC molecules such that their long axes are perpendicular to the panels in the absence of an electric field, is sometimes preferred because of its relatively high contrast ratio and wide reference viewing angle. Here, the reference viewing angle implies a viewing angle that has a contrast ratio of 1:10, or a critical angle of gray-to-gray luminance reversion.

[0009] In order to approximate side visibility to front visibility in the vertical alignment mode LCD, a method of causing a difference in transmittance by dividing one pixel into two sub-pixels and applying different voltages to the two sub-pixels has been suggested.

[0010] However, when approximating the side visibility to the front visibility by dividing one pixel into two subpixels and forming different transmittances, the luminance is increased at a low gray or high gray such that gray expression is difficult at the sides, thereby deteriorating display quality.

[0011] Also, when dividing one pixel into two subpixels, the transmittance is decreased according to the interval between the two subpixels.

[0012] The above information disclosed in this Background section is only for enhancement of understanding of the background of the invention and therefore it may contain information that does not form the prior art that is already known in this country to a person of ordinary skill in the art.

SUMMARY

[0013] The present invention provides a liquid crystal display having advantages of expressing more accurate gray in a low gray region and preventing transmittance deterioration while side visibility is close to front visibility.

[0014] A liquid crystal display according to an exemplary embodiment of the present invention includes: a first subpixel electrode positioned on a first substrate and configured to receive a first voltage; a second subpixel electrode positioned on the first substrate and configured to receive a second voltage; and an insulating layer positioned between the first subpixel electrode and the second subpixel electrode, wherein a portion of the first subpixel electrode and a portion of the second subpixel electrode overlap each other with the insulating layer interposed therebetween.

[0015] The liquid crystal display further includes: a second substrate facing the first substrate; and a common electrode positioned on the second substrate, wherein a difference between the first voltage and a common voltage may be larger than a difference between the second voltage and the common voltage.

[0016] At least a portion of the first subpixel electrode may be positioned under the insulating layer, and the second subpixel electrode may be positioned on the insulating layer.

[0017] The first portion of the first subpixel electrode may include a first subregion positioned under the insulating layer and a second subregion positioned on the insulating layer, and the first subregion and the second subregion may be connected to each other through a contact hole formed in the insulating layer.

[0018] The second portion of the second subpixel electrode may include a plurality of branch electrodes extending in a plurality of different directions.

[0019] At least part of the second subpixel electrode besides the portion of the second subpixel electrode may be at least approximately planar.

[0020] The second subpixel electrode may have a cutout formed proximate to at least one of its outer edges.

[0021] The portion of the first subpixel electrode may be a first portion, and the first subpixel electrode may further include a second portion that does not overlap the portion of the second subpixel electrode, and the insulating layer may have a plurality of openings corresponding to the second portion of the first subpixel electrode.

[0022] A liquid crystal display according to another exemplary embodiment of the present invention includes: a first substrate; a first subpixel electrode positioned on the first substrate and configured to receive a first voltage; a second subpixel electrode positioned on the first substrate and configured to receive a second voltage; and an insulating layer positioned between the first subpixel electrode and the second subpixel electrode. One pixel area includes a first region in which a first portion of the first subpixel electrode is positioned, a second region in which a second portion of the first subpixel electrode and a first portion of the second subpixel electrode overlap each other, and a third region in which a second portion of the second subpixel electrode is positioned.

[0023] The second portion of the first subpixel electrode may be positioned under the insulating layer, the first portion of the first subpixel electrode may be positioned on the insulating layer, and the first portion and the second portion may be connected to each other through a contact hole formed in the insulating layer.

[0024] The first portion of the second subpixel electrode may include a plurality of branch electrodes extending in a plurality of different directions.

[0025] At least part of the second portion of the second subpixel electrode may be at least approximately planar.

[0026] The insulating layer may have a plurality of openings corresponding to the first portion of the first subpixel electrode.

[0027] In the liquid crystal display according to an exemplary embodiment of the present invention, a first subpixel electrode and a second subpixel electrode are formed, and a portion of the first subpixel electrode and a portion of the second subpixel electrode overlap each other to divide one pixel area into a first region containing the first subpixel electrode (but not the second subpixel electrode), a second region containing an area of overlap between the first subpixel electrode and the second subpixel electrode, and a third region containing the second subpixel electrode (but not the first subpixel electrode). Accordingly, an accurate gray in a low gray region may be realized along with side visibility that is close to front visibility, and transmittance deterioration that may be generated in the region between the first subpixel electrode and the second subpixel electrode may be reduced or prevented.

BRIEF DESCRIPTION OF THE DRAWINGS

[0028] FIG. 1 is a layout view of the liquid crystal display according to the exemplary embodiment of the present invention.

[0029] FIG. 2 is a cross-sectional view of the liquid crystal display taken along the line II-II of FIG. 1.

[0030] FIG. 3 is a layout view of the first subpixel electrode of the liquid crystal display of FIG. 1.

[0031] FIG. 4 is a layout view of a portion of the first subpixel electrode and the second subpixel electrode of the liquid crystal display of FIG. 1.

[0032] FIG. 5 is a cross-sectional view of the liquid crystal display taken along the line V-V of FIG. 1.

[0033] FIG. 6 is a cross-sectional view of the liquid crystal display taken along the line VI-VI of FIG. 1.

[0034] FIG. 7 is a cross-sectional view of the liquid crystal display taken along the line VII-VII of FIG. 1.

[0035] FIG. 8 is a graph of a transmittance according to a voltage in a liquid crystal display according to an experimental example of the present invention.

[0036] FIG. 9 is a layout view of the liquid crystal display according to another exemplary embodiment of the present invention.

[0037] FIG. 10 is a layout view of the first subpixel electrode of the liquid crystal display of FIG. 9.

[0038] FIG. 11 is a layout view of a portion of the first subpixel electrode and the second subpixel electrode of the liquid crystal display of FIG. 9.

[0039] FIG. 12 is a layout view of the second subpixel electrode of the liquid crystal display of FIG. 9.

[0040] FIG. 13 is a cross-sectional view of the liquid crystal display of FIG. 9 taken along the line XIII-XIII.

[0041] FIG. 14 is a cross-sectional view of the liquid crystal display of FIG. 9 taken along the line XIV-XIV.

[0042] FIG. 15 is a cross-sectional view of the liquid crystal display of FIG. 9 taken along the line XV-XV.

[0043] FIG. 16 is a layout view of the liquid crystal display according to another exemplary embodiment of the present invention.

[0044] FIG. 17 is a layout view of the first subpixel electrode of the liquid crystal display of FIG. 16.

[0045] FIG. 18 is a layout view of a portion of an insulating layer of the liquid crystal display of FIG. 16.

[0046] FIG. 19 is a layout view of the second subpixel electrode of the liquid crystal display of FIG. 16.

[0047] FIG. 20 is a cross-sectional view of the liquid crystal display of FIG. 16 taken along the line XX-XX.

[0048] FIG. 21 is a cross-sectional view of the liquid crystal display of FIG. 16 taken along the line XXI-XXI.

[0049] FIG. 22 is a cross-sectional view of the liquid crystal display of FIG. 16 taken along the line XXII-XXII.

[0050] FIG. 23 to FIG. 25 are electron microscopy pictures showing a brightness change of the liquid crystal display according to an experimental example of the present invention.

[0051] FIG. 26 is a graph of a transmittance change according to a voltage in a liquid crystal display according to another experimental example of the present invention.

DETAILED DESCRIPTION OF THE EMBODIMENTS

[0052] Exemplary embodiments of the present invention will be described in detail with reference to the attached drawings. The present invention may be modified in many different forms, and should not be construed as being limited to the exemplary embodiments set forth herein. Rather, the exemplary embodiments of the present invention are provided so that this disclosure will be thorough and complete, and will fully convey the concept of the present invention to those skilled in the art.

[0053] In the drawings, the thickness of layers and regions may be exaggerated for clarity. In addition, when a layer is described to be formed on another layer or on a substrate, this means that the layer may be formed on the other layer or on the substrate, or a third layer may be interposed between the layer and the other layer or the substrate. Like numbers refer to like elements throughout the specification. The drawings are not necessarily to scale. Any combination and/or permutation of any of the various features of any of the embodiments described herein is contemplated.

[0054] Now, a liquid crystal display according to an exemplary embodiment of the present invention will be described with reference to FIG. 1 to FIG. 7. FIG. 1 is a layout view of the liquid crystal display according to the exemplary embodiment of the present invention. FIG. 2 is a cross-sectional view of the liquid crystal display taken along the line II-II of FIG. 1. FIG. 3 is a layout view of the first subpixel electrode of the liquid crystal display of FIG. 1. FIG. 4 is a layout view of a portion of the first subpixel electrode and the second subpixel electrode of the liquid crystal display of FIG. 1. FIG. 5 is a cross-sectional view of the liquid crystal display taken along the line V-V of FIG. 1. FIG. 6 is a cross-sectional view of the liquid crystal display taken along the line VI-VI of FIG. 1. FIG. 7 is a cross-sectional view of the liquid crystal display taken along the line VII-VII of FIG. 1.

[0055] Firstly, referring to FIG. 1 and FIG. 2, a liquid crystal display according to the present exemplary embodiment includes a lower panel 100 and an upper panel 200 facing each other, and a liquid crystal layer 3 interposed between the two display panels 100 and 200.

[0056] Firstly, the lower panel 100 will be described.

[0057] A gate line 121, a reference voltage line 131, and a storage electrode 135 are formed on an insulation substrate

110 made of transparent glass or plastic. The gate line **121** transfers a gate signal and mainly extends in a transverse direction.

[0058] The gate line **121** includes a first gate electrode **124a**, a second gate electrode **124b**, a third gate electrode **124c**, and a wide end (not shown) for electrical connection with other layers or with an external driving circuit.

[0059] The reference voltage line **131** may extend in parallel to the gate line **121** and may have an expansion **136**, where the expansion **136** is connected to a third drain electrode **175c** that will be described later.

[0060] The reference voltage line **131** includes the storage electrode **135** enclosing a pixel area.

[0061] A gate insulating layer **140** is formed on the gate line **121**, the reference voltage line **131**, and the storage electrode **135**.

[0062] A first semiconductor **154a**, a second semiconductor **154b**, and a third semiconductor **154c** that may be made of amorphous silicon or crystalline silicon, are positioned on the gate insulating layer **140**.

[0063] A plurality of ohmic contacts **163a**, **163b**, **163c**, **165a**, and **165b** are formed on the first semiconductor **154a**, the second semiconductor **154b**, and the third semiconductor **154c**. When the semiconductors **154a**, **154b**, and **154c** are formed with an oxide semiconductor, the ohmic contacts may be omitted.

[0064] Data conductor **171**, **173a**, **173b** **173c**, **175a**, **175b**, and **175c**, including a data line **171** that has a first source electrode **173a** and a second source electrode **173b**, a first drain electrode **175a**, a second drain electrode **175b**, a third source electrode **173c**, and a third drain electrode **175c**, is formed on the ohmic contacts **163a**, **163b**, **163c**, **165a**, and **165b** and the gate insulating layer **140**.

[0065] The second drain electrode **175b** is connected to the third source electrode **173c**.

[0066] The first gate electrode **124a**, the first source electrode **173a**, and the first drain electrode **175a** form a first thin film transistor Qa along with the first semiconductor **154a**, and a channel of this thin film transistor is formed in the semiconductor **154a** between the first source electrode **173a** and the first drain electrode **175a**. Similarly, the second gate electrode **124b**, the second source electrode **173b**, and the second drain electrode **175b** form a second thin film transistor Qb along with the second semiconductor **154b**, and a channel of this thin film transistor is formed in the semiconductor **154b** between the second source electrode **173b** and the second drain electrode **175b**. Likewise, the third gate electrode **124c**, the third source electrode **173c**, and the third drain electrode **175c** form a third thin film transistor Qc along with the third semiconductor Qc, and a channel of this thin film transistor is formed in the semiconductor **154c** between the third source electrode **173c** and the third drain electrode **175c**.

[0067] A first passivation layer **180a**, that may be made of an inorganic insulator such as silicon nitride or silicon oxide, is formed on the data conductors **171**, **173a**, **173b**, **173c**, **175a**, **175b**, and **175c** and exposed portions of the semiconductors **154a**, **154b**, and **154c**.

[0068] A color filter **230** is positioned on the first passivation layer **180a**.

[0069] A light blocking member (not shown) is positioned on a region where the color filter **230** is not positioned, as well as on a portion of the color filter **230**. The light blocking member is referred to as a black matrix and prevents light leakage.

[0070] An overcoat (capping layer) **80** is positioned on the color filter **230**. The overcoat **80** prevents peeling of the color filter **230** and the light blocking member, and suppresses contamination of the liquid crystal layer **3** by an organic material of the solvent that inflows from the color filter **230**, so that it prevents defects such as afterimages that may occur when an image is driven.

[0071] A first subregion **191a1** of a first subpixel electrode **191a** is formed on the overcoat **80**.

[0072] Referring to FIG. 3, the first subregion **191a1** of the first subpixel electrode **191a** has a plane shape (i.e. is at least approximately planar) positioned at the center of the pixel area, and includes a cross-shaped connection and four parallelograms positioned near the cross-shaped connection and enclosing, or surrounding, the cross-shaped connection. In FIG. 3, the four parallelograms form the two chevron-shaped structures directly above and below the cross-shaped connection. A first expansion **193** is positioned at a center portion of the cross-shaped connection. Also, a protrusion extending upward and downward from a transverse center portion of the pixel area is provided. The first subregion **191a1** of the first subpixel electrode **191a** is positioned over a portion of the pixel area.

[0073] A second passivation layer **180b** is formed on the overcoat **80** and the first subregion **191a1** of the first subpixel electrode **191a**.

[0074] A second subregion **191a2** of the first subpixel electrode **191a**, and the second subpixel electrode **191b**, are formed on the second passivation layer **180b**.

[0075] Referring to FIG. 4, the second subregion **191a2** of the first subpixel electrode **191a** is positioned at the center portion of the pixel, and generally outlines a rhombus shape. The second subregion **191a2** of the first subpixel electrode **191a** includes a cross-shaped stem having a transverse portion and a longitudinal portion, and a plurality of first branch electrodes extending from the cross-shaped stem. The first branch electrodes extend in four directions.

[0076] The second subpixel electrode **191b** includes a third subregion overlapping the first subregion **191a1** of the first subpixel electrode **191a**, and a fourth subregion. The third subregion of the second subpixel electrode **191b** overlaps the first subregion **191a1** of the first subpixel electrode **191a** via an insulating layer (i.e. the second passivation layer **180b**), and includes a plurality of second branch electrodes extending in the same directions as those of a plurality of the first branch electrodes of the second subregion **191a2** of the first subpixel electrode **191a**.

[0077] The fourth subregion of the second subpixel electrode **191b** includes a planar plate portion with a trapezoid shape, and a plurality of the third branch electrodes positioned outside the plate portion and extending in a direction parallel to the plurality of the second branch electrodes. The plate shape is a plate shape as it is without splitting.

[0078] The first passivation layer **180a** and the overcoat **80** have a first contact hole **185a** exposing a portion of the first drain electrode **175a**, and the first passivation layer **180a**, the overcoat **80**, and the second passivation layer **180b** have a second contact hole **185b** exposing a portion of the second drain electrode **175b**. Also, the second passivation layer **180b** has a third contact hole **186** exposing a center portion of the first subregion **191a1** of the first subpixel electrode **191a**. The first passivation layer **180a** and the overcoat **80** have a fourth

contact hole **185c** exposing the expansion **136** of the reference voltage line **131** and a portion of the third drain electrode **175c**.

[0079] The first subregion **191a1** of the first subpixel electrode **191a** is physically and electrically connected to the first drain electrode **175a** through the first contact hole **185a**, and the second subpixel electrode **191b** is physically and electrically connected to the second drain electrode **175b** through the second contact hole **185b**. Also, the second subregion **191a2** of the first subpixel electrode **191a** is connected to the first expansion **193** of the first subregion **191a1** of the first subpixel electrode **191a** through the third contact hole **186** formed in the second passivation layer **180b**. The expansion **136** of the reference voltage line **131** is connected to a portion of the third drain electrode **175c** by a connecting member **195** disposed on the fourth contact hole **185c**. The connecting member **195** may be formed with the same layer as the second subpixel electrode **191**.

[0080] The first subpixel electrode **191a** and the second subpixel electrode **191b** receive the data voltage from the first drain electrode **175a** and the second drain electrode **175b**, through the first contact hole **185a** and the second contact hole **185b** respectively.

[0081] Now, the upper panel **200** will be described.

[0082] A light blocking member **220** and a common electrode **270** are formed on an insulation substrate **210** made of transparent glass or plastic.

[0083] However, in the case of a liquid crystal display according to another exemplary embodiment of the present invention, the light blocking member **220** may instead be positioned on the lower panel **100**, and in the case of a liquid crystal display according to another exemplary embodiment of the present invention, the color filter may instead be positioned on the upper panel **200**.

[0084] Alignment layers (not shown) may be formed on an inner surface of the display panels **100** and **200**, and they may be vertical alignment layers.

[0085] A polarizer (not shown) may be provided on the outer surface of each of the two display panels **100** and **200**, and it is preferable that transmissive axes of the two polarizers may be orthogonal to each other and that any one transmissive axis is parallel to the gate line **121**. However, the polarizer may alternatively be disposed only at one outer surface of the two display panels **100** and **200**.

[0086] The liquid crystal layer **3** has negative dielectric anisotropy, and liquid crystal molecules of the liquid crystal layer **3** may be aligned so that long axes thereof are perpendicular with respect to the surface of the two display panels **100** and **200** when no electric field is applied. Therefore, the incident light does not pass through the crossed polarizers but is blocked when there is no applied electric field.

[0087] At least one of the liquid crystal layer **3** and the alignment layer may include a photoreactive material, in detail, a reactive mesogen.

[0088] Next, a driving method of a liquid crystal display according to the present exemplary embodiment will be described.

[0089] If a gate-on signal is applied to the gate line **121**, the first gate electrode **124a**, the second gate electrode **124b**, and the third gate electrode **124c** receive the gate-on signal such that the first switching element **Qa**, the second switching element **Qb**, and the third switching element **Qc** are each turned on. Accordingly, the data voltage applied to the data line **171** is applied to the first subpixel electrode **191a** and the

second subpixel electrode **191b** through the turned-on first switching element **Qa** and second switching element **Qb**. The voltage applied to the second subpixel electrode **191b** is divided through the third switching element **Qc** connected in series to the second switching element **Qb**. Accordingly, the voltage applied to the second subpixel electrode **191b** is lower than the voltage applied to the first subpixel electrode **191a**.

[0090] Again, referring to FIG. 1, one pixel area of the liquid crystal display according to the present exemplary embodiment includes a first region **R1** where the second subregion **191a2** of the first subpixel electrode **191a** is positioned, a second region **R2** where a portion of the first subregion **191a1** of the first subpixel electrode **191a** and a portion of the second subpixel electrode **191b** overlap each other, and a third region **R3** where a portion of the second subpixel electrode **191b** is positioned.

[0091] The first region **R1**, the second region **R2**, and the third region **R3** respectively include four subregions. In four subregions, the liquid crystal molecules are aligned in different directions.

[0092] An area of the second region **R2** may be about two times the area of the first region **R1**, and the area of the third region **R3** may be about two times the area of the second region **R2**.

[0093] Next, the first region **R1**, the second region **R2**, and the third region **R3** included in one pixel area of a liquid crystal display according to the present exemplary embodiment will be described with reference to FIG. 5 to FIG. 7.

[0094] Referring to FIG. 5, in the first region **R1** of one pixel area of the liquid crystal display according to the present exemplary embodiment, the second subregion **191a2** of the first subpixel electrode **191a** and the common electrode **270** generate the electric field. As above, the second subregion **191a2** of the first subpixel electrode **191a** includes a cross-shaped stem and a plurality of first branch electrodes extending in four different directions. The plurality of first branch electrodes may be inclined with an angle of about 40 degrees to about 45 degrees with respect to the gate line **121**. When a fringe field is generated at the edge of the plurality of first branch electrodes, the liquid crystal molecules of the liquid crystal layer **3** positioned at the first region **R1** are inclined in four different directions. In detail, the horizontal component of the fringe field generated by the plurality of first branch electrodes is parallel to the edge of the plurality of first branch electrodes, such that the liquid crystal molecules are oriented in the length direction parallel to the plurality of first branch electrodes.

[0095] Referring to FIG. 6, in the second region **R2** of one pixel area of the liquid crystal display according to the present exemplary embodiment, the third subregion of the second subpixel electrode **191b** and the first subregion **191a1** of the first subpixel electrode **191a** overlap each other. Accordingly, the liquid crystal molecules of the liquid crystal layer **3** are arranged according to the electric field formed between the third subregion of the second subpixel electrode **191b** and the common electrode **270**, the electric field formed between the part of the first subregion **191a1** that is exposed between the plurality of second branch electrodes of the third subregion of the second subpixel electrode **191b** and the common electrode **270**, and the electric field formed between the third subregion of the second subpixel electrode **191b** and the first subregion **191a1** of the first subpixel electrode **191a**.

[0096] Next, referring to FIG. 7, in the third region **R3** of one pixel area of the liquid crystal display according to the

present exemplary embodiment, the fourth subregion of the second subpixel electrode **191b** and the common electrode **270** together generate the electric field. At this time, a portion of the fourth subregion of the second subpixel electrode **191b** has a plate shape and the remaining portion has a plurality of third branch electrodes. Thus, through the plate shape of the second subpixel electrode **191b**, the transmittance of the liquid crystal display may be increased. The liquid crystal molecules positioned corresponding to the portion of the second subpixel electrode **191b** having the plate shape are inclined by the fringe field formed by the plurality of second branch electrodes and the plurality of third branch electrodes in different directions, such that the liquid crystal molecules are slanted in the length direction of the plurality of second branch electrodes and the plurality of third branch electrodes.

[0097] As described above, the magnitude of the second voltage applied to the second subpixel electrode **191b** is smaller than the magnitude of the first voltage applied to the first subpixel electrode **191a**.

[0098] Accordingly, the intensity of the electric field applied to the liquid crystal layer positioned at the first region **R1** is largest and the intensity of the electric field applied to the liquid crystal layer positioned at the third region **R3** is smallest. The second region **R2** is influenced by the electric field of the first subpixel electrode **191a** positioned under the second subpixel electrode **191b**, such that the intensity of the electric field applied to the liquid crystal layer positioned at the second region **R2** is smaller than the intensity of the electric field applied to the liquid crystal layer positioned at the first region **R1**, and is larger than the intensity of the electric field applied to the liquid crystal layer positioned at the third region **R3**.

[0099] As described above, one pixel area of the liquid crystal display according to an exemplary embodiment of the present invention is divided into a first region where a first subpixel electrode has a relatively high first voltage, a second region where the portion of the first subpixel electrode with the relatively high first voltage and a portion of the second subpixel electrode having a relatively low second voltage overlap each other via an insulating layer interposed therebetween, and a third region where the second subpixel electrode with the relatively low second voltage is positioned. Accordingly, the intensities of the electric field applied to the liquid crystal molecules corresponding to the first region, the second region, and the third region are different such that the inclination angles of the liquid crystal molecules are different, thereby realizing a different luminance for each region. By dividing one pixel area into three regions of differing luminances, the change in transmittance according to gray shade may be made smoother, thereby preventing a sharp change of transmittance due to a gray change from a low gray to a high gray at the side, while making the lateral visibility approximately the same as the front visibility. Accordingly, gray expression in low gray and high gray is improved.

[0100] Next, a liquid crystal display according to one experimental example of the present invention will be described with reference to FIG. 8. FIG. 8 is a graph of a transmittance according to a voltage in a liquid crystal display according to experiment carried out on embodiments of the present invention.

[0101] In the present experimental example, like the liquid crystal display according to an exemplary embodiment of the present invention, for a case that the intensity of the voltage applied to the second subpixel electrode **191b** is smaller than

the voltage applied to the first subpixel electrode **191a** and a case that the intensity of the voltage applied to the second subpixel electrode **191b** is larger than the voltage applied to the first subpixel electrode **191a**, a transmittance(H) according to the voltage of the first region **R1**, a transmittance(L) according to the voltage of the third region **R3**, and transmittance(C1 and C2) according to the voltage of the second region **R2** are measured and are shown as a graph.

[0102] Referring to FIG. 8, like the liquid crystal display according to an exemplary embodiment of the present invention, in the case in which the intensity of the voltage applied to the second subpixel electrode **191b** is smaller than the voltage applied to the first subpixel electrode **191a**, the curve of the transmittance C1 according to the voltage of the second region **R2** is positioned between the curve of the transmittance H according to the voltage of the first region **R1** and the curve of the transmittance L according to the voltage of the third region **R3**. However, in the case C2 in which the intensity of the voltage applied to the second subpixel electrode **191b** is larger than the intensity of the voltage applied to the first subpixel electrode **191a**, referring to the curve of the transmittance C2 according to the voltage of the second region **R2**, the transmittance value for the voltage of the second region **R2** is slightly larger than the transmittance value according to the voltage of the first region **R1**, and the difference is small.

[0103] Like the liquid crystal display according to an exemplary embodiment of the present invention, the portion of the first subpixel electrode **191a** with a relatively high applied voltage is disposed under the second region **R2** and the portion of the second subpixel electrode **191b** with a relatively low applied voltage is disposed on the second region **R2**. Thus, it may be confirmed that three regions having different transmittance may exist for the same applied voltage, and the transmittance change of the three regions may be sequentially generated. That is, in the case of the liquid crystal display according to an exemplary embodiment of the present invention, one pixel area is divided into three regions having different luminance that are sequentially changed.

[0104] Also, at least two of the first region, the second region, and the third region at least partially overlap each other. In particular, a portion of the first subpixel electrode having the first applied voltage and the portion of the second subpixel electrode having the second applied voltage are overlapped such that the transmittance deterioration generated in the region between the first subpixel electrode and the second subpixel electrode may be prevented, thereby increasing the overall transmittance.

[0105] Next, a liquid crystal display according to another exemplary embodiment of the present invention will be described with reference to FIG. 9 to FIG. 15. FIG. 9 is a layout view of the liquid crystal display according to another exemplary embodiment of the present invention. FIG. 10 is a layout view of the first subpixel electrode of the liquid crystal display of FIG. 9. FIG. 11 is a layout view of a portion of the first subpixel electrode and the second subpixel electrode of the liquid crystal display of FIG. 9. FIG. 12 is a layout view of the second subpixel electrode of the liquid crystal display of FIG. 9. FIG. 13 is a cross-sectional view of the liquid crystal display of FIG. 9 taken along the line XIII-XIII. FIG. 14 is a cross-sectional view of the liquid crystal display of FIG. 9 taken along the line XIV-XIV. FIG. 15 is a cross-sectional view of the liquid crystal display of FIG. 9 taken along the line XV-XV.

[0106] Referring to FIG. 9 to FIG. 15, the liquid crystal display according to the present exemplary embodiment is similar to the liquid crystal display according to the exemplary embodiment described with reference to FIG. 1 to FIG. 7. Detailed description of the same reference numerals is omitted for brevity and clarity.

[0107] In the liquid crystal display according to the present exemplary embodiment, like the liquid crystal display according to the exemplary embodiment described with reference to FIG. 1 to FIG. 7, one pixel area is divided into a first region R1 where the first subpixel electrode that receives a relatively high first voltage is positioned, a second region R2 where the portion of the first subpixel electrode and the portion of the second subpixel electrode each receive a relatively low second voltage and overlap each other via the insulating layer interposed therebetween, as well as a third region R3 where the second subpixel electrode receives a relatively low second voltage. The area of the second region R2 may be about two times the area of the first region R1, and the area of the third region R3 may be about two times the area of the second region R2.

[0108] Referring to FIG. 9 and FIG. 10, in the liquid crystal display according to the present exemplary embodiment, differently from the liquid crystal display according to the exemplary embodiment described with reference to FIG. 1 to FIG. 7, the first subpixel electrode 191a is not divided into the first subregion 191a1 and the second subregion 191a2. Also, the first subpixel electrode 191a has a plate or flat, planar shape mainly positioned at the center portion of the pixel.

[0109] Also, referring to FIG. 11 along with FIG. 9, the second passivation layer 180b is an insulating layer positioned between the first subpixel electrode 191a, and the second subpixel electrode 191b has a plurality of openings 83. The plurality of openings 83 has a grouped shape in which four right triangles are positioned at the center and are gathered together so that their shorter sides all face inward toward each other, thereby collectively creating an outer shape similar to a rhombus.

[0110] Referring to FIG. 13, in the first region R1 of the liquid crystal display according to the present exemplary embodiment, the first subpixel electrode 191a positioned at the lower panel 100 and having a relatively high first applied voltage, together with the common electrode 270 positioned at the upper panel 200, act to generate the electric field. At this time, the liquid crystal molecules are inclined in four different directions by the openings 83 formed in the second passivation layer 180b. In detail, referring to FIG. 9, FIG. 10, FIG. 11, and FIG. 13, because of the plurality of openings 83 formed in the second passivation layer 180b, liquid crystal molecules 31 positioned on the first subpixel electrode 191a are inclined in directions perpendicular to the edges of the openings 83.

[0111] Referring to FIG. 12 along with FIG. 9, the third subregion of the second subpixel electrode 191b, which overlaps the first subpixel electrode 191a, includes a plurality of second branch electrodes 194a extending in four directions. However, a fourth subregion 194b of the second subpixel electrode 191b that does not overlap the first subpixel electrode 191a has a flat, plate-type shape and has a cutout 92 formed along its outer edge, and along the edge of the pixel area. The liquid crystal molecules positioned near the fourth subregion 194b are influenced by the liquid crystal molecules positioned corresponding to the third subregion of the second subpixel electrode 191b, and are thus inclined in directions

parallel to the length directions of the second branch electrodes 194a. In other words, liquid crystal molecules in this area are influenced by the fringe field formed by the outer edge of the second subpixel electrode 191b, thereby being inclined in directions parallel to the length directions of the second branch electrodes.

[0112] At this time, the cutout 92 formed along with the edge of the second subpixel electrode 191b reduces the influence of the fringe field formed at the edge of the second subpixel electrode 191b, so that the liquid crystal molecules positioned at the edge of the pixel area are prevented from being inclined in directions vertical to the edge of the pixel area. Thereby, the liquid crystal molecules positioned at the edge of the pixel area are inclined in directions parallel to the length direction of the second branch electrodes. Accordingly, transmittance reduction may be prevented or ameliorated.

[0113] Referring to FIG. 14, in the second region R2 of one pixel area of a liquid crystal display according to the present exemplary embodiment, the third subregion of the second subpixel electrode 191b overlaps a portion of the first subpixel electrode 191a. Accordingly, the liquid crystal molecules of the liquid crystal layer 3 are arranged according to the influence of each of (1) the electric field formed between the third subregion of the second subpixel electrode 191b and the common electrode 270, (2) the electric field formed between the common electrode 270 and the first subpixel electrode 191a positioned between the plurality of second branch electrodes of the third subregion of the second subpixel electrode 191b, and (3) the electric field formed between the third subregion of the second subpixel electrode 191b and the first subpixel electrode 191a.

[0114] Next, referring to FIG. 15, in the third region R3 of one pixel area of a liquid crystal display according to the present exemplary embodiment, the second subpixel electrode 191b positioned at the lower panel 100 and the common electrode 270 positioned at the upper panel 200 together generate the electric field.

[0115] As described above, one pixel area of a liquid crystal display according to an exemplary embodiment of the present invention is divided into a first region where the first subpixel electrode is present but not the second subpixel electrode and the first subpixel electrode is to have a relatively high first voltage applied, a second region where a portion of the first subpixel electrode and a portion of the second subpixel electrode overlap each other and are to have a relatively low second voltage applied, and a third region where the second subpixel electrode is present but not the first subpixel electrode and the second subpixel electrode is to have a relatively low second voltage applied. Accordingly, the intensities of the electric field applied to the liquid crystal molecules corresponding to the first region, the second region, and the third region are different, such that the inclination angles of the liquid crystal molecules are different, thereby realizing a different luminance for each region. In this manner, by dividing one pixel area into three regions of differing luminances, the change in transmittance according to gray value may be made smoother. By preventing sharp change in transmittance according to gray change in the low gray and the high gray at the side, while approximating the lateral visibility to the front visibility, the gray expression in the low gray and the high gray is improved.

[0116] Also, the first region, the second region, and the third region of one pixel area are not separated from each

other, and the portion of the first subpixel electrode applied with the first voltage and the portion of the second subpixel electrode applied with the second voltage are overlapped such that transmittance deterioration generated in the region between the first subpixel electrode and the second subpixel electrode may be prevented, thereby increasing the overall transmittance. Many characteristics of the liquid crystal display according to the exemplary embodiment described with reference to FIG. 1 to FIG. 7 may be applied to the liquid crystal display according to the present exemplary embodiment.

[0117] Next, a liquid crystal display according to another exemplary embodiment of the present invention will be described with reference to FIG. 16 to FIG. 22. FIG. 16 is a layout view of the liquid crystal display according to another exemplary embodiment of the present invention. FIG. 17 is a layout view of the first subpixel electrode of the liquid crystal display of FIG. 16. FIG. 18 is a layout view of a portion of an insulating layer of the liquid crystal display of FIG. 16. FIG. 19 is a layout view of the second subpixel electrode of the liquid crystal display of FIG. 16. FIG. 20 is a cross-sectional view of the liquid crystal display of FIG. 16 taken along the line XX-XX. FIG. 21 is a cross-sectional view of the liquid crystal display of FIG. 16 taken along the line XXI-XXI. FIG. 22 is a cross-sectional view of the liquid crystal display of FIG. 16 taken along the line XXII-XXII.

[0118] Referring to FIG. 16 to FIG. 22, a liquid crystal display according to the present exemplary embodiment is similar to the liquid crystal display according to the exemplary embodiment described with reference to FIG. 1 to FIG. 7 and the liquid crystal display according to the exemplary embodiment described with reference to FIG. 9 to FIG. 15. The detailed description for identical reference numerals is thus omitted.

[0119] In the liquid crystal display according to the present exemplary embodiment, like the liquid crystal display according to the exemplary embodiment described with reference to FIG. 1 to FIG. 7, one pixel area is divided into a first region R1 where the first subpixel electrode receives a relatively high first voltage, the second region R2 where a portion of the first subpixel electrode and an overlapping portion of the second subpixel electrode receive a relatively low second voltage, and the third region R3 where the second subpixel electrode also receives the relatively low second voltage. The area of the second region R2 may be about two times the area of the first region R1, and the area of the third region R3 may be about two times the area of the second region R2.

[0120] Referring to FIG. 16 and FIG. 17, in a liquid crystal display according to the present exemplary embodiment, differently from the liquid crystal display according to the exemplary embodiment described with reference to FIG. 1 to FIG. 7, the first subpixel electrode 191a is not divided into a first subregion 191a1 and a second subregion 191a2, and the first subpixel electrode 191a has a shape when viewed in plan view, where this shape is mainly positioned at the center portion of the pixel.

[0121] Referring to FIG. 18 along with FIG. 16, in a liquid crystal display according to the present exemplary embodiment, like the exemplary embodiment shown in FIG. 9 to FIG. 15, the second passivation layer 180b is an insulating layer positioned between the first subpixel electrode 191a and the second subpixel electrode 191b, and has a plurality of openings 83. The plurality of openings 83 have a grouped shape in which four right triangles are positioned at the center

and are gathered together with their shorter sides facing each other, so that their collective outer shape is similar to a rhombus.

[0122] Referring to FIG. 19 along with FIG. 16, the second subpixel electrode 191b of the liquid crystal display according to the present exemplary embodiment has a plurality of fourth branch electrodes 194c in the region overlapping the first subpixel electrode 191a, as well as extending to the outer edges of electrode 191b. Accordingly, in addition to the second region R2 where the first subpixel electrode 191a and the second subpixel electrode 191b overlap, the liquid crystal molecules positioned at the third region R3 where only the second subpixel electrode 191b is positioned are all inclined parallel to the length direction of the fourth branch electrode by the influence of the fringe field formed by the fourth branch electrodes.

[0123] Referring to FIG. 20, in the first region R1 of a liquid crystal display according to the present exemplary embodiment, the first subpixel electrode 191a and the common electrode 270 collectively generate an electric field. At this time, the liquid crystal molecules are inclined in four different directions by the openings 83 formed in the second passivation layer 180b. In detail, referring to FIG. 15, FIG. 16, FIG. 17, and FIG. 19, the liquid crystal molecules 31 positioned on the first subpixel electrode 191a are inclined perpendicular to the edge of the openings 83, and thereby the inclination directions of the liquid crystal molecules 31 are different in the different regions of the pixel.

[0124] Referring to FIG. 21, in the second region R2 of one pixel area of a liquid crystal display according to the present exemplary embodiment, the illustrated portion of the second subpixel electrode 191b overlaps the shown portion of the first subpixel electrode 191a. Accordingly, nearby liquid crystal molecules of the liquid crystal layer 3 are oriented by the electric field formed between the second subpixel electrode 191b and the common electrode 270, the electric field formed between the first subpixel electrode 191a positioned between the plurality of fourth branch electrodes of the second subpixel electrode 191b and the common electrode 270, and the electric field formed between the plurality of fourth branch electrodes of the second subpixel electrode 191b and the first subpixel electrode 191a.

[0125] Referring to FIG. 22, in the third region R3 of one pixel area of a liquid crystal display according to the present exemplary embodiment, the second subpixel electrode 191b positioned at the lower panel 100 and the common electrode 270 positioned at the upper panel 200 together generate the electric field.

[0126] As described above, one pixel area of a liquid crystal display according to an exemplary embodiment of the present invention is divided into a first region where the first subpixel electrode is present and receives a relatively high first voltage, a second region where a portion of the first subpixel electrode overlaps portion of the second subpixel electrode and each receives a relatively low second voltage, and a third region where the second subpixel electrode is present and receives the relatively low second voltage. Accordingly, the intensities of the electric field applied to the liquid crystal molecules corresponding to the first region, the second region, and the third region are different, so that the inclination angles of the liquid crystal molecules are different, thereby creating a different luminance for each region. Thus, by dividing one pixel area into three regions having different luminances, the change in transmittance according to gray value may be made

smoother. By preventing sharp change in transmittance according to gray change in the low gray and the high gray at the side, while approximating the lateral visibility to the front visibility, the gray expression in the low gray and the high gray is improved.

[0127] Also, the first region, the second region, and the third region of one pixel area are not separated from each other, and the portion of the first subpixel electrode applied with the first voltage overlaps the portion of the second subpixel electrode applied with the second voltage, such that the transmittance deterioration generated in the region between the first subpixel electrode and the second subpixel electrode may be prevented, thereby increasing the overall pixel transmittance.

[0128] Many characteristics of a liquid crystal display according to the exemplary embodiment described with reference to FIG. 1 to FIG. 7 and a liquid crystal display according to the exemplary embodiment described with reference to FIG. 9 to FIG. 15 may be applied to a liquid crystal display according to the present exemplary embodiment.

[0129] Next, a brightness change of the liquid crystal display according to an experimental example of the present invention will be described with reference to FIG. 23 to FIG. 25. FIG. 23 to FIG. 25 are electron microscopy pictures showing a brightness change of the liquid crystal display according to an experimental display constructed according to embodiments of the present invention.

[0130] In the present experimental example, after forming a liquid crystal display according to the exemplary embodiment shown in FIG. 1, FIG. 9, and FIG. 16, while changing the intensity of the electric field applied to the liquid crystal layer, the brightness of one pixel was measured by electron microscopy.

[0131] FIG. 23 shows a result for a liquid crystal display constructed according to the exemplary embodiment shown in FIG. 1, FIG. 24 shows a result for a liquid crystal display constructed according to the exemplary embodiment shown in FIG. 9, and FIG. 25 shows a result for a liquid crystal display constructed according to the exemplary embodiment shown in FIG. 16.

[0132] Referring to FIG. 23 to FIG. 25, for a liquid crystal display according to an exemplary embodiment of the present invention, as the intensity of the electric field applied to the liquid crystal layer is increased, the brightness is increased in the first, second, and third regions sequentially. Also, the transmittance change of the first region, the second region, the third region is readily seen.

[0133] In this manner, by forming different subregions having three different transmittances, the lateral visibility may be controlled to be close to the front visibility.

[0134] Next, a transmittance change according to a voltage for a liquid crystal display according to another experimental example of the present invention will be described with reference to FIG. 26. FIG. 26 is a graph of transmittance change according to a voltage in a liquid crystal display according to another experimental example of the present invention.

[0135] In the present experimental example, for a first case in which one pixel area is divided into a region occupied by a first subpixel electrode and a region occupied by a second subpixel electrode as in conventional liquid crystal displays, and a second case in which one pixel area is divided into three regions as in the embodiments described above, a transmittance change A according to gray seen in the front of the liquid crystal display and transmittance changes B1 and B2

according to gray seen at a side of the liquid crystal display are compared. In FIG. 26, the transmittance change according to gray seen at the side of the liquid crystal display for the first case is indicated by B1, and the transmittance change according to gray at the side of the liquid crystal display for the second case is indicated by B2.

[0136] Referring to FIG. 26, the curve B2 is closer to curve A than is curve B1. That is, the transmittance at the sides of the three-region pixel areas of embodiments of the invention more closely resembles the transmittance at the front of a display than does the transmittance at the sides of conventional two-region pixel areas. Particularly, the three-region display can be seen to exhibit a more smoothly increasing transmittance than the two-region display, with a more gradual increase in transmittance at both low and high gray values. Thus, in liquid crystal displays according to an exemplary embodiment of the present invention, the transmittance change as a function of gray value is made smoother, such that more correct gray expression is possible. Accordingly, a liquid crystal display according to an exemplary embodiment of the present invention may prevent or reduce the deterioration of the display quality at higher viewing angles and/or high and low gray values.

[0137] While this invention has been described in connection with what is presently considered to be practical exemplary embodiments, it is to be understood that the invention is not limited to the disclosed embodiments, but, on the contrary, is intended to cover various modifications and equivalent arrangements included within the spirit and scope of the appended claims.

What is claimed is:

1. A liquid crystal display comprising:

a first substrate;
a first subpixel electrode positioned on the first substrate and configured to receive a first voltage;
a second subpixel electrode positioned on the first substrate and configured to receive a second voltage;
an insulating layer positioned between the first subpixel electrode and the second subpixel electrode;
a second substrate facing the first substrate; and
a common electrode positioned on the second substrate, wherein a portion of the first subpixel electrode and a portion of the second subpixel electrode overlap each other with the insulating layer interposed therebetween, and

wherein a difference between the first voltage and a common voltage is larger than a difference between the second voltage and the common voltage.

2. The liquid crystal display of claim 1, wherein at least a portion of the first subpixel electrode is positioned under the insulating layer, and the second subpixel electrode is positioned on the insulating layer.

3. The liquid crystal display of claim 2, wherein the portion of the first subpixel electrode includes a first subregion positioned under the insulating layer and a second subregion positioned on the insulating layer, and the first subregion and the second subregion are connected to each other through a contact hole formed in the insulating layer.

4. The liquid crystal display of claim 3, wherein the portion of the second subpixel electrode includes a plurality of branch electrodes extending in a plurality of different directions.

5. The liquid crystal display of claim 4, wherein at least part of the second subpixel electrode besides the portion of the second subpixel electrode is at least approximately planar.
6. The liquid crystal display of claim 5, wherein the second subpixel electrode has a cutout formed proximate to at least one of its outer edges.
7. The liquid crystal display of claim 2, wherein the portion of the first subpixel electrode is a first portion, and the first subpixel electrode further includes a second portion that does not overlap the portion of the second subpixel electrode, and the insulating layer has a plurality of openings corresponding to the second portion of the first subpixel electrode.
8. The liquid crystal display of claim 7, wherein the portion of the second subpixel electrode includes a plurality of branch electrodes extending in a plurality of different directions.
9. The liquid crystal display of claim 8, wherein at least part of the second subpixel electrode besides the portion of the second subpixel electrode is at least approximately planar.
10. The liquid crystal display of claim 9, wherein the second subpixel electrode has a cutout formed proximate to at least one of its outer edges.
11. The liquid crystal display of claim 10, wherein the first subpixel electrode further includes a third portion that does not overlap the portion of the second subpixel electrode, an area of overlap between the first portion of the first subpixel electrode and the portion of the second subpixel electrode is about two times an area of the second portion of the first subpixel electrode, and an area of the third portion of the first subpixel electrode is about two times the area of overlap.
12. The liquid crystal display of claim 1, wherein the second portion of the second subpixel electrode includes a plurality of branch electrodes extending in a plurality of different directions.
13. The liquid crystal display of claim 12, wherein at least part of the second subpixel electrode besides the portion of the second subpixel electrode is at least approximately planar.
14. The liquid crystal display of claim 13, wherein the second subpixel electrode has a cutout formed proximate to at least one of its outer edges.
15. The liquid crystal display of claim 1, wherein the first subpixel electrode further includes a second portion that does not overlap the portion of the second subpixel electrode, the portion of the second subpixel electrode is a first portion, and the second subpixel electrode further includes a second portion that does not overlap the first portion of the first subpixel electrode, an area of overlap between the first portion of the first subpixel electrode and the first portion of the second subpixel electrode is about two times an area of the second portion of the first subpixel electrode, and the area of the second portion of the second subpixel electrode is substantially about two times the area of overlap.
16. A liquid crystal display comprising:
a first substrate;
a first subpixel electrode positioned on the first substrate and configured to receive a first voltage;
- a second subpixel electrode positioned on the first substrate and configured to receive a second voltage; and
an insulating layer positioned between the first subpixel electrode and the second subpixel electrode,
wherein one pixel area includes a first region in which a first portion of the first subpixel electrode is positioned, a second region in which a second portion of the first subpixel electrode and a first portion of the second subpixel electrode overlap each other, and a third region in which a second portion of the second subpixel electrode is positioned.
17. The liquid crystal display of claim 16, further comprising:
a second substrate facing the first substrate; and
a common electrode positioned on the second substrate, wherein a difference between the first voltage and a common voltage is larger than a difference between the second voltage and the common voltage.
18. The liquid crystal display of claim 17, wherein at least a portion of the first subpixel electrode is positioned under the insulating layer, and the second subpixel electrode is positioned on the insulating layer.
19. The liquid crystal display of claim 18, wherein an area of the second region is about two times an area of the first region, and an area of the third region is about two times the area of the second region.
20. The liquid crystal display of claim 18, wherein the second portion of the first subpixel electrode is positioned under the insulating layer, the first portion of the first subpixel electrode is positioned on the insulating layer, and the first portion and the second portion are connected to each other through a contact hole formed in the insulating layer.
21. The liquid crystal display of claim 20, wherein the first portion of the second subpixel electrode includes a plurality of branch electrodes extending in a plurality of different directions.
22. The liquid crystal display of claim 21, wherein at least part of the second portion of the second subpixel electrode is at least approximately planar.
23. The liquid crystal display of claim 22, wherein the second subpixel electrode has a cutout formed proximate to at least one of its outer edges.
24. The liquid crystal display of claim 18, wherein the insulating layer has a plurality of openings corresponding to the first portion of the first subpixel electrode.
25. The liquid crystal display of claim 24, wherein the first portion of the second subpixel electrode includes a plurality of branch electrodes extending in a plurality of different directions.
26. The liquid crystal display of claim 25, wherein: at least part of the second portion of the second subpixel electrode is at least approximately planar.
27. The liquid crystal display of claim 26, wherein: the second subpixel electrode has a cutout formed proximate to at least one of its outer edges.
28. The liquid crystal display of claim 18, wherein: the first portion of the second subpixel electrode includes a plurality of branch electrodes extending in a plurality of different directions.

29. The liquid crystal display of claim **28**, wherein at least part of the second portion of the second subpixel electrode is at least approximately planar.

30. The liquid crystal display of claim **29**, wherein the second subpixel electrode has a cutout formed proximate to at least one of its outer edges.

* * * * *

专利名称(译)	液晶显示器具有多个像素区域以改善透射率		
公开(公告)号	US20140211142A1	公开(公告)日	2014-07-31
申请号	US14/090593	申请日	2013-11-26
[标]申请(专利权)人(译)	三星显示有限公司		
申请(专利权)人(译)	三星DISPLAY CO., LTD.		
当前申请(专利权)人(译)	三星DISPLAY CO., LTD.		
[标]发明人	KIM HOON KIM SU JEONG SHIN KI CHUL YANG DAN BI JUNG JAE HOON HAN MIN JU HONG JI PHYO		
发明人	KIM, HOON KIM, SU JEONG SHIN, KI CHUL YANG, DAN BI JUNG, JAE-HOON HAN, MIN JU HONG, JI PHYO		
IPC分类号	G02F1/1343		
CPC分类号	G02F1/134336 G02F1/133707 G02F1/134309 G02F1/13624 G02F2001/133742 G02F2001/134345 G02F2001/13712 G02F2203/30 G02F2203/64		
优先权	1020130010639 2013-01-30 KR		
其他公开文献	US9213205		
外部链接	Espacenet USPTO		

摘要(译)

根据本发明示例性实施例的液晶显示器包括：第一基板；第一子像素电极，位于第一基板上，用于接收第一电压；第二子像素电极，位于第一基板上，用于接收第二电压；绝缘层位于第一子像素电极和第二子像素电极之间；面向第一基板的第二基板；以及位于第二基板上的公共电极。第一子像素电极的一部分和第二子像素电极的一部分彼此重叠，绝缘层介于其间，并且第一电压和公共电压之间的差大于第二电压和公共电压之间的差。

