



US009335594B2

(12) **United States Patent**
Segawa et al.

(10) **Patent No.:** **US 9,335,594 B2**
(45) **Date of Patent:** ***May 10, 2016**

(54) **LIQUID CRYSTAL DISPLAY DEVICE HAVING IMPROVED ELECTROSTATIC DISCHARGE RESISTANCE**

(58) **Field of Classification Search**
CPC G02F 1/13452; G02F 1/136204; G02F 2202/22
USPC 349/34, 40, 141
See application file for complete search history.

(71) Applicant: **Japan Display Inc.**, Tokyo (JP)

(72) Inventors: **Yasuo Segawa**, Kitagata-cho (JP); **Masaaki Aota**, Ogaki (JP); **Tomohide Onogi**, Anparhi-cho (JP); **Hiroshi Matsuda**, Gifu (JP)

(56) **References Cited**

U.S. PATENT DOCUMENTS

5,953,092 A 9/1999 Sung et al.
6,143,418 A 11/2000 Takamiya et al.
6,259,502 B1 7/2001 Komatsu
6,346,932 B1 2/2002 Maeda

(Continued)

FOREIGN PATENT DOCUMENTS

CN 1198835 11/1998
JP 7-41586 7/1995

(Continued)

Primary Examiner — Hoan C Nguyen

(74) *Attorney, Agent, or Firm* — K&L Gates LLP

(73) Assignee: **Japan Display Inc.**, Tokyo (JP)

(*) Notice: Subject to any disclaimer, the term of this patent is extended or adjusted under 35 U.S.C. 154(b) by 0 days.

This patent is subject to a terminal disclaimer.

(21) Appl. No.: **14/447,243**

(22) Filed: **Jul. 30, 2014**

(65) **Prior Publication Data**

US 2014/0375919 A1 Dec. 25, 2014

Related U.S. Application Data

(63) Continuation of application No. 12/003,455, filed on Dec. 26, 2007, now Pat. No. 8,830,409.

(30) **Foreign Application Priority Data**

Dec. 27, 2006 (JP) 2006-352377

(51) **Int. Cl.**

G02F 1/1343 (2006.01)
G02F 1/1362 (2006.01)
G02F 1/1345 (2006.01)

(52) **U.S. Cl.**

CPC **G02F 1/136204** (2013.01); **G02F 1/13452** (2013.01); **G02F 2202/22** (2013.01)

(57) **ABSTRACT**

A liquid crystal display device includes a first substrate, a second substrate and liquid crystal. The first substrate includes pixel electrodes, a peripheral circuit and a dummy wiring. The peripheral circuit and the dummy wiring are provided outside a pixel area in which the pixel electrodes are arranged. The second substrate is opposed to the first substrate through the liquid crystal. The second substrate includes a translucent conductive film that is provided on an opposite side of the second substrate to a side where the liquid crystal is present. The dummy wiring is located on an outer peripheral side of the substrates than the peripheral circuit and is provided independently of the peripheral circuit in terms of circuit. The dummy wiring is grounded outside the first substrate.

17 Claims, 6 Drawing Sheets

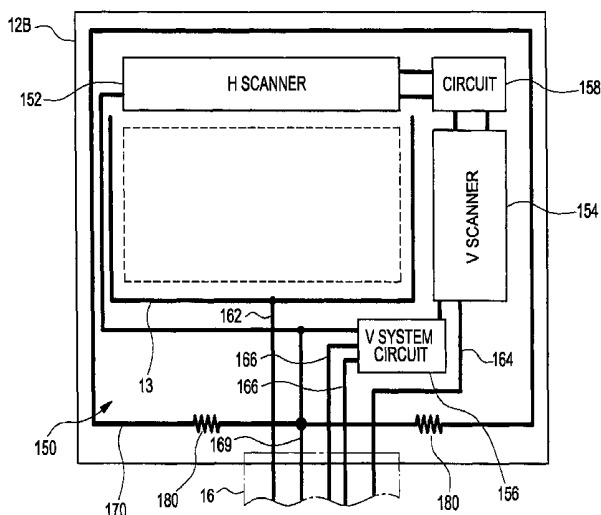

(56)

References Cited

U.S. PATENT DOCUMENTS

6,441,876	B1	8/2002	Wada et al.	
6,473,067	B2	10/2002	Maeda	
6,597,414	B1	7/2003	Hasegawa	
6,657,608	B2	12/2003	Maeda	
7,460,203	B2	12/2008	Kim	
7,663,726	B2*	2/2010	Takahashi	G02F 1/13452 349/138
2002/0126231	A1	9/2002	Zhang et al.	
2003/0218593	A1	11/2003	Inoue et al.	
2005/0082969	A1	4/2005	Tokuda et al.	
2005/0162605	A1*	7/2005	Murade	G02F 1/1345 349/152

2005/0230757	A1	10/2005	Nagasawa et al.	
2007/0080624	A1*	4/2007	Koiwa	H01J 29/868 313/495
2008/0137020	A1*	6/2008	Takahashi	G02F 1/13452 349/150

FOREIGN PATENT DOCUMENTS

JP	09-105918	4/1997
JP	10-268278	10/1998
JP	11-282011	10/1999
JP	2001-21918	1/2001
JP	2004-004754	1/2004
JP	2005-003816	1/2005

* cited by examiner

FIG. 1

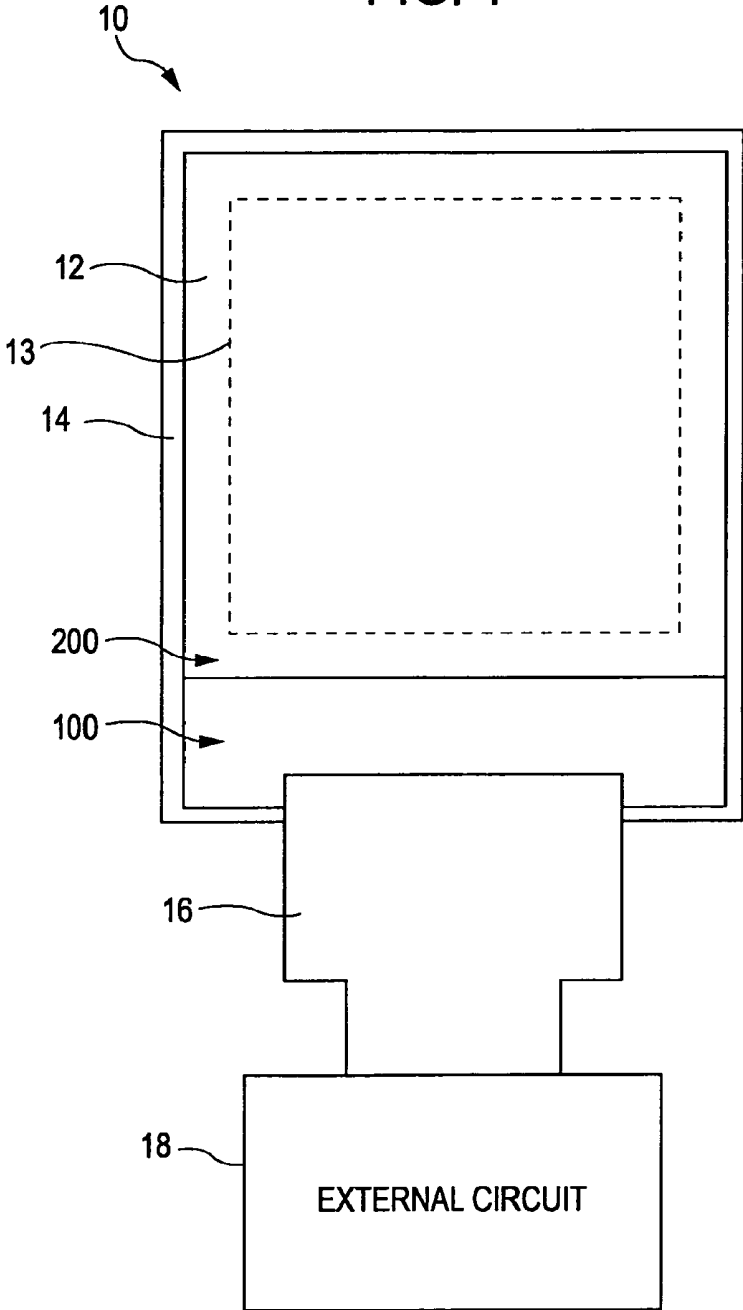

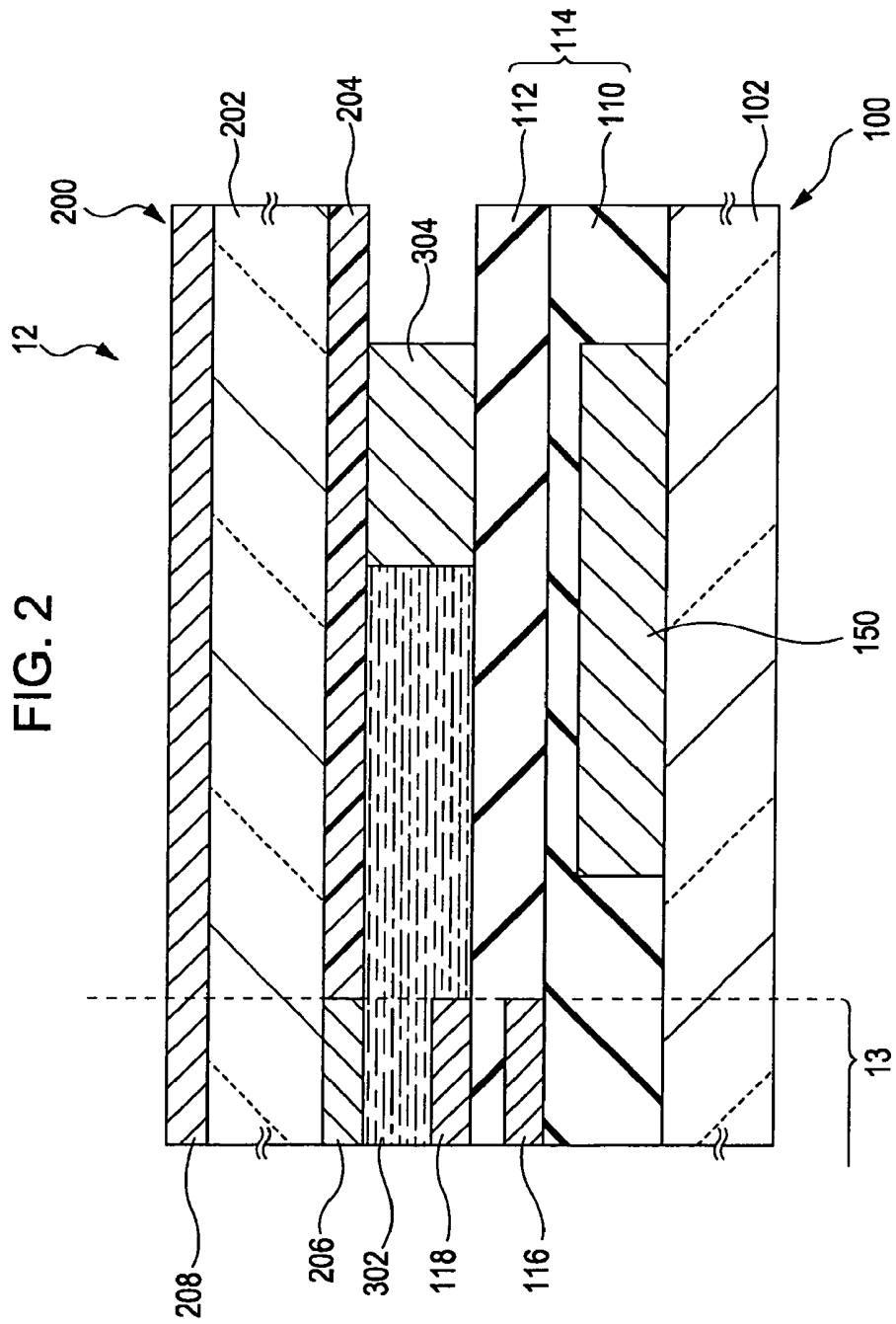

FIG. 4

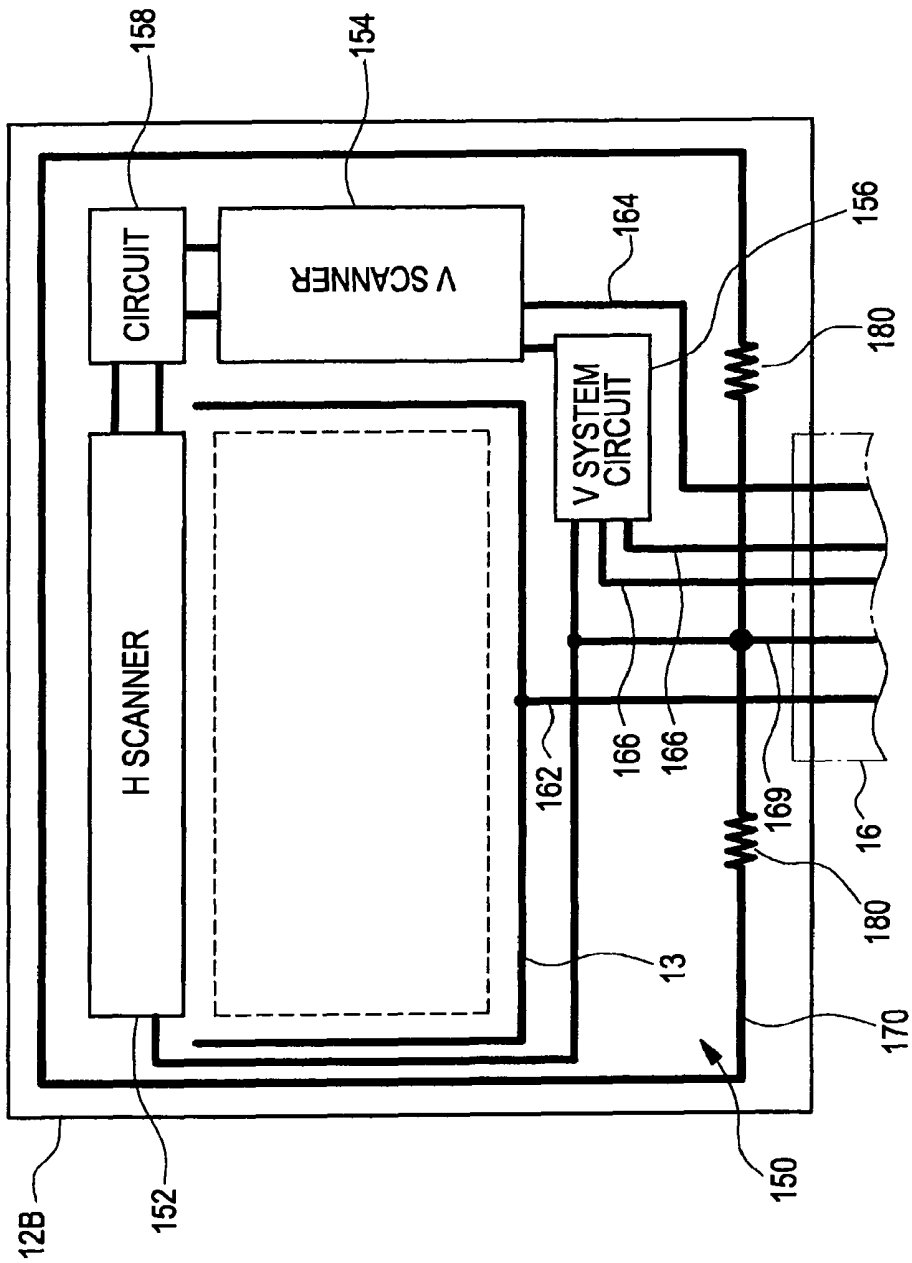

FIG. 5

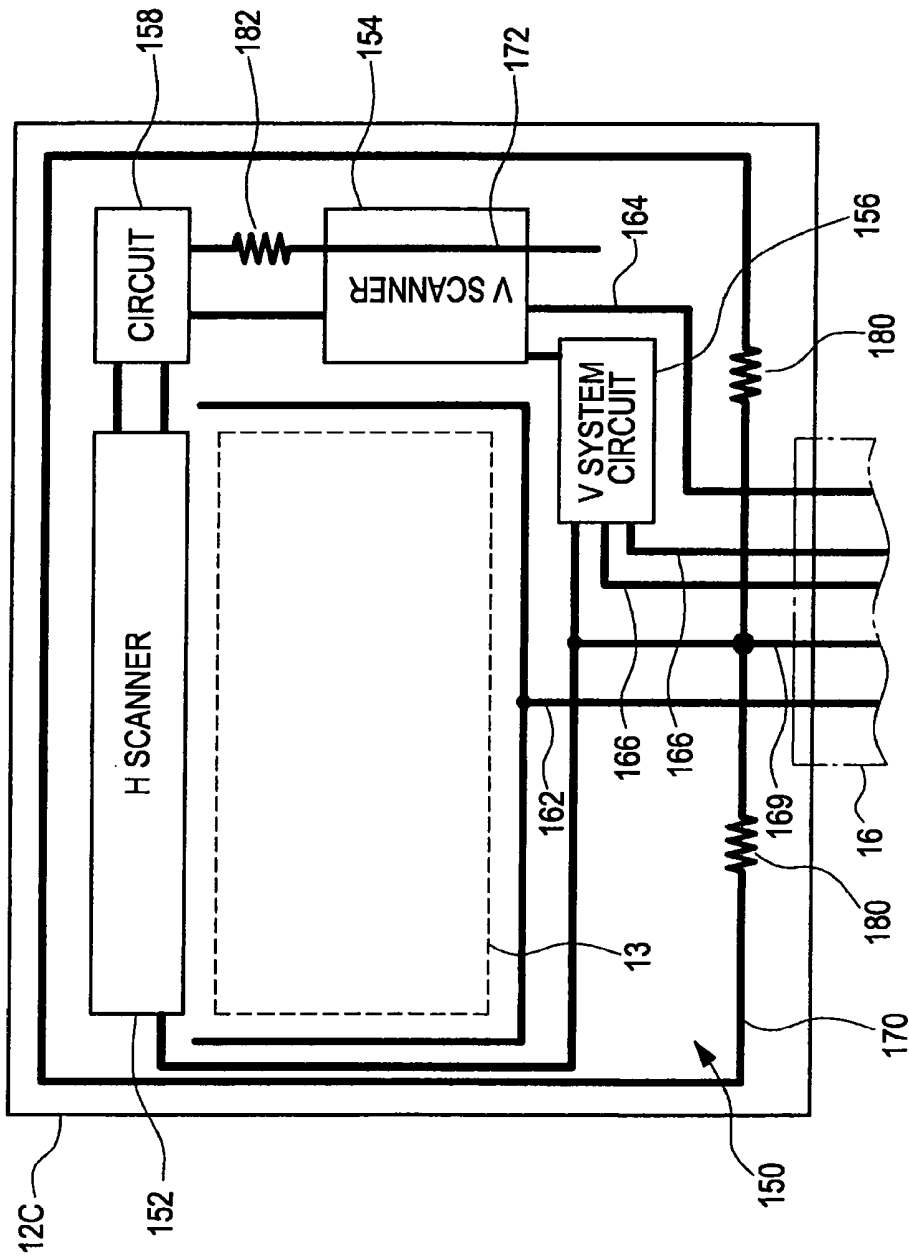

FIG. 6

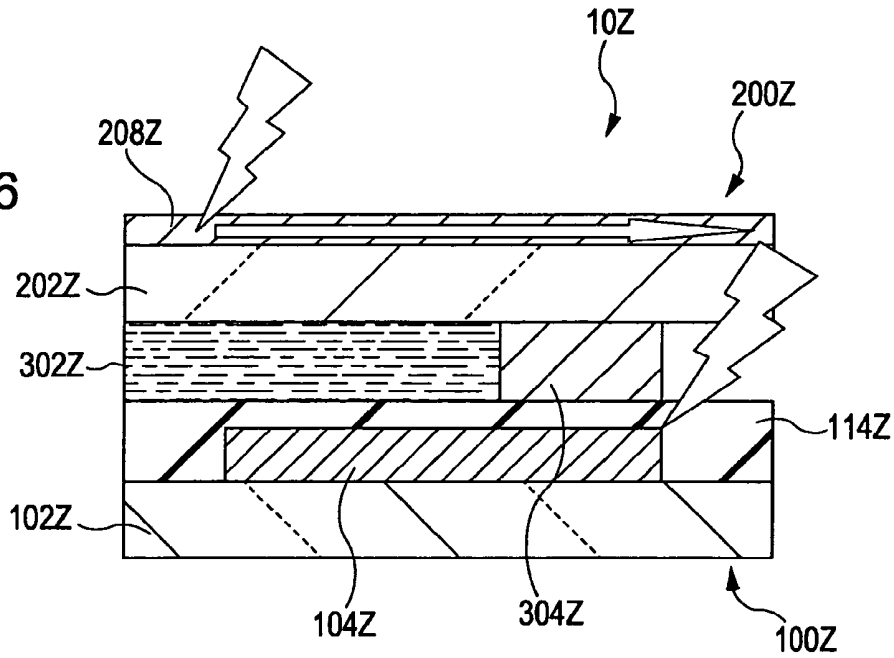
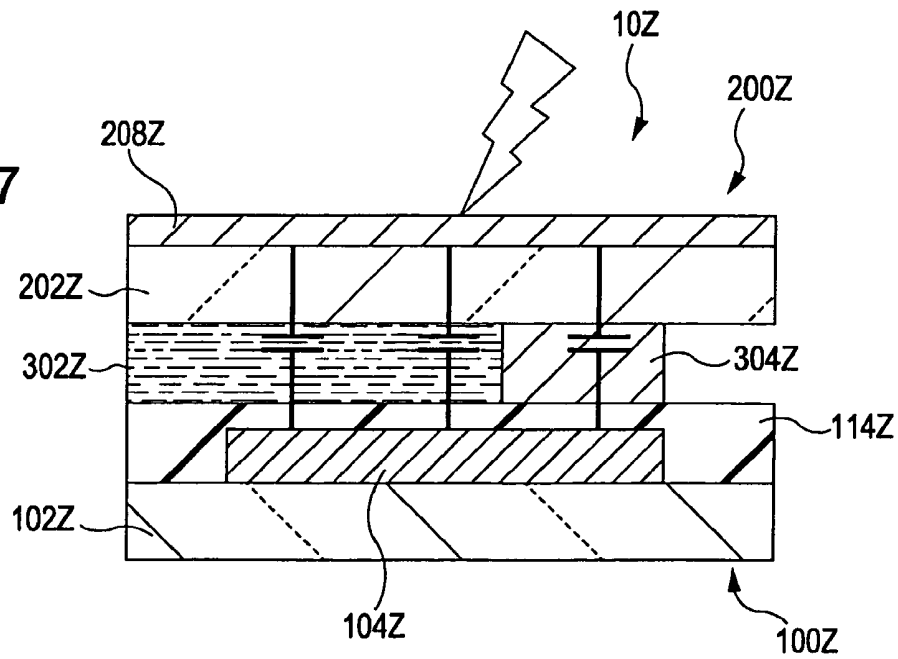

FIG. 7



LIQUID CRYSTAL DISPLAY DEVICE HAVING IMPROVED ELECTROSTATIC DISCHARGE RESISTANCE

CROSS REFERENCES TO RELATED APPLICATIONS

This application is a continuation application of U.S. patent application Ser. No. 12/003,455, filed Dec. 26, 2007, which application claims priority to Japanese Priority Patent Application JP 2006-352377 filed Dec. 27, 2006 in the Japan Patent Office on, the entire content of which is hereby incorporated by reference.

BACKGROUND

1. Technical Field

The present invention relates to a liquid crystal display device and, more particularly, to improvement in electrostatic discharge resistance of a liquid crystal display device.

2. Related Art

In a FFS (Fringe Field Switching) mode liquid crystal panel, a pixel electrode and a common electrode, which control the alignment of liquid crystal, both are provided in an element substrate, and these two electrodes are laminated through an insulating film. Of these electrodes, an upper layer electrode is provided with slits. A rubbing process is treated in a direction that is substantially parallel to a long side direction of the slits. When the electric potential between the electrodes is an off potential, liquid crystal molecules are aligned in a direction that is perpendicular to the long side direction of the slits. When an electric potential higher than the off potential is applied between the electrodes, an electric field (horizontal electric field) is generated in a direction perpendicular to the long sides of the slits, and liquid crystal molecules are rotated (horizontally rotated) in a plane parallel to the substrate along the direction of the electric field. By controlling the rotation angle of the liquid crystal molecules, the amount of light transmission is controlled.

Note that, in addition to the FFS mode, an IPS (In-Plane Switching) mode is known as a configuration in which both the pixel electrode and the common electrode are provided in the element substrate.

Liquid crystal panels have been progressively reduced in size, thickness, and window frame width, and progressively added with functions, such as a touch panel. In accordance with the above, static electricity from the outside of the panels through a human body, or the like, may cause a trouble in the panels.

For example, in the FFS mode, and the like, when an opposite substrate, which is opposed to an element substrate, is applied with static electricity and is electrostatically charged, there is a possibility that a vertical electric field is generated by the electrostatic charge and, hence, an appropriate alignment control on the liquid crystal using the electrodes provided in the element substrate cannot be performed. In this case, for example, in a normally black liquid crystal panel, a black display becomes whitish and the contrast is decreased. In addition, when a degree of whitish display is not uniform over the entire screen, display chrominance non-uniformity is observed.

As one of countermeasures to the above, there is a manner in which a translucent conductive film is formed over the entire outer surface of the opposite substrate, and this translucent conductive film is connected to a case or an FPC (Flexible Printed Circuit) terminal, thus releasing the electrostatic charge to the ground electric potential (GND) of an

external circuit, which is described in Japanese Unexamined Patent Application Publication No. 9-105918.

Even with the above countermeasure, however, it has been found that there is a possibility that a sufficient electrostatic discharge resistance cannot be obtained.

SUMMARY

An advantage of some aspects of the invention is that it provides a liquid crystal display device that improves electrostatic discharge resistance.

A first aspect of the invention provides a liquid crystal display device. The liquid crystal display device includes a first substrate, a second substrate and liquid crystal. The first substrate includes pixel electrodes, a peripheral circuit and a dummy wiring. The peripheral circuit and the dummy wiring are provided outside a pixel area in which the pixel electrodes are arranged. The second substrate is opposed to the first substrate through the liquid crystal. The second substrate includes a translucent conductive film that is provided on an opposite side of the second substrate to a side where the liquid crystal is present. The dummy wiring is located on an outer peripheral side of the substrates than the peripheral circuit and is provided independently of the peripheral circuit in terms of circuit. The dummy wiring is grounded outside the first substrate.

A second aspect of the invention provides a liquid crystal display device. The liquid crystal display device includes a first substrate, a second substrate and liquid crystal. The first substrate includes pixel electrodes, a peripheral circuit and a dummy wiring. The peripheral circuit and the dummy wiring are provided outside a pixel area in which the pixel electrodes are arranged. The second substrate is opposed to the first substrate through the liquid crystal. The second substrate includes a translucent conductive film that is provided on an opposite side of the second substrate to a side where the liquid crystal is present. The dummy wiring is connected to a power supply wiring through a protective resistance.

A third aspect of the invention provides a liquid crystal display device. The liquid crystal display device includes a first substrate, a second substrate and liquid crystal. The first substrate includes pixel electrodes and a peripheral circuit. The peripheral circuit is provided outside a pixel area in which the pixel electrodes are arranged. The second substrate is opposed to the first-substrate through the liquid crystal. The second substrate includes a translucent conductive film that is provided on an opposite side of the second substrate to a side where the liquid crystal is present. The peripheral circuit includes a power supply wiring that is connected to a control terminal of a circuit element through a protective resistance.

Here, the first substrate may further include at least one common electrode, wherein the translucent conductive film is maintained at a predetermined electric potential.

Additional features and advantages are described herein, and will be apparent from the following Detailed Description and the figures.

BRIEF DESCRIPTION OF THE FIGURES

FIG. 1 is a schematic view of a liquid crystal display device according to an embodiment of the invention.

FIG. 2 is a cross-sectional view of a liquid crystal panel according to the embodiment of the invention.

FIG. 3 is a plan view that illustrates a first example of the liquid crystal panel according to the embodiment of the invention.

FIG. 4 is a plan view that illustrates a second example of the liquid crystal panel according to the embodiment of the invention.

FIG. 5 is a plan view that illustrates a third example of the liquid crystal panel according to the embodiment of the invention.

FIG. 6 is a cross-sectional view that illustrates an influence of static electricity according to an existing FFS mode liquid crystal display device.

FIG. 7 is a cross-sectional view that illustrates an influence of static electricity according to an existing FFS mode liquid crystal display device.

DETAILED DESCRIPTION

Embodiments of the present application will be described below in detail with reference to the drawings.

Before describing embodiments according to the invention, electrostatic discharge resistance has been considered on the basis of various evaluations. This will be described with reference to FIG. 6 and FIG. 7 illustrating the cross-sectional views around peripheral portions of a liquid crystal display device.

As shown in FIG. 6 and FIG. 7, in an existing FFS mode liquid crystal display device 10Z, a first substrate 100Z and a second substrate 200Z are adhered to each other by a seal 304Z, and liquid crystal 302Z is held between these substrates 100Z, 200Z. A circuit wiring group 104Z is arranged on a support substrate 102Z of the first substrate 100Z, and an insulating film 114Z is arranged so as to cover the circuit wiring group 104Z. Note that the circuit wiring group 104Z is schematically shown in the drawing. A translucent conductive film 208Z is arranged on an outer surface of a support substrate 202Z of the second substrate 200Z, and this translucent conductive film 208Z extends over the entire surface of the above outer surface, that is, to the outer periphery of the support substrate 202Z, that is, to the outer periphery of the second substrate 200z. Note that, for example, by forming the translucent conductive film 208Z over the entire surface of a substrate, which includes multiple number of unit substrates, and then separating the substrate into the unit substrates, the translucent conductive film 208Z is formed so as to extend to the outer periphery of the second substrate 200Z.

When aerial discharge has been performed on the translucent conductive film 208Z, aerial discharge that is generated at the outer peripheral portion of the translucent conductive film 208Z, as shown in FIG. 6, was observed, and breakage was found in the circuit wiring group 104Z and circuit elements connected thereto. According to the above, it is conceivable that static electricity is transmitted from the outer peripheral portion of the translucent conductive film 208Z through the side of the outer peripheral portion of the second substrate 200Z to the circuit wiring group 104Z. In this case, of the circuit wiring group 104Z, static electricity tends to be transmitted to a circuit wiring closer to the outer periphery of the substrate.

In addition, breakage also found in a circuit wiring remote from the outer periphery of the substrate and circuit elements connected thereto. It is conceivable that this breakage occurs because the electric potential of the translucent conductive film 208Z rises due to static electricity that has entered the translucent conductive film 208Z, and then the electric potential of the circuit wiring group 104Z rises due to coupling with the electric potential rise of the translucent conductive film 208Z. That is, it is conceivable that the breakage occurs due to the transmission of static electricity on the basis of coupling (see FIG. 7). Note that FIG. 7 is a schematic view illustrating

a state of coupling using the graphic symbols of capacitors. The coupling with the translucent conductive film 208Z tends to occur as the area of wiring pattern is increased, that is, the width and/or length, or the like, of wiring is increased. It is conceivable that, for example, the coupling tends to occur with a power supply wiring that has a wide line width for reducing a resistance.

In addition, it has been found that breakage tends to occur more likely in the circuit wiring that extends along the outer periphery of the substrate than in the circuit wiring that extends in a direction which intersects with the outer periphery of the substrate.

An embodiment according to the invention will now be described with reference to the accompanying drawings. FIG. 1 is a schematic view of a liquid crystal display device 10 according to the embodiment. Note that, for easily understanding the drawings, components that are shown in FIG. 1 and in the following drawings, when they are shown in the other drawings as well, are partially omitted.

As shown in FIG. 1, the liquid crystal display device 10 is configured to include a liquid crystal panel 12, a case 14 for the liquid crystal panel 12, an FPC 16, and an external circuit 18. The liquid crystal panel 12 is connected to the external circuit 18 through the FPC 16. In place of the FPC 16, various wiring bodies may be used. The following will exemplify a case where the liquid crystal panel 12 uses an FFS mode. Note that the liquid crystal panel 12 may be any one of a transmissive type liquid crystal panel, a reflective type liquid crystal panel and a transfective type liquid crystal panel.

FIG. 2 is a cross-sectional view around an outer periphery of the liquid crystal panel 12. The liquid crystal panel 12 is configured to include a first substrate 100, a second substrate 200, liquid crystal 302 and a seal 304. The substrates 100, 200 are opposed to each other with a predetermined gap formed therebetween, and are adhered to each other at the peripheral portions by the seal 304. The liquid crystal 302 is held in a casing that is formed of the substrates 100, 200 and the seal 304.

The first substrate 100 includes a support substrate 102 that is, for example, formed of a translucent substrate, such as glass, and is configured to include, on the inner surface side of the support substrate 102, that is, on the side adjacent to the liquid crystal 302, insulating films 110, 112, at least one common electrode 116, pixel electrodes 118, a peripheral circuit 150, and an alignment layer (not shown).

The common electrode 116 and the pixel electrodes 118 are paired electrodes that control the alignment of the liquid crystal 302, that is, that drive the liquid crystal 302. The common electrode 116 is commonly provided for a plurality of pixels, and each of the pixel electrodes 118 is provided for each of the pixels. An electric potential corresponding to a display of each pixel is supplied to the pixel electrode 118. Note that it may also be configured that the common electrode 116 is provided for each of the pixels and then a common electric potential is supplied to the common electrode 116. That is, the plurality of pixels are formed of the plurality of pixel electrodes 118 and the at least one common electrode 116. Note that the outermost pixels, arranged all around, or more number of pixels, may possibly be used as dummy pixels that do not directly contribute to image display.

In the FFS mode liquid crystal panel 12, the electrodes 116, 118 both are provided in the first substrate 100, and the electrodes 116, 118 are laminated through the insulating film 112. The following will exemplify a case where the pixel electrodes 118 are arranged in an upper side layer, that is, on the side adjacent to the liquid crystal 302; however, the common electrodes 116 may be arranged in the upper side layer.

Slits (not shown) are formed in each of the upper layer pixel electrodes **118**, and the alignment of the liquid crystal **302** is controlled by an electric field generated between the electrodes **116**, **118** through the slits. The electrodes **116**, **118** are, for example, formed of a translucent conductive film, such as ITO (Indium Tin Oxide).

The peripheral circuit **150** is a circuit that is arranged outside the electrodes **116**, **118** and the pixel area **13**. Here, the pixel area **13** is an area in which a plurality of the pixels are arranged. In other words, the plurality of pixels are arranged in the pixel area **13**. Note that an area for the dummy pixels also included in the pixel area **13**. The peripheral circuit **150** will be exemplified later.

The insulating films **110**, **112** are, for example, formed of silicon oxide, silicon nitride, or the like, and are laminated on the support substrate **102**. Note that, for easy description, it exemplifies a case where the insulating film **110** is located in a layer lower than the common electrode **116**, that is, the layer adjacent to the support substrate **102**, and the insulating film **112** is laminated on the insulating film **110**; however, these insulating films **110**, **112** are collectively called as an insulating film **114**. The insulating films **110**, **112** each may be a monolayer film or may be a multilayer film. The alignment layer (not shown) is arranged to cover the pixel electrodes **118**, and the alignment layer is treated with a rubbing process.

Note that FIG. 2 exemplifies a case where the peripheral circuit **150** is in contact with the support substrate **102** and is covered with the insulating film **110**; however, it may be configured so that the peripheral circuit **150** is embedded in the insulating film **114** formed of a multilayer film and is not in contact with the support substrate **102**.

The second substrate **200** includes a support substrate **202** that is, for example, formed of a translucent substrate, such as glass, and is configured to include, on the inner surface side of the support substrate **202**, that is, on the side adjacent to the liquid crystal **302**, a light shielding film **204**, a color filter **206** and an alignment layer (not shown) and to include, on the outer surface side of the support substrate **202**, that is, on the side opposite to the liquid crystal **302**, a translucent conductive film **208**.

The support substrate **202** is opposed to the first substrate **100**, and has a size to be opposed to be opposed to the electrodes **116**, **118** and the peripheral circuit **150**. The light shielding film **204** is arranged on the support substrate **202**. The light shielding film **204** extends over the entire surface on the support substrate **202** and has an opening at a position opposite each of the pixel electrodes **118**. Note that no opening is provided at a position opposite each of the dummy pixels. The light shielding film **204** is, for example, formed of a resin, or the like, containing black pigment. The color filter **206** is arranged on the support substrate **202** and is provided in each opening portion of the light shielding film **204** so as to be opposed to the electrodes **116**, **118**. The alignment layer (not shown) is arranged to cover the light shielding film **204** and the color filter **206**, and the alignment layer is treated with a rubbing process.

The translucent conductive film **208** is arranged on the outer surface of the support substrate **202** and is opposed to the liquid crystal **302** and the electrodes **116**, **118**, and the like, through the substrate **202**. That is, the translucent conductive film **208** is provided in the second substrate **200** and is located on an opposite side to a surface that is in contact with the liquid crystal **302**. The translucent conductive film **208** is maintained at an arbitrarily predetermined electric potential, for example, a ground electric potential, and releases static electricity, which enters from the outside of the panel toward the second substrate **200**, thus preventing electrostatic charge

of the second substrate **200**. That is, the translucent conductive film **208** serves as a shielding film. Thus, it is possible to suppress a trouble due to electrostatic charge of the second substrate **200**, that is, for example, a decrease in contrast and chrominance non-uniformity. The translucent conductive film **208** may be provided without patterning (without any gaps), or, as long as the body portion **208a** achieves a shielding effect against static electricity, it may be patterned to form a mesh.

The translucent conductive film **208** is, for example, formed of ITO, or the like, and may be formed of any one of an inorganic material or an organic material. The translucent conductive film **208** may be formed by a process, such as a sputtering process, a plasma CVD (Chemical Vapor Deposition) process, a spin coating process, and a printing process. The translucent conductive film **208** has a resistivity (sheet resistance) of, for example, $105\Omega/\square$, which is preferably as low as possible. Note that it exemplifies a case where the outer periphery of the translucent conductive film **208** extends to the outer periphery of the support substrate **202**, that is, to the outer periphery of the second substrate **200**; however, an area, in which the translucent conductive film **208** is arranged, is not limited to this.

The liquid crystal panel **12** will now be exemplified. FIG. 3 to FIG. 5 are plan views that illustrate liquid crystal panels **12A** to **12C** according to first example to third example. Note that, for avoiding complicated drawing, an area outside the pixel area **13** is shown wide, and a connection state, or the like, of a wiring is partially omitted from the drawing.

In the liquid crystal panel **12A** that is exemplified in FIG. 3, the peripheral circuit **150** is configured to include an H scanner **152**, a V scanner **154**, a V system circuit **156**, a circuit **158**, a COM wiring **162**, wirings **164**, **166**, and the like.

The H scanner **152** and the V scanner **154** are circuits for scanning pixels horizontally and vertically on a display screen. The V system circuit **156** is, for example, a level shifter, and is connected to the V scanner **154**. The circuit **158** is, for example, a control circuit, a signal processing circuit, a detection circuit, and the like. Here, the circuit **158** is connected to the scanners **152**, **154**. The COM wiring **162** is a wiring that supplies an electric potential (common electric potential) to be applied to the common electrode **116** (see FIG. 2). The COM wiring **162** extends from the end, which is connected to the FPC **16**, toward the pixel area **13**. Here, the COM wiring **162** extends from a portion near the pixel area **13** along three sides of the area **13**. The wiring **164** is a control signal wiring for the V scanner **154** and extends from the end, which is connected to the FPC **16**, toward the V scanner **154**. The wiring **166** is, for example, an input signal wiring to the V system circuit **156** and extends from the end, which is connected to the FPC **16**, toward the V system circuit **156**. Note that FIG. 3 exemplifies a case where the two wirings **166** are provided.

The liquid crystal panel **12A** includes a dummy wiring **168** outside the pixel area **13**. The dummy wiring **168** is arranged on the outer peripheral side of the substrate than the peripheral circuit **150** that is configured to include the scanners **152**, **154**, and the like. The dummy wiring **168** is a wiring that is located on the outermost periphery among various wirings of the liquid crystal panel **12A**. In addition, the dummy wiring **168** is not connected to the peripheral circuit **150**, that is, the dummy wiring **168** is provided independently of the peripheral circuit **150** in terms of circuit. According to the above arrangement and connection state, the dummy wiring **168** does not intersect with the peripheral circuit **150**. The dummy wiring **168** surrounds the peripheral circuit **150**. The dummy wiring **168** preferably avoids an intersection with the periph-

eral circuit 150 also at a portion connected to the FPC 16. In this case, the dummy wiring 168 does not constitute a closed path (closed loop) within the liquid crystal panel 12A, and both ends of the dummy wiring 168 are pulled out to the portion connected to the FPC 16. Both end portions of the dummy wiring 168 are connected through the FPC 16 to the ground electric potential of the external circuit 18. Both end portions of the dummy wiring 168 may be connected to the ground electric potential through a resistance of 10 kΩ to 1 mΩ.

According to the above configuration, even when static electricity enters from the outer peripheral portion of the translucent conductive film 208 over the side face of the support substrate 202 to the first substrate 100, it is possible to flow the static electricity through the dummy wiring 168 to the ground electric potential of the external circuit 18. Thus, it is possible to suppress transmission of static electricity to the peripheral circuit 150, and electrostatic discharge resistance is improved.

The dummy wiring 168 does not intersect with the peripheral circuit 150. For this reason, static electricity entering the dummy wiring 168 is suppressed from being transmitted to the peripheral circuit 150 due to coupling. Thus, electrostatic discharge resistance is improved.

Because the dummy wiring 168 is connected to the ground electric potential of the external circuit 18, the ground electric potential may possibly rise when static electricity enters the dummy wiring 168. However, in terms of a signal, a power supply electric potential, or the like, to which a voltage value is set relatively to the ground electric potential as a reference, an influence of a rise in ground electric potential is suppressed. Therefore, electrostatic discharge resistance is improved in comparison with a case where the dummy wiring 168 is, for example, connected to the ground electric potential of the liquid crystal panel 12A.

In the liquid crystal panel 12B as exemplified in FIG. 4, the peripheral circuit 150 is configured to include the H scanner 152, the V scanner 154, the V system circuit 156, the circuit 158, the COM wiring 162, the wirings 164, 166, a power supply wiring 169, and the like. In addition, the liquid crystal panel 12B includes a dummy wiring 170 and protective resistances 180. Note that the same reference numerals are assigned to the same or similar components described above, and a description thereof is omitted.

The power supply wiring 169 is, for example, a wiring that supplies a power supply electric potential V_{ss}, and extends from the end, which is connected to the FPC 16, to be connected to the V system circuit 156 and the H scanner 152. Note that the electric potential V_{ss} is, for example, supplied through the V system circuit 156 to the V scanner 154 and supplied through the H scanner 152 to the circuit 158.

The dummy wiring 170 is connected through the resistance 180 to the power supply wiring 169, and extends around the panel and then is connected through the other resistance 180 to the power supply wiring 169 again. Here, the dummy wiring 170 is located on the outermost periphery than various wirings of the peripheral circuit 150. The dummy wiring 170 surrounds the scanners 152, 154, the V system circuit 156, the circuit 158, and the like. The dummy wiring 170 extends along the outer periphery of the substrate to form a closed loop in the liquid crystal panel 12B.

The protective resistances 180 have a resistance value of, for example, 10 kΩ to 10 MΩ. The protective resistances 180 may be, for example, formed by using a silicon film.

According to the above configuration, even when static electricity enters from the outer peripheral portion of the translucent conductive film 208 over the side face of the

support substrate 202 to the dummy wiring 170, which is the outermost wiring of the first substrate 100, the static electricity is consumed in the protective resistances 180. In addition, even when static electricity entering the translucent conductive film 208 causes fluctuation in electric potential of the dummy wiring 170 due to coupling, the fluctuation in electric potential is consumed by the protective resistances 180. For this reason, the entered static electricity is suppressed from being transmitted to a circuit element, such as the scanner 152. Thus, electrostatic discharge resistance is improved.

In the liquid crystal panel 12C as exemplified in FIG. 5, the peripheral circuit 150 includes, in addition to the above configuration exemplified in FIG. 4, a power supply wiring 172 and a protective resistance 182. The power supply wiring 172 and the protective resistance 182 are arranged inside the above closed loop portion of the dummy wiring 17 in the liquid crystal panel 12C. Note that the same reference numerals are assigned to the same or similar components described above, and a description thereof is omitted.

The power supply wiring 172 is a wiring that supplies a power supply electric potential used in the V scanner 154 and in the circuit 158. Note that the power supply electric potential may be an electric potential that is generated in the liquid crystal panel 12C, or may be an electric potential that is supplied from the external circuit 18 (see FIG. 1), or the like. The power supply wiring 172 passes through the V scanner 154 and extends along the outer periphery of the substrate, and then is connected through the protective resistance 182 to the circuit 158. The protective resistance 182 has a resistance value of, for example, 10 kΩ to 10 MΩ. The protective resistance 182 may be, for example, formed by using a silicon film.

The circuit 158 in the liquid crystal panel 12C uses the above power supply electric potential that is supplied by the power supply wiring 172 as a control signal. For example, the circuit 158 may be a signal processing circuit, a detection circuit, or the like, that is shared by the H scanner 152 and the V scanner 154. When the power supply electric potential is supplied through the power supply wiring 172, the circuit 158 is switched to a circuit for the V scanner 154. When no power supply electric potential is supplied, the circuit 158 is switched to a circuit for the H scanner 152. The thus switching may be, for example, achieved by using a switching element, such as a MOS (Metal Oxide Semiconductor) transistor, and the power supply wiring 172 is connected to a control terminal of the switching element, that is, for example, the gate of the MOS transistor.

Particularly, the protective resistance 182 is connected in the power supply wiring 172 in a midway of the path from the V scanner 154 to the control terminal, and the protective resistance 182 is provided upstream of the control terminal.

According to the above configuration, even when static electricity entering the translucent conductive film 208 causes fluctuation in electric potential of the power supply wiring 172 due to coupling, the fluctuation in electric potential is consumed by the protective resistance 182. In addition, even when static electricity enters from the outer peripheral portion of the translucent conductive film 208 over the side face of the support substrate 202 to the power supply wiring 172 of the first substrate 100, the static electricity is consumed in the protective resistance 182. For this reason, the entered static electricity is suppressed from being transmitted to the control circuit of the switching element. Thus, electrostatic discharge resistance is improved.

Here, in light of the evaluation that static electricity tends to be transmitted to a wiring that extends along the outer periphery of the substrate, electrostatic discharge resistance is reli-

ably improved by connecting the protective resistances **180**, **182** to the wirings **170**, **172**, respectively.

In addition, the wirings **170**, **172** to which the protective resistances **180**, **182** are connected and the dummy wiring **168** may be variously combined, and, thereby, it is possible to further improve electrostatic discharge resistance. Furthermore, the dummy wiring **168** and the wirings **170**, **172**, to which the protective resistances **180**, **182** are connected, are effective against static electricity that enters the first substrate **100** without passing through the translucent conductive film **208**.

Moreover, the above description exemplifies the FFS mode in which the electrodes **116**, **118** that drive the liquid crystal **302** are laminated through the insulating film **112**. However, it may be configured as an IPS mode in which both electrodes **116**, **118** are arranged in the same layer (for example, on the insulating film **112**). When in the IPS mode, for example, the electrodes **116**, **118** having a comb-shaped pattern are arranged so that the comb-shaped portions are alternately meshed with each other. In addition, the above configured liquid crystal display device **10** may be applied to a liquid crystal display device, such as a TN (Twisted Nematic) mode, in which the common electrode **116** is opposed to the pixel electrodes **118** through the liquid crystal **302**.

It should be understood that various changes and modifications to the presently preferred embodiments described herein will be apparent to those skilled in the art. Such changes and modifications can be made without departing from the spirit and scope of the present subject matter and without diminishing its intended advantages. It is therefore intended that such changes and modifications be covered by the appended claims.

The application is claimed as follows:

1. A display device comprising:
 - a first substrate having a pixel area in which a plurality of pixels are arranged, and including a peripheral circuit, and a dummy wiring being provided outside the pixel area,
 - wherein the dummy wiring is made of a continuous metal layer surrounding the pixel area and the peripheral circuit,
 - wherein the dummy wiring is located between the peripheral circuit and an outermost edge of the first substrate and is not electrically connected to the peripheral circuit within the first substrate,
 - wherein the dummy wiring is connected to a reference potential outside the first substrate,
 - wherein each of the pixels includes a pixel electrode and a common electrode that are formed on the first substrate, and
 - wherein the common electrode is not electrically connected to the dummy wiring.
2. The display device according to claim 1, wherein the peripheral circuit is configured from a horizontal scan drive circuit and a vertical scan drive circuit.
3. The display device according to claim 2, further comprising a control circuit connected to both the horizontal scan drive circuit and the vertical scan drive circuit.
4. The display device according to claim 1, wherein a common wiring is positioned around a plurality of sides of the pixel area between the pixel area and the dummy wiring.
5. The display device according to claim 1, further comprising a second substrate formed opposite to the first substrate, the second substrate including a translucent conductive film that extends to at least one outermost edge of the second substrate.

6. The display device according to claim 5, wherein the translucent conductive film and the dummy wiring are configured and arranged such that static electricity entering from an outer peripheral portion of the translucent conductive film over a side face of the second substrate flows through the dummy electrode to the reference potential.

7. The display device according to claim 5, wherein the translucent conductive film is connected to the same reference potential as the dummy wiring.

8. The display device according to claim 1, wherein the dummy wiring does not intersect the peripheral circuit in plan view.

9. The display device according to claim 1, wherein the dummy wiring does not form a closed loop in plan view, and two different ends of the dummy wiring are connected to the same reference potential.

10. The display device according to claim 1, wherein the dummy wiring forms a closed loop in plan view.

11. The display device according to claim 10, wherein the peripheral circuit includes a power supply wiring, and two ends of the dummy wiring are connected to the power supply wiring through different electrical resistance elements.

12. The display device according to claim 11, further comprising a second substrate formed opposite to the first substrate, the second substrate including a translucent conductive film that extends to at least one outermost edge of the second substrate, wherein the translucent conductive film, the dummy wiring, and the electrical resistance elements are configured and arranged such that an amount of static electricity entering from an outer peripheral portion of the translucent conductive film over a side face of the second substrate is reduced by the electrical resistance elements.

13. The display device according to claim 1, wherein the dummy wiring extends outside the display device.

14. The display device according to claim 1, wherein the dummy wiring surrounds all of at least three sides of the pixel area and surrounds at least part of a fourth side of the pixel area.

15. A liquid crystal display device comprising:

- a first substrate having a side and including pixel electrodes, a peripheral circuit, at least one common electrode, and a dummy wiring, the peripheral circuit and the dummy wiring being provided outside a pixel area in which the pixel electrodes are arranged, the peripheral circuit being arranged along the side of the first substrate;
- a second substrate that includes a translucent conductive film provided at an opposite side of the second substrate to a side where the liquid crystal is present; and
- a liquid crystal layer formed between the first and second substrate,

 wherein the peripheral circuit includes a common wiring supplying a common electric potential to the at least one common electrode, the common wiring being separate from the dummy wiring,

- wherein the dummy wiring is located close to an outermost edge of the first substrate,
- wherein the dummy wiring is made of a continuous metal layer surrounding the pixel area and peripheral circuit to ground the static electricity,
- wherein the dummy wiring is located between the peripheral circuit and the outermost edge of the side at which the peripheral circuit is positioned and is not electrically connected to the peripheral circuit within the first substrate,

wherein the dummy wiring is connected to a ground potential outside the first substrate and the dummy wiring surrounds the peripheral circuit on at least three sides of the first substrate,

wherein the dummy wiring discharges an electric potential rise on the first substrate, and

wherein the common electrode is not electrically connected to the dummy wiring.

16. The liquid crystal display device according to claim **15**, wherein the peripheral circuit is configured from a horizontal scan drive circuit and a vertical scan drive circuit.

17. The liquid crystal display device according to claim **16**, further comprising a control circuit connected to both the horizontal scan drive circuit and the vertical scan drive circuit.

* * * * *

专利名称(译)	具有改善的抗静电电性的液晶显示装置		
公开(公告)号	US9335594	公开(公告)日	2016-05-10
申请号	US14/447243	申请日	2014-07-30
[标]申请(专利权)人(译)	日本显示器西股份有限公司		
申请(专利权)人(译)	日本展示WEST INC.		
当前申请(专利权)人(译)	日本展示INC.		
[标]发明人	SEGAWA YASUO AOTA MASAOKI ONOGI TOMOHIDE MATSUDA HIROSHI		
发明人	SEGAWA, YASUO AOTA, MASAOKI ONOGI, TOMOHIDE MATSUDA, HIROSHI		
IPC分类号	G02F1/1343 G02F1/1345 G02F1/1362		
CPC分类号	G02F1/136204 G02F1/13452 G02F1/134363 G02F1/134309 G02F1/133707 G02F2202/22 G02F2001/134381		
优先权	2006352377 2006-12-27 JP		
其他公开文献	US20140375919A1		
外部链接	Espacenet USPTO		

摘要(译)

一种液晶显示装置，包括第一基板，第二基板和液晶。第一基板包括像素电极，外围电路和虚设布线。外围电路和虚设布线设置在布置有像素电极的像素区域的外部。第二基板通过液晶与第一基板相对。第二基板包括半透明导电膜，该半透明导电膜设置在第二基板的与存在液晶的一侧相对的一侧。虚设布线位于基板的外周侧而不是外围电路，并且在电路方面独立于外围电路而设置。虚设布线在第一基板外部接地。

