



US008432514B2

(12) **United States Patent**
Kim

(10) **Patent No.:** **US 8,432,514 B2**
(45) **Date of Patent:** **Apr. 30, 2013**

(54) **LIQUID CRYSTAL DISPLAY**
(75) Inventor: **Dong-Gyu Kim**, Suwon (KR)
(73) Assignee: **Samsung Display Co., Ltd.** (KR)

5,686,932 A 11/1997 Tomita
5,877,830 A 3/1999 Shimada et al.
5,999,155 A 12/1999 Satou
6,014,193 A 1/2000 Taira et al.
6,577,295 B2 6/2003 Kikkawa

(*) Notice: Subject to any disclaimer, the term of this patent is extended or adjusted under 35 U.S.C. 154(b) by 0 days.

FOREIGN PATENT DOCUMENTS
JP 61-026921 2/1986
JP 61-32087 A 2/1986
JP 01-197722 8/1989
JP 04-198921 7/1992
JP 06-337438 A 12/1994
JP 09-96839 4/1997
JP 09-160015 A 6/1997

(21) Appl. No.: **13/193,508**
(22) Filed: **Jul. 28, 2011**

(Continued)

(65) **Prior Publication Data**
US 2011/0278607 A1 Nov. 17, 2011

OTHER PUBLICATIONS

Patent Abstracts of Japan, Publication No. 09-96839, Apr. 8, 1997, 2 pp.

Related U.S. Application Data

(60) Division of application No. 11/244,099, filed on Oct. 6, 2005, which is a continuation of application No. 09/615,794, filed on Jul. 13, 2000, now abandoned.

(Continued)

(30) **Foreign Application Priority Data**

Jul. 13, 1999 (KR) 99-28287
Nov. 5, 1999 (KR) 99-48841
Dec. 31, 1999 (KR) 99-67761

Primary Examiner — Timothy L Rude

(74) *Attorney, Agent, or Firm* — Innovation Counsel LLP

(51) **Int. Cl.**
G02F 1/1333 (2006.01)

(52) **U.S. Cl.**
USPC **349/110**

(58) **Field of Classification Search** 349/110
See application file for complete search history.

(57) **ABSTRACT**

A liquid crystal display includes first and second insulating substrates facing each other, and a plurality of pixels comprising a plurality of rows and a plurality of columns and divided into a first pixel group comprising only the pixels on a first row and a second pixel group comprising each of the remaining pixels on second to last rows. The pixels of the first pixel group have a first opening ratio, and the pixels of the second pixel group have a second opening ratio different from the first opening ratio. The first opening ratio is smaller than the second opening ratio, and the first opening ratio is about 60% to about 80% of the second opening ratio; and the pixels of the first pixel group but not the pixels of the second pixel group have a light interception pattern in an opening portion.

(56) **References Cited**

U.S. PATENT DOCUMENTS

4,955,697 A 9/1990 Tsukada et al.
5,513,028 A 4/1996 Sono et al.
5,646,756 A 7/1997 Dohjo et al.

4 Claims, 24 Drawing Sheets

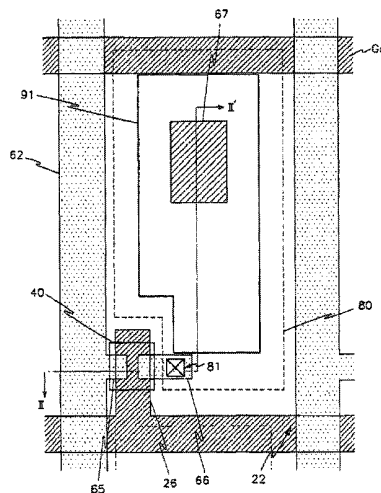

FOREIGN PATENT DOCUMENTS

JP 09-211480 8/1997
JP 09-311351 A 12/1997
JP 10-020335 A 1/1998
JP 10-062812 A 3/1998
JP 11-133455 A 5/1999

KR 10-1998-74474 11/1998
KR 10-2004-58835 B1 11/2004

OTHER PUBLICATIONS

Korean Patent Abstracts, 10-1998-74474, Nov. 5, 1998, 1 p.

FIG. 1

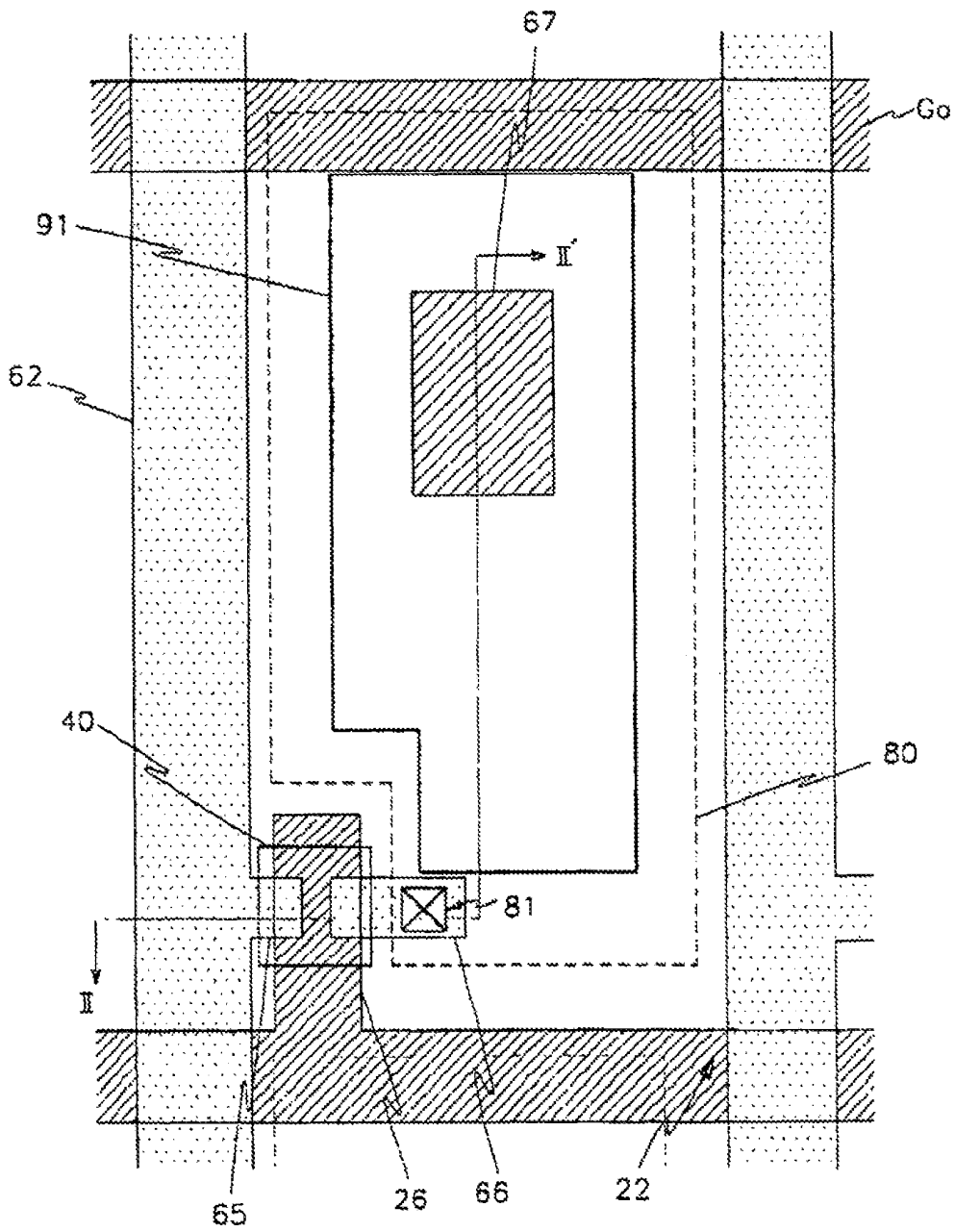

FIG. 2

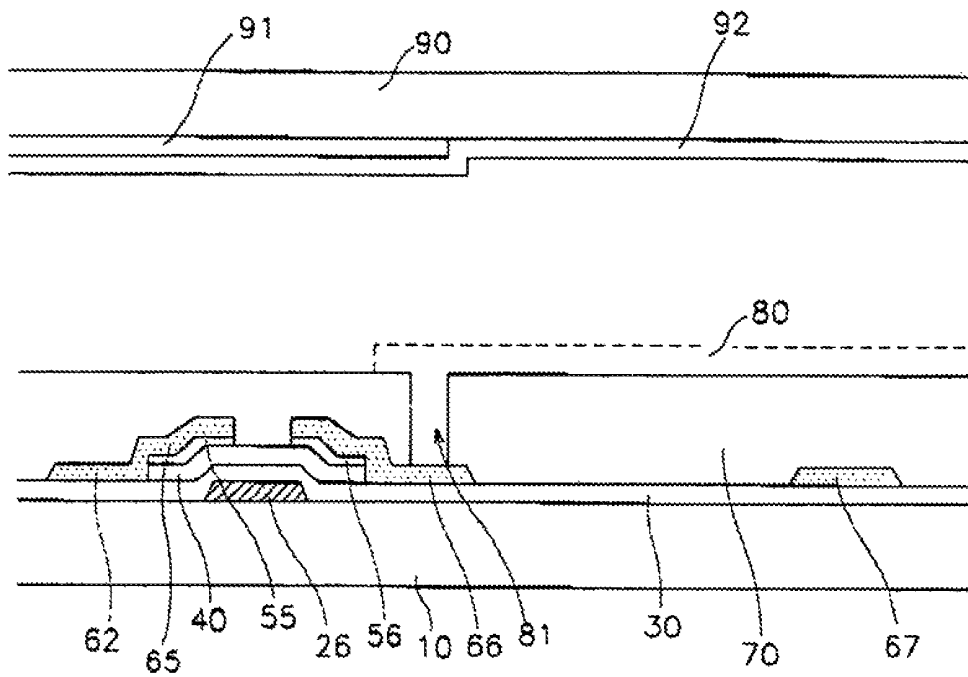

FIG. 4

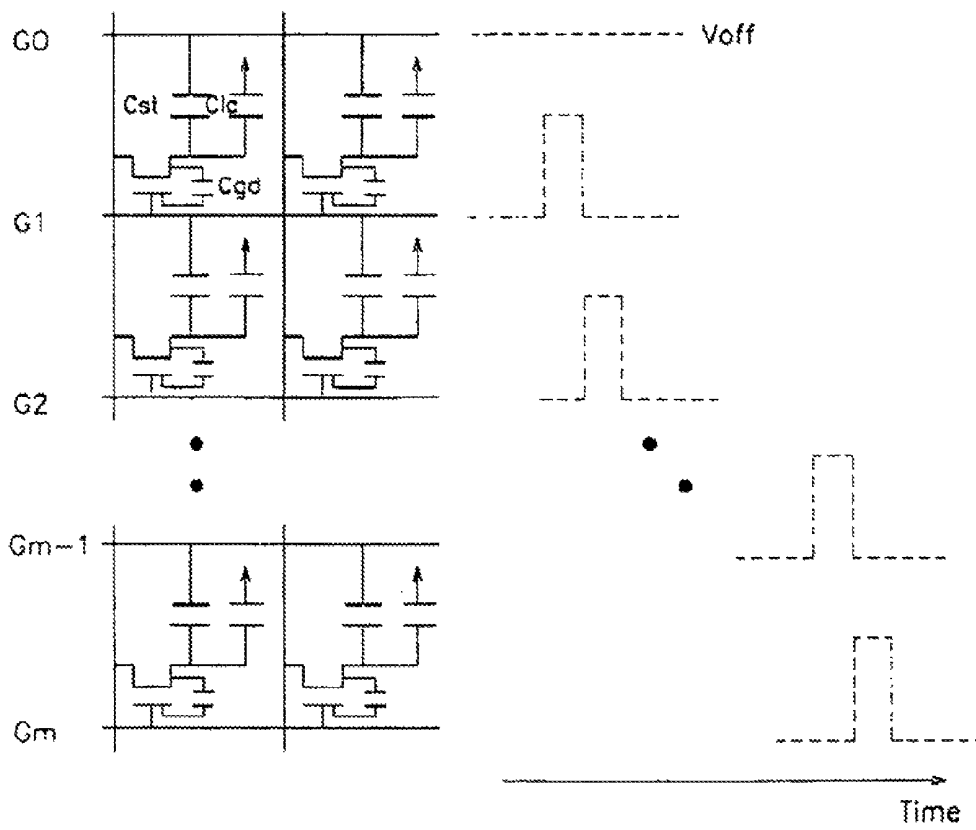

FIG. 5

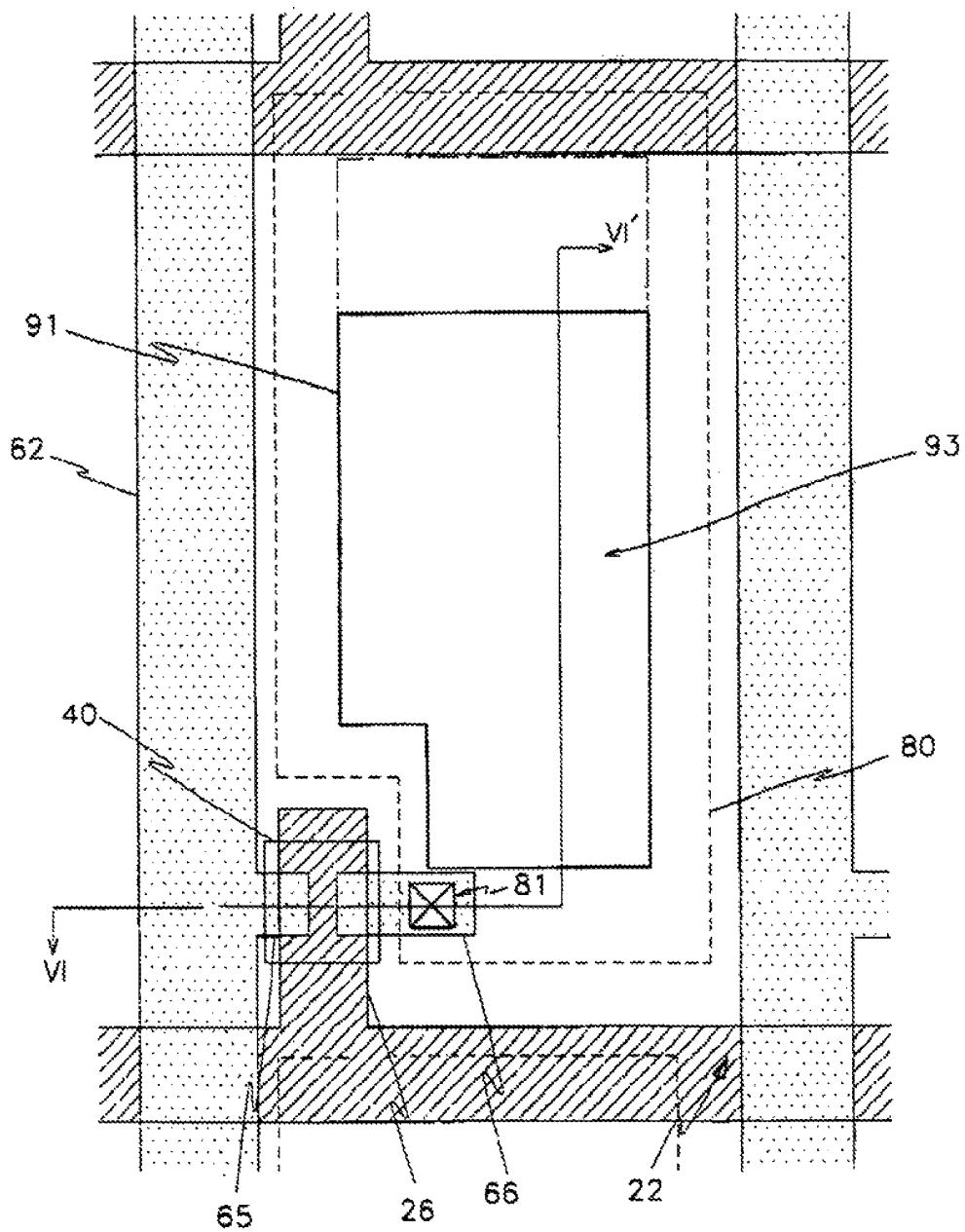

FIG. 6

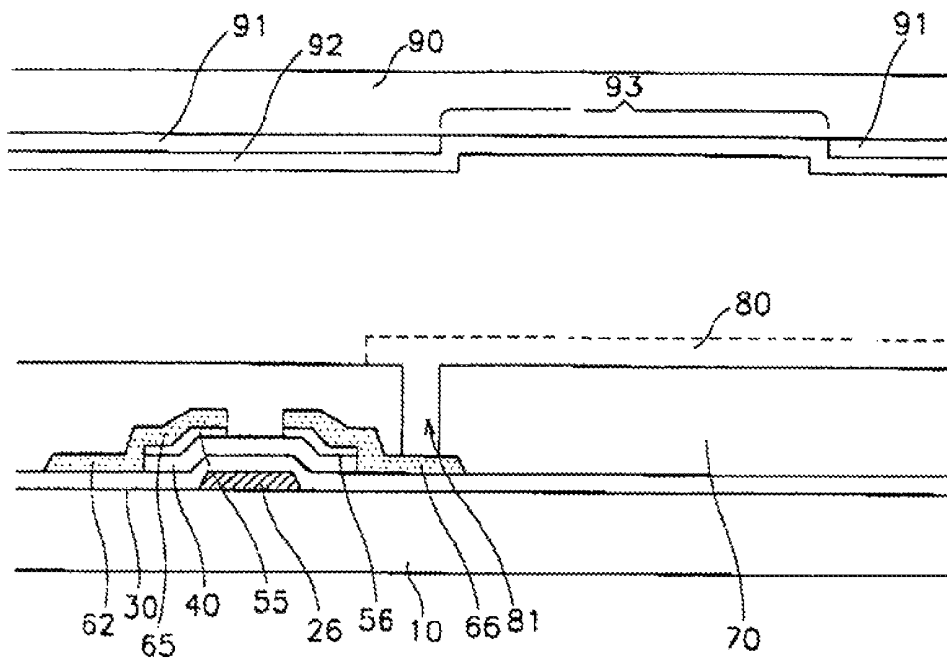

FIG. 7

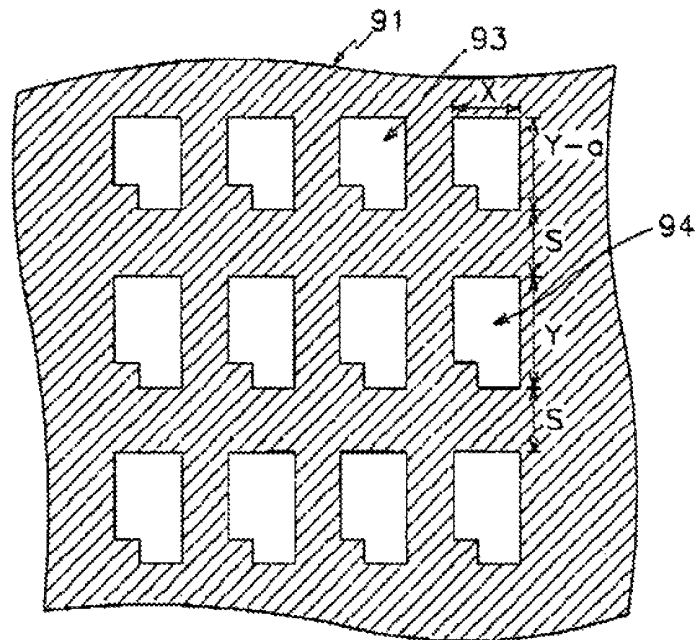

FIG. 8

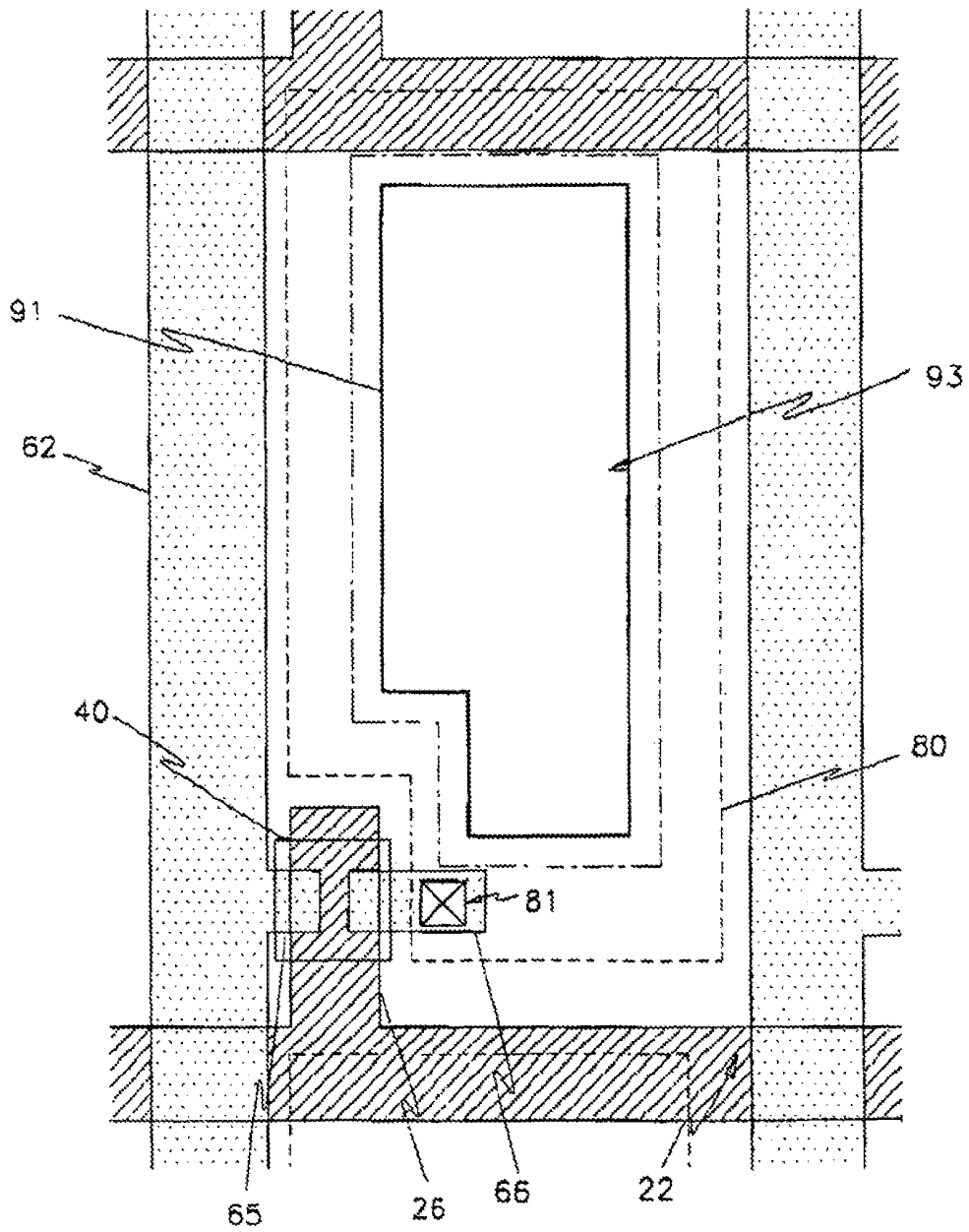

FIG. 9

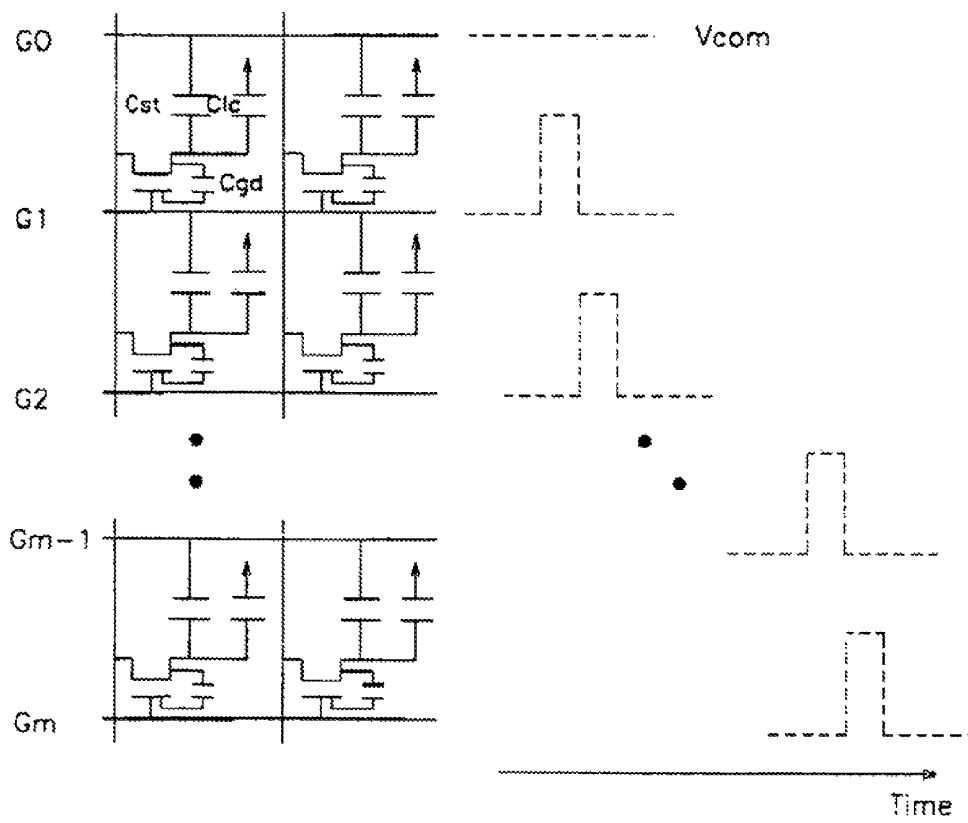

FIG. 11

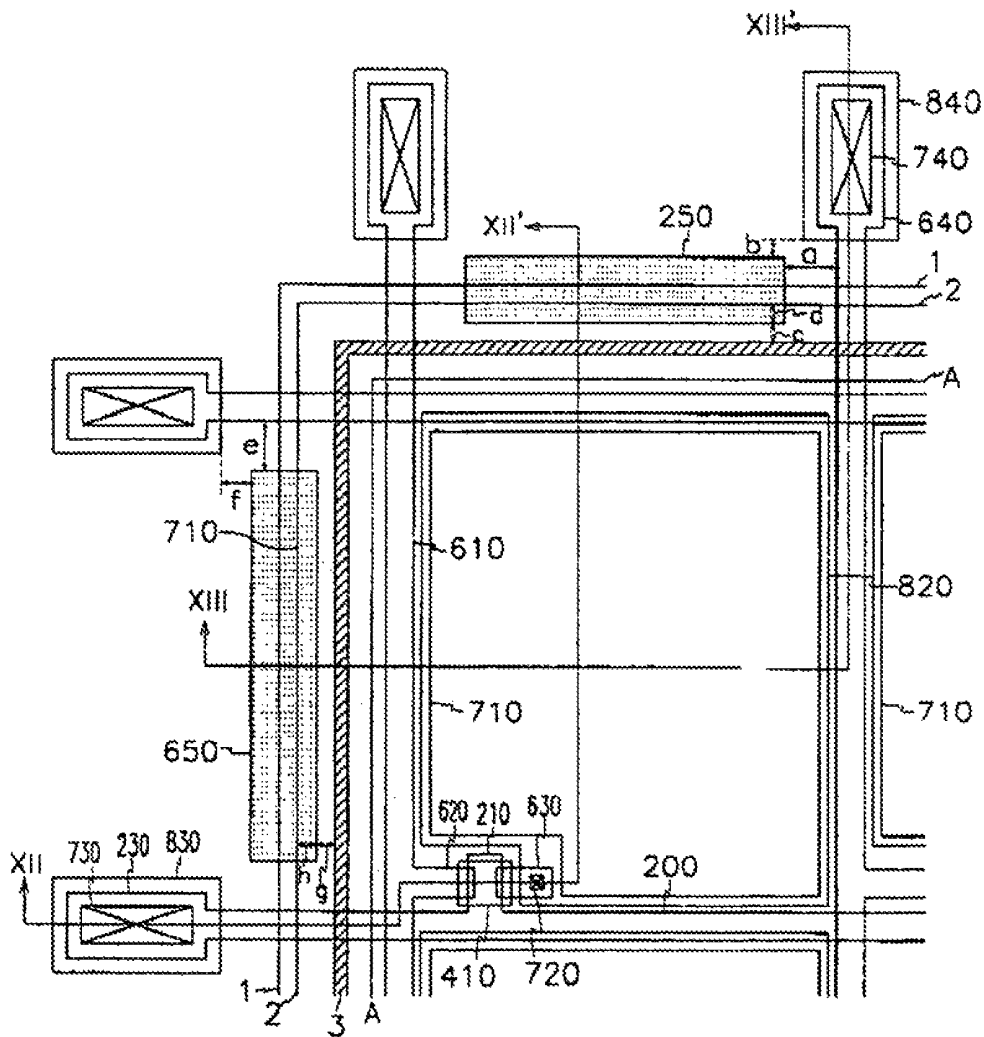

FIG. 13

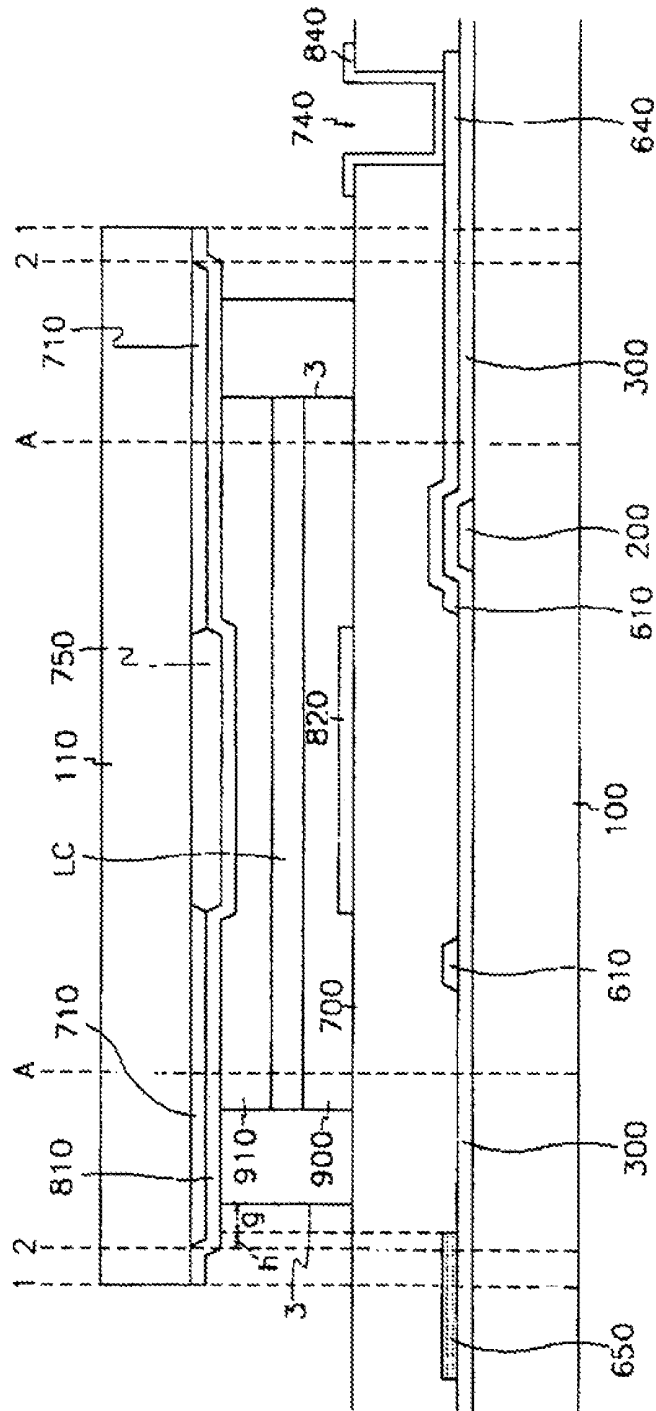

FIG. 14A

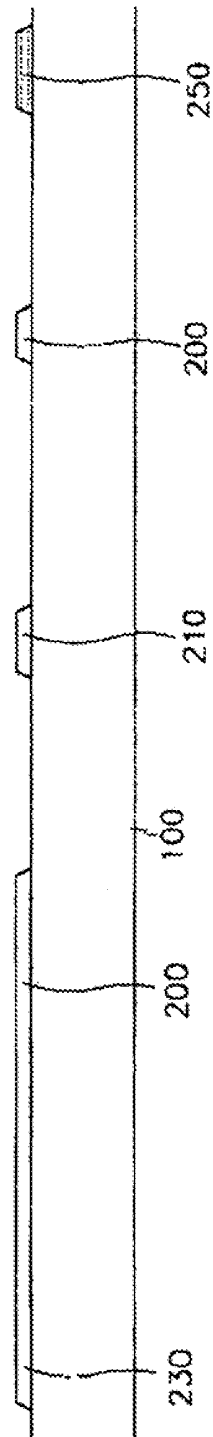

FIG. 14B

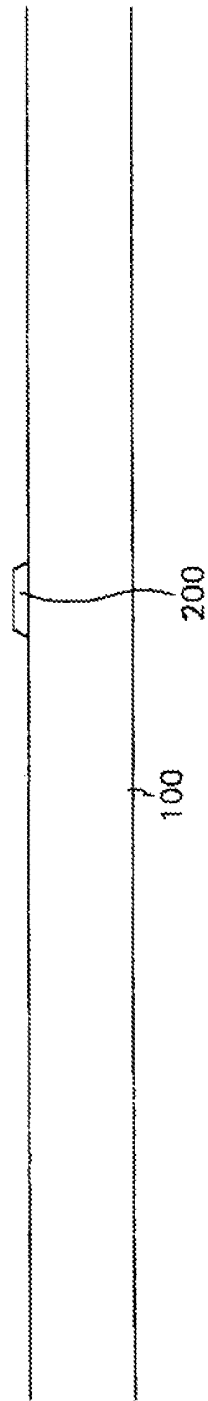

FIG. 15A

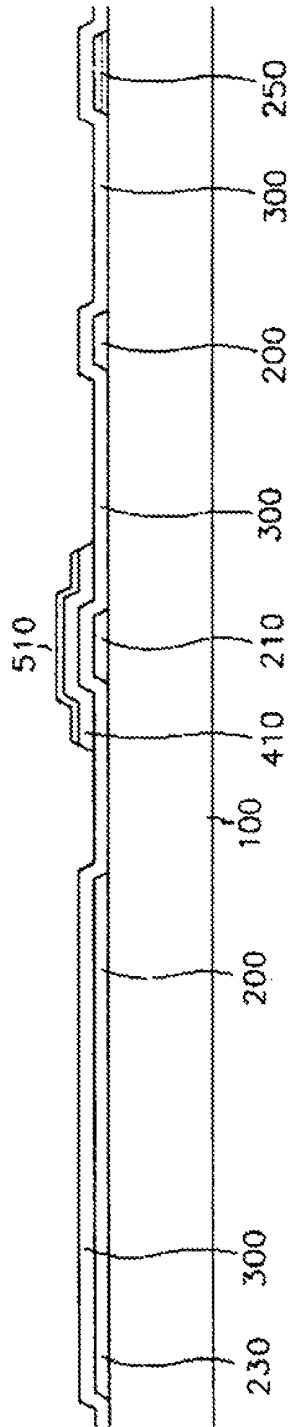

FIG. 15B

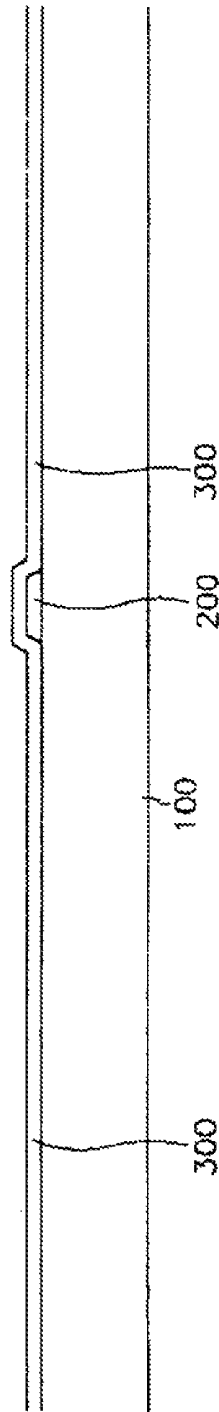

FIG. 16A

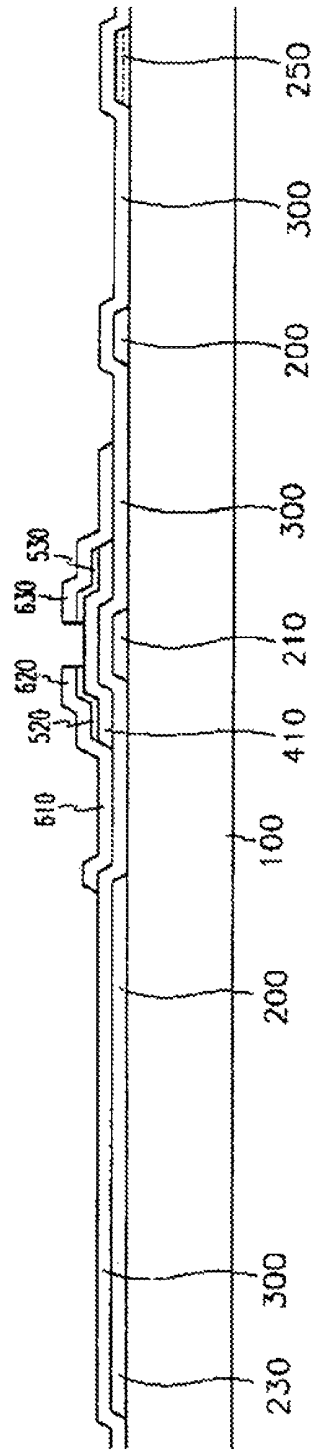

FIG. 16B

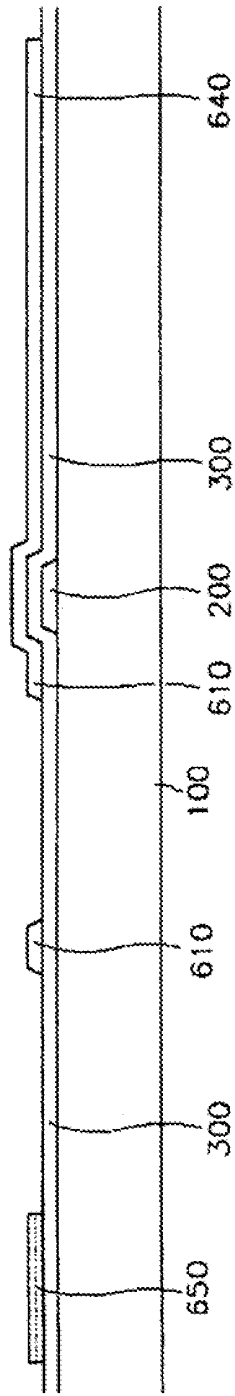

FIG. 17A

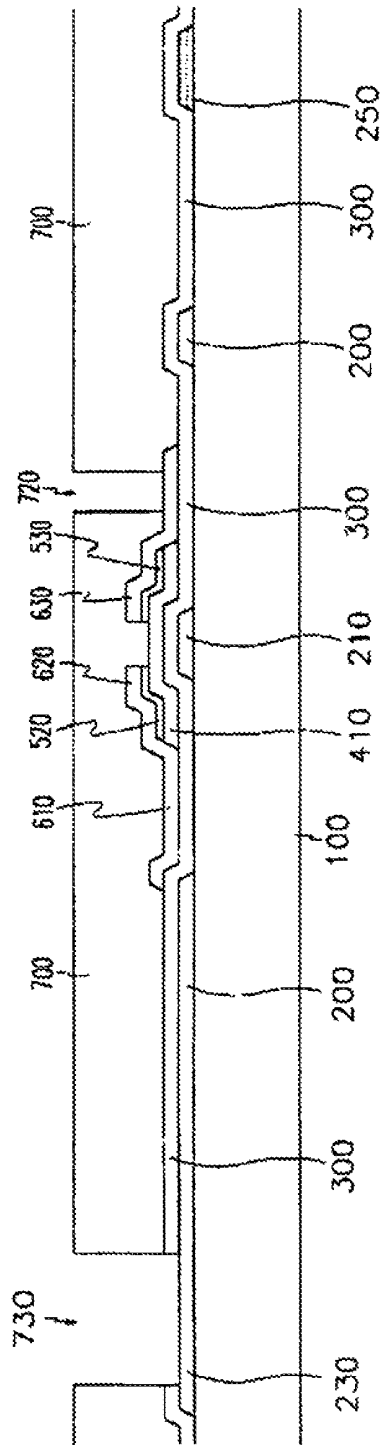

FIG. 17b

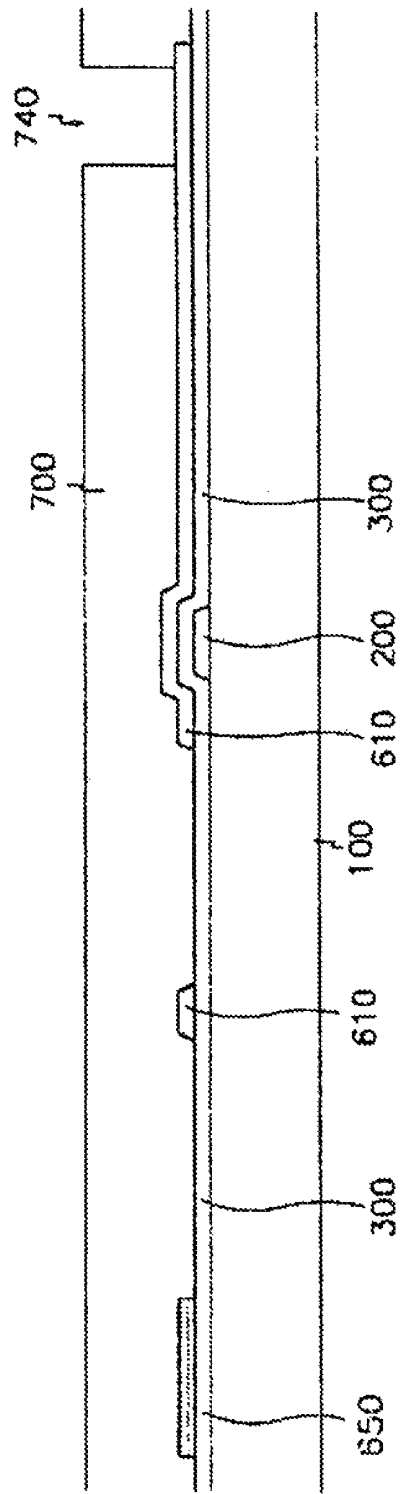
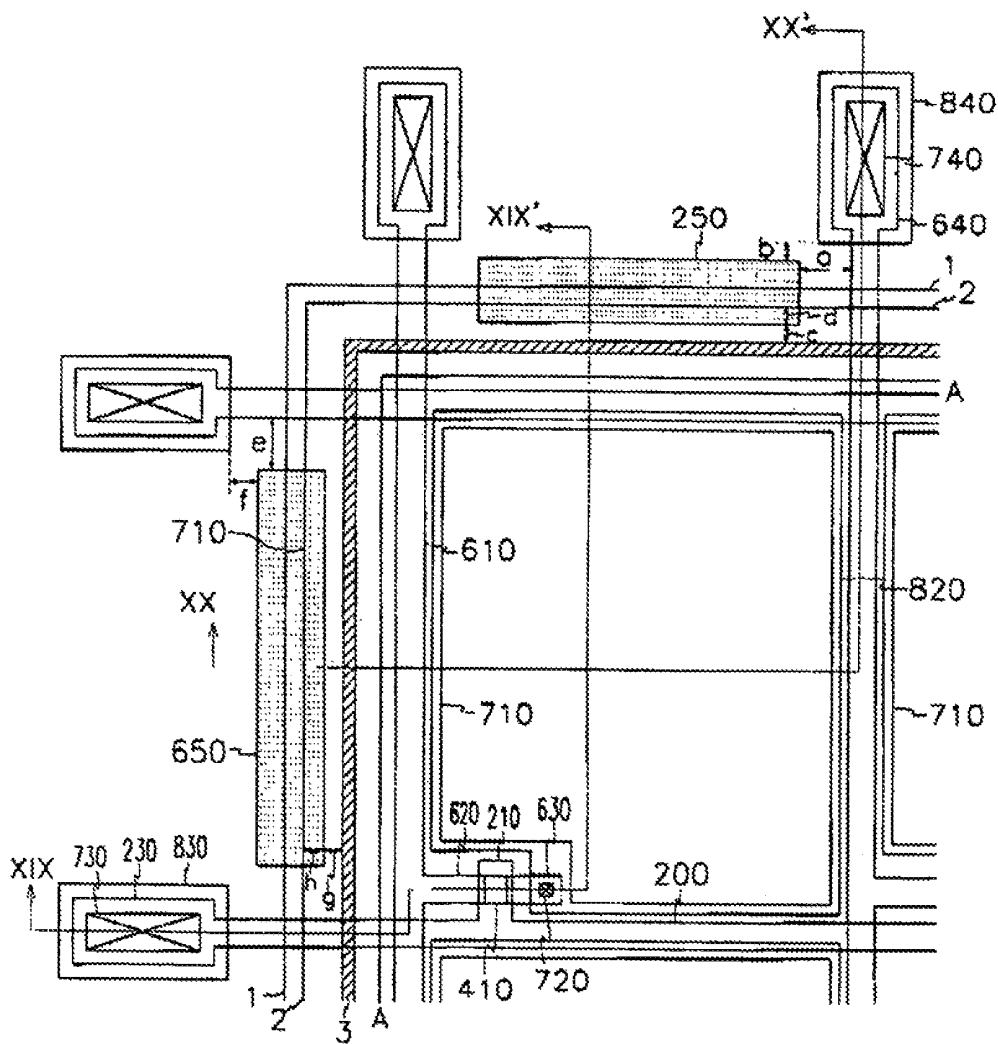

FIG. 18



LIQUID CRYSTAL DISPLAY

CROSS REFERENCE TO PRIOR APPLICATIONS

This application is a Divisional of U.S. patent application Ser. No. 12/244,099 filed Oct. 6, 2005, which is a Continuation Application of a U.S. patent application Ser. No. 09/615,794 filed Jul. 13, 2000, now abandoned which claims priority to and the benefit of Korean Patent Application Nos. 1999-28287 filed on Jul. 13, 1999; 1999-48841 filed on Nov. 5, 1999; and 1999-67761 filed Dec. 31, 1999, which are incorporated herein by reference in their entireties.

BACKGROUND OF THE INVENTION

(a) Field of the Invention

The present invention relates to a liquid crystal display and, more particularly, to a liquid crystal display which bears uniform brightness characteristic over the entire screen area without leakage of light.

(b) Description of the Related Art

Generally, a liquid crystal display has an upper substrate with a common electrode and color filters (usually called the "color filter substrate"), a lower substrate with thin film transistors and pixel electrodes (usually called the "TFT array substrate"), and a liquid crystal layer sandwiched between the color filter substrate and the TFT array substrate. Different electrical potentials are applied to the pixel electrodes and the common electrode while forming electric fields to change the liquid crystal molecule orientation. In this way, the light transmission is controlled to display picture images.

In such a liquid crystal display, with only a TFT attached to it, the charge applied to switch the liquid crystal leaks away in a brief time after a signal arrives. Therefore, it is necessary to connect an additional capacitor to the liquid crystal so that the liquid crystal is able to retain the charge associated with the first signal until a second signal is received.

For example, a capacitance may be conferred on a liquid crystal by using an adjacent gate electrode line.

Each pixel electrode overlaps over the previous gate line with an insulating layer interposed to form a storage capacitance C_{st} . The pixel electrode faces the common electrode with a liquid crystal layer interposed to form a liquid crystal capacitance C_{lc} . Furthermore, a parasitic capacitance C_{gd} is formed between a gate electrode and a drain electrode.

The voltage applied between each pixel electrode and the common electrode changes at 60 Hz (60 frames per second). Within one frame, pulses of V_{on} are applied to sequentially turn on TFTs from the first gate line to the last gate line. In case the V_{on} pulse is applied to a particular gate line, off-voltages V_{off} are applied to the other gate lines. When the voltage applied to the common electrode V_{com} is set to 5 V, the on-voltage V_{on} becomes to be about 20 V, and the off-voltage V_{off} to be about -7 V. When the on-voltage V_{on} is applied to a particular gate line, the TFTs positioned at that line are in an on-state, and the picture signal voltages applied to the data lines are transmitted to the pixel electrodes. In contrast, when the off-voltage V_{off} is applied to the TFTs at the particular gate line while applying V_{on} to the previous gate line, the electric potential V_g of the previous gate line is elevated by 27 V from -7 V to 20 V. At this time, the electric potential of the pixel electrode V_p is also increased. The amount of increased potential of the pixel electrode ΔV_p can be expressed by the following equation:

$$\Delta V_p = [C_{st} / (C_{st} + C_{lc} + C_{gd} + \text{other parasitic capacitance})] \times \Delta V_g (=27 \text{ V}).$$

At this time, the liquid crystal capacitance C_{lc} as a function of voltage difference between V_{com} and V_p as well as the parasitic capacitance C_{gd} are varied together. Thereafter, when the previous gate line is shifted from V_{on} to V_{off} , the electric potential of the pixel electrode V_p returns to the initial state, but not the liquid crystal capacitance C_{lc} and the parasitic capacitance C_{gd} due to voltage dependence thereof. As such a variation in electrical potentials of the pixel electrodes at the second to last gate lines are made in the same pattern, the pixel electrode portions at the second to last gate lines bears uniform brightness at the same gray scale. However, since the pixel electrodes at the first gate line have no previous gate line, the electrical potentials of those electrodes change in different manner and the brightness becomes different in the same gray scale. As the brightness at the first gate line portion is usually brighter compared to other gate line portions, the picture images displayed at that portion disturbs the human eye.

In order to solve such a problem, the technique of adding a storage capacitor line G_0 and connecting it to the second gate line G_2 or the last gate line G_m has been proposed. However, when the G_0 line is connected to the G_2 line, the integrated circuit (IC) for driving the G_2 line should be also employed for driving the G_0 line, resulting in shortage in driving current. Accordingly, the second gate line portion becomes much brighter than other gate line portions at a normally white mode. This phenomenon becomes serious as the electric load applied to each gate line becomes greater with the trend of high definition and increased screen size. In contrast, when the G_0 line is connected to the G_m line, complicated wiring via printed circuit boards (PCBs) should be made to interconnect the G_0 line and the G_m line, and the first and the last gate line portions differs in brightness from the other gate line portions.

In the meantime, the TFT array substrate usually has a size larger than the color filter substrate. In this connection, when assembled, the periphery of the TFT array substrate without the corresponding black matrix portion is exposed to the outside so that light leaks at the exposed portion.

SUMMARY OF THE INVENTION

It is an object of the present invention to provide a liquid crystal display which bears good picture quality with uniform brightness characteristic over the entire screen area.

It is another object of the present invention to provide a liquid crystal display which effectively prevents light leakage without generating short circuits.

These and other objects may be achieved by employing in a liquid crystal display light interception patterns. Alternatively, a liquid crystal display may have a black matrix with openings of different sizes depending on the pixel positions. A manufacturing method is also disclosed.

According to one aspect of the present invention, the liquid crystal display includes first and second insulating substrates facing to each other, and a liquid crystal injected into the gap between the first and second substrates. A plurality of gate lines is formed at the first substrate to transmit scanning signals, and data lines cross over the gate lines to transmit picture signals. Pixels are demarcated by the gate lines and the data lines. The gate lines demarcate the pixels into rows, and the data lines demarcate the pixels into columns. A black matrix defines each pixel, and a pixel electrode is formed at each pixel. A storage capacitor line is formed at the first substrate parallel to the gate line, and overlapped with the pixel electrodes at the first pixel row. Storage capacitors are formed between the pixel electrodes and the previous gate

lines as well as between the pixel electrodes and the storage capacitor line. A gate-off voltage or a common electrode voltage is applied to the storage capacitor line. Each pixel at the first pixel row with the storage capacitor formed between the corresponding pixel electrode and the storage capacitor line has an opening ratio different from that of the pixels at the other pixel rows. The opening ratio of the first pixel row is established to be 60-80% of the opening ratio of the other pixel rows.

The opening ratio is made different by forming a light interception pattern at each pixel of the first pixel row, or by changing opening volumes of the black matrix. The light interception pattern may be formed at the same layer as the data line or the gate line with the same material.

A gate-off line is formed at the first substrate to transmit a gate-off voltage, and the gate-off line and the storage capacitor line are formed at the same layer as the gate line. The gate-off line and the storage capacitor line are electrically connected to each other via a connection member, and the connection member is formed at the same layer as the data line or the pixel electrode.

In the above structure, uniform brightness over the entire screen area can be ensured.

According to another aspect of the present invention, the liquid crystal display includes a first insulating substrate, and a gate line assembly formed at the first insulating substrate. The gate line assembly has a plurality of gate lines, gate electrodes branched from the gate lines, and gate pads connected to the gate lines to transmit scanning signals thereto. First light interception patterns are isolated from the gate line assembly. A gate insulating layer covers the gate line assembly and the first light interception patterns. A semiconductor layer is formed on the gate insulating layer, and an ohmic contact layer is formed on the semiconductor layer. A data line assembly is formed on the semiconductor layer and the gate insulating layer. The data line assembly has a plurality of data lines crossing over the gate lines while forming pixel areas, source electrodes branched from the data lines, drain electrodes positioned opposite to the source electrodes while centering around the gate electrodes, and data pads connected to the data lines to transmit picture signals thereto. The pixel areas collectively forms a display area. Second light interception patterns are isolated from the data line assembly. A protective layer covers the data line assembly and the second light interception patterns while forming first to third contact holes exposing the gate pad, the data pad and the drain electrode, respectively. Pixel electrodes are connected to the drain electrodes via the third contact hole. A subsidiary gate pad covers each gate pad via the first contact hole, and a subsidiary data pads covers each data pad via the second contact hole.

A second insulating substrate faces the first substrate, and color filters are formed at the second substrate while corresponding to the pixel areas. A black matrix is formed at the second substrate while surrounding the color filters, and a common electrode covers the color filters and the black matrix. A sealer seals the first and second substrates together.

The first and second light interception patterns are positioned outside of the display area such that they are overlapped with the black matrix, but not with the gate and data lines, and the sealer.

In the above structure, possible light leakage can be prevented with the light interception patterns without generating short circuits.

BRIEF DESCRIPTION OF THE DRAWINGS

A more complete appreciation of the invention, and many of the advantages thereof, will be readily apparent as the same

becomes better understood by reference to the following detailed description when considered in conjunction with the accompanying drawings in which like reference symbols indicate the same or the similar components, wherein:

FIG. 1 is a plan view of a liquid crystal display according to a first preferred embodiment of the present invention;

FIG. 2 is a cross sectional view of the liquid crystal display taken along the II-II' line of FIG. 1;

FIG. 3 is another plan view of the liquid crystal display shown in FIG. 1 illustrating the wiring structure;

FIG. 4 is a circuit diagram of the liquid crystal display shown in FIG. 1;

FIG. 5 is a plan view of a liquid crystal display with a black matrix according to a second preferred embodiment of the present invention;

FIG. 6 is a cross sectional view of the liquid crystal display taken along the VI-VI' line of FIG. 5;

FIG. 7 is a plan view of the black matrix shown in FIG. 5;

FIG. 8 is a plan view of a liquid crystal display according to a third preferred embodiment of the present invention;

FIG. 9 is a circuit diagram of the liquid crystal display shown in FIG. 8;

FIG. 10 is a plan view of a liquid crystal display according to a fourth preferred embodiment of the present invention;

FIG. 11 is another plan view of the liquid crystal display shown in FIG. 10 illustrating the wiring structure;

FIG. 12 is a cross sectional view of the liquid crystal display taken along the XII-XII' line of FIG. 11;

FIG. 13 is a cross sectional view of the liquid crystal display taken along the XIII-XIII' line of FIG. 11;

FIGS. 14A to 17B are views sequentially illustrating the steps of processing the liquid crystal display shown in FIG. 10;

FIG. 18 is a plan view of a liquid crystal display according to a fifth preferred embodiment of the present invention;

FIG. 19 is a cross sectional view of the liquid crystal display taken along the XIX-XIX' line of FIG. 18; and

FIG. 20 is a cross sectional view of the liquid crystal display taken along the XX-XX' line of FIG. 18.

DETAILED DESCRIPTION OF THE PREFERRED EMBODIMENTS

Preferred embodiments of this invention will be explained with reference to the accompanying drawings.

FIG. 1 is a plan view of a liquid crystal display according to a first preferred embodiment of the present invention where one pixel area of the first pixel row is illustrated, and FIG. 2 is a cross sectional view of the liquid crystal display taken along the II-II' line of FIG. 2. The liquid crystal display according to the present invention has a basic structure where a liquid crystal layer is sandwiched between upper and lower substrates with a plurality of pixel areas at different pixel rows, and the following description will be made with respect to one pixel area at the first pixel row.

As shown in the drawings, the lower substrate 10 is overlaid with a first gate line 22 proceeding in the horizontal direction, a gate electrode 26 branched perpendicularly from the first gate line 22 and a storage capacitor line G0 proceeding parallel to the first gate line 22. A gate insulating layer 30 is formed on the gate line 22, the gate electrode 26, and the storage capacitor line G0. A semiconductor layer 40 is formed on the gate insulating layer 30 over the gate electrode 26, and a data line 62 is formed on the gate insulating layer 30 while crossing perpendicularly over the first gate line 22 and the storage capacitor line G0. A source electrode 65 is branched perpendicularly from the data line 62. A drain electrode 66 is

positioned at the same plane as the source electrode **65** opposite thereto while centering around the gate electrode **26**. The source and drain electrodes **65** and **66** are placed over the semiconductor layer **40** by interposing ohmic contact layers **55** and **56**.

Of course, the storage capacitor line **G0** may be referred to as the first gate line if it functions as an electrode part of a storage capacitor for the first pixel row.

A light interception pattern **67** is centrally formed at the pixel area with the same plane as the data line **62**, the source electrode **65** and the drain electrode **66**. A protective layer **70** is formed on the data line **62**, the source electrode **65** and the drain electrode **66** with a contact hole **81** exposing the drain electrode **66**. A pixel electrode **80** is formed on the protective layer **70**, and connected to the drain electrode **66** via the contact hole **81**. The pixel electrode **80** is formed with a transparent material such as indium tin oxide (ITO), and partially overlapped with the storage capacitor line **G0**. Each pixel area is demarcated by the two data lines **62** crossing over the neighboring two gate lines, and the pixel electrode **80** covers the entire pixel area.

A black matrix **91** and color filters (not shown) are formed on the upper substrate **90** such that they face the lower substrate **10**. The black matrix **91** is formed of opaque material that can prevent light leakage. It also defines each pixel area. A common electrode **92** is formed on the black matrix **91** and the color filters. It covers the entire upper substrate **90**. Alternatively, the black matrix **91** and the color filters may be formed at the lower substrate **10**.

In the above pixel structure, the pixel electrodes **80** at the first pixel row overlap the storage capacitor line **G0** to form a desired storage capacitance. On the other hand, the pixel electrodes **80** of the second to the last pixel rows overlap the previous corresponding gate lines **22** respectively.

The first pixel row has an opening ratio lower than that of the other pixel rows due to the presence of the light interception patterns **67**.

The light interception pattern **67** may be formed either at the same layer as the data line **62**, the source electrode **65** and the drain electrode **66**, or at the same layer as the gate line **22** and the gate electrode **26**.

As shown in FIG. **3**, when the lower substrate **10** is combined with the upper substrate **90**, the periphery of the lower substrate **10** is exposed to the outside because it is larger than the upper substrate **90**. Gate signal transmission films **28** are arranged at the exposed portion of the lower substrate **10** in the longitudinal direction of the data lines **62**. Each gate signal transmission film **28** is provided with a gate driving integrated circuit **27**. The gate driving integrated circuit **27** is electrically connected to the gate lines **22**, and outputs gate driving signals. Data signal transmission films **68** are arranged at the exposed portion of the lower substrate **10** in the longitudinal direction of the gate lines **22**. Each data signal transmission film **68** is provided with a data driving integrated circuit **67**. The data driving integrated circuit **67** is electrically connected to the data lines **62**, and outputs data driving signals. Furthermore, a printed circuit board **12** for driving the liquid crystal display is connected to the data signal transmissions **68**.

Meanwhile, a common electrode wire **71** for applying the common electrode voltage V_{com} to the common electrode **92**, a gate-on wire **72** for applying the on-voltage V_{on} to the TFTs, and a gate-off wire for applying the off-voltage V_{off} to the TFTs are formed on the edge portion of the lower substrate **10** between the gate signal transmission film **28** and the data signal transmission film **68**. Additional wires for transmitting carry-in or gate-clock signals may be further provided.

As shown in FIGS. **3** and **4**, the storage capacitor line **G0** at the first pixel row is connected to the gate-off wire **73** via a connection member such that the gate-off voltage V_{off} is transmitted thereto. It is preferable that the common electrode wire **71**, the gate-on wire **72** and the gate-off wire **73** are formed at the same layer as the storage capacitor line **G0** and the gate lines **22** with the same material. The connection member **77** is formed at the same layer as the data lines **62** or the pixel electrodes **80** with the same material. The protective layer **70** or the gate insulating layer **30** has a contact hole that receives the connection member **77**.

Because the substrate **10** has the wires **71** to **73** that transmit appropriate signals to the gate driving integrated circuit **27**, a connector that interconnects a gate printed circuit board and a data printed circuit board may be eliminated. Furthermore, as in this preferred embodiment, only the data printed circuit board may be used without the gate printed circuit board.

The gate driving integrated circuit **27** and the data driving integrated circuit **67** may be directly mounted onto the lower substrate **10**.

As described above, the opening ratio of the first pixel row is lower to compensate a possible increase in brightness at the first pixel row when applying the off-voltage V_{off} to the storage capacitor line **G0**. Furthermore, even though slight darkness is present at the first pixel row portion due to the presence of the light interception patterns **67**, it is not unpleasant to the eye, producing good picture quality.

It turns out that the optimal opening ratio of the first pixel row lies in the range of 60-80% of the other pixel rows. Of course, such a value may be slightly different depending upon the factors such as light transmission, Clc , or Cst .

In this way, the resulting liquid crystal display can bear good picture quality by compensating brightness differences with a simplified wiring structure.

Alternatively, in order to reduce the opening ratio of the first pixel row, the opening portions of the black matrix **91** at the first pixel row may be reduced to be smaller than those of the black matrix **91** at the other pixel rows.

FIG. **5** is a plan view of a liquid crystal display according to a second preferred embodiment of the present invention where one pixel area at the first pixel row is illustrated, and FIG. **6** is a cross sectional view of the liquid crystal display taken along the VI-VI' line of FIG. **5**. In this preferred embodiment, other components and structures of the liquid crystal display are the same as those related to the first preferred embodiment except that the first pixel row's opening portions of the black matrix **91** are different in lengths from the other pixel rows and that the light interception patterns **67** is eliminated.

As shown in FIG. **7**, the opening portions **93** of the black matrix **91** at the first pixel row are designed to have a smaller length than the opening portions **94** at the other pixel rows to reduce the opening ratio of the first pixel row. That is, the opening portions **94** of the black matrix **91** at the second to last pixel rows have a width X and a length Y while being spaced apart from each other with a distance S on the row by row basis. However, the opening portions **93** of the black matrix **91** at the first pixel row have a length $Y-a$ to be 60 to 80% of the length Y of the other opening portions **94**.

The structure where only the length of the opening portions **93** of the black matrix **91** at the first pixel row becomes decreased with a uniform width can produce better picture images. Of course, it is possible that the width and length of the opening portions **93** of the black matrix **91** at the first pixel row are all decreased to reduce the opening ratio at those portions.

FIGS. 8 and 9 illustrate a liquid crystal display according to a third preferred embodiment of the present invention. In this preferred embodiment, other components and structures of the liquid crystal display are the same as those related to the second preferred embodiment except that the common electrode voltage V_{com} is applied to the storage capacitor electrode G_0 at the first pixel row, and the opening width and length of the black matrix 91 at the first pixel row are all designed to be shorter than those of the black matrix 91 at the other pixel rows.

FIG. 10 is a plan view of a liquid crystal display according to a fourth preferred embodiment of the present invention where a TFT array substrate 100 and a color filter substrate 110 are assembled via a sealer 3 . Since the TFT array substrate 100 is larger than the color filter substrate 110 , it is partially exposed to the outside.

As shown in FIG. 10, a plurality of gate lines 200 are formed at the TFT array substrate 100 in the horizontal direction, and gate pads 230 are connected to the end portions of the gate lines 200 . A plurality of data lines 610 are formed at the TFT array substrate 100 in the vertical direction, and data pads 640 are connected to the end portions of the data lines 610 .

A plurality of pixel areas P are existent at the TFT array substrate 100 . Each pixel area P is defined by the two data lines 610 crossing over the neighboring gate lines 200 , and a display area A can be indicated by the sum of the pixel areas P . A sealer 3 externally surrounds the display area A .

Color filters CF are formed at the color filter substrate 110 such that each color filter CF faces the corresponding pixel area of the TFT array substrate 100 . A black matrix BM surrounds the color filters CF such that it can prevent light leakage at the region between the neighboring pixel areas. As indicated in FIG. 10 with the solid line 2 , the peripheral portion of the black matrix BM is placed inside the peripheral portion of the color filter substrate 110 while being positioned outside the sealer 3 .

In the above structure, lights tend to leak at the region B between the gate and data pads 230 and 640 and the black matrix BM . In order to prevent such a light leakage, light interception patterns 250 and 650 are formed at that region B such that they do not overlap the gate and data lines 200 and 610 , and the gate and data pads 230 and 640 . Furthermore, the light interception patterns 230 and 640 should not be overlapped with the sealer 3 , but may be overlapped with the black matrix BM .

Alternatively, the color filters CF and the black matrix BM may be formed at the TFT array substrate 100 .

FIG. 11 is an amplified view of the C portion of the liquid crystal display shown in of FIG. 10. FIG. 12 is a cross sectional view of the liquid crystal display taken along the XII-XII' line of FIG. 11. FIG. 13 is a cross sectional view of the liquid crystal display taken along the XIII-XIII' line of FIG. 11.

As shown in the drawings, the TFT array substrate 100 is overlaid with a gate line assembly, and first light interception patterns 250 . The gate line assembly includes a plurality of gate lines 200 , gate electrodes 210 branched from the gate lines 200 , and gate pads 230 connected to the end portions of the gate lines 200 to receive scanning signals from the outside and transmit them to the gate lines 200 . The gate line assembly and the first light interception patterns 250 are placed on the same plane, and formed together with a conductive metallic material such as aluminum (Al), aluminum alloy, molybdenum (Mo), molybdenum-tungsten alloy (MoW), chrome (Cr), and tantalum (Ta).

The gate line assembly and the first light interception patterns 250 may be formed either with a single layer or with double or more layers. In the case of the double-layered structure, it is preferable that one layer is formed with a material having a low resistance while the other layer being formed with a material having a good contact characteristic. For instance, two layers based on chrome and aluminum or based on aluminum and molybdenum may be provided for the double-layered structure.

The gate line assembly and the first light interception patterns 250 are covered by a gate insulating layer 300 . The gate insulating layer 300 may be formed with silicon nitride.

A semiconductor layer 410 is formed on the gate insulating layer 300 , and two separate ohmic contact layers 520 and 530 are formed on the semiconductor layer 410 while centering around the gate electrode 210 . The semiconductor layer 410 may be formed with amorphous silicon, and the ohmic contact layers 520 and 530 with amorphous silicon into which n-type impurities such as phosphorus (P) are doped.

A data line assembly and second light interception patterns 650 are formed on the ohmic contact layers 520 and 530 and the gate insulating layer 300 . The data line assembly includes a plurality of data lines 610 , source electrodes 620 branched from the data lines 610 , drain electrodes 630 positioned opposite to the source electrodes 620 while centering around the gate electrode 210 , and data pads 640 connected to the end portions of the data lines 610 to receive picture signals from the outside and transmit them to the data lines 610 . The data line assembly and the second light interception patterns 650 are placed on the same plane, and formed together with a conductive metallic material such as aluminum (Al), aluminum alloy, molybdenum (Mo), molybdenum-tungsten alloy (MoW), chrome (Cr), and tantalum (Ta).

As in the gate line assembly and the first light interception patterns 250 , the data line assembly and the second light interception patterns 650 may be formed either with a single layer or with double or more layers.

The second light interception patterns 650 are positioned at the region between the gate pads 230 and the display area A as well as between the neighboring gate lines 200 such that they are not overlapped with the gate lines 200 and the gate pads 230 . Likewise, the first light interception patterns 250 are positioned at the region between the data pads 640 and the display area A as well as between the neighboring data lines 610 such that they are not overlapped with the data lines 610 and the data pads 640 .

A protective layer 700 is formed on the data line assembly, the second light interception patterns 650 , the semiconductor layer 410 , and the gate insulating layer 300 . The protective layer 700 may be formed with silicon nitride. The protective layer 700 has a contact hole 730 exposing the gate pad 230 together with the gate insulating layer 300 , a contact hole 740 exposing the data pad 640 , and a contact hole 720 exposing the drain electrode 630 .

Pixel electrodes 820 , subsidiary gate pads 830 , and subsidiary data pads 840 are formed on the protective layer 700 with a transparent material such as indium tin oxide (ITO).

Each pixel electrode 820 is connected to the drain electrode 630 via the contact hole 720 . The subsidiary gate pad 830 and the subsidiary data pad 840 are connected to the gate pad 230 and the data pad 640 via the contact holes 730 and 740 , respectively. The subsidiary gate and data pads 830 and 840 are provided to enhance adhesion between the gate and data pads 230 and 640 and the external circuits, and to protect the gate and data pads 230 and 640 .

An alignment layer 900 is formed on the protective layer 700 and the pixel electrodes 820 . In order to align the liquid

crystal molecules, the alignment layer **900** may be surface-treated through rubbing or light illumination.

In the meantime, the color filter substrate **110** is overlaid with a black matrix **710**, and color filters **750** surrounded by the black matrix **710**.

An ITO-based common electrode **810** is formed on the black matrix **710** and the color filters **750**, and an alignment layer **910** is formed on the common electrode **810**.

The TFT array substrate is assembled with the color filter substrate **110** via a sealer **3**, and a liquid crystal LC is injected into the gap between the substrates.

As shown in FIGS. **10** to **13**, the borderline of the color filter substrate **110** is indicated by the reference numeral **1**, and the borderline of the black matrix **710** indicated by the reference numeral **2**. The sealer **3** is positioned outside of the display area A, and the borderline **2** of black matrix **710** is disposed between the borderline **1** of the color filter substrate **110** and the sealer **3**.

In view of alignment errors, the first light interception patterns **250** are spaced apart from the data lines **610** by a minimum distance a, and the second light interception patterns **650** are spaced apart from the gate lines **200** by a minimum distance e. Furthermore, the first light interception patterns **250** are spaced apart from the data pads **640** by a reasonable distance b such that they are not overlapped with the data pads **640** as well as TCPs attached thereto in a reliable manner, and the second light interception patterns **650** are spaced apart from the gate pads **230** by a distance f. In addition, the first light interception patterns **250** are spaced apart from the sealer **3** by a distance c, and the second light interception patterns **650** are spaced apart from the sealer **3** by a distance g. As it is desirable that the first and second light interception patterns **250** and **650** do not have a gap with the black matrix **710**, they are overlapped with the black matrix **710** by a span d and h in view of the alignment errors.

In case the first and second light interception patterns **250** and **650** are overlapped with the gate and data lines **200** and **610**, short circuit may occur between them. Furthermore, in case the first and second light interception patterns **250** and **650** are overlapped with the sealer **3**, short circuit may also occur between them when the sealer **3** is compressed for the sealing purpose. In the above structure, even though a small gap exists between the light interception patterns **250** and **650** and the gate and data lines **200** and **610**, only negligible amount of light may leak there.

Such light interception patterns **250** and **650** may be also applied to in-plane switching (IPS) type liquid crystal displays where the common electrode and the pixel electrodes are formed at the TFT array substrate, and super twisted nematic (STN) liquid crystal displays where stripe-shaped electrodes cross over at the two substrates without TFTs.

FIGS. **14A** to **17B** sequentially illustrate the steps of processing the TFT array substrate on a layer by layer base.

As shown in FIGS. **14A** and **14B**, a gate line assembly **200**, **210** and **230**, and first light interception patterns **250** are formed on an insulating substrate **100** through deposition and a first photolithography process.

Thereafter, as shown in FIGS. **15A** and **15B**, a gate insulating layer **300**, a semiconductor layer **410** and an ohmic contact layer **510** are sequentially deposited onto the substrate **100**, and the ohmic contact layer **510** and the semiconductor layer **410** are patterned through a second photolithography process.

As shown in FIGS. **16A** and **16B**, a data line assembly **610**, **620**, **630** and **640**, and second light interception patterns **650** are formed through deposition and a third photolithography process. Thereafter, the portion of the ohmic contact layer

510 exposed between the source electrode **620** and the drain electrode **630** is removed such that the ohmic contact layer **510** is separated into two portions **520** and **530** to expose the semiconductor layer **410**.

As shown in FIGS. **17A** and **17B**, a protective layer **700** is deposited onto the substrate **100**, and patterned through a fourth photolithography to form contact holes **720**, **730** and **740**.

Then, as shown in FIGS. **12** and **13**, pixel electrodes **820**, subsidiary gate pads **830**, and subsidiary data pads **840** are formed at the substrate **100** through deposition and a fifth photolithography process. Thereafter, an alignment layer **900** is formed at the substrate **100**.

The TFT array substrate **100** is then assembled with the color filter substrate **110** via a sealer **3**, and a liquid crystal LC is injected into the gap between the substrates **100** and **110** to complete a liquid crystal panel. In case the alignment layer **900** of the TFT array substrate **100** overlaps the sealer **3**, the overlapped portion of the alignment layer **900** is set to be $\frac{1}{2}$ of the width of the sealer **3**.

Thereafter, semiconductor circuits are mounted onto the liquid crystal panel.

First, an anisotropic conductive film (not shown) is formed at the exposed portion of the TFT array substrate **100** while covering the subsidiary gate and data pads **830** and **840**, and TCPs with semiconductor circuits are arranged at the TFT array substrate **100**, and thermal-compressed. In this case, the subsidiary pads **830** and **840** are electrically communicated with the TCPs via conductive balls contained in the anisotropic conductive film. This distance of b and f between the light interception patterns **250** and **650** and the pads **230** and **640** prevents possible short circuit via the conductive balls between the light interception patterns **250** and **650** and the subsidiary pads **830** and **840** during the thermal-compression.

FIGS. **18** to **20** illustrate a liquid crystal display according to a fifth preferred embodiment of the present invention. In this preferred embodiment, other components and structures of the liquid crystal display are the same as those related to the fourth preferred embodiment except that ohmic contact layers **520**, **530** and **550** and semiconductor layers **410** and **450** are positioned under a data line assembly **610**, **620**, **630** and **640**, and second light interception patterns **650**. The shape of the ohmic contact layers **520**, **530** and **550** is the same as that of the data line assembly **610**, **620**, **630** and **640** and the second light interception patterns **650**. The shape of the semiconductor layers **410** and **450** is the same as that of the data line assembly **610**, **620**, **630** and **640** and the second light interception patterns **650** except the portions between the source electrodes **620** and the drain electrodes **630**.

The fabrication process for the TFT array substrate is based on the four-mask photolithography.

First, a gate line assembly **200**, **210** and **230** and first light interception patterns **250** are formed on an insulating substrate **100** through deposition and a first photolithography process. Thereafter, a gate insulating layer **300** is deposited onto the gate line assembly **200**, **210** and **230** and the first light interception patterns **250** while covering them. Semiconductor layers **410** and **450**, ohmic contact layers **520**, **530** and **550**, and a data line assembly **610**, **620**, **630** and **640** are sequentially deposited, and patterned through a second photolithography process. A protective layer **700** is deposited onto the substrate **100**, and patterned through a third photolithography process to thereby form contact holes **720**, **730** and **740**. Thereafter, pixel electrodes **820**, subsidiary gate pads **830** and subsidiary data pads **840** are formed at the

substrate **100** through deposition and a fourth photolithography process. Finally, an alignment layer is formed at the substrate **100**.

In the second photolithography process, a photoresist film is deposited onto the conductive layer for the data line assembly, and patterned through a mask differentiated in light transmission. The exposed portion of the conductive layer is removed while exposing the underlying ohmic contact layer. The exposed portion of the ohmic contact layer and the underlying semiconductor layer are etched, and the portion of the conductive layer between the source and drain electrodes **620** and **630** is removed. Thereafter, the exposed portion of the conductive layer between the source and drain electrodes **620** and **630** and the underlying ohmic contact layer are etched together. In this way, the semiconductor layers **410** and **450**, the ohmic contact layers **520**, **530** and **550**, the data line assembly **610**, **620**, **630** and **640**, and the second light interception patterns **650** are formed at the substrate **100**.

In the resulting liquid crystal display, light interception patterns are provided at the TFT array substrate, and spaced apart from the electrode components of lines, pads, and a sealer so that leakage of light and short circuit can be effectively prevented.

While the present invention has been described in detail with reference to the preferred embodiments, those skilled in the art will appreciate that various modifications and substitutions can be made thereto without departing from the spirit and scope of the present invention as set forth in the appended claims.

What is claimed is:

1. A liquid crystal display (LCD), comprising:

- a first substrate;
- a second substrate facing the first substrate; and
- a plurality of pixels comprising a plurality of rows and a plurality of columns and divided into a first pixel group comprising only the pixels on a first row and a second pixel group comprising each of the remaining pixels on second to last rows,

wherein the pixels of the first pixel group have a first opening ratio, and the pixels of the second pixel group have a second opening ratio different from the first opening ratio;

wherein the first opening ratio is smaller than the second opening ratio;

wherein the first opening ratio is about 60% to about 80% of the second opening ratio; and

wherein the pixels of the first pixel group but not the pixels of the second pixel group have a light interception pattern in an opening portion.

2. The LCD of claim 1, further comprising a gate line and a data line, wherein the light interception pattern and at least one of the gate line and the data line is placed on the same plane.

3. A liquid crystal display (LCD), comprising:

- a first substrate;
- a second substrate facing the first substrate; and
- a plurality of pixels comprising a plurality of rows and a plurality of columns and divided into a first pixel group comprising only the pixels on a first row and a second pixel group comprising each of the remaining pixels on second to last rows,

wherein the pixels of the first pixel group have a first opening ratio, and the pixels of the second pixel group have a second opening ratio different from the first opening ratio;

wherein the first opening ratio is smaller than the second opening ratio; and

wherein the pixels of the first pixel group but not the pixels of the second pixel group have a light interception pattern in an opening portion.

4. The LCD of claim 3, further comprising a gate line and a data line, wherein the light interception pattern and at least one of the gate line and the data line is placed on the same plane.

* * * * *

专利名称(译)	液晶显示器		
公开(公告)号	US8432514	公开(公告)日	2013-04-30
申请号	US13/193508	申请日	2011-07-28
[标]申请(专利权)人(译)	金东GYU		
申请(专利权)人(译)	金东GYU		
当前申请(专利权)人(译)	三星DISPLAY CO. , LTD.		
[标]发明人	KIM DONG GYU		
发明人	KIM, DONG-GYU		
IPC分类号	G02F1/1333 G02F1/136 G02F1/00 G02F1/1335 G02F1/1362 G02F1/1368 G09F9/00 G09F9/30		
CPC分类号	G02F1/133512 G02F1/136209 G02F2001/136218 G02F2201/40 G02F1/136213		
优先权	1019990028287 1999-07-13 KR 1019990048841 1999-11-05 KR 1019990067761 1999-12-31 KR		
其他公开文献	US20110278607A1		
外部链接	Espacenet USPTO		

摘要(译)

液晶显示器包括彼此面对的第一和第二绝缘基板，以及包括多个行和多个列的多个像素，并且被分成仅包括第一行上的像素的第一像素组和包括第一行上的像素的第二像素组。第二行到最后一行的每个剩余像素。第一像素组的像素具有第一开口率，第二像素组的像素具有不同于第一开口率的第二开口率。第一开口率小于第二开口率，第一开口率为第二开口率的约60%至约80%；并且第一像素组的像素而非第二像素组的像素在开口部分中具有光拦截图案。

