



US 20130265527A1

(19) **United States**

(12) **Patent Application Publication**
Takeuchi et al.

(10) **Pub. No.: US 2013/0265527 A1**
(43) **Pub. Date: Oct. 10, 2013**

(54) **NOVEL LIQUID CRYSTAL DISPLAY DEVICE AND USEFUL LIQUID CRYSTAL COMPOSITION**

(52) **U.S. Cl.**
CPC **G02F 1/133711** (2013.01); **G02F 1/133723** (2013.01)
USPC **349/86**

(75) Inventors: **Kiyofumi Takeuchi**, Kita-adachi-gun (JP); **Masakazu Kaneoya**, Kita-adachi-gun (JP)

(57) **ABSTRACT**

(73) Assignee: **DIC CORPORATION**, Tokyo (JP)

Provided is a liquid crystal display device of VAIPS mode, which uses a liquid crystal material having negative dielectric anisotropy ($\Delta\epsilon < 0$), and has a high response speed, a wide viewing angle, a high transmittance at the time of light transmission, a high black level at the time of light blockage, and an excellent contrast ratio. Disclosed is a liquid crystal display device including a first substrate, a second substrate, and a liquid crystal composition layer having negative dielectric constant, which is interposed between the first substrate and the second substrate, the liquid crystal display device being an electro-optical display device which has a plurality of pixels, and in which each of the pixels is independently controllable and has a pair of a pixel electrode and a common electrode, the two electrodes are provided on at least one substrate of the first substrate and the second substrate, and the long axis of the liquid crystal molecules of the liquid crystal composition layer is in a substantial vertical alignment or a hybrid alignment with respect to the substrate surface.

(21) Appl. No.: **13/825,766**

(22) PCT Filed: **Sep. 22, 2011**

(86) PCT No.: **PCT/JP2011/071642**

§ 371 (c)(1),
(2), (4) Date: **Jun. 21, 2013**

(30) **Foreign Application Priority Data**

Sep. 28, 2010 (JP) 2010-216912

Publication Classification

(51) **Int. Cl.**
G02F 1/1337 (2006.01)

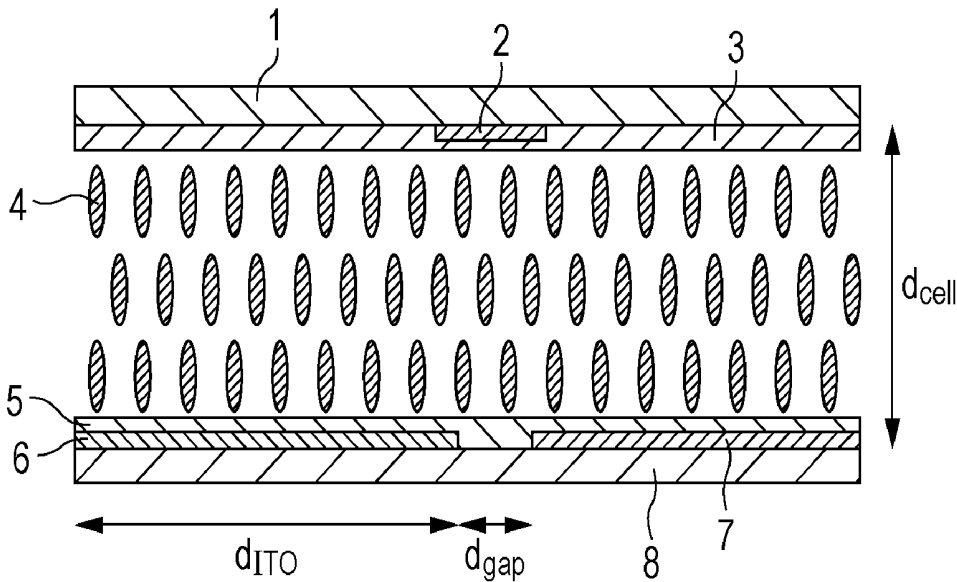

FIG. 1

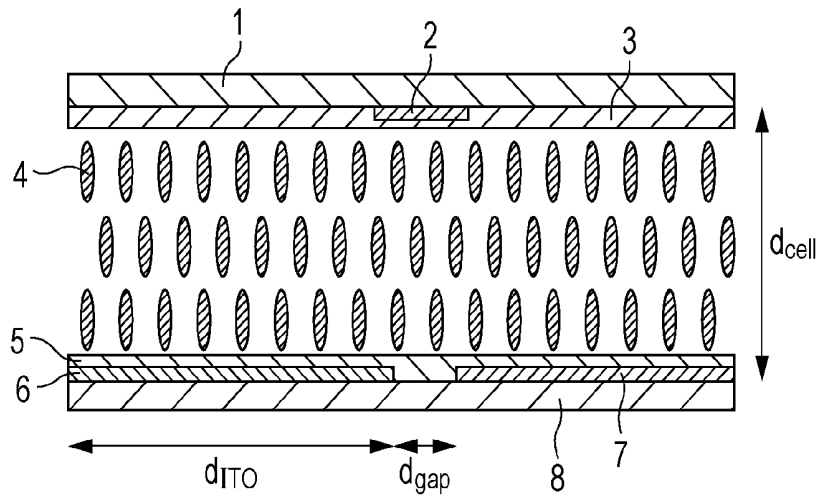

FIG. 2

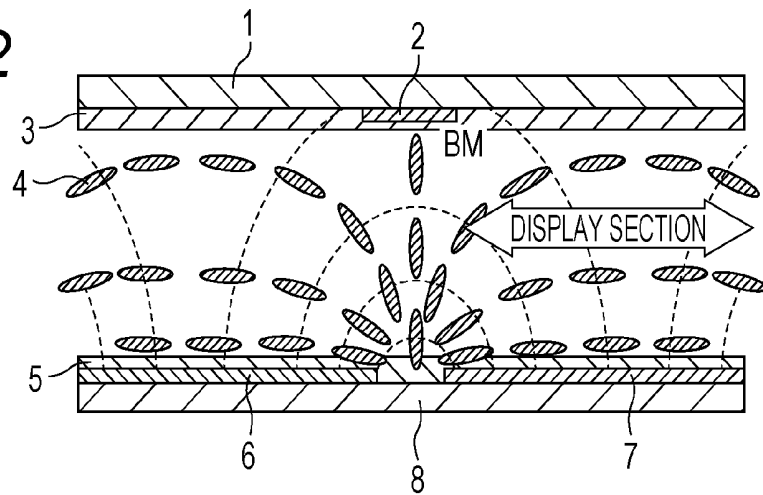

FIG. 3

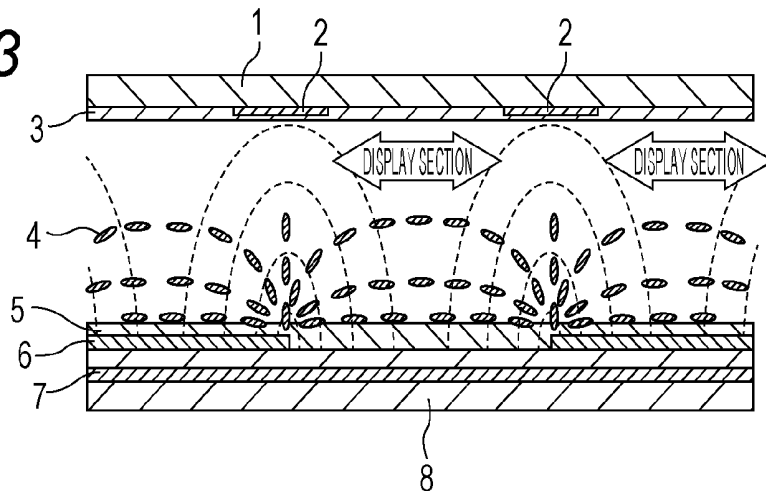

FIG. 4

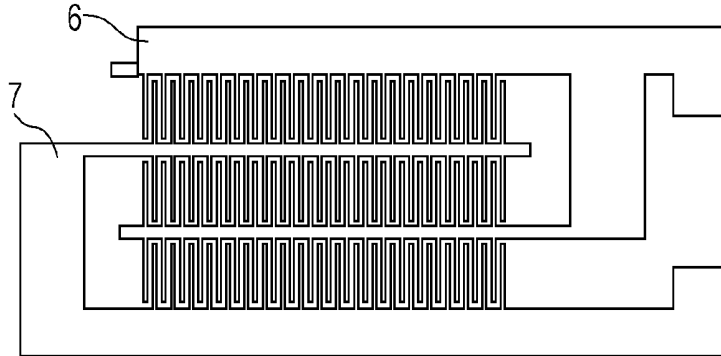

FIG. 5

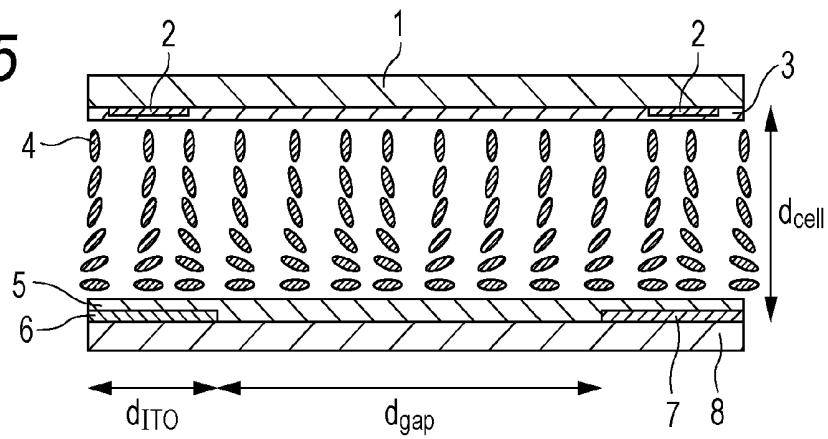

FIG. 6

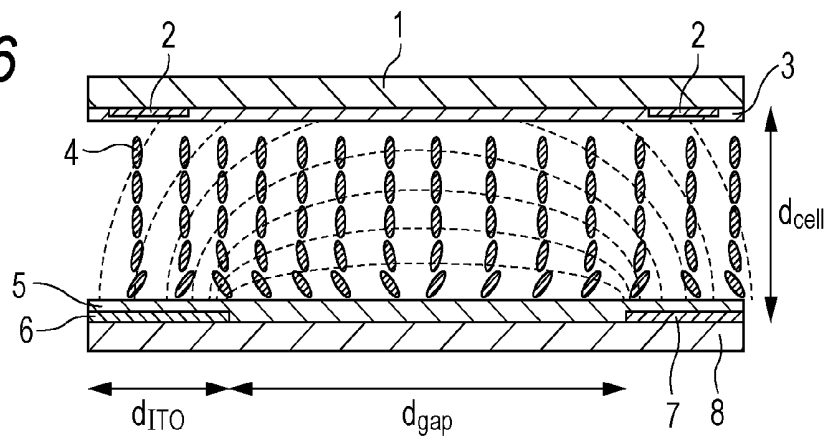

FIG. 7

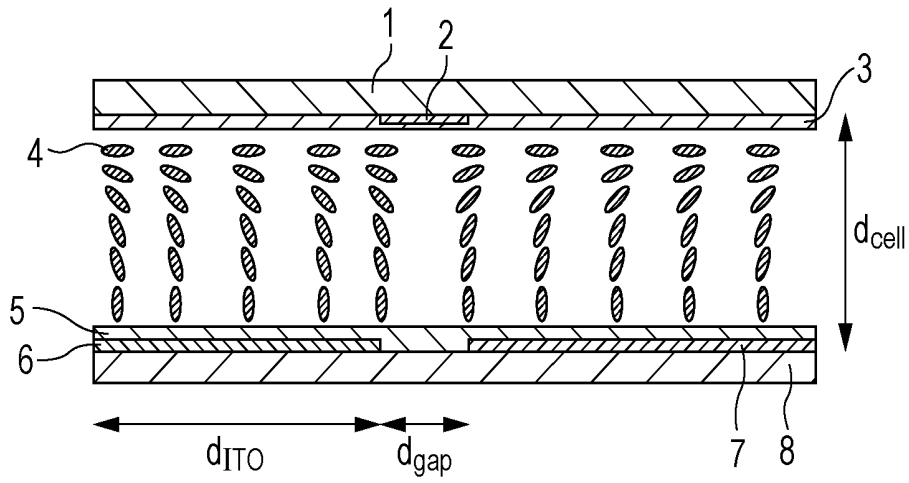
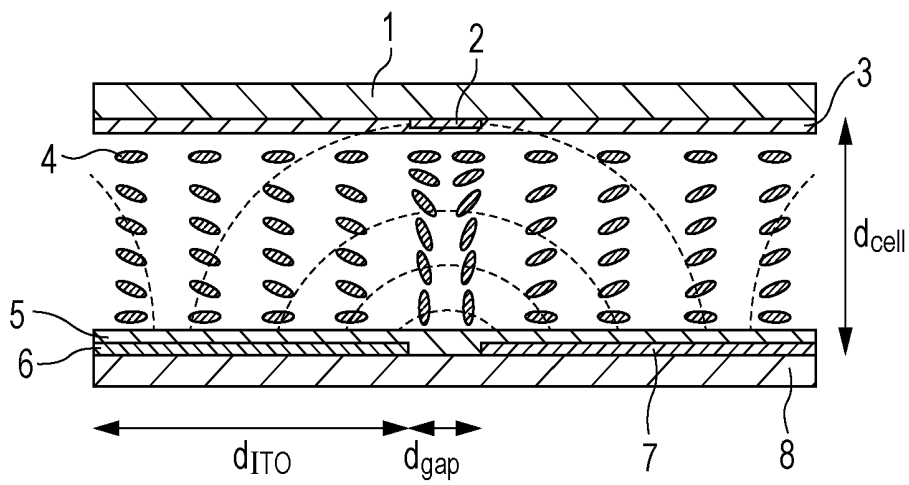

FIG. 8



**NOVEL LIQUID CRYSTAL DISPLAY DEVICE
AND USEFUL LIQUID CRYSTAL
COMPOSITION**

BACKGROUND OF THE INVENTION

[0001] 1. Field of the Invention

[0002] The present invention relates to a liquid crystal display device which uses a nematic crystal composition having negative dielectric anisotropy.

[0003] 2. Description of the Related Art

[0004] Currently, regarding the devices of the active matrix drive system, display modes such as an optically compensated bend (OCB) mode, a vertical alignment (VA) mode and an in-plane switching (IPS) mode have been applied, due to their display quality, to portable terminals, liquid crystal TV sets, projectors, computers, and the like. Since an active matrix display system has a non-linear circuit provided for each pixel, and it has been suggested to use a thin film transistor (TFT) using amorphous silicon or polysilicon, or an organic semiconductor material. Furthermore, as a method for the alignment of liquid crystal molecules to cope with an increase in display size or high definition display, it has been suggested to use a photo-alignment technology. It has been suggested to use a phase difference film in order to obtain wider viewing angle characteristics for the display, or to use a photopolymerizable monomer in order to obtain clear display (SID Sym. Digest, 277 (1993); SID Sym. Digest, 845 (1997); SID Sym. Digest, 1077 (1998); SID Sym. Digest, 461 (1997); Proc. 18th IDRC, 383 (1998); SID Sym. Digest, 1200 (2004); Proc. Asia Display, 577 (1995); and Proc. 18th IDRC, 371 (1998)).

[0005] However, in order for liquid crystal display television sets to completely replace the conventional television sets utilizing cathode ray tubes (CRT) and to also cope with the demand for 3D imaging or field sequential display, liquid crystal TVs are still not satisfactory in terms of the response speed and viewing angle characteristics. For example, the IPS mode is excellent in the viewing angle characteristics, but is not satisfactory in terms of the response speed; and the VA mode exhibits a relatively fast response speed, but is not satisfactory in terms of the viewing angle characteristics. Accordingly, in addition to the use of the overdrive mode, an amelioration for enhancing the apparent response speed of display elements by changing the frame frequency from 60 Hz to a high frequency such as 120 Hz or 240 Hz, has been in progress. However, there are limitations in overcoming the limit of the response speed that is intrinsic to a liquid crystal material, if amelioration is made only in terms of the electronic circuit of these liquid crystal display devices. Thus, there is a demand for a drastic improvement in the response speed as a result of amelioration in the entirety of a display device including a liquid crystal material.

[0006] Furthermore, in order to improve the viewing angle characteristics in regard to the VA mode, a multi-domain vertical alignment (MVA) mode has been suggested in which the viewing angle characteristics are improved by partitioning the pixels, and changing the direction of orientation of the liquid crystal molecules for each of the partitioned pixels. In this mode, it is possible to improve the viewing angle characteristics; however, since it is required to produce liquid crystal cells that have a complicated structure uniformly in order to achieve pixel partitioning, a decrease in production efficiency has been unavoidable.

[0007] As a method of drastically improving such a problem, new drive systems that are different from the conventional drive systems have been suggested. For example, there is known a method of aligning a liquid crystal material having positive dielectric anisotropy ($\Delta\epsilon > 0$) perpendicularly to the substrate surface without voltage application, and driving liquid crystal molecules in a transverse electric field generated by the electrodes disposed on the substrate surface (JP 57-000618 A; JP 50-093665 A; JP 10-153782 A; JP 10-186351A; JP 10-333171A; JP 11-024068 A; JP 2008-020521A; Proc. 13th IDW, 97 (1997); Proc. 13th IDW, 175 (1997); SID Sym. Digest, 319 (1998); SID Sym. Digest, 838 (1998); SID Sym. Digest, 1085 (1998); SID Sym. Digest, 334 (2000); and Eurodisplay Proc., 142 (2009)). In this method, as an electric field in the transverse direction curves, liquid crystal molecules align in a different direction when a voltage is applied; therefore, multiple domains can be formed without performing pixel partitioning as in the case of the MVA mode described above. Accordingly, the method is excellent in view of production efficiency. Liquid crystal display devices of such a mode are called, according to JP 10-153782 A; JP 10-186351A; JP 10-333171A; JP 11-024068 A; JP 2008-020521A; Proc. 13th IDW, 97 (1997); Proc. 13th IDW, 175 (1997); SID Sym. Digest, 319 (1998); SID Sym. Digest, 838 (1998); SID Sym. Digest, 1085 (1998); SID Sym. Digest, 334 (2000); and Eurodisplay Proc., 142 (2009), by various names such as EOC and VA-IPS, but in the present invention, the display mode will be hereinafter abbreviated as "VAIPS".

[0008] However, in the VAIPS mode, since the physical behavior of liquid crystal molecules is different from the conventional method for driving a liquid crystal display device, it is required to select a liquid crystal material under a criterion different from the conventional criteria in connection with the liquid crystal material.

[0009] That is, in general, the threshold voltage (V_c) of Fréedericksz transition in a twisted nematic (TN) mode is represented by the following formula:

$$V_c = \frac{\pi d_{cell}}{d_{cell} + (r_1)} \sqrt{\frac{K11}{\Delta\epsilon}}; \quad \text{[Mathematical Formula 1]}$$

[0010] the same threshold voltage in a super-twisted nematic (STN) mode is represented by the following formula:

$$V_c = \frac{\pi d_{gap}}{d_{cell} + (r_2)} \sqrt{\frac{K22}{\Delta\epsilon}}; \quad \text{[Mathematical Formula 2]}$$

and

[0011] the same threshold voltage in the VA mode is represented by the following formula:

$$V_c = \frac{\pi d_{cell}}{d_{cell} - (r_3)} \sqrt{\frac{K33}{|\Delta\epsilon|}} \quad \text{[Mathematical Formula 3]}$$

wherein V_c represents the Fréedericksz transition (V); π represents the ratio of the circumference of a circle to its diameter; d_{cell} represents the distance (μm) between a first substrate and a second substrate; d_{gap} represents the distance

(μm) between a pixel electrode and a common electrode; d_{ITO} represents the width (μm) of the pixel electrode and/or common electrode; $\langle r1 \rangle$, $\langle r2 \rangle$ and $\langle r3 \rangle$ represent extrapolation lengths (μm); $K11$ represents the elastic constant (N) of splay; $K22$ represents the elastic constant (N) of twist; $K33$ represents the elastic constant (N) of bend; and $\Delta\epsilon$ represents dielectric anisotropy.

[0012] However, in the VAIPS mode, since these general calculation formulas do not fit, and no criteria for selecting the liquid crystal material are available, there has been no progress in the improvement of performance, and consequently, application thereof into liquid crystal display devices has been delayed.

[0013] On the other hand, in regard to the VAIPS mode, disclosures have also been made on preferred compounds as the liquid crystal material to be used (JP 2002-012867 A). However, the liquid crystal composition described in the relevant reference document uses a cyano-based compound, and therefore, the liquid crystal composition is not suitable for active matrix applications.

[0014] On the other hand, liquid crystal display devices also have a problem of aiming to achieve mega contrast (CR) by enhancing the black level with a bright luminance. It has been suggested to improve the numerical aperture so as to enable increasing the pixel display area of LCDs, to apply a luminance enhancing film such as a dual brightness enhancement film (DBEF) or a cholesteric liquid crystal (CLC) film, or to reduce the light leakage caused by protrusions and the like when the liquid crystal is subjected to vertical alignment. Furthermore, there is also a demand for a display which is not easily brought into disorder even under a pressing pressure in a touch panel system.

SUMMARY OF THE INVENTION

[0015] The present invention is intended to solve the problems described above. That is, it is an object of the invention to provide a liquid crystal display device of the VAIPS mode which uses a liquid crystal material having negative dielectric anisotropy ($\Delta\epsilon < 0$), and exhibits a fast response speed, a wide viewing angle, a high transmittance at the time of light transmission, a high black level at the time of light blockage, and an excellent contrast ratio.

[0016] According to an aspect of the invention, there is provided a liquid crystal display device including a first substrate, a second substrate, and a liquid crystal composition layer having negative dielectric anisotropy that is interposed between the first substrate and the second substrate, in which the liquid crystal display device has a plurality of pixels, each of the pixels is independently controllable, the pixel includes a pair of a pixel electrode and a common electrode, these two electrodes are provided on at least one substrate of the first and second substrates, and the major axis of the liquid crystal molecules in the liquid crystal composition layer is in a substantial vertical alignment or a hybrid alignment.

[0017] In the invention, liquid crystal molecules are vertically aligned in at least one substrate surface, but the invention also includes a system in which liquid crystal molecules are aligned vertically to the substrate surface at the other substrate surface as well (hereinafter, referred to as n-VAIPS), and a system in which liquid crystal molecules are aligned horizontally to the substrate at the other surface at the other surface substrate (hybrid alignment) (hereinafter, referred to as n-HBIPS).

[0018] Regarding the electrode structure of the n-VAIPS and n-HBIPS modes according to the invention, the electrode structure of the conventional transverse electric field modes such as IPS, fringe-field switching (FFS) and improved FFS can be applied. Furthermore, the behavior of liquid crystal molecules according to the invention is as schematically described in FIG. 1 to FIG. 3, and in a state under no voltage application (FIG. 1), liquid crystal molecules undergo transition, when a voltage is applied through the electrodes disposed in the transverse direction, from a state of being aligned vertically to the substrate surface to horizontal alignment on the electrodes (FIG. 2). At this time, as the liquid crystal molecules adopt a bend alignment state that is advantageous in the flow effect, the system can attempt an increase in the response speed as compared with the conventional liquid crystal display elements.

[0019] The liquid crystal display element of FIG. 3 is in a state of reorientation of liquid crystal molecules at the time of voltage application in the case where a common electrode is disposed below a pixel electrode, with an insulating layer interposed therebetween, and a further enhancement in contrast can be attempted by an increase in the numerical aperture of the display pixels.

[0020] In a conventional drive method of the VA mode, generally, due to the attempt to widen the viewing angle, it is necessary to define the direction of tilt of the liquid crystal molecules by using zone rubbing, protrusions, slit electrodes and the like, and to promote the formation of multiple domains, and thus the cell configuration tends to become complicated. However, in the n-VAIPS and n-HBIPS modes of the invention, since the direction of tilt of the liquid crystal molecules can be defined by utilizing the phenomenon in which the directions of the line of electric force generated by the applied voltage are different at the two ends of an electrode, the formation of multiple domains can be achieved only by means of the shape of the pixel electrode, and with a relatively simple cell configuration, an increase in the viewing angle and an increase in contrast can be achieved.

[0021] In general, the value of the Fréedericksz transition (V_c) is represented by Formula (1) in the TN mode, by Formula (2) in the STN mode, and by Formula (3) in the VA mode. However, it was found that the following Mathematical Formula (4) is applicable to the liquid crystal display device of the invention:

$$V_c \propto \frac{d_{gap} - \langle r \rangle}{d_{ITO} + \langle r \rangle} \frac{\pi d_{cell}}{d_{cell} - \langle r3 \rangle} \sqrt{\frac{K33}{|\Delta\epsilon|}} \quad \text{[Mathematical Formula 4]}$$

[0022] wherein V_c represents the Fréedericksz transition (V); π represents the ratio of the circumference of a circle to its diameter; d_{cell} represents the distance (μm) between a first substrate and a second substrate; d_{gap} represents the distance (μm) between a pixel electrode and a common electrode; d_{ITO} represents the width (μm) of the pixel electrode and/or common electrode; $\langle r \rangle$, $\langle r' \rangle$ and $\langle r3 \rangle$ represent extrapolation lengths (μm); $K33$ represents the elastic constant (N) of bend; and $\Delta\epsilon$ represents dielectric anisotropy. Regarding the cell configuration according to Mathematical Formula 4, it was found that a decrease in the driving voltage can be attempted by making the value of d_{gap} as low as possible, and the value of d_{ITO} as high as possible, and regarding the liquid crystal composition used, a decrease in the driving voltage can be

attempted by selecting a high absolute value of $\Delta\epsilon$ and a low value of K33. Based on these findings, the inventors found a liquid crystal having negative dielectric anisotropy that is appropriate for the liquid crystal display device described above.

[0023] The most prominent feature of the liquid crystal display device of the invention is that these liquid crystal molecules that can easily start moving start to move about not at the center between two sheets of substrates, but from a site that is shifted toward any one substrate surface and has been brought closer to one substrate, and this feature is different from that of the conventional TN, IPS, VA and OCB modes.

[0024] The invention has improved characteristics such as the response speed, amount of light transmission, light leakage caused by an external pressure such as the use of a touch panel, viewing angle and contrast ratio, and has realized a higher response speed, a larger amount of light transmission, a reduction in light leakage caused by an external pressure, a wider viewing angle, and a higher contrast ratio, as compared with liquid crystal display devices produced by the conventional technologies.

BRIEF DESCRIPTION OF THE DRAWINGS

[0025] FIG. 1 is a diagram illustrating the state of alignment of liquid crystal molecules without voltage application (an example of n-VAIPS);

[0026] FIG. 2 is a diagram illustrating the state of realignment of liquid crystal molecules at the time of voltage application (an example of n-VAIPS);

[0027] FIG. 3 is a diagram illustrating the state of realignment of liquid crystal molecules at the time of voltage application in the case where a common electrode is disposed below a pixel electrode, with an insulating layer interposed therebetween (FFS) (an example of n-VAIPS);

[0028] FIG. 4 is a diagram illustrating the electrode configuration of a test cell;

[0029] FIG. 5 is a diagram illustrating the state of alignment of liquid crystal molecules without voltage application (example 1 of n-HBIPS);

[0030] FIG. 6 is a diagram illustrating the state of realignment of liquid crystal molecules upon voltage application (example 1 of n-HBIPS);

[0031] FIG. 7 is a diagram illustrating the state of alignment of liquid crystal molecules without voltage application (example 2 of n-HBIPS); and

[0032] FIG. 8 is a diagram illustrating the state of realignment of liquid crystal molecules upon voltage application (example 2 of n-HBIPS).

DESCRIPTION OF REFERENCE NUMERALS

- [0033]** 1 FIRST SUBSTRATE
[0034] 2 LIGHT BLOCKING LAYER
[0035] 3 ALIGNMENT LAYER
[0036] 4 LIQUID CRYSTAL
[0037] 5 ALIGNMENT LAYER
[0038] 6 PIXEL ELECTRODE
[0039] 7 COMMON ELECTRODE
[0040] 8 SECOND SUBSTRATE

DETAILED DESCRIPTION OF THE PREFERRED EMBODIMENTS

[0041] In the present invention, regarding the arrangement of the pixel electrode and the common electrode, the same

arrangement as that in the conventional transverse electric field modes such as IPS can be applied, and there are no particular limitations as long as the liquid crystal molecules can be appropriately controlled. However, it is preferable that the distance between the pixel electrode and the common electrode (d_{gap} , μm) be smaller than the width of the pixel electrode or common electrode (d_{ITO} , μm).

[0042] In regard to the liquid crystal display device described above, the liquid crystal composition layer preferably contains two or more kinds of compounds selected from the group of compounds represented by General Formula (LC1) to General Formula (LC5):

[Chemical Formula 1]

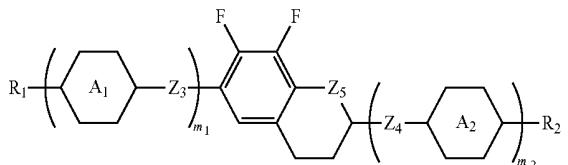
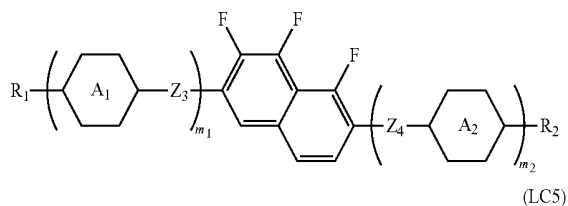
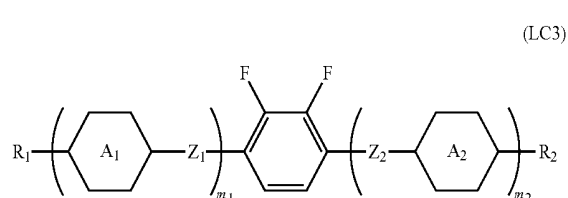
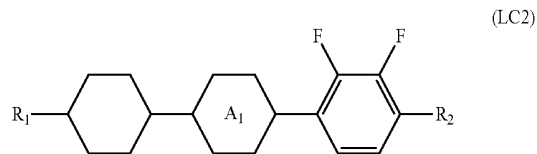
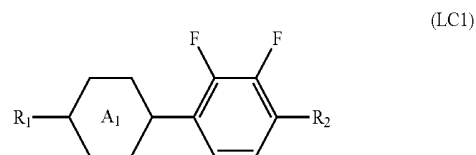

[0043] wherein R_1 and R_2 each independently represent an alkyl group having 1 to 15 carbon atoms; one or two or more CH_2 groups in the alkyl group may be substituted by $-\text{O}-$, $-\text{CH}=\text{CH}-$, $-\text{CO}-$, $-\text{COO}-$, $-\text{COO}-$, $-\text{C}\equiv\text{C}-$, $-\text{CF}_2\text{O}-$ or $-\text{OCF}_2-$, such that O atoms are not directly adjacent to each other; one or two or more H atoms in the alkyl group may be optionally substituted by halogen; A_1 and A_2 each independently represent any one of the following structures:

[Chemical Formula 2]

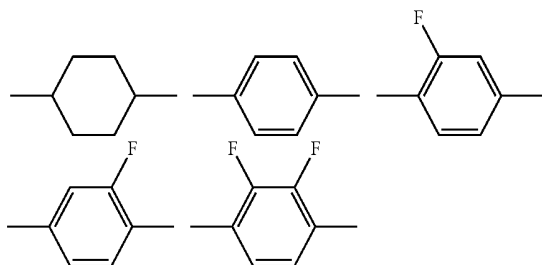

[0044] (wherein one or two or more CH_2 groups in the cyclohexane ring of the structure may be substituted by O atoms, one or two or more CH groups in the benzene ring of the structure may be substituted by N atoms; and one or two or more H atoms in the structure may be substituted by Cl, CF_3 or OCF_3); Z_1 to Z_4 each independently represent a single bond, $-\text{CH}=\text{CH}-$, $-\text{C}\equiv\text{C}-$, $-\text{CH}_2\text{CH}_2-$, $-(\text{CH}_2)_4-$, $-\text{COO}-$, $-\text{OCH}_2-$, $-\text{CH}_2\text{O}-$, $-\text{OCF}_2-$ or $-\text{CF}_2\text{O}-$, while at least one of Z_1 and Z_2 is not a single bond; Z_5 represents a CH_2 group or an O atom; m_1 and m_2 each independently represent 0 to 3, and m_1+m_2 is 1, 2 or 3.

[0045] In the General Formula (LC1) to General Formula (LC5), R_1 preferably represents an alkyl group having 1 to 8 carbon atoms, an alkenyl group having 2 to 8 carbon atoms, or an alkoxy group having 1 to 8 carbon atoms;

[0046] A_1 and A_2 each independently represent preferably a 1,4-cyclohexylene group, a 1,4-phenylene group or a 2,3-difluoro-1,4-phenylene group;

[0047] Z_1 to Z_4 each independently represent preferably a single bond, $-\text{C}\equiv\text{C}-$, $-\text{CH}_2\text{CH}_2-$, $-\text{OCH}_2-$, $-\text{CH}_2\text{O}-$, $-\text{OCF}_2-$ or $-\text{CF}_2\text{O}-$, and more preferably a single bond, $-\text{OCH}_2-$, $-\text{CH}_2\text{O}-$, $-\text{OCF}_2-$ or $-\text{CF}_2\text{O}-$; and m_1 and m_2 each independently represent preferably an integer from 0 to 2, while m_1+m_2 is preferably 1 or 2.

[0048] More preferably, the compound of General Formula (LC2) is a compound represented by any one of the following General Formula (LC2)-1 to General Formula (LC2)-3:

[Chemical Formula 3]

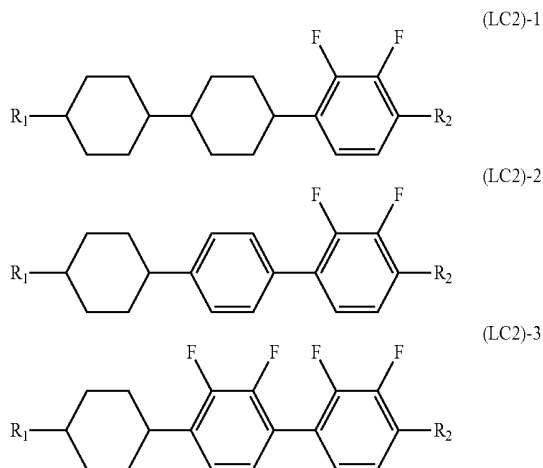

wherein R_1 and R_2 have the same meanings as R_1 and R_2 of the General Formula (LC2), respectively; and/or

[0049] the compound of General Formula (LC3) is a compound represented by any one of the following General Formula (LC3)-1 to General Formula (LC3)-13:

[Chemical Formula 4]

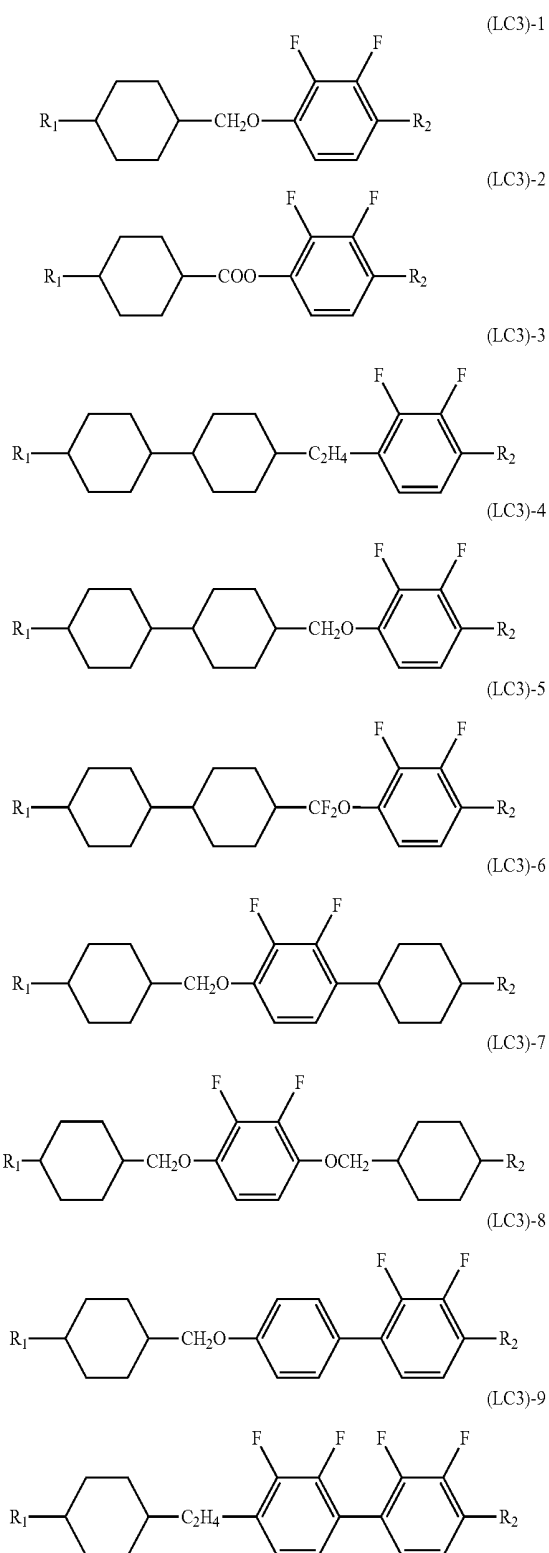

-continued

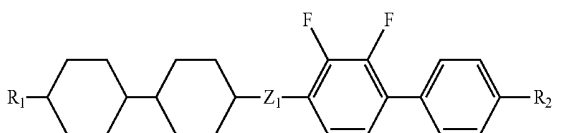
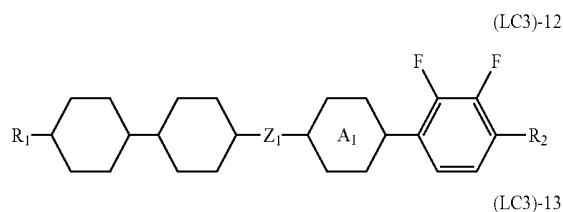
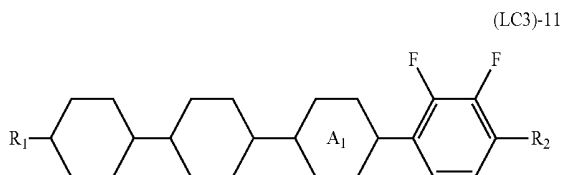
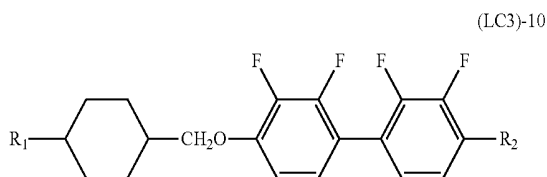

wherein R_1 , R_2 , A_1 and Z_1 have the same meanings as R_1 , R_2 , A_1 and Z_1 of the General Formula (LC3), respectively; and/or

[0050] the compound of General Formula (LC4) is a compound represented by any one of the following General Formula (LC4)-1 to General Formula (LC4)-6, and the compound of General Formula (LC5) is a compound represented by any one of the following General Formula (LC5)-1 to General Formula (LC5)-4:

[Chemical Formula 5]

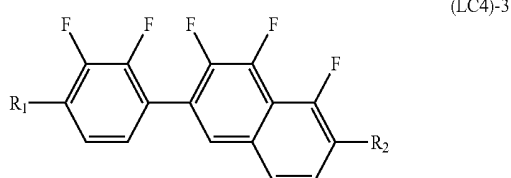
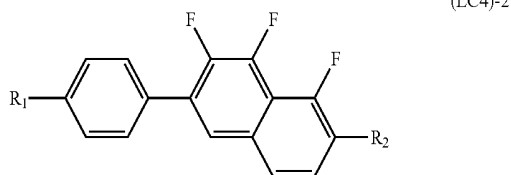
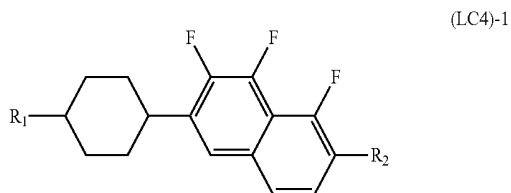

-continued

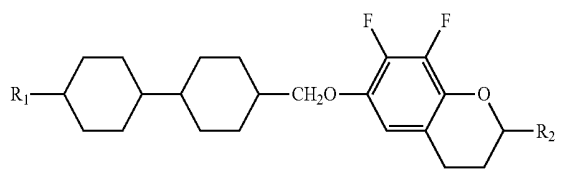
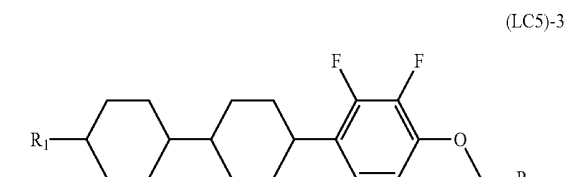
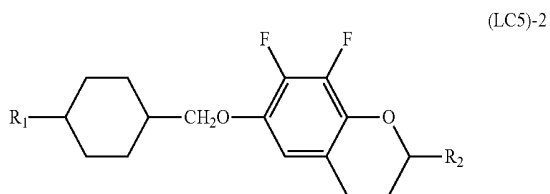
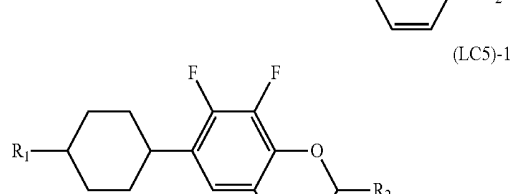
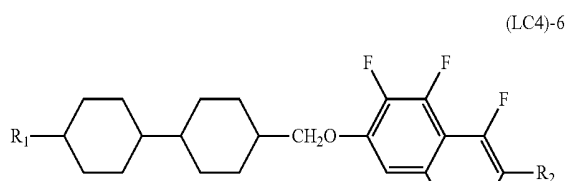
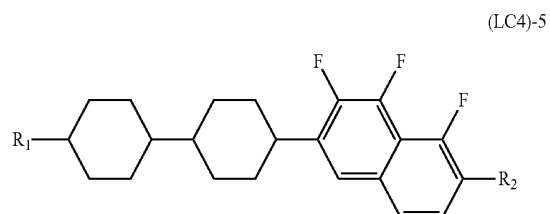
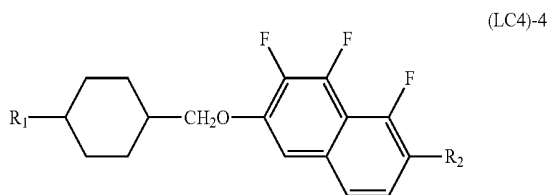

[0051] wherein R_1 and R_2 have the same meanings as R_1 and R_2 of the General Formulas (LC4) and (LC5), respectively. Even more preferably, the compound is a compound represented by any one of General Formulas (LC3) to (LC5), in which at least one of Z_1 and Z_2 is $-\text{OCF}_2-$ or $-\text{CF}_2\text{O}-$.

[0052] Furthermore, it is preferable that the liquid crystal composition layer contain a compound represented by General Formula (LC6):

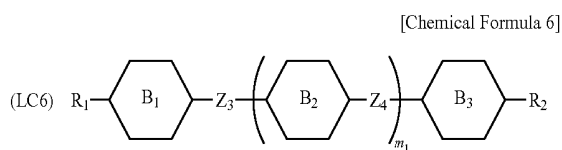

wherein R_1 and R_2 each independently represent an alkyl group having 1 to 15 carbon atoms; one or two or more CH_2 groups in the alkyl group may be substituted by $-\text{O}-$, $-\text{CH}=\text{CH}-$, $-\text{CO}-$, $-\text{COO}-$, $-\text{COO}-$, $-\text{C}\equiv\text{C}-$, $-\text{CF}_2\text{O}-$ or $-\text{OCF}_2-$ such that O atoms are not directly adjacent to each other; one or two or more H atoms in the alkyl group may be optionally substituted by halogen; B_1 to B_3 each independently represent any one of the following:

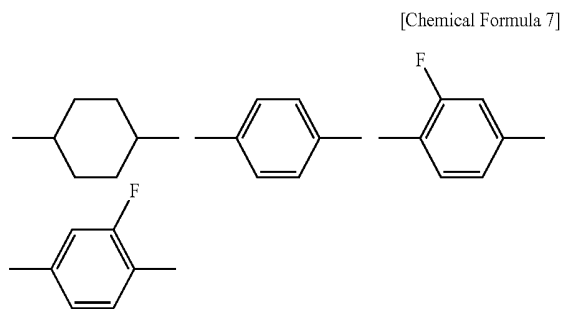

[0053] (wherein one or two or more CH_2CH_2 groups in the cyclohexane ring may be substituted by $-\text{CH}=\text{CH}-$, $-\text{CF}_2\text{O}-$ or $-\text{OCF}_2-$; and one or two or more CH groups in the benzene ring may be substituted by N atoms); Z_3 and Z_4 each independently represent a single bond, $-\text{CH}=\text{CH}-$, $-\text{C}\equiv\text{C}-$, $-\text{CH}_2\text{CH}_2-$, $-(\text{CH}_2)_4-$, $-\text{COO}-$, $-\text{OCH}_2-$, $-\text{CH}_2\text{O}-$, $-\text{OCF}_2-$ or $-\text{CF}_2\text{O}-$; at least one of Z_1 and Z_2 is not a single bond; and m_1 represents 0 to 3.

[0054] The compound represented by General Formula (LC6) is a compound represented by any one of the following General Formula (LC6)-1 to General Formula (LC6)-11:

[Chemical Formula 8]

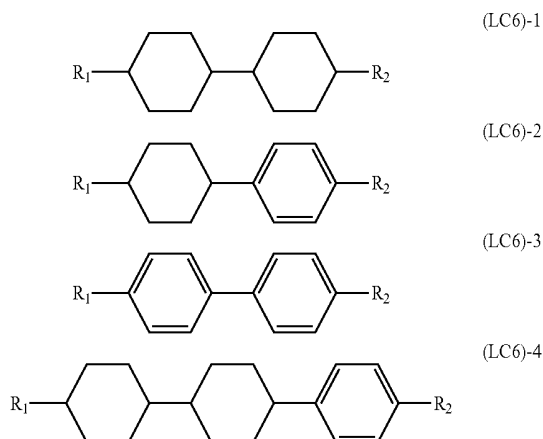

-continued

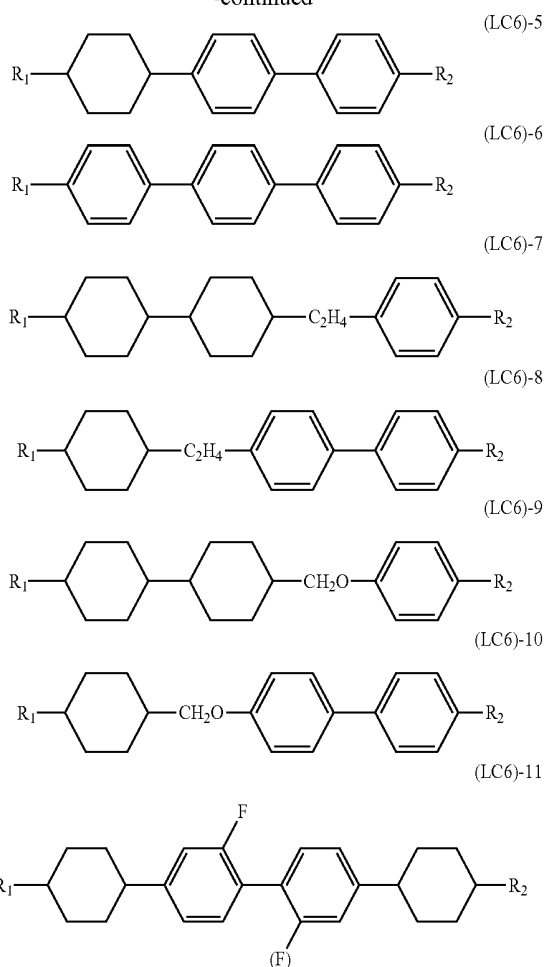

wherein R_1 and R_2 have the same meanings as R_1 and R_2 of the General Formula (LC6), respectively. More preferably, the compound may include one kind or two or more kinds of compounds in which R_1 and/or R_2 in the General Formula (LC6) is an alkenyl group or an alkenyloxy group, and/or any one of Z_1 and Z_2 in the General Formula (LC6) is $-\text{CH}=\text{CH}-$, $-\text{C}\equiv\text{C}-$, $-\text{CH}_2\text{CH}_2-$, $-(\text{CH}_2)_4-$, $-\text{COO}-$, $-\text{OCH}_2-$, $-\text{CH}_2\text{O}-$, $-\text{OCF}_2-$ or $-\text{CF}_2\text{O}-$, and the other is a single bond.

[0055] An even more preferred example of the liquid crystal composition contains a compound represented by General Formula (LC6) in an amount of 30% to 70% by mass, and/or two or more kinds of compounds represented by General Formulas (LC1) to (LC5) in which $\Delta\epsilon$ is -4 or less. Particularly preferably, the liquid crystal composition contains two or more kinds of compounds represented by General Formula (LC2) to (LC5) in which $\Delta\epsilon$ is -4 or less, in an amount of 70% to 30% by mass.

[0056] The viscosity η of the liquid crystal composition is preferably 20 mPa·s or less at 20° C.

[0057] Furthermore, the liquid crystal composition may contain one kind or two or more kinds of polymerizable compounds, and preferably, the polymerizable compound is a disc-shaped liquid crystal compound having a structure in which a benzene derivative, a triphenylene derivative, a truxene derivative, a phthalocyanine derivative or a cyclohexane derivative serves as a parent nucleus at the center of the

molecule, and a linear alkyl group, a linear alkoxy group or a substituted benzoyloxy group is radially substituted as a side chain.

[0058] Specifically, the polymerizable compound is preferably a polymerizable compound represented by General Formula (PC1):

[Chemical Formula 9]

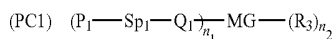

wherein P_1 represents a polymerizable functional group; Sp_1 represents a spacer group having 0 to 20 carbon atoms; Q_1 represents a single bond, $-O-$, $-NH-$, $-NHCOO-$, $-OCONH-$, $-CH=CH-$, $-CO-$, $-COO-$, $-COO-$, $-OOCO-$, $-OOCO-$, $-CH=CH-$, $-CH=CH-COO-$, $-OCO-CH=CH-$ or $-C\equiv C-$; n_1 and n_2 each independently represent 1, 2 or 3; MG represents a mesogen group or a mesogenic supporting group; R_3 represents a halogen atom, a cyano group or an alkyl group having 1 to 25 carbon atoms; one or two or more CH_2 groups in the alkyl group may be substituted by $-O-$, $-S-$, $-NH-$, $-N(CH_3)-$, $-CO-$, $-COO-$, $-OCO-$, $-OOCO-$, $-SCO-$, $-COS-$ or $-C\equiv C-$ such that O atoms are not directly adjacent to each other; or R_3 represents $P_2-Sp_2-Q_2$ (wherein P_2 , Sp_2 and Q_2 each independently have the same meanings as P_1 , Sp_1 and Q_1).

[0059] More preferably, the polymerizable compound is a polymerizable compound in which MG in General Formula (PC1) is represented by the following structure:

[Chemical Formula 10]

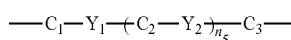

wherein C_1 to C_3 each independently represent a 1,4-phenylene group, a 1,4-cyclohexylene group, a 1,4-cyclohexenyl group, a tetrahydropyrene-2,5-diyl group, a 1,3-dioxane-2,5-diyl group, a tetrahydrothiopyrene-2,5-diyl group, a 1,4-bicyclo(2,2,2)octylene group, a decahydronaphthalene-2,6-diyl group, a pyridine-2,5-diyl group, a pyrimidine-2,5-diyl group, a pyrazine-2,5-diyl group, a 1,2,3,4-tetrahydronaphthalene-2,6-diyl group, a 2,6-naphthylene group, a phenanthrene-2,7-diyl group, a 9,10-dihydrophenanthrene-2,7-diyl group, a 1,2,3,4,4a,9,10a-octahydrophenanthrene-2,7-diyl group, or a fluorene-2,7-diyl group; the 1,4-phenylene group, 1,2,3,4-tetrahydronaphthalene-2,6-diyl group, 2,6-naphthylene group, phenanthrene-2,7-diyl group, 9,10-dihydrophenanthrene-2,7-diyl group, 1,2,3,4,4a,9,10a-octahydrophenanthrene-2,7-diyl group, and fluorene-2,7-diyl group may have, as substituents, one or more of F, Cl, CF_3 , OCF_3 , a cyano group, an alkyl group having 1 to 8 carbon atoms, an alkoxy group, an alkanoyl group, an alkanoyloxy group, an alkenyl group having 2 to 8 carbon atoms, an alkenyloxy group, an alkenoyl group, or an alkenoyloxy group; Y_1 and Y_2 each independently represent $-COO-$, $-OCO-$, $-CH_2CH_2-$, $-OCH_2-$, $-CH_2O-$, $-CH=CH-$, $-C\equiv C-$, $-CH=CHCOO-$, $-OCOCH=CH-$, $-CH_2CH_2COO-$, $-CH_2CH_2OCO-$, $-COOCH_2CH_2-$, $-OCOCH_2CH_2-$, $-CONH-$, $-NHCO-$ or a single bond; and n_5 represents 0, 1 or 2. Sp_1

and Sp_2 each independently represent an alkylene group, and the alkylene group may be substituted with one or more halogen atoms or CN. One or two or more CH_2 groups that are present in this group may be substituted by $-O-$, $-S-$, $-NH-$, $-N(CH_3)-$, $-CO-$, $-COO-$, $-OCO-$, $-OOCO-$, $-SCO-$, $-COS-$ or $-C\equiv C-$ such that O atoms are not directly adjacent to each other, and P_1 and P_2 are each independently represented by any one of the following General Formula (PC1-a) to General Formula (PC1-d):

[Chemical Formula 11]

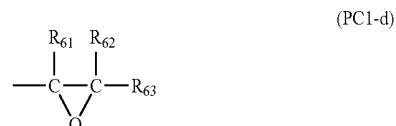
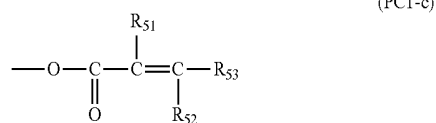
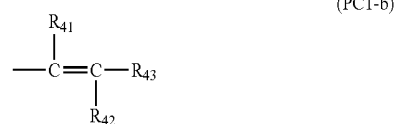
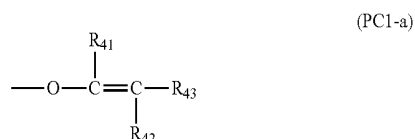

wherein R_{41} to R_{43} , R_{51} to R_{53} , and R_{61} to R_{63} each independently represent a hydrogen atom, a halogen atom, or an alkyl group having 1 to 5 carbon atoms. More specifically, the polymerizable compound is preferably a polymerizable compound in which General Formula (PC1) is represented by General Formula (PC1)-1 or General Formula (PC1)-2:

[Chemical Formula 12]

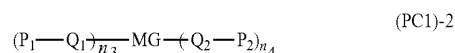
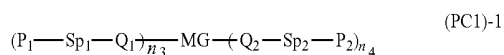

wherein P_1 , Sp_1 , Q_1 , P_2 , Sp_2 , Q_2 and MG have the same meanings as P_1 , Sp_1 , Q_1 , P_2 , Sp_2 , Q_2 and MG of General Formula (PC1); and n_3 and n_4 each independently represent 1, 2 or 3.

[0060] More specifically, the polymerizable compound is more preferably a polymerizable compound in which General Formula (PC1) is represented by any one of General Formula (PC1)-3 to General Formula (PC1)-8:

[Chemical Formula 13]

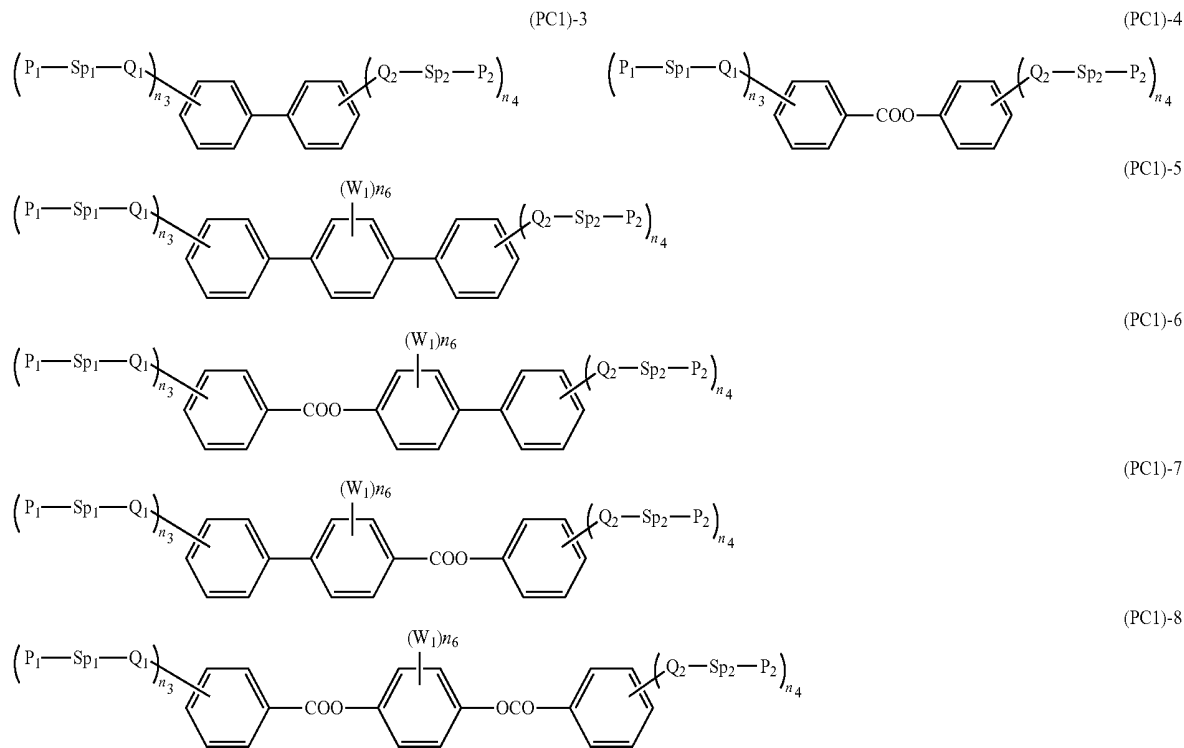

wherein W_1 each independently represents F, CF_3 , OCF_3 , CH_3 , OCH_3 , an alkyl group having 2 to 5 carbon atoms, an alkoxy group, an alkenyl group, $COOW_2$, $OCOW_2$ or $OCOOW_2$ (wherein W_2 represents a linear or branched alkyl group having 1 to 10 carbon atoms, or an alkenyl group having 2 to 5 carbon atoms); and n_6 represents 0, 1, 2, 3 or 4.

[0061] Even more preferably, Sp_1 , Sp_2 , Q_1 and Q_2 in the General Formula (PC1) for the polymerizable compound are all single bonds; n_3 and n_4 are such that n_3+n_4 is from 3 to 6; P_1 and P_2 are represented by formula (7-b); W_1 is F, CF_3 , OCF_3 , CH_3 or OCH_3 ; and n_6 represents 1, 2, 3 or 4.

[0062] Furthermore, the polymerizable compound is also preferably a disc-shaped liquid crystal compound in which MG in General Formula (PC1) is represented by General Formula (PC1)-9:

[Chemical Formula 14]

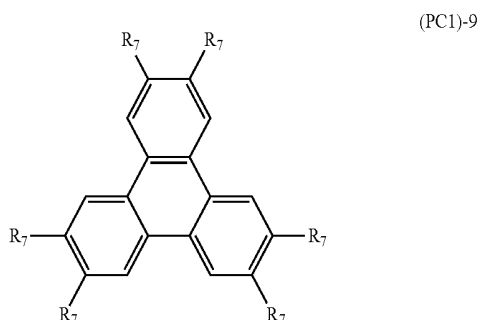

-continued

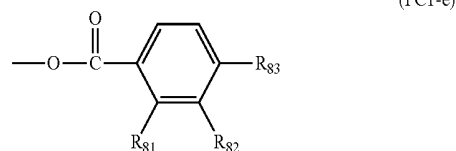

wherein R_2 each independently represents $P_1-Sp_1-Q_1$ or a substituent of General Formula (PC1-e) (wherein P_1 , Sp_1 and Q_1 have the same meanings as P_1 , Sp_1 and Q_1 of General Formula (PC1), respectively); R_{81} and R_{82} each independently represent a hydrogen atom, a halogen atom or a methyl group; R_{83} represents an alkoxy group having 1 to 20 carbon atoms; and at least one hydrogen atom in the alkoxy group is substituted by a substituent represented by any one of the General Formulas (PC1-a) to (PC1-d).

[0063] The amount of use of the polymerizable compound is preferably 0.05% to 2.0% by mass.

[0064] The liquid crystal composition can be used alone for the applications described above, may further include one kind or two or more kinds of oxidation inhibitors, or may further include one kind or two or more kinds of UV absorbers.

[0065] The product ($\Delta n \cdot d$) of the refractive index anisotropy (Δn) of the liquid crystal composition with the distance (d) between the first substrate and the second substrate of a display device is, in the case of a vertical alignment, preferably 0.20 to 0.59; in the case of a hybrid alignment, preferably 0.21 to 0.61; in the case of a vertical alignment, particularly preferably 0.30 to 0.40; and in the case of a hybrid alignment, particularly preferably 0.32 to 0.44.

[0066] On each of the surfaces that are brought into contact with the liquid crystal composition on the first substrate and the second substrate of the display device, an alignment film formed from a polyimide (PI), a polyamide, a chalcone, a cinnamate, a cinnamoyl or the like can be provided so as to align the liquid crystal composition, and the alignment film may also be a film produced using a photo-alignment technology.

[0067] In the case of a vertical alignment, the tilt angle of the long axis of the liquid crystal molecules in the liquid crystal composition on the substrate surface is preferably 85° to 90°, and in the case of a hybrid alignment, the tilt angle of the long axis of the liquid crystal molecules in the liquid crystal composition on the substrate surface of one of the first substrate and the second substrate is preferably 85° to 90°, while the tilt angle of the long axis of the liquid crystal molecules on the other substrate surface is preferably 3° to 20°.

EXAMPLES

[0068] Hereinafter, some of the best modes of the invention will be described in detail by way of Examples, but the invention is not intended to be limited to these Examples. Furthermore, the unit “percent (%)” for the compositions of the following Examples and Comparative Examples means “percent (%) by mass”.

[0069] The properties of the liquid crystal composition will be indicated as follows.

[0070] T_{N-I} : Nematic phase-isotropic liquid phase transition temperature (° C.) as the upper limit temperature of the liquid crystal phase

[0071] $\Delta\epsilon$: Dielectric anisotropy

[0072] Δn : Refractive index anisotropy

[0073] V_{sat} : Applied voltage at which the transmittance changes by 90% when square waves are applied at a frequency of 1 kHz

[0074] The following abbreviations are used for the indication of compounds.

n (number) at the end	$C_nH_{2n+1}-$
-2-	$-CH_2CH_2-$
-1O-	$-CH_2O-$
-O1-	$-OCH_2-$
-On	$-OC_nH_{2n+1}$
-1=1-	$-HC=CH-$
ndm-	$C_nH_{2n+1}-HC=CH-(CH_2)_{m-1}-$

[Chemical Formula 15]

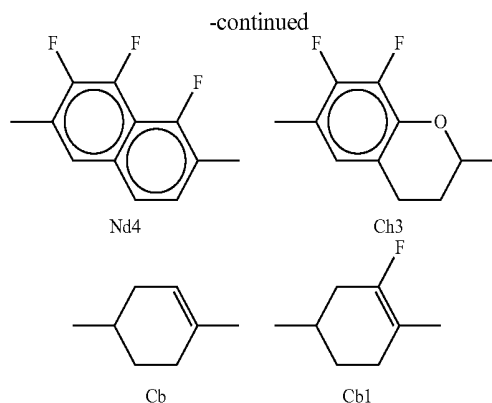
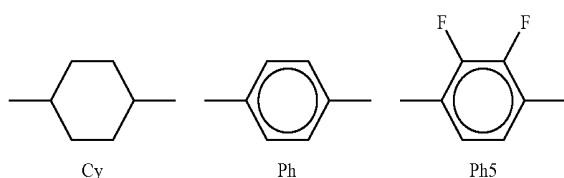

Example 1

[0075] An electrode structure such as illustrated in FIG. 4 was produced on a second substrate, and a first substrate having no electrode structure provided thereon was used. An alignment film of vertical alignment was formed on each of the respective surfaces that faced each other. The liquid crystals having negative dielectric anisotropy indicated as Example 1 in Table 1 were interposed between the first substrate and the second substrate, and thus a liquid crystal display device was produced (cell thickness: 4.0 μm , alignment film: SE-5300).

Comparative Example 1

[0076] A conventional VA liquid crystal display device was produced using the liquid crystal composition used in Example 1, and the property values were measured. The results are presented together in Table 1.

[0077] The liquid crystal display device of the invention realized a higher response speed, a larger amount of light transmission, a reduction in light leakage caused by external pressure, a wider viewing angle, and a higher contrast ratio, as compared with the liquid crystal display device of Comparative Example 1 in which the same liquid crystals having negative dielectric anisotropy were interposed.

Example 2

[0078] An electrode structure such as illustrated in FIG. 4 was produced on a second substrate, and a first substrate having no electrode structure provided thereon was used. An alignment film of vertical alignment was formed on each of the other sides of the respective surfaces that faced each other, and an alignment film of horizontal orientation was formed on each of the reverse sides. The liquid crystals having negative dielectric anisotropy indicated as Example 2 in Table 1 were interposed between the first substrate and the second substrate, and thus a liquid crystal display device was produced (cell thickness: 4.0 μm , alignment films: SE-5300, AL-1051). The liquid crystal display device realized a higher response speed, a larger amount of light transmission, a reduction in light leakage caused by external pressure, a wider viewing angle, and a higher contrast ratio, as compared with a conventional VA liquid crystal display device in which the same liquid crystals having negative dielectric anisotropy were interposed.

Example 3

[0079] An electrode structure such as illustrated in FIG. 4 was produced on a second substrate, and a first substrate having no electrode structure provided thereon was used. An alignment film of vertical alignment was formed on each of the respective surfaces that faced each other. The liquid crystals having negative dielectric anisotropy indicated as Example 3 in Table 1 and 0.3% by mass of 2-methylacrylic acid 4'-{2-[4-(2-acryloyloxyethyl)phenoxy]carbonyl}

While a driving voltage was applied between the electrodes, ultraviolet radiation was irradiated for 600 seconds (3.0 J/cm²), and thus a polymerization treatment was carried out. [0082] The liquid crystal display device realized a higher response speed, a larger amount of light transmission, a reduction in light leakage caused by external pressure, a wider viewing angle, and a higher contrast ratio, as compared with a conventional VA liquid crystal display device in which the same liquid crystals having negative dielectric anisotropy were interposed.

TABLE 1

	Example 1	Example 2	Example 3	Example 4	Comparative Example 1
0d1-Cy-Cy-3	20	20	20	20	20
3-Cy-Cy-2	15	15	15	15	15
3-Cy-Ph-O1	5	5	5	5	5
0d1-Cy-1O-Ph5-O1-Cy-2	11	11	11	11	11
0d1-Cy-1O-Ph5-O1-Cy-3	11	11	11	11	11
0d1-Cy-1O-Ph5-O1-Cy-4	11	11	11	11	11
0d1-Cy-1O-Ph5-O1-Cy-5	11	11	11	11	11
0d1-Cy-Cy-1O-Ph5-O3d0	4	4	4	4	4
0d1-Cy-Cy-1O-Ph5-O4d0	4	4	4	4	4
0d1-Cy-1O-Ph5-O1-Cy-Cy-2	4	4	4	4	4
0d1-Cy-1O-Ph5-O1-Cy-Cy-3	4	4	4	4	4
Sum of composition ratios (%)	100	100	100	100	100
Tni/° C.	82.4	82.4	82.4	82.4	82.4
Δn (20°)	0.074	0.074	0.074	0.074	0.074
η ₂₀ /mPa · s	16.1	16.1	16.1	16.1	16.1
Δε (20° C.)	-4.7	-4.7	-4.7	-4.7	-4.7
V _{sat} /V (25° C.)	4.32	4.13	4.18	4.10	4.78
τ _{r,d} /msec (25° C., 6 V)	3.7	4.1	4.3	4.4	19.6

ethyl}biphenyl-4-yl ester were interposed between the first substrate and the second substrate, and thus a liquid crystal display device was produced (cell thickness: 4.0 μm, alignment film: SE-5300). While a driving voltage was applied between the electrodes, ultraviolet radiation was irradiated for 600 seconds (3.0 J/cm²), and thus a polymerization treatment was carried out.

[0080] The liquid crystal display device realized a higher response speed, a larger amount of light transmission, a reduction in light leakage caused by external pressure, a wider viewing angle, and a higher contrast ratio, as compared with a conventional VA liquid crystal display device in which the same liquid crystals having negative dielectric anisotropy were interposed.

Example 4

[0081] An electrode structure such as illustrated in FIG. 4 was produced on a second substrate, and a first substrate having no electrode structure provided thereon was used. An alignment film of vertical alignment was formed on each of the other sides of the respective surfaces that faced each other, and an alignment film of horizontal orientation was formed on each of the reverse sides. The liquid crystals having negative dielectric anisotropy indicated as Example 4 in Table 1 were interposed between the first substrate and the second substrate, and thus a liquid crystal display device was produced (cell thickness: 4.0 μm, alignment films: SE-5300, AL-1051).

Examples 5 and 6

[0083] A liquid crystal display device of Example 5 was produced in the same manner as in Example 1 by interposing the liquid crystals having negative dielectric anisotropy indicated in Table 2, and a liquid crystal display device of Example 6 was produced in the same manner as in Example 1.

TABLE 2

	Example 5	Example 6
3-Cy-1O-Ph5-O2	11	11
5-Cy-1O-Ph5-O2	10	10
0d1-Cy-Cy-3	20	
0d1-Cy-Cy-5		20
0d3-Cy-Cy-3	10	10
3-Cy-1=1-Cy-3	10	10
3-Cy-Cy-2		
3-Cy-Ph-O1		
0d1-Cy-1O-Ph5-O1-Cy-2		
0d1-Cy-1O-Ph5-O1-Cy-3		5
0d1-Cy-1O-Ph5-O1-Cy-4		
0d1-Cy-1O-Ph5-O1-Cy-5		
0d1-Cy-Cy-1O-Ph5-O3d0		5
0d1-Cy-Cy-1O-Ph5-O4d0		5
2-Cy-Cy-1O-Ph5-O2	5	5
3-Cy-Cy-1O-Ph5-O2	12	12

TABLE 2-continued

	Example 5	Example 6
4-Cy-Cy-1O-Ph5-O2	5	5
0d1-Cy-1O-Ph5-O1-Cy-Cy-1d0	12	
0d1-Cy-1O-Ph5-O1-Cy-Cy-2	5	
0d1-Cy-1O-Ph5-O1-Cy-Cy-3		2
Sum of composition ratios (%)	100	100
Tni/° C.	79.6	78.9
An (20°)	0.074	0.075
$\eta_{20}/\text{mPa} \cdot \text{s}$	17.8	18.2
$\Delta\epsilon$ (20° C.)	-4.8	-4.8
Vsat/V (25° C.)	4.24	4.27
$\tau_r + d/\text{msec}$ (25° C., 6V)	3.7	3.8

[0084] The liquid crystal display devices of Examples 5 and 6 realized higher response speeds, larger amounts of light transmission, a reduction in light leakage caused by external pressure, wider viewing angles, and higher contrast ratios, as compared with conventional VA liquid crystal display devices in which the same liquid crystals having negative dielectric anisotropy were interposed.

Examples 7 to 10

[0085] A liquid crystal display device of Example 7 was produced in the same manner as in Example 1 by interposing the liquid crystals having negative dielectric anisotropy indicated in Table 3; a liquid crystal display device of Example 8 was produced in the same manner as in Example 1; a liquid crystal display device of Example 9 was produced in the same manner as in Example 1; and a liquid crystal display device of Example 10 was produced in the same manner as in Example 1.

TABLE 3

	Example 7	Example 8	Example 9	Example 10
0d1-Cy-1O-Ph5-O3d0				5
0d1-Cy-1O-Ph5-O4d0				5
0d1-Cy-Cy-3	10			4
3-Cy-Cy-2	10	18		10
3-Cy-Cy-4		6	15	3
3-Cy-Ph-O2	12	12	15	4
5-Ph-Ph-1	10	3	3	10
0d1-Cy-1O-Ph5-O1-Cy-2	10	10	10	
0d1-Cy-1O-Ph5-O1-Cy-3	12	12	12	
0d1-Cy-1O-Ph5-O1-Cy-4	12	12	12	
0d1-Cy-1O-Ph5-O1-Cy-5	10	10	10	
0d1-Cy-Cy-1O-Ph5-O1d0				10
0d1-Cy-Cy-1O-Ph5-O2d0				10
0d1-Cy-Cy-1O-Ph5-O3d0				15
0d1-Cy-Cy-1O-Ph5-O4d0				15
3-Cy-Cy-Ph-1	6	3		6
0d1-Cy-1O-Ph5-O1-Cy-Cy-2	4	4	4	
0d1-Cy-1O-Ph5-O1-Cy-Cy-3	4	4	4	
Sum of composition ratios (%)	100	100	100	100
Tni/° C.	75.5	81.8	83.5	75.1
An (20°)	0.088	0.077	0.078	0.087
$\eta_{20}/\text{mPa} \cdot \text{s}$	16	16.5	20.2	15.5
$\Delta\epsilon$ (20° C.)	-4.2	-4.2	-4.2	-4.3
Vsat/V (25° C.)	4.52	4.57	4.55	4.50
$\tau_r + d/\text{msec}$ (25° C., 6V)	3.6	3.6	3.8	3.5

[0086] The liquid crystal display devices of Examples 7 to 10 realized higher response speeds, larger amounts of light transmission, a reduction in light leakage caused by external

pressure, wider viewing angles, and higher contrast ratios, as compared with conventional VA liquid crystal display devices in which the same liquid crystals having negative dielectric anisotropy were interposed.

Examples 11 to 13

[0087] A liquid crystal display device of Example 11 was produced in the same manner as in Example 1 by interposing the liquid crystals having negative dielectric anisotropy indicated in Table 4; a liquid crystal display device of Example 12 was produced in the same manner as in Example 1; and a liquid crystal display device of Example 13 was produced in the same manner as in Example 1.

TABLE 4

	Example 11	Example 12	Example 13
2-Cy-2-Nd4-O2		4	4
2-Cy-2-Nd4-O4		4	4
3-Cy-1O-Ch3-5	3		
3-Cy-1O-Nd4-O4	3	4	4
5-Cy-1O-Ch3-5	3		
5-Cy-1O-Nd4-O2	2		
5-Cy-1O-Nd4-O3	3		4
0d1-Cy-Cy-5		23	
0d3-Cy-Cy-3		10	
1d1-Cy-Cy-3		8	
3-Cy-Cy-2	15		
3-Cy-Cy-4	7	6	22
3-Cy-Cy-5	7		22
3-Cy-Ph-2		15	15
3-Cy-Ph-O1	5		
3-Cy-Ph-O2	5		
5-Ph-Ph-1	6		
2-Cy-Cy-1O-Nd4-O2	3	4	4
2-Cy-Cy-1O-Nd4-O4	2	4	4
3-Cy-2-Cy-1O-Nd4-O2	4		
3-Cy-2-Cy-1O-Nd4-O3	4		
3-Cy-Cy-1O-Ch3-5	3		
3-Cy-Cy-1O-Nd4-O4	3	4	4
4-Cy-Cy-1O-Ch3-5	3		
4-Cy-Cy-1O-Nd4-O2	2	4	4
4-Cy-Cy-2-Nd4-O2		6	6
3-Cy-Cy-Ph-1	8		3
Sum of composition ratios (%)	100	100	100
Tni/° C.	92	90	91
An (20°)	0.093	0.092	0.093
$\eta_{20}/\text{mPa} \cdot \text{s}$	24.9	24.1	25.5
$\Delta\epsilon$ (20° C.)	-3.3	-3.2	-3.2
Vsat/V (25° C.)	5.16	5.32	5.28
$\tau_r + d/\text{msec}$ (25° C., 6V)	4.7	4.7	4.8

[0088] The liquid crystal display devices of Examples 11 to 13 realized higher response speeds, larger amounts of light transmission, a reduction in light leakage caused by external pressure, wider viewing angles, and higher contrast ratios, as compared with conventional VA liquid crystal display devices in which the same liquid crystals having negative dielectric anisotropy were interposed.

Examples 14 and 15

[0089] A liquid crystal display device of Example 14 was produced in the same manner as in Example 1 by interposing the liquid crystals having negative dielectric anisotropy indicated in Table 5, and a liquid crystal display device of Example 15 was produced in the same manner as in Example 1.

TABLE 5

	Example 14	Example 15
3-Cy-1O-Ch3-5	2	
3-Cy-2-Ph5-O2	6	10
3-Cy-Ph5-O2		10
4-Cy-1O-Nd4-O2	5	5
5-Cy-1O-Ch3-5	2	
0d1-Cy-Cy-5		16
3-Cy-1=1-Cy-3		10
3-Cy-Cy-2	15	
3-Cy-Cy-4	7	
3-Cy-Cy-5	7	
3-Cy-Ph-O1	6	
3-Cy-2-Cy-1O-Nd4-O2	3	
3-Cy-2-Cy-1O-Nd4-O3	3	
3-Cy-Cy-1O-Ch3-5	2	
3-Cy-Cy-2-Ph5-O2	7	10
3-Cy-Cy-Ph5-1	7	10
3-Cy-Cy-Ph5-O2	7	10
4-Cy-Cy-1O-Ch3-5	2	
5-Cy-Cy-1O-Nd4-O3	5	5
0d1-Cy-Cy-Ph-1		14
3-Cy-Cy-Ph-1	14	
Sum of composition ratios	100	100
Tni/° C.	87	85
An (20°)	0.086	0.085
η20/mPa · s	24.2	23.8
Δε (20° C.)	-2.7	-2.5
Vsat/V (25° C.)	5.72	5.81
tr + d/msec (25° C., 6V)	4.7	4.7

[0090] The liquid crystal display devices of Examples 14 and 15 realized higher response speeds, larger amounts of light transmission, a reduction in light leakage caused by external pressure, wider viewing angles, and higher contrast ratios, as compared with conventional VA liquid crystal display devices in which the same liquid crystals having negative dielectric anisotropy were interposed.

Examples 16 to 18

[0091] A liquid crystal display device of Example 16 was produced in the same manner as in Example 1 by interposing the liquid crystals having negative dielectric anisotropy indicated in Table 6; a liquid crystal display device of Example 17 was produced in the same manner as in Example 1; and a liquid crystal display device of Example 18 was produced in the same manner as in Example 1.

TABLE 6

	Example 16	Example 17	Example 18
3-Cy-1O-Ch3-5	3		
3-Cy-1O-Nd4-O4	3		4
5-Cy-1O-Ch3-5	3		
5-Cy-1O-Nd4-O2	2	4	4
5-Cy-1O-Nd4-O3	3	4	4
3-Cy-Cy-2	7	21	11
3-Cy-Cy-4	11	7	7
3-Cy-Cy-5	11	7	7
3-Cy-Ph-2			6
3-Cy-Ph-O1	7	13	7
3-Cy-Ph-O2	7	13	7
5-Ph-Ph-1	6		13
2-Cy-Cy-1O-Nd4-O2	3	4	4
2-Cy-Cy-1O-Nd4-O4	2		
3-Cy-2-Cy-1O-Nd4-O2	3	4	4
3-Cy-2-Cy-1O-Nd4-O3	3	4	4
3-Cy-Cy-1O-Ch3-5	2	3	
3-Cy-Cy-1O-Nd4-O4	3	4	4

TABLE 6-continued

	Example 16	Example 17	Example 18
4-Cy-Cy-1O-Ch3-5	2	3	
4-Cy-Cy-1O-Nd4-O2	2		
3-Cy-Cy-Ph-1	8	9	6
3-Cy-Ph-Ph-1	9		6
Sum of composition ratios (%)	100	100	98
Tni/° C.	86	81	76
An (20°)	0.091	0.082	0.104
η20/mPa · s	20	19.2	17.8
Δε (20° C.)	-2.7	-2.5	-2.3
Vsat/V (25° C.)	5.71	5.93	6.12
tr + d/msec (25° C., 6V)	3.7	3.6	3.7

[0092] The liquid crystal display devices of Examples 16 to 18 realized higher response speeds, larger amounts of light transmission, a reduction in light leakage caused by external pressure, wider viewing angles, and higher contrast ratios, as compared with conventional VA liquid crystal display devices in which the same liquid crystals having negative dielectric anisotropy were interposed.

Examples 19 to 22

[0093] A liquid crystal display device of Example 19 was produced in the same manner as in Example 1 by interposing the liquid crystals having negative dielectric anisotropy indicated in Table 7; a liquid crystal display device of Example 20 was produced in the same manner as in Example 1; a liquid crystal display device of Example 21 was produced in the same manner as in Example 1; and a liquid crystal display device of Example 22 was produced in the same manner as in Example 1.

TABLE 7

	Example 19	Example 20	Example 21	Example 22
3-Cy-1O-Ph5-O2		2		11
5-Cy-1O-Ph5-O2		2		10
0d1-Cy-Cy-3			30	
0d1-Cy-Cy-5	4	4	10	20
0d3-Cy-Cy-3				10
3-Cy-1=1-Cy-3				10
3-Cy-Cy-2	4	4		
3-Cy-Cy-4	4	4		
3-Cy-Cy-5	4	4		
3-Cy-Ph-O1	2	2		
5-Ph-Ph-1	20	20		
0d1-Cy-1O-Ph5-O1-Cy-1d0				12
0d1-Cy-1O-Ph5-O1-Cy-2	7	8	10	
0d1-Cy-1O-Ph5-O1-Cy-3	7	8	12	
0d1-Cy-1O-Ph5-O1-Cy-4	7	8	12	
0d1-Cy-1O-Ph5-O1-Cy-5	5		10	
0d1-Cy-Cy-1O-Ph5-O3d0	13		6	
0d1-Cy-Cy-1O-Ph5-O4d0	13		6	
2-Cy-Cy-1O-Ph5-O2		13		5
3-Cy-Cy-1O-Ph5-O2		13		12
4-Cy-Cy-1O-Ph5-O2		13		5
0d1-Cy-1O-Ph5-O1-Cy-Cy-2	5		2	5
0d1-Cy-1O-Ph5-O1-Cy-Cy-3	5	5	2	
Sum of composition ratios (%)	100	110	100	100
Tni/° C.	80.5	79.8	83.6	83.1
An (20°)	0.102	0.101	0.075	0.075
η20/mPa · s	23.9	27.6	15.1	18
Δε (20° C.)	-4.1	-4.1	-4.8	-4.8

TABLE 7-continued

	Example 19	Example 20	Example 21	Example 22
Vsat/V (25° C.)	4.54	4.42	4.08	4.12
τr + d/msec (25° C., 6 V)	4.8	5.0	3.4	3.6

[0094] The liquid crystal display devices of Examples 19 to 22 realized higher response speeds, larger amounts of light transmission, a reduction in light leakage caused by external pressure, wider viewing angles, and higher contrast ratios, as compared with conventional VA liquid crystal display devices in which the same liquid crystals having negative dielectric anisotropy were interposed.

Examples 23 to 26

[0095] A liquid crystal display device of Example 23 was produced in the same manner as in Example 1 by interposing the liquid crystals having negative dielectric anisotropy indicated in Table 8; a liquid crystal display device of Example 24 was produced in the same manner as in Example 1; a liquid crystal display device of Example 25 was produced in the same manner as in Example 1; and a liquid crystal display device of Example 26 was produced in the same manner as in Example 1.

TABLE 8

	Example 23	Example 24	Example 25	Example 26
2-Cy-2-Nd4-O2		10		10
3-Cy-1O-Ch3-O5	7		10	
3-Cy-2-Nd4-O4		10		10
4-Cy-2-Nd4-O2		10		10
5-Cy-1O-Ch3-O5	7		10	
5-Cy-2-Nd4-O2		5		5
0d1-Cy-Cy-3	30	40		
0d1-Cy-Cy-5			15	20
3-Cy-Cy-4			15	14
3-Cy-Ph-O2				10
5-Ph-Ph-1	10		10	
2-Cy-Cy-2-Nd4-O2		4		4
3-Cy-Cy-1O-Ph5-O1	4		3	
3-Cy-Cy-1O-Ph5-O2	9		5	
3-Cy-Cy-2-Ph5-O2	10		10	
3-Cy-Cy-Ph5-O2	10		10	
4-Cy-Cy-1O-Ph5-O1	4		3	
4-Cy-Cy-2-Nd4-O2		4		4
0d1-Cy-Cy-Ph-1	9	6	9	4
0d1-Cy-Ph-Ph-3		5		3
0d3-Cy-Cy-Ph-1		6		6
Sum of composition ratios (%)	100	100	100	100
Tni/° C.	82.7	82.3	80.9	81.8
Δn (20°)	0.087	0.098	0.084	0.097
η20/mPa · s	19.4	18.1	26	22.7
Δε (20° C.)	-3.1	-3.1	-3.1	-3.2
Vsat/V (25° C.)	5.37	5.29	5.42	5.25
τr + d/msec (25° C., 6 V)	3.7	3.6	4.9	4.6

[0096] The liquid crystal display devices of Examples 23 to 26 realized higher response speeds, larger amounts of light transmission, a reduction in light leakage caused by external pressure, wider viewing angles, and higher contrast ratios, as compared with conventional VA liquid crystal display devices in which the same liquid crystals having negative dielectric anisotropy were interposed.

Examples 27 to 29

[0097] A liquid crystal display device of Example 27 was produced in the same manner as in Example 1 by interposing the liquid crystals having negative dielectric anisotropy indicated in Table 9; a liquid crystal display device of Example 28 was produced in the same manner as in Example 1; and a liquid crystal display device of Example 29 was produced in the same manner as in Example 1.

TABLE 9

	Example 27	Example 28	Example 29
3-Cy-Ph5-O4	9	10	11
3O-Ph5-Ph5-O2	8		
5-Cy-Ph5-O4	9	10	11
0d1-Cy-Cy-5	5		
0d1-O-Cy-Cy-Ph5-1		10	
0d2-Cy-Cy-Ph5-O2	10		
0d2-O-Cy-Cy-Ph5-1		10	
1d2-O-Cy-Cy-Ph5-1		8	
2-Cy-Cy-Ph5-1	11	12	12
2-Cy-Cy-Ph5-O2	9	10	9
3-Cy-Cb1-Ph5-O2			4
3-Cy-Cy-Ph5-1	10	11	12
3-Cy-Cy-Ph5-O2	10	10	9
3-O-Cy-Cy-Ph5-O2	10		
5-Cy-Cb1-Ph5-O2			6
5-Cy-Cb-Ph5-O2			18
5-Cy-Cy-Ph5-O2	9	9	8
Sum of composition ratios (%)	100	100	100
Tni/° C.	101.2	103.9	118.1
Δn (20°)	0.100	0.098	0.105
ne (20° C.)	1.581	1.579	1.586
Δε (20° C.)	-7.5	-5.5	-6.4
ε⊥ (20° C.)	11.9	9.5	10.4
K3/K1 (20° C.)	1.08	1.16	1.05
K1/pN (20° C.)	15.8	16.5	20.2
Vsat/V (25° C.)	2.31	2.83	2.68
τr + d/msec (25° C., 6 V)	7.1	6.3	7.0

[0098] The liquid crystal display devices of Examples 27 to 29 realized higher response speeds, larger amounts of light transmission, a reduction in light leakage caused by external pressure, wider viewing angles, and higher contrast ratios, as compared with conventional VA liquid crystal display devices in which the same liquid crystals having negative dielectric anisotropy were interposed.

Examples 30 to 32

[0099] A liquid crystal display device of Example 30 was produced in the same manner as in Example 1 by interposing the liquid crystals having negative dielectric anisotropy indicated in Table 10; a liquid crystal display device of Example 31 was produced in the same manner as in Example 1; and a liquid crystal display device of Example 32 was produced in the same manner as in Example 1.

TABLE 10

	Example 30	Example 31	Example 32
3-Cy-Ph5-O4	16	16	16
5-Cy-Ph5-O2	12	16	16
0d1-Cy-Cy-5	7	4	10
0d3-Ph-Ph-1	11	10	10
1d1-Cy-Cy-3	9	8	
2-Cy-Ph-Ph5-O2	13	12	12

TABLE 10-continued

	Example 30	Example 31	Example 32
3-Cy-Cy-Ph5-O2	6	7	10
3-Cy-Ph-Ph5-O2	12	12	12
0d1-Cy-Cy-Ph-1	4	4	4
3-Cy-Ph-Ph-2	10	11	10
Sum of composition ratios	100	100	100
T _{ni} /° C.	80.2	80.3	80.9
Δn (20°)	0.128	0.129	0.126
n _e (20° C.)	1.492	1.491	1.491
Δε (20° C.)	-3.3	-3.5	-3.7
ε _L (20° C.)	6.8	7.1	7.4
K3/K1 (20° C.)	0.99	1.01	1.04
K1/pN (20° C.)	16.7	15.2	16.4
V _{sat} /V (25° C.)	5.27	5.16	4.98
τ _r + d/msec (25° C., 6 V)	4.7	4.8	5.2

[0100] The liquid crystal display devices of Examples 30 to 32 realized higher response speeds, larger amounts of light transmission, a reduction in light leakage caused by external pressure, wider viewing angles, and higher contrast ratios, as compared with conventional VA liquid crystal display devices in which the same liquid crystals having negative dielectric anisotropy were interposed.

What is claimed is:

1. A liquid crystal display device comprising:

a first substrate;

a second substrate; and

a liquid crystal composition layer having negative dielectric anisotropy that is interposed between the first substrate and the second substrate, the liquid crystal display device having a plurality of pixels, with each of the pixels being independently controllable, the pixel comprising a pair of a pixel electrode and a common electrode, the two electrodes being provided on at least one substrate between the first and second substrates, and the long axis of the liquid crystal molecules in the liquid crystal composition layer being in a substantial vertical alignment or a hybrid alignment.

2. The liquid crystal display device according to claim 1, wherein the distance between the pixel electrode and the common electrode (d_{gap} , μm) is smaller than the width of the pixel electrode or the common electrode (d_{ITO} , μm).

3. The liquid crystal display device according to claim 2, wherein as the liquid crystal composition layer, a liquid crystal composition comprising two or more kinds of compounds selected from the group of compounds represented by General Formula (LC1) to General Formula (LC5):

[Chemical Formula 1]

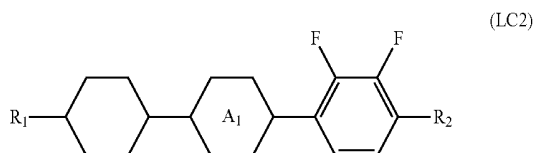
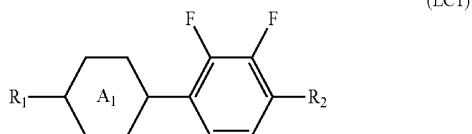

-continued

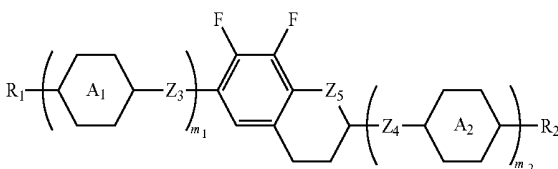
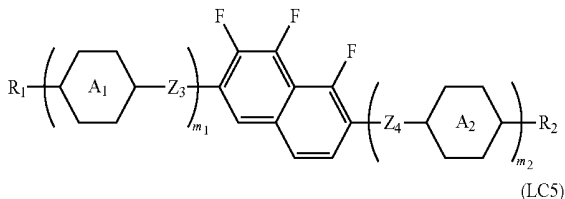
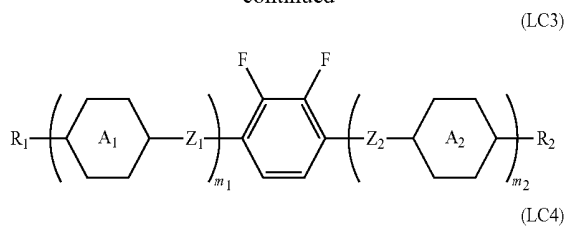

wherein R₁ and R₂ each independently represent an alkyl group having 1 to 15 carbon atoms; one or two or more CH₂ groups in the alkyl group are substituted by —O—, —CH=CH—, —CO—, —OCO—, —COO—, —C≡C—, —CF₂O— or —OCF₂— such that O atoms are not directly adjacent to each other; one or two or more H atoms in the alkyl group may be optionally substituted by halogen; A₁ and A₂ each independently represent any one of the following structures:

[Chemical Formula 2]

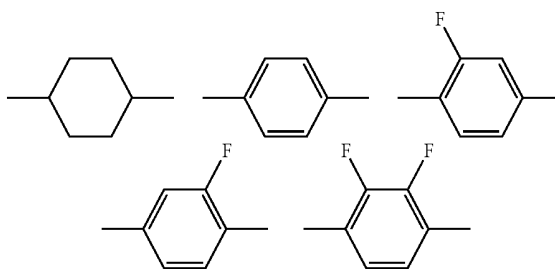

(wherein one or two or more CH₂ groups of the cyclohexane ring in the structures may be substituted by O atoms; one or two or more CH groups of the benzene ring in the structures may be substituted by N atoms; and one or two or more H atoms may be substituted by Cl, CF₃ or OCF₃); Z₁ to Z₄ each independently represent a single bond, —CH=CH—, —C≡C—, —CH₂CH₂—, —(CH₂)₄—, —COO—, —OCH₂—, —CH₂O—, —OCF₂— or —CF₂O—, while at least one of Z₁ and Z₂ is not a single bond; Z₅ represents a CH₂ group or an O atom; m₁ and m₂ each independently represent 0 to 3, and m₁+m₂ is 1, 2 or 3.

4. The liquid crystal display device according to claim 3, wherein as the liquid crystal composition layer, a liquid crystal composition comprising one kind or two or more kinds of compounds represented by General Formula (LC6):

[Chemical Formula 3]

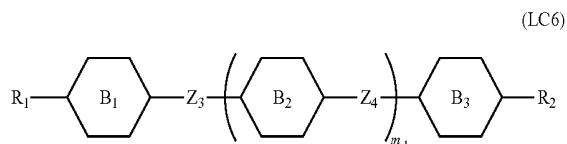

wherein R_1 and R_2 each independently represent an alkyl group having 1 to 15 carbon atoms; one or two or more CH_2 groups in the alkyl group may be substituted by $-\text{O}-$, $-\text{CH}=\text{CH}-$, $-\text{CO}-$, $-\text{OCO}-$, $-\text{COO}-$, $-\text{C}\equiv\text{C}-$, $-\text{CF}_2\text{O}-$ or $-\text{OCF}_2-$ such that O atoms are not directly adjacent to each other; one or two or more H atoms in the alkyl group may be optionally substituted by halogen; B_1 to B_3 each independently represent any one of the following:

[Chemical Formula 4]

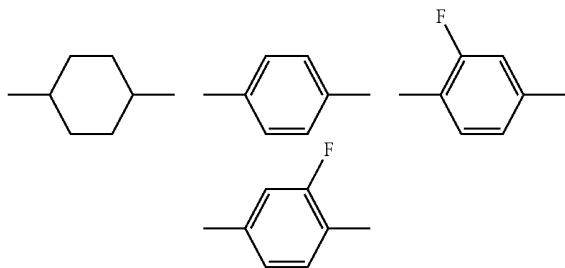

(wherein one or two or more CH_2CH_2 groups in the cyclohexane ring are substituted by $-\text{CH}=\text{CH}-$, $-\text{CF}_2\text{O}-$, or $-\text{OCF}_2-$; and one or two or more CH groups in the benzene ring may be substituted by N atoms); Z_3 and Z_4 each independently represent a single bond, $-\text{CH}=\text{CH}-$, $-\text{C}\equiv\text{C}-$, $-\text{CH}_2\text{CH}_2-$, $-(\text{CH}_2)_4-$, $-\text{COO}-$, $-\text{OCH}_2-$, $-\text{CH}_2\text{O}-$, $-\text{OCF}_2-$ or $-\text{CF}_2\text{O}-$; at least one of Z_1 and Z_2 is not a single bond; and m_1 represents 0 to 3.

5. The liquid crystal display device according to claim 3, wherein the compound of General Formula (LC2) is one kind or two or more kinds of compounds selected from the group consisting of compounds represented by the following General Formula (LC2)-1 to General Formula (LC2)-3:

[Chemical Formula 5]

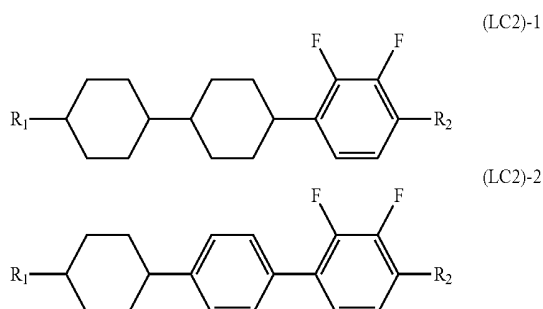

-continued

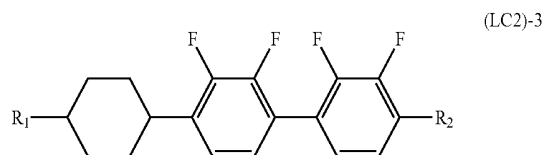

6. The liquid crystal display device according to claim 3, wherein the compound of General Formula (LC3) is one kind or two or more kinds of compounds selected from the group consisting of compounds represented by the following General Formula (LC3)-1 to General Formula (LC3)-13:

[Chemical Formula 6]

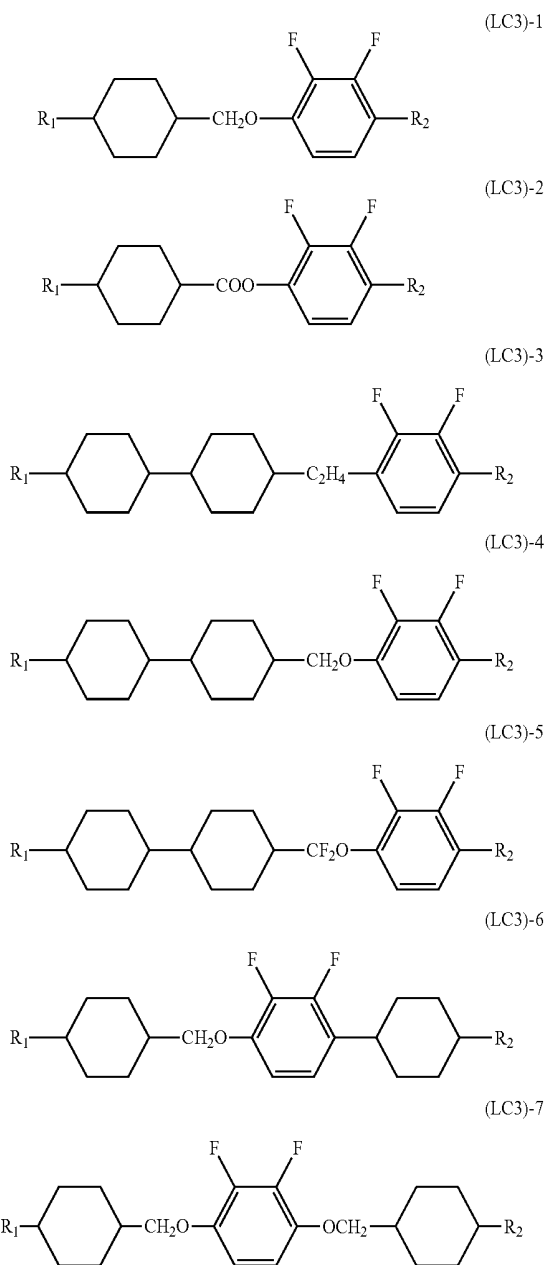

-continued

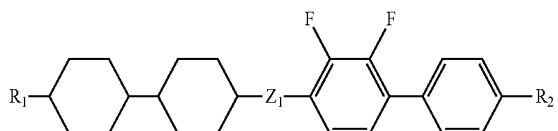
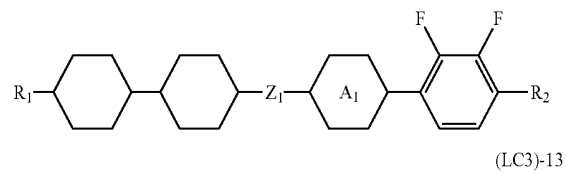
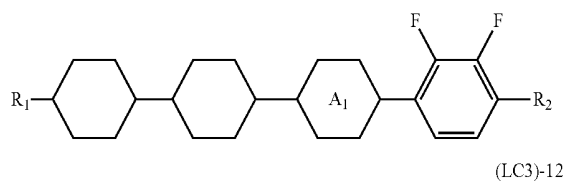
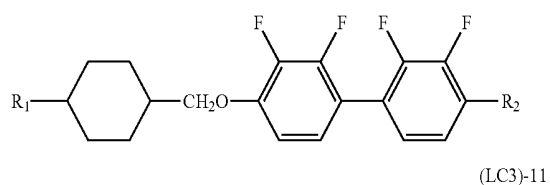
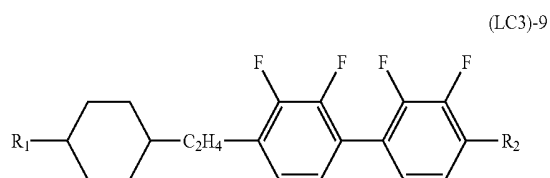
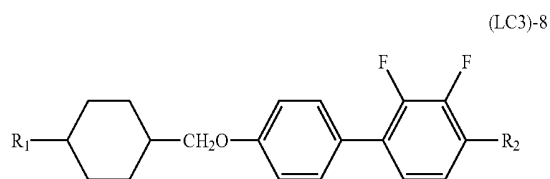

7. The liquid crystal display device according to claim 3, wherein the compound of General Formula (LC4) is one kind or two or more kinds of compounds selected from the group consisting of compounds represented by the following General Formula (LC4)-1 to General Formula (LC4)-6, and the compound General Formula (LC5) is one kind or two or more kinds of compounds selected from the group consisting of compounds represented by the following General Formula (LC5)-1 to General Formula (LC5)-4:

[Chemical Formula 7]

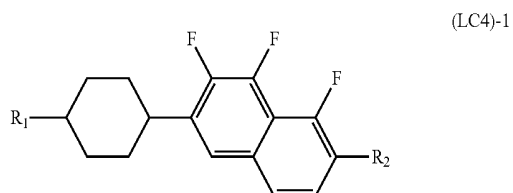

-continued

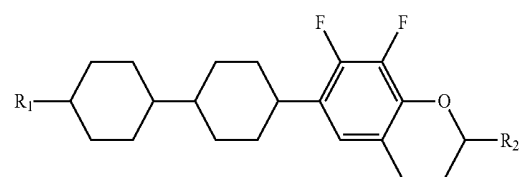
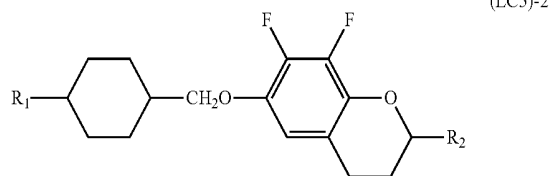
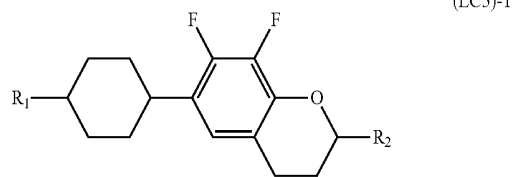
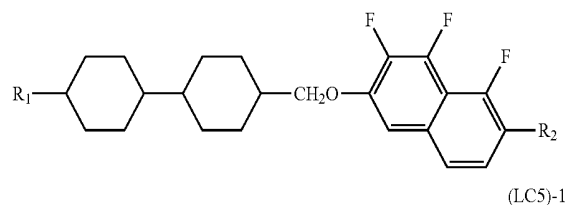
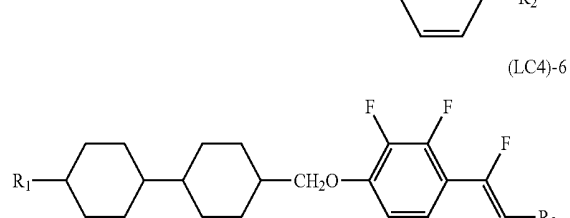
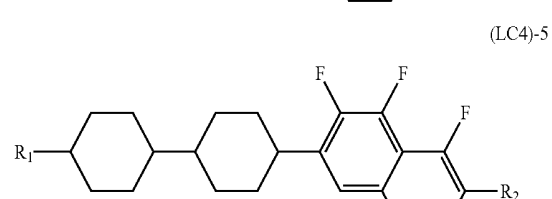
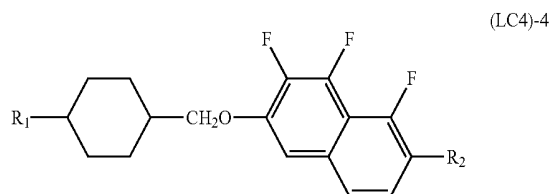
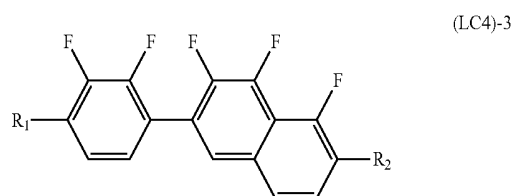
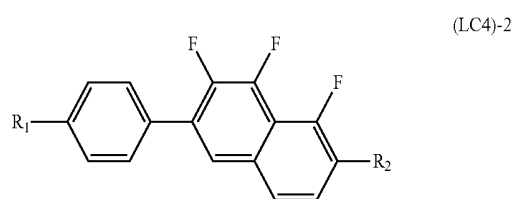

-continued

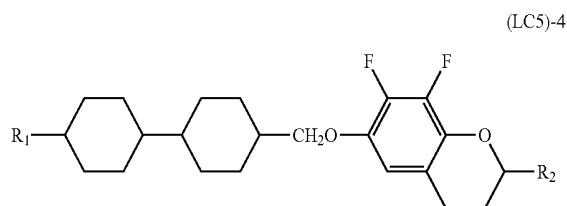

-continued

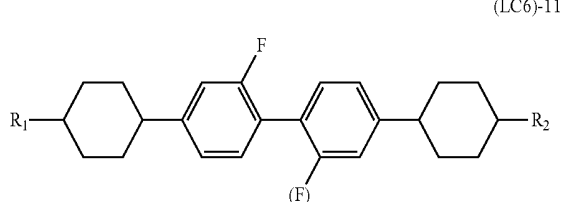

8. The liquid crystal display device according to claim 4, wherein the compound of General Formula (LC6) is one kind or two or more kinds of compounds selected from the group consisting of compounds represented by General Formula (LC6)-1 to General Formula (LC6)-11:

[Chemical Formula 8]

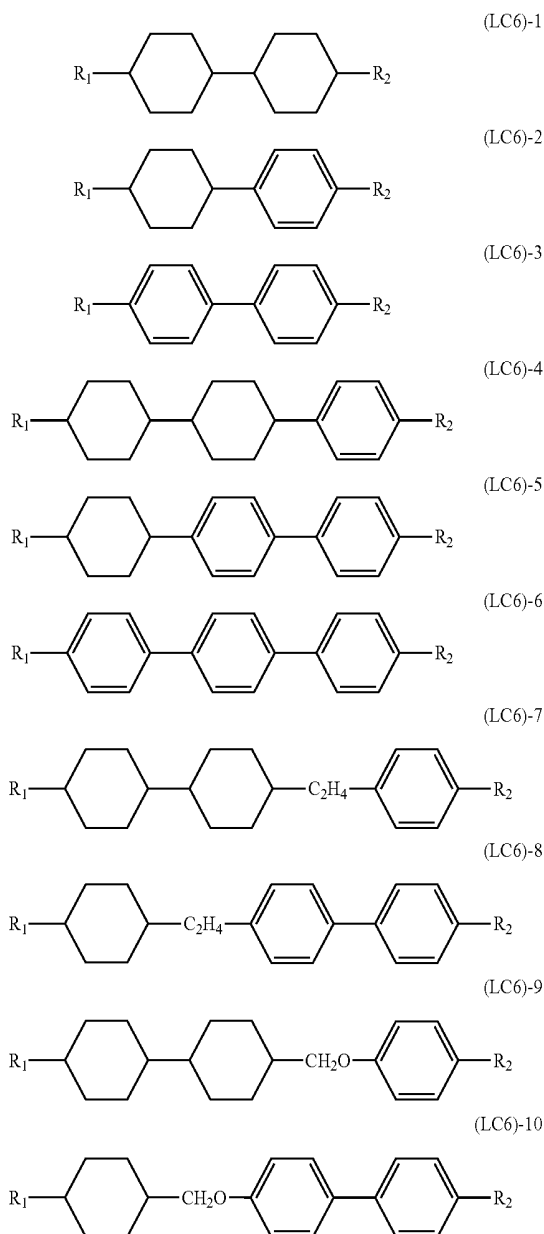

9. The liquid crystal display device according to claim 4 or 8, wherein the liquid crystal composition comprises 30% to 70% by mass of the compound represented by General Formula (LC6), and the viscosity η of the liquid crystal composition at 20° C. is 20 mPa·s or less.

10. The liquid crystal display device according to claim 6 or 7, wherein in General Formula (LC3)-1 to General Formula (LC3)-13, General Formula (LC4)-1 to General Formula (LC4)-6, and General Formula (LC5)-1 to General Formula (LC5)-4, at least one of Z_1 and Z_2 is $-C_2FO-$ or $-OCF_2-$.

11. The liquid crystal display device according to claim 3, wherein a liquid crystal composition comprising two or more kinds of compounds represented by General Formulas (LC1) to (LC5), in which $\Delta\epsilon$ is -4 or less, is used.

12. The liquid crystal display device according to any one of claims 3 to 12, wherein a liquid crystal composition comprising two or more kinds of compounds represented by General Formulas (LC1) to (LC5), in which $\Delta\epsilon$ is -4 or less, in an amount of 70% to 30% by mass, and comprising a compound represented by General Formula (LC6) in an amount of 30% to 70% by mass, is used.

13. The liquid crystal display device according to claim 4, wherein the liquid crystal composition comprises two or more kinds of compounds represented by General Formula (LC2) to (LC5), in which $\Delta\epsilon$ is -4 or less, in an amount of 70% to 30% by mass, and comprises a compound represented by General Formula (LC6) in an amount of 30% to 70% by mass.

14. The liquid crystal display device according to any one of claims 3 to 13, wherein a liquid crystal composition comprising one kind or two or more kinds of polymerizable compounds is used as the liquid crystal composition layer.

15. The liquid crystal display device according to claim 14, wherein the polymerizable compound is a disc-shaped liquid crystal compound having a structure in which a benzene derivative, a triphenylene derivative, a truxene derivative, a phthalocyanine derivative or a cyclohexane derivative serves as a parent nucleus at the center of the molecule, and a linear alkyl group, a linear alkoxy group or a substituted benzyloxy group is radially substituted as a side chain.

16. The liquid crystal display device according to claim 14, wherein the polymerizable compound is a polymerizable compound represented by General Formula (PC1):

[Chemical Formula 9]

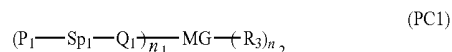

wherein P_1 represents a polymerizable functional group; Sp_1 represents a spacer group having 0 to 20 carbon atoms; Q_1 represents a single bond, $-O-$, $-NH-$, $-NHCO-$, $-CONH-$, $-CH=CH-$, $-CO-$, $-COO-$, $-OCO-$, $-OCOO-$, $-OOCO-$, $-CH=CH-$, $-CH=CH-COO-$, $-OCO-CH=CH-$ or $-C\equiv C-$; n_1 and n_2 each represent 1, 2 or 3; MG represents a mesogen group or a mesogenic supporting group; R_3 represents a halogen atom, a cyano group or an alkyl group having 1 to 25 carbon atoms; one or two or more CH_2 groups in the alkyl group may be substituted by $-O-$, $-S-$, $-NH-$, $-N(CH_3)-$, $-CO-$, $-COO-$, $-OCO-$, $-OCOO-$, $-SCO-$, $-COS-$ or $-C\equiv C-$ such that O atoms are not directly adjacent to each other; or R_3 represents $P_2-Sp_2-Q_2$ (wherein P_2 , Sp_2 and Q_2 have the same meanings as P_1 , Sp_1 and Q_1 , respectively).

17. The liquid crystal display device according to claim 16, wherein in General Formula (PC1), MG is represented by the following structure:

[Chemical Formula 10]

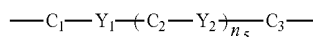

wherein C_1 to C_3 each independently represent a 1,4-phenylene group, a 1,4-cyclohexylene group, a 1,4-cyclohexenyl group, a tetrahydropyrane-2,5-diyl group, a 1,3-dioxane-2,5-diyl group, a tetrahydrothiopyrane-2,5-diyl group, a 1,4-bicyclo(2,2,2)octylene group, a decahydronaphthalene-2,6-diyl group, a pyridine-2,5-diyl group, a pyrimidine-2,5-diyl group, a pyrazine-2,5-diyl group, a 1,2,3,4-tetrahydronaphthalene-2,6-diyl group, a 2,6-naphthylene group, a phenanthrene-2,7-diyl group, a 9,10-dihydrophenanthrene-2,7-diyl group, a 1,2,3,4,4a,9,10a-octahydrophenanthrene-2,7-diyl group, or a fluorene-2,7-diyl group; the 1,4-phenylene group, 1,2,3,4-tetrahydronaphthalene-2,6-diyl group, 2,6-naphthylene group, phenanthrene-2,7-diyl group, 9,10-dihydrophenanthrene-2,7-diyl group, 1,2,3,4,4a,9,10a-octahydrophenanthrene-2,7-diyl group, and fluorene-2,7-diyl group may have, as substituents, one or more of F, Cl, CF_3 , OCF_3 , a cyano group, an alkyl group having 1 to 8 carbon atoms, an alkoxy group, an alkanoyl group, an alkanoyloxy group, an alkenyl group having 2 to 8 carbon atoms, an alkenyloxy group, an alkenoyl group or an alkenoyloxy group; Y_1 and Y_2 each independently represent $-COO-$, $-OCO-$, $-CH_2CH_2-$, $-OCH_2-$, $-CH_2O-$, $-CH=CH-$, $-C\equiv C-$, $-CH=CHCOO-$, $-OCOCH=CH-$, $-CH_2CH_2COO-$, $-CH_2CH_2OCO-$, $-COOCH_2CH_2-$, $-OCOCH_2CH_2-$, $-CONH-$, $-NHCO-$, or a single bond; and n_5 represents 0, 1 or 2.

18. The liquid crystal display device according to claim 16 or 17, wherein in General Formula (PC1), Sp_1 and Sp_2 each independently represent an alkylene group, the alkylene group may be substituted with one or more halogen atoms or CN, and one or two or more CH_2 groups present in the group may be substituted by $-O-$, $-S-$, $-NH-$, $-N(CH_3)-$, $-CO-$, $-COO-$, $-OCO-$, $-OCOO-$, $-SCO-$, $-COS-$ or $-C\equiv C-$ such that O atoms are not directly adjacent to each other.

19. The liquid crystal display device according to claim 16 or 17, wherein in General Formula (PC1), P_1 and P_2 each independently represent a structure selected from the group consisting of compounds represented by the following General Formula (PC1-a) to General Formula (PC1-d):

[Chemical Formula 11]

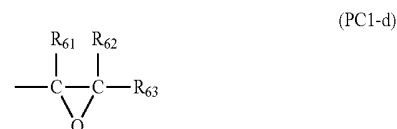
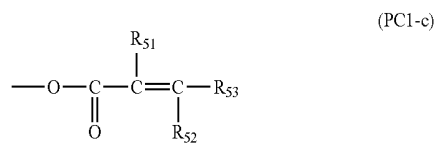
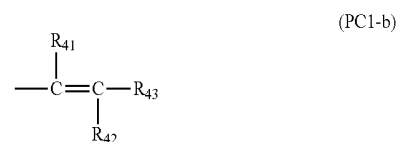
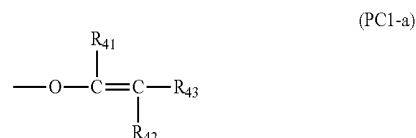

wherein R_{41} to R_{43} , R_{51} to R_{53} , and R_{61} to R_{63} each independently represent a hydrogen atom, a halogen atom, or an alkyl group having 1 to 5 carbon atoms.

20. The liquid crystal display device according to any one of claims 17 to 19, wherein the compound of General Formula (PC1) is a polymerizable compound represented by General Formula (PC1)-1 or General Formula (PC1)-2:

[Chemical Formula 12]

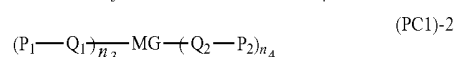
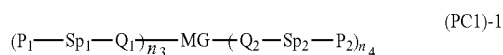

wherein P_1 , Sp_1 , Q_1 , P_2 , Sp_2 , Q_2 and MG have the same meanings as P_1 , Sp_1 , Q_1 , P_2 , Sp_2 , Q_2 and MG of General Formula (PC1), respectively; and n_3 and n_4 each independently represent 1, 2 or 3.

21. The liquid crystal display device according to any one of claims 16 to 20, wherein the compound of General Formula (PC1) is one kind or two or more kinds of compounds selected from the group consisting of compounds represented by General Formula (PC1)-3 to General Formula (PC1)-8:

[Chemical Formula 13]

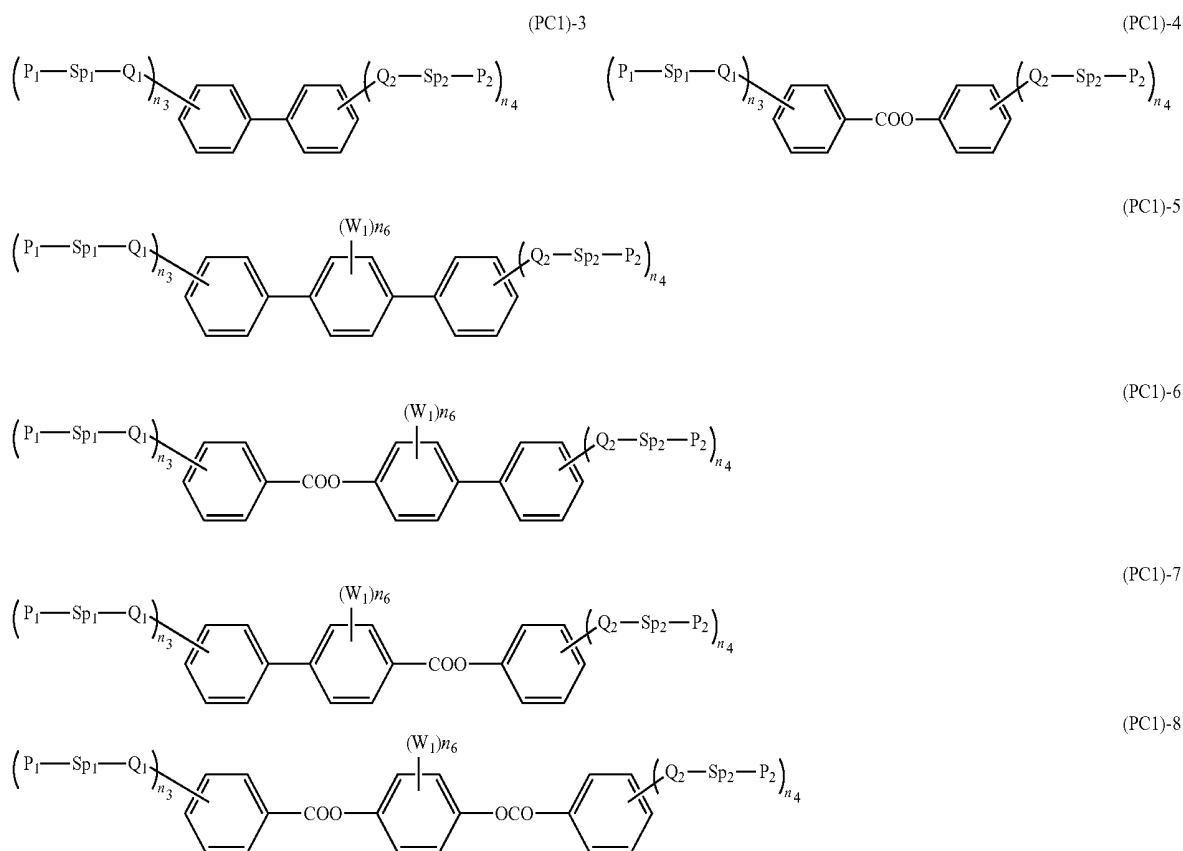

wherein W_1 each independently represents F, CF_3 , OCF_3 , CH_3 , OCH_3 , an alkyl group having 2 to 5 carbon atoms, an alkoxy group, an alkenyl group, $COOW_2$, $OCOW_2$ or $OCOOW_2$ (wherein W_2 represents a linear or branched alkyl group having 1 to 10 carbon atoms, or an alkenyl group having 2 to 5 carbon atoms); and n_6 represents 0, 1, 2, 3 or 4.

22. The liquid crystal display device according to any one of claims 16 to 21, wherein in General Formula (PC1) and General Formula (PC1)-1 to General Formula (PC1)-8, Sp_1 , Sp_2 , Q_1 and Q_2 are all single bonds.

23. The liquid crystal display device according to claim 21 or 22, wherein in General Formula (PC1)-1 to General Formula (PC1)-8, n_3+n_4 is from 3 to 6.

24. The liquid crystal display device according to any one of claims 19 to 23, wherein in General Formula (PC1) and General Formula (PC1)-1 to General Formula (PC1)-8, P_1 and P_2 represent General Formula (PC1-b).

25. The liquid crystal display device according to any one of claims 21 to 23, wherein in General Formula (PC1)-1 to General Formula (PC1)-8, W_1 represents F, CF_3 , OCF_3 , CH_3 or OCH_3 , and n_6 represents 1, 2, 3 or 4.

26. The liquid crystal display device according to claim 16, wherein a liquid crystal composition comprising one kind or two or more kinds of disc-shaped liquid crystal compounds represented by General (PC1) in which MG is represented by General Formula (PC1)-9:

[Chemical Formula 14]

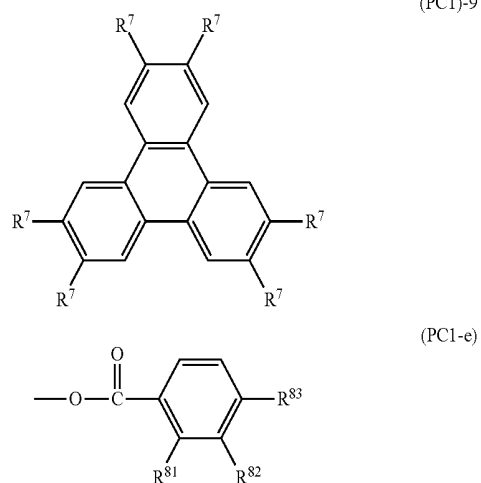

wherein R_7 each independently represents $P_1-Sp_1-Q_1$ or a substituent of General Formula (PC1-e) (wherein P_1 , Sp_1 and Q_1 have the same meanings as P_1 , Sp_1 and Q_1 of General Formula (PC1)); R_{81} and R_{82} each independently represent a hydrogen atom, a halogen atom or a methyl group; R_{83} represents an alkoxy group having 1 to 20 carbon atoms; and at

least one hydrogen atom in the alkoxy group is substituted by a substituent represented by any one of General Formulas (PC1-a) to (PC1-d):

[Chemical Formula 15]

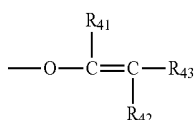

(PC1-a)

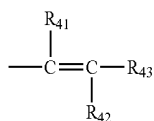

(PC1-b)

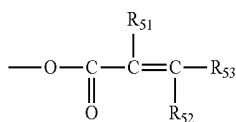

(PC1-c)

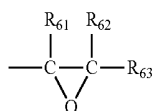

(PC1-d)

wherein R_{41} to R_{43} , R_{51} to R_{53} , and R_{61} to R_{63} each independently represent a hydrogen atom, a halogen atom, or an alkyl group having 1 to 5 carbon atoms.

27. The liquid crystal display device according to any one of claims 14 to 26, wherein the liquid crystal composition does not comprise a polymerization initiator.

28. The liquid crystal display device according to any one of claims 14 to 26, wherein the content of the polymerizable compound is 0.05% to 2.0% by mass.

29. The liquid crystal display device according to any one of claims 1 to 28, wherein the product ($\Delta n \cdot d$) of the refractive index anisotropy (Δn) of the liquid crystal composition and the distance (d) between the first substrate and the second substrate of the display device is 0.30 to 0.40.

30. The liquid crystal display device according to any one of claims 1 to 30, wherein an alignment film formed from a polyimide (PI), a polyamide, a chalcone, a cinnamate or a cinnamoyl is provided on each of the surfaces that are in contact with the liquid crystal composition on the first substrate and the second substrate of the display device.

31. The liquid crystal display device according to claim 30, wherein an alignment film produced by utilizing a photo-alignment technology is provided on each of the surfaces that are in contact with the liquid crystal composition on the first substrate and the second substrate of the display device.

32. The liquid crystal display device according to any one of claims 1 to 31, wherein the tilt angle of the liquid crystal composition on the substrate surface is 85° to 90° .

33. The liquid crystal display device according to any one of claims 1 to 31, wherein the tilt angle of the liquid crystal composition on any one substrate surface of the first substrate and the second substrate is 85° to 90° , and the tilt angle of the liquid crystal composition on the other substrate surface is 3° to 20° .

* * * * *

专利名称(译)	新型液晶显示装置和有用的液晶组合物		
公开(公告)号	US20130265527A1	公开(公告)日	2013-10-10
申请号	US13/825766	申请日	2011-09-22
[标]申请(专利权)人(译)	TAKEUCHI清史 KANEOKA MASAKAZU		
申请(专利权)人(译)	TAKEUCHI, 清史 KANEOKA, MASAKAZU		
当前申请(专利权)人(译)	DIC株式会社		
[标]发明人	TAKEUCHI KIYOFUMI KANEOKA MASAKAZU		
发明人	TAKEUCHI, KIYOFUMI KANEOKA, MASAKAZU		
IPC分类号	G02F1/1337		
CPC分类号	C09K19/3066 C09K2019/301 C09K19/3402 C09K19/42 C09K2019/0466 C09K2019/3037 C09K2019/304 C09K2019/3425 G02F1/134363 G02F2001/13712 G02F1/133711 G02F1/133723 C09K2019/3004 C09K2019/3009 C09K19/322 C09K2019/0448		
优先权	2010216912 2010-09-28 JP		
其他公开文献	US9389462		
外部链接	Espacenet USPTO		

摘要(译)

本发明提供一种VAIPS模式的液晶显示装置，其使用具有负介电各向异性 ($\Delta\epsilon < 0$) 的液晶材料，并且具有高响应速度，宽视角，透光时的高透射率，光线阻挡时的黑色水平较高，对比度极佳。本发明公开了一种液晶显示装置，包括第一基板，第二基板和介电常数为负的液晶组合物层，介于第一基板和第二基板之间，液晶显示装置为电光显示器在具有多个像素的装置中，每个像素可独立控制并具有一对像素电极和公共电极，两个电极设置在第一基板和第二基板的至少一个基板上，液晶组合物层的液晶分子的长轴相对于基板表面呈大致垂直取向或混合取向。

