



US 20140176869A1

(19) **United States**
(12) **Patent Application Publication**
LEE et al.

(10) **Pub. No.: US 2014/0176869 A1**
(43) **Pub. Date: Jun. 26, 2014**

(54) **LIQUID CRYSTAL DISPLAY DEVICE**
(71) Applicant: **LG Display Co., Ltd.**, Seoul (KR)

(52) **U.S. Cl.**
CPC **G02F 1/133615** (2013.01)
USPC **349/65**

(72) Inventors: **Jun-Jae LEE**, Paju-si (KR); **Su-Young AN**, Goyang-si (KR); **Chin-Il PARK**, Paju-si (KR)

(57) **ABSTRACT**

(73) Assignee: **LG Display Co., Ltd.**, Seoul (KR)

An LCD device includes a liquid crystal panel; a backlight unit disposed at a rear side of the liquid crystal panel and including an LED assembly and a light guide plate, wherein the light guide plate has a first surface facing the LED assembly and a second surface opposite to the first surface; a cover bottom including a horizontal plane over which the backlight unit is disposed and a side perpendicular to the horizontal plane; a guide panel including a side wall and a horizontal portion, wherein the side wall has a first vertical portion surrounding an outer surface of the side of the cover bottom, and the horizontal portion is vertically bent from the first vertical portion and supports the liquid crystal panel, wherein at least one elastic stopper is formed at the side wall and contacts the second surface.

(21) Appl. No.: **14/075,312**

(22) Filed: **Nov. 8, 2013**

(30) **Foreign Application Priority Data**

Dec. 24, 2012 (KR) 10-2012-0151797
Sep. 26, 2013 (KR) 10-2013-0114455

Publication Classification

(51) **Int. Cl.**
G02F 1/1335 (2006.01)

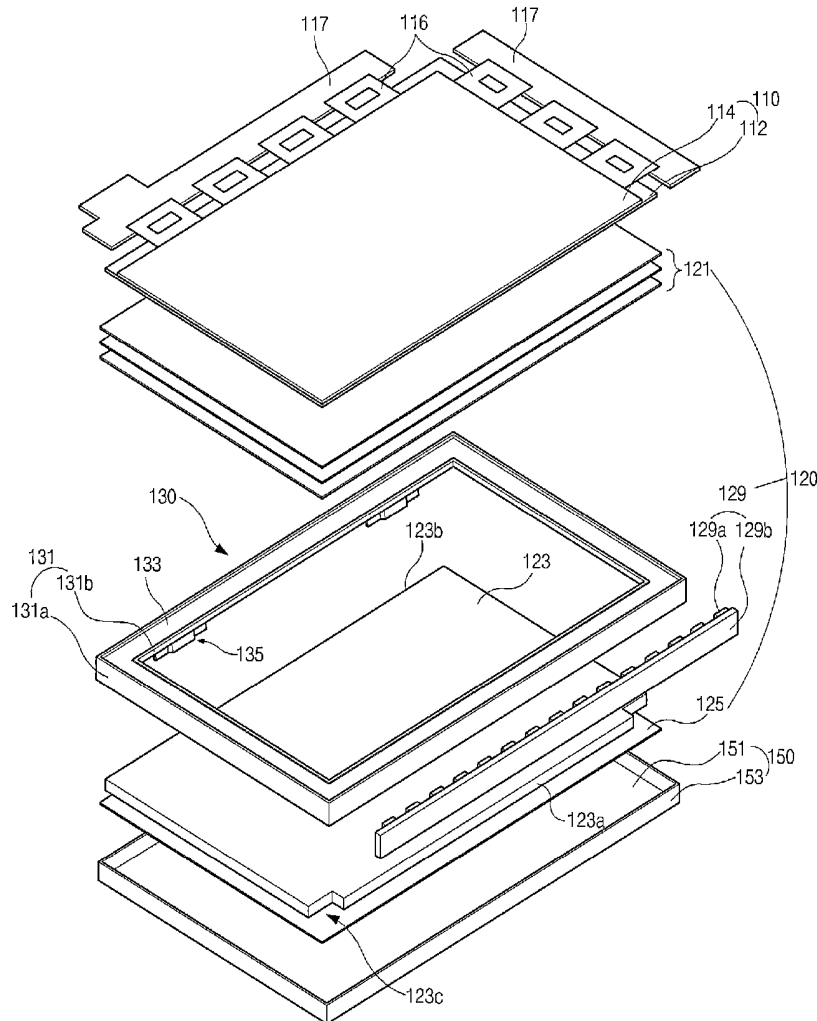

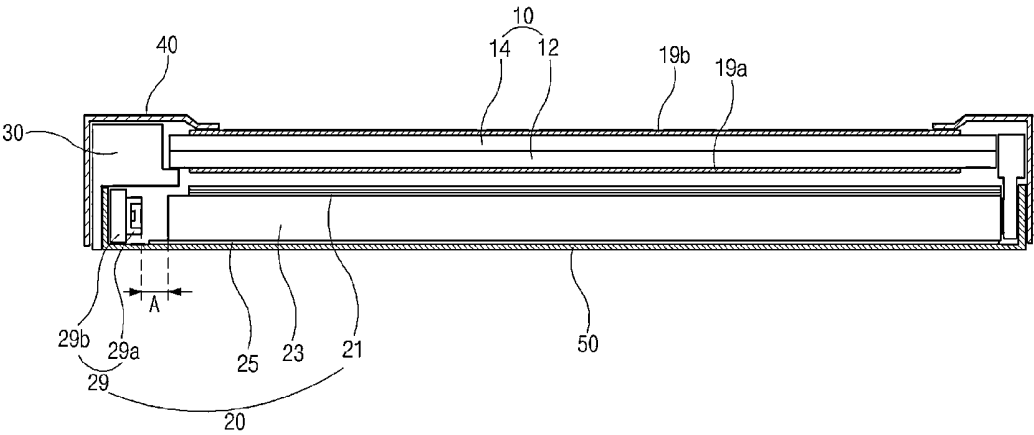

FIG. 1
Related Art

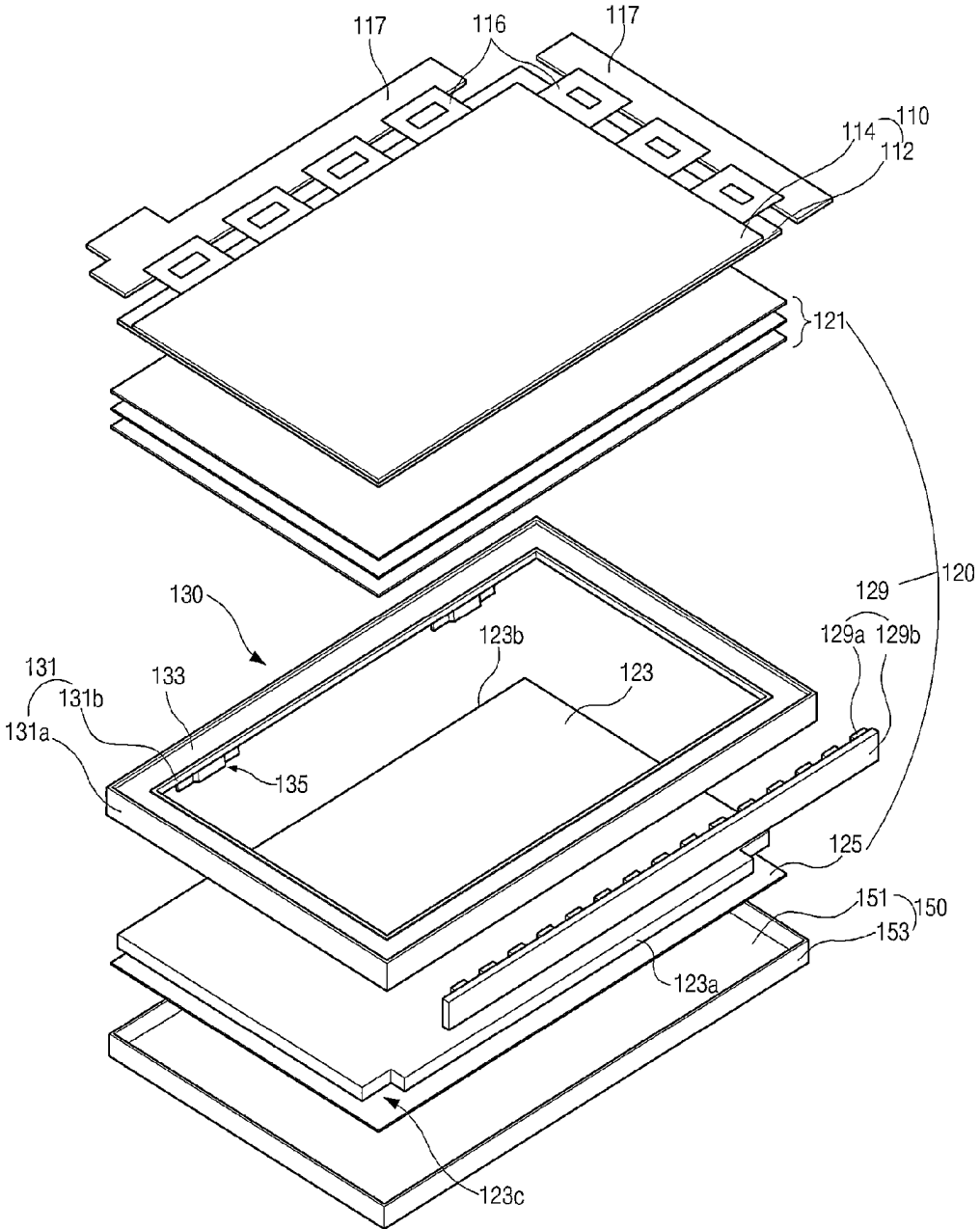

FIG. 2

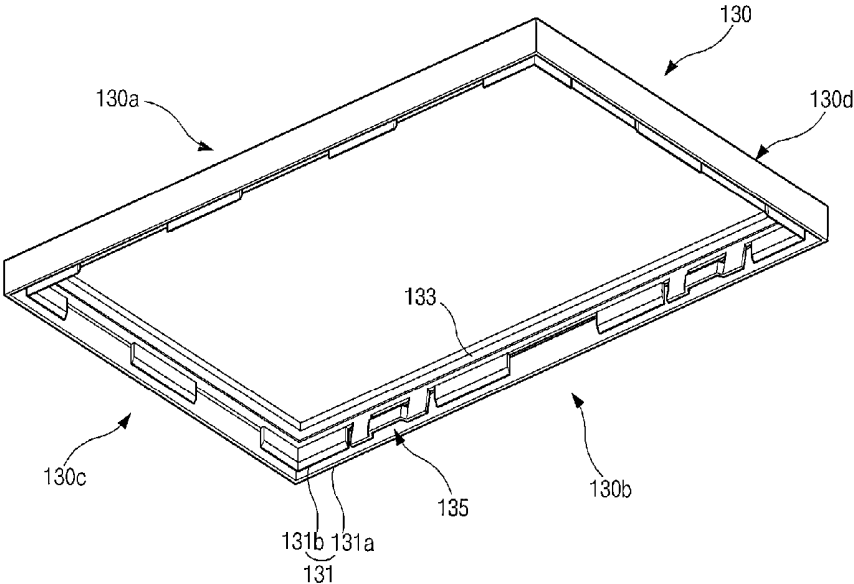

FIG. 3A

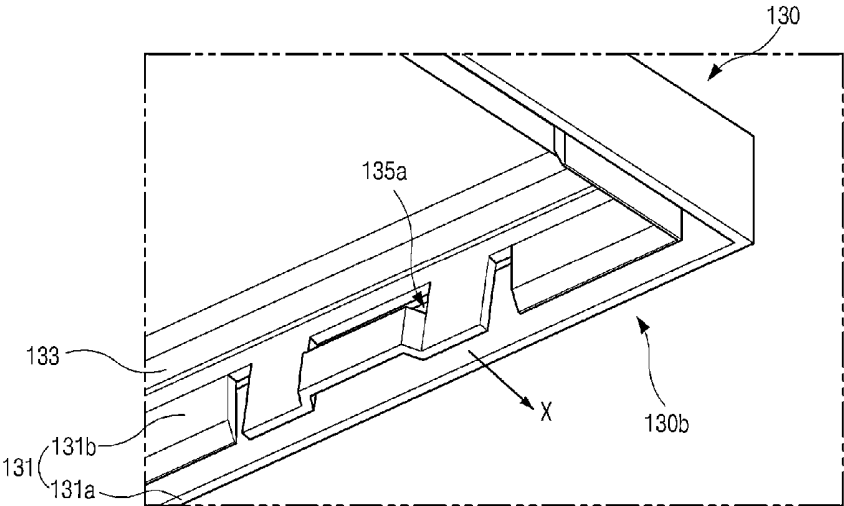

FIG. 3B

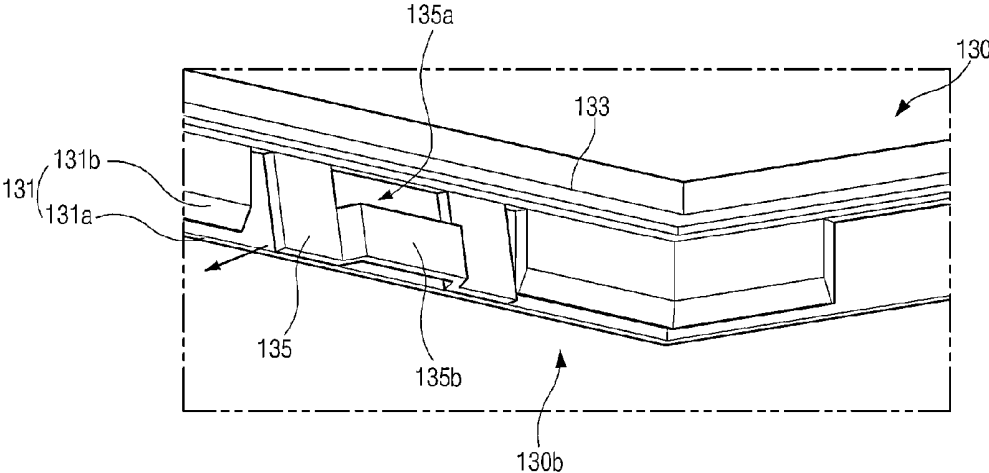

FIG. 3C

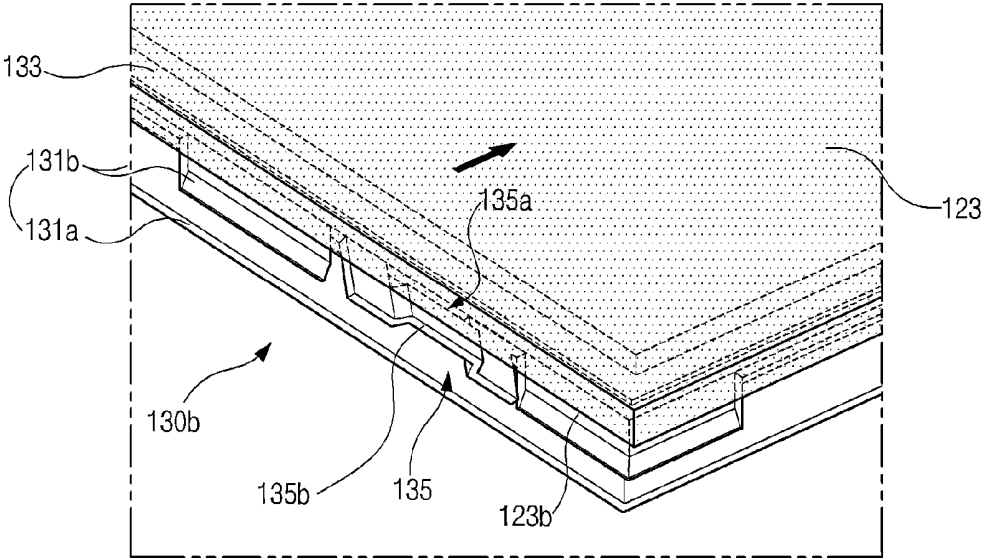

FIG. 3D

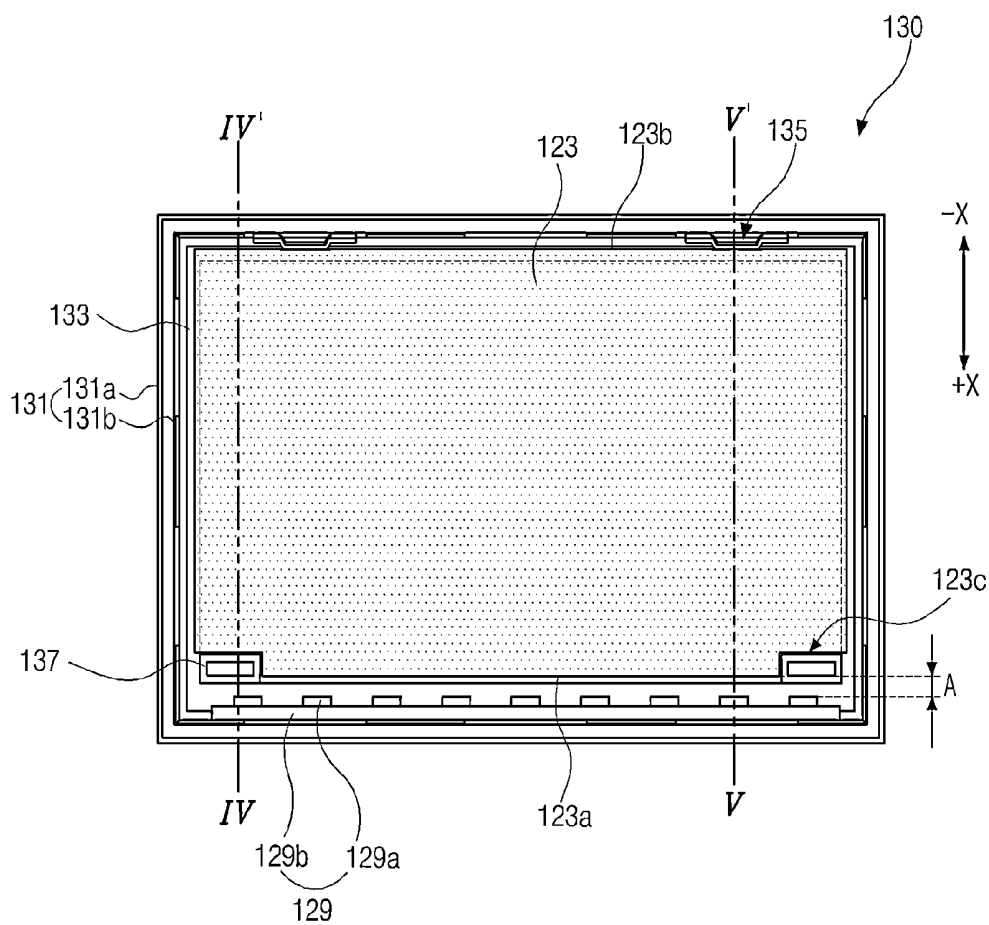

FIG. 4A

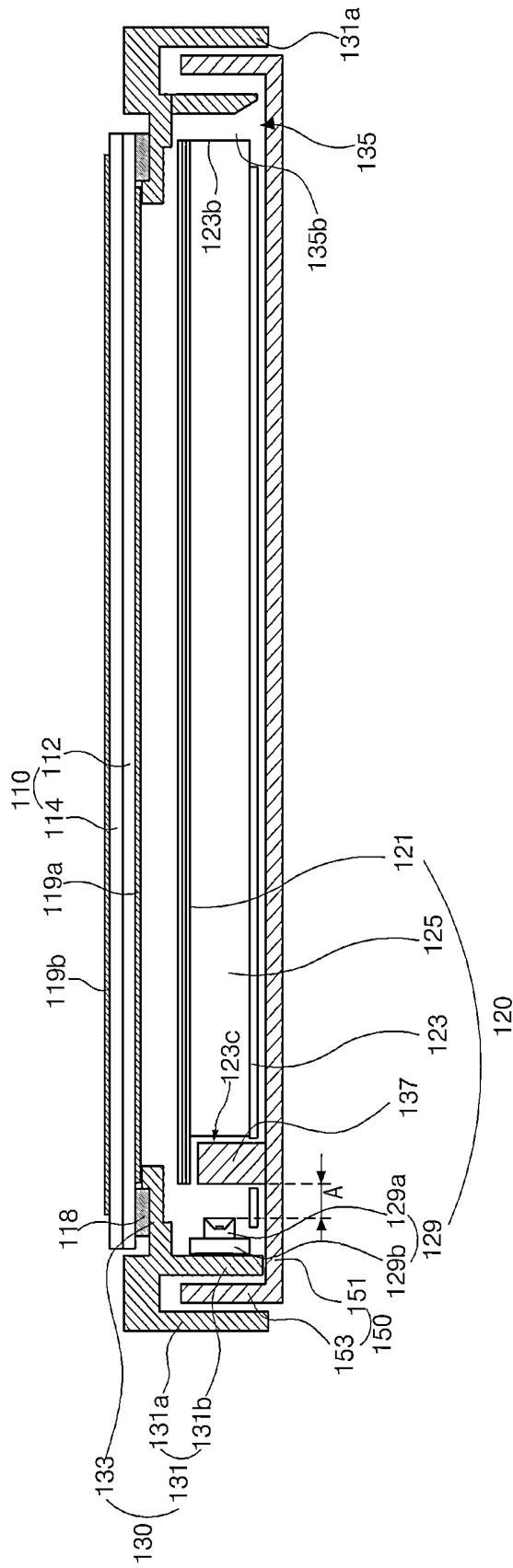

FIG. 4B

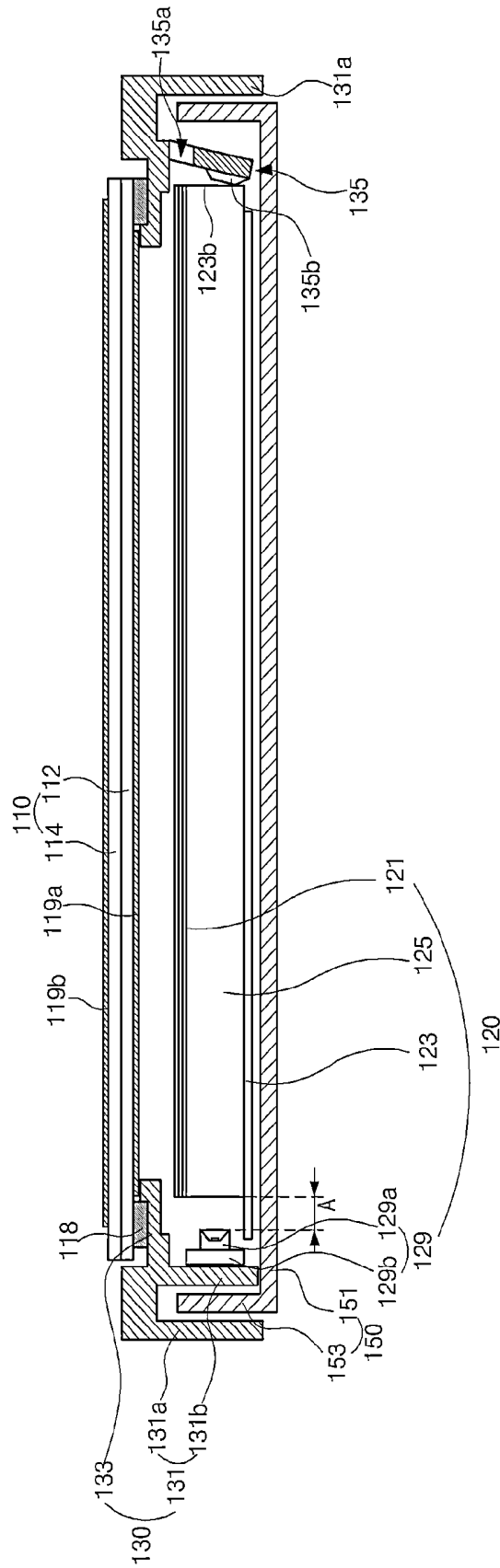

FIG. 5A

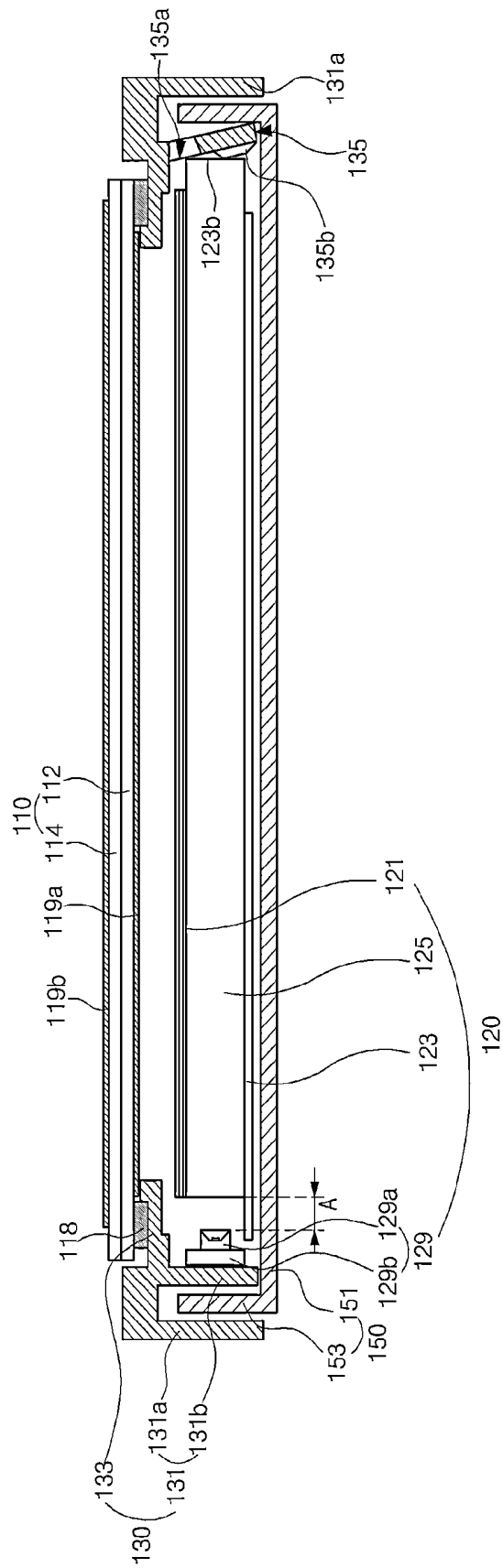

FIG. 5B

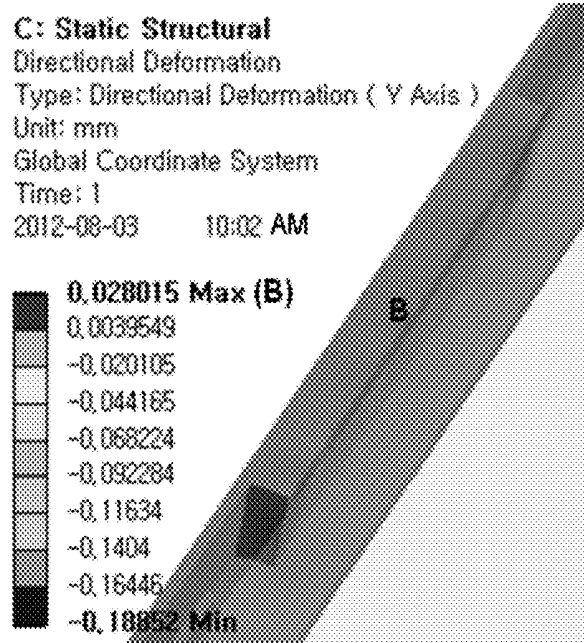

FIG. 6A

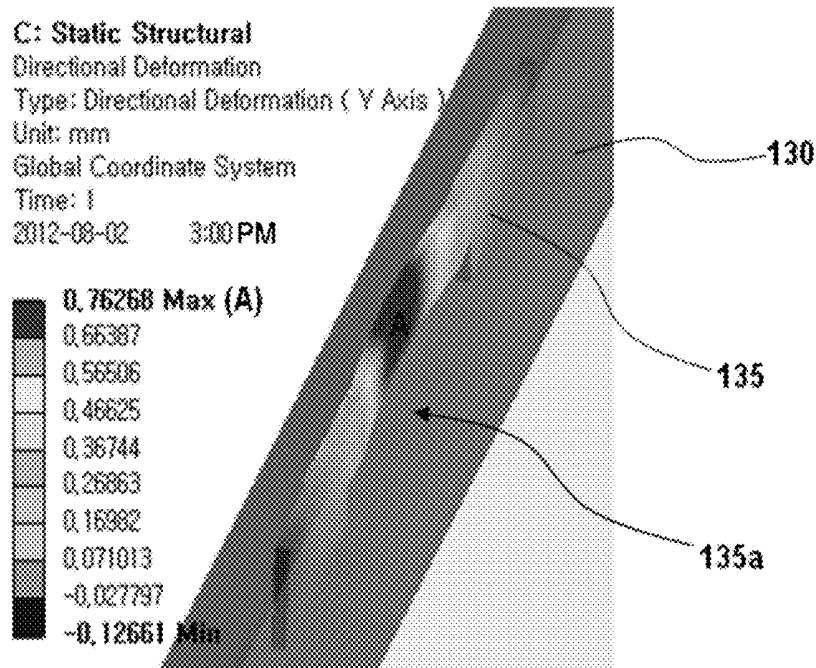

FIG. 6B

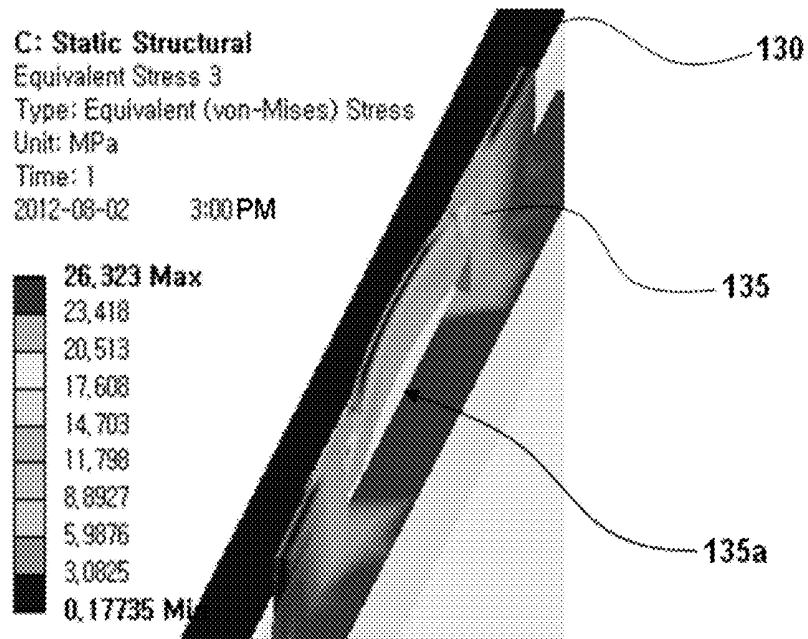

FIG. 6C

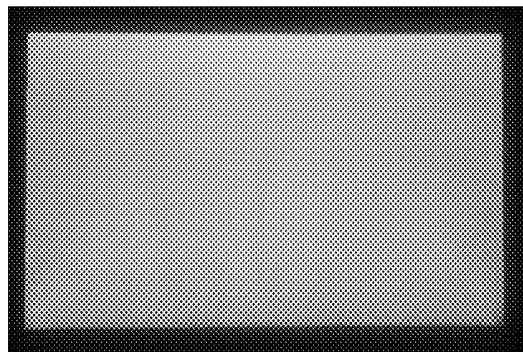

FIG. 7A

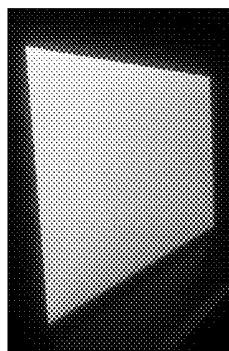

FIG. 7B

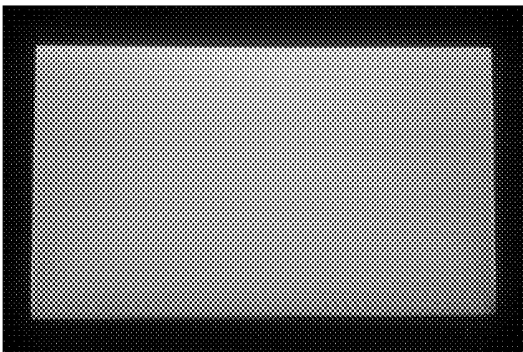

FIG. 7C

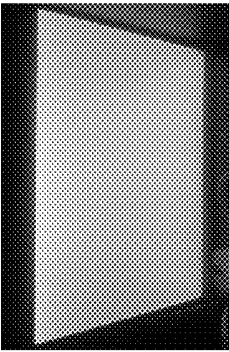

FIG. 7D

LIQUID CRYSTAL DISPLAY DEVICE

[0001] The application claims the benefit of Korean Patent Application No. 10-2012-0151797 filed in Korea on Dec. 24, 2012 and Korean Patent Application No. 10-2013-0114455 filed in Korea on Sep. 26, 2013, each of which is hereby incorporated by reference for all purposes as if fully set forth herein.

BACKGROUND

[0002] 1. Field of the Disclosure

[0003] The disclosure relates to a liquid crystal display device, and more particularly, to a liquid crystal display device having a narrow bezel and an increase in brightness and image qualities.

[0004] 2. Discussion of the Related Art

[0005] Liquid crystal display (LCD) devices are most widely used for monitors of notebook computers, monitors of personal computers and televisions due to excellent moving images and high contrast ratio. LCD devices use the optical anisotropy and polarization properties of liquid crystal molecules of a liquid crystal layer to produce an image.

[0006] An LCD device includes two substrates spaced apart from and facing each other and a liquid crystal layer interposed between the two substrates. The alignment direction of the liquid crystal molecules is controlled by varying the intensity of an electric field applied to the liquid crystal layer, and the transmittance of light through the liquid crystal layer is changed.

[0007] The LCD devices require an additional light source because the LCD devices are not self-luminescent. Therefore, a backlight unit is disposed at a rear side of a liquid crystal (LC) panel and emits light into the LC panel, whereby discernible images can be displayed.

[0008] Backlight units include cold cathode fluorescent lamps (CCFLs), external electrode fluorescent lamps (EEFLs), and light emitting diodes (LEDs) as a light source. Among these, LEDs have been widely used due to their small sizes, low power consumption, and high reliability.

[0009] Backlight units are in general classified as edge type or direct type according to the position of the light source with respect to a display panel. In edge-type backlight units, one or a pair of lamps are disposed at one side or at each of two sides of a light guide plate of a backlight unit. In direct-type backlight units, a plurality of lamps is disposed directly under the display panel.

[0010] The direct-type backlight units have restrictions on decreasing a thickness of an LCD device, and the direct-type backlight units are widely used for LCD devices that focus on brightness rather than a thickness of a screen. The edge-type backlight units can have lighter weights and thinner thicknesses than the direct-type, and the edge-type backlight units are widely used for LCD devices that focus on thicknesses such as monitors of notebook computers or personal computers.

[0011] FIG. 1 is a cross-sectional view of illustrating an LCD device including an edge-type backlight unit using LEDs as a light source according to the related art.

[0012] In FIG. 1, the related art LCD device includes a liquid crystal panel 10, an edge-type backlight unit 20, a guide panel 30, a top cover 40 and a cover bottom 50.

[0013] The liquid crystal panel 10 displays images and includes first and second substrates 12 and 14 facing and attached to each other with a liquid crystal layer (not shown) interposed therebetween.

[0014] Polarizers 19a and 19b are attached at front and rear surfaces of the liquid crystal panel 10, respectively, and control the polarization of light.

[0015] The backlight unit 20 is disposed at a rear side of the liquid crystal panel 10. The backlight unit 20 includes an LED assembly 29, a reflection sheet 25, a light guide plate 23 and a plurality of optical sheets 21. The LED assembly 29 is disposed at an edge of at least one side of the guide panel 30 along a length direction of the guide panel 30, and includes LEDs 29a and a printed circuit board (PCB) 29b on which the LEDs 29a are mounted. The reflection sheet 25 is disposed over the cover bottom 50 and is white- or silver-colored. The light guide plate 23 is disposed over the reflection sheet 25. The plurality of optical sheets 21 is disposed over the light guide plate 23.

[0016] Edges of the liquid crystal panel 10 and the backlight unit 20 are surrounded by the guide panel 30 having a rectangular frame shape. The top cover 40 covers edges of a front surface of the liquid crystal panel 10, and the cover bottom 50 covers a rear surface of the backlight unit 20. The top cover 40 and the cover bottom 50 are combined with the guide panel 30 to thereby constitute one-united body.

[0017] Various optical designs are considered to provide a surface light source from the backlight unit 20 of the LCD device to the liquid crystal panel 10. Among these, maintaining an optical gap A between the light guide plate 23 and the LED assembly 29 is a significant factor.

[0018] However, when an LCD device having light weight, slim thickness and narrow bezel, which is recently required, is embodied, light leakage may occur because additional elements for preventing movement of the light guide plate 23 are near by an active area where an image is displayed. To prevent the light leakage, the additional elements may be removed, and in this case, it is difficult to maintain the optical gap A between the light guide plate 23 and the LED assembly 29.

[0019] Thus, it is not easy to provide high surface light source to the liquid crystal panel 10. In particular, there may occur light leakage between the light guide plate 23 and the LED assembly 29 or the LED assembly may be damaged by movement of the light guide plate 23.

[0020] Therefore, problems of lowering qualities of the LCD device such as decreases in brightness and image qualities are caused.

SUMMARY

[0021] Accordingly, the present invention is directed to a liquid crystal display device that substantially obviates one or more of the problems due to limitations and disadvantages of the related art.

[0022] An advantage of the present invention is to provide a liquid crystal display device that prevents a light guide plate from being moved and light from being leaked.

[0023] Another advantage of the present invention is to provide a liquid crystal display device having improvement in brightness and image qualities.

[0024] Another advantage of the present invention is to provide a liquid crystal display device having light weight, slim thickness and narrow bezel.

[0025] To achieve these and other advantages and in accordance with the purpose of embodiments of the invention, as embodied and broadly described,

BRIEF DESCRIPTION OF THE DRAWINGS

[0026] FIG. 1 is a cross-sectional view of an LCD device including an edge-type backlight unit using LEDs as a light source according to the related art;

[0027] FIG. 2 is an exploded perspective view of an LCD device according to an embodiment of the present invention;

[0028] FIG. 3A is a perspective view of a guide panel of an embodiment of the present invention;

[0029] FIGS. 3B to 3D are views enlarging a part of the guide panel of FIG. 3A;

[0030] FIG. 4A is a plan view of a guide panel and a light guide plate according to an embodiment of the present invention;

[0031] FIG. 4B is a cross-sectional view of a modularized LCD device of FIG. 2 taken along the line IV-IV' of FIG. 4A;

[0032] FIGS. 5A and 5B are cross-sectional views of a modularized LCD device of FIG. 2 taken along the line V-V' of FIG. 4A;

[0033] FIG. 6A and FIG. 6B are simulation results of measuring an amount of deformation of a guide panel depending on an elastic stopper with or without a hole according to the embodiment of the present invention, and FIG. 6C is a simulation result of measuring tensile strength of an elastic stopper; and

[0034] FIGS. 7A to 7D are simulation results of measuring light leakage when an LCD device according to the present invention is driven under different temperatures.

DETAILED DESCRIPTION OF THE PREFERRED EMBODIMENTS

[0035] Reference will now be made in detail to embodiments of the present invention, examples of which are illustrated in the accompanying drawings.

[0036] FIG. 2 is an exploded perspective view of an LCD device according to an embodiment of the present invention.

[0037] In FIG. 2, an LCD device includes a liquid crystal panel 110 and a backlight unit 120 that lie one upon another and further includes a guide panel 130 and a cover bottom 150 to unite the liquid crystal panel 110 and the backlight unit 120.

[0038] Here, when a display surface of the liquid crystal panel 110 faces the front, the backlight unit 120 is disposed at the rear of the liquid crystal panel 110, the guide panel 130 having a rectangle frame shape surrounds the edges of the liquid crystal panel 110 and the backlight unit 120, and the cover bottom 150 closely disposed at the rear surface of the backlight unit 120 is united with the guide panel 130 to thereby form one-united body.

[0039] More particularly, the liquid crystal panel 110 displays images. The liquid crystal panel 110 includes first and second substrates 112 and 114 facing and attached to each other with a liquid crystal layer interposed there between. In an active matrix-type, although not shown in the figure, gate lines and data lines are formed on an inner surface of the first substrate 112, which may be referred to as a lower substrate or an array substrate. The gate lines and the data lines cross each other to define pixel regions. A thin film transistor (TFT) is formed at each crossing point of the gate and data lines, and a

pixel electrode is connected to the thin film transistor at each pixel region. The pixel electrode may be formed of a transparent conductive material.

[0040] A black matrix and red, green and blue color filter patterns are formed on an inner surface of the second substrate 114, which may be referred to as an upper substrate or a color filter substrate. The color filter patterns correspond to the pixel regions, respectively. The black matrix surrounds each of the color filter patterns and covers the gate lines, the data lines, and the thin film transistors. A transparent common electrode is formed over the color filter patterns and the black matrix.

[0041] Polarizers (not shown) are attached to outer surfaces of the first and second substrates 112 and 114 and selectively transmit linearly polarized light.

[0042] A printed circuit board 117 is attached to at least a side of the liquid crystal panel 110 via connecting means 116 such as flexible printed circuit boards or tape carrier packages (TCPs). The printed circuit board 117 is bent toward a side surface of the guide panel 130 or a rear surface of the cover bottom 150 during a module assembly process.

[0043] In the liquid crystal panel 110, on/off signals from gate driving circuits are provided to the thin film transistors through the gate lines, and when the thin film transistors selected by each gate line turn on, data signals from data driving circuits are provided to the pixel electrodes through the data lines. According to this signal voltage, an electric field is induced between the pixel electrodes and the common electrode, and the arrangement of the liquid crystal molecules is changed by the electric field to thereby change transmittance of light. Therefore, the liquid crystal panel 110 displays variances in the transmittance as images.

[0044] The backlight unit 120 is disposed under the liquid crystal panel 110 and provides light to the liquid crystal panel 110 so that the variances in the transmittance of the liquid crystal panel 110 are shown to the outside.

[0045] The backlight unit 120 includes a light-emitting diode (LED) assembly 129, a reflection sheet 125 of a white or silver color, a light guide plate 123 over the reflection sheet 125, and optical sheets 121 over the light guide plate 123.

[0046] The LED assembly 129, as a light source of the backlight unit 120, is disposed at a side of the light guide plate 123 such that the LED assembly 129 faces a side surface 123a of the light guide plate 123, which light is incident on and is referred to as a light-incident surface hereinafter. The LED assembly 129 includes a plurality of LEDs 129a and a printed circuit board (PCB) 129b on which the LEDs 129a are mounted to be spaced apart from each other.

[0047] The LEDs 129a include red (R), green (G) and blue (B) LEDs respectively emitting red, green and blue light toward the light-incident surface 123a of the light guide plate 123. White light is produced by lighting the RGB LEDs 129a up at a time and by mixing the red, green and blue light.

[0048] Alternatively, to increase luminous efficiency and brightness, the LEDs 129a may include a blue LED chip and use cerium-doped yttrium aluminum garnet (YAG:Ce) as a fluorescent substance. That is, the LEDs 129a may be a blue LED with a yellow fluorescent substance. When passing through the fluorescent, blue light emitted from the blue LED chip of the LEDs 129a is mixed with yellow light from the fluorescent, thereby producing white light.

[0049] The light guide plate 123 totally reflects light emitted from the LEDs 129a several times such that the light moves through the inside of the light guide plate 123 and are

uniformly scattered. Accordingly, an initial surface light source is provided to the liquid crystal panel 110.

[0050] The light guide plate 123 has high transparency, weatherability, and colorability, and the light guide plate 123 induces light to diffuse when the light passes through it.

[0051] The light guide plate 123 may be formed of a plastic material such as polymethylmethacrylate (PMMA), which is one of penetrability materials and a transparent acrylic resin, or polycarbonate (PC). PMMA has been most widely used for the light guide plate 123 because of its excellent characteristics of transparency, weatherability, and colorability.

[0052] To provide a uniform surface light source, the light guide plate 123 may include predetermined patterns at its rear surface. Here, to guide the light incident on the inside of the light guide plate 123, the patterns may be elliptical patterns, polygonal patterns or hologram patterns. The patterns may be formed by a printing method or an injecting method.

[0053] Guide grooves 123c are formed at both sides of the light-incident surface 123a of the light guide plate 123 by removing corners of the light guide plate 123.

[0054] An optical gap A between the light-incident surface 123a of the light guide plate 123 and the LED assembly 129, referring to FIG. 4A, is maintained due to the guide grooves 123c. This will be described in more detail later.

[0055] The reflection sheet 125 is disposed under the rear surface of the light guide plate 123. The reflection sheet 125 reflects light passing through the rear surface of the light guide plate 123 toward the liquid crystal panel 110 to increase the brightness.

[0056] The optical sheets 121 over the light guide plate 123 include a diffuser sheet and at least a light-concentrating sheet. The optical sheets 121 diffuse or concentrate light passing through the light guide plate 123 such that more uniform surface light source is provided to the liquid crystal panel 110.

[0057] The liquid crystal panel 110 and the backlight unit 120 are modularized with the guide panel 130 and the cover bottom 150. The cover bottom 150 has a horizontal plane 151 over which the liquid crystal panel 110 and the backlight unit 120 are disposed, and the cover bottom 150 supports the whole LCD device and minimizes loss of light. The four edges of the horizontal plane 151 of the cover bottom 150 are bent perpendicularly toward the liquid crystal panel 110 and become sides 153.

[0058] The guide panel 130 has a rectangular frame shape. The guide panel 130 is disposed over the cover bottom 150 and surrounds edges of the liquid crystal panel 110 and the backlight unit 120. The guide panel 130 is combined with the cover bottom 150.

[0059] Here, the guide panel 130 includes side walls 131 and horizontal portions 133. The side walls 131 surround side surfaces of the backlight unit 120. The horizontal portions 133 separate positions of the liquid crystal panel 110 and the backlight unit 120 at the inner surface of the side walls 131. The liquid crystal panel 110 is attached and fixed onto the horizontal portions 133 by adhesive pad 118 of FIG. 5A such as a double-sided tape.

[0060] Therefore, the liquid crystal panel 110 and the backlight unit 120 are modularized to form a one-united body.

[0061] The LCD device according to the present invention has light weight and slim thickness and also has a narrow bezel because its display area is formed as wide as possible and its non-display area, that is, a bezel area is formed as narrow as possible.

[0062] At this time, the side walls 131 of the guide panel 130 partly have a double structure. At least one elastic stopper 135 is formed at a part of the side walls 131 having the double structure to prevent movement of the light guide plate 123. For example, two stoppers 135 may be formed at one of the side walls 131.

[0063] Accordingly, in the LCD device according to the present invention, the light guide plate 123 is doubly prevented from moving, and at the same time, the guide panel 130 is prevented from hanging down due to the weight of the liquid crystal panel 110 installed on the horizontal portions 133 of the guide panel 130.

[0064] From this, the optical gap A between the light-incident surface 123a of the light guide plate 123 and the LED assembly 129 for providing a surface light source of high quality to the liquid crystal panel 110, referring to FIG. 4A, can be maintained, and the brightness and the image quality of the LCD device can be improved.

[0065] In addition, since it is not necessary to form additional elements for preventing movement of the light guide plate 123, the light leakage due to the additional elements close to the active area can be prevented.

[0066] Moreover, movement of the light guide plate 123 can be also prevented, and thus it is also prevented that damages of the LEDs 129a of the LED assembly 129 are caused and the image quality is lowered because the optical properties of the LCD device are changed.

[0067] Here, the guide panel 130 may be referred to as a support main, a main support or a mold frame, and the cover bottom 150 may be referred to as a bottom cover or a lower cover.

[0068] The LCD device according to the embodiment of the present invention does not include a top cover 40 of FIG. 1. Therefore, the LCD device has light weight, slim thickness and narrow bezel, and manufacturing processes are simplified.

[0069] Furthermore, manufacturing costs are decreased due to omission of the top cover 40 of FIG. 1.

[0070] The above-mentioned LCD device according to the embodiment of the present invention has a structure of doubly preventing movement of the light guide plate 123 by forming the side walls 131 of the guide panel 130 having a double structure. Thus, the optical gap A of FIG. 4A between the light guide plate 123 and the LED assembly 129 can be uniformly maintained.

[0071] Accordingly, the brightness and the image quality of the LCD device are prevented from being lowered due to the movement of the light guide plate 123, and the LEDs 129a of the LED assembly 129 are prevented from being damaged. Moreover, the light leakage due to additional elements for preventing movement of the light guide plate 123 can be prevented.

[0072] FIG. 3A is a perspective view of schematically illustrating a guide panel of an embodiment of the present invention, and FIGS. 3B to 3D are views of enlarging a part of the guide panel of FIG. 3A.

[0073] In FIGS. 3A to 3D, the guide panel 130, which surround edges of the backlight unit 120 of FIG. 2, is formed of a mold substance of a synthetic resin such as polycarbonate. The guide panel 130 includes side walls 131 and horizontal portions 133. The side walls 131 surround the edges of the backlight unit 120 of FIG. 2. The horizontal portions 133

extend from the inner surface of the side walls 131, and the liquid crystal panel 110 of FIG. 2 is disposed on the horizontal portions 133.

[0074] At this time, the side walls 131 of the guide panel 130 have a double structure. An elastic stopper 135 is formed at an edge of one side wall 131 covering an opposite light-incident surface 123b of the light guide plate 123 of FIG. 2, which is opposite to the light-incident surface 123a.

[0075] More particularly, the guide panel 130 has a rectangular frame shape and is formed by an injection molding method using a synthetic resin. The guide panel 130 includes a first part 130a, a second part 130b, a third part 130c and a fourth part 130d. The LED assembly 129 of FIG. 2 is arranged on the first part 130a. The second part 130b is disposed opposite to the first part 130a. The third and fourth parts 130c and 130d connect the first and second parts 130a and 130b. Each of the first, second, third and fourth parts 130a, 130b, 130c and 130d includes the side walls 131 surrounding the edges of the backlight unit 120 of FIG. 2 and the horizontal portions 133 being perpendicular to the side walls 131 and separating the backlight unit 120 of FIG. 2 and the liquid crystal panel 110 of FIG. 2.

[0076] At this time, the liquid crystal panel 110 of FIG. 2 is disposed on and supported by the horizontal portions 133.

[0077] Here, each of the side walls 131 may include a first vertical portion 131a and a second vertical portion 131b. The first vertical portion 131a is vertically bent from an end of the horizontal portion 133, and the second vertical portion 131b is formed under the horizontal portion 133 and is spaced apart from and faces the first vertical portion 131a.

[0078] Therefore, a part of the guide panel 130 may have a U-like shape in a cross-section due to the first and second vertical portions 131a and 131b and the horizontal portions 133.

[0079] At this time, the first and second vertical portions 131a and 131b are spaced apart from each other, and the sides 153 of the cover bottom 150 of FIG. 2 are inserted into spaces between the first and second vertical portions 131a and 131b. The liquid crystal panel 110 of FIG. 2 is disposed on the horizontal portions 133. Four edges of the rear surface of the liquid crystal panel 110 of FIG. 2 are disposed on and supported by the horizontal portions 133, thereby being fixed.

[0080] Here, since the part of the side walls 131 of the guide panel includes a double structure of the first and second vertical portions 131a and 131b, the strength of the guide panel 130 is increased. Thus, when the liquid crystal panel 110 is disposed on the horizontal portions 133 of the guide panel 130, the guide panel 130 is prevented from hanging down due to the weight of the liquid crystal panel 110.

[0081] At this time, at least two elastic stoppers 135 are formed at the side wall 131 of the second part 130b of the guide panel 130, which is opposite to the first part 130a corresponding to the LED assembly 129 of FIG. 2, along a length direction of the second part 130b.

[0082] Namely, the side wall 131 of the second part 130b has an area where the second vertical portion 131b is not formed, and the elastic stopper 135 is formed in the area as shown in FIG. 3B and FIG. 3C.

[0083] Here, the elastic stopper 135 is formed under the horizontal portion 133 and extends from the horizontal portion 133 to be inclined by a predetermined angle from a normal line perpendicular to the horizontal portion 133 toward an opposite side to the first vertical portion 131a. A hole 135a is formed at the elastic stopper 135 corresponding

to a connection point with the horizontal portion 133. A step portion 135b is formed under the hole 135a and protrudes toward an opposite direction to the first vertical portion 131a. The step portion 135b faces the opposite light-incident surface 123b.

[0084] The elastic stopper 135 is formed at the second part 130b of the guide panel 130 and faces the opposite light-incident surface 123b of the light guide plate 123. Since the elastic stopper 135 formed at the second part 130b of the guide panel 130 is inclined with a predetermined angle from a normal line to the horizontal portion 133 to the opposite direction to the first vertical portion 131a, the elastic stopper 135 contacts the opposite light-incident surface 123b of the light guide plate 123 as shown in FIG. 3D and applies certain force to the light guide plate 123.

[0085] Accordingly, the optical gap A between the LED assembly 129 of FIG. 2 and the light-incident surface 123a of FIG. 2 of the light guide plate 123, referring to FIG. 4A, is uniformly maintained by the elastic stopper 135.

[0086] In addition, the elastic stopper 135 has elastic restoring force like a spring along an X-axis direction defined in FIG. 3B.

[0087] Therefore, even though vibrations and impacts from the outside are applied to the modularized LCD device and the light guide plate 123 moves, the optical gap A of FIG. 4A between the LED assembly 129 of FIG. 2 and the light-incident surface 123a of FIG. 2 of the light guide plate 123 is uniformly maintained because the light guide plate 123 goes back to its original position at once due to the elastic restoring force of the elastic stopper 135.

[0088] Moreover, the light guide plate 123 may be disposed under high temperatures for a long time owing to driving of the backlight unit 120 of FIG. 2 and driving of the liquid crystal panel 110 of FIG. 2, and the light guide plate 123 may be expanded. At this time, however, since the elastic stopper 135 applies certain force to the light guide plate 123, and an amount of expansion of the light guide plate 123 is decreased.

[0089] Furthermore, even though the light guide plate 123 is expanded, an amount of expansion of the light guide plate 123 is enabled to be absorbed by the elastic restoring force of the elastic stopper 135, and the movement of the light guide plate 123 is prevented.

[0090] Additionally, since the elastic stopper 135 has movements in a certain range due to its elastic restoring force, vibrations and impacts applied to the light guide plate 123 are absorbed by the movements, and the light guide plate 123 is prevented from being destroyed.

[0091] Moreover, although the light guide plate 123 is contracted due to its material property, certain force can be applied to the light guide plate 123 through the elastic stopper 135, and thus the optical gap A of FIG. 4A between the LED assembly 129 of FIG. 2 and the light-incident surface 123a of the light guide plate 123 can be uniformly maintained.

[0092] Furthermore, by applying certain force to the light guide plate 123 through the elastic stopper 135 formed at the guide panel 130, the light guide plate 123 is prevented from being moved. Thus, it is not necessary to form additional elements for preventing movement of the light guide plate 123, and occurrence of the light leakage due to the additional elements can be prevented.

[0093] From this, improvement in the brightness and the image quality increases the qualities of the LCD device.

[0094] In the meantime, a part of the side walls 131 of the guide panel 130 of the present invention has a double struc-

ture of first and second vertical portions **131a** and **131b**. When the light guide plate **123** is expanded more than the elastic restoring force of the elastic stopper **135**, the force applied to the elastic stopper **135** can be dispersed by the second vertical portion **131b**. Thus, the light guide plate **123** is more stably prevented from being moved and damaged, and the optical gap A of FIG. 4A between the LED assembly **129** of FIG. 2 and the light-incident surface **123a** of FIG. 2 of the light guide plate **123** is uniformly maintained.

[0095] At this time, the elastic stopper **135** has a hole **135a** around a connection point with the horizontal portion **133**. Therefore, movement of the elastic stopper **135** is improved, and the elastic restoring force of the elastic stopper **135** is increased.

[0096] Here, if the hole **135a** is not formed at the elastic stopper **135**, when impacts from the outside are applied to the elastic stopper **135**, the impacts are not applied to the only elastic stopper **135** but are applied to the whole guide panel **130** because the elastic restoring force of the elastic stopper is low.

[0097] Accordingly, this causes movement of the guide panel **130** itself. As a result, the light guide plate **123** also moves due to the movement of the guide panel **130**. Therefore, the LEDs **129a** of FIG. 2 of the LED assembly **129** of FIG. 2 may be damaged, or optical properties of the LCD device may be changed, thereby causing problems of lowering image qualities. It is therefore very effective to configure the hole **135a** of the present embodiment for obviating such problems.

[0098] Additionally, in the elastic stopper **135** of the present invention, by forming the step portion **135b** under the hole **135a**, more force can be applied to the light guide plate **123**.

[0099] Thus, even though the elastic restoring force of the elastic stopper **135** is low, the force applied to the light guide plate **123** increases due to the step portion **135b** formed at a side of the elastic stopper **135**. The movement of the light guide plate **123** can be stably prevented, and the optical gap A of FIG. 4A between the LED assembly **129** of FIG. 2 and the light-incident surface **123a** of FIG. 2 of the light guide plate **123** can be uniformly maintained.

[0100] FIG. 4A is a plan view of a guide panel and a light guide plate according to an embodiment of the present invention, and FIG. 4B is a cross-sectional view of a modularized LCD device of FIG. 2 taken along the line IV-IV' of FIG. 4A.

[0101] In FIG. 4A and FIG. 4B, the guide panel **130** has a rectangular frame shape and includes side walls **131** surrounding the side surfaces of the backlight unit **120** of FIG. 2 and horizontal portions **133** vertically protruding from the side walls **131**.

[0102] At this time, the side walls **131** partly have a double structure of first and second vertical portions **131a** and **131b**. An elastic stopper **135** is formed at a side covering the opposite light-incident surface **123b** of the light guide plate **123** of the backlight unit **120** of FIG. 2.

[0103] The light guide plate **123** is disposed inside the guide panel **130**, and the LED assembly **129** is arranged along a side of the guide panel **130** corresponding to the light-incident surface **123a** of the light guide plate **123**.

[0104] At this time, guide grooves **123c** are formed at both sides of the light-incident surface **123a** of the light guide plate **123** by removing corners of the light guide plate **123**. Stop-

pers **137** are formed to correspond to the guide grooves **123c** and disposed at both sides perpendicular to a side of the guide panel **130**.

[0105] Therefore, the light guide plate **123** is prevented from being moved along -X-axis direction defined in the figure due to the elastic stopper **135**, and the light guide plate **123** is prevented from being moved along +X-axis direction due to the stopper **137**. Accordingly, the optical gap A between the light guide plate **123** and the LED assembly **129** is uniformly maintained.

[0106] In addition, even though vibrations and impacts from the outside are applied to the modularized LCD device and the light guide plate **123** moves, the optical gap A between the LED assembly **129** and the light-incident surface **123a** of the light guide plate **123** is uniformly maintained because the light guide plate **123** goes back to its original position at once due to the elastic restoring force of the elastic stopper **135**.

[0107] Moreover, since the elastic stopper **135** applies certain force to the light guide plate **123**, and an amount of expansion of the light guide plate **123** is decreased. Although the light guide plate **123** is expanded, an amount of expansion of the light guide plate **123** is enabled to be absorbed by the elastic restoring force of the elastic stopper **135**, and the movement of the light guide plate **123** is prevented.

[0108] Furthermore, vibrations and impacts are absorbed by the elastic stopper **135**, and the light guide plate **123** is prevented from being destroyed. Although the light guide plate **123** is contracted due to its material property, certain force can be applied to the light guide plate **123**, and thus the optical gap A between the LED assembly **129** and the light-incident surface **123a** of the light guide plate **123** can be uniformly maintained.

[0109] FIGS. 5A and 5B are cross-sectional views of a modularized LCD device of FIG. 2 taken along the line V-V' of FIG. 4A.

[0110] In FIGS. 5A and 5B, the backlight unit **120** includes the reflection sheet **125**, the light guide plate **123**, the LED assembly **129** comprised of the LEDs **129a** and the PCB **129b** on which the LEDs **129a** are mounted, and the optical sheets **121** sequentially located over the light guide plate **123**.

[0111] The liquid crystal panel **110** is disposed over the backlight unit **120** and includes the first and second substrates **112** and **114** and the liquid crystal layer (not shown) between the first and second substrates **112** and **114**. The polarizers **119a** and **119b** are attached at outer surfaces of the first and second substrates **112** and **114** and selectively transmit specific light.

[0112] Here, edges of the backlight unit **120** are surrounded by the guide panel **130**, and the cover bottom **150** is disposed at the rear surface of the backlight unit **120** and is combined with the guide panel **130**.

[0113] The guide panel **130** includes the side walls **131** and the horizontal portions **133**. The side walls **131** surround the side surfaces of the backlight unit **120**. The horizontal portions **133** protrude inwards from the side walls **131** and cover an upper portion of the LED assembly **129** and upper edges of the light guide plate **123**.

[0114] At this time, the side walls **131** of the guide panel **130** have a double structure, and each of the side walls **131** includes the first vertical portion **131a** and the second vertical portion **131b**. The first vertical portion **131a** is vertically bent from the end of the horizontal portion **133**. The second ver-

tical portion **131b** is formed under the horizontal portion **133**, and is spaced apart from and faces the first vertical portion **131a**.

[0115] Therefore, a part of the guide panel **130** may have a U-like shape in a cross-section due to the first and second vertical portions **131a** and **131b** and the horizontal portions **133**. The sides **153** of the cover bottom **150** are inserted into the spaces between the first and second vertical portions **131a** and **131b**.

[0116] Four edges of the rear surface of the liquid crystal panel **110** are disposed on and supported by the horizontal portions **133**. The adhesive pad **118** is used to fix the liquid crystal panel **110**.

[0117] The adhesive pad **118**, which is formed of an adhesive material such as a double-sided tape, fixes the liquid crystal panel **110** on the horizontal portions **133**.

[0118] At this time, the elastic stopper **135** is formed at the guide panel **130** facing the opposite light-incident surface **123b**, which is opposite to the light-incident surface **123a** of the light guide plate **123**. The elastic stopper **135** is formed under the horizontal portion **133** and extends from the horizontal portion **133** to be inclined by a predetermined angle from a normal line perpendicular to the horizontal portion **133** toward an opposite side to the first vertical portion **131a**.

[0119] In addition, the hole **135a** is formed at the elastic stopper **135** around a connection point with the horizontal portion **133**. The step portion **135b** is formed under the hole **135a** and protrudes toward an opposite direction to the first vertical portion **131a**.

[0120] The elastic stopper **135** contacts the opposite light-incident surface **123b** of the light guide plate **123**, and as shown in FIG. 5A, the elastic stopper **135** applies certain force to the light guide plate **123** toward the LED assembly **129**.

[0121] Therefore, in the LCD device of the present invention, the optical gap A between the LED assembly **129** and the light guide plate **123** for providing the surface light source of a high quality to the liquid crystal panel **110**, as an important role of the backlight unit **120**, is uniformly maintained by the elastic stopper **135**.

[0122] At this time, when impacts from the outside are applied to the modularized LCD device, the elastic stopper **135** moves within a predetermined range, as shown in FIG. 5B, due to the elastic restoring force of the elastic stopper **135**, and the vibrations and impacts are absorbed by the movement of the elastic stopper **135**. Accordingly, the light guide plate **123** is prevented from being damaged.

[0123] In addition, even though the light guide plate **123** moves, the light guide plate **123** goes back to its original position at once due to the elastic restoring force of the elastic stopper **135**, and the optical gap A between the LED assembly **129** and the light incident surface **123a** of the light guide plate **123** is uniformly maintained.

[0124] Moreover, although the light guide plate **123** is contracted due to its material property, the optical gap A between LED assembly **129** and the light-incident surface **123a** of the light guide plate **123** is uniformly maintained by applying certain force to the light guide plate **123** through the elastic stopper **135**.

[0125] Furthermore, when the light guide plate **123** is expanded, the amount of expansion of the light guide plate **123** is absorbed by the elastic restoring force of the elastic stopper **135**, and thus movement of the guide panel **130** is prevented.

[0126] For example, when the coefficient of linear expansion of the light guide plate **123** is $6.5E-5/^{\circ}C.$, the light guide plate **123** may be expanded by about 0.7 mm under temperature of 60 degrees of Celsius. At this time, to form a narrow bezel, when the total gap between the light guide plate **123** and the guide panel **130** is 0.2 mm, there may be an overlap of 0.5 mm between the light guide plate **123** and the guide panel **130**.

[0127] The overlap causes movement of the guide panel **130**.

[0128] To prevent the movement of the guide panel **130**, the total gap between the light guide plate **123** and the guide panel **130** may be 0.7 mm by considering the overlap resulting from the expansion of the light guide plate **123**, and in this case, it is difficult to form a narrow bezel.

[0129] However, in the present invention, even though the light guide plate **123** is expanded, the expansion of the light guide plate **123** is absorbed by the elastic restoring force of the elastic stopper **135**, and the movement of the guide panel **130** is prevented.

[0130] Accordingly, it is not needed to determine the total gap between the light guide plate **123** and the guide panel **130** considering the overlap due to the expansion of the light guide plate **123** such that the guide panel **130** is prevented from moving. Thus, the narrow bezel can be formed.

[0131] Particularly, in the guide panel **130** according to the embodiment of the present invention, the hole **135a** is formed at the elastic stopper **135**, and the movement of the elastic stopper **135** is improved. Therefore, the elastic restoring force of the elastic stopper is further increased.

[0132] Here, if the hole **135a** is not formed at the elastic stopper **135**, when impacts from the outside are applied to the elastic stopper **135**, the impacts are not applied to the only elastic stopper **135** but are applied to the whole guide panel **130** because the elastic restoring force of the elastic stopper is low.

[0133] FIG. 6A and FIG. 6B are simulation results of measuring an amount of deformation of a guide panel depending on an elastic stopper with or without a hole according to the embodiment of the present invention, and FIG. 6C is a simulation result of measuring tensile strength of an elastic stopper.

[0134] As shown in FIG. 6A, when the hole is not formed at the elastic stopper **135**, the amount of deformation of the guide panel **130** is 0.02 mm.

[0135] On the contrary, as shown in FIG. 6B, the embodiment of the present invention comprises the elastic stopper **135** having the hole **135a**, the possible movement due to its elastic restoring force is increased to 0.7 to 0.8 mm.

[0136] Therefore, even though the light guide plate **123** having the coefficient of linear expansion of $6.5E-5/^{\circ}C.$ is expanded by about 0.7 mm under temperature of 60 degrees of Celsius, all the expansion of the light guide plate **123** of FIG. 5B is absorbed by the elastic stopper **135**, and the guide panel **130** is prevented from being moved by the expansion of the light guide plate **123** of FIG. 5B. Accordingly, the total gap between the light guide plate **123** and the guide panel **130** can be 0.2 mm, and thus the narrow bezel can be formed.

[0137] Moreover, FIG. 6C is a simulation result of measuring tensile strength of an elastic stopper when the light guide plate slowly pushes the guide panel, and as shown in FIG. 6C, even though the elastic stopper **135** according to the embodiment of the present invention has the possible movement of 0.7 to 0.8 mm due to its elastic restoring force, the maximum

tensile strength applied to the elastic stopper **135** due to the movement of the light guide plate **123** is 26.6 MPa, which is lower than 65 MPa, the tensile strength of the guide panel **130**. Thus, the damage of the elastic stopper **135** is prevented.

[0138] FIGS. 7A to 7D are simulation results of measuring light leakage when an LCD device according to the present invention is driven under different temperatures.

[0139] Here, FIGS. 7A and 7B are simulation results of measuring light leakage when the LCD device according to the embodiment of the present invention is driven under high temperature of 60 degrees of Celsius, and FIGS. 7C and 7D are simulation results of measuring light leakage when the LCD device according to the embodiment of the present invention is driven under low temperature of 0 degree of Celsius.

[0140] Referring to FIGS. 7A to 7D, the LCD device of the present invention has narrow bezels and does not include additional elements at the light guide plate **123** of FIG. 5B. Thus, even though the LCD device is driven under high or low temperature, there is no light leakage.

[0141] As stated above, in the LCD device of the present invention, the part of the side walls **131** of the guide panel **130** of FIG. 5B includes a double structure, and the strength of the guide panel **130** is increased. The elastic stopper **135** is formed at the side walls **131** of the guide panel **130** of FIG. 5B, and the optical gap A of FIG. 5B between the light guide plate **123** of FIG. 5B and the LED assembly **129** of FIG. 5B is uniformly maintained.

[0142] From this, the light guide plate **123** of FIG. 5B is prevented from being moved due to the movement of the guide panel **130**, and the brightness and image qualities of the LCD device are improved.

[0143] In addition, since it is not necessary to form the additional elements at the light guide plate **123** of FIG. 5B, the light leakage due to the additional elements is prevented.

[0144] Moreover, the LEDs **129a** of the LED assembly **129** of FIG. 5B are prevented from being damaged, and the image qualities are prevented from being lowered due to changes of the optical properties of the LCD device.

[0145] It will be apparent to those skilled in the art that various modifications and variation can be made in the present invention without departing from the spirit or scope of the invention. Thus, it is intended that the present invention cover the modifications and variations of this invention provided they come within the scope of the appended claims and their equivalents.

What is claimed is:

1. A liquid crystal display device, comprising:
 - a liquid crystal panel;
 - a backlight unit disposed at a rear side of the liquid crystal panel;

a cover bottom in which the backlight unit is disposed; and a guide panel;

wherein the backlight unit further comprises:

- an LED assembly; and

- a light guide plate having a first surface and a second surface opposite to the first surface, wherein the first surface faces the LED assembly;

wherein the cover bottom further includes:

- a horizontal plane; and

- a side perpendicular to the horizontal plane,

- wherein the backlight unit is disposed over the horizontal plane,

wherein the guide panel further includes:

- a side wall having a first vertical portion; and

- a horizontal portion being vertically bent from the first vertical portion,

- wherein the first vertical portion is configured to surround an outer surface of the side of the cover bottom,

- wherein the horizontal portion is configured to support the liquid crystal panel,

wherein at least one elastic stopper is formed at the side wall of the guide panel and contacts the second surface of the light guide plate.

2. The device according to claim 1, wherein the side wall further includes a second vertical portion that is spaced apart from the first vertical portion and surrounds an edge of the backlight unit.

3. The device according to claim 1, wherein the elastic stopper is formed under the horizontal portion and extends from the horizontal portion to be inclined by a predetermined angle from a normal line perpendicularly to the horizontal portion toward an opposite side to the first vertical portion.

4. The device according to claim 1, wherein a hole is formed at the elastic stopper corresponding to a connection point with the horizontal portion.

5. The device according to claim 1, wherein the elastic stopper includes a step portion protruding toward the second surface of the light guide plate.

6. The device according to claim 1, wherein at least two elastic stoppers are formed along a length direction of the side wall of the guide panel.

7. The device according to claim 1, wherein stoppers are formed at side walls disposed at both sides of and being perpendicular to the side wall of the guide panel including the elastic stopper to maintain an optical gap between the first surface of the light guide plate and the LED assembly.

8. The device according to claim 1, wherein guide grooves are formed at both ends of the first surface of the light guide plate, and the stoppers are inserted into the guide grooves.

* * * * *

专利名称(译)	液晶显示装置		
公开(公告)号	US20140176869A1	公开(公告)日	2014-06-26
申请号	US14/075312	申请日	2013-11-08
[标]申请(专利权)人(译)	乐金显示有限公司		
申请(专利权)人(译)	LG DISPLAY CO. , LTD.		
当前申请(专利权)人(译)	LG DISPLAY CO. , LTD.		
[标]发明人	LEE JUN JAE AN SU YOUNG PARK CHIN IL		
发明人	LEE, JUN-JAE AN, SU-YOUNG PARK, CHIN-IL		
IPC分类号	G02F1/1335		
CPC分类号	G02F1/133615 G02B6/0088 G02B6/009 G02B6/0093 G02F2001/133317 G02F2001/133322 G02F2201/503		
优先权	1020120151797 2012-12-24 KR 1020130114455 2013-09-26 KR		
其他公开文献	US9316864		
外部链接	Espacenet USPTO		

摘要(译)

LCD装置包括液晶面板;背光单元,设置在液晶面板的后侧,包括LED组件和导光板,导光板具有面向LED组件的第一表面和与第一表面相对的第二表面;盖底部,包括设置有背光单元的水平面和垂直于水平面的一侧;包括侧壁和水平部分的引导板,其中侧壁具有围绕盖底侧面的外表面的第一垂直部分,并且水平部分从第一垂直部分垂直弯曲并支撑液晶如图所示,其中至少一个弹性挡块形成在侧壁上并与第二表面接触。

