



(19) **United States**

(12) **Patent Application Publication**
Song

(10) **Pub. No.: US 2012/0086665 A1**

(43) **Pub. Date: Apr. 12, 2012**

(54) **LIQUID CRYSTAL DISPLAY DEVICE**

(52) **U.S. Cl. 345/174; 345/173; 345/104**

(76) **Inventor: InHyuk Song, Gyeonggi-do (KR)**

(21) **Appl. No.: 13/244,988**

(57) **ABSTRACT**

(22) **Filed: Sep. 26, 2011**

(30) **Foreign Application Priority Data**

Oct. 8, 2010 (KR) 10-2010-0098256

Publication Classification

(51) **Int. Cl.**
G09G 3/36 (2006.01)
G06F 3/045 (2006.01)
G06F 3/041 (2006.01)

A liquid crystal display device is disclosed, which comprises first and second substrates; gate and data lines arranged to cross each other on the first substrate to define a pixel region; a pixel electrode formed in the pixel region; a common electrode forming an electric field together with the pixel electrode and sensing a touch of a user; a light shielding layer formed on the second substrate to shield light leakage to a region other than the pixel region; column spacers formed on the light shielding layer to maintain a cell gap; and a sensing line formed on the column spacers and electrically connected with the common electrode.

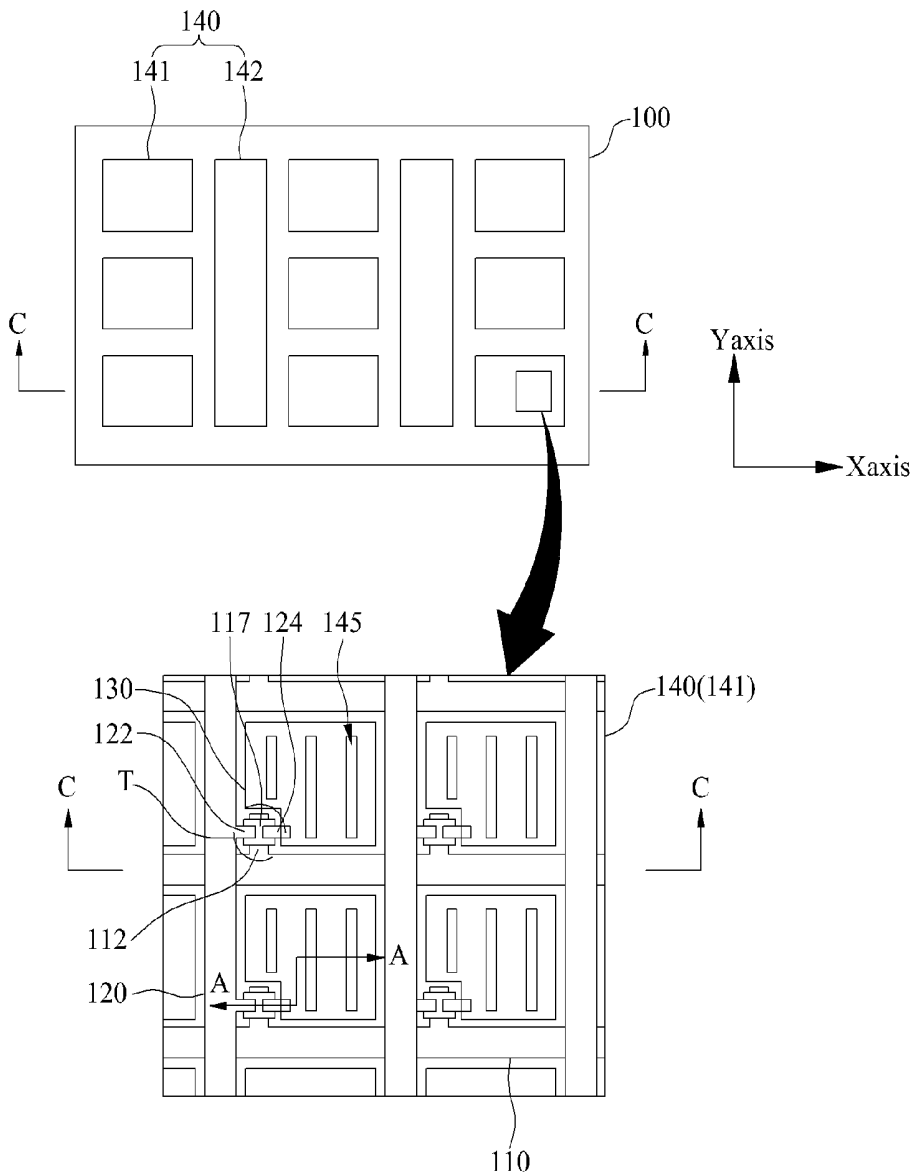

FIG.1

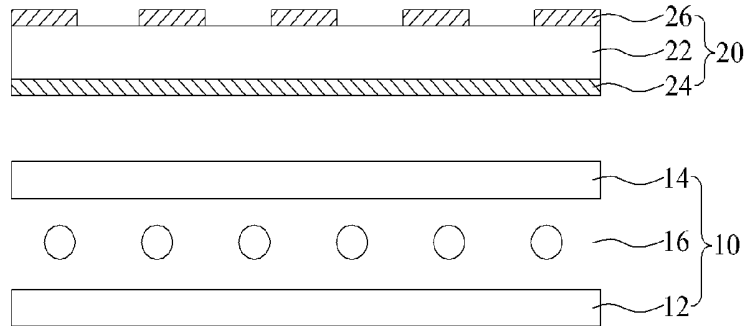

FIG.2A

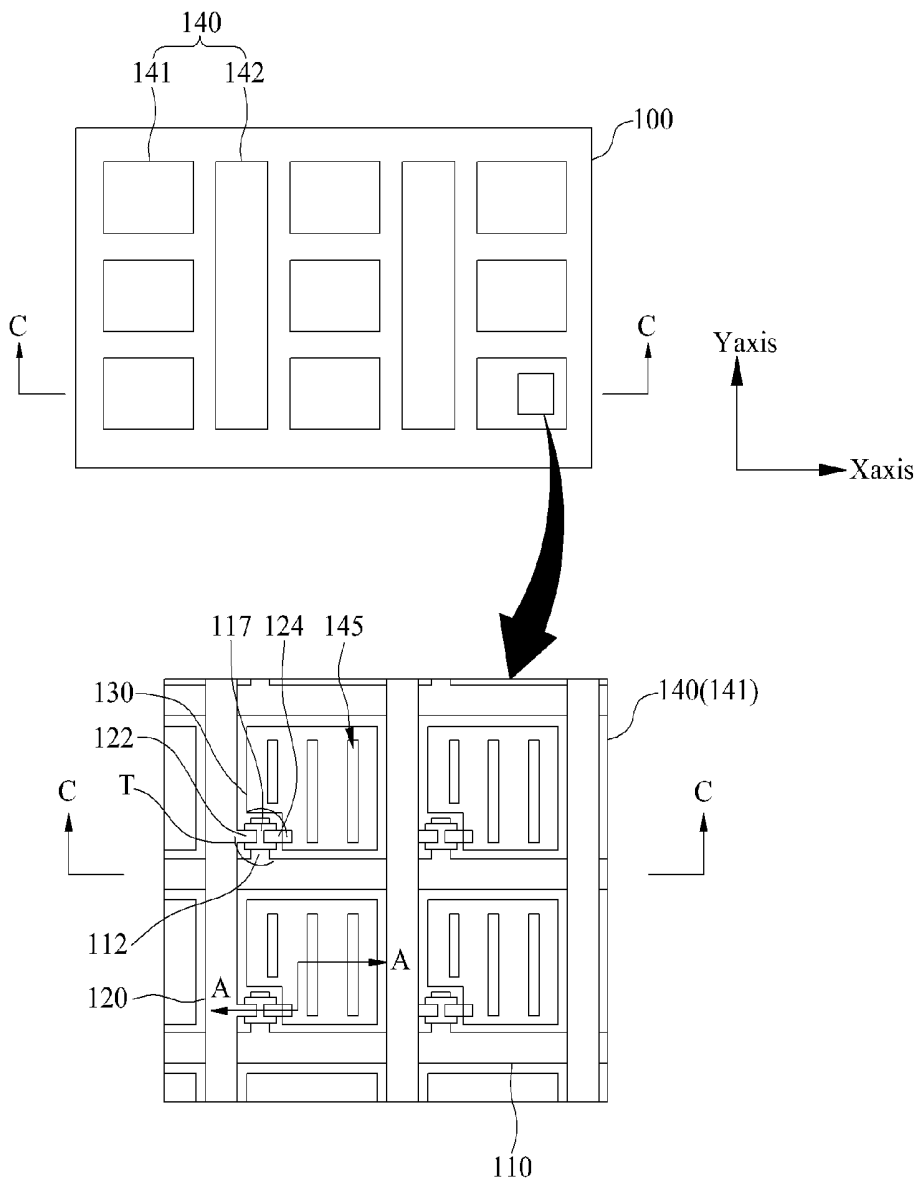

FIG. 2B

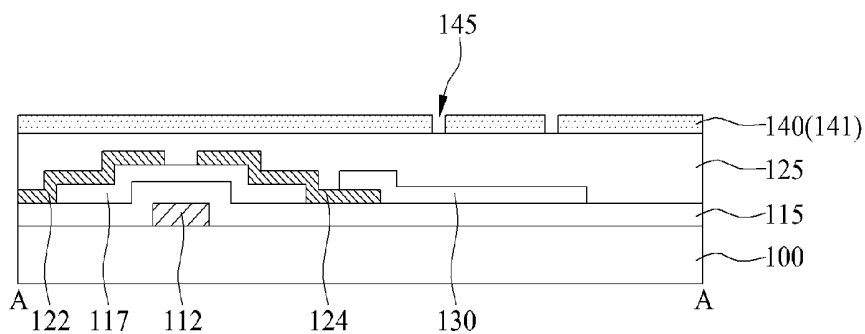

FIG. 2C

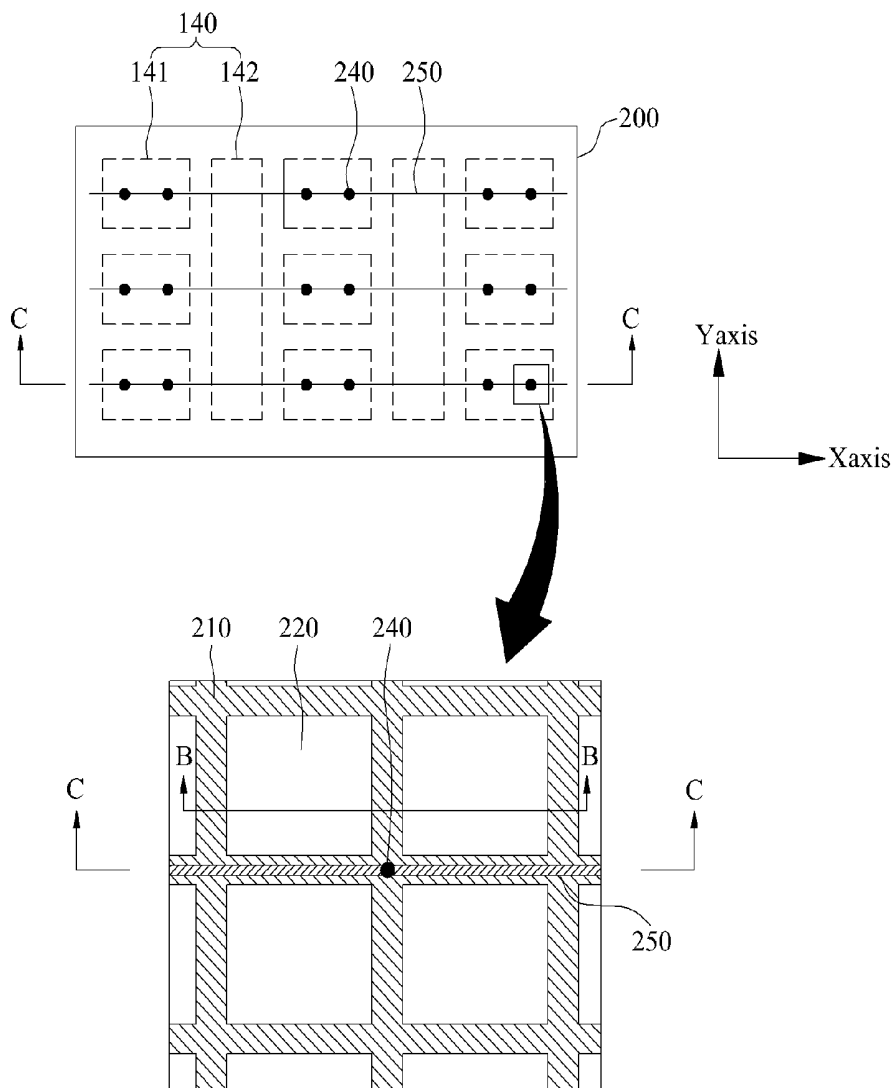

FIG.2D

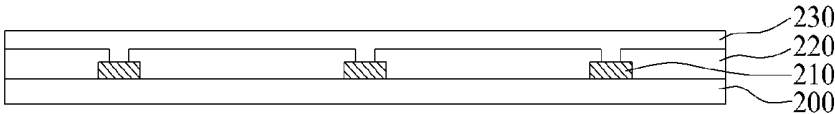

FIG.2E

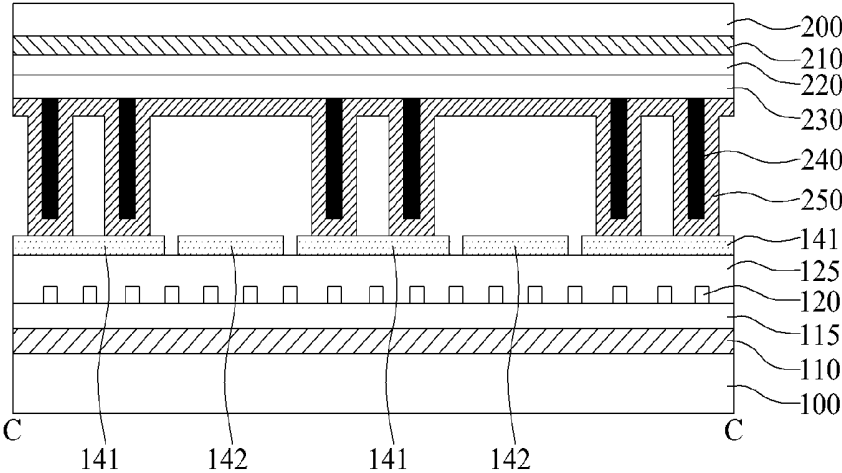

FIG. 3A

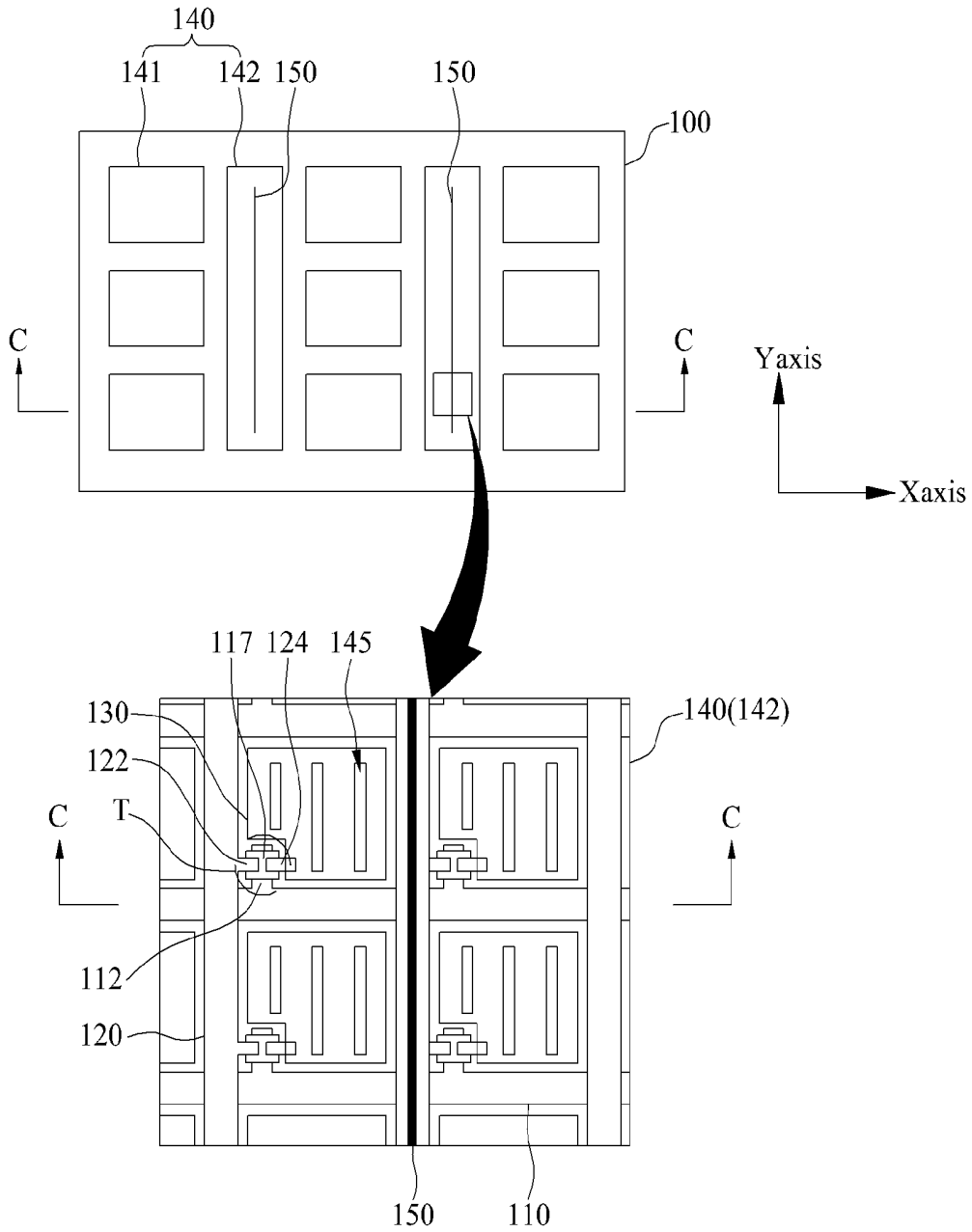

FIG.3B

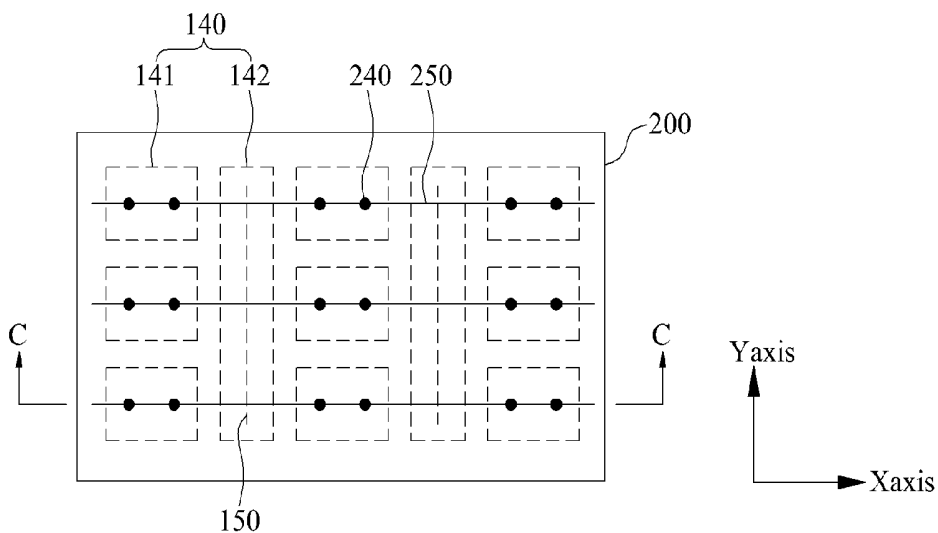

FIG.3C

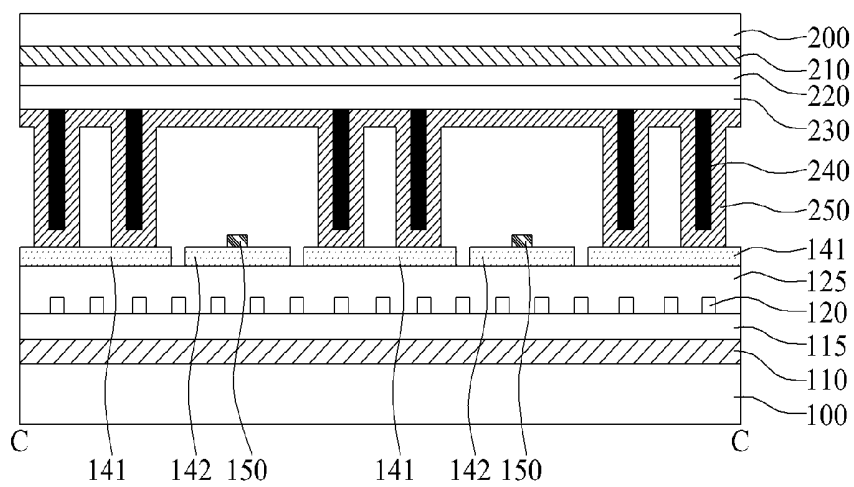

FIG. 4A

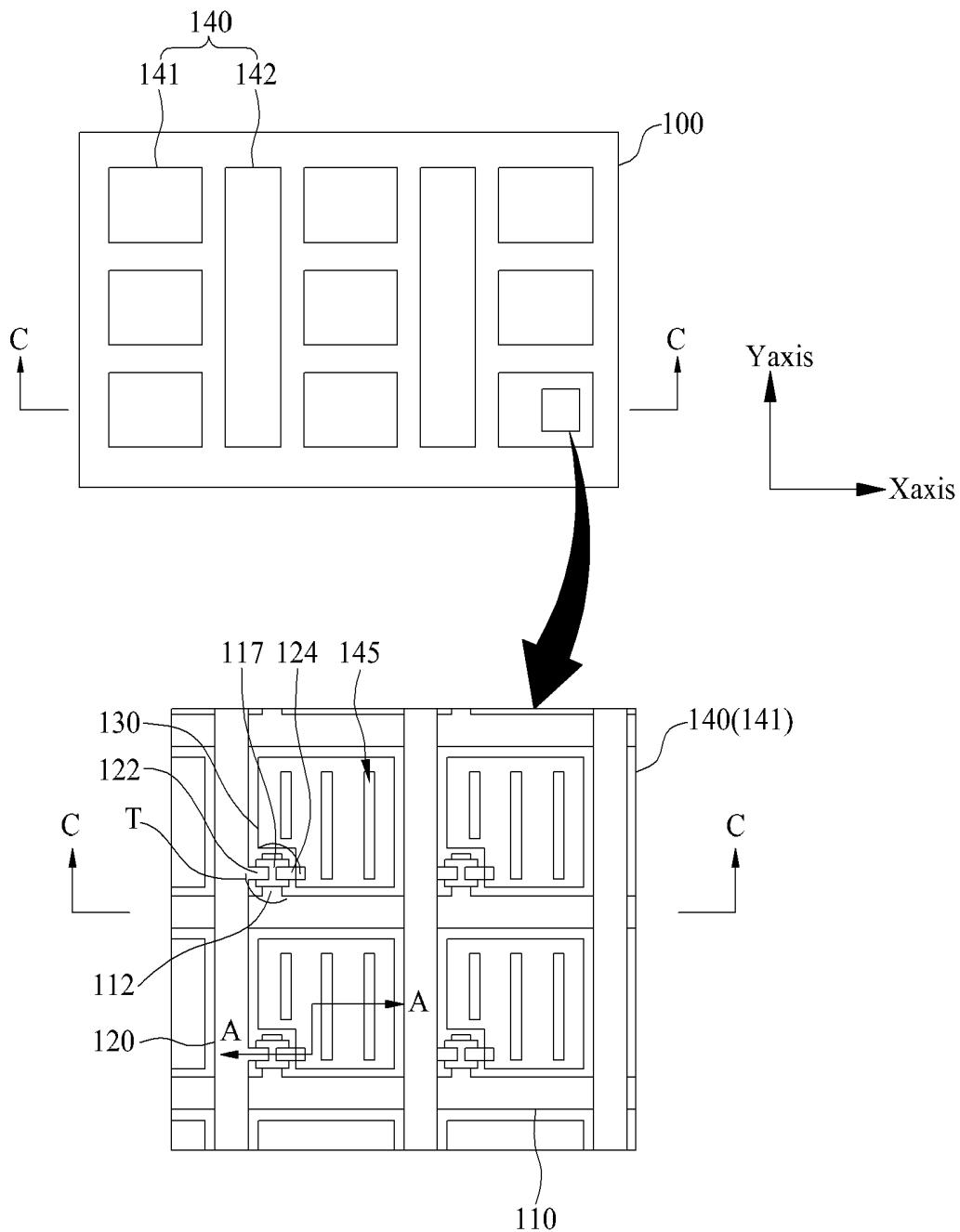

FIG. 4B

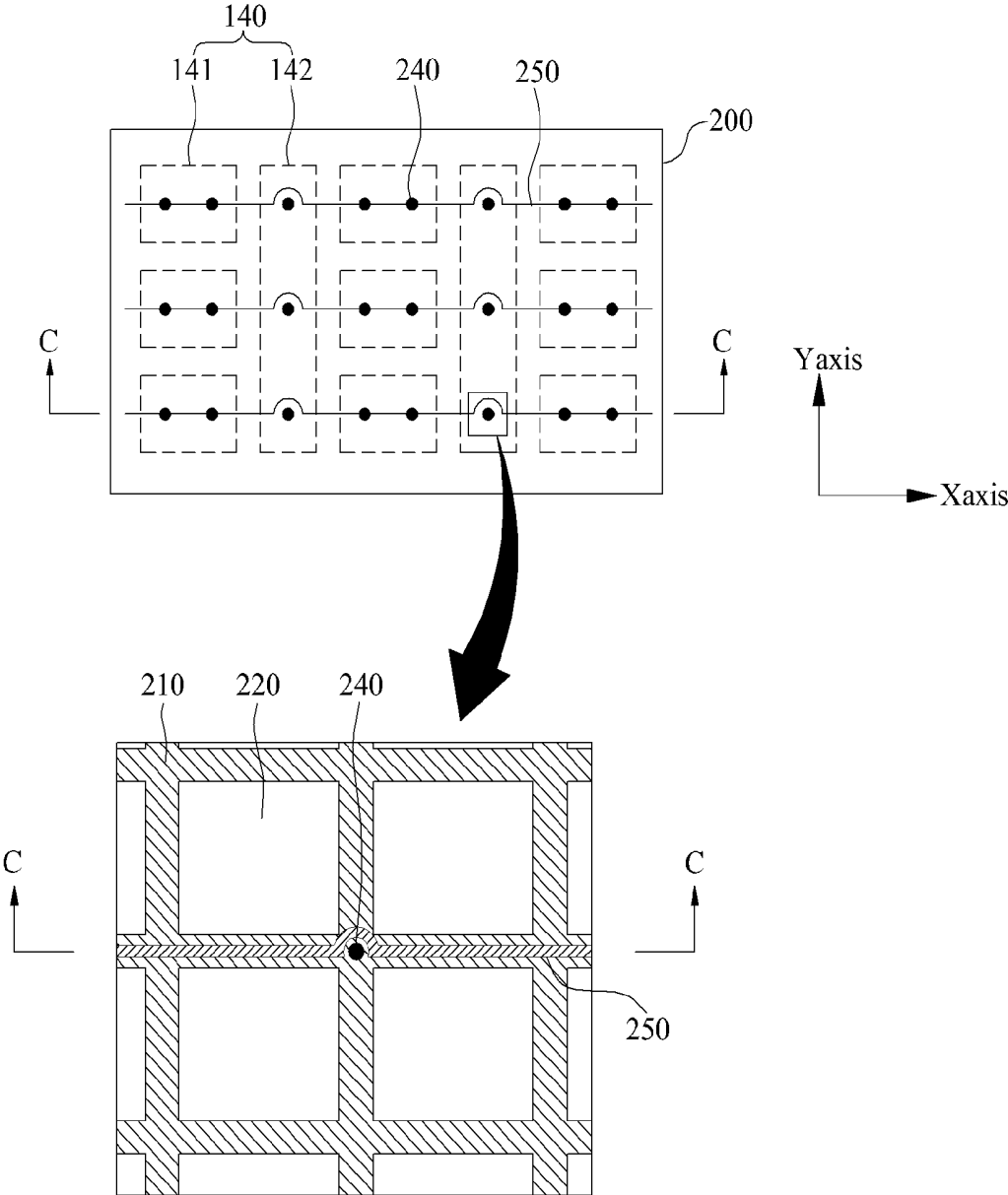

FIG.4C

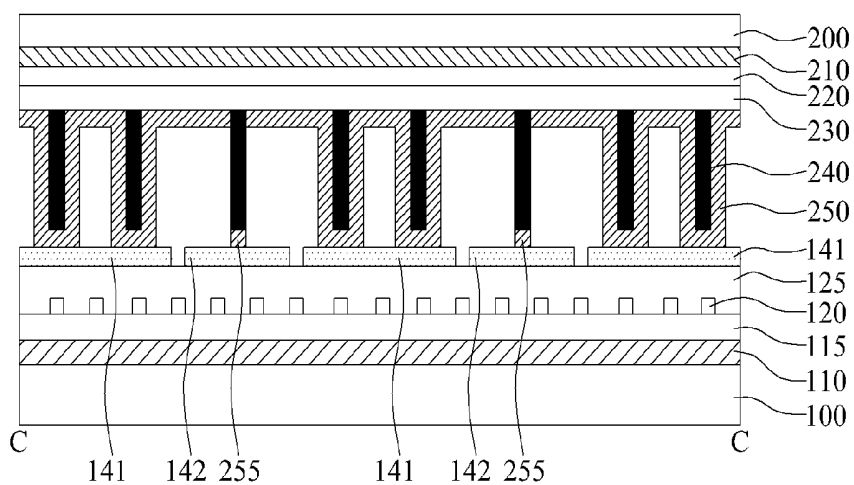

FIG.5A

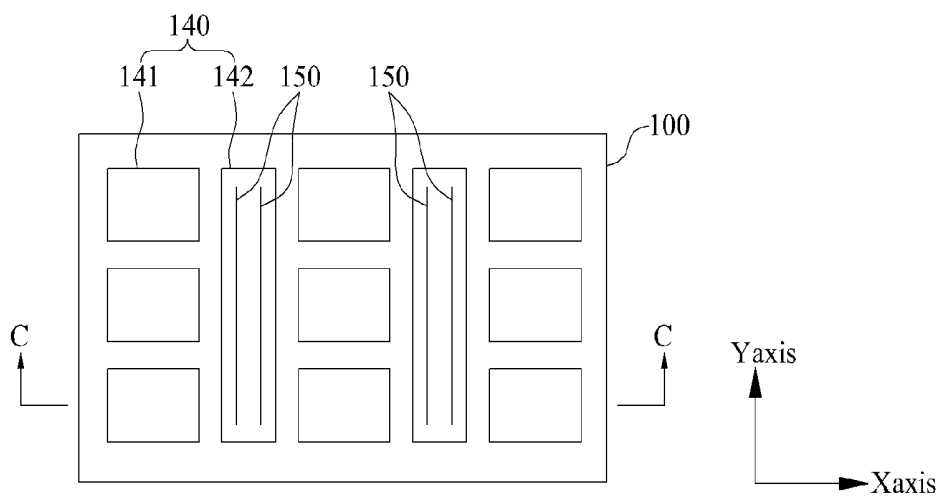

FIG.5B

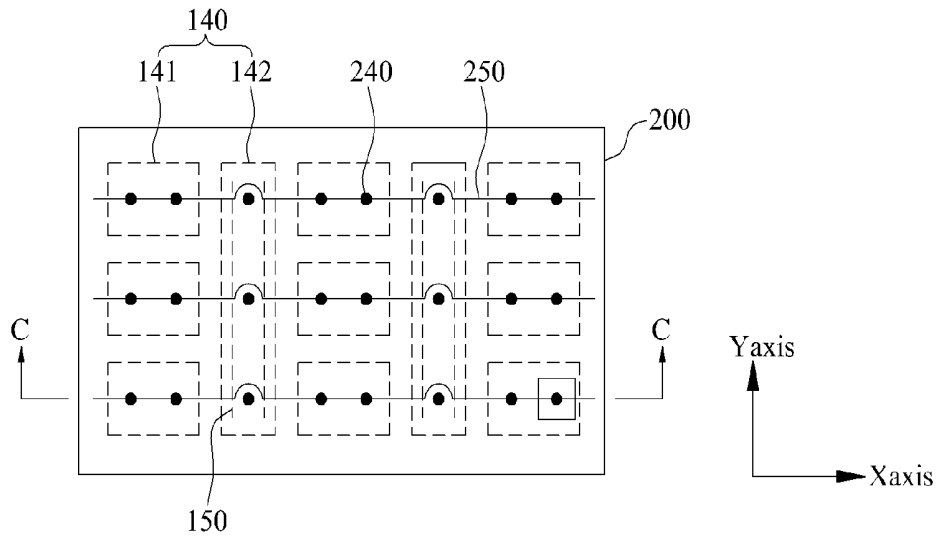
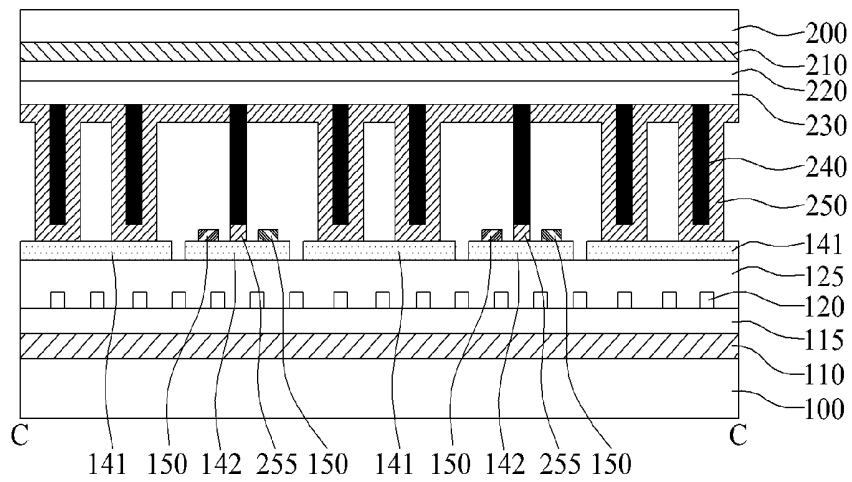

FIG.5C



LIQUID CRYSTAL DISPLAY DEVICE

CROSS REFERENCE TO RELATED APPLICATIONS

[0001] This application claims the benefit of the Korean Patent Application No. 10-2010-0098256 filed on Oct. 8, 2010, which is hereby incorporated by reference for all purposes as if fully set forth herein.

BACKGROUND OF THE INVENTION

[0002] 1. Field of the Invention

[0003] The present invention relates to a liquid crystal display device, and more particularly, to a liquid crystal display device provided with a sensing electrode for sensing a touch of a user.

[0004] 2. Discussion of the Related Art

[0005] A liquid crystal display device is widely used in various fields of notebook computers, monitors, spacecraft, aircraft, and etc. owing to advantages of low power consumption based on a low driving voltage and portability.

[0006] The liquid crystal display device includes a lower substrate, an upper substrate, and a liquid crystal layer formed between the lower and upper substrates. In the liquid crystal display device, an alignment state of liquid crystal molecules in the liquid crystal layer is controlled based on whether or not an electric field is applied thereto, and light transmittance is controlled according to the alignment state of liquid crystal molecules, whereby images are displayed thereon.

[0007] It is general that a mouse or key board is used as an input means of the liquid crystal display device. However, a touch screen, which can allow a user to directly input information using a finger or pen, is mainly applied to a navigation system, a portable terminal and electric home appliances.

[0008] Hereinafter, a related art liquid crystal display device provided with a touch screen will be described with reference to the accompanying drawings.

[0009] FIG. 1 is a cross-sectional view illustrating the related art liquid crystal display device.

[0010] As shown in FIG. 1, the related art liquid crystal display device includes a liquid crystal panel 10 and a touch screen 20.

[0011] The liquid crystal panel 10 displays images, and includes a lower substrate 12, an upper substrate 14, and a liquid crystal layer 16 formed between these substrates 12 and 14.

[0012] The touch screen 20 is formed on the liquid crystal panel 10 to sense a touch of a user, and includes a touch substrate 22, a first sensing electrode 24 formed below the touch substrate 22, and a second sensing electrode 26 formed over the touch substrate 22.

[0013] The first sensing electrode 24 is arranged below the touch substrate 22 in a horizontal direction, and the second sensing electrode 26 is arranged over the touch substrate 22 in a vertical direction. Accordingly, if the user touches a predetermined position, capacitance between the first sensing electrode 24 and the second sensing electrode 26 is varied at the touched position. As a result, the position where capacitance is varied is sensed, whereby the touch position of the user can be sensed.

[0014] However, in the aforementioned related art liquid crystal display device, since the touch screen 20 is separately formed on the liquid crystal panel 10, the overall thickness of the liquid crystal display device is increased by the touch

screen 20. For this reason, problems occur in that fabricating process steps are complicated and the fabricating cost is increased.

SUMMARY OF THE INVENTION

[0015] Accordingly, the present invention is directed to a liquid crystal display device that substantially obviates one or more problems due to limitations and disadvantages of the related art.

[0016] An advantage of the present invention is to provide a liquid crystal display device in which a sensing electrode for sensing a touch of a user is built in a liquid crystal panel so as not to require a separate touch screen on the liquid crystal panel, whereby the overall thickness of the liquid crystal display device is reduced, fabricating process steps are simplified, and the fabricating cost is reduced.

[0017] Additional advantages and features of the invention will be set forth in part in the description which follows and in part will become apparent to those having ordinary skill in the art upon examination of the following or may be learned from practice of the invention. The objectives and other advantages of the invention may be realized and attained by the structure particularly pointed out in the written description and claims hereof as well as the appended drawings.

[0018] To achieve these objects and other advantages and in accordance with the purpose of the invention, as embodied and broadly described herein, a liquid crystal display device comprises first and second substrates; gate and data lines arranged to cross each other on the first substrate to define a pixel region; a pixel electrode formed in the pixel region; a common electrode forming an electric field together with the pixel electrode and sensing a touch of a user; a light shielding layer formed on the second substrate to shield light leakage to a region other than the pixel region; column spacers formed on the light shielding layer to maintain a cell gap; and a sensing line formed on the column spacers and electrically connected with the common electrode.

[0019] It is to be understood that both the foregoing general description and the following detailed description of the present invention are exemplary and explanatory and are intended to provide further explanation of the invention as claimed.

BRIEF DESCRIPTION OF THE DRAWINGS

[0020] The accompanying drawings, which are included to provide a further understanding of the invention and are incorporated in and constitute a part of this application, illustrate embodiment(s) of the invention and together with the description serve to explain the principle of the invention. In the drawings:

[0021] FIG. 1 is a cross-sectional view illustrating the related art liquid crystal display device;

[0022] FIG. 2a is a plane view illustrating a lower substrate for a liquid crystal display device according to the first embodiment of the present invention, FIG. 2b is a cross-sectional view taken along line A-A of FIG. 2a, FIG. 2c is a plane view illustrating an upper substrate for a liquid crystal display device according to the first embodiment of the present invention, FIG. 2d is a cross-sectional view taken along line B-B of FIG. 2a, and FIG. 2e is a cross-sectional view illustrating a liquid crystal display device according to the first embodiment of the present invention, taken along line C-C of FIG. 2a and FIG. 2c;

[0023] FIG. 3a is a plane view illustrating a lower substrate for a liquid crystal display device according to the second embodiment of the present invention, FIG. 3b is a plane view illustrating an upper substrate for a liquid crystal display device according to the second embodiment of the present invention, and FIG. 3c is a cross-sectional view illustrating a liquid crystal display device according to the second embodiment of the present invention, taken along line C-C of FIG. 3a and FIG. 3b;

[0024] FIG. 4a is a plane view illustrating a lower substrate for a liquid crystal display device according to the third embodiment of the present invention, FIG. 4b is a plane view illustrating an upper substrate for a liquid crystal display device according to the third embodiment of the present invention, and FIG. 4c is a cross-sectional view illustrating a liquid crystal display device according to the third embodiment of the present invention, taken along line C-C of FIG. 4a and FIG. 4b; and

[0025] FIG. 5a is a plane view illustrating a lower substrate for a liquid crystal display device according to the fourth embodiment of the present invention, FIG. 5b is a plane view illustrating an upper substrate for a liquid crystal display device according to the fourth embodiment of the present invention, and FIG. 5c is a cross-sectional view illustrating a liquid crystal display device according to the fourth embodiment of the present invention, taken along line C-C of FIG. 5a and FIG. 5b.

DETAILED DESCRIPTION OF THE INVENTION

[0026] Reference will now be made in detail to the exemplary embodiments of the present invention, examples of which are illustrated in the accompanying drawings. Wherever possible, the same reference numbers will be used throughout the drawings to refer to the same or like parts.

[0027] FIG. 2a is a plane view illustrating a lower substrate for a liquid crystal display device according to the first embodiment of the present invention, FIG. 2b is a cross-sectional view taken along line A-A of FIG. 2a, FIG. 2c is a plane view illustrating an upper substrate for a liquid crystal display device according to the first embodiment of the present invention, FIG. 2d is a cross-sectional view taken along line B-B of FIG. 2a, and FIG. 2e is a cross-sectional view illustrating a liquid crystal display device according to the first embodiment of the present invention, taken along line C-C of FIG. 2a and FIG. 2c.

[0028] Referring to FIG. 2a, especially a partially enlarged view marked with an arrow, the liquid crystal display device according to the first embodiment of the present invention includes a first substrate 100, a gate line 110, a data line 120, a thin film transistor T, a pixel electrode 130, and a common electrode 140.

[0029] The gate line 110 is arranged on the substrate 100 in a first direction, for example, X axis direction, and the data line 120 is arranged on the substrate 100 in a second direction, for example, Y axis direction. In this way, the gate line 110 and the data line 120 cross each other to define a plurality of pixel regions. Although the gate line 110 and the data line 120 are arranged in a straight line as shown, they may be arranged in a bent line.

[0030] The thin film transistor T is a switching element, and is formed in a region where the gate line 110 and the data line 120 cross each other. The thin film transistor T includes a gate electrode 112, a semiconductor layer 117, a source electrode 122 and a drain electrode 124. The gate electrode 112 is

extended from the gate line 110, the source electrode 122 is extended from the data line 120, and the drain electrode 124 faces the source electrode 122.

[0031] The aforementioned thin film transistor T may have various structures such as a bottom gate structure where the gate electrode 112 is arranged below the semiconductor layer 117 and a top gate structure where the gate electrode 112 is arranged over the semiconductor layer 117. Also, various modifications may be made in types of the respective electrodes.

[0032] The pixel electrode 130 is formed in each of the pixel regions, and is electrically connected with the drain electrode 124 of the thin film transistor T. Particularly, although the pixel electrode 130 may directly be connected with the drain electrode 124, it is not limited to the above example.

[0033] The common electrode 140 serves to drive the liquid crystal layer by forming an electric field together with the pixel electrode 130. Particularly, the common electrode 140 includes one or more slits 145 in the pixel region. Accordingly, a fringe field is formed between the pixel electrode 130 and the common electrode 140 through the slits 145, and the liquid crystal may be driven by the fringe field.

[0034] FIG. 2b corresponds to a section of the pixel region taken in a vertical direction. As shown in FIG. 2b, the gate electrode 112 is formed on the first substrate 100, and a gate insulating film 115 is formed on the gate electrode 112. Also, the semiconductor layer 117 is formed on the gate insulating film 115, and the source electrode 122 and the drain electrode 124 are formed on the semiconductor layer 117 while facing each other.

[0035] The pixel electrode 130 is formed on the drain electrode 124. In this way, the drain electrode 124 and the pixel electrode 130 are directly connected with each other. Meanwhile, although the pixel electrode 130 may be extended to the upper surface of the drain electrode 124 as shown, the pixel electrode 130 may be extended to the lower surface of the drain electrode 124.

[0036] A passivation film 125 is formed on the pixel electrode 130, and the common electrode 140 is formed on the passivation film 125.

[0037] Since the common electrode 140 includes one or more slits 145, a fringe field may be formed between the pixel electrode 130 and the common electrode 140 through the slit 145.

[0038] Meanwhile, the common electrode 140 serves to drive the liquid crystal by forming the electric field together with the pixel electrode 130 as described above and also serves as a sensing electrode for sensing a touch position of a user. In order to serve as the sensing electrode, the common electrode 140 is not formed on the entire surface of the substrate 100 but formed in a predetermined pattern.

[0039] In other words, as shown in FIG. 2a, the common electrode 140 includes a plurality of first common electrodes 141 and a plurality of second common electrodes 142. At this time, a position of Y axis touched by the user may be sensed by the first common electrodes 141, and a position of X axis touched by the user may be sensed by the second common electrodes 142.

[0040] The sizes of the first and second common electrodes 141 and 142 may be formed appropriately considering a touch surface of a finger or pen. For example, the first common electrode 141 may be formed to include several tens of pixels or several hundreds of pixels.

[0041] Hereinafter, the first and second common electrodes 141 and 142 serving as the sensing electrodes will be described in more detail.

[0042] First of all, in order to sense the position of the X axis touched by the user, the plurality of second common electrodes 142 are spaced apart from one another at predetermined intervals in X axis direction. Also, the second common electrodes 142 are longitudinally formed in Y axis direction.

[0043] Accordingly, if the user touches a predetermined position, the second common electrode 142 of which capacitance is varied, is recognized among the plurality of second common electrodes 142. As a result, the position of the X axis touched by the user can be sensed.

[0044] Next, in order to sense the position of the Y axis touched by the user, the plurality of first common electrodes 141 are spaced apart from one another at predetermined intervals in Y axis direction. However, if the first common electrodes 141 are longitudinally formed in X axis direction, the first common electrode 141 and the second common electrode 142 are electrically connected with each other, whereby the positions of the X axis and the Y axis touched by the user cannot be sensed. Accordingly, the first common electrodes 141 are not formed longitudinally in X axis direction but spaced apart from one another at predetermined intervals in X axis direction. In other words, as shown, the second common electrode 142 is formed between the first common electrodes 141 in X axis direction, whereas the second common electrode 142 is not formed between the first common electrodes 141 in Y axis direction.

[0045] Since the plurality of first common electrodes 141 are spaced apart from one another at predetermined intervals in X axis direction by interposing the second common electrode 142 therebetween as described above, it is required that the plurality of first common electrodes 141 are electrically connected with one another. Electrical connection of the first common electrodes 141 arranged in X axis direction will be made through a sensing line 250 formed in the upper substrate 200, which will be described later.

[0046] Referring to FIG. 2c, especially a partially enlarged view marked with an arrow and FIG. 2d, the upper substrate for the liquid crystal display device according to the first embodiment of the present invention includes a second substrate 200, light shielding layers 210, color filter layers 220, an overcoat layer 230, column spacers 240, and a sensing line 250.

[0047] The light shielding layers 210 serve to shield light leakage to a region other than the pixel region, and is formed on the second substrate 200 in a matrix arrangement.

[0048] The color filter layers 220 are formed between the light shielding layers 210, and include color filters of red R, green G, and blue B.

[0049] The overcoat layer 230 is formed on the color filter layer 220, and serves to make the surface of the substrate flat.

[0050] The column spacers 240 are formed on the overcoat layer 230, and serve to maintain a cell gap of the liquid crystal display device. The column spacers 240 are formed in regions corresponding to the light shielding layers 210 to prevent light transmittance from being reduced.

[0051] As described above, the sensing line 250 serves to electrically connect the first common electrodes 141 formed on the first substrate 100 for the liquid crystal display device with one another.

[0052] In FIG. 2c, the elements of the first substrate 100 for the liquid crystal display device are marked with a dotted line.

Referring to FIG. 2c, the sensing line 250 is extended in X direction to electrically connect the first common electrodes 141 with one another.

[0053] Accordingly, if the user touches a predetermined position, the sensing line 250 recognizes the first common electrode 141 of which capacitance is varied, among the plurality of first common electrodes 141. As a result, the position of the Y axis touched by the user can be sensed.

[0054] Meanwhile, although the sensing line 250 serves to electrically connect the first common electrodes 141 arranged in X axis direction with one another, the first common electrode 141 should not be connected with the second common electrode 142 electrically due to the sensing line 250. Accordingly, although the sensing line 250 is electrically connected with the first common electrodes 141, it is not connected with the second common electrodes 142 electrically.

[0055] In more detail, the sensing line 250 is connected with the common electrodes 140 through the column spacers 240. For this, although the column spacers 240 are formed in a region of the first common electrodes 141, through which the sensing line 250 passes, they are not formed in a region of the second common electrodes, through which the sensing line 250 passes. Accordingly, the sensing line 250 is electrically connected with the first common electrodes 141 through the column spacers 240 but is not connected with the second common electrodes 142 electrically.

[0056] The method for electrically connecting the sensing line 250 with the first common electrodes 141 through the column spacers 240 will be understood more easily with reference to FIG. 2e.

[0057] FIG. 2e corresponds to a section of the gate line 110 of FIG. 2a and the region for the light shielding layers 210 of FIG. 2c taken in a vertical direction. As shown in FIG. 2e, the gate line 110 is formed on the first substrate 100, and a gate insulating film 115 is formed on the gate line 110. Also, the data line 120 is formed on the gate insulating film 115 at a predetermined interval, and a passivation film 125 is formed on the data line 120. Moreover, the first common electrode 141 and the second common electrode 142 are alternately formed on the passivation film 125.

[0058] Also, the light shielding layers 210 are formed on the second substrate 200, and the color filter layers 220 are formed on the light shielding layers 210. The overcoat layer 230 is formed on the color filter layers 220, the column spacers 240 are formed on the overcoat layer 230, and the sensing line 250 is formed on the column spacers 240.

[0059] At this time, since the column spacers 240 are formed in the region corresponding to the first common electrodes 141, the sensing line 250 formed on the column spacers 240 is electrically connected with the first common electrodes 141 but is not electrically connected with the second common electrodes 142.

[0060] Referring to FIG. 2c again, although one sensing line 250 is connected with the first common electrodes 141 as shown, a plurality of sensing lines 250 may be connected with the first common electrodes 141. Particularly, since a transparent conductive oxide having high resistance such as ITO is generally used as the first common electrode 141, the plurality of sensing lines 250 of metal having excellent electric conductivity are preferably connected with the first common electrode 141 to reduce resistance.

[0061] Meanwhile, if the sensing line 250 is formed of opaque metal having excellent electric conductivity to reduce resistance, light transmittance may be reduced due to the

sensing line 250. Accordingly, the sensing line 250 is preferably formed in a non-transmissive region through which light is not transmitted, to prevent light transmittance from being reduced. Namely, as shown in the partially enlarged view of FIG. 2c, the sensing line 250 is preferably formed in a region corresponding to the light shielding layers 210.

[0062] Also, although the first common electrodes 141 are connected with the sensing line 250 through the two column spacers 240 as shown, they may be connected with the sensing line 250 through one column spacer 240 or three or more column spacers 240. However, in order to reduce resistance, it is preferable to increase the number of the column spacers 240.

[0063] It has been described that the second common electrodes 142 are longitudinally arranged in Y axis direction and the first common electrodes 141 are connected with the sensing line 250 in X axis direction. However, the second common electrodes 142 may longitudinally be arranged in X axis direction, and the first common electrodes 141 may be connected with the sensing line 250 in Y axis direction.

[0064] Although not shown, the liquid crystal layer is formed between the first substrate 100 and the second substrate 200.

[0065] Meanwhile, the aforementioned liquid crystal display device according to the first embodiment of the present invention may be driven by a projected cap mode such as a self cap mode or a mutual cap mode.

[0066] The projected cap mode allows the user to sense the positions of the X axis and the Y axis by sensing capacitance varied between the first common electrode 141 and the second common electrode 142 if the user touches a predetermined position. The projected cap mode may be divided into a self cap mode and a mutual cap mode depending on a voltage mode applied to the electrodes 141 and 142.

[0067] The self cap mode is to sense the positions of the X axis and the Y axis by sensing capacitance variation between the first common electrode 141 and the second common electrode 142 when the user touches a predetermined position after simultaneously applying a voltage to the sensing lines 250 connecting the first common electrodes 141.

[0068] By contrast, the mutual cap mode is to sense the positions of the X axis and the Y axis by sensing capacitance variation between the first common electrode 141 and the second common electrode 142 when the user touches a predetermined position after applying a voltage to the sensing lines 250, which connects the first common electrodes 141, in accordance with a time gap. In other words, the mutual cap mode means that the sensing line 250 serves as a transmission line and the common electrode 142 serves as a reception line, and has recently received more attention than the self cap mode.

[0069] FIG. 3a is a plane view illustrating a lower substrate for a liquid crystal display device according to the second embodiment of the present invention, FIG. 3b is a plane view illustrating an upper substrate for a liquid crystal display device according to the second embodiment of the present invention, and FIG. 3c is a cross-sectional view illustrating a liquid crystal display device according to the second embodiment of the present invention, taken along line C-C of FIG. 3a and FIG. 3b.

[0070] The liquid crystal display device according to the second embodiment of the present invention as shown in FIG. 3a to FIG. 3c is the same as that according to the first embodiment of the present invention except that a conductive line

150 is additionally connected with the second common electrodes 142 on the first substrate 100. Accordingly, the same reference numbers will be used throughout the drawings to refer to the same or like parts, and detailed description of the same or like parts will be omitted.

[0071] As shown in FIG. 3a, according to the second embodiment of the present invention, the conductive line 150 is connected with the second common electrodes 142 on the first substrate 100.

[0072] A transparent conductive oxide such as ITO is generally used as the second common electrode 142. The transparent conductive oxide has a problem in that resistance is high. Accordingly, in the second embodiment of the present invention, the conductive line 150 of a metal having excellent electric conductivity is connected with the second common electrode 142 to reduce resistance of the second common electrode 142.

[0073] The conductive line 150 may directly be connected with the second common electrode 142. Also, the conductive line 150 may be extended in a length direction of the second common electrode 142, i.e., Y axis direction. However, if the second common electrode 142 is longitudinally extended in X axis direction, the conductive line 150 may also longitudinally be extended in X axis direction.

[0074] If the conductive line 150 is formed of opaque metal, light transmittance may be reduced due to the conductive line 150. Accordingly, the conductive line 150 is preferably formed in a non-transmissive region through which light is not transmitted, to prevent light transmittance from being reduced. Namely, as shown in the partially enlarged view of FIG. 3a, the conductive line 150 is preferably formed in a region corresponding to the data line 120. The conductive line 150 may be formed in a region corresponding to the gate line 110 as the case may be.

[0075] Although one conductive line 150 is connected with the second common electrode 142 as shown, it is preferable that a plurality of conductive lines 150 are connected with the second common electrode 142 to minimize resistance of the second common electrode 142.

[0076] FIG. 3b is a plane view illustrating an upper substrate for a liquid crystal display device according to the second embodiment of the present invention. In FIG. 3b, the elements of the first substrate 100 for the liquid crystal display device are marked with a dotted line. Since the upper substrate for the liquid crystal display device according to the second embodiment of the present invention is the same as that for the liquid crystal display device according to the first embodiment of the present invention, its repeated description will be omitted.

[0077] FIG. 3c is a cross-sectional view illustrating a liquid crystal display device according to the second embodiment of the present invention. As shown in FIG. 3c, a gate line 110 is formed on the substrate 100, and a gate insulating film 115 is formed on the gate line 110. Also, data lines 120 are formed on the gate insulating film 115 at predetermined intervals, and a passivation film 125 is formed on the data lines 120. The first common electrode 141 and the second common electrode 142 are alternately formed on the passivation film 125, and the conductive line 150 is formed on the second common electrode 142.

[0078] The conductive line 150 may be formed below the second common electrode 142. In other words, the conduc-

tive line 150 may be formed over the passivation film 125 and the second common electrode 142 may be formed over the conductive line 150.

[0079] Also, the light shielding layer 210 is formed on the second substrate 200, and the color filter layer 220 is formed on the light shielding layer 210. The overcoat layer 230 is formed on the color filter layer 220, the column spacers 240 are formed on the overcoat layer 230, and the sensing line 250 is formed on the column spacers 240.

[0080] At this time, since the column spacers 240 are formed in the region corresponding to the first common electrodes 141, the sensing line 250 formed on the column spacers 240 is electrically connected with the first common electrodes 141 but is not electrically connected with the second common electrodes 142.

[0081] FIG. 4a is a plane view illustrating a lower substrate for a liquid crystal display device according to the third embodiment of the present invention, FIG. 4b is a plane view illustrating an upper substrate for a liquid crystal display device according to the third embodiment of the present invention, and FIG. 4c is a cross-sectional view illustrating a liquid crystal display device according to the third embodiment of the present invention, taken along line C-C of FIG. 4a and FIG. 4b.

[0082] The liquid crystal display device according to the third embodiment of the present invention as shown in FIG. 4a to FIG. 4c is the same as that according to the first embodiment of the present invention except that column spacers 240 and a sensing line 250 are changed. Accordingly, the same reference numbers will be used throughout the drawings to refer to the same or like parts, and detailed description of the same or like parts will be omitted.

[0083] Since the lower substrate for the liquid crystal display device according to the third embodiment of the present invention as shown in FIG. 4a is the same as that for the liquid crystal display device according to the first embodiment of the present invention, its repeated description will be omitted.

[0084] As shown in FIG. 4b, according to the third embodiment of the present invention, the sensing line 250 is not formed in a straight line but extended around the predetermined column spacer 240.

[0085] According to the aforementioned first embodiment of the present invention, the sensing line 250 is formed in a straight line, and the column spacers 240 are formed on the sensing line 250. At this time, the column spacers 240 are formed in the region corresponding to the first common electrodes 141 but are not formed in the region corresponding to the second common electrodes 142. As a result, the sensing line 250 is electrically connected with the first common electrodes 141 but is not electrically connected with the second common electrodes 142.

[0086] However, according to the third embodiment of the present invention, the column spacers 240 are arranged in a line. At this time, the column spacers 240 are formed in the region corresponding to the first common electrodes 141 and the region corresponding to the second common electrodes 142. Accordingly, in this case, if the sensing line 250 is formed in a straight line in the same manner as the first embodiment, the first common electrodes 141 are electrically connected with the second common electrodes 142 by the sensing line 250, whereby short occurs.

[0087] Accordingly, in the third embodiment of the present invention, in order that the sensing line 250 is electrically connected with the first common electrodes 141 but is not

electrically connected with the second common electrodes 142, the sensing line 250 is extended around the column spacers 240 formed in the region corresponding to the second common electrodes 142.

[0088] FIG. 4c is a cross-sectional view illustrating a liquid crystal display device according to the third embodiment of the present invention. As shown in FIG. 4c, a gate line 110 is formed on the substrate 100, and a gate insulating film 115 is formed on the gate line 110. Also, data lines 120 are formed on the gate insulating film 115 at predetermined intervals, and a passivation film 125 is formed on the data lines 120. The first common electrode 141 and the second common electrode 142 are alternately formed on the passivation film 125.

[0089] Also, the light shielding layer 210 is formed on the second substrate 200, and the color filter layer 220 is formed on the light shielding layer 210. The overcoat layer 230 is formed on the color filter layer 220, the column spacers 240 are formed on the overcoat layer 230, and the sensing line 250 is formed on the column spacers 240.

[0090] At this time, the column spacers 240 are formed in the region corresponding to the first common electrodes 141 and the region corresponding to the second common electrodes 142. However, since the sensing line 250 is formed only on the column spacers 240 formed in the region corresponding to the first common electrodes 141, it is electrically connected with the first common electrodes 141 but is not electrically connected with the second common electrodes 142.

[0091] Meanwhile, since the column spacers 240 serve to maintain a cell gap of the liquid crystal display device, it is preferable that a separate layer 255 for the cell gap is formed on the column spacers 240 formed in the region corresponding to the second common electrodes 142. In this case, the separate layer 255 for the cell gap may be formed of the same material as that of the sensing line 250 by the same process as that of the sensing line.

[0092] FIG. 5a is a plane view illustrating a lower substrate for a liquid crystal display device according to the fourth embodiment of the present invention, FIG. 5b is a plane view illustrating an upper substrate for a liquid crystal display device according to the fourth embodiment of the present invention, and FIG. 5c is a cross-sectional view illustrating a liquid crystal display device according to the fourth embodiment of the present invention, taken along line C-C of FIG. 5a and FIG. 5b.

[0093] The liquid crystal display device according to the fourth embodiment of the present invention as shown in FIG. 5a to FIG. 5c is the same as that according to the third embodiment of the present invention except that a conductive line 150 is additionally connected with the second common electrodes 142 on the first substrate 100. Accordingly, the same reference numbers will be used throughout the drawings to refer to the same or like parts, and detailed description of the same or like parts will be omitted.

[0094] As shown in FIG. 5a, according to the fourth embodiment of the present invention, since the conductive line 150 is connected with the second common electrodes 142 on the first substrate 100, resistance of the second common electrodes 142 may be reduced.

[0095] The conductive line 150 may directly be connected with the second common electrode 142. Also, the conductive line 150 may be extended longitudinally in a length direction of the second common electrode 142.

[0096] If the conductive line 150 is formed of opaque metal, light transmittance may be reduced due to the conductive line 150. Accordingly, the conductive line 150 is preferably formed in a non-transmissive region through which light is not transmitted, to prevent light transmittance from being reduced. Namely, the conductive line 150 may be formed in a region corresponding to the data line 120 or the gate line 110.

[0097] A plurality of conductive lines 150 may be connected with the second common electrodes 142 to minimize resistance of the second common electrodes 142.

[0098] FIG. 5b is a plane view illustrating an upper substrate for a liquid crystal display device according to the fourth embodiment of the present invention. In FIG. 5b, the elements of first substrate 100 for the liquid crystal display device are marked with a dotted line. Since the upper substrate for the liquid crystal display device according to the fourth embodiment of the present invention is the same as that for the liquid crystal display device according to the third embodiment of the present invention, its repeated description will be omitted.

[0099] FIG. 5c is a cross-sectional view illustrating a liquid crystal display device according to the fourth embodiment of the present invention. As shown in FIG. 5c, a gate line 110 is formed on the substrate 100, and a gate insulating film 115 is formed on the gate line 110. Also, data lines 120 are formed on the gate insulating film 115 at predetermined intervals, and a passivation film 125 is formed on the data lines 120. The first common electrode 141 and the second common electrode 142 are alternately formed on the passivation film 125, and the conductive line 150 is formed on the second common electrode 142.

[0100] The conductive line 150 may be formed below the second common electrode 142. In other words, the conductive line 150 may be formed over the passivation film 125 and the second common electrode 142 may be formed over the conductive line 150.

[0101] Also, the light shielding layer 210 is formed on the second substrate 200, and the color filter layer 220 is formed on the light shielding layer 210. The overcoat layer 230 is formed on the color filter layer 220, the column spacers 240 are formed on the overcoat layer 230, and the sensing line 250 is formed on the column spacers 240.

[0102] At this time, the column spacers 240 are formed in the region corresponding to the first common electrodes 141 and the region corresponding to the second common electrodes 142. However, since the sensing line 250 is formed only on the column spacers 240 formed in the region corresponding to the first common electrodes 141, it is electrically connected with the first common electrodes 141 but is not electrically connected with the second common electrodes 142.

[0103] Also, a separate layer 255 for a cell gap may be formed on the column spacers 240 formed in the region corresponding to the second common electrodes 142. In this case, the layer 255 for the cell gap may be formed of the same material as that of the sensing line 250 by the same process as that of the sensing line 250.

[0104] As described above, the liquid crystal display device according to the present invention has the following advantages.

[0105] Since the common electrode used to form an electric field for driving a liquid crystal is used as a sensing electrode for sensing a touch of a user, a separate touch screen on the liquid crystal panel is not required unlike the related art,

whereby the overall thickness of the liquid crystal display device is reduced, fabricating process steps are simplified, and the fabricating cost is reduced.

[0106] It will be apparent to those skilled in the art that various modifications and variations can be made in the present invention without departing from the spirit or scope of the inventions. Thus, it is intended that the present invention covers the modifications and variations of this invention provided they come within the scope of the appended claims and their equivalents.

What is claimed is:

1. A liquid crystal display device comprising:

first and second substrates;

gate and data lines arranged to cross each other on the first substrate to define a pixel region;

a pixel electrode formed in the pixel region;

a common electrode forming an electric field together with the pixel electrode and sensing a touch of a user;

a light shielding layer formed on the second substrate to shield light leakage to a region other than the pixel region;

column spacers formed on the light shielding layer to maintain a cell gap; and

a sensing line formed on the column spacers and electrically connected with the common electrode.

2. The liquid crystal display device of claim 1, wherein the pixel electrode is formed below a passivation film, and the common electrode is formed over the passivation film and includes one or more slits in the pixel region.

3. The liquid crystal display device of claim 1, wherein the common electrode includes a plurality of first common electrodes for sensing any one of a touch position of X axis and a touch position of Y axis and a plurality of second common electrodes for sensing the other one of the touch positions of X axis and Y axis, and the sensing line is not electrically connected with the plurality of second common electrodes but electrically connected with the plurality of first common electrodes.

4. The liquid crystal display device of claim 3, wherein the sensing line is formed in a straight line, and the column spacers are formed in a region corresponding to the first common electrodes on the sensing line but are not formed in a region corresponding to the second common electrodes.

5. The liquid crystal display device of claim 3, wherein the column spacers are arranged in the region corresponding to the first common electrodes and the region corresponding to the second common electrodes, and the sensing line is not formed in a straight line but extended around the column spacers formed in the region corresponding to the second common electrodes.

6. The liquid crystal display device of claim 5, wherein a layer for a cell gap is additionally formed on the column spacers formed in the region corresponding to the second common electrodes.

7. The liquid crystal display device of claim 3, wherein each of the second common electrodes is longitudinally

extended in X axis direction or Y axis direction, and the respective first common electrodes are spaced apart from each other by interposing the second common electrodes therebetween, and the sensing line is extended in a direction crossing the extended direction of the second common electrodes.

8. The liquid crystal display device of claim 1, wherein the sensing line is formed in a region corresponding to the light shielding layer.

9. The liquid crystal display device of claim 1, further comprising a conductive line electrically connected with the second common electrodes to reduce resistance of the second common electrodes.

10. The liquid crystal display device of claim 9, wherein the conductive line is formed in a region corresponding to the gate line or the data line.

* * * * *

专利名称(译)	液晶显示装置		
公开(公告)号	US20120086665A1	公开(公告)日	2012-04-12
申请号	US13/244988	申请日	2011-09-26
[标]申请(专利权)人(译)	宋INHYUK		
申请(专利权)人(译)	宋INHYUK		
当前申请(专利权)人(译)	宋INHYUK		
[标]发明人	SONG INHYUK		
发明人	SONG, INHYUK		
IPC分类号	G09G3/36 G06F3/045 G06F3/041		
CPC分类号	G02F1/13338 G06F3/0412 G02F1/136209 G02F1/1339		
优先权	1020100098256 2010-10-08 KR		
其他公开文献	US8878814		
外部链接	Espacenet USPTO		

摘要(译)

公开了一种液晶显示装置，包括第一和第二基板；栅极和数据线布置成在第一基板上彼此交叉以限定像素区域；形成在像素区域中的像素电极；公共电极与像素电极一起形成电场并感测用户的触摸；形成在第二基板上的遮光层，用于屏蔽漏光到除像素区域以外的区域；在光屏蔽层上形成柱状间隔物以保持单元间隙；以及形成在柱状衬垫料上并与公共电极电连接的传感线。

