



US008558963B2

(12) **United States Patent**
Li

(10) **Patent No.:** **US 8,558,963 B2**
(45) **Date of Patent:** **Oct. 15, 2013**

(54) **FIXED STRUCTURE FOR LIQUID CRYSTAL DISPLAY DEVICE AND LIQUID CRYSTAL DISPLAY DEVICE THEREOF**

(75) Inventor: **Quan Li**, Shenzhen (CN)

(73) Assignee: **Shenzhen China Star Optoelectronics Technology Co., Ltd.**, Shenzhen (CN)

(*) Notice: Subject to any disclaimer, the term of this patent is extended or adjusted under 35 U.S.C. 154(b) by 238 days.

(21) Appl. No.: **13/148,410**

(22) PCT Filed: **Jun. 10, 2011**

(86) PCT No.: **PCT/CN2011/075563**

§ 371 (c)(1),
(2), (4) Date: **Aug. 8, 2011**

(87) PCT Pub. No.: **WO2012/145956**

PCT Pub. Date: **Nov. 1, 2012**

(65) **Prior Publication Data**

US 2013/0208208 A1 Aug. 15, 2013

(30) **Foreign Application Priority Data**

Apr. 26, 2011 (CN) 2011 2 0126823 U

(51) **Int. Cl.**
G02F 1/1333 (2006.01)
G02F 1/1335 (2006.01)

(52) **U.S. Cl.**
USPC **349/58**; 349/64

(58) **Field of Classification Search**
USPC 349/58-65
See application file for complete search history.

(56) **References Cited**

U.S. PATENT DOCUMENTS

2004/0008512 A1*	1/2004	Kim	362/235
2005/0151894 A1*	7/2005	Katsuda et al.	349/58
2007/0085943 A1*	4/2007	Kang et al.	349/65
2007/0132905 A1*	6/2007	Kim et al.	349/58
2007/0171323 A1*	7/2007	Lin	349/58
2007/0216825 A1*	9/2007	Hsu et al.	349/58
2008/0278656 A1*	11/2008	Yuan	349/58

* cited by examiner

Primary Examiner — Bumsuk Won

Assistant Examiner — Charles Chang

(74) *Attorney, Agent, or Firm* — Xin (Kevin) He, Esq.; Troutman Sanders LLP

(57) **ABSTRACT**

The invention claims a fixed structure for the liquid crystal display device and a liquid crystal display device thereof. Said liquid crystal display device includes a liquid crystal panel and a backlight module. Said fixed structure includes a main-body rubber frame and a front frame fixed on the outer side of the main-body rubber frame. Said main-body rubber frame comprises a groove and a support chip. Said support chip supports the liquid crystal panel thereon. Said backlight module is arranged into the main-body rubber frame and lies below the support chip. Said front frame includes an edge frame and a fixed frame. Said edge frame comprises a first clamping part and a bulge matched with said groove. Said fixed frame comprises a second clamping part. Said first clamping part and said second clamping part as well as said support chip are used for clamping and fixing said liquid crystal panel. While assembling this invention, it only needs to insert the bulge of the edge frame for the front frame into the groove of the main-body rubber frame and then fix the fixed frame on the main-body rubber frame by screws; as a result, it simplifies the assembly process for the liquid crystal display module. Additionally, since the edge frame is made of plastic cement so that the weight of the liquid crystal display module is reduced.

18 Claims, 2 Drawing Sheets

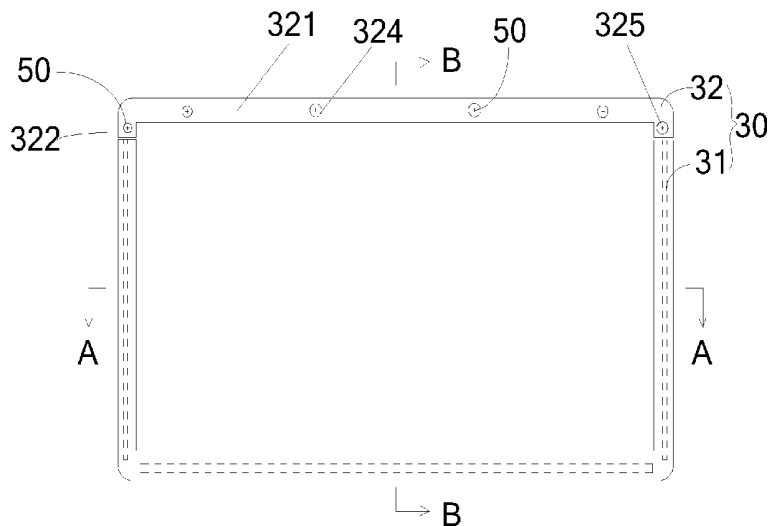

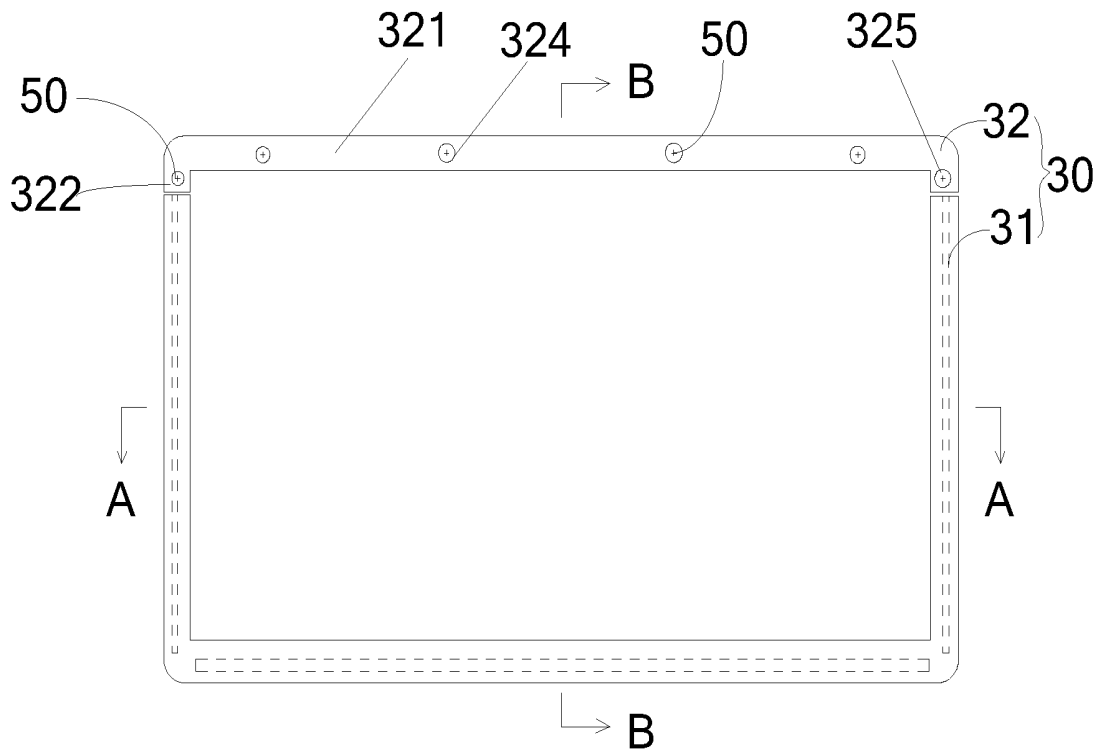

FIG. 1

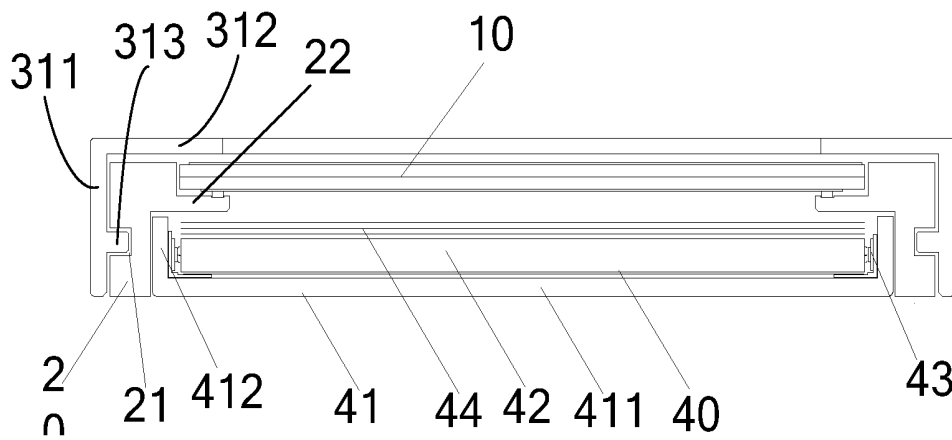

FIG. 2

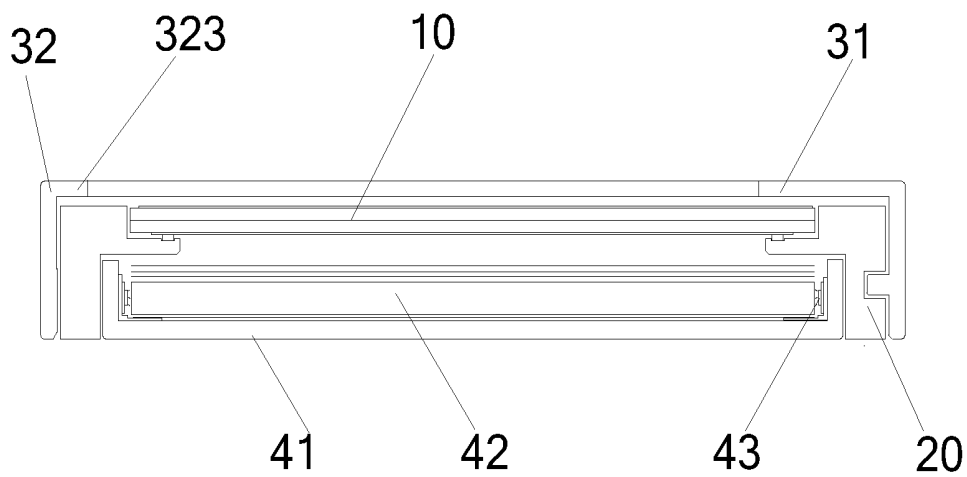

FIG. 3

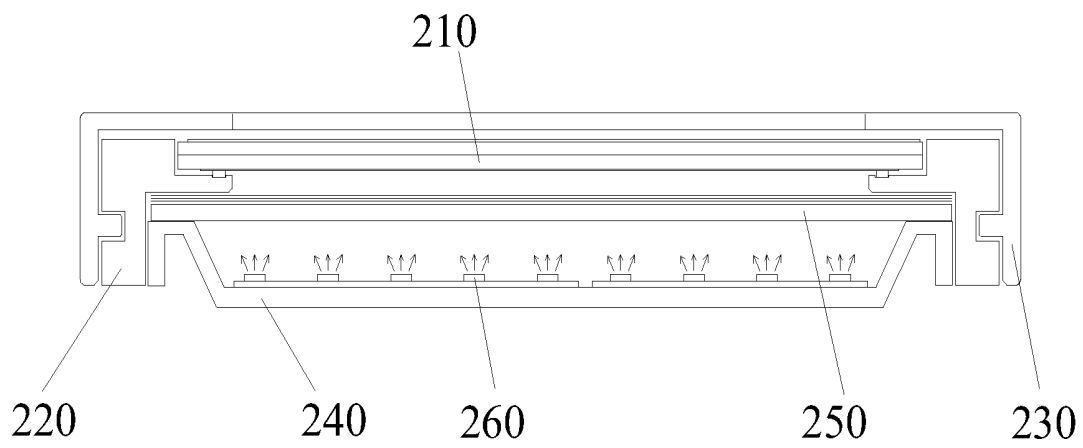

FIG. 4

**FIXED STRUCTURE FOR LIQUID CRYSTAL
DISPLAY DEVICE AND LIQUID CRYSTAL
DISPLAY DEVICE THEREOF**

BENEFIT CLAIMS

This application is a US National Stage of International Application No. PCT/CN2011/075563, filed Jun. 10, 2011, which claims the benefit of CN 201120126823.0 filed Apr. 26, 2011.

FIELD OF THE INVENTION

The invention relates to the technical filed of the liquid crystal display device, particularly to a fixed structure for the liquid crystal display device and the liquid crystal display device thereof.

BACKGROUND OF THE INVENTION

The traditional TFT-LCD (Thin Film Transistor Liquid Crystal Display) includes a backlight module, a liquid crystal panel, a rubber frame and a front frame. Said backlight module includes a metal back panel, a light guide plate, an optical membrane unit, a light source, etc. Said light guide plate is arranged into the metal back panel. Said light source is arranged on the metal back panel and lies on one side of the light guide plate. Said optical membrane unit is overlapped on the light guide plate. Said rubber frame is arranged on said metal back panel and encircles said metal back panel; said liquid crystal panel is arranged on said rubber frame; said front frame is assembled on said rubber frame and integrated with said rubber frame to clamp and fix the liquid crystal panel so as to protect the liquid crystal panel.

The front frame in present technology generally refers to the integrally-molded metal frame; as a result, more screws are needed to lock the metal front frame for the large-sized module; therefore, it will cost more working hours to process the assembling; additionally, the weight of the metal front frame is heavier, which is not beneficial for the lightweight design of the liquid crystal display device.

SUMMARY OF THE INVENTION

The main purpose of the invention is to provide a fixed structure for the liquid crystal display device and the liquid crystal display device thereof, which aims to reduce the weight of the liquid crystal display module and simplify the assembling process.

In order to achieve the above mentioned purpose, thus the invention discloses a fixed structure for the liquid crystal display device. Said liquid crystal display device includes a liquid crystal panel and a backlight module. Said fixed structure includes a main-body rubber frame and a front frame fixed on the outer side of the main-body rubber frame. Said main-body rubber frame comprises a groove and a support chip. Said support chip is used for supporting the liquid crystal panel thereon. Said backlight module is arranged into the main-body rubber frame and lies below the support chip. Said front frame comprises an edge frame and a fixed frame. Said edge frame comprises a first clamping part and a bulge matched with said groove. Said fixed frame comprises a fixed edge frame and two joint frames that are arranged on the two ends of the fixed edge frame and connect to the fixed edge frame vertically. Both said fixed edge frame and said joint frames internally form a second clamping part; said first

clamping part and said second clamping part as well as said support chip are used for clamping and fixing said liquid crystal panel.

Preferably, said fixed frame is made of metal material. The fixed edge frame of said fixed frame is arranged on the outer side of the uncombined edge frame of the main-body rubber frame. Said joint frames are arranged on the outer side of said main-body rubber frame and are partly overlapped with one end part of the edge frame.

Preferably, said main-body rubber frame is opened with first locking holes. The two ends of said edge frame are opened with second locking holes. Said fixed edge frame is opened with third locking holes, and said joint frames are opened with fourth locking holes. Multiple screws penetrate through said third locking holes and said first locking holes to fix said fixed frame on the main-body rubber frame; multiple screws penetrate through said fourth locking holes, said second locking holes and said first locking holes to simultaneously fix said edge frame and said fixed frame on said main-body rubber frame.

Preferably, said main-body rubber frame is a square frame shape. Said groove is arranged on the outer side of said main-body rubber frame. Said support chip is arranged on the inner side of said main-body rubber frame and is internally protruded.

Preferably, said edge frame is arranged on the outer side of said main-body rubber frame in order to encircle the three sides of said main-body rubber frame; and the bulge of said edge frame is clamped into the groove of said main-body rubber frame.

Preferably, said edge frame is integrally molded by the plastic cement; and said edge frame is integrally Π -shaped.

Preferably, said edge frame comprises a side wall. The upper end of said side wall is internally and vertically extended with said first clamping part. The middle part of said side wall is internally and vertically extended with said bulge.

Preferably, the surface of said support chip that lies above the light source is formed with a reflection layer. Said reflection layer is a surface layer formed by the method of two-color molding with the function of reflection or it is a reflection layer plated with metals.

The invention further discloses a fixed structure for the liquid crystal display device, wherein said liquid crystal display device includes a liquid crystal panel and a backlight module; said fixed structure includes a main-body rubber frame and a front frame fixed on the outer side of the main-body rubber frame. Said main-body rubber frame comprises a groove and a support chip. Said support chip is supports the liquid crystal panel thereon; said backlight module is arranged into the main-body rubber frame and lies below the support chip. Said front frame includes an edge frame and a fixed frame. Said edge frame comprises a first clamping part and a bulge matched with said groove. Said fixed frame includes a second clamping part; said first clamping part and said second clamping part as well as said support chip are used for clamping and fixing said liquid crystal panel.

Preferably, said main-body rubber frame is a square frame shape. Said groove is arranged on the outer side of said main-body rubber frame; said support chip is arranged on the inner side of said main-body rubber frame and is internally protruded.

Preferably, said edge frame is arranged on the outer side of said main-body rubber frame in order to encircle the three sides of said main-body rubber frame; and the bulge of said edge frame is clamped into the groove of said main-body rubber frame.

Preferably, said edge frame is integrally molded by the plastic cement; and said edge frame is integrally Π -shaped

Preferably, said edge frame comprises a side wall. The upper end of said side wall is internally and vertically extended with said first clamping part. The middle part of said side wall is internally and vertically extended with said bulge.

Preferably, the surface of said support chip that lies above the light source is formed with a reflection layer. Said reflection layer is a surface layer formed by the method of two-color molding with the function of reflection or it is a reflection layer plated with metals.

Preferably, said backlight module includes a back panel, a light guide plate, a light source and an optical membrane unit. Said back panel includes a bottom plate and a side wall. Said light guide plate is arranged on the bottom plate of the back panel. Said light source is arranged on the side wall of said back panel. Said optical membrane unit is arranged above the light guide plate.

Preferably, said light source lies on the opposite two sides of said light guide plate.

Preferably, said backlight module includes a back panel, a diffusion plate and a light source; said back panel includes a bottom plate and a side wall. Said light source is arranged on the bottom plate of said back panel, and said diffusion plate is arranged on the top part of the side wall of said back panel.

The invention further discloses a liquid crystal display device, wherein said liquid crystal display device includes a fixed structure, a liquid crystal panel and a backlight module. Said liquid crystal panel is clamped into said fixed structure. Said backlight module is arranged into said fixed structure and lies below said liquid crystal panel. Said fixed structure includes a main-body rubber frame and a front frame fixed on the outer side of the main-body rubber frame. Said main-body rubber frame comprises a groove and a support chip. Said support chip supports the liquid crystal panel thereon. Said backlight module is arranged into said main-body rubber frame and lies below the support chip. Said front frame includes an edge frame and a fixed frame. Said edge frame comprises a first clamping part and a bulge matched with said groove. Said fixed frame includes a second clamping part. Said first clamping part and said second clamping part as well as said support chip are used for clamping and fixing said liquid crystal panel.

Preferably, said backlight module includes a back panel, a light guide plate, a light source and an optical membrane unit. Said back panel includes a bottom plate and a side wall; said light guide plate is arranged on the bottom plate of the back panel. Said light source is arranged on the side wall of said back panel. Said optical membrane unit is arranged above the light guide plate.

Preferably, said backlight module includes a back panel, a diffusion plate and a light source; said back panel includes a bottom plate and a side wall. Said light source is arranged on the bottom plate of said back panel, and said diffusion plate is arranged on the top part of the side wall of said back panel.

The invention claims a fixed structure for the liquid crystal display device and a liquid crystal display device thereof, which takes three ones out of the four edges of the front frame to integrally mold into the edge frame of the front frame by the plastic cement. The fourth edge is the fixed frame which is made of metal material; meanwhile, the inner side of the edge frame comprises a bulge; the external side of the main-body rubber frame comprises a groove correspondingly matched with the bulge. In the process of assembling, the bulge in the edge frame is inserted into the groove of the main-body rubber frame, and the fixed frame is fixed on the main-body rubber frame by screws; as a result, the invention

simplifies the assembling process for the liquid crystal display module. Additionally, since the edge frame is made of plastic cement so that the weight of the liquid crystal display module is reduced and the cost is saved as well.

DESCRIPTION OF ATTACHED DRAWINGS

FIG. 1 is the front view for the first exemplary embodiment of the liquid display device in the invention.

FIG. 2 is the cutaway view in A-A direction illustrated in FIG. 1.

FIG. 3 is the cutaway view in B-B direction illustrated in FIG. 1.

FIG. 4 is the cutaway view for the second exemplary embodiment of the liquid display device in the invention.

The purpose implementation, the function features and advantages of the invention will be further illustrated by integrating the exemplary embodiments and taking the attached drawings as references.

DETAILED DESCRIPTION OF THE EMBODIMENTS

The technical method for realizing the purpose of the invention will be exactly illustrated according to the attached drawings and the exemplary embodiments. It should be understood that the described detailed exemplary embodiment is only used for illustrating this invention rather than limiting.

Please take the FIG. 1, FIG. 2 and FIG. 3 as references, wherein FIG. 1 is the front view for the first exemplary embodiment of the liquid display device in the invention; FIG. 2 is the cutaway view in A-A direction illustrated in FIG. 1; and FIG. 3 is the cutaway view in B-B direction illustrated in FIG. 1.

In this exemplary embodiment, said liquid crystal display device includes a liquid crystal panel 10, a main-body rubber frame 20, a front frame 30 and a backlight module 40. In this exemplary embodiment, said backlight module 40 is a side-light type backlight module, which includes a back panel 41, a light guide plate 42, a light source 43 and an optical membrane unit 44; said back panel 41 includes a bottom plate 411 and a side wall 412; said light guide plate 42 is arranged on the bottom plate 411 of the back panel 41; and said light source 43 is arranged on the side wall 412 of said back panel 40, moreover, said light source 43 lies on the opposite two sides of said light guide plate 42. Certainly, in this exemplary embodiment, said light source 43 is arranged on the opposite two sides of the light guide plate 42; and in other exemplary embodiments, said light source 43 can only be arranged on one side or three sides or four sides of the light guide plate 42.

Said main-body rubber frame 20 is a square-frame shape; one side of said main-body rubber frame 20 is opened with a first locking hole (not shown in the FIGS); the outer side of said main-body rubber frame 20 is slotted with a groove 21, and the inner side of said main-body rubber frame 20 is internally protruded with a support chip 22. Said support chip 22 of the main-body rubber frame 20 supports the liquid crystal panel 10 thereon; moreover, said liquid crystal panel 10 lies into said main-body rubber frame 20.

Said backlight module 40 is arranged into said main-body rubber frame 20 and lies below said support chip 22. Preferably, the surface of said support chip 22 that lies above the light source 43 is formed with a reflection layer (not shown in the FIGS); said reflection layer is a surface layer formed by the method of two-color molding with the function of reflection or it is a reflection layer plated with metals. The light

5. The fixed structure according to claim 4, wherein said edge frame comprises a side wall; the upper end of said side wall is internally and vertically extended with said first clamping part; the middle part of said side wall is internally and vertically extended with said bulge.

6. The fixed structure according to claim 4, wherein the surface of said support chip that lies above the light source is formed with a reflection layer; said reflection layer is a surface layer formed by the method of two-color molding with the function of reflection or it is a reflection layer plated with metals.

7. A fixed structure for the liquid crystal display device, wherein said liquid crystal display device comprises a liquid crystal panel and a backlight module; said fixed structure comprises a main-body rubber frame and a front frame fixed on the outer side of the main-body rubber frame; said main-body rubber frame comprises a groove and a support chip; said support chip supports the liquid crystal panel thereon; said backlight module is arranged into the main-body rubber frame and lies below the support chip; said front frame comprises an edge frame and a fixed frame; said edge frame comprises a first clamping part and a bulge matched with said groove; said fixed frame comprises a second clamping part; said first clamping part and said second clamping part as well as said support chip are used for clamping and fixing said liquid crystal panel;

said fixed frame further comprises a fixed edge frame and two joint frames that are arranged on the two ends of the fixed edge frame and are vertical to the fixed edge frame, both said fixed edge frame and said joint frame internally form the second clamping part;

said main-body rubber frame is opened with first locking holes; the two ends of said edge frame are opened with second locking holes; said fixed edge frame is opened with third locking holes, and said joint frames are opened with fourth locking holes; multiple screws penetrate through said third locking holes and said first locking holes to fix said fixed frame on the main-body rubber frame; moreover, multiple screws penetrate through said fourth locking holes, said second locking holes and said first locking holes to simultaneously fix said edge frame and said fixed frame on said main-body rubber frame.

8. The fixed structure according to claim 7, wherein said main-body rubber frame is a square frame shape; said groove is arranged on the outer side of said main-body rubber frame; said support chip is arranged on the inner side of said main-body rubber frame and is internally protruded.

9. The fixed structure according to claim 7, wherein said edge frame is arranged on the outer side of said main-body rubber frame in order to encircle the three sides of said main-body rubber frame; and the bulge of said edge frame is clamped into the groove of said main-body rubber frame.

10. The fixed structure according to claim 7, wherein said edge frame is integrally molded by the plastic cement; and such edge frame is integrally n-shaped.

11. The fixed structure according to claim 10, wherein said edge frame comprises a side wall; the upper end of said side wall is internally and vertically extended with said first clamping part; the middle part of said side wall is internally and vertically extended with said bulge.

12. The fixed structure according to claim 7, wherein the surface of said support chip that lies above the light source is formed with a reflection layer; said reflection layer is a surface layer formed by the method of two-color molding with the function of reflection or it is a reflection layer plated with metals.

13. The fixed structure according to claim 7, wherein said backlight module comprises a back panel, a light guide plate, a light source and an optical membrane unit; said back panel comprises a bottom plate and a side wall; said light guide plate is arranged on the bottom plate of the back panel; said light source is arranged on the side wall of said back panel; said optical membrane unit is arranged above the light guide plate.

14. The fixed structure according to claim 13, wherein said light source lies on the opposite two sides of said light guide plate.

15. The fixed structure according to claim 7, wherein said backlight module comprises a back panel, a diffusion plate and a light source; said back panel comprises a bottom plate and a side wall; said light source is arranged on the bottom plate of said back panel; and said diffusion plate is arranged on the top part of the side wall of said back panel.

16. A liquid crystal display device, wherein said liquid crystal display device comprises a fixed structure, a liquid crystal panel and a backlight module; said liquid crystal panel is clamped into said fixed structure; said backlight module is arranged into said fixed structure and lies below said liquid crystal panel; said fixed structure comprises a main-body rubber frame and a front frame fixed on the outer side of the main-body rubber frame; said main-body rubber frame comprises a groove and a support chip; said support chip supports the liquid crystal panel thereon; said backlight module is arranged into said main-body rubber frame and lies below the support chip; said front frame comprises an edge frame and a fixed frame; said edge frame comprises a first clamping part and a bulge matched with said groove; said fixed frame comprises a second clamping part; said first clamping part and said second clamping part as well as said support chip are used for clamping and fixing said liquid crystal panel;

said fixed frame further comprises a fixed edge frame and two joint frames that are arranged on the two ends of the fixed edge frame and are vertical to the fixed edge frame, both said fixed edge frame and said joint frame internally form the second clamping part;

said main-body rubber frame is opened with first locking holes; said main-body rubber frame is opened with first locking holes; the two ends of said edge frame are opened with second locking holes; said fixed edge frame is opened with third locking holes, and said joint frames are opened with fourth locking holes; multiple screws penetrate through said third locking holes and said first locking holes to fix said fixed frame on the main-body rubber frame; moreover, multiple screws penetrate through said fourth locking holes, said second locking holes and said first locking holes to simultaneously fix said edge frame and said fixed frame on said main-body rubber frame.

17. The liquid crystal display device according to claim 16, wherein said backlight module comprises a back panel, a light guide plate, a light source and an optical membrane unit; said back panel comprises a bottom plate and a side wall; said light guide plate is arranged on the bottom plate of the back panel; said light source is arranged on the side wall of said back panel; said optical membrane unit is arranged above the light guide plate.

18. The fixed structure according to claim 16, wherein said backlight module comprises a back panel, a diffusion plate and a light source; said back panel comprises a bottom plate and a side wall; said light source is arranged on the bottom

plate of said back panel; and said diffusion plate is arranged on the top part of the side wall of said back panel.

* * * * *

专利名称(译)	液晶显示装置的固定结构及其液晶显示装置		
公开(公告)号	US8558963	公开(公告)日	2013-10-15
申请号	US13/148410	申请日	2011-06-10
[标]申请(专利权)人(译)	李泉		
申请(专利权)人(译)	李铨		
当前申请(专利权)人(译)	深圳市中国星光电科技有限公司.		
[标]发明人	LI QUAN		
发明人	LI, QUAN		
IPC分类号	G02F1/1333 G02F1/1335		
CPC分类号	G02F1/133308 G02F2001/133317 G02F2001/13332 G02F1/1336 G02F2001/133325 G02F2201/46 G02F2201/465 G02F2001/133322		
审查员(译)	WON , BUMSUK		
助理审查员(译)	常 , CHARLES		
优先权	201120126823.0 2011-04-26 CN		
其他公开文献	US20130208208A1		
外部链接	Espacenet USPTO		

摘要(译)

本发明涉及一种用于液晶显示装置的固定结构及其液晶显示装置。所述液晶显示装置包括液晶面板和背光模块。所述固定结构包括主体橡胶框架和固定在主体橡胶框架外侧的前框架。所述主体橡胶框架包括凹槽和支撑芯片。所述支撑芯片支撑其上的液晶面板。所述背光模块设置在主体橡胶框架中并位于支撑芯片下方。所述前框架包括边框和固定框架。所述边框包括第一夹持部和与所述凹槽配合的凸起。所述固定框架包括第二夹紧部分。所述第一夹持部分和所述第二夹持部分以及所述支撑芯片用于夹持和固定所述液晶面板。在组装本发明时，只需将前框架边框的凸起插入主体橡胶框架的凹槽中，然后用螺钉将固定框架固定在主体橡胶框架上；结果，它简化了液晶显示模块的组装过程。另外，由于边缘框架由塑料水泥制成，因此液晶显示模块的重量减小。

