



US 20170248826A1

(19) **United States**

(12) **Patent Application Publication**
CHANG et al.

(10) **Pub. No.: US 2017/0248826 A1**

(43) **Pub. Date: Aug. 31, 2017**

(54) **LIQUID CRYSTAL DISPLAY COMPRISING A PIXEL ELECTRODE HAVING A TRANSVERSE STEM, A LONGITUDINAL STEM, AND A PLURALITY OF MINUTE BRANCHES**

(71) Applicant: **Samsung Display Co., Ltd.**, Yongin-si (KR)

(72) Inventors: **Hak Sun CHANG**, Yongin-si (KR); **Jang Wi RYU**, Seoul (KR); **Ki Chul SHIN**, Suwon-si (KR); **Jae-Soo JANG**, Suwon-si (KR)

(21) Appl. No.: **15/592,578**

(22) Filed: **May 11, 2017**

Related U.S. Application Data

(60) Continuation of application No. 15/144,280, filed on May 2, 2016, now Pat. No. 9,651,834, which is a continuation of application No. 14/931,312, filed on Nov. 3, 2015, now Pat. No. 9,329,442, which is a division of application No. 13/835,941, filed on Mar. 15, 2013, now Pat. No. 9,213,209.

(30) **Foreign Application Priority Data**

Aug. 7, 2012 (KR) 10-2012-0086332

Publication Classification

(51) **Int. Cl.**

G02F 1/1343 (2006.01)

G02F 1/1362 (2006.01)

G02F 1/1337 (2006.01)

(52) **U.S. Cl.**

CPC .. **G02F 1/134309** (2013.01); **G02F 1/133753** (2013.01); **G02F 1/136286** (2013.01); **G02F 2001/133742** (2013.01); **G02F 2001/133757** (2013.01); **G02F 2001/134345** (2013.01); **G02F 2201/121** (2013.01); **G02F 2201/123** (2013.01)

(57)

ABSTRACT

A liquid crystal display, including a first substrate; a gate line and a data line disposed on the first substrate; and a pixel electrode connected to the gate line and the data line and comprising a first sub pixel electrode and a second sub pixel electrode disposed on the first substrate. Each of the first sub pixel electrode and the second sub pixel electrode includes a transverse stem; a longitudinal stem; and a plurality of minute branches extending from transverse stem and the longitudinal stem. A width of the first sub pixel electrode is different from a width of the second sub pixel electrode.

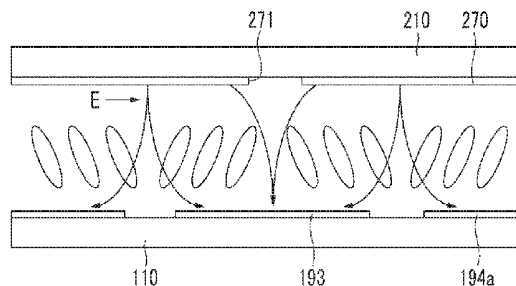
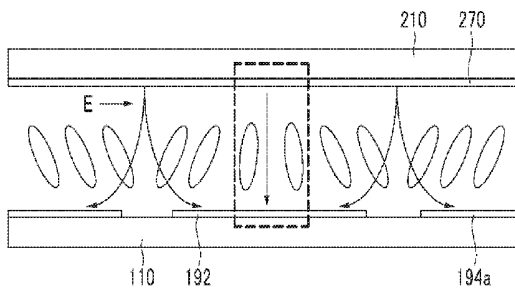

FIG. 1

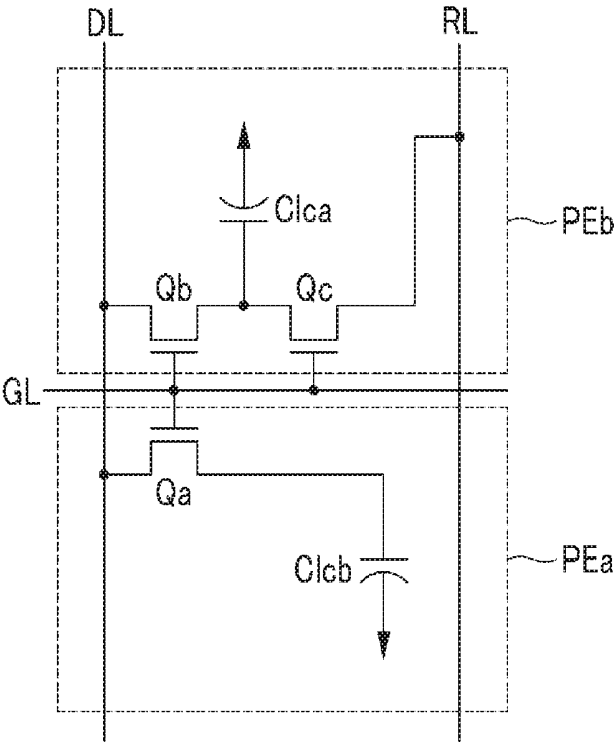

FIG. 2

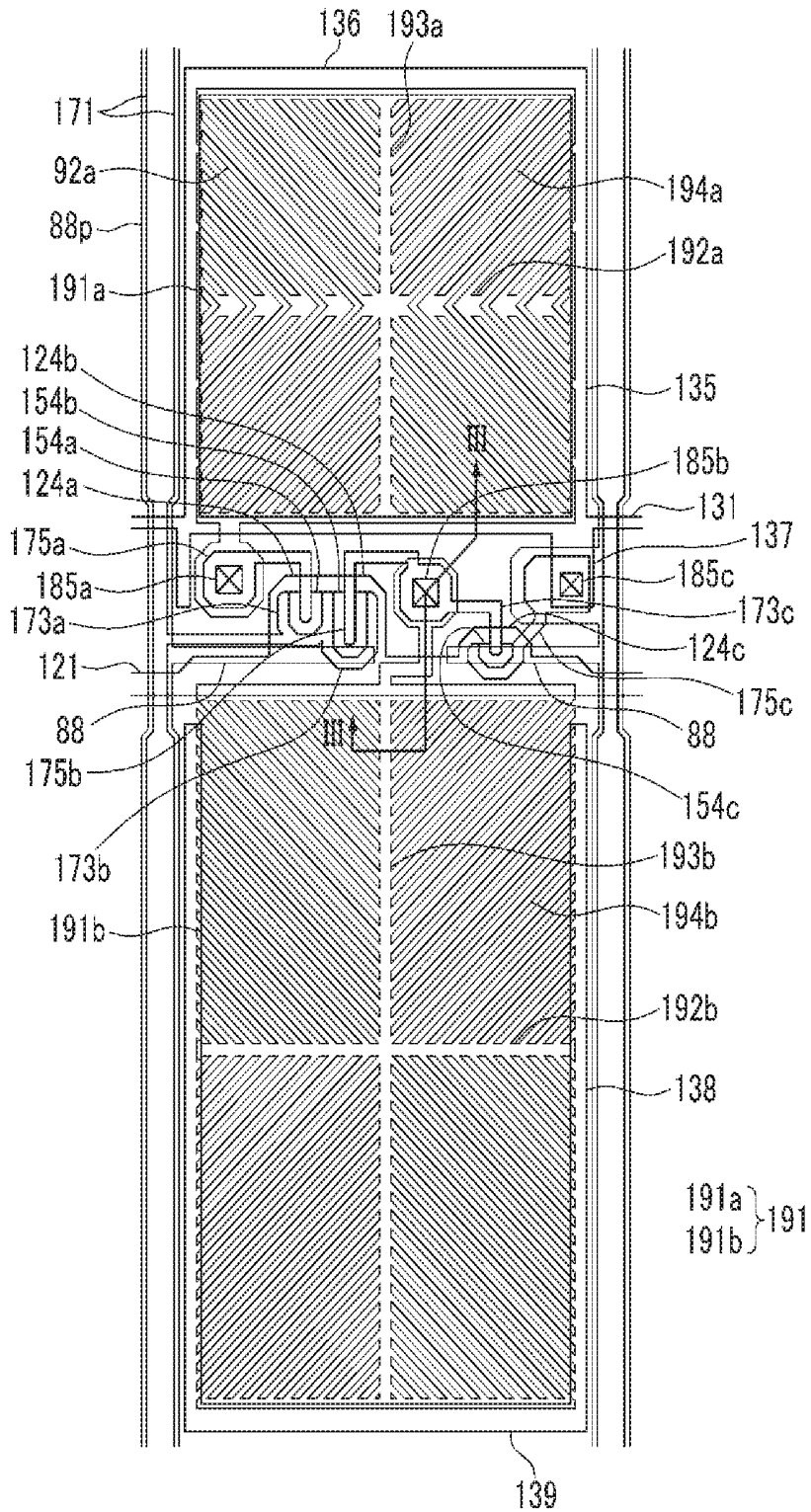

FIG. 3

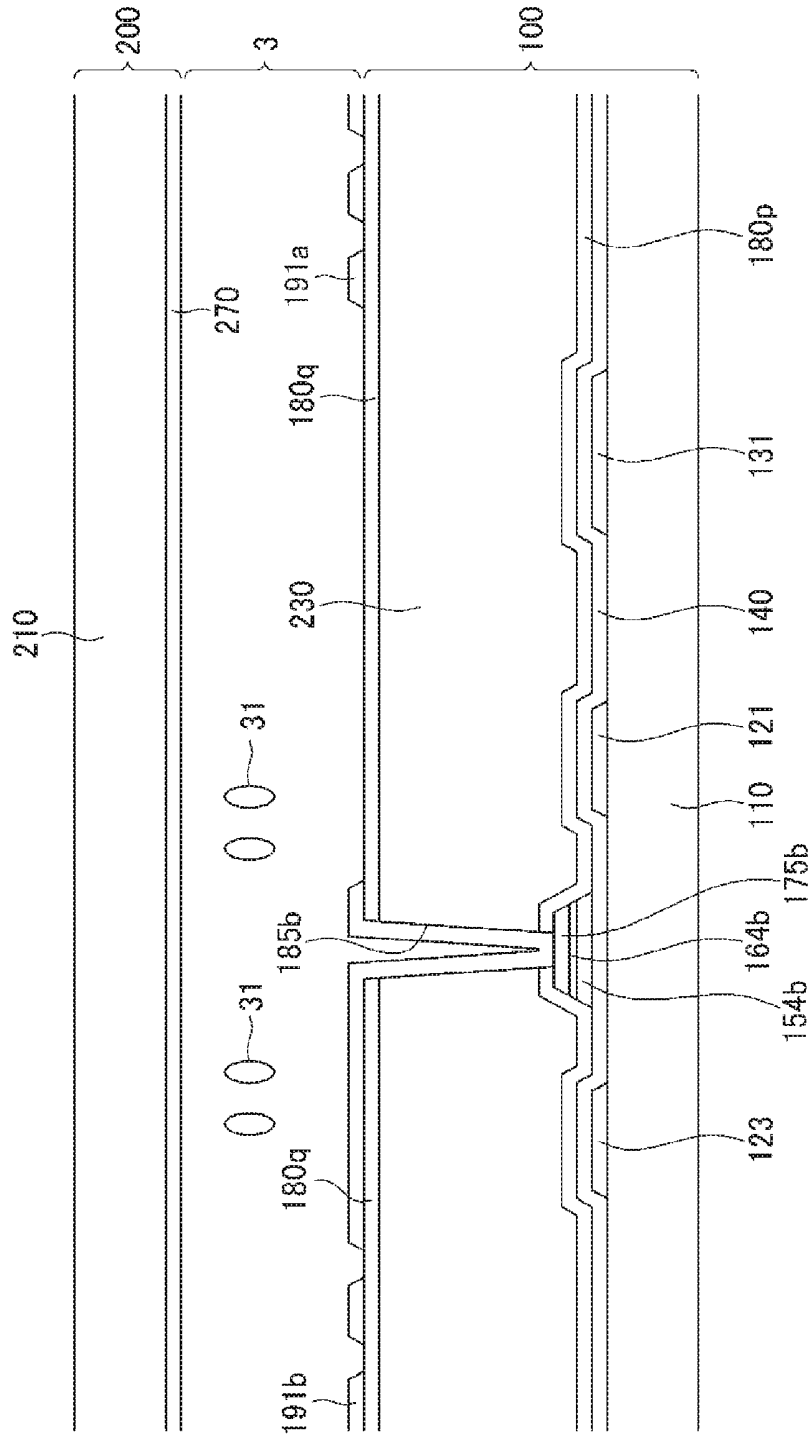

FIG.4

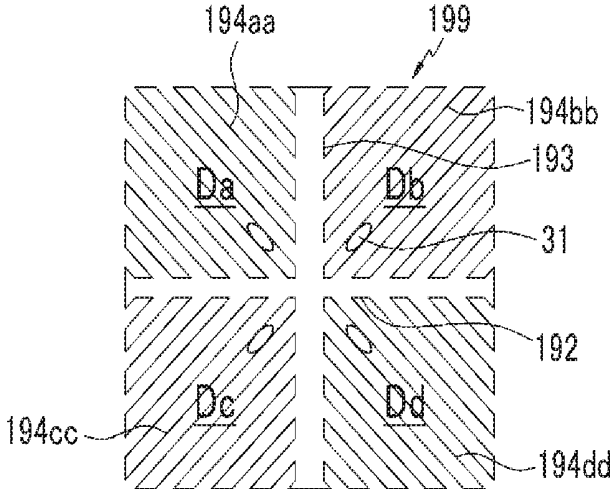

FIG. 5

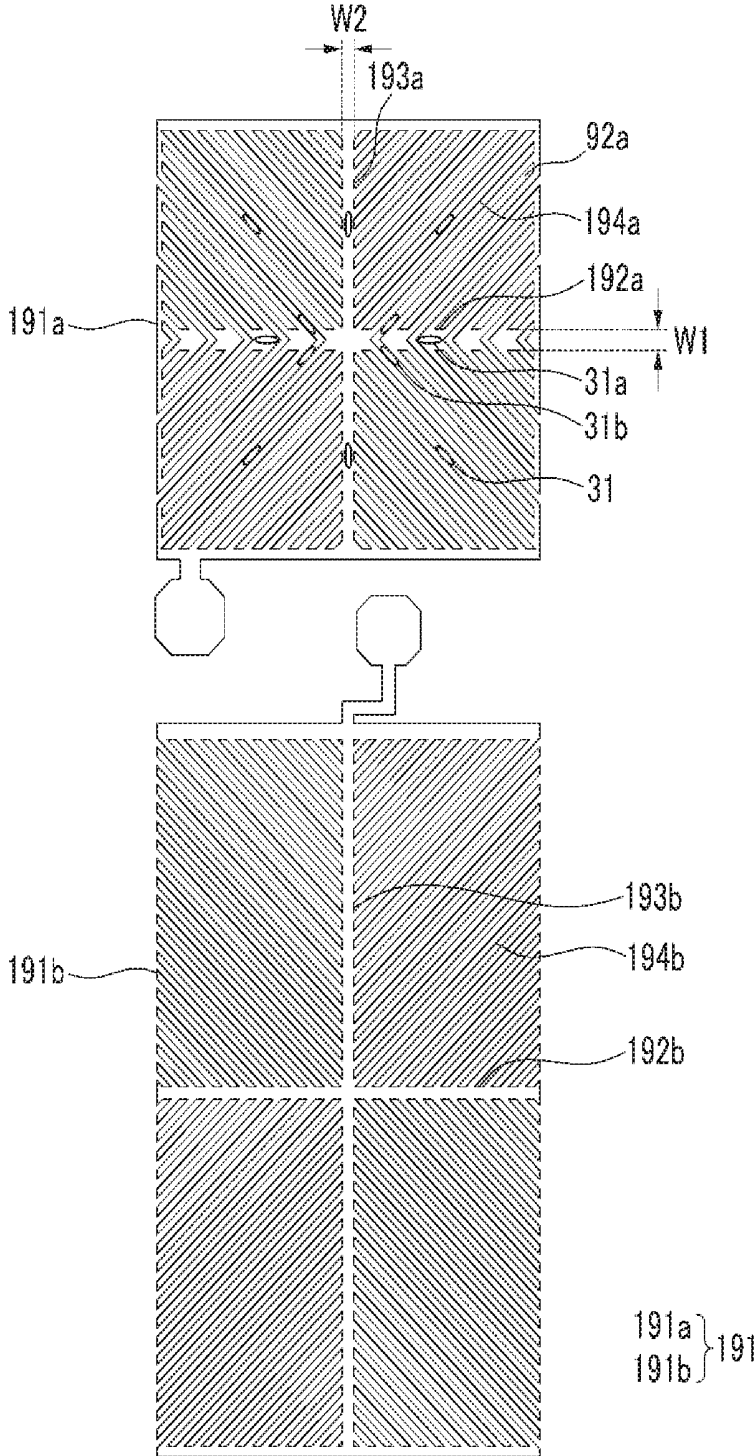

FIG. 6

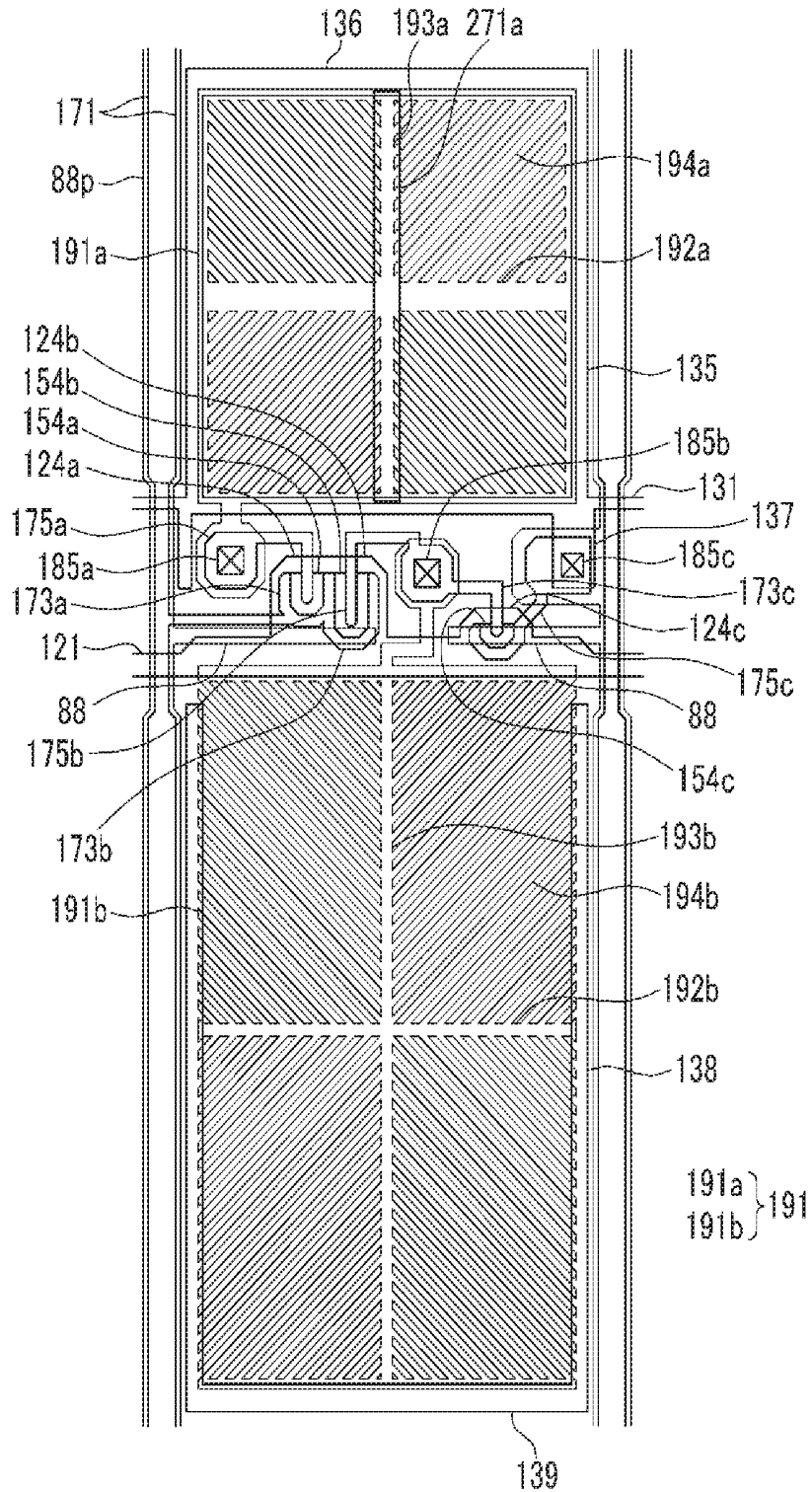

FIG. 7

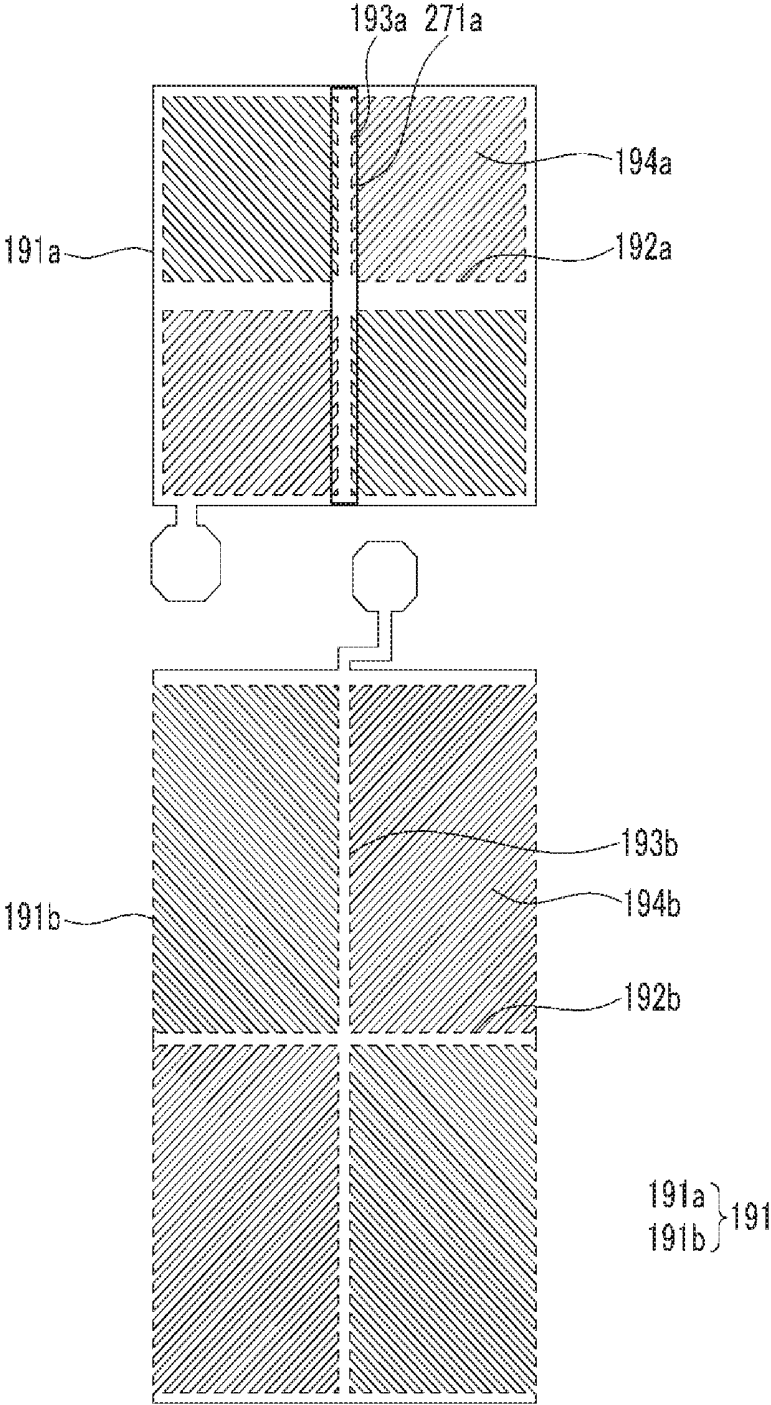

FIG. 8

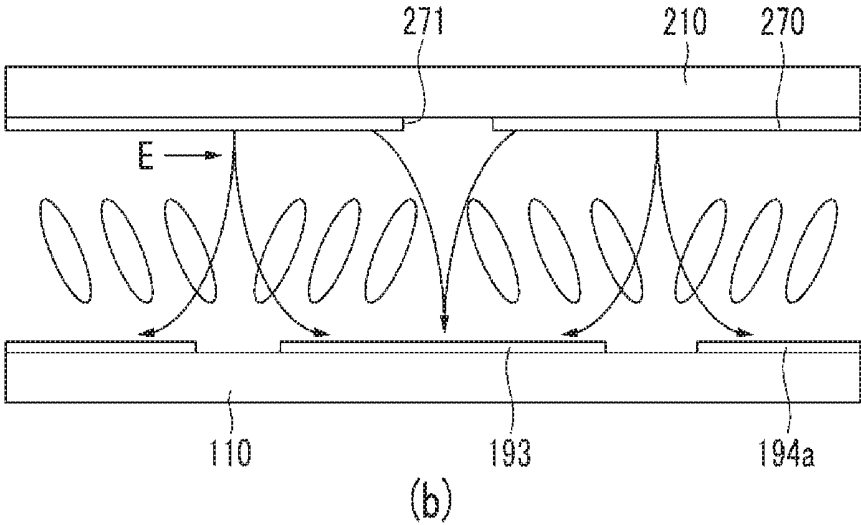
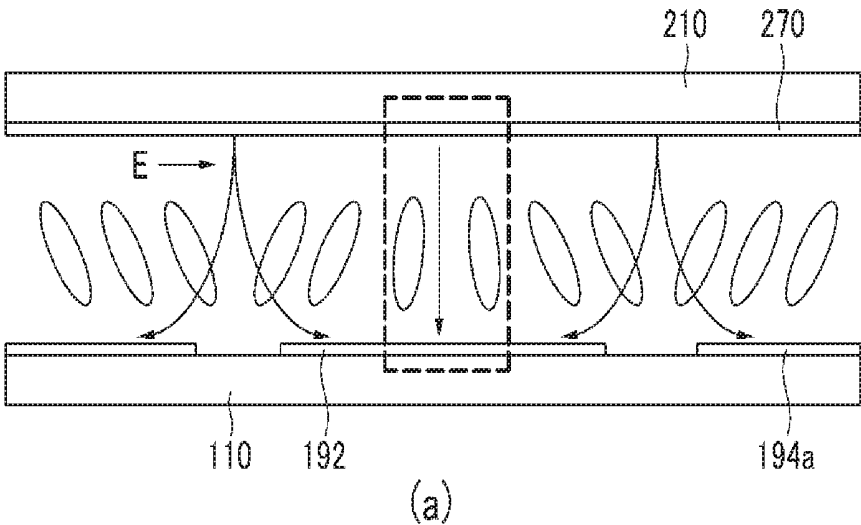

FIG. 9

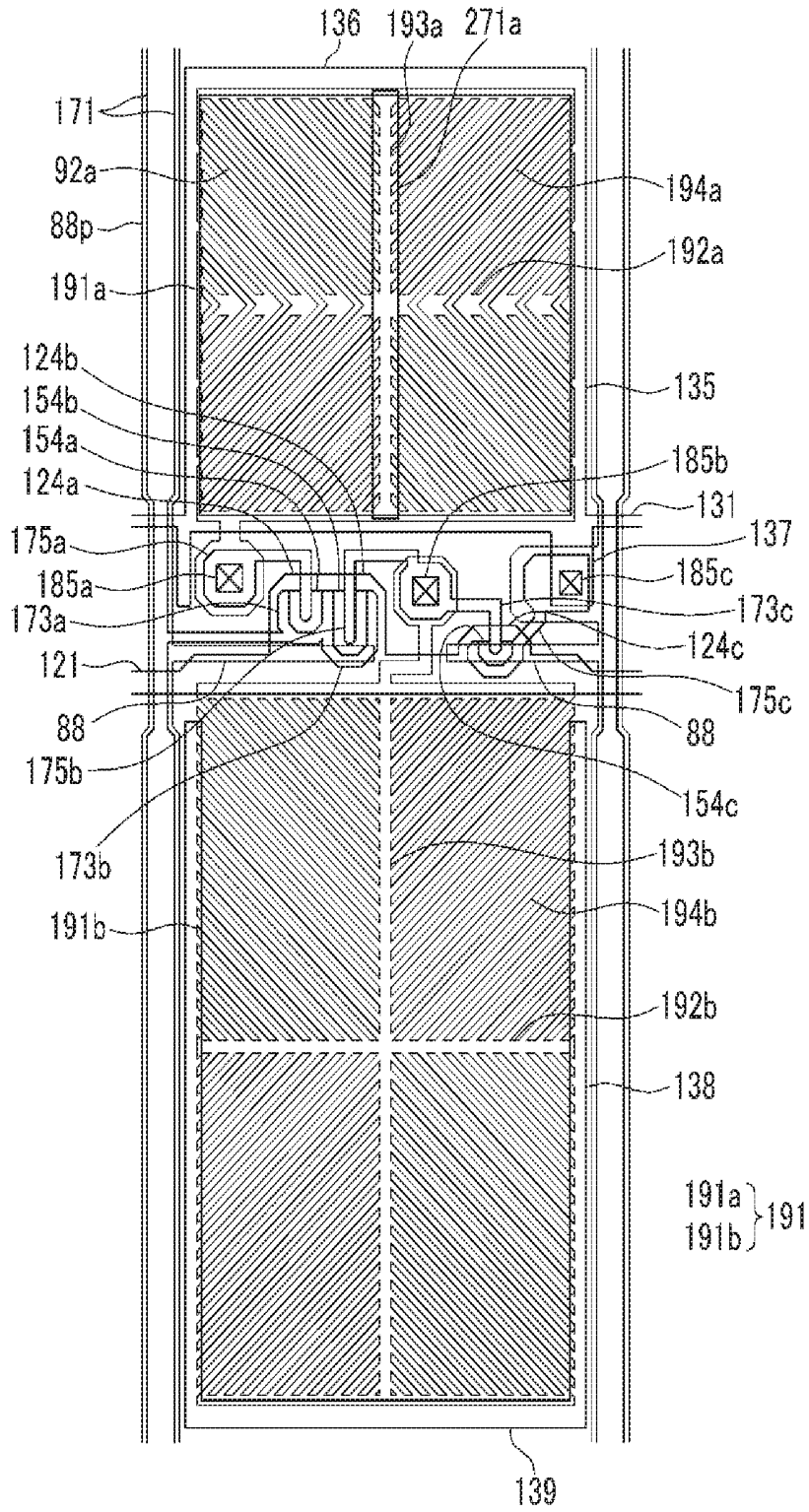

FIG. 10

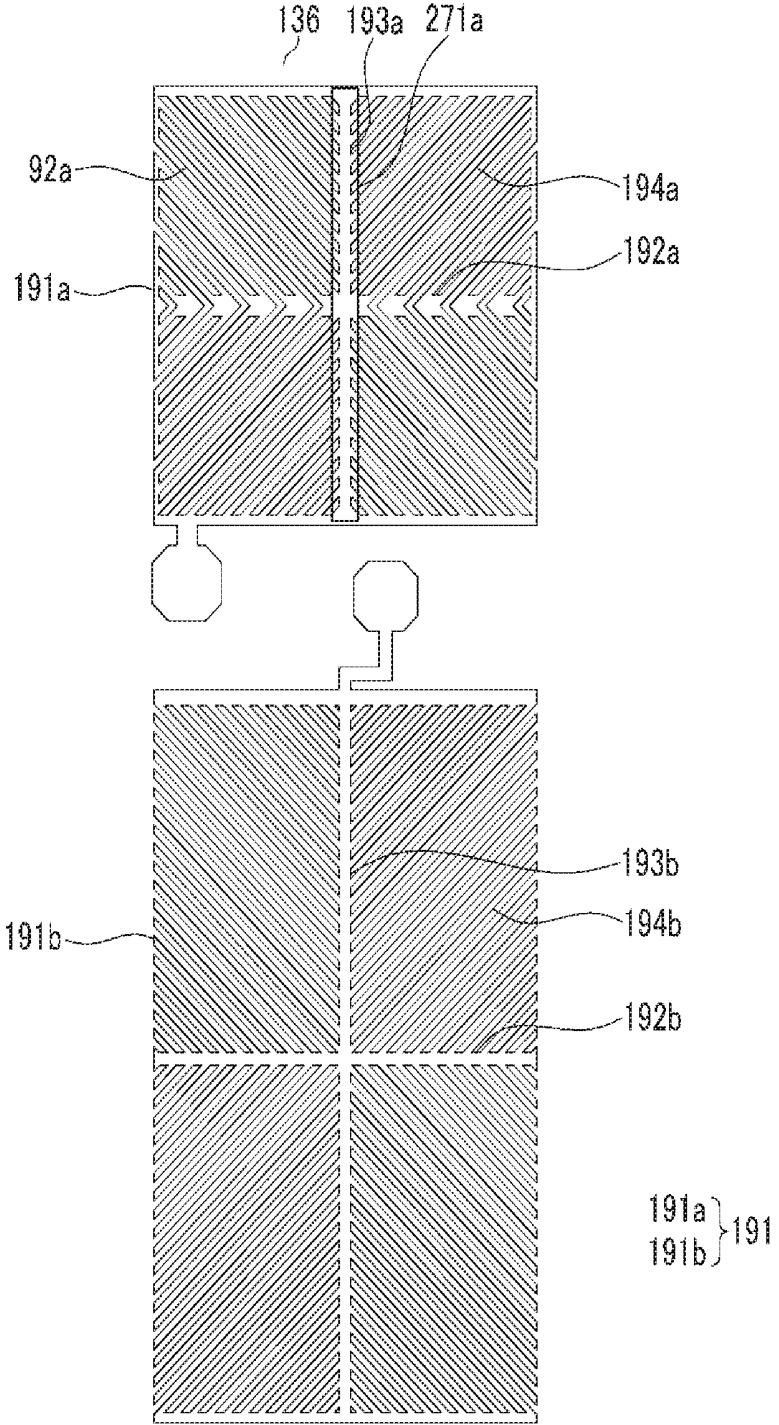

FIG. 11

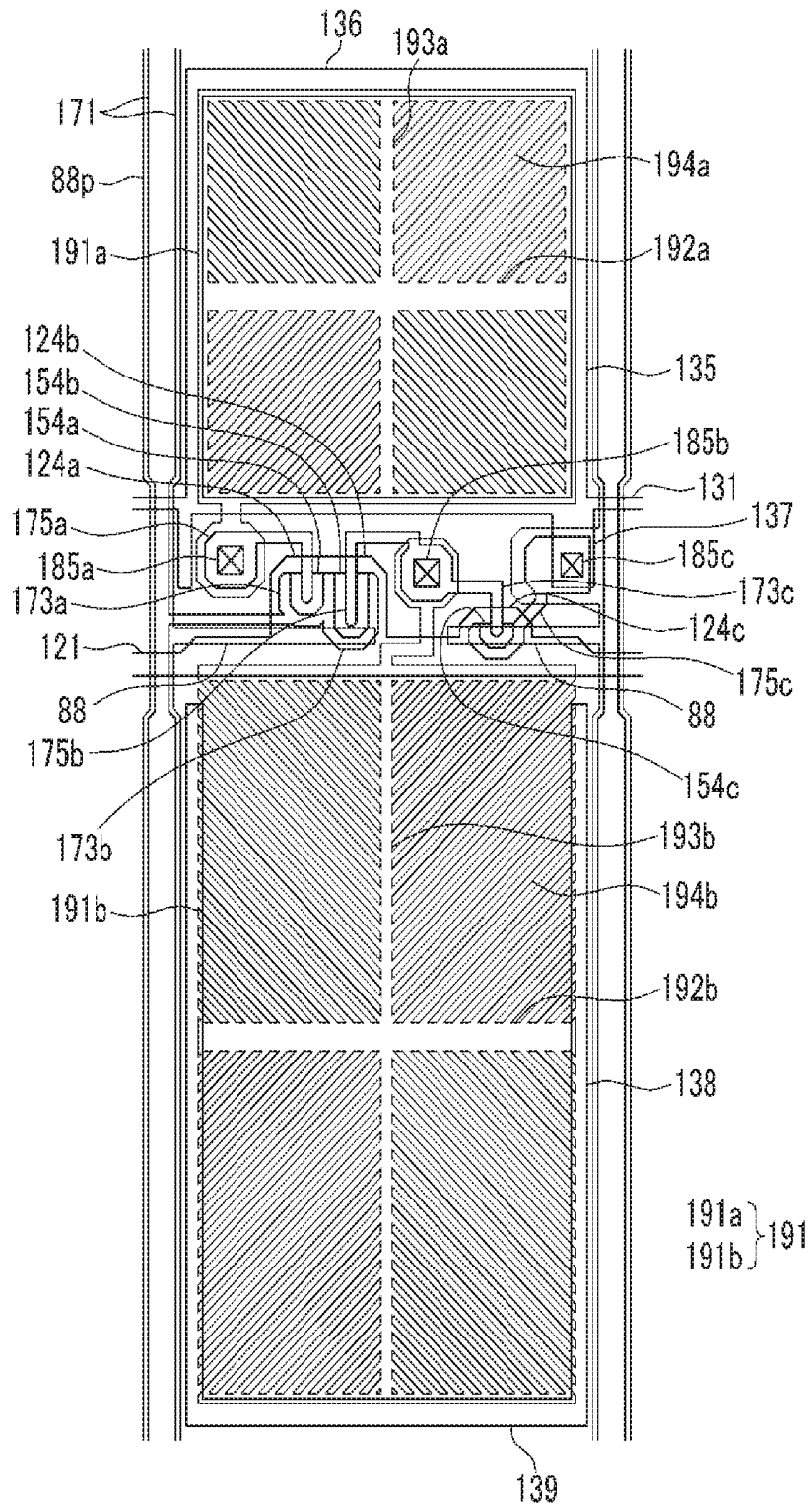

FIG.12

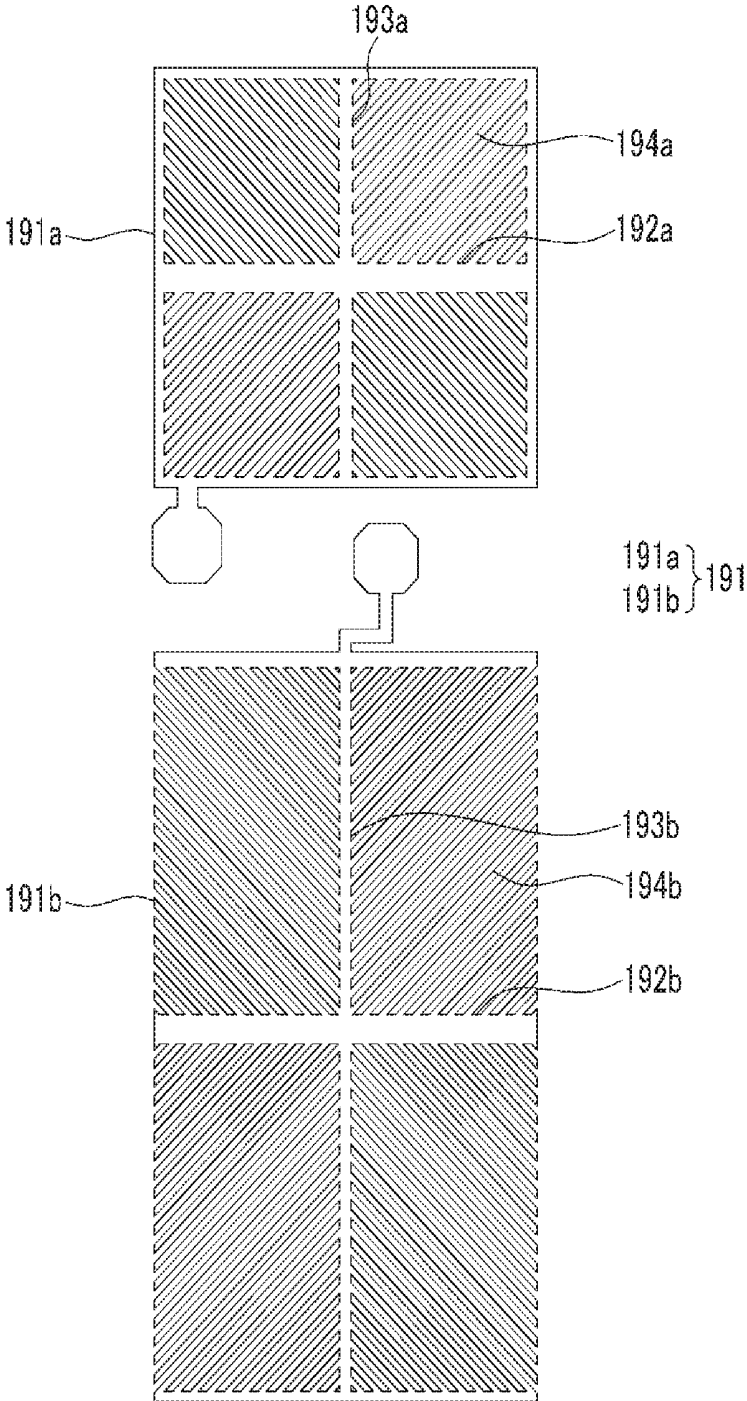

FIG. 14

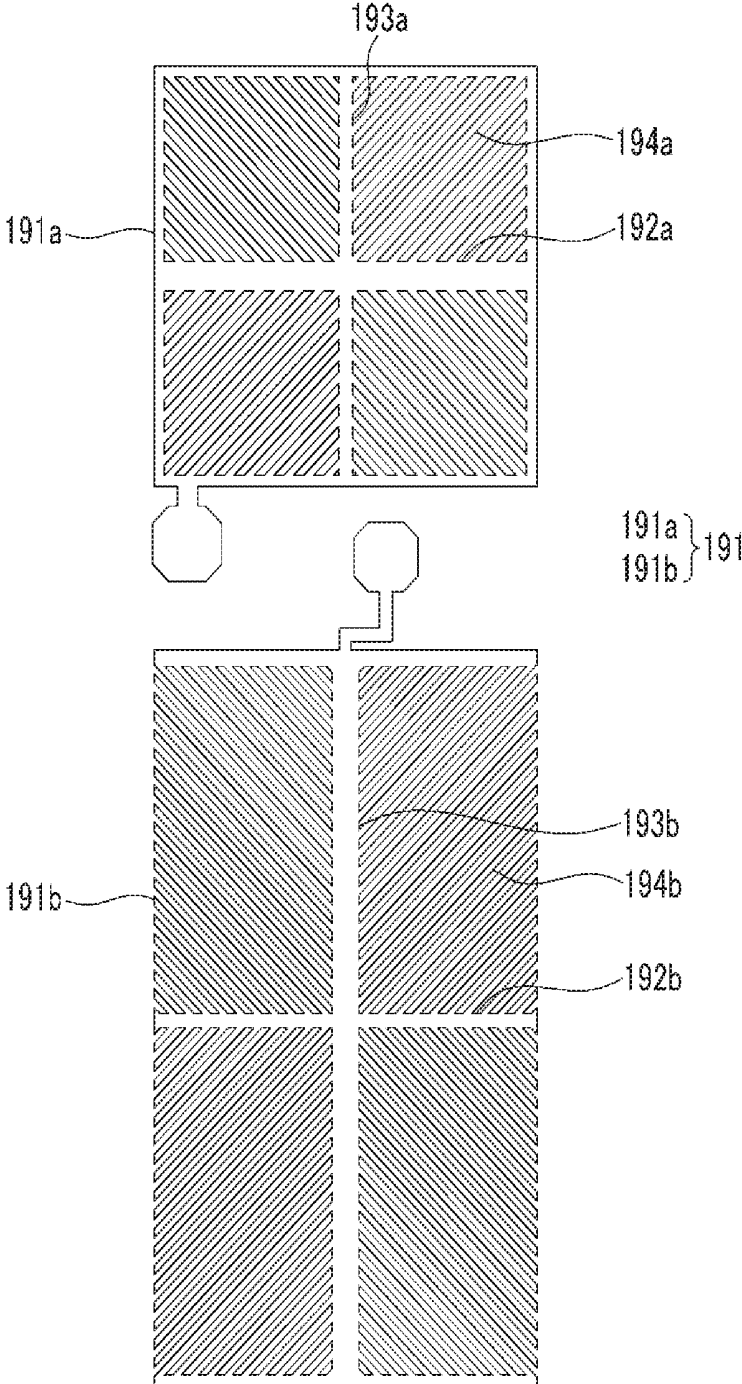

FIG. 15

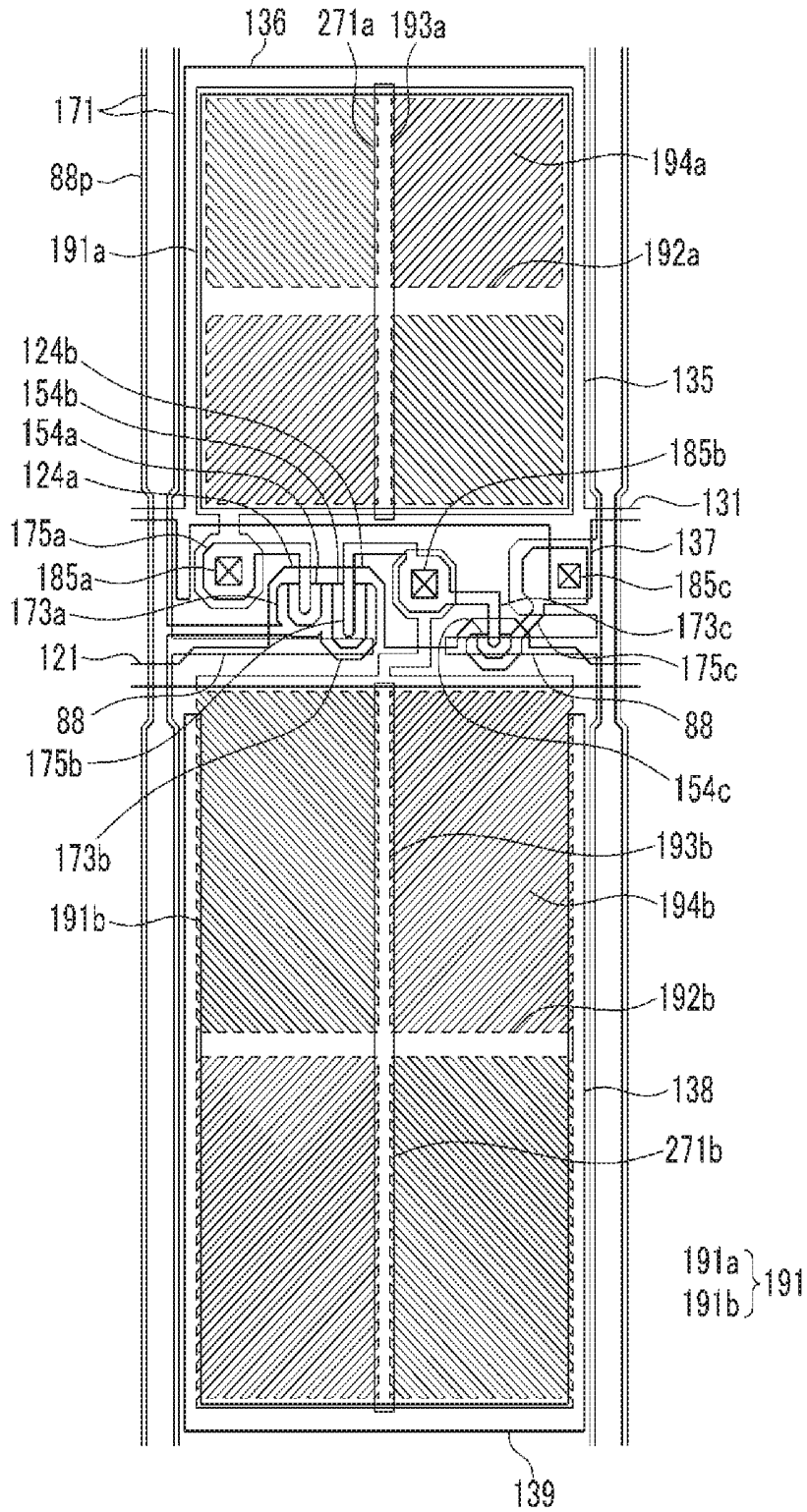

FIG. 16

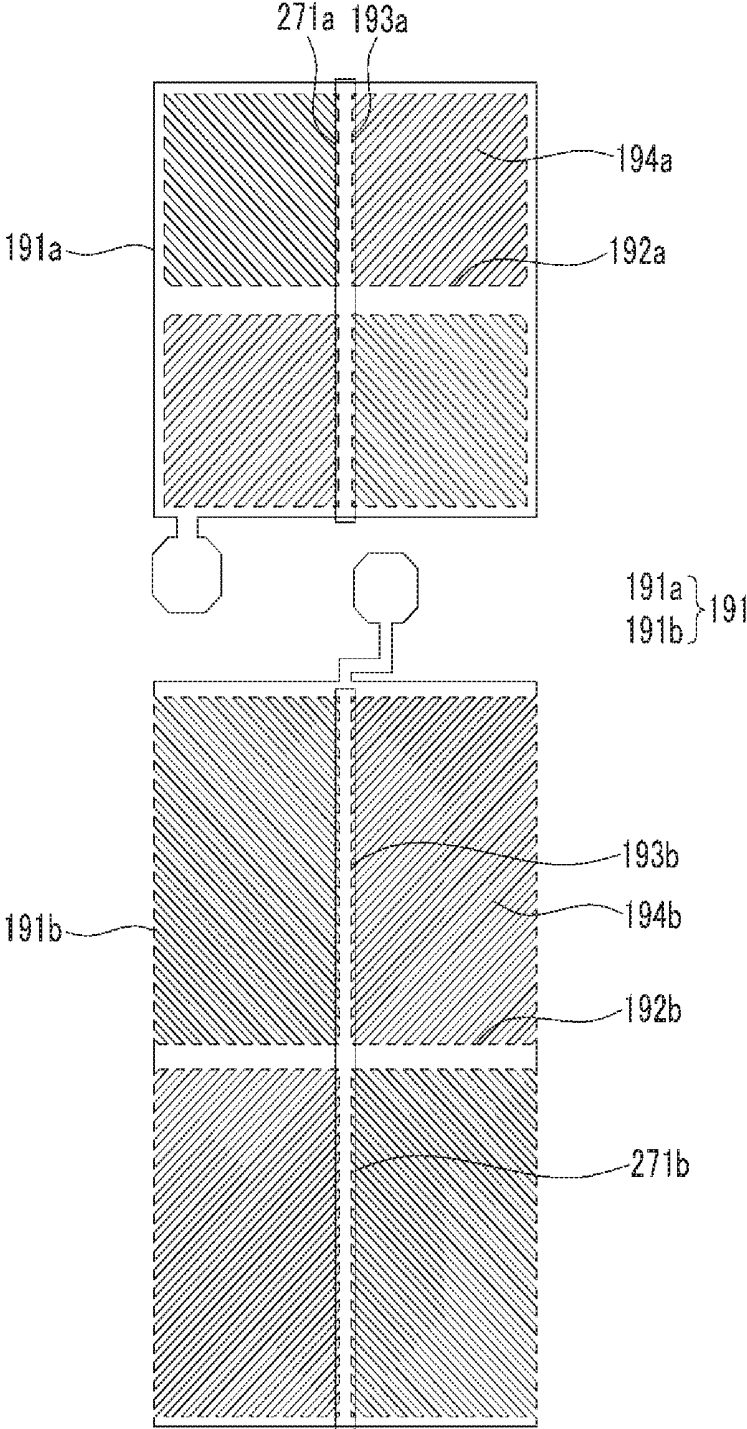

FIG. 17

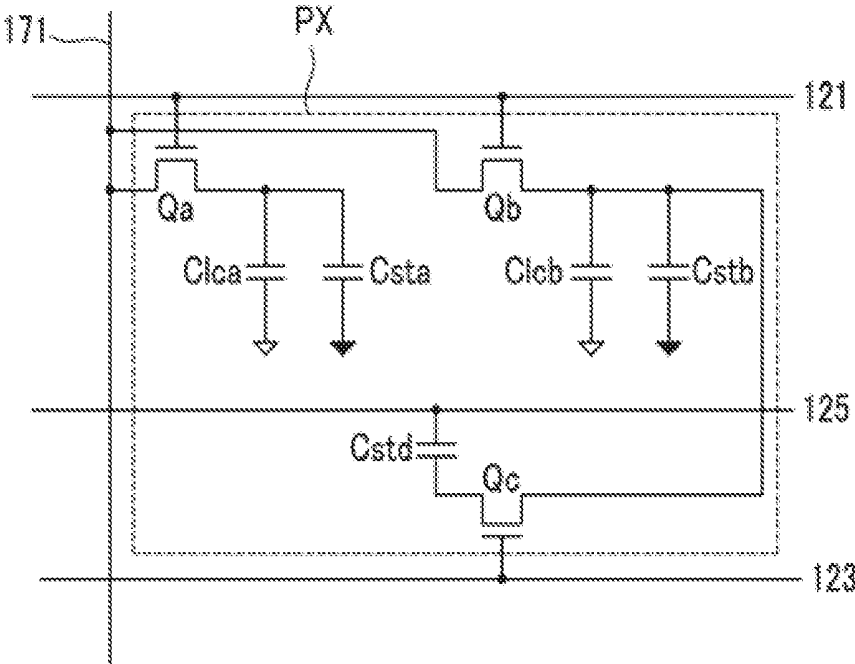

FIG. 18

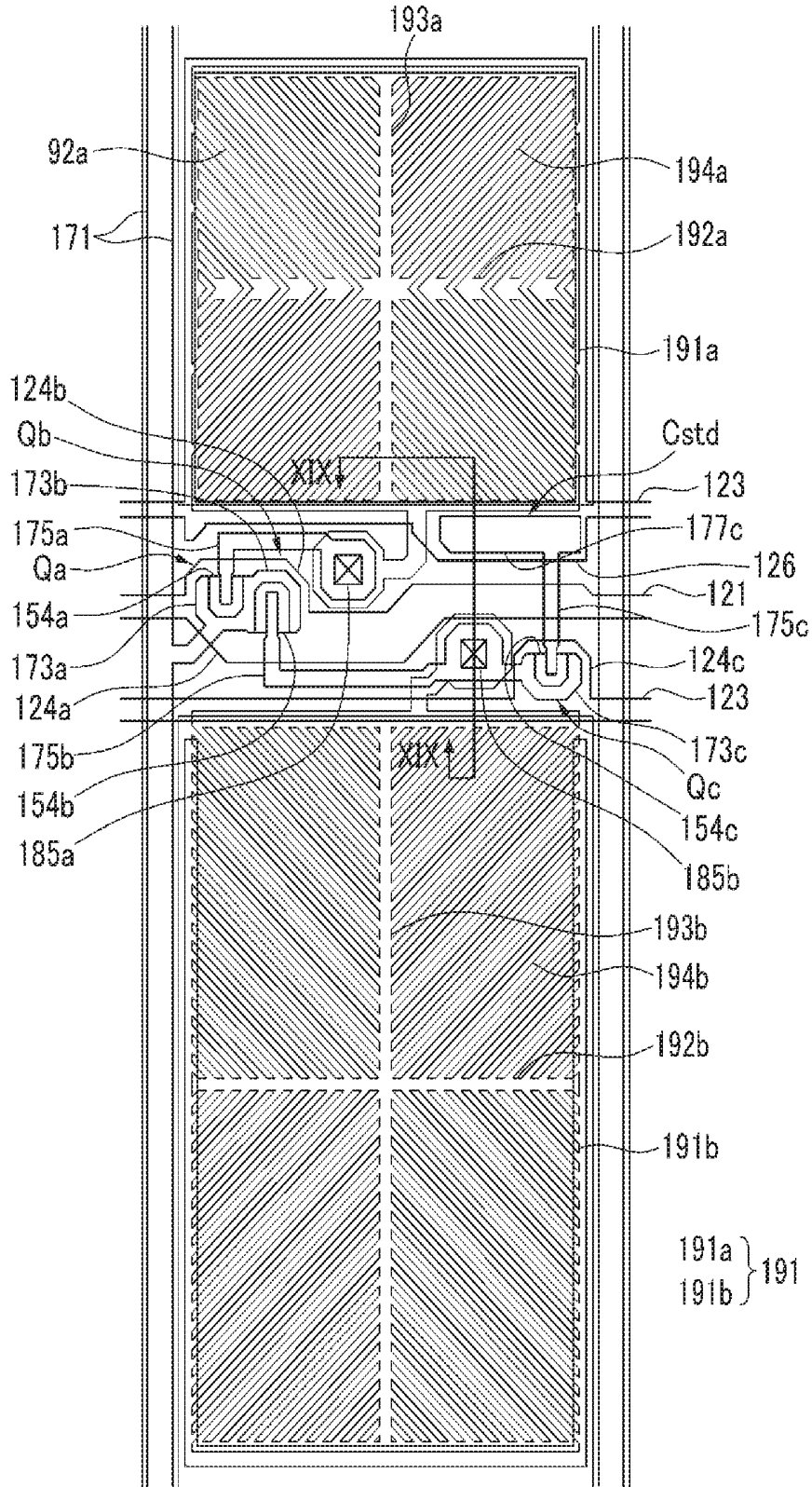

FIG. 19

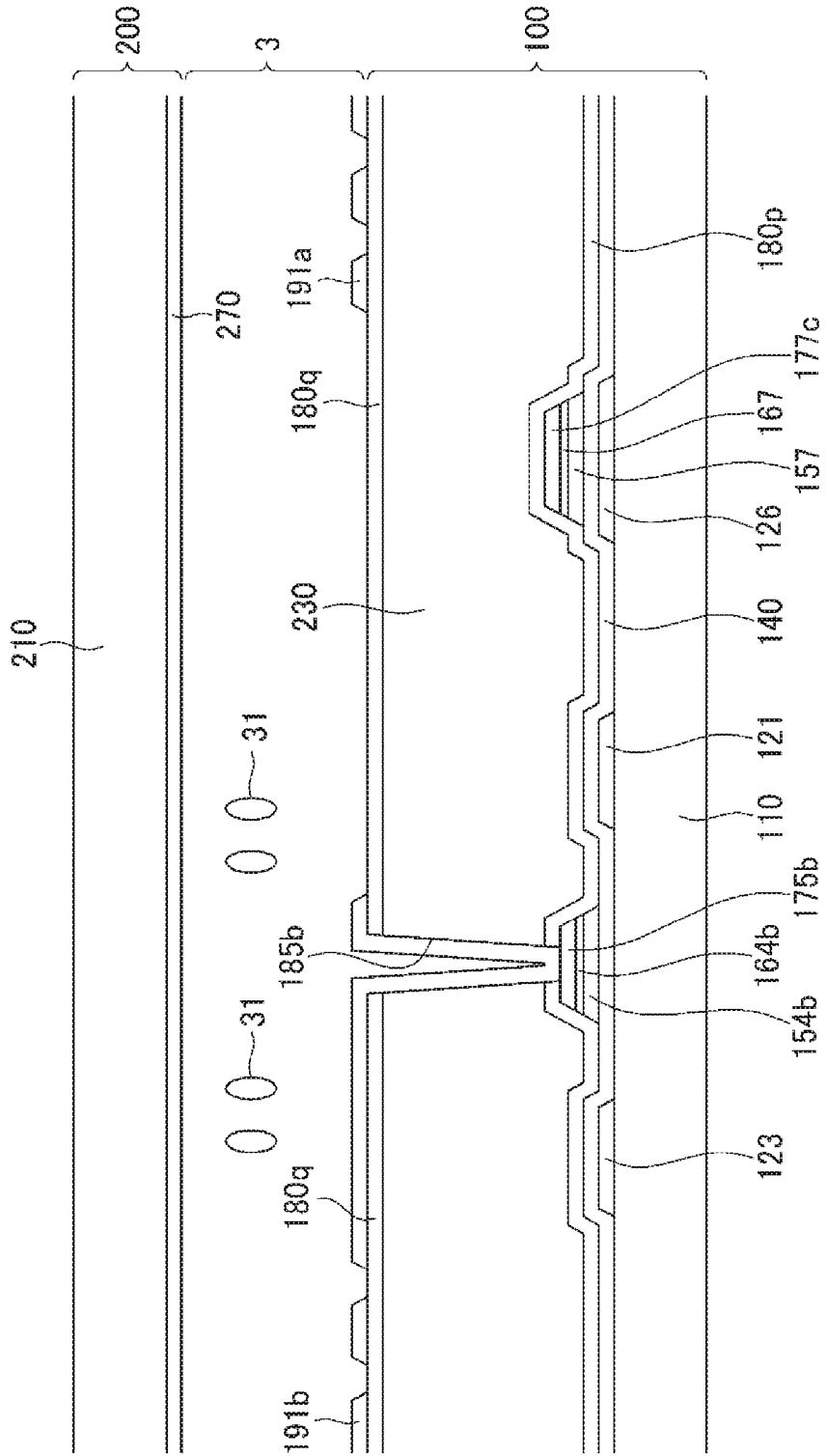

FIG. 20

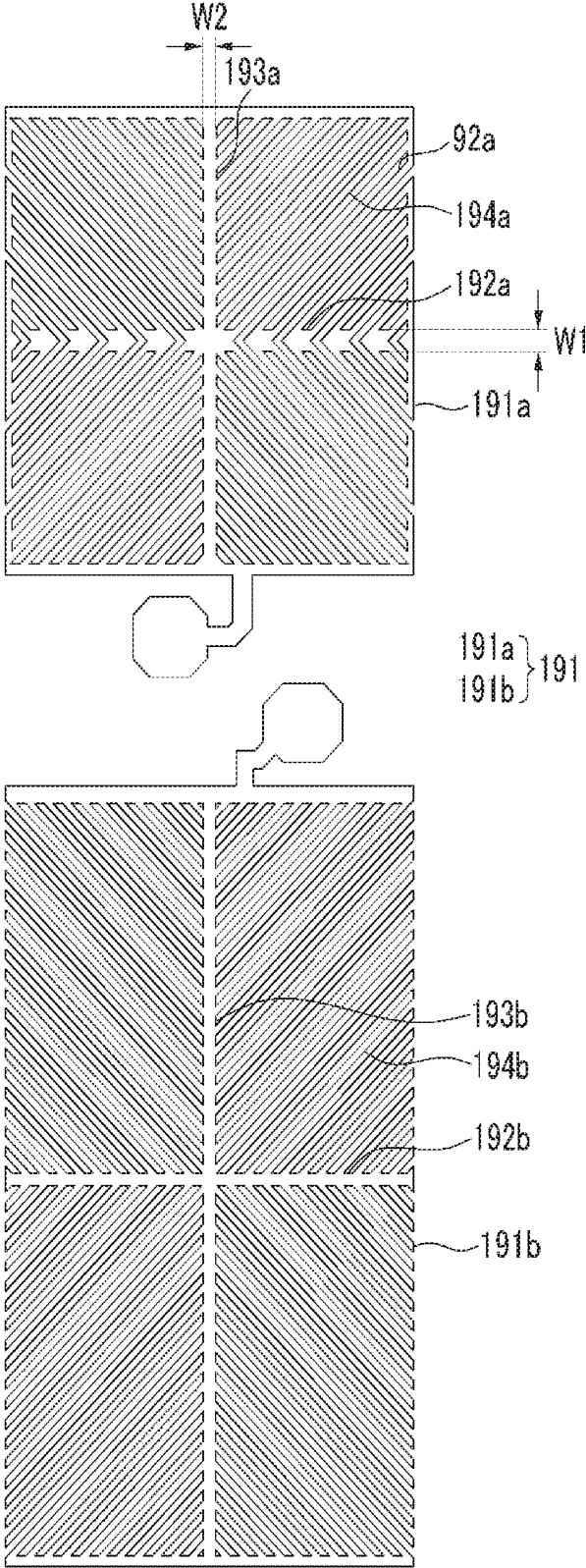

FIG. 21

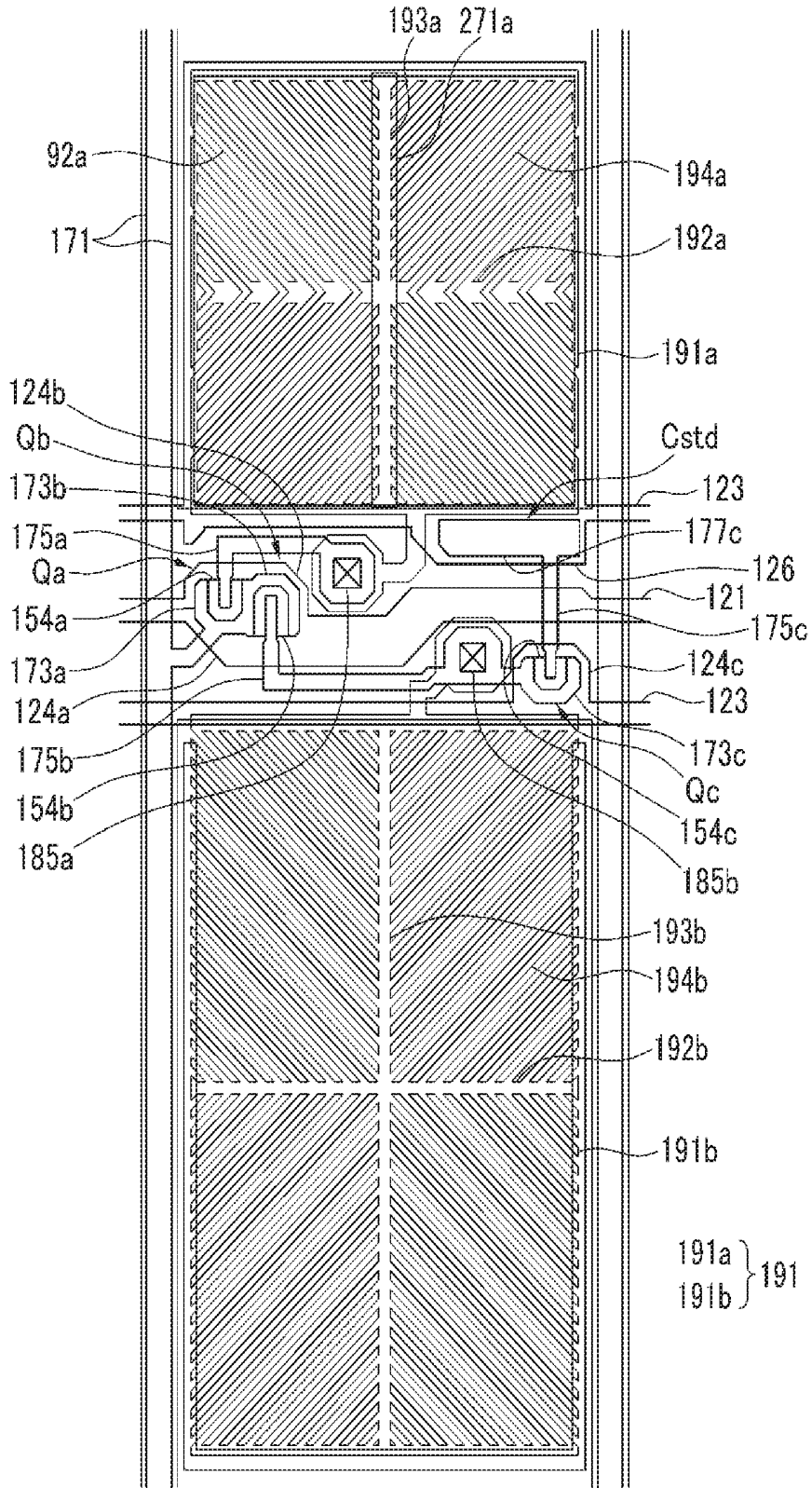

FIG.22

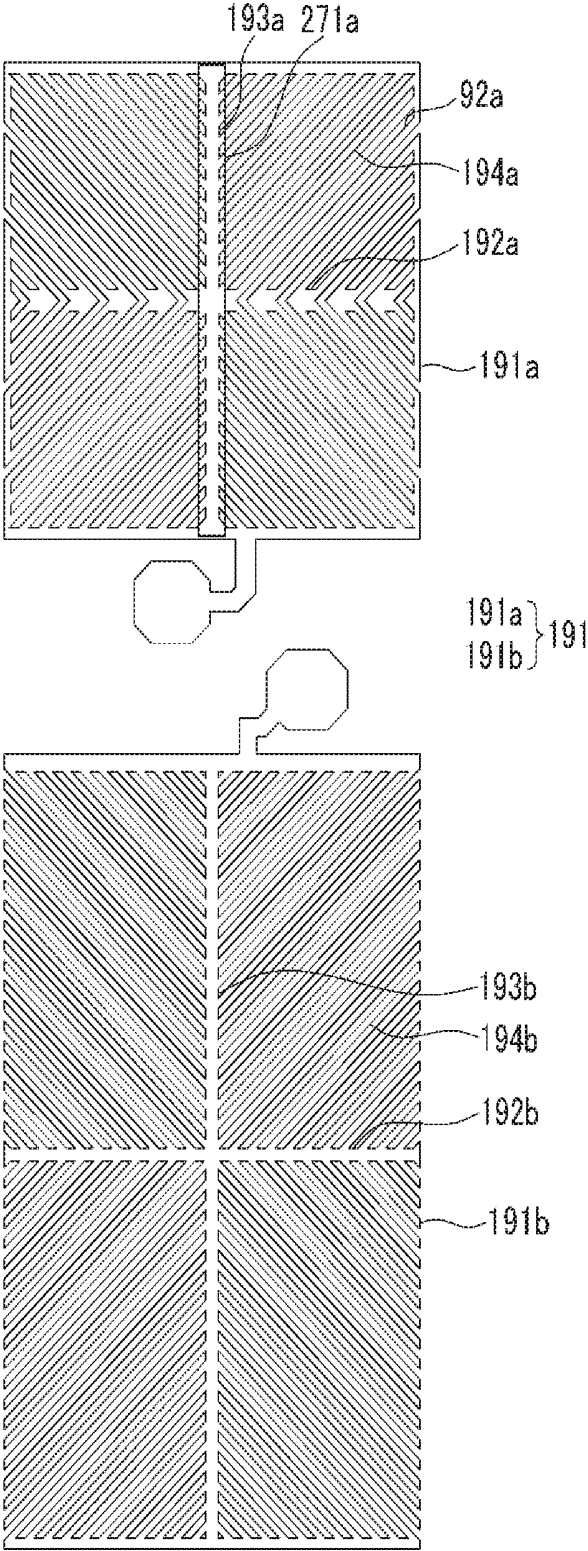

FIG. 23

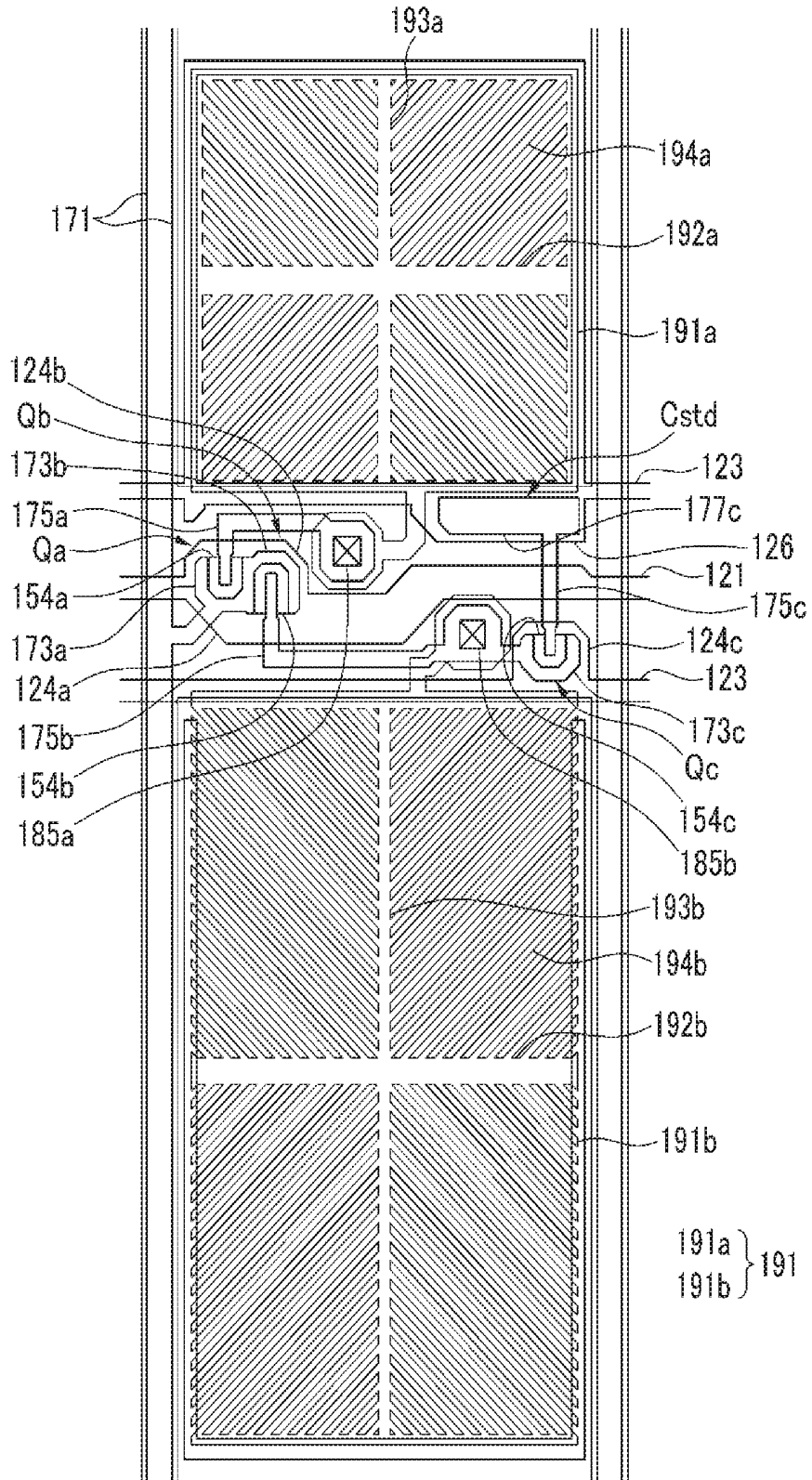

FIG. 24

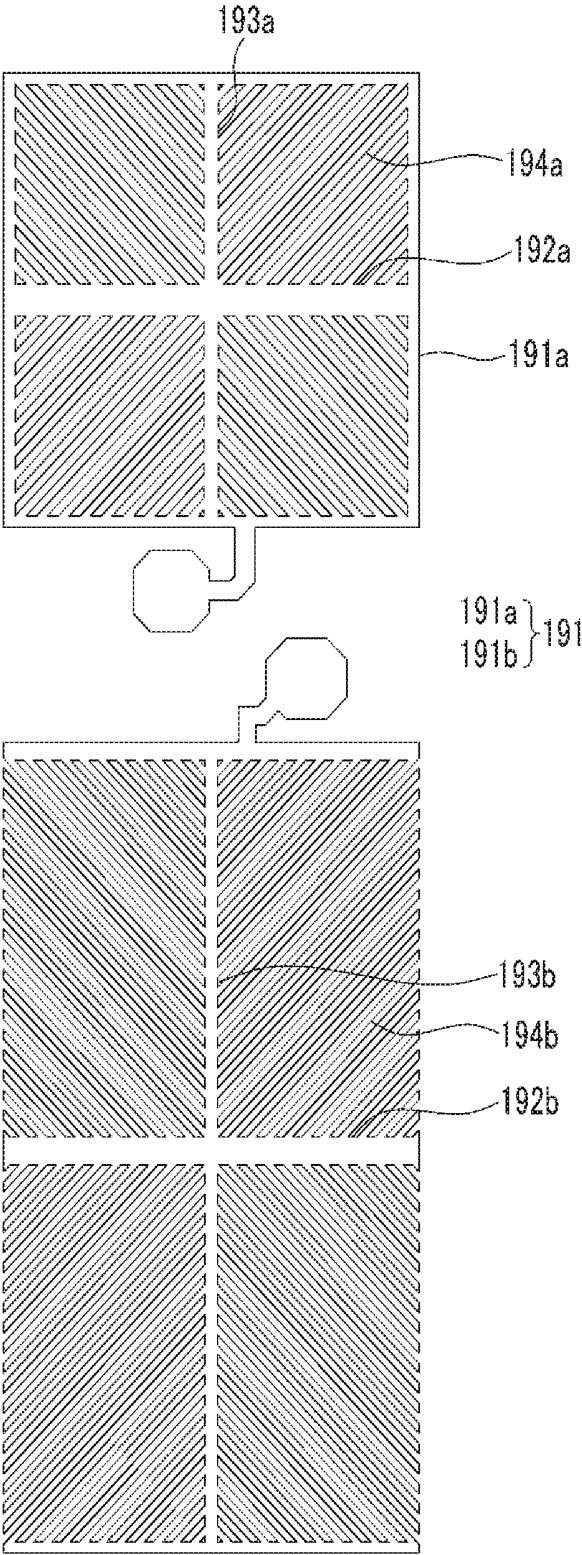

FIG.25

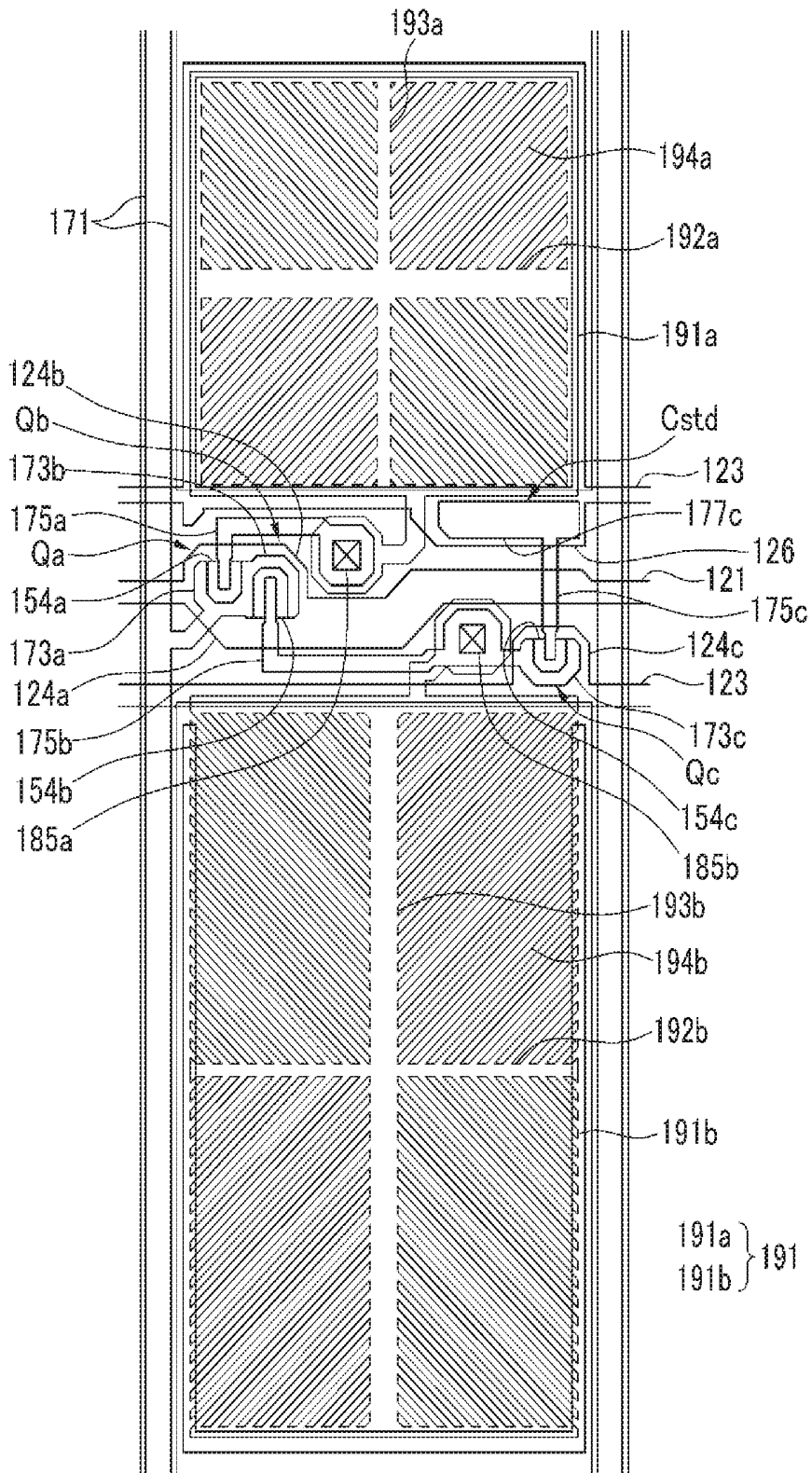

FIG.26

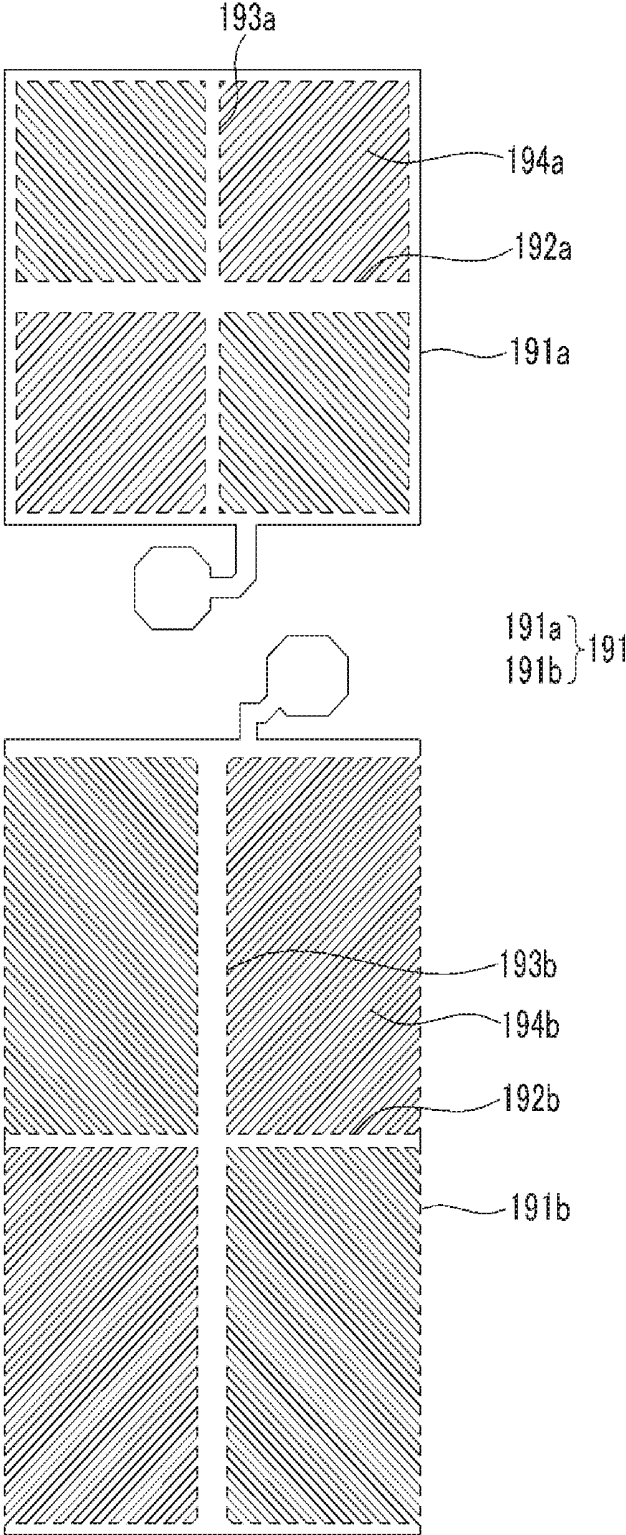
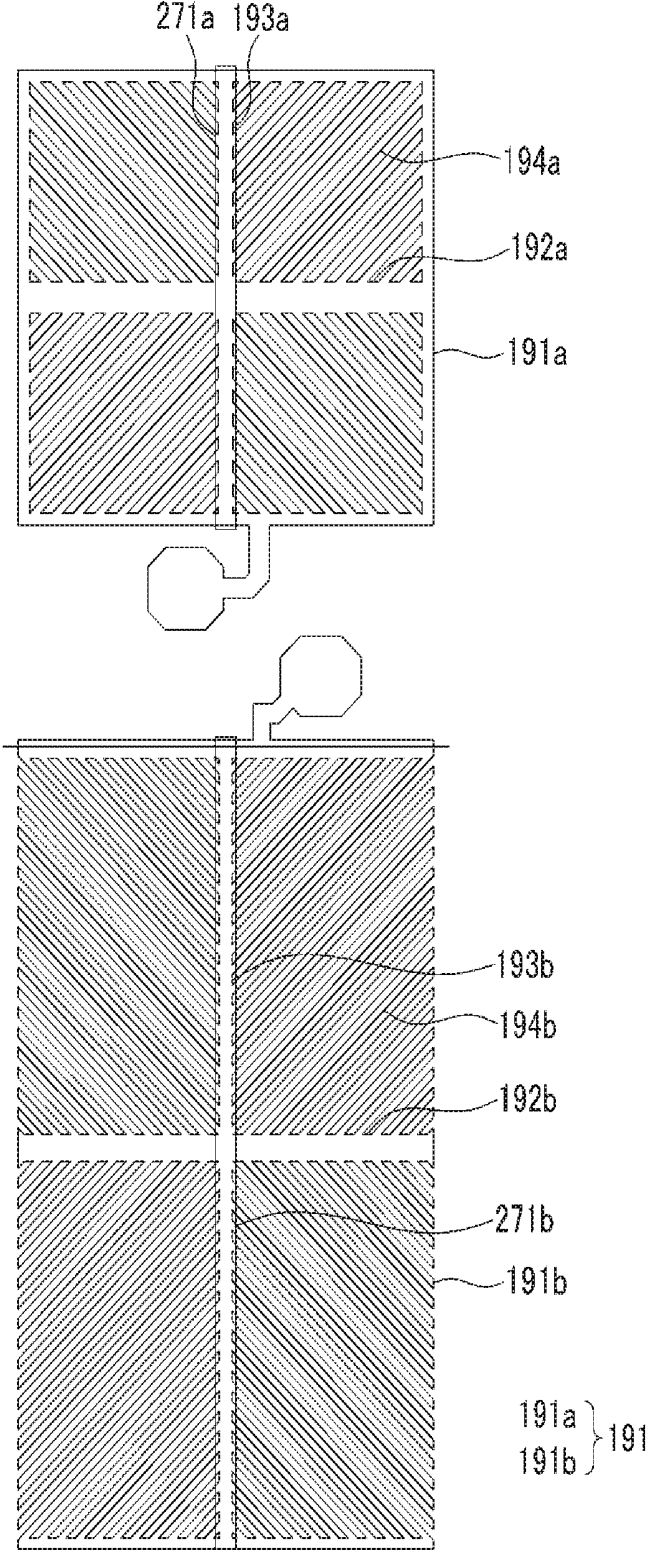

FIG.28



**LIQUID CRYSTAL DISPLAY COMPRISING A
PIXEL ELECTRODE HAVING A
TRANSVERSE STEM, A LONGITUDINAL
STEM, AND A PLURALITY OF MINUTE
BRANCHES**

**CROSS-REFERENCE TO RELATED
APPLICATION**

[0001] This application is a Continuation of Ser. No. 15/144,280, filed on May 2, 2016, which is a Continuation of Ser. No. 14/931,312, filed on Nov. 3, 2015, now issued as U.S. Pat. No. 9,329,442, which is a Divisional of U.S. patent application Ser. No. 13/835,941, filed on Mar. 15, 2013, now issued as U.S. Pat. No. 9,213,209, and claims priority from and the benefit of Korean Patent Application No. 10-2012-0086332, filed on Aug. 7, 2012, which are hereby incorporated by reference for all purposes as if fully set forth herein.

BACKGROUND

[0002] Field

[0003] Exemplary embodiments of the present invention relate to a liquid crystal display.

[0004] Discussion of the Background

[0005] A liquid crystal display is one of several types of flat panel displays that are now widely used. The liquid crystal display includes two display panels in which field generating electrodes, such as pixel electrodes and a common electrode, are formed, and a liquid crystal layer is interposed between the display panels. In the liquid crystal display, a voltage is applied to the field generating electrodes to generate an electric field in the liquid crystal layer, which determines the orientation direction of liquid crystal molecules of the liquid crystal layer, and an image is displayed by controlling the polarization of incident light.

[0006] Among the types of liquid crystal displays, a vertically aligned mode liquid crystal display has become popular. In this type of display the long axes of the liquid crystal molecules are arranged to be perpendicular to the display panel in the state in which an electric field is not applied, thereby resulting in a high contrast ratio and a wide reference viewing angle thereof. A reference viewing angle is defined as a viewing angle that results in a contrast ratio equal to 1:10 or as a limit angle for inversion in luminance between grays.

[0007] In order to increase side visibility quality to the level of front visibility quality in the vertical alignment mode LCD, a method of causing a difference in transmittance by dividing one pixel into two sub-pixels and applying different voltages to the two sub-pixels has been suggested.

[0008] However, when increasing the side visibility quality to the level of front visibility quality by dividing one pixel into two subpixels and forming different transmittances, the luminance is increased at a low gray scale or high gray scale such that gray scale expression is difficult from the side, thereby deteriorating display quality.

[0009] The above information disclosed in this Background section is only for enhancement of understanding of the background of the invention and therefore it may contain information that does not form the prior art that is already known in this country to a person of ordinary skill in the art.

SUMMARY OF THE INVENTION

[0010] Exemplary embodiments of the present invention provide a liquid crystal display which produces an accurate gray scale in a low gray scale region while producing side visibility quality which is close to front visibility quality.

[0011] Additional features of the invention will be set forth in the description which follows, and in part will be apparent from the description, or may be learned by practice of the invention.

[0012] Exemplary embodiments of the present invention provide a liquid crystal display including a first substrate; a pixel electrode disposed on the first substrate and including a first subpixel electrode and a second subpixel electrode disposed in one pixel area; a second substrate facing the first substrate; and a common electrode disposed on the second substrate. An area of a region occupied by the first subpixel electrode is less than an area of a region occupied by the second subpixel electrode. The first subpixel electrode may include a first transverse stem, a first longitudinal stem, and a plurality of first minute branches extending from the first transverse stem and the first longitudinal stem. The second subpixel electrode may include a second transverse stem, a second longitudinal stem, and a plurality of second minute branches extending from the second transverse stem and the second longitudinal stem. A width of the first transverse stem of the first subpixel electrode is greater than the width of the first longitudinal stem of the first subpixel electrode, and the first transverse stem has a plurality of first cutouts parallel to the first minute branches and disposed at a predetermined interval.

[0013] The width of the second transverse stem of the second subpixel electrode may be substantially the same as the width of the second longitudinal stem of the second subpixel electrode.

[0014] A liquid crystal layer injected between the first substrate and the second substrate may be further included, and liquid crystal molecules of the liquid crystal layer may be arranged to be substantially perpendicular to a surface of the first substrate and the second substrate when an electric field is not generated between the pixel electrode and the common electrode.

[0015] An alignment layer disposed on at least one of the first substrate and the second substrate may be further included, and at least one of the liquid crystal layer and the alignment layer may include a light reactive material.

[0016] The width of the second transverse stem of the second subpixel electrode may be wider than of the width of the second longitudinal stem of the second subpixel electrode.

[0017] The width of the second transverse stem of the second subpixel electrode may be narrower than the width of the second longitudinal stem of the second subpixel electrode.

[0018] The common electrode may have a second cutout formed at a position corresponding to the first longitudinal stem.

[0019] The common electrode may have a third cutout formed at a position corresponding to the second longitudinal stem.

[0020] Exemplary embodiments of the present invention also provide a liquid crystal display including a first substrate; a pixel electrode disposed on the first substrate and including a first subpixel electrode and a second subpixel electrode disposed in one pixel area; a second substrate

facing the first substrate; and a common electrode disposed on the second substrate. An area of a region occupied by the first subpixel electrode is less than an area of a region occupied by the second subpixel electrode. The first subpixel electrode may include a first transverse stem, a first longitudinal stem, and a plurality of first minute branches extending from the first transverse stem and the first longitudinal stem. The second subpixel electrode may include a second transverse stem, a second longitudinal stem, and a plurality of second minute branches extending from the second transverse stem and the second longitudinal stem. The common electrode has a first cutout formed at a position corresponding to the first longitudinal branch of the first subpixel electrode.

[0021] The width of the first transverse stem of the first subpixel electrode may be substantially the same as the width of the first longitudinal stem of the first subpixel electrode.

[0022] The common electrode may further have a second cutout formed at a position corresponding to the second longitudinal stem or the second transverse stem of the second subpixel electrode.

[0023] In the liquid crystal display according to an exemplary embodiment of the present invention, the pixel electrode disposed in one pixel area is divided into the first subpixel electrode and the second subpixel electrode, the first subpixel electrode and the second subpixel electrode have the cross-shaped stem and a plurality of minute branches extending therefrom, and the width of the transverse stem of the first subpixel electrode is wider than the width of the longitudinal stem of the first subpixel electrode such that the luminance of the liquid crystal display is reduced in the low gray region and the high gray region, and as a result, the correct gray expression is possible in the low gray region and the high gray region and the lateral visibility may be close to the front visibility.

[0024] It is to be understood that both the foregoing general description and the following detailed description are exemplary and explanatory and are intended to provide further explanation of the invention as claimed.

BRIEF DESCRIPTION OF THE DRAWINGS

[0025] The accompanying drawings, which are included to provide a further understanding of the invention and are incorporated in and constitute a part of this specification, illustrate embodiments of the invention, and together with the description serve to explain the principles of the invention.

[0026] FIG. 1 is an equivalent circuit diagram of one pixel of a liquid crystal display according to an exemplary embodiment of the present invention.

[0027] FIG. 2 is a layout view of the liquid crystal display according to an exemplary embodiment of the present invention.

[0028] FIG. 3 is a cross-sectional view of the liquid crystal display of FIG. 2 taken along line III-III.

[0029] FIG. 4 is a top plan view illustrating a basic region of a field generating electrode of the liquid crystal display according to an exemplary embodiment of the present invention.

[0030] FIG. 5 is a top plan view of one base region of a pixel electrode shown in the liquid crystal display of FIG. 2.

[0031] FIG. 6 is a layout view of a liquid crystal display according to another exemplary embodiment of the present invention.

[0032] FIG. 7 is a top plan view of one base region of a pixel electrode shown in the liquid crystal display of FIG. 6.

[0033] FIG. 8 is a schematic view illustrating an operation of liquid crystal molecules of the liquid crystal display shown in FIG. 6 and FIG. 7.

[0034] FIG. 9 is a layout view of the liquid crystal display according to another exemplary embodiment of the present invention.

[0035] FIG. 10 is a top plan view of one base region of a pixel electrode shown in the liquid crystal display of FIG. 9.

[0036] FIG. 11 is a layout view of the liquid crystal display according to another exemplary embodiment of the present invention.

[0037] FIG. 12 is a top plan view of one base region of a pixel electrode shown in the liquid crystal display of FIG. 11.

[0038] FIG. 13 is a layout view of the liquid crystal display according to another exemplary embodiment of the present invention.

[0039] FIG. 14 is a top plan view of one base region of a field generating electrode shown in the liquid crystal display of FIG. 13.

[0040] FIG. 15 is a layout view of the liquid crystal display according to another exemplary embodiment of the present invention.

[0041] FIG. 16 is a top plan view of one base region of a field generating electrode shown in the liquid crystal display of FIG. 15.

[0042] FIG. 17 is an equivalent circuit diagram of one pixel of a liquid crystal display according to another exemplary embodiment of the present invention.

[0043] FIG. 18 is a layout view of the liquid crystal display according to another exemplary embodiment of the present invention.

[0044] FIG. 19 is a cross-sectional view of the liquid crystal display of FIG. 18 taken along line XIX-XIX.

[0045] FIG. 20 is a top plan view of one base region of a pixel electrode shown in the liquid crystal display of FIG. 18.

[0046] FIG. 21 is a layout view of the liquid crystal display according to another exemplary embodiment of the present invention.

[0047] FIG. 22 is a top plan view of one base region of a pixel electrode shown in the liquid crystal display of FIG. 21.

[0048] FIG. 23 is a layout view of the liquid crystal display according to another exemplary embodiment of the present invention.

[0049] FIG. 24 is a top plan view of one base region of a pixel electrode shown in the liquid crystal display of FIG. 23.

[0050] FIG. 25 is a layout view of the liquid crystal display according to another exemplary embodiment of the present invention.

[0051] FIG. 26 is a top plan view of one base region of a pixel electrode shown in the liquid crystal display of FIG. 25.

[0052] FIG. 27 is a layout view of the liquid crystal display according to another exemplary embodiment of the present invention.

[0053] FIG. 28 is a top plan view of one base region of a pixel electrode shown in the liquid crystal display of FIG. 27.

DETAILED DESCRIPTION OF THE ILLUSTRATED EMBODIMENTS

[0054] The invention is described more fully hereinafter with reference to the accompanying drawings, in which embodiments of the invention are shown. This invention may, however, be embodied in many different forms and should not be construed as limited to the embodiments set forth herein. Rather, these embodiments are provided so that this disclosure is thorough, and will fully convey the scope of the invention to those skilled in the art.

[0055] In the drawings, the thickness of layers, films, panels, regions, etc., are exaggerated for clarity. Like reference numerals in the drawings denote like elements. It will be understood that when an element, such as a layer, film, region, or substrate is referred to as being “on” another element, it can be directly on the other element or intervening elements may also be present. In contrast, when an element is referred to as being “directly on” another element, there are no intervening elements present. It will be understood that for the purposes of this disclosure, “at least one of X, Y, and Z” can be construed as X only, Y only, Z only, or any combination of two or more items X, Y, and Z (e.g., XYZ, XYY, YZ, ZZ).

[0056] A liquid crystal display according to an exemplary embodiment of the present invention will be described with reference to FIG. 1, which is an equivalent circuit diagram of one pixel of a liquid crystal display.

[0057] Referring to FIG. 1, one pixel PX of the liquid crystal display according to the exemplary embodiment of the present invention includes a plurality of signal lines including a gate line GL transmitting a gate signal, a data line DL transmitting a data signal, and a reference voltage line RL transmitting a divided reference voltage. A first switching element Qa, a second switching element Qb, a third switching element Qc, a first liquid crystal capacitor Clca, and a second liquid crystal capacitor Clcb are connected to the plurality of signal lines.

[0058] The first switching element Qa and the second switching element Qb are respectively connected to the gate line GL and the data line DL, and the third switching element Qc is connected to the output terminal of the second switching element Qb and the reference voltage line RL.

[0059] The first switching element Qa and the second switching element Qb are three-terminal thin film transistors, and control terminals thereof are connected to the gate line GL, input terminals are connected to the data line DL, an output terminal of the first switching element Qa is connected to the first liquid crystal capacitor Clca, and an output terminal of the second switching element Qb is connected to input terminals of the second liquid crystal capacitor Clcb and the third switching element Qc.

[0060] The third switching element Qc is also a three-terminal thin film transistor, and a control terminal thereof is connected to the gate line GL, an input terminal is connected to the second liquid crystal capacitor Clcb, and an output terminal is connected to the reference voltage line RL.

[0061] When a gate-on signal is applied to the gate line GL, the first switching element Qa, the second switching element Qb, and the third switching element Qc that are connected thereto are turned on. Accordingly, the data

voltage applied to the data line DL is respectively applied to a first electrode PEa and a second electrode PEb through the first switching element Qa and the second switching element Qb that are turned on. In this case, the data voltages applied to the first electrode PEa and the second electrode PEb may be charged at the same value. However, according to the exemplary embodiment of the present invention, the voltage applied to the second electrode PEb is divided through the third switching element Qc connected with the second switching element Qb in series. Accordingly, the voltage Vb applied to the second electrode PEb is smaller than the voltage Va applied to the first electrode PEa.

[0062] As a result, the voltage charged to the first liquid crystal capacitor Clca and the voltage charged to the second liquid crystal capacitor Clcb are different from each other such that the inclined angle of the liquid crystal molecules in the first subpixel is different from the inclined angle of the liquid crystal molecules in the second subpixel, thereby changing the luminance of the two subpixels. Therefore, when the charging voltages of the first and second liquid crystal capacitors Clca and Clcb are appropriately adjusted, it is possible to make an image viewed from the side be as similar as possible to an image viewed from the front, and as a result it is possible to improve the side visibility quality.

[0063] As described, when the voltage charged to the first liquid crystal capacitor Clca and the voltage charged to the second liquid crystal capacitor Clcb are different, in a low gray scale region where a magnitude of the data voltage is relatively low, the first liquid crystal capacitor Clca connected to the first subpixel electrode Pea, to which the relatively large voltage is applied, is charged with the charge. However, the second liquid crystal capacitor Clcb connected to the second subpixel electrode PEb applied with a voltage lower than the applied data voltage may not be charged with the charge. Therefore, in the low gray scale region where the applied data voltage is low, the brightness of the pixel PX is determined by the first subpixel electrode PEa.

[0064] Next, a structure of the liquid crystal display according to the exemplary embodiment shown in FIG. 1 will be described with reference to FIG. 2 and FIG. 3. FIG. 2 is a layout view of the liquid crystal display according to the exemplary embodiment of the present invention, and FIG. 3 is a cross-sectional view of the liquid crystal display of FIG. 2 taken along line III-III.

[0065] Referring to FIG. 2 and FIG. 3, the liquid crystal display according to the present exemplary embodiment includes a lower panel 100 and an upper panel 200 facing each other, and a liquid crystal layer 3 interposed between the two display panels 100 and 200.

[0066] First, the lower panel 100 will be described.

[0067] A gate line 121, a reference voltage line 131, and storage electrodes 135, 136, 138, and 139 are formed on an insulation substrate 110 made of transparent glass or plastic. The gate line 121 transfers a gate signal and mainly extends in a longitudinal direction.

[0068] The gate line 121 includes a first gate electrode 124a, a second gate electrode 124b, a third gate electrode 124c, and a wide end (not shown) for connection with other layers and an external driving circuit.

[0069] The reference voltage line 131 may extend parallel to the gate line 121 and has an expansion 137, and the expansion 137 is connected to a third drain electrode 175c that will be described later.

[0070] The reference voltage line 131 may include first storage electrodes 135 and 136 enclosing the first subpixel electrode 191a.

[0071] A second subpixel electrode 191b may be enclosed by the second storage electrodes 138 and 139.

[0072] A gate insulating layer 140 is formed on the gate line 121, the reference voltage line 131, and the storage electrodes 135, 136, 138, and 139.

[0073] A first semiconductor 154a, a second semiconductor 154b, and a third semiconductor 154c that may be made of amorphous silicon or crystalline silicon are positioned on the gate insulating layer 140.

[0074] A plurality of ohmic contacts 164b are formed on the first semiconductor 154a, the second semiconductor 154b, and the third semiconductor 154c. When the semiconductors 154a, 154b, and 154c are formed with an oxide semiconductor, the ohmic contact may be omitted.

[0075] Data conductors 171, 173a, 173b, 173c, 175a, 175b, and 175c, which include a data line 171 having a first source electrode 173a and a second source electrode 173b, a first drain electrode 175a, a second drain electrode 175b, a third source electrode 173c, and a third drain electrode 175c are formed on the ohmic contact and the gate insulating layer 140.

[0076] The second drain electrode 175b is connected to the third source electrode 173c.

[0077] The first gate electrode 124a, the first source electrode 173a, and the first drain electrode 175a form a first thin film transistor Qa along with the first semiconductor 154a, and a channel of the first thin film transistor Qa is formed in the first semiconductor 154a between the first source electrode 173a and the first drain electrode 175a. Similarly, the second gate electrode 124b, the second source electrode 173b, and the second drain electrode 175b form a second thin film transistor Qb along with the second semiconductor 154b, and a channel of the second thin film transistor Qb is formed in the second semiconductor 154b between the second source electrode 173b and the second drain electrode 175b. Similarly, the third gate electrode 124c, the third source electrode 173c, and the third drain electrode 175c form a third thin film transistor Qc along with the third semiconductor 154c, and a channel of the third thin film transistor Qc is formed in the third semiconductor 154c between the third source electrode 173c and the third drain electrode 175c.

[0078] A lower passivation layer 180p that may be made of an inorganic insulator such as silicon nitride or silicon oxide is formed on the data conductors 171, 173a, 173b, 173c, 175a, 175b, and 175c and the exposed semiconductor portions 154a, 154b, and 154c.

[0079] A color filter 230 is positioned on the lower passivation layer 180p. The color filter 230 is positioned over most of the region except for the position where the first thin film transistor Qa, the second thin film transistor Qb, and the third thin film transistor Qc are disposed.

[0080] A light blocking member (not shown) may be positioned on a region where the color filter 230 is not positioned and on a portion of the color filter 230. The light blocking member is referred to as a black matrix and prevents light leakage.

[0081] An upper passivation layer 180q is formed on the color filter 230 and the light blocking member. The upper passivation layer 180q prevents peeling of the color filter 230 and the light blocking member, and suppresses con-

tamination of the liquid crystal layer 3 by an organic material of the solvent that inflows from the color filter 230, so that it prevents defects, such as afterimages, which may occur when an image is driven.

[0082] The lower passivation layer 180p, the light blocking member, and the upper passivation layer 180q have a first contact hole 185a and a second contact hole 185b exposing the first drain electrode 175a and the second drain electrode 175b, and the lower passivation layer 180p, the light blocking member, the upper passivation layer 180q, and the gate insulating layer 140 have a third contact hole 185c exposing the expansion 137 of the reference voltage line 131 and the third drain electrode 175c.

[0083] A pixel electrode 191 including a first subpixel electrode 191a and a second subpixel electrode 191b, and a shielding electrode line 88p, are formed on the upper passivation layer 180q. The pixel electrode 191 may be formed of a transparent conductive material such as ITO or IZO, or a reflective metal such as aluminum, silver, chromium, or alloys thereof.

[0084] Each pixel electrode 191 includes the first subpixel electrode 191a and the second subpixel electrode 191b, which are separated from each other with the gate line 121 and the reference voltage line 131 interposed therebetween, and disposed above and below the pixel area so as to be adjacent to each other in a column direction. That is, one pixel area includes a first subpixel area where the first subpixel electrode 191a is disposed and a second subpixel area where the second subpixel electrode 191b is disposed, and the area of the second subpixel area where the second subpixel electrode 191b is disposed is greater than the area of the first subpixel area where the first subpixel electrode 191a is disposed.

[0085] The first sub-pixel electrode 191a and the second sub-pixel electrode 191b include one or more basic electrodes 199, or modifications thereof, as shown in FIG. 4. The first subpixel electrode 191a may include a cross-shaped stem including a first transverse stem 192a and a first longitudinal stem 193a and a plurality of first minute branches 194a extending therefrom, and the second subpixel electrode 191b may include a cross-shaped stem including a second transverse stem 192b and a second longitudinal stem 193b and a plurality of second minute branches 194b extending therefrom.

[0086] Data voltages are respectively applied to the first subpixel electrode 191a and the second subpixel electrode 191b from the first drain electrode 175a and the second drain electrode 175b through the first contact hole 185a and the second contact hole 185b. The data voltage voltages applied to the first subpixel electrode 191a and the second subpixel electrode 191b form an electric field along with a common electrode 270 of the upper panel 200 such that the electric field determines the direction of liquid crystal molecules in the liquid crystal layer 3 between two electrodes 191 and 270. Accordingly, the luminance of the light transmitted through the liquid crystal layer 3 differs depending on the thusly determined orientation of the liquid crystal molecules.

[0087] The shielding electrode line 88p includes a shielding electrode 88 extending according to the data line 171 and protruding toward the gate line 121. A portion of the shielding electrode line 88p covers the third contact hole 185c exposing the expansion 137 of the reference voltage line 131 and the third drain electrode 175c, and thereby the

expansion 137 of the reference voltage line 131 is electrically connected to the third drain electrode 175c.

[0088] Next, the upper panel 200 will be described.

[0089] A common electrode 270 is formed on an insulating substrate 210 made of a material such as transparent glass or plastic.

[0090] However, the liquid crystal display according to another exemplary embodiment of the present invention may include a light blocking member and a color filter (both not shown) formed on the insulation substrate 210.

[0091] Alignment layers (not shown) may be formed on inner surfaces of the display panels 100 and 200, and they may be vertical alignment layers.

[0092] A polarizer (not shown) may be provided on the outer surface of the two display panels 100 and 200, and the transmissive axes of the two polarizers may be orthogonal to each other and any one transmissive axis of is the two polarizers may be parallel to the gate line 121. However, the polarizer may only be disposed at one outer surface of the two display panels 100 and 200.

[0093] The liquid crystal layer 3 has negative dielectric anisotropy, and the liquid crystal molecules of the liquid crystal layer 3 may be aligned so that long axes thereof are vertical with respect to the surface of the two display panels 100 and 200 in a state in which there is no electric field. Therefore, the incident light may not pass through the crossed polarizers and is therefore blocked in a state in which there is no electric field.

[0094] At least one of the liquid crystal layer 3 and the alignment layer may include a photoreactive material, which may be a reactive mesogen.

[0095] As described above, because the first sub-pixel electrode 191a and the second sub-pixel electrode 191b to which the data voltage is applied generate an electric field in conjunction with the common electrode 270 of the upper panel 200, the liquid crystal molecules of the liquid crystal layer 3, which are aligned vertically with respect to the surfaces of the two electrodes 191 and 270 in a state in which there is no electric field, lie in a horizontal direction with respect to the surfaces of the two electrodes 191 and 270, and the luminance of light that passes through the liquid crystal layer 3 is changed according to the degree of tilt of the liquid crystal molecules.

[0096] Hereinafter, referring to FIG. 4, the basic electrode 199 will be described in detail. FIG. 4 is a top plan view illustrating a basic region of a field generating electrode of the liquid crystal display according to the exemplary embodiment of the present invention.

[0097] As shown in FIG. 4, the entire shape of the basic electrode 199 is quadrangular, and the basic electrode 199 may include a cross-shaped stem that is formed of a transverse stem portion 192 and a longitudinal stem portion 193 that is perpendicular thereto. In addition, the basic electrode 199 is divided into a first subregion Da, a second subregion Db, a third subregion Dc, and a fourth subregion Dd by the transverse stem portion 192 and the longitudinal stem portion 193, and each subregion Da-Dd includes a plurality of third minute branches 194aa, a plurality of fourth minute branches 194bb, a plurality of fifth minute branches 194cc, and a plurality of sixth minute branches 194dd, respectively.

[0098] The third minute branches 194aa obliquely extend from the transverse stem 192 or the longitudinal stem 193 in the upper-left direction, and the fourth minute branches 194bb obliquely extend from the transverse stem 192 or the

longitudinal stem 193 in the upper-right direction. The fifth minute branches 194cc obliquely extend from the transverse stem 192 or the longitudinal stem 193 in the lower-left direction, and the sixth minute branches 194dd obliquely extend from the transverse stem 192 or the longitudinal stem 193 in the lower-right direction.

[0099] The third to sixth minute branches 194aa, 194bb, 194cc, and 194dd form an angle of about 45 degrees or 135 degrees with the gate line 121 or the transverse stem 192. The third to sixth minute branches 194aa, 194bb, 194cc, and 194dd of two neighboring subregions Da-Dd may be crossed.

[0100] According to another embodiment of the present invention, the widths of the third to sixth minute branches 194aa, 194bb, 194cc, and 194dd may increase or decrease closer to the transverse stem 192 or the longitudinal stem 192.

[0101] If the voltage is applied to the first subpixel electrode 191a and the second subpixel electrode 191b, the edges of the minute branches 194aa, 194bb, 194cc, and 194dd induce a fringe field which distorts the electric field, thereby forming a horizontal component that determines an inclination direction of the liquid crystal molecules. The horizontal components of the electric field are substantially horizontal to the sides of the third to sixth minute branches 194aa, 194bb, 194cc, and 194dd. Therefore, as shown in FIG. 4, the liquid crystal molecules 31 are inclined in a direction that is parallel to a length direction of the third to sixth minute branches 194aa, 194bb, 194cc, and 194dd. The liquid crystal molecules 31 disposed at the position corresponding to the transverse stem 192 and the longitudinal stem 193 of the cross-shaped stem are inclined in the direction parallel to the direction that the transverse stem 192 and the longitudinal stem 193 extend.

[0102] Because one pixel electrode 191 includes four subregions Da to Dd in which length directions of the third to sixth minute branches 194aa, 194bb, 194cc, and 194dd are different from each other, there are about four directions in which the liquid crystal molecules 31 may be inclined, and four domains in which the alignment directions of the liquid crystal molecules 31 are different from each other are formed in the liquid crystal layer 3. As described above, by diversifying the inclination direction of the liquid crystal molecules, the standard viewing angle of the liquid crystal display may be increased.

[0103] Next, a base region of a pixel electrode of the liquid crystal display shown in FIG. 2 will be described with reference to FIG. 5. FIG. 5 is a top plan view of a base region of a pixel electrode of the liquid crystal display shown in FIG. 2.

[0104] Referring to FIG. 5 as well as FIG. 2, the first subpixel electrode 191a of the liquid crystal display according to the present exemplary embodiment is similar to the basic electrode 199 shown in FIG. 4. The first subpixel electrode 191a may include the cross-shaped stem, including the first transverse stem 192a and the first longitudinal stem 193a and a plurality of first minute branches 194a extending therefrom. A first width W1 of the first transverse stem 192a of the first subpixel electrode 191a is greater than a second width W2 of the first longitudinal stem 193a. The first width W1 of the first transverse stem 192a of the first subpixel electrode 191a may be greater than the second width W2 of the first longitudinal stem 193a by about 1 μm to about 3 μm . In contrast, the widths of the second trans-

verse stem **192b** and the second longitudinal stem **193b** of the second subpixel electrode **191b** are substantially the same. That is, the width of the first transverse stem **192a** of the first subpixel electrode **191a** is greater than the width of both the second transverse stem **192b** and the second longitudinal stem **193b** of the second subpixel electrode **191b** and the width of the first longitudinal stem **193a** of the first subpixel electrode **191a**.

[0105] The first transverse stem **192a** of the first subpixel electrode **191a** of the liquid crystal display according to the present exemplary embodiment may be partially disconnected. Accordingly, referring to FIGS. **4** and **5**, a portion of a plurality of cutouts defining the third minute branches **194aa** of the first subregion Da and the portion of a plurality of cutouts defining the fifth minute branches **194cc** of the third subregion Dc may be connected to each other. Similarly, a portion of a plurality of cutouts defining the fourth minute branches **194bb** of the second subregion Db and the first cutouts **92a** among a plurality of cutouts defining the sixth minute branches **194dd** of the fourth subregion Dd may be connected to each other. Referring to FIG. **5**, the first cutouts **92a** extend in a direction parallel to the first minute branches **194a** from a portion adjacent to the edge parallel to the data line **171** among an outer edge of the first subpixel electrode **191a**, pass the first stem **192a** of the first subpixel electrode **191a** and bends about 90 degrees, and then again extends to a portion adjacent to the edge parallel to the data line **171**. That is, the first cutouts **92a** among a plurality of cutouts defining the first minute branches **194a** of the first subpixel electrode **191a** are also formed in the first stem **192a** of the first subpixel electrode **191a**. The first cutouts **92a** are formed at a predetermined interval to the first transverse stem **192a**.

[0106] As described above, the voltage is applied to the first subpixel electrode **191a**, and the liquid crystal molecules **31** disposed at the position corresponding to the cross-shaped stem including the first transverse stem **192a** and the first longitudinal stem **193a** are inclined in the same direction as the direction in which the first transverse stem **192a** and the first longitudinal stem **193a** extend. Accordingly, the slant direction of the liquid crystal molecules **31a** disposed at the position corresponding to the cross-shaped stem including the first transverse stem **192a** and the first longitudinal stem **193a** is a direction parallel to the transmissive axis (not shown) of the polarization layer, and accordingly, the light passing through the liquid crystal layer **3** is blocked, thereby forming a region in which the image may not be displayed. Accordingly, when the width of the first transverse stem **192a** is increased, the brightness of the light passing through the liquid crystal layer **3** may be reduced in the region occupied by the first subpixel electrode **191a**. In the liquid crystal display according to an exemplary embodiment of the present invention, the portion of a plurality of cutouts defining the first minute branches **194a** of the first subpixel electrode **191a** is formed in the first transverse stem **192a**. Accordingly, because of the presence of the first cutouts **92a** of the first transverse stem **192a**, the second liquid crystal molecules **31b** disposed in the region in which the first transverse stem **192a** of the first subpixel electrode **191a** is disconnected meet and collapse toward each other in the longitudinal center portion of the first subpixel electrode **191a**, thereby slanting according to the direction parallel to the direction in which the first transverse stem **192a** extends. In this way, the first cutouts **92a** disposed

at a uniform interval are formed in the partial region of the first transverse stem **192a** of the first subpixel electrode **191a** such that the number of liquid crystal molecules slanted in the direction parallel to the first transverse stem **192a** of the first subpixel electrode **191a** may be increased.

[0107] As described above, in the low gray scale region where the magnitude of the data voltage is small, the electric field is applied in the region corresponding to the first subpixel electrode **191a** where the applied voltage is relatively large. However, the electric field may not be applied in the region corresponding to the second subpixel electrode **191b** charged with a voltage less than the magnitude of the applied data voltage. Accordingly, in the low gray scale region where the magnitude of the data voltage is small, the brightness of the pixel is determined by the brightness of the first subpixel electrode **191a**.

[0108] In the first subpixel electrode **191a** of the liquid crystal display according to the present exemplary embodiment, the width of the first transverse stem **192a** among the cross-shaped stems is greater than the width of the first longitudinal stem **193a**, and the first transverse stem **192a** has the first cutouts **92a** extending in parallel to the first minute branches **194a** such that the number of liquid crystal molecules slanted according to the first transverse stem **192a** of the first subpixel electrode **191a** may be increased. Accordingly, the brightness of the region corresponding to the first subpixel electrode **191a** may be reduced. Accordingly, in the low gray scale region, the brightness of the entire pixel may be reduced. Therefore, the luminance of the liquid crystal display may be decreased in the low gray scale region such that the correct gray scale expression is possible in the low gray scale region.

[0109] The number of liquid crystal molecules **31** slanted in the direction parallel to the extending direction of the first transverse stem **192a** is greater than the number of liquid crystal molecules **31** slanted in the direction parallel to the extending direction of the first longitudinal stem **193a**. When viewing the liquid crystal molecules **31** slanted in the direction parallel to the extending direction of the first transverse stem **192a** from the left side and the right side of the liquid crystal display, the direction of the short axis of the liquid crystal molecules **31** is reorganized. When viewing the liquid crystal molecules **31** slanted in the direction parallel to the extending direction of the first longitudinal stem **193a** at the left side and the right side of the liquid crystal display, the direction of the long axis of the liquid crystal molecules **31** is reorganized. Accordingly, in the liquid crystal display according to the present exemplary embodiment, the luminance of the region occupied by the first subpixel electrode **191a** may be decreased, and simultaneously, when viewing the liquid crystal display from either the right side or the left side, the short axis of the liquid crystal molecules **31** is reorganized more than the long axis such that deterioration in the display quality, such as a stripe, may be prevented, as compared to a case in which the long axis of the liquid crystal molecules **31** is reorganized more than the short axis.

[0110] In this way, in the liquid crystal display according to an exemplary embodiment of the present invention, the pixel electrode disposed in one pixel area is divided into the first subpixel electrode **191a** and the second subpixel electrode **191b**, the first subpixel electrode **191a** and the second subpixel electrode **191b** include the cross-shaped stem and a plurality of minute branches extended therefrom, the first

width **W1** of the first transverse stem **192a** of the first subpixel electrode **191a** is greater than the second the width **W2** of the first longitudinal stem **193a** of the first subpixel electrode **191a**, and the first transverse stem **192a** includes the first cutouts **92a** formed in the direction parallel to the minute branches, thereby discontinuously forming the first transverse stem **192a** such that the luminance of the liquid crystal display may be reduced in the low gray scale region, and as a result, the correct gray scale expression is possible in the low gray scale region and the lateral visibility may be closer to the front visibility. When viewing the liquid crystal display from the side, the short axis of the liquid crystal molecules **31** may be reorganized more than the long axis, thereby preventing deterioration in viewing quality, such as a stripe shape which may be generated in the case of the reorganization of the long axis of the liquid crystal molecule **31**.

[0111] Next, a liquid crystal display according to another exemplary embodiment of the present invention will be described with reference FIG. 6 and FIG. 7. FIG. 6 is a layout view of a liquid crystal display according to another exemplary embodiment of the present invention, and FIG. 7 is a top plan view of one base region of a pixel electrode shown in the liquid crystal display of FIG. 6.

[0112] Referring to FIG. 6 and FIG. 7, the liquid crystal display according to the present exemplary embodiment is similar to the liquid crystal display according to the exemplary embodiment of FIG. 2 to FIG. 5. The description of the same constituent elements is omitted.

[0113] Next, referring to FIG. 7, a shape of the first subpixel electrode **191a** of the liquid crystal display according to the present exemplary embodiment will be described.

[0114] In the liquid crystal display according to the present exemplary embodiment, as opposed to the liquid crystal display according to the exemplary embodiment shown in FIG. 2 to FIG. 5, the first transverse stem **192a** of the first subpixel electrode **191a** may not include the first cutouts **92a**, and the first transverse stem **192a** may be continuously formed. A common electrode **270** of the upper panel **200** has second cutouts **271a** formed at the position corresponding to the first longitudinal stem **193a** of the first subpixel electrode **191a**. The width of the second cutouts **271a** may be in a range of about 2 μm to about 8 μm . According to the liquid crystal display according to another exemplary embodiment of the present invention, the common electrode **270** may further include an additional cutout (not shown) formed at a position corresponding to the second longitudinal stem **193b** of the second subpixel electrode **191b**. According to the liquid crystal display according to another exemplary embodiment of the present invention, the common electrode **270** may further include an additional cutout (not shown) formed at the position corresponding to the second transverse stem **192b** of the second subpixel electrode **191b**.

[0115] In this way, in the case of the liquid crystal display of the present exemplary embodiment, the width of the first transverse stem **192a** of the first subpixel electrode **191a** is greater than the width of the first longitudinal stem **193a**, and the common electrode **270** of the upper panel **200** has the second cutout **271a** at the position corresponding to the first longitudinal stem **193a** of the first subpixel electrode **191a**. Accordingly, the transmittance of the light of the first longitudinal stem **193a** of the first subpixel electrode **191a** is higher than the transmittance of the light of the first transverse stem **192a** of the first subpixel electrode **191a**.

That is, similar to the liquid crystal display according to the exemplary embodiment shown in FIG. 2 to FIG. 5, by reducing the transmittance of the first transverse stem **192a** of the first subpixel electrode **191a**, the entire luminance of the liquid crystal display may be reduced in the low gray scale region such that the correct gray scale expression is possible in the low gray scale region, and the lateral visibility may be close to the front visibility.

[0116] Next, referring to FIG. 8, an operation of the liquid crystal molecules according to the second cutout **271a** of the common electrode **270** of the upper panel **200** will be described. FIG. 8 is a schematic view illustrating an operation of liquid crystal molecules of the liquid crystal display shown in FIG. 6 and FIG. 7.

[0117] In FIG. 8, the operation of the liquid crystal molecules on the transverse stem **192** of the pixel electrode is shown in (a), and the operation of the liquid crystal molecules on the longitudinal stem **193** of the pixel electrode is shown in (b).

[0118] Referring to FIG. 8, in the region corresponding to the transverse stem **192** of the pixel electrode, the common electrode **270** may not have the cutout, but the common electrode may have the cutout **271** in the region corresponding to the longitudinal stem **193** of the pixel electrode.

[0119] As shown, in the region corresponding to the transverse stem **192** of the pixel electrode, the liquid crystal molecules are not influenced by a fringe field formed between the adjacent minute branches **194** and the common electrode **270** such that the liquid crystal molecules are not inclined in the predetermined direction. However, the common electrode **270** has cutouts **271** formed in the region corresponding to the longitudinal stem **193** of the pixel electrode such that the liquid crystal molecules disposed in the region corresponding to the longitudinal stem **193** are influenced by a fringe field generated by the cutouts **271** of the common electrode **270**. Accordingly, the liquid crystal molecules may be inclined in the direction parallel to the adjacent minute branch **194**. Therefore, the transmittance of the region corresponding to the transverse stem of the pixel electrode is lower than the transmittance of the region corresponding to the longitudinal stem of the pixel electrode. Accordingly, in the low gray scale region, the entire luminance of the liquid crystal display may be reduced such that the correct gray scale expression is possible in the low gray scale region, and the lateral visibility may be close to the front visibility.

[0120] Many features of the liquid crystal display according to the exemplary embodiment described with reference to FIG. 2 to FIG. 5 may be applied to the liquid crystal display according to the present exemplary embodiment.

[0121] Next, a liquid crystal display according to another exemplary embodiment of the present invention will be described with reference to FIG. 9 and FIG. 10. FIG. 9 is a layout view of the liquid crystal display according to another exemplary embodiment of the present invention, and FIG. 10 is a top plan view of one base region of a pixel electrode shown in the liquid crystal display of FIG. 9.

[0122] Referring to FIG. 9 and FIG. 10, the liquid crystal display according to the present exemplary embodiment is similar to the liquid crystal display according to the exemplary embodiment of FIG. 2 to FIG. 5. The description of the same constituent elements is omitted.

[0123] In the liquid crystal display according to the present exemplary embodiment, as opposed to the liquid crystal

display according to the exemplary embodiment shown in FIG. 2 to FIG. 5, the common electrode 270 of the upper panel 200 has the second cutout 271a formed at the position corresponding to the first longitudinal stem 193a of the first subpixel electrode 191a. The width of the second cutout 271a may be in a range of about 2 μm to about 8 μm . According to the liquid crystal display according to another exemplary embodiment of the present invention, the common electrode 270 may further include an additional cutout (not shown) formed at the position corresponding to the second longitudinal stem 193b of the second subpixel electrode 191b. According to the liquid crystal display according to another exemplary embodiment of the present invention, the common electrode 270 may further include an additional cutout (not shown) formed at the position corresponding to the second transverse stem 192b of the second subpixel electrode 191b.

[0124] In this way, in the case of the liquid crystal display of the present exemplary embodiment, the width of the first transverse stem 192a of the first subpixel electrode 191a is greater than the width of the first longitudinal stem 193a, the first transverse stem 192a has the first cutout 92a parallel to the first minute branch 194a, and the common electrode 270 of the upper panel 200 has the second cutout 271a formed at the position corresponding to the first longitudinal stem 193a of the first subpixel electrode 191a. Accordingly, the transmittance of the light of the first longitudinal stem 193a of the first subpixel electrode 191a is higher than the transmittance of the light of the first transverse stem 192a of the first subpixel electrode 191a. That is, similar to the liquid crystal display according to the exemplary embodiment shown in FIG. 2 to FIG. 5, by reducing the transmittance of the first transverse stem 192a of the first subpixel electrode 191a, the entire luminance of the liquid crystal display may be reduced in the low gray scale region such that the correct gray scale expression is possible in the low gray scale region, and the lateral visibility may be close to the front visibility.

[0125] Many features of the liquid crystal display according to the exemplary embodiment described with reference to FIG. 2 to FIG. 5 and the liquid crystal display of the exemplary embodiment described with reference to FIG. 6 and FIG. 7 may be applied to the liquid crystal display according to the present exemplary embodiment.

[0126] Next, a liquid crystal display according to another exemplary embodiment of the present invention will be described with reference to FIG. 11 and FIG. 12. FIG. 11 is a layout view of the liquid crystal display according to another exemplary embodiment of the present invention, and FIG. 12 is a top plan view of one base region of a pixel electrode shown in the liquid crystal display of FIG. 11.

[0127] Referring to FIG. 11 and FIG. 12, the liquid crystal display according to the present exemplary embodiment is similar to the liquid crystal display according to the exemplary embodiment of FIG. 2 to FIG. 5. The description of the same constituent elements is omitted.

[0128] However, in the liquid crystal display according to the present exemplary embodiment, as opposed to the liquid crystal display shown in FIG. 2 to FIG. 5, the width of the second transverse stem 192b of the second subpixel electrode 191b is greater than the width of the second longitudinal stem 193b of the second subpixel electrode 191b. The width of the first transverse stem 192a of the first subpixel electrode 191a may be greater than the width of the first

longitudinal stem 193a by about 1 μm to about 3 μm , and the width of the second transverse stem 192b of the second subpixel electrode 191b may be greater than the width of the second longitudinal stem 193b by about 1 μm to about 3 μm . The first transverse stem 192a of the first subpixel electrode 191a may not include the first cutout 92a.

[0129] Accordingly, the first subpixel electrode 191a of the liquid crystal display according to the present exemplary embodiment may include the cross-shaped stem including the first transverse stem 192a and the first longitudinal stem 193a, and a plurality of the first minute branches 194a extending therefrom, and the second subpixel electrode 191b has the cross-shaped stem including the second transverse stem 192b and the second longitudinal stem 193b, and a plurality of the second minute branch 194b extending therefrom.

[0130] The width of the first transverse stem 192a of the first subpixel electrode 191a is greater than the width of the first longitudinal stem 193a, and the width of the second transverse stem 192b of the second subpixel electrode 191b is greater than the width of the second longitudinal stem 193b.

[0131] In the cross-shaped stem of the first subpixel electrode 191a of the liquid crystal display according to the present exemplary embodiment, the width of the first transverse stem 192a is greater than the width of the first longitudinal stem 193a such that the brightness of the region corresponding to the first subpixel electrode 191a may be reduced. Accordingly, in the low gray scale region, the brightness of the entire pixel may be reduced. Therefore, the luminance of the liquid crystal display may be reduced in the low gray scale region such that the correct gray scale expression is possible in the low gray scale region. In the cross-shaped stem of the second subpixel electrode 191b, the width of the second transverse stem 192b is greater than the width of second longitudinal stem 193b to reduce the luminance of the liquid crystal display in the high gray scale region such that the deterioration of the display quality generated according to the increasing of the luminance in the high gray scale region may be prevented.

[0132] In this way, in the liquid crystal display according to an exemplary embodiment of the present invention, the pixel electrode disposed in one pixel area is divided into the first subpixel electrode 191a and the second subpixel electrode 191b, the first subpixel electrode 191a and the second subpixel electrode 191b include the cross-shaped stem and a plurality of minute branches extended therefrom, the width of the first transverse stem 192a of the first subpixel electrode 191a is greater than the width of the first longitudinal stem 193a of the first subpixel electrode 191a, and the width of the second transverse stem 192b of the second subpixel electrode 191b is greater than the width of the second longitudinal stem 193b of the second subpixel electrode 191b such that the luminance of the liquid crystal display may be reduced in the low gray scale region and the high gray scale region. As a result, the correct gray scale expression is possible in the low gray scale region and the high gray scale region, and the lateral visibility may be closer to the front visibility. When viewing the liquid crystal display from the side, the short axis of the liquid crystal molecules 31 may be reorganized more than the long axis, thereby preventing deterioration in viewing quality, such as the stripe shape, which may be generated in the case of the reorganized long axis of the liquid crystal molecule 31.

[0133] Many features of the liquid crystal display according to the exemplary embodiment described with reference to FIG. 2 to FIG. 5 may be applied to the liquid crystal display according to the current exemplary embodiment.

[0134] Next, a liquid crystal display according to another exemplary embodiment of the present invention will be described with reference to FIG. 13 and FIG. 14. FIG. 13 is a layout view of the liquid crystal display according to another exemplary embodiment of the present invention, and FIG. 14 is a top plan view of one base region of a field generating electrode shown in the liquid crystal display of FIG. 13.

[0135] Referring to FIG. 13 and FIG. 14, the liquid crystal display according to the present exemplary embodiment is similar to the liquid crystal display according to the exemplary embodiment of FIG. 2 to FIG. 5. The description of the same constituent elements is omitted.

[0136] However, in the liquid crystal display according to the present exemplary embodiment, as opposed to the liquid crystal display shown in FIG. 2 to FIG. 5, the width of the second longitudinal stem 193b of the second subpixel electrode 191b is greater than the width of the second transverse stem 192b of the second subpixel electrode 191b. The first cutout 92a is not formed in the first transverse stem 192a of the first subpixel electrode 191a.

[0137] Accordingly, the first subpixel electrode 191a of the liquid crystal display according to the present exemplary embodiment includes the cross-shaped stem having the first transverse stem 192a and the first longitudinal stem 193a, and a plurality of the first minute branches 194a extending therefrom, and the second subpixel electrode 191b includes the cross-shaped stem of the second transverse stem 192b and the second longitudinal stem 193b, and a plurality of the second minute branches 194b extending therefrom.

[0138] The width of the first transverse stem 192a of the first subpixel electrode 191a is greater than the width of the first longitudinal stem 193a, and the width of the second longitudinal stem 193b of the second subpixel electrode 191b is greater than the width of the second transverse stem 192b of the second subpixel electrode 191b.

[0139] In the cross-shaped stem of the first subpixel electrode 191a of the liquid crystal display according to the present exemplary embodiment, the width of the first transverse stem 192a is greater than the width of the first longitudinal stem 193a such that the brightness of the region corresponding to the first subpixel electrode 191a may be reduced. Accordingly, in the low gray scale region, the brightness of the entire pixel may be reduced. Therefore, the luminance of the liquid crystal display may be reduced in the low gray scale region such that the correct gray scale expression is possible in the low gray scale region. The width of the second longitudinal stem 193b is greater than the width of the second transverse stem 192b of the second subpixel electrode 191b to reduce the luminance of the liquid crystal display in the high gray scale region such that the deterioration of the display quality generated according to the increasing of the luminance in the high gray scale region may be prevented.

[0140] Many features of the liquid crystal display according to the exemplary embodiment described with reference to FIG. 2 to FIG. 5 may be applied to the liquid crystal display according to the present exemplary embodiment.

[0141] Next, a liquid crystal display according to another exemplary embodiment of the present invention will be

described with reference to FIG. 15 and FIG. 16. FIG. 15 is a layout view of the liquid crystal display according to another exemplary embodiment of the present invention, and FIG. 16 is a top plan view of one base region of a field generating electrode shown in the liquid crystal display of FIG. 15.

[0142] Referring to FIG. 15 and FIG. 16, the liquid crystal display according to the present exemplary embodiment is similar to the liquid crystal display according to the exemplary embodiment of FIG. 2 to FIG. 5, the liquid crystal display according to the exemplary embodiment of FIG. 6 and FIG. 7, and the liquid crystal display according to the exemplary embodiment of 11 and FIG. 12. The description of the same constituent elements is omitted.

[0143] However, in the liquid crystal display according to the present exemplary embodiment, as opposed to the liquid crystal displays according to the previously-described exemplary embodiments, the width of the first transverse stem 192a of the first subpixel electrode 191a is not only greater than the width of the first longitudinal stem 193a, but also the width of the second transverse stem 192b of the second subpixel electrode 191b is greater than the width of the second longitudinal stem 193b. The width of the first transverse stem 192a of the first subpixel electrode 191a may be greater than the width of the first longitudinal stem 193a by about 1 μm to about 3 μm , and the width of the second transverse stem 192b of the second subpixel electrode 191b may be greater than the width of the second longitudinal stem 193b by about 1 μm to about 3 μm . The common electrode 270 of the upper panel 200 has the second cutout 271a formed at the position corresponding to the first longitudinal stem 193a of the first subpixel electrode 191a and the third cutout 271b formed at the position corresponding to the second longitudinal stem 193b of the second subpixel electrode 191b. The width of the second cutout 271a and the third cutout 271b may be in a range of about 2 μm to about 8 μm . However, according to the liquid crystal display according to another exemplary embodiment of the present invention, the third cutout 271b of the common electrode 270 may be omitted. According to the liquid crystal display according to another exemplary embodiment of the present invention, the third cutout 271b of the common electrode 270 is not formed at the position corresponding to the second longitudinal stem 193b of the second subpixel electrode 191b, and may be formed at the position corresponding to the second transverse stem 192b of the second subpixel electrode 191b.

[0144] In this way, in the case of the liquid crystal display according to the present exemplary embodiment, the width of the first transverse stem 192a of the first subpixel electrode 191a is greater than the width of the first longitudinal stem 193a, and the common electrode 270 of the upper panel 200 has the second cutout 271a formed at the position corresponding to the first longitudinal stem 193a of the first subpixel electrode 191a. Accordingly, the transmittance of the light of the first longitudinal stem 193a of the first subpixel electrode 191a is higher than the transmittance of the light of the first transverse stem 192a of the first subpixel electrode 191a. That is, similar to the liquid crystal display according to the exemplary embodiment shown in FIG. 2 to FIG. 5, by reducing the transmittance of the first transverse stem 192a of the first subpixel electrode 191a, the entire luminance of the liquid crystal display may be reduced in the low gray scale region such that the correct gray scale

expression is possible in the low gray scale region, and the lateral visibility may be close to the front visibility.

[0145] In the case of the liquid crystal display according to the present exemplary embodiment, the width of the second transverse stem **192b** of the second subpixel electrode **191b** is greater than the width of the second longitudinal stem **193b**, and the common electrode **270** has the third cutout **271b** formed at the position corresponding to the second longitudinal stem **193b** of the second subpixel electrode **191b**. Accordingly, the transmittance of the light for the second transverse stem **192b** of the second subpixel electrode **191b** is higher than the transmittance of the light for the second longitudinal stem **193b** of the second subpixel electrode **191b**. However, as described above, according to the liquid crystal display according to another exemplary embodiment of the present invention, the third cutout **271b** of the common electrode **270** may be omitted. According to the liquid crystal display according to another exemplary embodiment of the present invention, the third cutout **271b** of the common electrode **270** is not formed at the position corresponding to the second longitudinal stem **193b** of the second subpixel electrode **191b**, and may be formed at the position corresponding to the second transverse stem **192b** of the second subpixel electrode **191b**. Therefore, the luminance of the liquid crystal display may be reduced in the high gray scale region such that the deterioration of the display quality generated according to the increasing of the luminance may be prevented in the high gray scale region.

[0146] Many features of the liquid crystal display according to the present exemplary embodiment are similar to those of the liquid crystal display according to the exemplary embodiment of FIG. 2 to FIG. 5, the liquid crystal display according to the exemplary embodiment of FIG. 6 and FIG. 7, and the liquid crystal display according to the exemplary embodiment of 11 and FIG. 12 so they may be applied to the liquid crystal display of the present exemplary embodiment.

[0147] Next, a liquid crystal display according to another exemplary embodiment of the present invention will be described with reference to FIG. 17 to FIG. 20. FIG. 17 is an equivalent circuit diagram of one pixel of a liquid crystal display according to another exemplary embodiment of the present invention, FIG. 18 is a layout view of the liquid crystal display according to another exemplary embodiment of the present invention, FIG. 19 is a cross-sectional view of the liquid crystal display of FIG. 18 taken along line XIX-XIX, and FIG. 20 is a top plan view of one base region of a pixel electrode shown in the liquid crystal display of FIG. 18.

[0148] Referring to FIG. 17, a liquid crystal display according to an exemplary embodiment of the present invention includes signal lines including a gate line **121**, a storage electrode line **125**, a step-down gate line **123**, and a data line **171**, and a pixel PX connected thereto.

[0149] The pixel PX includes first to third switching elements Qa, Qb, and Qc, first and second liquid crystal capacitors Clca and Clcb, first and second storage capacitors Csta and Cstb, and a step-down capacitor Cstd. Here, the first to third switching elements Qa, Qb, and Qc are thin film transistors, and will be denoted by the same reference numerals, respectively.

[0150] The first and second thin film transistors Qa and Qb are respectively connected to the gate line **121** and the data line **171**, and the third thin film transistor Qc is connected to the step-down gate line **123**.

[0151] The first and second thin film transistors Qa and Qb are three-terminal elements provided in the lower panel **100**, each having a control terminal connected to the gate line **121**, an input terminal connected to the data line **171**, and an output terminal connected to the first and second liquid crystal capacitors Clca and Clcb and the first and second storage capacitors Csta and Cstb.

[0152] The third thin film transistor Qc as a three-terminal element provided in the lower panel **100** has a control terminal connected to the step-down gate line **123**, an input terminal connected to the second liquid crystal capacitor Clcb, and an output terminal connected to the step-down capacitor Cstd.

[0153] The first and second liquid crystal capacitors Clca and Clcb are formed by overlapping first and second sub-pixel electrodes **191a** and **191b** connected to the first and second switching elements Qa and Qb and the common electrode **270** of the upper panel **200** to each other.

[0154] The step-down capacitor Cstd is connected to the output terminal of the third thin film transistor Qc and the storage electrode line **125**, and the storage electrode line **125** provided in the lower panel **100** and the output terminal of the third thin film transistor Qc overlap each other via an insulator.

[0155] Next, a driving method of the liquid crystal display shown in FIG. 17 will be described.

[0156] If the gate-on signal is applied to the gate line **121**, the first switching element Qa and the second switching element Qb connected thereto are turned on. Accordingly, the data voltage applied to the data line **171** is applied to the first sub-pixel electrode and the second sub-pixel electrode through the turned on first switching element Qa and second switching element Qb. At this time, the data voltages applied to the first sub-pixel electrode **191a** and the second sub-pixel electrode **191b** have the same magnitude. Accordingly, the voltages charged to the first and second liquid crystal capacitors Clca and Clcb are the same. Next, if the gate-off signal is applied to the gate line **121** and the gate-on signal is applied to the step-down gate line **123**, the first switching element Qa and the second switching element Qb are turned off and the third switching element Qc is turned on. Thus, the charge is moved from the second sub-pixel electrode **191b** to the step-down capacitor Cstd through the third switching element Qc. Thus, the charge voltage of the second liquid crystal capacitor Clcb is decreased and the step-down capacitor Cstd is charged. The charge voltage of the second liquid crystal capacitor Clcb is decreased by the capacitance of the step-down capacitor Cstd such that the charge voltage of the second liquid crystal capacitor Clcb is less than the charge voltage of the first liquid crystal capacitor Clca.

[0157] At this time, charge voltages of two liquid crystal capacitors Clca and Clcb represent different gamma curves, and the gamma curve of one pixel voltage is a combination curved line of the different gamma curves. The front combination gamma curve coincides with the reference gamma curve at the optimally-determined front side, and the lateral gamma curve approximates the front reference gamma curve. In this way, the image data are converted so that the lateral visibility is improved.

[0158] Next, the liquid crystal display shown in FIG. 17 will be described with reference to FIG. 18 and FIG. 19.

[0159] Referring to FIG. 18 and FIG. 19, the liquid crystal display according to the present exemplary embodiment includes the lower panel 100 and the upper panel 200 facing each other, a liquid crystal layer 3 interposed between the two display panels 100 and 200, and a pair of polarizers (not shown) attached at the outer surfaces of the display panels 100 and 200.

[0160] Now, the lower panel 100 will be described.

[0161] A plurality of gate conductors including a plurality of gate lines 121, a plurality of step-down gate lines 123, and a plurality of storage electrode lines 125 are formed on an insulation substrate 110.

[0162] The gate lines 121 and the step-down gate lines 123 transfer gate signals and mainly extend in a transverse direction. Each gate line 121 includes a first gate electrode 124a and a second gate electrode 124b protruding upward and downward, and each step-down gate line 123 includes a third gate electrode 124c protruding upward. The first gate electrode 124a and the second gate electrode 124b are connected to each other, thereby forming one protrusion.

[0163] The storage electrode lines 125 are extended mainly in the transverse direction, and transfer a predetermined voltage such as a common voltage Vcom. Each storage electrode line 125 includes a storage electrode (not shown) overlapping a capacitive electrode 126 and a pixel electrode 191.

[0164] A gate insulating layer 140 is formed on the gate conductors 121, 123, and 125.

[0165] A plurality of semiconductors 154a, 154b, and 154c, which may be made of hydrogenated amorphous silicon (a-Si), polysilicon, are formed on the gate insulating layer 140. The semiconductors 154a, 154b, and 154c include first and second semiconductors 154a and 154b extending toward the first and second gate electrodes 124a and 124b and connected to each other, and a third semiconductor 154c connected to the second semiconductor 154b. The third semiconductor 154c is extended, thereby forming a fourth semiconductor 157.

[0166] A plurality of ohmic contacts 164b and 167 are formed on the semiconductors 154a, 154b, and 154c, a first ohmic contact (not shown) is formed on the first semiconductor 154a, and the second ohmic contact 164b and a third ohmic contact (not shown) are respectively formed on the second semiconductor 154b and the third semiconductor 154c. The third ohmic contact is extended, thereby forming the fourth ohmic contact 167.

[0167] A data conductor including a plurality of data lines 171, a plurality of first drain electrodes 175a, a plurality of second drain electrodes 175b, and a plurality of third drain electrode 175c is formed on the ohmic contacts 164b and 167.

[0168] The data lines 171 transmit data signals and extend in the longitudinal direction thereby intersecting the gate lines 121 and the step-down gate lines 123. Each data line 171 includes a first source electrode 173a and a second source electrode 173b extending toward a first gate electrode 124a and a second gate electrode 124b.

[0169] The first drain electrode 175a, the second drain electrode 175b, and the third drain electrode 175c have one end portion having a wide area and the other end portion of a linear shape. The bar end portions of the first drain electrode 175a and the second drain electrode 175b are

partially enclosed by the first source electrode 173a and the second source electrode 173b. The wide end portion of the second drain electrode 175b is again extended, thereby forming a third source electrode 173c. An expansion 177c of the third drain electrode 175c overlaps the storage expansion 126 thereby forming a step-down capacitor Cstd, and the bar end portion is partially enclosed by the third source electrode 173c.

[0170] The first/second/third gate electrode 124a/124b/124c, the first/second/third source electrode 173a/173b/173c, and the first/second/third drain electrode 175a/175b/175c form a first/second/third thin film transistor (TFT) Qh/Ql/Qc along with the first/second/third semiconductor 154a/154b/154c, and a channel of the thin film transistor is respectively formed in the semiconductor 154a/154b/154c between the source electrode 173a/173b/173c and the drain electrode 175a/175b/175c.

[0171] The semiconductors 154a, 154b, and 154c, except for the channel region between the source electrodes 173a, 173b, and 173c and the drain electrodes 175a, 175b, and 175c, have substantially the same shape as the data conductors 171, 175a, 175b, and 175c and the underlying ohmic contacts 164b and 167. That is, the semiconductors 154a, 154b, and 154c have a portion that is exposed without being covered by the data conductors 171, 175a, 175b, and 175c, and a portion between the source electrodes 173a, 173b, and 173c and the drain electrodes 175a, 175b, and 175c.

[0172] A lower passivation layer 180p made of an inorganic insulator, such as silicon nitride or silicon oxide, is formed on the data conductors 171, 173a, 173b, 173c, 175a, 175b, and 175c and the exposed semiconductors 154a, 154b, and 154c.

[0173] A color filter 230 is formed on the lower passivation layer 180p. The color filter 230 is formed in most of the region except for where the first thin film transistor (Qh), the second thin film transistor (Ql), and the third thin film transistor (Qc) are positioned.

[0174] A light blocking member (not shown) is formed on a region that the color filter 230 does not occupy and a portion of the color filter 230. The light blocking member is referred to as a black matrix, and prevents light leakage.

[0175] An upper passivation layer 180q is formed on the color filter 230 and the light blocking member. The upper passivation layer 180q prevents peeling of the color filter 230 and the light blocking member 220, and suppresses contamination of the liquid crystal layer 3 by an organic material of the solvent that inflows from the color filter 230, so that it prevents defects such as afterimages that may occur when an image is driven.

[0176] The lower passivation layer 180p, the light blocking member, and the upper passivation layer 180q have the first contact hole 185a and the second contact hole 185b respectively exposing the wide ends of the first drain electrode 175a and the second drain electrode 175b.

[0177] A plurality of pixel electrodes 191 are formed on the upper passivation layer 180q. Each pixel electrode 191 includes a first sub-pixel electrode 191a and a second sub-pixel electrode 191b that are separated from each other with two gate lines 121 and 123 therebetween, and are disposed above and below the pixel area with the center of the gate lines 121 and 123 so as to be adjacent in a column direction. That is, one pixel area includes a first subpixel

area occupied by the first subpixel electrode **191a** and a second subpixel area occupied with by second subpixel electrode **191b**.

[0178] The shape of the first subpixel electrode **191a** and the shape of the second subpixel electrode **191b** are similar to that of the liquid crystal display according to the exemplary embodiment described with reference to FIG. 2 to FIG. 5.

[0179] Next, the upper panel **200** will be described.

[0180] The liquid crystal display according to another exemplary embodiment of the present invention may include the light blocking member and the color filter formed on the insulation substrate **210**.

[0181] Alignment layers (not shown) may be formed on inner surfaces of the display panels **100** and **200**, and they may be vertical alignment layers.

[0182] A polarizer (not shown) may be provided on the outer surface of the two display panels **100** and **200**, and transmissive axes of the two polarizers may be orthogonal to each other and any one transmissive axis of them is parallel to the gate line **121**. However, the polarizer may only be disposed at one outer surface of the two display panels **100** and **200**.

[0183] The liquid crystal layer **3** has negative dielectric anisotropy, and the liquid crystal molecules of the liquid crystal layer **3** may be aligned so that long axes thereof are vertical with respect to the surface of the two display panels **100** and **200** in a state in which there is no electric field. Therefore, the incident light may not pass through the crossed polarizers but is blocked in a state in which there is no electric field.

[0184] At least one of the liquid crystal layer **3** and the alignment layer may include a photoreactive material, which may be a reactive mesogen.

[0185] Next, a shape of the pixel electrode of the liquid crystal display according to the present exemplary embodiment will be described with reference to FIG. 20 as well as FIG. 18.

[0186] The first subpixel electrode **191a** of the liquid crystal display according to the present exemplary embodiment is similar to the basic electrode **199** shown in FIG. 4. The first subpixel electrode **191a** includes the cross-shaped stem including the first transverse stem **192a** and the first longitudinal stem **193a**, and a plurality of the first minute branches **194a** extending therefrom. The first width **W1** of the first transverse stem **192a** of the first subpixel electrode **191a** is greater than the second width **W2** of the first longitudinal stem **193a**. The first width **W1** of the first transverse stem **192a** of the first subpixel electrode **191a** may be greater than the second width **W2** of the first longitudinal stem **193a** by about 1 μm to about 3 μm . In contrast, the widths of the second transverse stem **192b** and the second longitudinal stem **193b** of the second subpixel electrode **191b** are substantially the same. That is, the width of the first transverse stem **192a** of the first subpixel electrode **191a** is greater than the width of the second transverse stem **192b** and the second longitudinal stem **193b** of the second subpixel electrode **191b** and the width of the first longitudinal stem **193a** of the first subpixel electrode **191a**.

[0187] The first transverse stem **192a** of the first subpixel electrode **191a** of the liquid crystal display according to the present exemplary embodiment may be partially disconnected. Accordingly, a portion of a plurality of cutouts defining the third minute branches **194aa** of the first subre-

gion **Da** and the portion of a plurality of cutouts defining the fifth minute branches **194cc** of the third subregion **Dc** may be connected to each other. Similarly, the portion of a plurality of cutouts defining the fourth minute branches **194bb** of the second subregion **Db** and the first cutout **92a** among a plurality of cutouts defining the sixth minute branches **194dd** of the fourth subregion **Dd** may be connected to each other. The first cutout **92a** extends in a direction parallel to the first minute branch **194a** from a portion adjacent to the edge parallel to the data line **171** among an outer edge of the first subpixel electrode **191a**, passes the first stem **192a** of the first subpixel electrode **191a**, and bends about 90 degrees, and then again extends to a portion adjacent to the edge parallel to the data line **171**. That is, the first cutout **92a** among a plurality of cutouts defining the first minute branch **194a** of the first subpixel electrode **191a** is also formed in the first stem **192a** of the first subpixel electrode **191a**.

[0188] In the first subpixel electrode **191a** of the liquid crystal display according to the present exemplary embodiment, the width of the first transverse stem **192a** in the cross-shaped stem is greater than the width of the first longitudinal stem **193a**, and the first transverse stem **192a** has the first cutout **92a** extending in parallel to the first minute branch **194a** such that the brightness of the region corresponding to the first subpixel electrode **191a** may be reduced. Accordingly, in the low gray scale region, the brightness of the entire pixel may be reduced. Therefore, the luminance of the liquid crystal display may be decreased in the low gray scale region, and thereby the correct gray scale expression is possible in the low gray scale region.

[0189] The number of liquid crystal molecules **31** slanted in the direction parallel to the first transverse stem **192a** of the first subpixel electrode **191a** is greater than the number of liquid crystal molecules **31** slanted in the direction parallel to the first longitudinal stem **193a** such that the luminance of the region occupied by the first subpixel electrode **191a** is reduced simultaneously, and when viewing the liquid crystal display from the left side and the right side, the short axis of the liquid crystal molecules **31** is reorganized more than the long axis such that deterioration in the display quality, such as a stripe, may be prevented compared to a case in which the long axis of the liquid crystal molecule **31** is reorganized more than the short axis.

[0190] Many features of the liquid crystal display according to the exemplary embodiment described with reference to FIG. 2 to FIG. 5 may be applied to the liquid crystal display according to the current exemplary embodiment.

[0191] Next, a liquid crystal display according to another exemplary embodiment of the present invention will be described with reference to FIG. 21 and FIG. 22. FIG. 21 is a layout view of the liquid crystal display according to another exemplary embodiment of the present invention, and FIG. 22 is a top plan view of one base region of a pixel electrode shown in the liquid crystal display of FIG. 21.

[0192] Referring to FIG. 21 and FIG. 22, the liquid crystal display according to the present exemplary embodiment is similar to the liquid crystal display according to the exemplary embodiment of FIG. 17 to FIG. 20. The description of the same constituent elements is omitted.

[0193] In the liquid crystal display according to the present exemplary embodiment, as opposed to the liquid crystal display according to the exemplary embodiment shown in FIG. 17 to FIG. 20, the common electrode **270** has the

second cutout **271a** formed at the position corresponding to the first longitudinal stem **193a** of the first subpixel electrode **191a**. The width of the second cutout **271a** may be in a range of about 2 μm to about 8 μm .

[0194] According to the liquid crystal display according to another exemplary embodiment of the present invention, the common electrode **270** may further include an additional cutout (not shown) formed at the position corresponding to the second longitudinal stem **193b** of the second subpixel electrode **191b**. According to the liquid crystal display according to another exemplary embodiment of the present invention, the common electrode **270** may further include an additional cutout (not shown) formed at the position corresponding to the second transverse stem **192b** of the second subpixel electrode **191b**.

[0195] In this way, in liquid crystal display of the present exemplary embodiment, the width of the first transverse stem **192a** of the first subpixel electrode **191a** is greater than the width of the first longitudinal stem **193a**, the first transverse stem **192a** has the first cutout **92a** parallel to the first minute branch **194a**, and the common electrode **270** of the upper panel **200** has the second cutout **271a** formed at the position corresponding to the first longitudinal stem **193a** of the first subpixel electrode **191a**. Accordingly, the transmittance of the light of the first longitudinal stem **193a** of the first subpixel electrode **191a** is higher than the transmittance of the light of the first transverse stem **192a** of the first subpixel electrode **191a**. That is, similar to the liquid crystal display according to the exemplary embodiment shown in FIG. 17 to FIG. 20, by reducing the transmittance of the first transverse stem **192a** of the first subpixel electrode **191a**, the entire luminance of the liquid crystal display is reduced in the low gray scale region such that the correct gray scale expression is possible in the low gray scale region, and the lateral visibility may be close to the front visibility.

[0196] Many features of the liquid crystal display according to the exemplary embodiment described with reference to FIG. 17 to FIG. 20 may be applied to the liquid crystal display according to the current exemplary embodiment.

[0197] Next, a liquid crystal display according to another exemplary embodiment of the present invention will be described with reference to FIG. 23 and FIG. 24. FIG. 23 is a layout view of the liquid crystal display according to another exemplary embodiment of the present invention, and FIG. 24 is a top plan view of one base region of a pixel electrode shown in the liquid crystal display of FIG. 23.

[0198] Referring to FIG. 23 and FIG. 24, the liquid crystal display according to the present exemplary embodiment is similar to the liquid crystal display according to the exemplary embodiment of FIG. 17 to FIG. 20. The description of the same constituent elements is omitted.

[0199] In the liquid crystal display according to the present exemplary embodiment, as opposed to the liquid crystal display shown in FIG. 17 to FIG. 20, the width of the second transverse stem **192b** of the second subpixel electrode **191b** is greater than the width of the second longitudinal stem **193b** of the second subpixel electrode **191b**. The width of the first transverse stem **192a** of the first subpixel electrode **191a** may be greater than the width of the first longitudinal stem **193a** by about 1 μm to about 3 μm , and the width of the second transverse stem **192b** of the second subpixel electrode **191b** may be greater than the width of the second longitudinal stem **193b** by about 1 μm to about 3 μm . The

first transverse stem **192a** of the first subpixel electrode **191a** may not include the first cutout **92a**. That is, the first transverse stem **192a** of the first subpixel electrode **191a** may be continuously formed.

[0200] Accordingly, the first subpixel electrode **191a** of the liquid crystal display according to the present exemplary embodiment may include the cross-shaped stem including the first transverse stem **192a** and the first longitudinal stem **193a**, and a plurality of the first minute branches **194a** extending therefrom, and the second subpixel electrode **191b** may include the cross-shaped stem including the second transverse stem **192b** and the second longitudinal stem **193b**, and a plurality of the second minute branches **194b** extending therefrom.

[0201] The width of the first transverse stem **192a** of the first subpixel electrode **191a** is greater than the width of the first longitudinal stem **193a**, and the width of the second transverse stem **192b** of the second subpixel electrode **191b** is greater than the width of the second longitudinal stem **193b**.

[0202] In the cross-shaped stems of the first subpixel electrode **191a** of the liquid crystal display according to the present exemplary embodiment, the width of the first transverse stem **192a** is greater than the width of the first longitudinal stem **193a** such that the brightness of the region corresponding to the first subpixel electrode **191a** may be reduced. Accordingly, in the low gray scale region, the brightness of the entire pixel may be reduced. Therefore, the luminance of the liquid crystal display may be reduced in the low gray region such that the correct gray expression is possible in the low gray region. In the cross-shaped stem of the second subpixel electrode **191b**, the width of the second transverse stem **192b** is greater than the second longitudinal stem **193b** to reduce the luminance of the liquid crystal display in the high gray region such that the deterioration of the display quality generated according to the increasing of the luminance in the high gray scale region may be prevented.

[0203] In the liquid crystal display according to an exemplary embodiment of the present invention, the pixel electrode disposed in one pixel area is divided into the first subpixel electrode **191a** and the second subpixel electrode **191b**, the first subpixel electrode **191a** and the second subpixel electrode **191b** may include the cross-shaped stem and a plurality of minute branches extended therefrom, the width of the first transverse stem **192a** of the first subpixel electrode **191a** is greater than the width of the first longitudinal stem **193a** of the first subpixel electrode **191a**, and the width of the second transverse stem **192b** of the second subpixel electrode **191b** is greater than the width of the second longitudinal stem **193b** of the second subpixel electrode **191b** such that the luminance of the liquid crystal display may be reduced in the low gray scale region and the high gray scale region, and as a result, the correct gray scale expression is possible in the low gray scale region and the high gray scale region, and the lateral visibility may be closer to the front visibility. When viewing the liquid crystal display from the side, the short axis of the liquid crystal molecules **31** may be reorganized more than the long axis, thereby preventing deterioration in the quality, such as the stripe shape, which may be generated in the case of the reorganization of the long axis of the liquid crystal molecules **31**.

[0204] Many features of the liquid crystal display according to the exemplary embodiment described with reference to FIG. 2 to FIG. 5, and the liquid crystal display according to the exemplary embodiment described with reference to FIG. 17 to FIG. 20 may be applied to the liquid crystal display according to the current exemplary embodiment.

[0205] Next, a liquid crystal display according to another exemplary embodiment of the present invention will be described with reference to FIG. 25 and FIG. 26. FIG. 25 is a layout view of the liquid crystal display according to another exemplary embodiment of the present invention, and FIG. 26 is a top plan view of one base region of a field generating electrode shown in the liquid crystal display of FIG. 25.

[0206] Referring to FIG. 25 and FIG. 26, the liquid crystal display according to the present exemplary embodiment is similar to the liquid crystal display according to the exemplary embodiment of FIG. 17 to FIG. 20, and the liquid crystal display according to the exemplary embodiment of FIG. 23 and FIG. 24. The description of the same constituent elements is omitted.

[0207] However, in the liquid crystal display according to the present exemplary embodiment, differently from the liquid crystal display shown in FIG. 2 to FIG. 5 and the liquid crystal display shown in FIG. 17 to FIG. 20, the width of the second longitudinal stem 193b of the second subpixel electrode 191b is greater than the width of the second transverse stem 192b of the second subpixel electrode 191b. As opposed to the liquid crystal display according to the exemplary embodiment shown in FIG. 17 to FIG. 20, the first cutout 92a is not formed in the first transverse stem 192a of the first subpixel electrode 191a. That is, the first transverse stem 192a of the first subpixel electrode 191a may be continuously formed.

[0208] Accordingly, the first subpixel electrode 191a of the liquid crystal display according to the present exemplary embodiment may include the cross-shaped stem having the first transverse stem 192a and the first longitudinal stem 193a, and a plurality of the first minute branches 194a extending therefrom, and the second subpixel electrode 191b may include the cross-shaped stem of the second transverse stem 192b and the second longitudinal stem 193b, and a plurality of the second minute branches 194b extending therefrom.

[0209] The width of the first transverse stem 192a of the first subpixel electrode 191a is greater than the width of the first longitudinal stem 193a, and the width of the second longitudinal stem 193b of the second subpixel electrode 191b is greater than the width of the second transverse stem 192b of the second subpixel electrode 191b.

[0210] In the cross-shaped stems of the first subpixel electrode 191a of the liquid crystal display according to the present exemplary embodiment, the width of the first transverse stem 192a is greater than the width of the first longitudinal stem 193a such that the brightness of the region corresponding to the first subpixel electrode 191a may be reduced. Accordingly, in the low gray scale region, the brightness of the entire pixel may be reduced. Therefore, the luminance of the liquid crystal display may be reduced in the low gray scale region such that the correct gray scale expression is possible in the low gray scale region. The width of the second longitudinal stem 193b is greater than the width of the second transverse stem 192b of the second subpixel electrode 191b to reduce the luminance of the

liquid crystal display in the high gray scale region such that the deterioration of the display quality generated according to the increasing of the luminance in the high gray scale region may be prevented.

[0211] Many features of the liquid crystal display according to the exemplary embodiment described with reference to FIG. 2 to FIG. 5 and the liquid crystal display according to the exemplary embodiment described with reference to FIG. 17 to FIG. 20 may be applied to the liquid crystal display according to the current exemplary embodiment.

[0212] Next, a liquid crystal display according to another exemplary embodiment of the present invention will be described with reference to FIG. 27 and FIG. 28. FIG. 27 is a layout view of the liquid crystal display according to another exemplary embodiment of the present invention, and FIG. 28 is a top plan view of one base region of a field generating electrode shown in the liquid crystal display of FIG. 27.

[0213] Referring to FIG. 27 and FIG. 28, the liquid crystal display according to the present exemplary embodiment is similar to the liquid crystal display according to the exemplary embodiment shown in FIG. 17 to FIG. 20 and the liquid crystal display according to the exemplary embodiment shown in FIG. 21 and FIG. 22. The description of the same constituent elements is omitted.

[0214] However, in the liquid crystal display according to the present exemplary embodiment, as opposed to the liquid crystal displays according to the described exemplary embodiments, the width of the first transverse stem 192a of the first subpixel electrode 191a is not only greater than the width of the first longitudinal stem 193a, but the width of the second transverse stem 192b of the second subpixel electrode 191b is also greater than the width of the second longitudinal stem 193b. The width of the first transverse stem 192a of the first subpixel electrode 191a may be greater than the width of the first longitudinal stem 193a by about 1 μm to about 3 μm , and the width of the second transverse stem 192b of the second subpixel electrode 191b may be greater than the width of the second longitudinal stem 193b by about 1 μm to about 3 μm . The common electrode 270 of the upper panel 200 may have the second cutout 271a formed at the position corresponding to the first longitudinal stem 193a of the first subpixel electrode 191a and the third cutout 271b formed at the position corresponding to the second longitudinal stem 193b of the second subpixel electrode 191b. The width of the second cutout 271a and the third cutout 271b may be in a range of about 2 μm to about 8 μm . However, according to the liquid crystal display according to another exemplary embodiment of the present invention, the third cutout 271b of the common electrode 270 may be omitted. According to the liquid crystal display according to another exemplary embodiment of the present invention, the third cutout 271b of the common electrode 270 is not formed at the position corresponding to the second longitudinal stem 193b of the second subpixel electrode 191b, and may be formed at the position corresponding to the second transverse stem 192b of the second subpixel electrode 191b.

[0215] In this way, in the case of the liquid crystal display according to the present exemplary embodiment, the width of the first transverse stem 192a of the first subpixel electrode 191a is greater than the width of the first longitudinal stem 193a, and the common electrode 270 of the upper panel 200 has the second cutout 271a formed at the position

corresponding to the first longitudinal stem **193a** of the first subpixel electrode **191a**. Accordingly, the transmittance of the light of the first longitudinal stem **193a** of the first subpixel electrode **191a** is higher than the transmittance of the light of the first transverse stem **192a** of the first subpixel electrode **191a**. That is, similar to the liquid crystal display according to the exemplary embodiment shown in FIG. 2 to FIG. 5, by reducing the transmittance of the first transverse stem **192a** of the first subpixel electrode **191a**, the entire luminance of the liquid crystal display may be reduced in the low gray scale region such that the correct gray scale expression is possible in the low gray scale region, and the lateral visibility may be close to the front visibility.

[0216] In the case of the liquid crystal display according to the present exemplary embodiment, the width of the second transverse stem **192b** of the second subpixel electrode **191b** is greater than the width of the second longitudinal stem **193b**, and the common electrode **270** has the third cutout **271b** formed at the position corresponding to the second longitudinal stem **193b** of the second subpixel electrode **191b**. Accordingly, the transmittance of the light for the second transverse stem **192b** of the second subpixel electrode **191b** is higher than the transmittance of the light for the second longitudinal stem **193b** of the second subpixel electrode **191b**. However, as described above, according to the liquid crystal display according to another exemplary embodiment of the present invention, the third cutout **271b** of the common electrode **270** may be omitted. According to the liquid crystal display according to another exemplary embodiment of the present invention, the third cutout **271b** of the common electrode **270** is not formed at the position corresponding to the second longitudinal stem **193b** of the second subpixel electrode **191b** and may be formed at the position corresponding to the second transverse stem **192b** of the second subpixel electrode **191b**. Therefore, the luminance of the liquid crystal display may be reduced in the high gray scale region such that the deterioration of the display quality generated according to the increasing of the luminance may be prevented in the high gray scale region.

[0217] As described above, according to the liquid crystal display according to another exemplary embodiment of the present invention, the third cutout **271b** of the common electrode **270** may be omitted. According to the liquid crystal display according to another exemplary embodiment of the present invention, the third cutout **271b** of the common electrode **270** is not formed at the position corresponding to the second longitudinal stem **193b** of the second subpixel electrode **191b**, and may be formed at the position corresponding to the second transverse stem **192b** of the second subpixel electrode **191b**.

[0218] Many features of the liquid crystal display according to the present exemplary embodiment are similar to those of the liquid crystal display according to the exemplary embodiment of FIG. 2 to FIG. 5, the liquid crystal display according to the exemplary embodiment of FIG. 17 to FIG. 20, and the liquid crystal display according to the exemplary embodiment of FIG. 21 and FIG. 22, so they may be applied to the liquid crystal display of the present exemplary embodiment.

[0219] The second cutout **271a** and the third cutout **271b** in the above exemplary embodiments may be replaced with a protrusion formed on or under the common electrode **270**. That is, the common electrode **270** may not include the second cutout **271a** and the third cutout **271b**, and the upper

panel **200** may include an insulating protrusion formed at the position corresponding to the second cutout **271a** and the third cutout **271b** on or under the common electrode **270**.

[0220] It will be apparent to those skilled in the art that various modifications and variations can be made in the present invention without departing from the spirit or scope of the invention. Thus, it is intended that the present invention cover various modifications and variations of this invention provided they come within the spirit and scope of the appended claims and their equivalents.

What is claimed is:

1. A liquid crystal display comprising
 - a first substrate;
 - a gate line and a data line disposed on the first substrate; and
 - a pixel electrode connected to the gate line and the data line and comprising a first sub pixel electrode and a second sub pixel electrode disposed on the first substrate,
 each of the first sub pixel electrode and the second sub pixel electrode comprising:
 - a transverse stem;
 - a longitudinal stem; and
 - a plurality of minute branches extending from transverse stem and the longitudinal stem,
 wherein a width of the first sub pixel electrode is different from a width of the second sub pixel electrode.
2. The liquid crystal display of claim 1, wherein the transverse stem comprises a plurality of first cutouts parallel to the minute branches.
3. The liquid crystal display of claim 2, further comprising:
 - a second substrate facing the first substrate;
 - a liquid crystal layer comprising liquid crystal molecules disposed between the first substrate and the second substrate;
 - a common electrode disposed between the liquid crystal layer and the second substrate; and
 - an alignment layer disposed on at least one of the first substrate and the second substrate,
 wherein:
 - the liquid crystal molecules are arranged substantially perpendicular to a surface of the first substrate and the second substrate in the absence of an electric field between the pixel electrode and the common electrode; and
 - at least one of the liquid crystal layer and the alignment layer comprises a light reactive material.
4. The liquid crystal display of claim 3, wherein the common electrode comprises a second cutout formed at a position corresponding to the longitudinal stem.
5. The liquid crystal display of claim 1, further comprising:
 - a second substrate facing the first substrate;
 - a liquid crystal layer comprising liquid crystal molecules disposed between the first substrate and the second substrate;
 - a common electrode disposed between the liquid crystal layer and the second substrate; and
 - an alignment layer disposed on at least one of the first substrate and the second substrate,
 wherein:
 - the liquid crystal molecules are arranged substantially perpendicular to a surface of the first substrate and the

second substrate in the absence of an electric field between the pixel electrode and the common electrode;
and
at least one of the liquid crystal layer and the alignment layer comprises a light reactive material.

6. The liquid crystal display of claim 5, wherein the common electrode comprises a second cutout formed at a position corresponding to the longitudinal stem.

7. The liquid crystal display of claim 1, wherein the common electrode comprises a second cutout formed at a position corresponding to the longitudinal stem.

* * * * *

专利名称(译)	液晶显示器包括像素电极，该像素电极具有横向杆，纵向杆和多个微小分支		
公开(公告)号	US20170248826A1	公开(公告)日	2017-08-31
申请号	US15/592578	申请日	2017-05-11
[标]申请(专利权)人(译)	三星显示有限公司		
申请(专利权)人(译)	三星DISPLAY CO. , LTD.		
当前申请(专利权)人(译)	三星DISPLAY CO. , LTD.		
[标]发明人	CHANG HAK SUN RYU JANG WI SHIN KI CHUL JANG JAE SOO		
发明人	CHANG, HAK SUN RYU, JANG WI SHIN, KI CHUL JANG, JAE-SOO		
IPC分类号	G02F1/1343 G02F1/1362 G02F1/1337		
CPC分类号	G02F1/134309 G02F1/133753 G02F1/136286 G02F2201/123 G02F2001/133757 G02F2001/134345 G02F2201/121 G02F2001/133742 G02F1/139 G02F1/133553 G02F1/1337		
优先权	1020120086332 2012-08-07 KR		
其他公开文献	US10520777		
外部链接	Espacenet USPTO		

摘要(译)

一种液晶显示器，包括第一基板；栅极线和数据线设置在第一基板上；像素电极连接到栅极线和数据线，并包括设置在第一基板上的第一子像素电极和第二子像素电极。第一子像素电极和第二子像素电极中的每一个包括横向杆；纵向茎；以及从横向杆和纵向杆延伸的多个微小分支。第一子像素电极的宽度不同于第二子像素电极的宽度。

