



US 20160097947A1

(19) **United States**
(12) **Patent Application Publication**
TOMIOKA et al.

(10) **Pub. No.: US 2016/0097947 A1**
(43) **Pub. Date: Apr. 7, 2016**

(54) **LIQUID CRYSTAL DISPLAY DEVICE**

Publication Classification

(71) Applicant: **Japan Display Inc.**, Tokyo (JP)
(72) Inventors: **Yasushi TOMIOKA**, Hitachinaka-shi (JP); **Noboru KUNIMATSU**, Chiba-shi (JP); **Yosuke HYODO**, Chiba-shi (JP); **Toshiki KANEKO**, Chiba-shi (JP); **Yuko MATSUMOTO**, Onjuku-machi (JP)

(51) **Int. Cl.**
G02F 1/1339 (2006.01)
G02F 1/1362 (2006.01)
G02F 1/1368 (2006.01)
(52) **U.S. Cl.**
CPC *G02F 1/13394* (2013.01); *G02F 1/1368* (2013.01); *G02F 1/136286* (2013.01); *G02F 2001/13396* (2013.01)

(21) Appl. No.: **14/968,042**

(22) Filed: **Dec. 14, 2015**

Related U.S. Application Data

(63) Continuation of application No. 13/719,285, filed on Dec. 19, 2012, now Pat. No. 9,250,479.

Foreign Application Priority Data

Dec. 19, 2011 (JP) 2011-277234

(57) **ABSTRACT**

A liquid crystal display device includes: a TFT substrate having gate lines and data lines arranged thereon, the gate lines extending in a first direction and arranged in a second direction, the data lines extending in the second direction and arranged in the first direction; a counter substrate having a black matrix and a color filter; and liquid crystals put between the TFT substrate and the counter substrate. Columnar spacers are formed on the counter substrate, the portions corresponding to the columnar spacers. A convex portion and a concave portion are present at the top end of the columnar spacer. The pedestal is formed corresponding to the concave portion. The concave portion is opened at the ends thereof and connected to the lateral side of the columnar spacer.

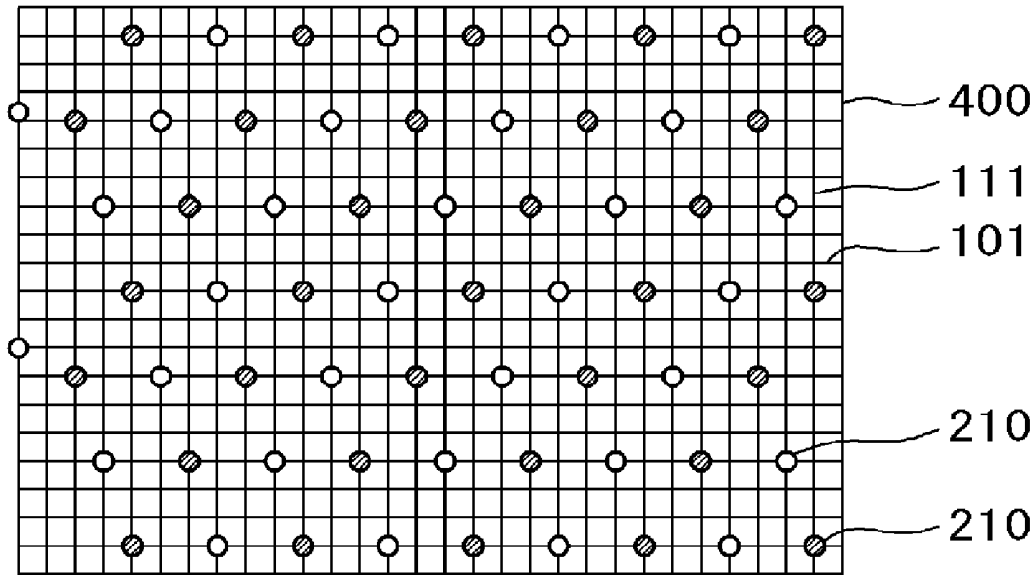

FIG. 1

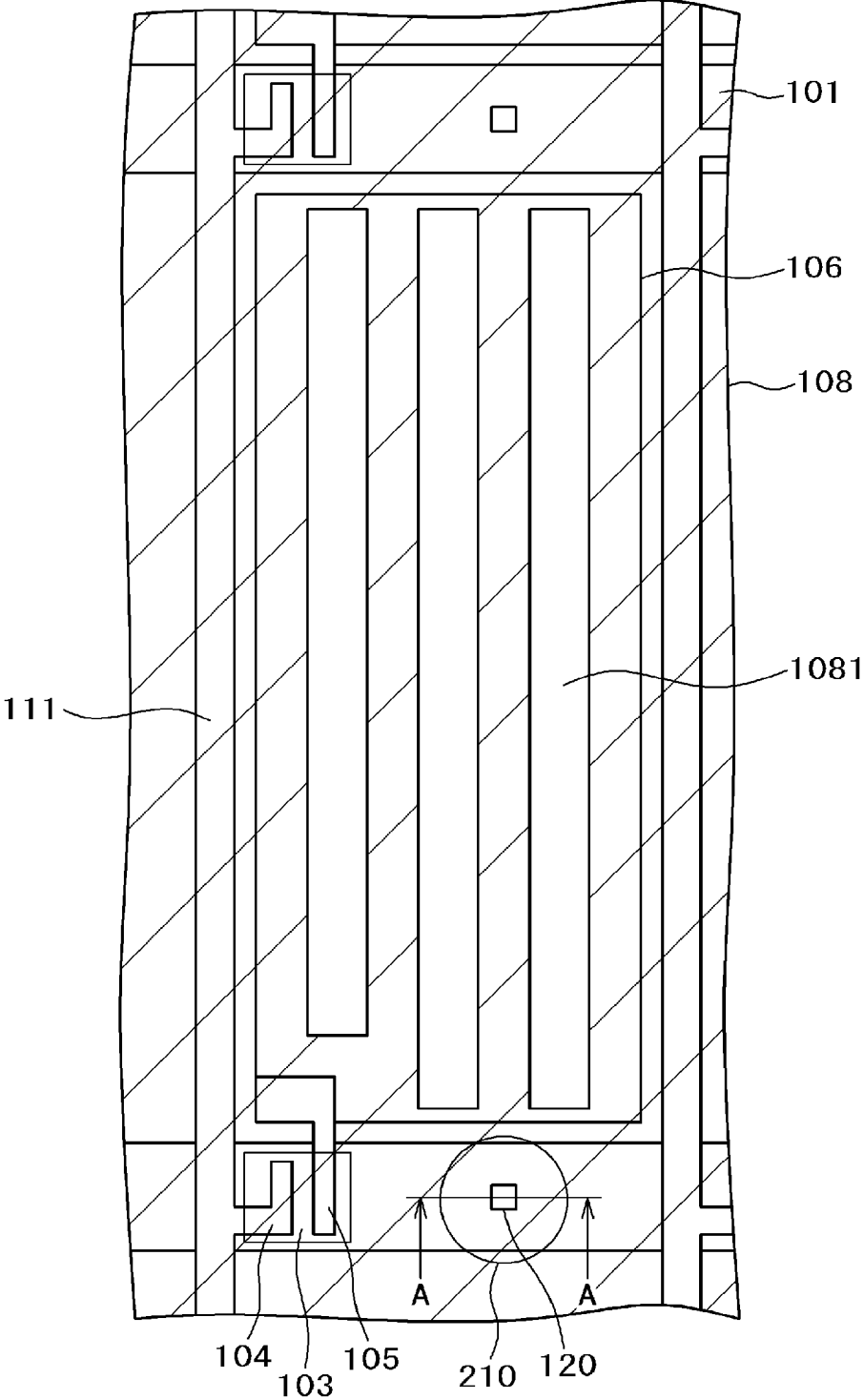

FIG. 2

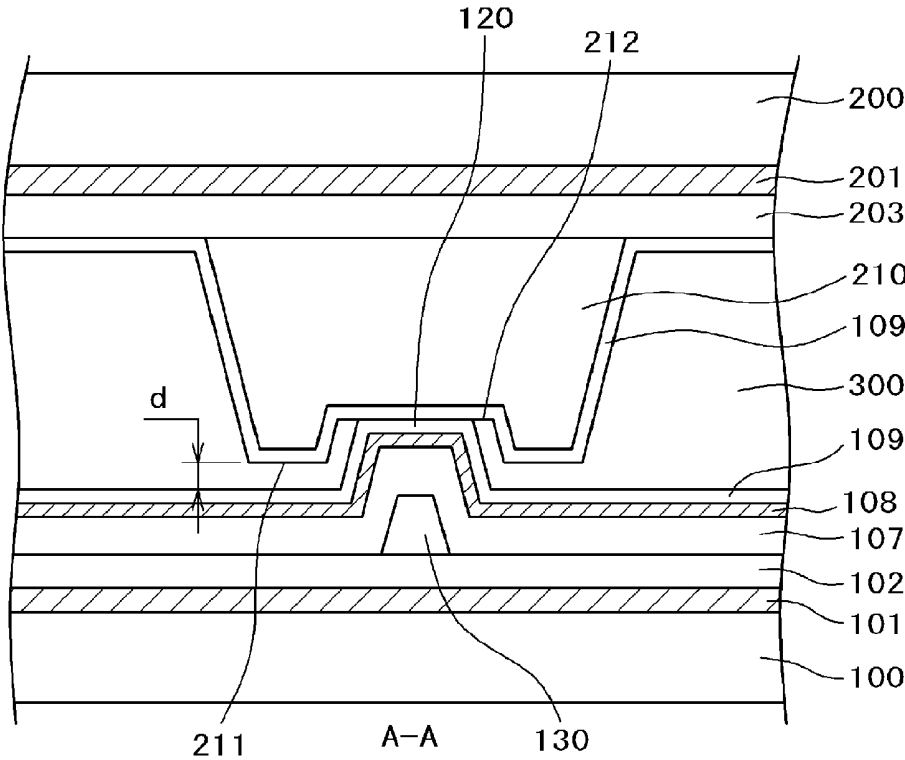

FIG. 3

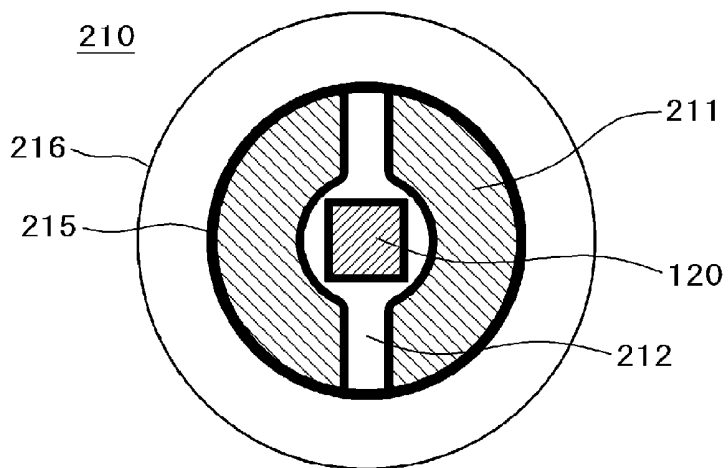

FIG. 4

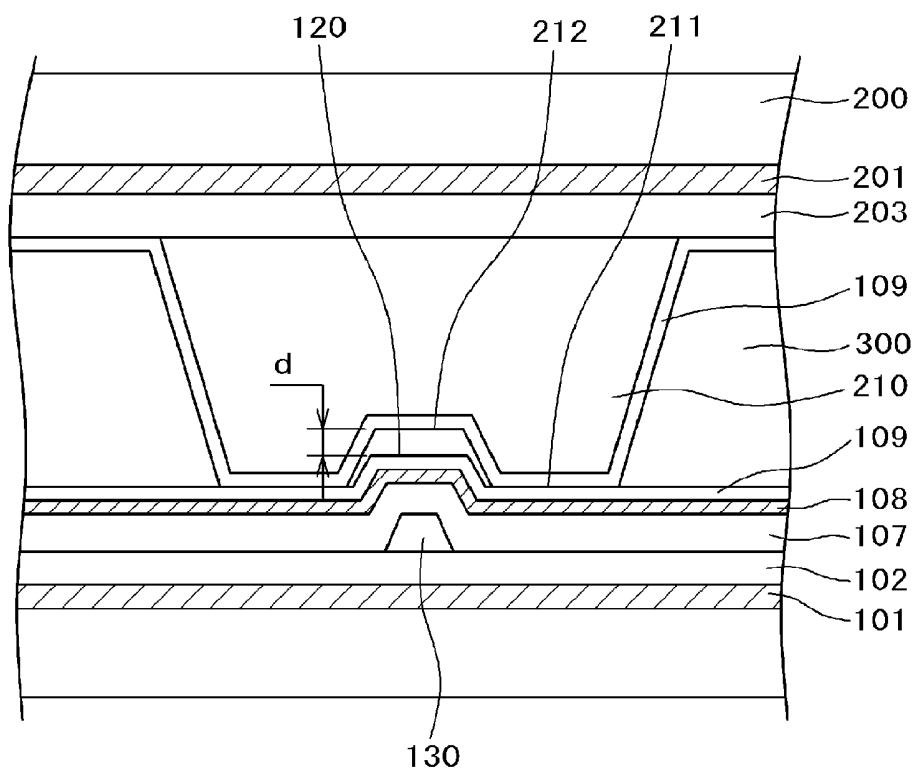

FIG. 5

210

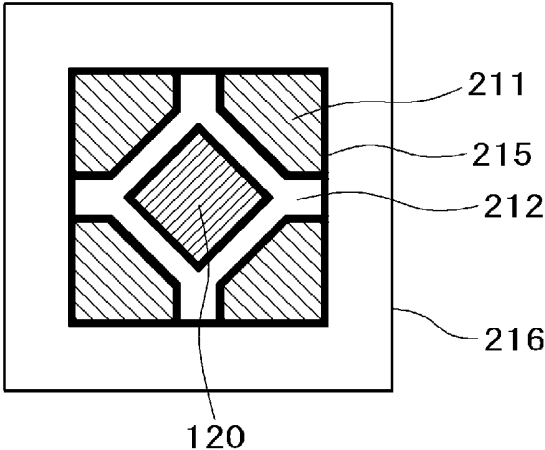

FIG. 6

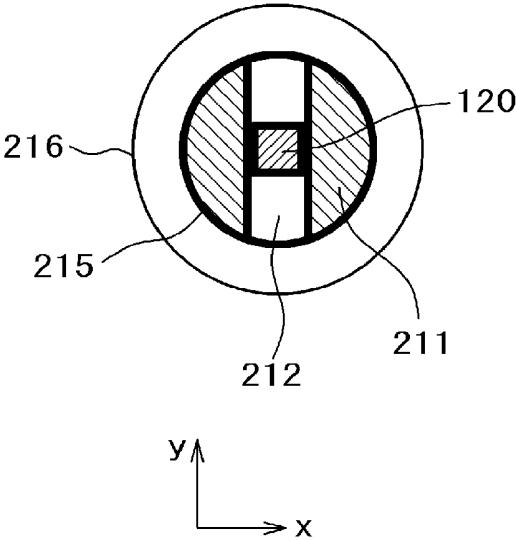

FIG. 7

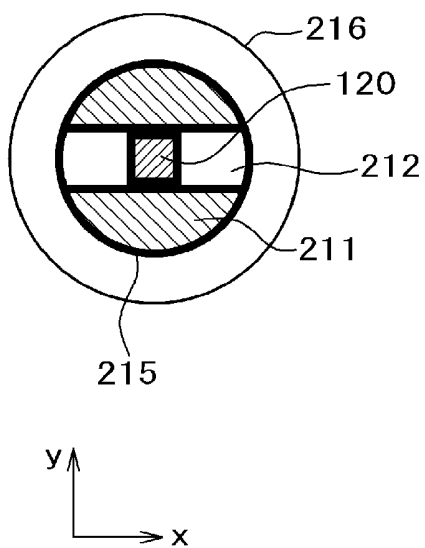

FIG. 8

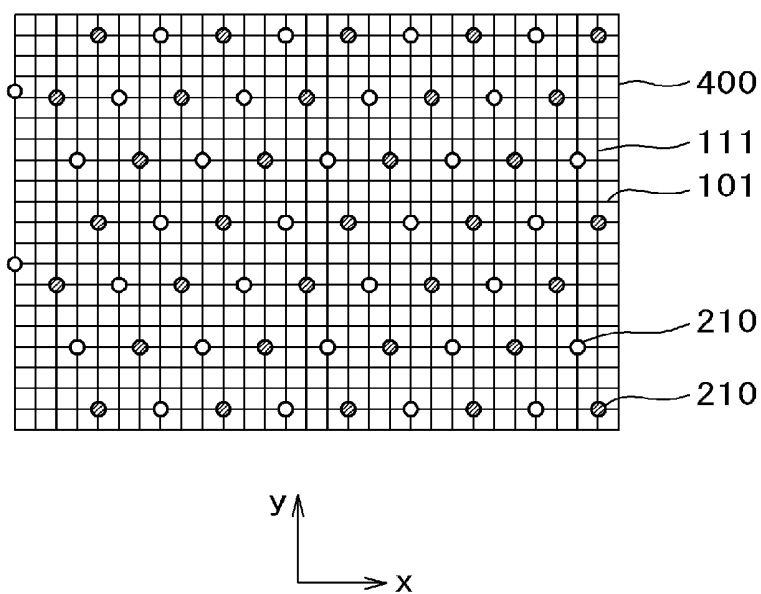

FIG. 9A

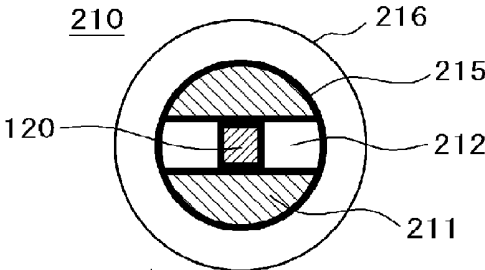

FIG. 9C

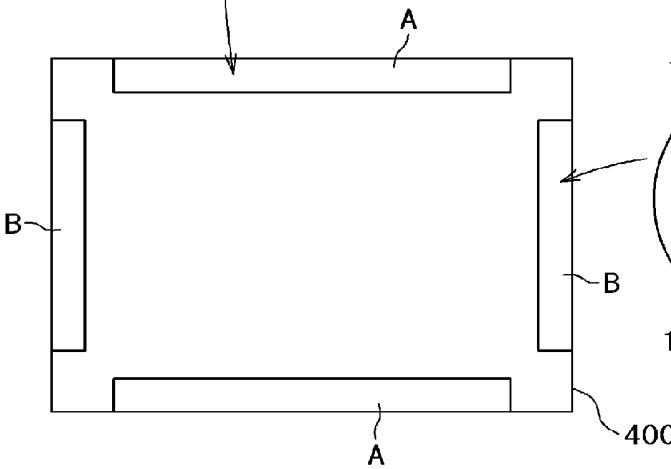

FIG. 9B

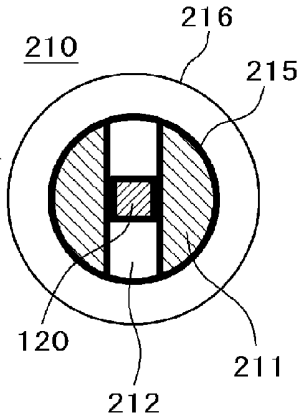

FIG. 10

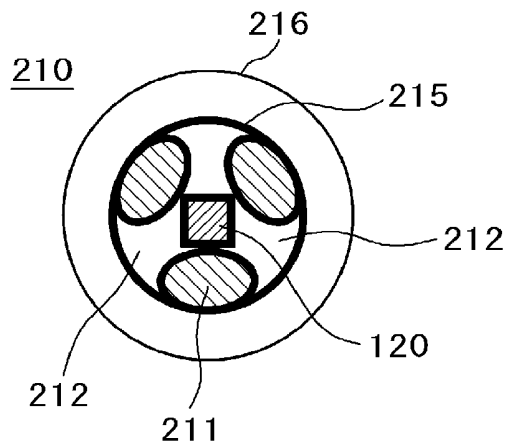

FIG. 11

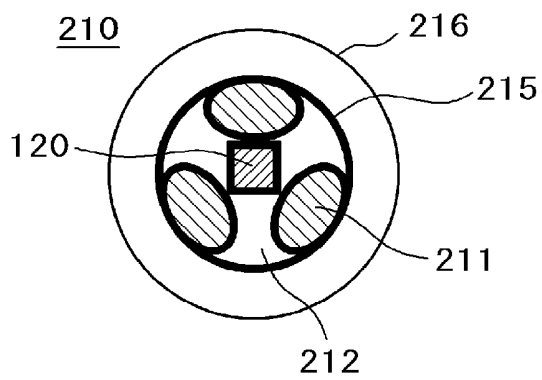

FIG. 12

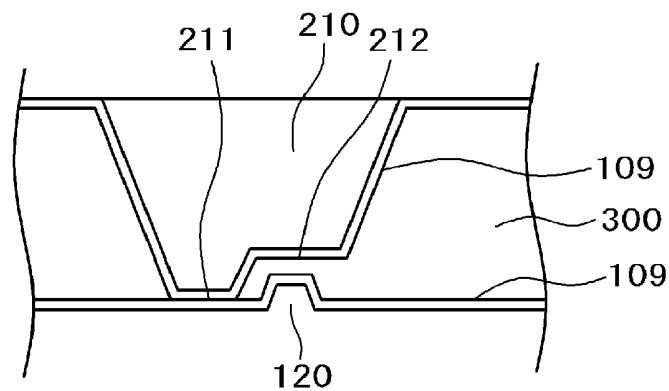

FIG. 13

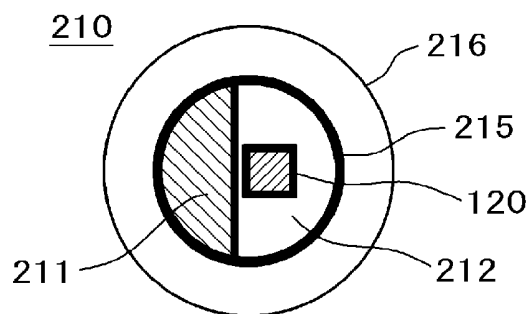

FIG. 14

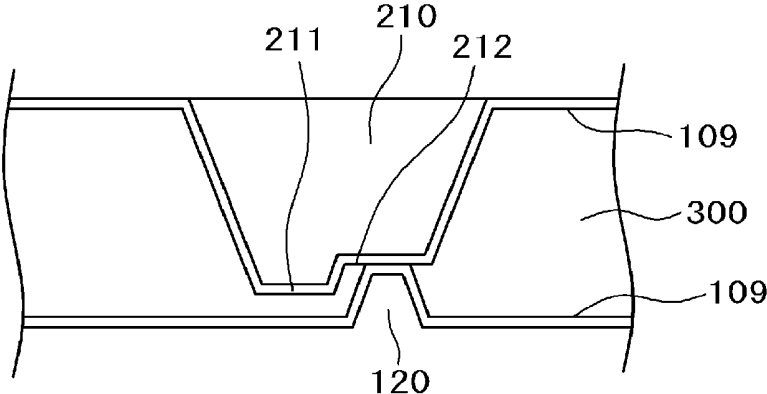

FIG. 15

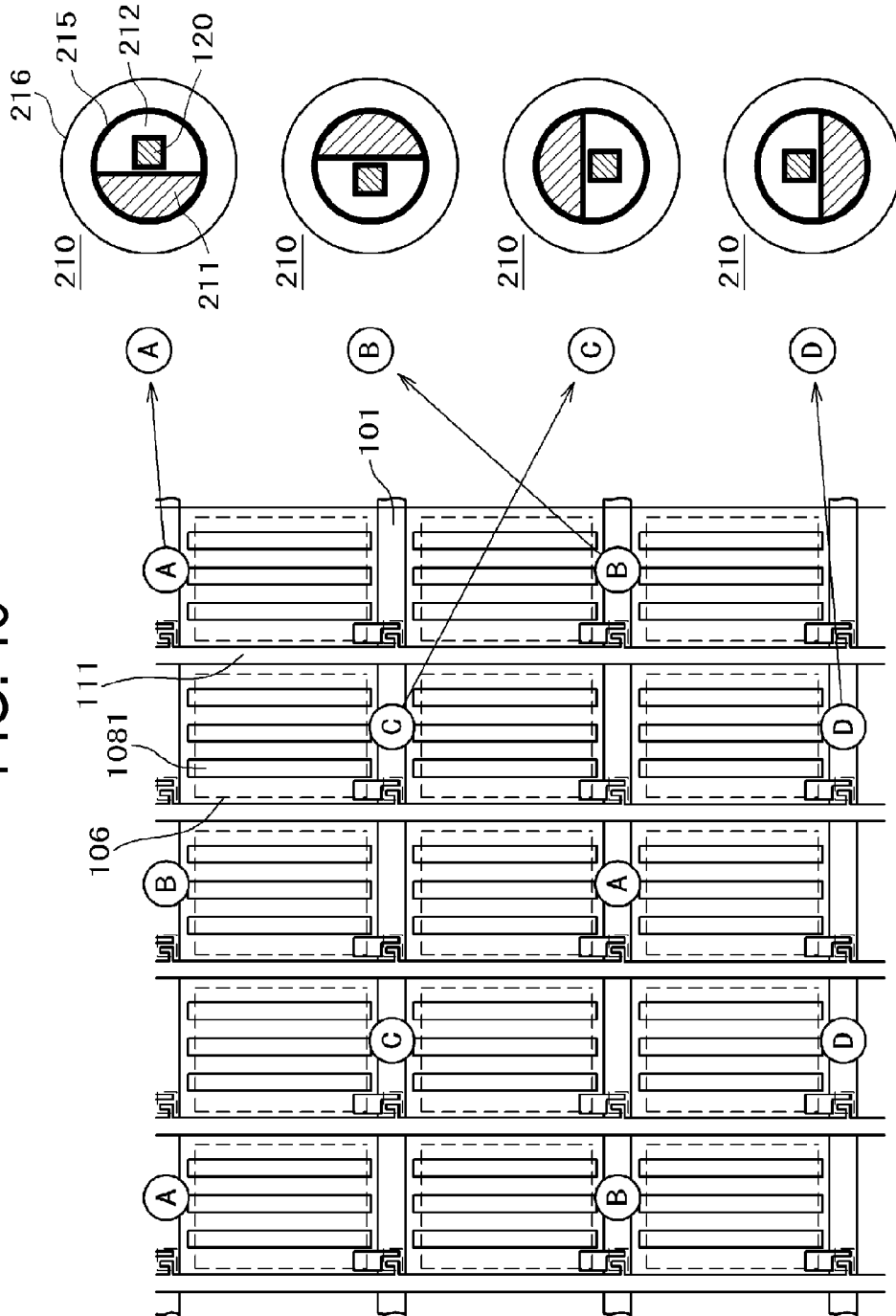

FIG. 16

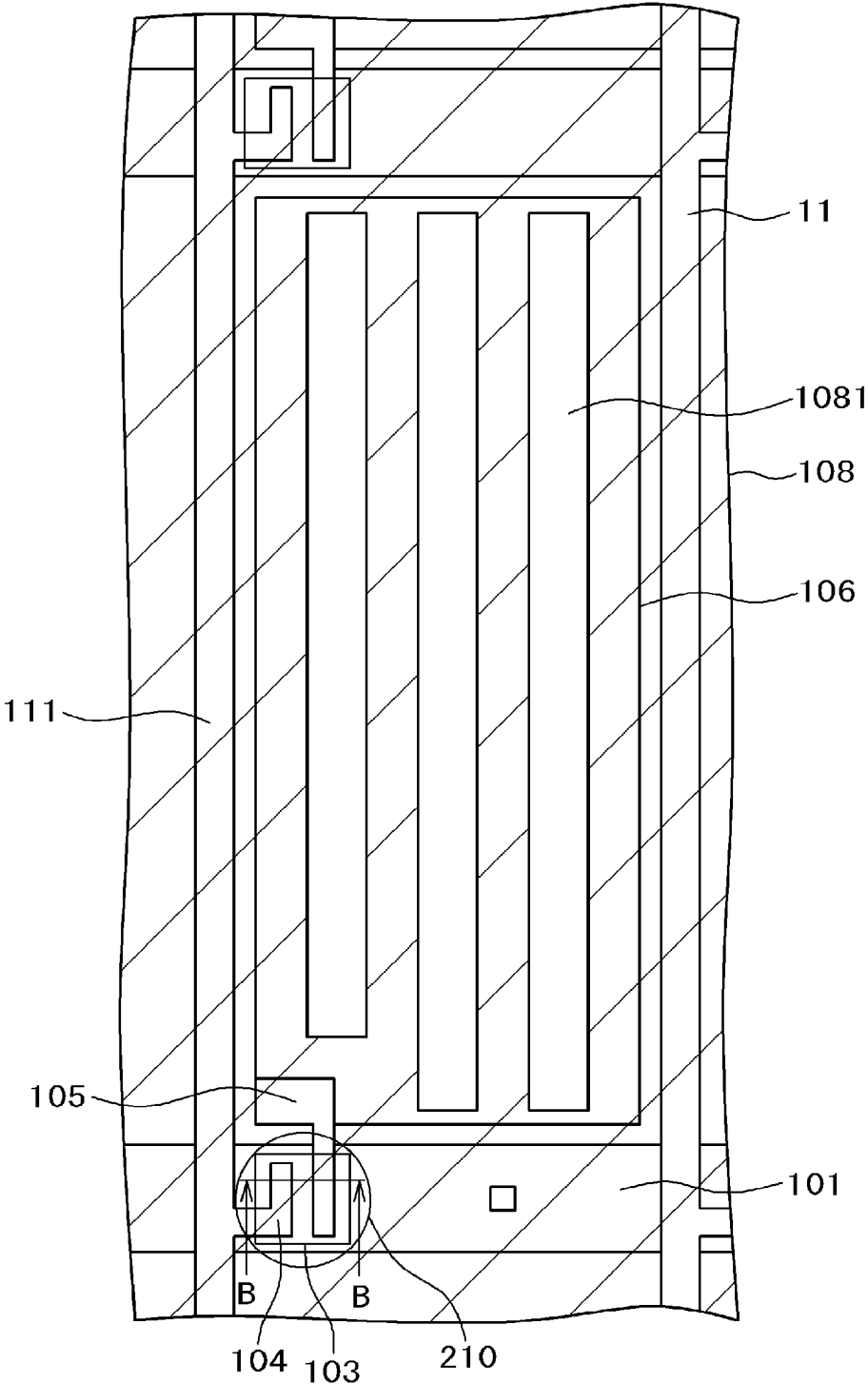

FIG. 17

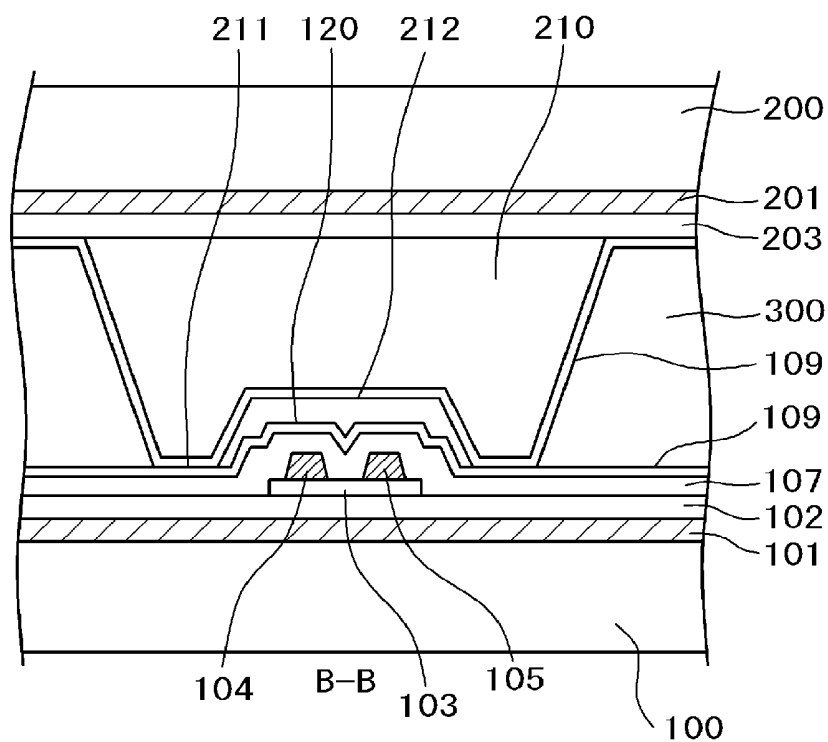

FIG. 18

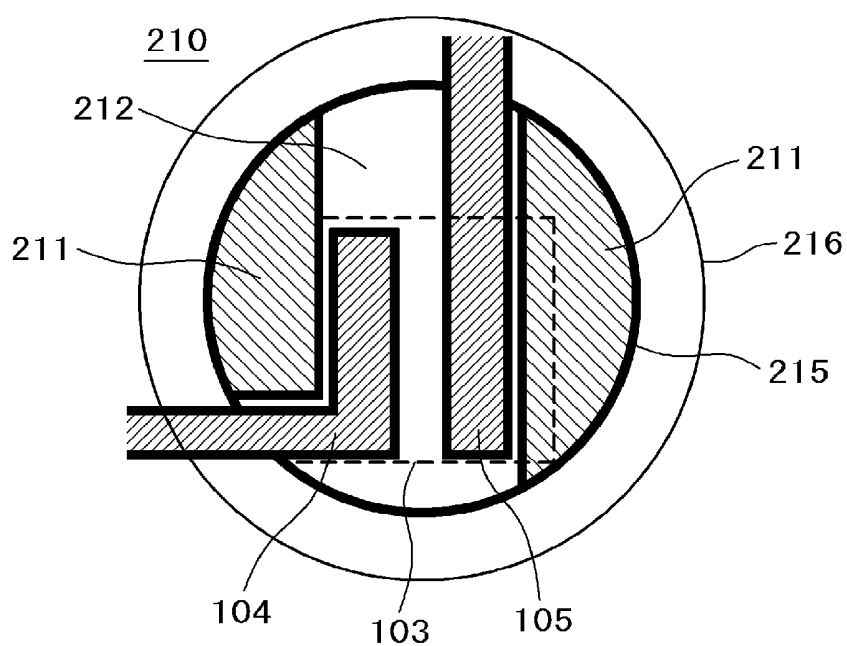

FIG. 19A

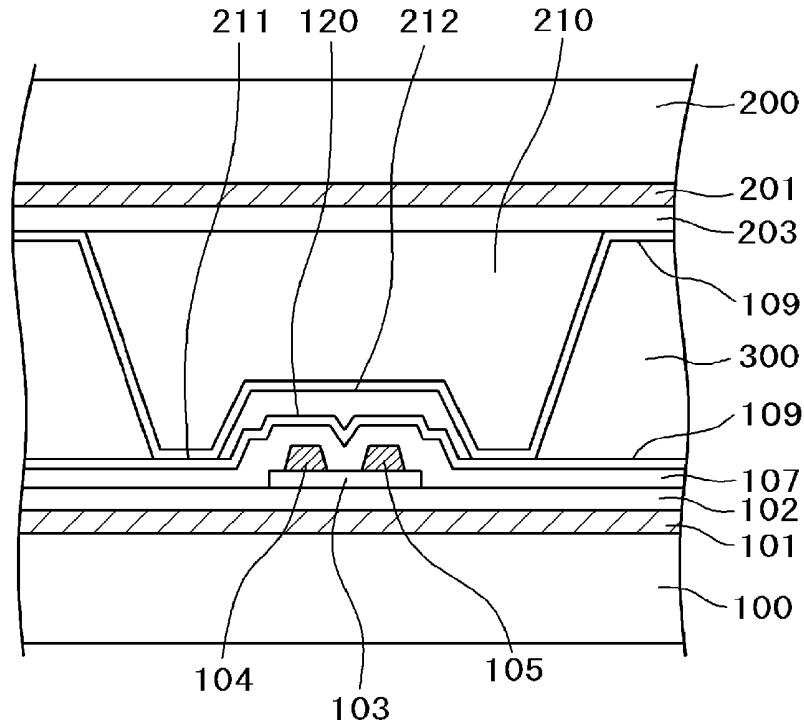

FIG. 19B

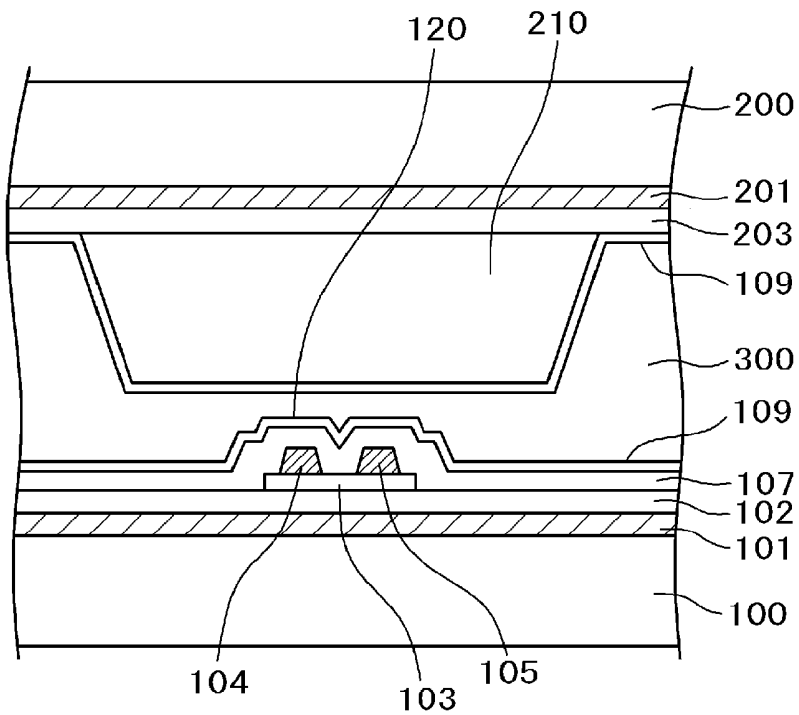

FIG. 20

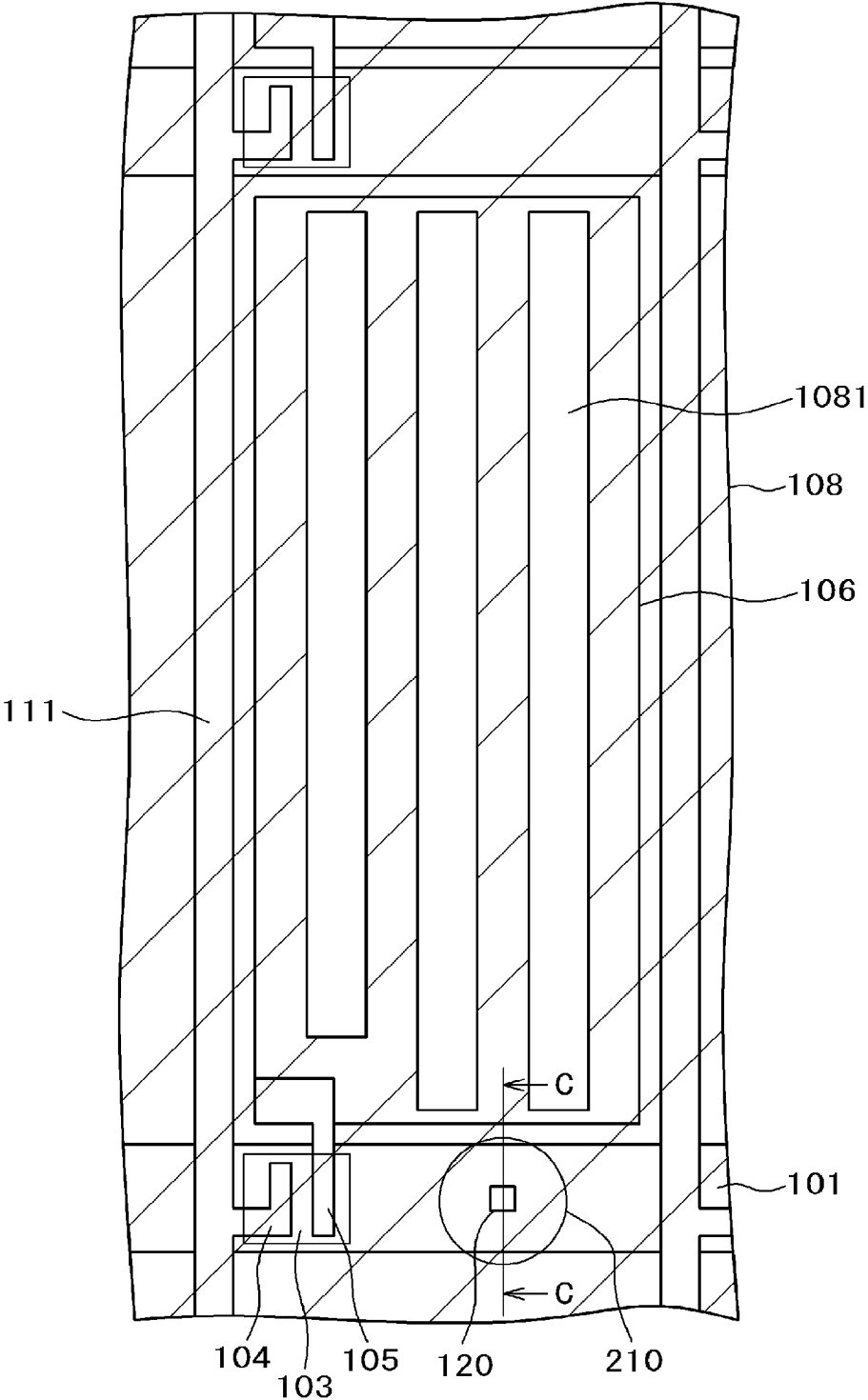

FIG. 21

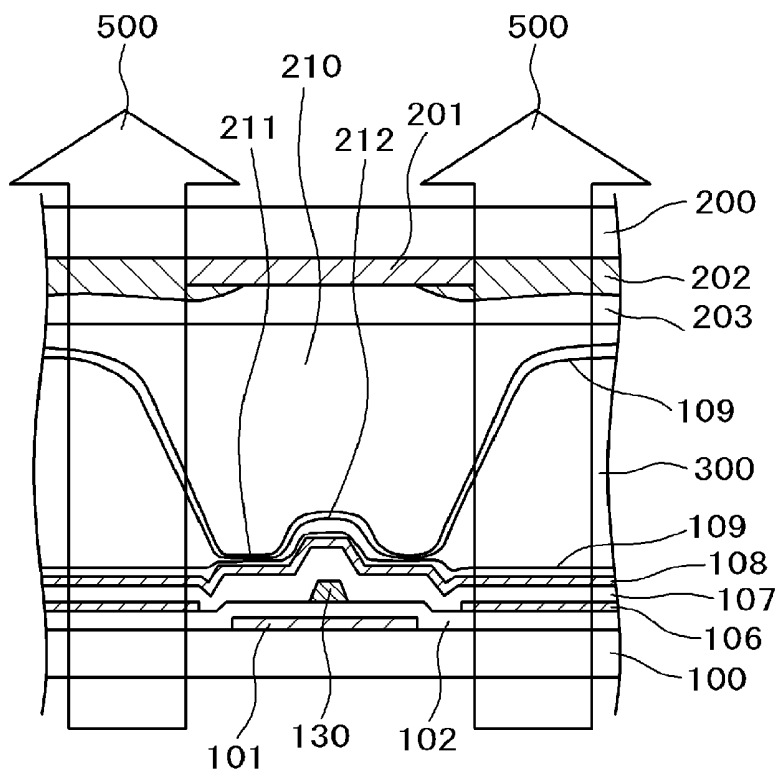
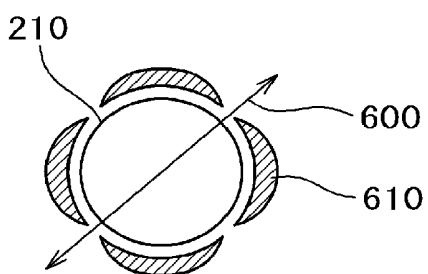

FIG. 22



LIQUID CRYSTAL DISPLAY DEVICE

CLAIM OF PRIORITY

[0001] The present application claims priority from Japanese Patent Application JP 2011-277234 filed on Dec. 19, 2011, the content of which is hereby incorporated by reference into this application.

BACKGROUND OF THE INVENTION

[0002] 1. Field of the Invention

[0003] The present invention relates to a liquid crystal display device. The invention particularly relates to a liquid crystal display device taking measures to prevent bright spots caused by scraped dusts of an alignment film.

[0004] 2. Description of the Related Art

[0005] Liquid crystal display devices include: a TFT substrate having pixel electrodes, thin film transistors (TFT), etc. formed in a matrix; a counter substrate disposed in facing relation to the TFT substrate and having color filters, etc. formed at positions corresponding to the pixel electrodes of the TFT substrate; and liquid crystals put between the TFT substrate and the counter substrate. Images are formed by controlling the light transmittance of liquid crystal molecules for each pixel.

[0006] In the liquid crystal display device, an alignment film is formed at the boundary between the counter substrate and the liquid crystal layer in the TFT substrate, and the alignment film is subject to rubbing process or optical alignment process to put the liquid crystal molecules to initial alignment. Then, the amount of light transmitted through the liquid crystal layer is controlled by twisting or rotating the liquid crystal molecules by electric fields from the state of initial alignment.

[0007] Meanwhile, to control the thickness of the liquid crystal layer, it is necessary to form spacers between the counter substrate and the TFT substrate. Conventionally, beads, etc. were dispersed as the spacers in the liquid crystal layer. In recent years, however, to control the gap between the TFT substrate and the counter substrate more accurately, columnar spacers are formed on the counter substrate and the gap is controlled by the columnar spacers.

[0008] However, use of the columnar spacer additionally raises a new problem. JP-2000-122071-A, JP-2001-33790-A, and JP-2002-229040-A describe the following. When the columnar spacer is formed on the TFT substrate, a reservoir of the alignment film is formed at the periphery of the columnar spacer and the thickness of the alignment film is increased therein. To prevent such increase in the thickness, a concave portion is formed at the top end of the columnar spacer to retain the alignment film in the concave portion thereby preventing increase in the thickness of the alignment film at the periphery of the columnar spacer.

[0009] JP-2009-255529-A describes the configuration in which grooves are formed, for example, of a concentric shape at the top end of the columnar spacer and the liquid alignment film is accumulated in the grooves to prevent scraping of the alignment film after drying. Further, the configuration is adapted to ensure the degree of freedom of the size of a pedestal disposed in facing relation to the columnar spacer.

[0010] JP-2007-94372-A describes the configuration in which grooves are formed at the surface of a pedestal disposed in facing relation to a columnar spacer and the area of contact between the columnar spacer and the pedestal is

adjusted to shorten the recovery time after the substrate has been pressed from the outside.

SUMMARY OF THE INVENTION

[0011] For example, when a columnar spacer is disposed to a counter substrate, a pedestal is disposed to a TFT substrate at a portion facing the columnar spacer. The pedestal disposed to the TFT substrate serves to prevent scraping of the alignment film at a portion in contact with the columnar spacer, prevent displacement of the columnar spacer or adjust the stress caused by an urging pressure, when the counter substrate is pressed, etc.

[0012] However, such effects were not obtained sufficiently in the related art. For example, in the techniques described in JP-2000-122071-A, JP-2001-33790-A, and JP-2002-229040-A, a concave portion is formed at the top of the columnar spacer provided to the TFT substrate to prevent formation of a liquid reservoir of the alignment film at the periphery of the columnar spacer. However, this configuration results in a problem that the alignment film formed thick in the concave portion at the top of the columnar spacer is scraped off from a portion where the columnar spacer is in contact with the counter substrate, and the scraped dusts cause bright spots.

[0013] The technique described in JP-2009-25529-A results in a problem that the alignment film is formed thick in the concentric grooves formed at the top of the columnar spacer, and the thick alignment film is peeled by the contact with the pedestal. Further, in the configuration of JP-2009-25529-A, no sufficient effect can be obtained for the positional displacement of the columnar spacer.

[0014] In the technique described in JP-2007-94372-A, grooves are formed to a pedestal. However, this involves a problem that an alignment film is formed thick in the portion of the grooves and the alignment film is peeled off from the portion. Further, it is difficult by the configuration to suppress the positional displacement of the columnar spacer.

[0015] The present invention intends to prevent scraping of an alignment film between a columnar spacer and a pedestal, prevent positional displacement of the columnar spacer, prevent the columnar spacer from fracture when the counter substrate is pressed, and rapidly recover the initial state when the pressure is removed.

[0016] The present invention intends to overcome the problems described above and typically include the following means. That is, there is provided a liquid crystal display device including: a TFT substrate having gate lines and data lines arranged thereon, the gate lines extending in a first direction and arranged in a second direction, the data lines extending in the second direction and arranged in the first direction; a counter substrate having a black matrix and a color filter; and liquid crystals put between the TFT substrate and the counter substrate. Columnar spacers are formed on the counter substrate. Pedestals are formed on portions of the TFT substrate, the portions corresponding to the columnar spacers. A convex portion and a concave portion are present at the top end of the columnar spacer. The pedestal is formed corresponding to the concave portion. The concave portion is opened at the ends thereof and connected to the lateral side of the columnar spacer.

[0017] In this case, a usual state, that is, a state where pressure is not exerted on the counter substrate includes a case where the pedestal and the concave portion of the columnar spacer are in contact with each other and the convex portion of

the columnar spacer is not in contact with the TFT substrate, and a case where the convex portion of the columnar spacer is in contact with the TFT substrate and the pedestal portion and the concave portion of the columnar spacer are not in contact with each other.

[0018] Further, the convex portion and the concave portion formed to the top end of the columnar spacer can be in various shapes. Further, two or more kinds of columnar spacers may be combined to provide a predetermined effect as a whole.

[0019] According to the invention, since the convex portion and the concave portion are disposed to the top end of the columnar spacer, and the concave portion is opened at the ends thereof and connected to the lateral side of the columnar spacer, the alignment film is not formed thick in the concave portion and, accordingly, scraping of the alignment film caused by the contact between the columnar spacer and the pedestal can be prevented.

[0020] Further, according to the invention, since the convex portion formed at the top end of the columnar spacer serves as a stopper to the pedestal, positional displacement of the columnar spacer can be prevented.

[0021] Further, according to the invention, since one columnar spacer has a portion always in contact with the pedestal and a portion in contact with the pedestal when the counter substrate is pressed, pressure can be dispersed and the counter substrate can be rapidly returned to an initial state when the pressure is released. Further, the columnar spacer can be free from fracture when the counter substrate is pressed.

BRIEF DESCRIPTION OF THE DRAWINGS

[0022] FIG. 1 is a plan view of a liquid crystal display device according to the present invention;

[0023] FIG. 2 is a cross sectional view of a first embodiment;

[0024] FIG. 3 is a plan view showing a relation between a columnar spacer and a pedestal of the first embodiment;

[0025] FIG. 4 is a cross sectional view showing an other example of the first embodiment;

[0026] FIG. 5 is a plan view showing a further example of the first embodiment;

[0027] FIG. 6 is a plan view showing a relation between a first columnar spacer and a pedestal of a second embodiment;

[0028] FIG. 7 is a plan view showing a relation between a second columnar spacer and a pedestal of the second embodiment;

[0029] FIG. 8 is an example showing an arrangement of first and second columnar spacers in the second embodiment;

[0030] FIGS. 9A to 9C are other example showing an arrangement using first columnar spacers and second columnar spacers in the second embodiment;

[0031] FIG. 10 is a modified example showing a relation between the shape of a columnar spacer and a pedestal in the second embodiment;

[0032] FIG. 11 is other modified example showing a relation between the shape of a columnar spacer and a pedestal in the second embodiment;

[0033] FIG. 12 is a cross sectional view showing a relation between a columnar spacer and a pedestal in the third embodiment;

[0034] FIG. 13 is a plan view showing a relation between a columnar spacer and a pedestal in the third embodiment;

[0035] FIG. 14 is a cross sectional view showing other example of the relation between a columnar spacer and a pedestal in the third embodiment;

[0036] FIG. 15 shows an example of an arrangement of columnar spacers in the third embodiment;

[0037] FIG. 16 is a plan view showing a fourth embodiment;

[0038] FIG. 17 is a cross sectional view of the fourth embodiment;

[0039] FIG. 18 is a detailed plan view of the fourth embodiment;

[0040] FIGS. 19A and 19B show a cross sectional view of a fifth embodiment;

[0041] FIG. 20 is a plan view of a sixth embodiment;

[0042] FIG. 21 is a cross sectional view of the sixth embodiment; and

[0043] FIG. 22 is a plan view showing a problem when rubbing alignment is adopted.

DESCRIPTION OF THE PREFERRED EMBODIMENTS

[0044] The present invention will be described specifically by way of preferred embodiments.

First Embodiment

[0045] FIG. 1 is a plan view of a pixel portion of a liquid crystal display device to which the invention is applied. In FIG. 1, gate lines 101 are extended in a lateral direction and arranged in a longitudinal direction. Further, data lines 111 are extended in the longitudinal direction and arranged in the lateral direction. A pixel electrode 106 is formed in a region surrounded by the gate lines 101 and the data lines 111. The pixel electrode 106 is formed as a solid plane on which a not illustrated inorganic passivation film is stacked and a counter electrode 108 having slits 1081 is formed thereover. The counter electrode 108 is formed in common with each of pixels.

[0046] A semiconductor layer 103 is formed over the gate line 101, and a drain electrode 104 and a source electrode 105 are stacked over the semiconductor layer 103. The drain electrode 104 is branched from the data line 111, and the source electrode 105 is connected to the pixel electrode 106. When a voltage is supplied to the pixel electrode 106 by way of the source electrode 105, electric fields are exerted on a liquid crystal layer 300 through the slit 1081 of the counter electrode 108 to rotate liquid crystal molecules and control the amount of light transmitted through the liquid crystal layer 300. In FIG. 1, a pedestal 120 is formed over the gate line 101. A columnar spacer 210 formed on the counter substrate 200 is in contact with the pedestal 120.

[0047] FIG. 2 is a cross sectional view along line A-A in FIG. 1. In FIG. 2, the pedestal 120 formed on a TFT substrate 100 is in contact with a concave portion 212 at the top end of the columnar spacer 210 formed on an overcoat film 203 of a counter substrate 200. In the drawing, the gate line 101 is formed on the TFT substrate 100, and a gate insulating film 102 is formed on the gate line 101. A pedestal base 130 is formed on the gate insulating film 102. The pedestal 120 is formed corresponding to the pedestal base 130.

[0048] The semiconductor layer 103 or a metal layer is stacked in accordance with a necessary height to the pedestal base 130. Layers that can be stacked include 150 nm of the semiconductor layer 103, 200 nm of the source-drain elec-

trodes **105**, **104**, and 70 nm of the pixel electrode **106** formed with ITO (indium tin oxide), etc. Accordingly, when all of the films are stacked, the thickness can be about 420 nm.

[0049] An inorganic passivation film **107** comprising SiN is formed so as to cover the gate insulating film **101** and the pedestal base **130**, and the counter electrode **108** is formed on the inorganic passivation film **107**. The counter electrode **108** over the gate line **101** is formed as a solid film. That is, the counter electrode **108** has the slits **1081** only in the pixel portion. An alignment film **109** is formed so as to cover the counter electrode **108**. The thickness of the alignment film **109** is about 70 nm. In FIG. 2, a pedestal **120** in contact with the columnar spacer **210** is formed corresponding to the pedestal base **130**.

[0050] In FIG. 2, a black matrix **201** is formed on the counter substrate **200**, and an overcoat film **203** is formed on the black matrix. The columnar spacer **210** is formed on the overcoat film **203**. The columnar spacer **210** is formed, for example, of an acryl resin by photolithography. A convex portion **211** and a concave portion **212** are formed at the top end of the columnar spacer **210**. In FIG. 2, a pedestal **120** is in contact with the concave portion **212** of the columnar spacer **210** to keep the TFT substrate **100** and the counter substrate **200** at a predetermined gap. The concave portion **212** and the convex portion **211** at the top end of the columnar spacer **210** can be formed, for example, by half-tone exposure. An alignment film **109** is formed so as to cover the overcoat film **203** and the columnar spacer **210**. Liquid crystals **300** are filled between the TFT substrate **100** and the counter substrate **200**.

[0051] FIG. 3 is a plan view showing a relation between a columnar spacer **210** and a pedestal **120** in the pedestal portion. As shown in FIG. 2, since the cross section of the columnar spacer **210** is trapezoidal, the base portion of the columnar spacer **210** of a large width is referred to as a lower bottom **216** and the top of the columnar spacer **210** of a small width is referred to as an upper bottom **215**. The top end of the columnar spacer **210** is not flat but the convex portion **211** and the concave portion **212** are formed. In FIG. 3, a hatched portion is the convex portion **211** and other portion is a concave portion **212**.

[0052] In FIG. 3, a concave portion **212** has a grooved shape and a groove thereof is opened at both ends. That is, the groove is connected to the lateral side of the columnar spacer **210** not by way of the convex portion. That is, the concave portion **212** is not surrounded at the entire circumference by the convex portion **211**. This is greatly different from the known columnar spacer. Accordingly, after the alignment film **109** is coated in a liquid state, the alignment film **109** does not accumulate in the concave portion **212**, that is, in the groove at the top end of the spacer **210** but flows downwardly on the lateral side of the alignment film **109**. Accordingly, the alignment film **109** is not formed thick in the concave portion **212**.

[0053] The width of the concave portion at the top end of the columnar spacer **210** is increased in the central portion, and the pedestal **120** on the TFT substrate **100** intrudes to this portion. Although the pedestal **120** is square in a plan view, the planar shape is not restricted only thereto but may be circular, rectangular, or elliptic. The planar shape is determined depending on the shape of the pedestal base **130**.

[0054] Since the alignment film **109** is not formed thick in the concave portion **212** of the columnar spacer **210**, scraping of the alignment film does not result in a serious problem. In addition, as shown in FIG. 2 and FIG. 3, since the pedestal **120**

is surrounded by the convex portion **211** of the columnar spacer **210**, even when the counter substrate **200** is pressed from the outside, the columnar spacer **210** does not move easily to the pedestal. Also in this regard, scraping of the alignment film can be prevented. Further, no positional displacement is caused between the TFT substrate **100** and the counter substrate **200**.

[0055] In FIG. 2, when the counter substrate **200** is pressed, the pedestal **120** or the columnar spacer **210** is compressed. In this case, when the convex portion **211** of the columnar spacer **210** is in contact with the facing surface of the TFT substrate **100**, reaction is generated therein to disperse the force. Accordingly, the pedestal **120**, etc. are not fractured. Further, since the reaction increases gradually, the counter substrate **200** can recover the initial state in a short time after removal of the pressure exerted on the counter substrate **200**. Such an effect can be obtained effectively by defining the distance between the convex portion **211** of the columnar spacer **210** and the facing surface of the TFT substrate **100** to 0.2 μm or more.

[0056] FIG. 4 shows another example of this embodiment. The embodiments in FIG. 4 and FIG. 2 are different in that the depth of the concave portion **212** at the top end of the columnar spacer **210** in FIG. 4 is larger than that in FIG. 2 and the convex portion **211** of the columnar spacer **210** is in contact with the facing surface of the TFT substrate **100** in a usual state and the pedestal **120** is not in contact with the concave portion **212** of the columnar spacer **210** in the usual state. The plan view showing a relation between the columnar spacer **210** and the pedestal **120** in the pedestal portion is identical with FIG. 3.

[0057] The configuration can be obtained by increasing the depth of the concave portion **212** of the columnar spacer **210**, and, in addition, by lowering the height of the pedestal **120**. The height of the pedestal **120** can be adjusted depending on the height of the pedestal base **130** formed below. The height can be adjusted by removing the semiconductor layer **103**, the drain electrode layer **104**, or the pixel electrode **106** from the pedestal base **130**.

[0058] In the embodiment in FIG. 4, when a force is exerted on the counter substrate **200**, the convex portion **211** of the columnar spacer **210** is compressed at first. When the force on the counter substrate **200** further increases, the pedestal **120** is in contact with the concave portion **212** of the columnar spacer **210**. This increases the reaction. By the effect as described above, the columnar spacer **210** or the pedestal **120** can be free from fracture and the counter substrate **200** can recover the initial state in a short time after removal of the pressing force therefrom in the same manner as the configuration of FIG. 2. In FIG. 4, the distance between the top end of the pedestal **120** and the concave portion **212** of the columnar spacer **210** is preferably 0.2 μm or more.

[0059] FIG. 5 is a plan view showing a further example of this embodiment. While the columnar spacer **210** in FIG. 2 and FIG. 4 is a truncated cone having a circular shape in a plan view as shown in FIG. 3, the spacer in FIG. 5 is a truncated pyramidal cone having a square shape in a plan view. The top end of the columnar spacer **210** in FIG. 5 is square, and convex portions **211** are formed each at the corners of the square shape. The concave portion **212** is formed in a grooved shape from the central portion where the pedestal **120** intrudes to each of the sides and the groove is opened to the lateral side of the columnar spacer **210**.

[0060] Since the liquid material of the light alignment film flows from the grooved portion formed at the top end of the columnar spacer **210** to the lateral side of the columnar spacer **210**, the alignment film **109** is not formed thick in the concave portion **212**. Accordingly, scraping of the alignment film caused by contact between the pedestal **120** and the columnar spacer **210** can be prevented. Further, since the pedestal **120** is surrounded by the convex portion **211** of the columnar spacer **210**, the problem of positional displacement between the counter substrate **200** and the TFT substrate **100** does not occur.

[0061] Also in the case where the columnar spacer **210** and the pedestal **120** have a planar shape as shown in FIG. 5, the cross sectional shape of the columnar spacer **210** and the pedestal **120** can be in the same configuration as in FIG. 2 or FIG. 4. Accordingly, when the counter substrate **200** is pressed from the outer side, the columnar spacer **210** or the pedestal **120** can be free from fracture and the recovery time to the initial state upon removal of pressure on the counter substrate **200** can also be shortened.

Second Embodiment

[0062] FIGS. 6 to 8 are views showing the shape and the arrangement of the columnar spacers **210** according to a second embodiment of the invention. FIG. 6 and FIG. 7 are plan views showing the state where the pedestal **120** intrudes to the concave portion **212** of the columnar spacer **210**.

[0063] FIG. 6 shows a state in which a groove-shaped concave portion **212** opened at the ends thereof in the longitudinal direction, that is, in a y direction is formed on the top end of the columnar spacer **210**. FIG. 7 shows a state in which a groove-shaped concave portion **212** opened at the ends thereof in the lateral direction, that is, in an x direction is formed on the top end of the columnar spacer **210**.

[0064] In both of the columnar spacer **210** in FIG. 6 and the columnar spacer **210** in FIG. 7, since the concave portion **212** is opened at the ends and the liquid alignment film flows to the outside, the alignment film **190** is not formed thick in the concave portion **212**. Accordingly, scraping of the alignment film can be prevented.

[0065] In FIG. 6, the pedestal **120** cannot move in the lateral direction, that is, in the x direction due to the presence of the convex portion **211** of the columnar spacer **210**. That is, lateral displacement between the counter substrate **200** and the TFT substrate **100** can be prevented. In FIG. 7, the pedestal **120** cannot move in the longitudinal direction, that is, in the y direction due to the presence of the convex portion **211** of the columnar spacer **210**. That is, longitudinal displacement between the counter substrate **200** and the TFT substrate **100** can be prevented.

[0066] Accordingly, displacement between the TFT substrate **100** and the counter substrate **200** can be suppressed in both of the x direction and the y direction by the combination of the columnar spacer **210** in FIG. 6 and the columnar spacer **210** in FIG. 7. FIG. 8 is an example in which such effects can be obtained by the combination of the columnar spacer **210** shown in FIG. 6 and the columnar spacer **210** shown in FIG. 7.

[0067] In FIG. 8, each of blank circles represents the columnar spacer **210** as shown in FIG. 6 and each of hatched circles represents the columnar spacer **210** as shown in FIG. 7. In FIG. 8, positional displacement between the TFT substrate **100** and the counter substrate **200** in both of the x direction and the y direction is prevented by alternately

arranging the columnar spacers **210** shown in FIG. 6 and the columnar spacers **210** shown in FIG. 7.

[0068] Incidentally, when the counter substrate **200** of the liquid crystal display panel is pressed by a finger, an identical stress is not applied to all of the regions in a display region **400**. For example, when a central portion of the display region **400** is pressed shown in FIG. 9C, a stress in the y direction is applied in a region A near the longer side of the display region **400**, and a stress in the x direction is applied in the region B near the shorter side. For preventing the positional displacement by the stresses, in the region A of FIG. 9C, displacement in the y direction can be prevented by using more number of the columnar spacers **210** shown in FIG. 9A where the groove at the top end of the columnar spacer **210** is formed in the x direction. Displacement in the x direction can be prevented by using more number of columnar spacers **210** in the region B of FIG. 9C where the groove at the top end of the columnar spacer **210** is formed in the y direction.

[0069] FIG. 10 and FIG. 11 are plan views for the combination of the columnar spacer **210** and the pedestal **120** showing other examples of this embodiment. FIG. 10 shows an example where convex portions **211** are formed by the number of three each at 120° interval in view of polar coordination at the top end of the columnar spacer **210**. Then, concave portions **212** each opened at the end are formed by the number of three. A pedestal **120** intrudes to the concave portion **212** of each of the regions partitioned by the three convex portions **211**.

[0070] In FIG. 11, three convex portions **211** formed at the top end of the columnar spacer **210** are disposed each to a position rotated by 60 degree when compared with FIG. 10. Other shapes are identical with those in FIG. 10. By the combined use of the columnar spacer **210** shown in FIG. 10 and the columnar spacer **210** shown in FIG. 11, the configuration can be attained in which the displacement is suppressed in any of the x direction and the y direction of a display region **400** shown at FIG. 9C.

[0071] FIG. 10 and FIG. 11 are in such a relation that the convex portions **211** at the top end of the columnar spacer **210** are rotated each by 60 degree. In this case, when the number of the convex portions **211** formed at the top end of the columnar spacer **210** is defined as 3, the rotational angle of the convex portions **211** can be calculated as $360/(3 \times 2)$. The number of the convex portions **211** at the top end of the columnar spacer **210** can also be the number of n which is 4 or greater. In this case, a liquid crystal display panel with less displacement between the counter substrate **200** and the TFT substrate **100** can be attained by defining the positions of the convex portions **211** in the two types of the columnar spacers **210** in such a relation that they are rotated by $360/(n \times 2)$ and arranging the two kinds of the columnar spacers **210** in combination.

Third Embodiment

[0072] FIG. 12 is a cross sectional view showing a relation between a columnar spacer **210** and a pedestal **120**. FIG. 13 is a plan view of a combination of the columnar spacer **210** and the pedestal **120** as viewed on the side of the TFT substrate **100**. As shown in FIG. 12 and FIG. 13, a convex portion **211** and a concave portion **212** are formed each by one on the top end of the columnar spacer **210**. The concave portion **212** is opened to the outside except for the side of the convex portion **211** and, accordingly, the material of the alignment film does

not form a liquid reservoir. That is, the alignment film 109 is not formed thick in the concave portion 212.

[0073] In FIG. 12, a convex portion 211 and a concave portion 212 are formed at the top end of a columnar spacer 210. While the convex portion 211 is in contact with the TFT substrate 100, the pedestal 120 formed on the TFT substrate 100 is not in contact with the concave portion 212 at the top end of the columnar spacer 210. When an external force is exerted on the counter substrate 200 of the liquid crystal display panel, the pedestal 120 of the TFT substrate 100 and the concave portion 212 of the columnar spacer 210 are in contact with each other to generate larger reaction. Accordingly, the stress to the pressure can be increased gradually, and the recovery time to the initial state when pressure is removed can be shortened.

[0074] In FIG. 14, contrary to FIG. 12, a pedestal 120 formed on the TFT substrate 100 is in contact with a concave portion 212 of a columnar spacer 210, but the convex portion 211 of the columnar spacer 210 is not in contact with the TFT substrate 100. When an external force is exerted on the counter substrate 200 of the liquid crystal display panel, the concave portion 211 of the columnar spacer 210 and the TFT substrate 100 are in contact with each other to cause greater reaction. The effect is identical with that in FIG. 12. The plan view on the side of the TFT substrate 100 in FIG. 14 is identical with that of FIG. 13.

[0075] In FIG. 12 or FIG. 14, the pedestal 120 constrains the movement of the columnar spacer 210 only in one direction. That is, the movement cannot be restricted in the direction other than the direction where the convex portion 211 is formed at the top end of the columnar spacer 210. In this embodiment, positional displacement between the TFT substrate 100 and the counter substrate 200 is prevented as the entire liquid crystal display panel by arranging the columnar spacers 210 in FIG. 12 or FIG. 14 while changing the direction thereof.

[0076] FIG. 15 is an example of arranging the columnar spacers 210 in this embodiment. In a plan view for the columnar spacers 210 in FIG. 15, the protrusion 211 is formed on the left in the spacer A, the protrusion 211 is formed on the right in the spacer B, the protrusion 211 is formed above in the spacer C and the convex portion 211 is formed below in the spacer D. In FIG. 15, pixels partitioned by the gate lines 101 and the data lines 111 are arranged by the number of 15. The pedestal 120 is formed over the gate line 101 and the columnar spacer 210 is also arranged over the gate line 101.

[0077] As shown in FIG. 15, spacers A in which the convex portion 211 is formed on the left at the top end of the columnar spacer 210 and spacers B in which the convex portion 211 is formed on the right at the top end of the columnar spacer 210 are arranged alternately over the uppermost gate line 101. Further, spacers C in which the convex portion 211 is formed above at the top end of the columnar spacer 210 are arranged over the second gate line 101 from above. Spacers A in which the convex portion 211 is formed on the left and spacer B in which the convex portion 211 is formed on the right are alternately arranged over the third gate line 101 from above. In this case, they are arranged while displacing the relation between the spacers A and B each by one row relative to the row of the pixels from the arrangement over the uppermost gate line 101. Spacers D in which the convex portion 211 is formed below at the top end of the columnar spacer 210 are arranged over the lowermost gate line 101.

[0078] As described above, in this embodiment, displacement between the TFT substrate 100 and the counter substrate 200 is restricted over the entire display region 400. Arrangement for the columnar spacers A, B, C, and D shown in FIG. 15 is illustrated as an example and the relation of the number may be changed for the columnar spacers A, B, C, and D depending on the place as shown in the example of FIGS. 9A to 9C.

[0079] Further, in the plan view of the columnar spacer 210 in FIG. 15, while the boundary between the convex portion 211 and the concave portion 212 is identical with the extending direction of the data line 111 or the gate line 101, this embodiment is not restricted thereto but the boundary between the convex portion 211 and the concave portion 212 may be at a predetermined angle relative to the data line 111 or the gate line 101. It is important in four types of the columnar spacers 210 that the directions of the boundary lines between the convex portion 211 and the concave portion 212 are different by 90° from each other.

Fourth Embodiment

[0080] FIGS. 16 to 18 are views showing a fourth embodiment of the invention. In the first to third embodiments, the pedestal 120 is formed over the gate line 101. The pedestal 120 is formed by forming the pedestal base 130 below, for example, by using the semiconductor layer 103, the drain electrode layer 104, the pixel electrode layer 106, etc. In this embodiment, the drain electrode 104 and the source electrode 105 of the TFT are utilized as the pedestal base 130 without additionally forming the pedestal base 130.

[0081] FIG. 16 is a plan view of a pixel in this embodiment. In FIG. 16, a TFT is formed over a gate line 101 and a columnar spacer 210 is arranged to the portion of the TFT. Other configurations are identical with those explained in FIG. 1.

[0082] FIG. 17 is a cross sectional view along line B-B in FIG. 16. In FIG. 17, a gate line 101 is formed over a TFT substrate 100 and a gate insulating film 102 is formed over the gate line 101. A semiconductor layer 103 is formed over the gate insulating film 102, and a drain electrode 104 and a source electrode 105 are disposed over the semiconductor layer 103. The drain electrode 104 and the source electrode 105 also serve as a pedestal base 130. An inorganic film 107 is formed so as to cover the drain electrode 104 and the source electrode 105, and an alignment film 109 is formed thereover. The configuration on the side of the counter substrate 200 is identical as has been described with reference to FIG. 2.

[0083] A convex portion 211 and a concave portion 212 are formed at the top end of a columnar spacer 210 formed over an overcoat film 203 of a counter substrate 200. In FIG. 17, a convex portion 211 at the top end of the columnar spacer 210 is in contact with the TFT substrate 100. A concave portion 212 of the columnar spacer 210 is not in contact with a pedestal 120 formed on the TFT substrate 100. Then, when pressure is exerted on the counter substrate 200 of the liquid crystal display panel, the convex portion 211 at the top end of the columnar spacer 210 is compressed and the concave portion 212 of the columnar spacer 210 and the pedestal 120 are in contact with each other.

[0084] FIG. 18 is a plan view showing a relation between the drain electrode 104 and the source electrode 105 used as the pedestal base 130, and the convex portion 211 and the concave portion 212 of the columnar spacer 210. In FIG. 18, the drain electrode 104 and the source electrode 105 formed

over the semiconductor layer **103** are arranged corresponding to the concave portion **212** of the columnar spacer **210**. The drain electrode **104** and the source electrode **105** are constrained by the convex portion **211** formed at the top end of the columnar spacer **210**. As a result, positional displacement between the TFT substrate **100** and the counter substrate **200** in the liquid crystal display panel can be prevented.

[0085] In FIG. 18, since the concave portion **212** at the top end of the columnar spacer **210** is opened at the ends, the liquid material of the alignment film does not accumulate in the concave portion. Accordingly, since the alignment film **109** is not formed thick in the concave portion, occurrence of bright spots caused by scraping of the alignment film can be suppressed. As described above, this embodiment has an advantage that the same configuration as in the existent embodiment can be used on the side of the TFT substrate **100** and, accordingly, can be formed by using the same mask as in the existent embodiment.

[0086] In the configuration of FIG. 17, the top end of the pedestal **120** formed by the drain electrode **104** and the source electrode **105** are not in contact with the concave portion **212** of the columnar spacer **210** in a usual state. Alternatively, by decreasing the height of the convex portion **211** of the columnar spacer **210**, it may be configured such that the pedestal **120** and the concave portion **212** of the columnar spacer **210** are always in contact with each other, and the convex portion **211** of the columnar spacer **210** and the TFT substrate **100** are in contact with each other when a pressure is exerted on the counter substrate **200** in the same manner as shown in FIG. 2.

Fifth Embodiment

[0087] FIGS. 19A and 19B are cross sectional views showing a fifth embodiment of the invention. FIG. 19A is identical with FIG. 17. In FIG. 19B, a convex portion **211** is not formed on a columnar spacer **210**. In FIG. 19B, the columnar spacer **210** is not in contact with a pedestal **120** formed by a drain electrode **104** and a source electrode **105** in a usual state of a columnar spacer **210**, that is, in a state where pressure is not exerted on a counter substrate **200**.

[0088] Particularly, in this embodiment, when a pressure is exerted on the counter substrate **200** of the liquid crystal display panel, the stress is dispersed by the combined use of the columnar spacers **210** in FIG. 19A and in FIG. 19B, and the time to recovery the initial state is shortened upon pressure is removed. That is, when the pressure is exerted on the counter substrate **200** of the liquid crystal display panel, the columnar spacer **210** shown in FIG. 19B is at first in contact with the pedestal **120** and, when the pressure is further exerted, the concave portion **212** of the columnar spacer **210** shown in FIG. 19A is in contact with the pedestal **120**. Depending on the gap between the columnar spacer **210** and the pedestal **120**, the order of contact between the spacer and the pedestal may be reversed.

Sixth Embodiment

[0089] In the invention, it is essential to form the convex portion **211** and the concave portion **212** at the top end of the columnar spacer **210**. Accordingly, the diameter of the columnar spacer **210** of the invention tends to be increased. The pedestal **120** and the columnar spacer **210** are often formed at the portion corresponding to the gate line **101**. Although the gate line **101** is formed at a large width, when

the diameter is larger as in the columnar spacer **210** of the invention, the columnar spacer may sometimes protrude out of the gate line **101**.

[0090] In FIG. 20, a columnar spacer **210** is disposed over a gate line **101** and, since the diameter of the columnar spacer **210** is large, the formed columnar spacer **210** is formed in a state of protruding from the gate line **101**. Other configurations of FIG. 20 are identical with those of FIG. 1. In a portion where the columnar spacer **210** is formed, alignment of liquid crystals becomes abnormal to generate domains when rubbing alignment is adopted.

[0091] FIG. 22 is a plan view showing a state in which a not rubbed portion is left at the periphery of a columnar spacer **210** when initial alignment is applied to the counter substrate **200** by a rubbing treatment, and light leakage **610** is caused at that portion. In FIG. 22, an arrow shows the rubbing direction **600**. In FIG. 22, since the columnar spacer **210** has a height, not rubbed portions are formed at the periphery of the columnar spacer **210** as shown by hatched lines in FIG. 22. The portions cause light leakage **610** to deteriorate the contrast. Accordingly, the portions have to be shielded against light, for example, by a black matrix **201** or the like formed on the counter substrate **200**. However, transmittance of the liquid crystal display panel is deteriorated.

[0092] This embodiment intends not to deteriorate the transmittance even when the diameter of the columnar spacer **210** is large, by utilizing also the lateral side of the columnar spacer **210** as the display region by adopting the optical alignment together in the invention. In the optical alignment, a polarized UV light is applied to the alignment film **109** thereby causing monoaxial anisotropy and conducting initial alignment of liquid crystals. Accordingly, since alignment ability can be obtained in the optical alignment by polarized UV light irradiation, the rubbing shadow **610** which is generated in the rubbing alignment is not caused.

[0093] FIG. 21 is a cross sectional view along line C-C in FIG. 20. In FIG. 21, the configuration on the side of a TFT substrate **100** is identical with that of FIG. 2 or FIG. 4. A black matrix **201** and a color filter **202** are formed on a counter substrate **200** and an overcoat film **203** is formed so as to cover them. A columnar spacer **210** is formed over the overcoat film **203**. The diameter of the columnar spacer **210** is larger than the width of the gate line **101**.

[0094] In the rubbing alignment, since the rubbing shadow is generated, the width of the black matrix **201** is formed larger than the diameter of the columnar spacer **210** to prevent deterioration of the contrast. However, in the invention, the width of the black matrix **201** is smaller than the diameter of the columnar spacer **210** as shown in FIG. 21. The diameter means herein the diameter of the columnar spacer **210** in a trapezoidal cross section for a portion having a larger width, that is, the diameter of a lower bottom **216**. Specifically, also the lateral side of the columnar spacer **210** is used as the display region **400** as shown by arrows **500** that show a transmission light in FIG. 21.

[0095] The alignment film **109** is formed also on the lateral side of the columnar spacer **210** and by a polarized UV light irradiation to the alignment film **109**, alignment ability is provided to liquid crystal molecules. Since the columnar spacer **210** has a predetermined height, the thickness of the alignment film **109** tends to be decreased on the lateral side of the columnar spacer **210**. Also in such a case, the alignment

film **109** can be formed at such a thickness that can provide optical alignment up to about $\frac{2}{3}$ the height of the columnar spacer **210**.

[0096] As described above according to this embodiment, since it is not necessary to enlarge the light shielding region by the black matrix **201** also in the configuration where the convex portion **211** and the concave portion **212** are formed at the top end of the columnar spacer **210** and the diameter of the columnar spacer **210** is increased, degradation of the transmittance of the liquid crystal display panel can be suppressed.

1. A display device comprising a transistor substrate and a counter substrate opposing to the transistor substrate, wherein the counter substrate comprising a first spacer, the transistor substrate comprising a transistor having a drain electrode, a source electrode and a semiconductor layer, a pixel electrode electrically connecting the transistor, and a second spacer, the first spacer opposing to the second spacer, the first spacer having a long side along a first direction, a length of the first spacer along the first direction is longer than the length of the second spacer along the first direction, the second spacer overlaps the source electrode and the drain electrode, in a plan view.
2. The display device according to claim 1, wherein the second spacer overlaps with the semiconductor layer, in a plan view.
3. The display device according to claim 1, wherein a gap exists between an edge of the first spacer in the first direction and the transistor substrate.

4. The display device according to claim 1, wherein the first spacer having a first area opposing to the second spacer and a second area not opposing to the second spacer.
5. The display device according to claim 1, wherein the counter substrate further comprising a third spacer, the transistor substrate further comprising a fourth spacer, the third spacer having a long side in a second direction which is different from the first direction, a length of the third spacer in the second direction is longer than a length of the fourth electrode in the second direction.
6. The display device according to claim 1, wherein the first spacer having a concave portion, the second spacer contracts with the concave portion.
7. The display device according to claim 1, wherein a height of the first spacer is bigger than a height of the second spacer.
8. The display device according to claim 1, wherein the first substrate further comprising a plurality of data lines and a plurality of gate lines, the pixel electrode is formed in a pixel area surrounded by the plurality of data lines and the plurality of gate lines, the plurality of the gate lines include a first gate line and a second gate line, wherein the second spacer overlaps with the first gate line and the fourth spacer overlaps with a second gate line.
9. The display device according to claim 1, wherein the first gate line and the second gate line are adjacent to each other.

* * * * *

专利名称(译)	液晶显示装置		
公开(公告)号	US20160097947A1	公开(公告)日	2016-04-07
申请号	US14/968042	申请日	2015-12-14
[标]申请(专利权)人(译)	株式会社日本显示器		
申请(专利权)人(译)	日本展示INC.		
当前申请(专利权)人(译)	日本展示INC.		
[标]发明人	TOMIOKA YASUSHI KUNIMATSU NOBORU HYODO YOSUKE KANEKO TOSHIKI MATSUMOTO YUKO		
发明人	TOMIOKA, YASUSHI KUNIMATSU, NOBORU HYODO, YOSUKE KANEKO, TOSHIKI MATSUMOTO, YUKO		
IPC分类号	G02F1/1339 G02F1/1362 G02F1/1368		
CPC分类号	G02F1/13394 G02F2001/13396 G02F1/136286 G02F1/1368 G02F2001/13398 G02F1/1339		
优先权	2011277234 2011-12-19 JP		
其他公开文献	US9746718		
外部链接	Espacenet USPTO		

摘要(译)

一种液晶显示装置，包括：TFT基板，其上设置有栅极线 and 数据线，栅极线沿第一方向延伸并沿第二方向排列，数据线沿第二方向延伸并沿第一方向排列；具有黑矩阵和滤色器的对向基板；液晶放在TFT基板和相对基板之间。柱状间隔物形成在对向基板上。基座形成在TFT基板的部分上，这些部分对应于柱状隔离物。凸起部分和凹入部分存在于柱状衬垫的顶端。基座对应于凹入部分形成。凹部在其端部开口并连接到柱状衬垫的侧面。

having gate lines and data lines arranged thereon, the gate lines extending in a first direction and arranged in a second direction, the data lines extending in the second direction and arranged in the first direction; a counter substrate having a