



US 20150116621A1

(19) **United States**

(12) **Patent Application Publication**  
**PARK et al.**

(10) **Pub. No.: US 2015/0116621 A1**  
(43) **Pub. Date: Apr. 30, 2015**

(54) **CURVED LIQUID CRYSTAL DISPLAY PANEL**

(52) **U.S. Cl.**

(71) Applicant: **Samsung Display Co., LTD.,**  
Yongin-City (KR)

CPC ..... **G02F 1/13394** (2013.01); **G02F 1/136209**  
(2013.01); **G02F 1/133514** (2013.01); **G02F**  
**2001/136222** (2013.01); **G02F 2001/133519**  
(2013.01)

(72) Inventors: **Min-Wook PARK**, Asan-si (KR);  
**Joo-Hwan PARK**, Yongin-si (KR);  
**Jeong-Man SON**, Suwon-si (KR)

(57) **ABSTRACT**

(73) Assignee: **Samsung Display Co., LTD.,**  
Yongin-City (KR)

(21) Appl. No.: **14/249,164**

(22) Filed: **Apr. 9, 2014**

(30) **Foreign Application Priority Data**

Oct. 30, 2013 (KR) ..... 10-2013-0130225

**Publication Classification**

(51) **Int. Cl.**

**G02F 1/1339** (2006.01)  
**G02F 1/1335** (2006.01)  
**G02F 1/1362** (2006.01)

A curved liquid crystal display panel includes a first substrate, a liquid crystal layer and a second substrate. The first substrate includes a column spacer fixedly anchored to and protruding therefrom. The second substrate includes a stepless preliminary contact area corresponding to a contact-making free end of the column spacer where the preliminary contact area is part of a larger and also non-stepped area. The second substrate is combined with the first substrate to receive the liquid crystal layer therebetween. The non-stepped area is dimensioned to account for shift of the where the contact-making free end of the column spacer makes contact due to the curvature of the first and second substrates.

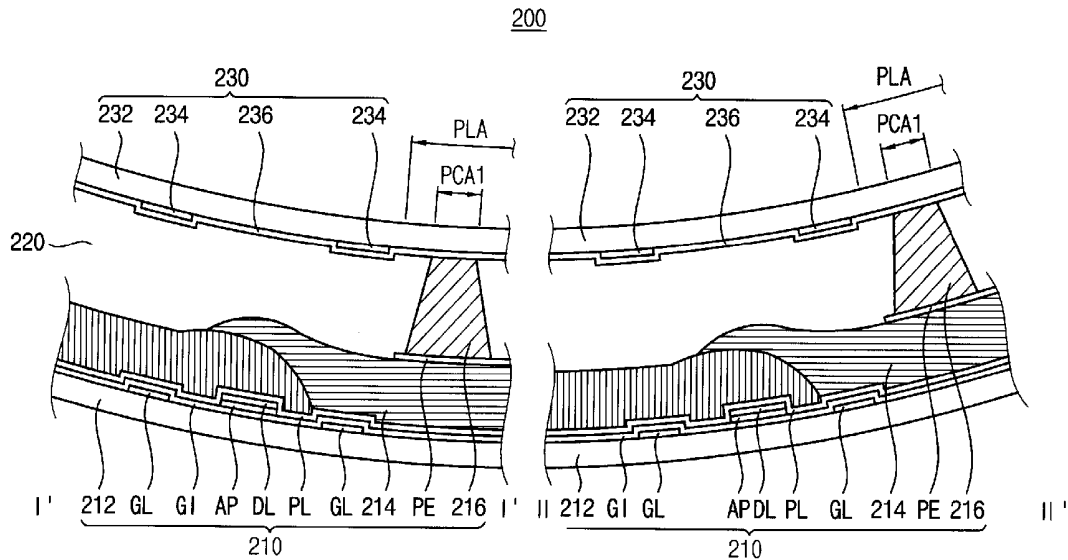

FIG. 1

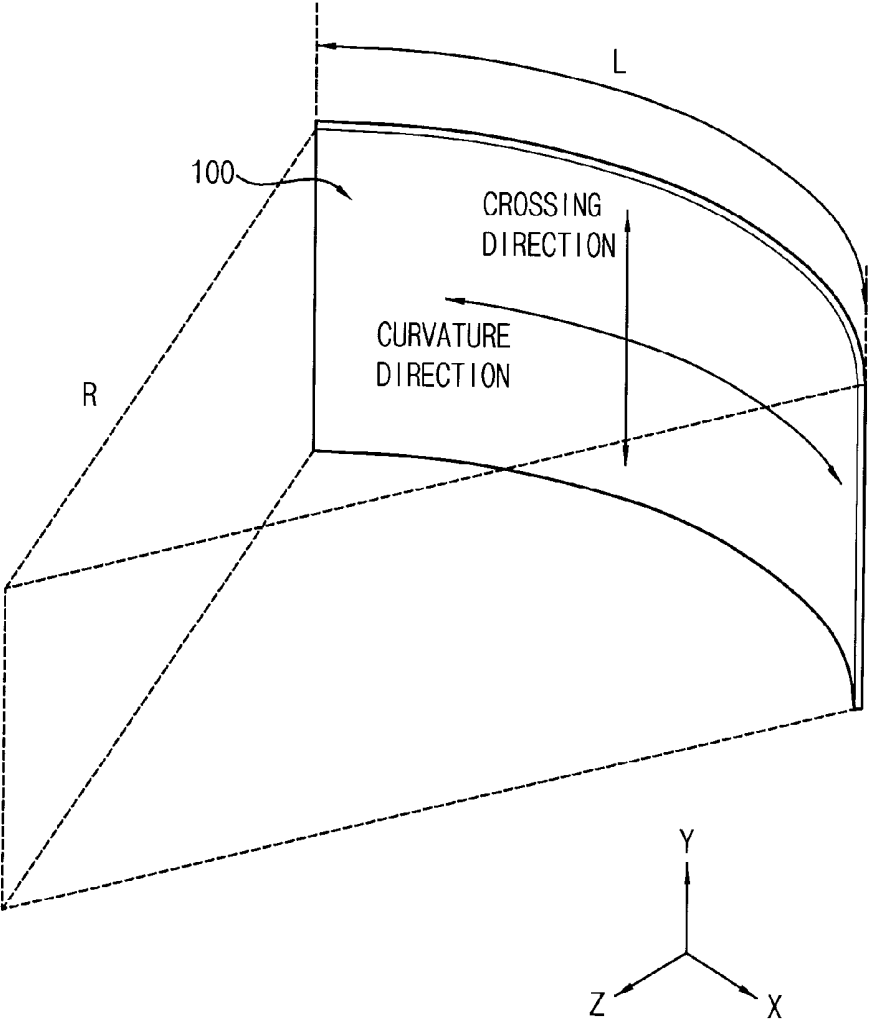

FIG. 2A

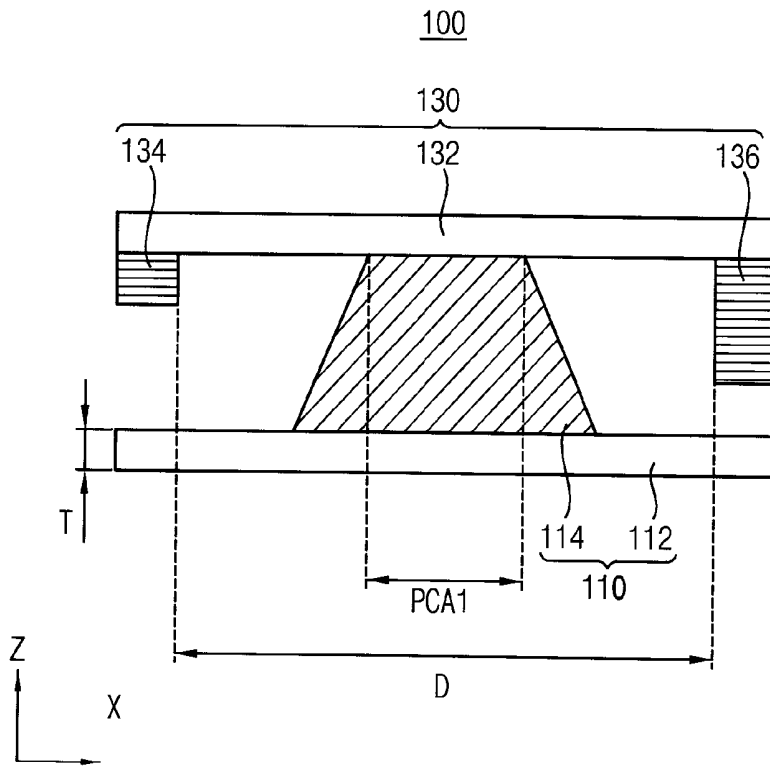

FIG. 2B

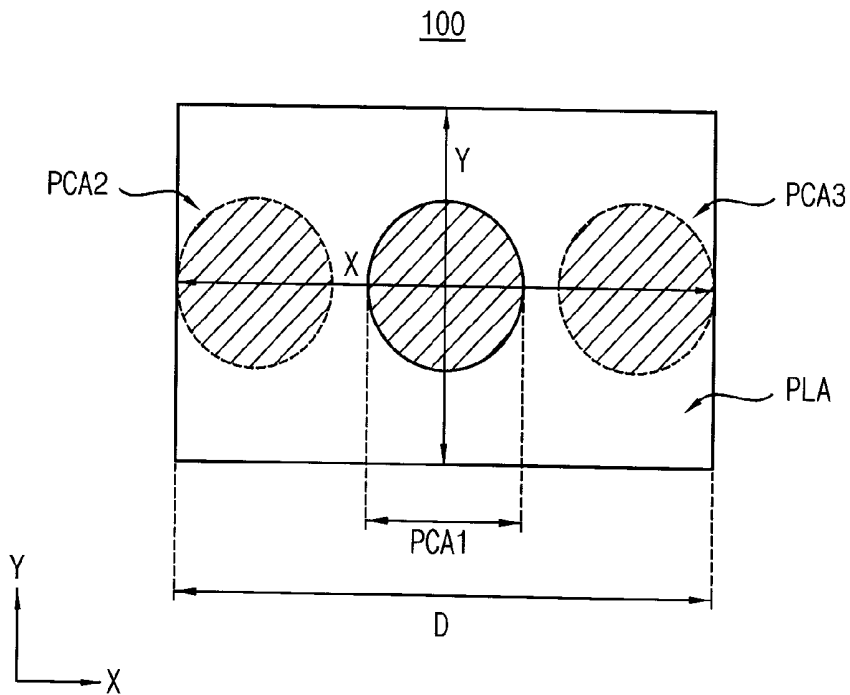

FIG. 3

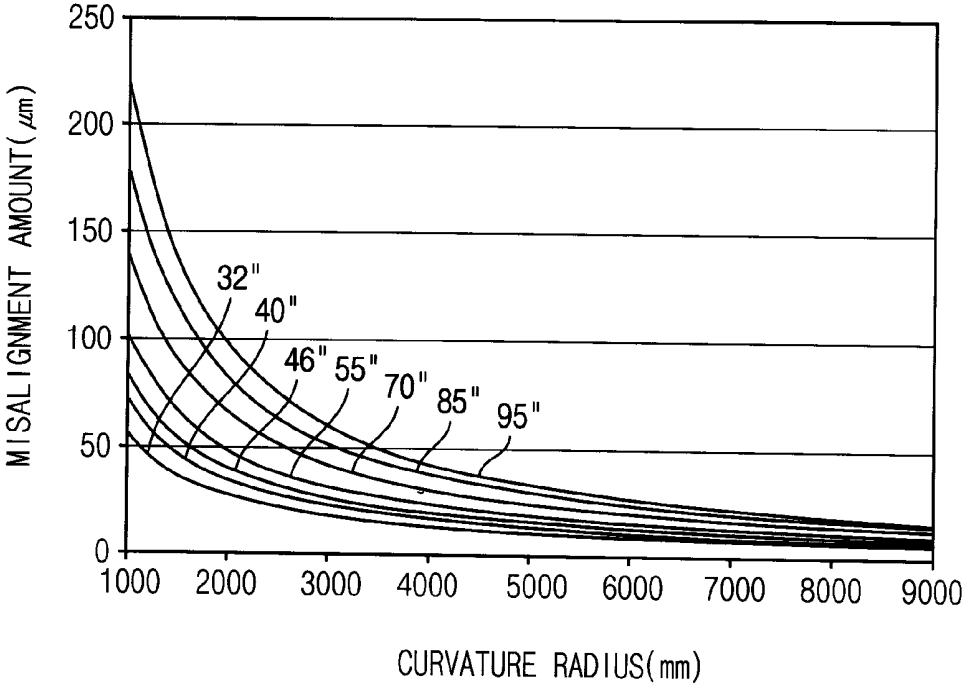

FIG. 4

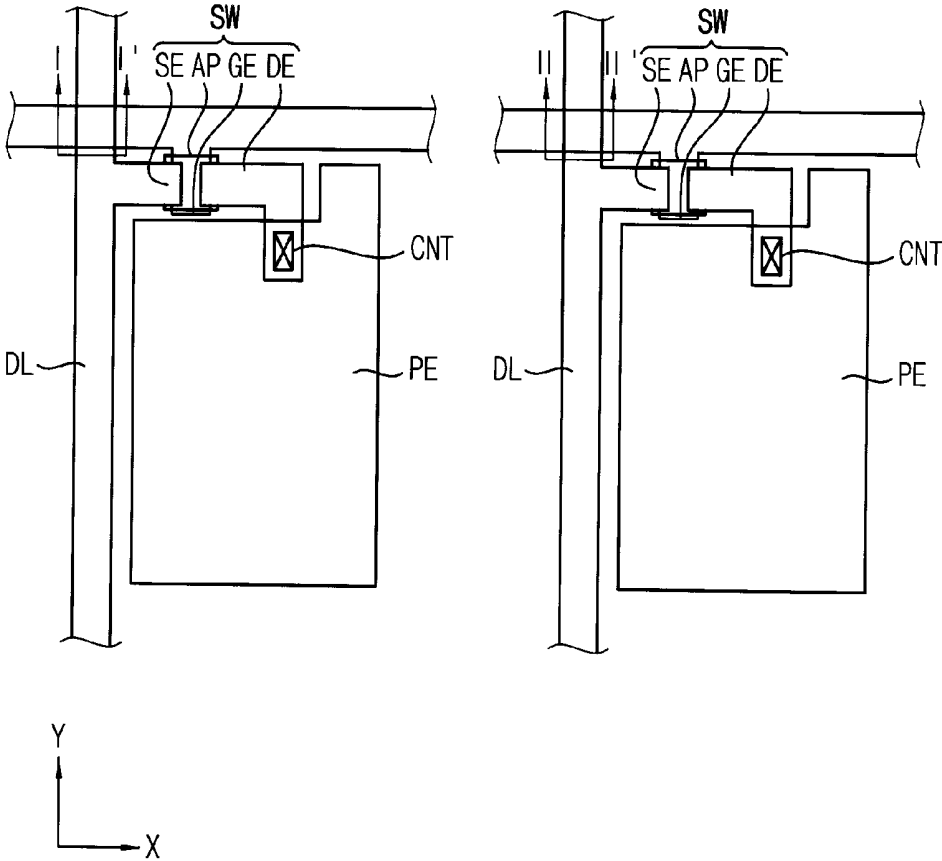

FIG. 5

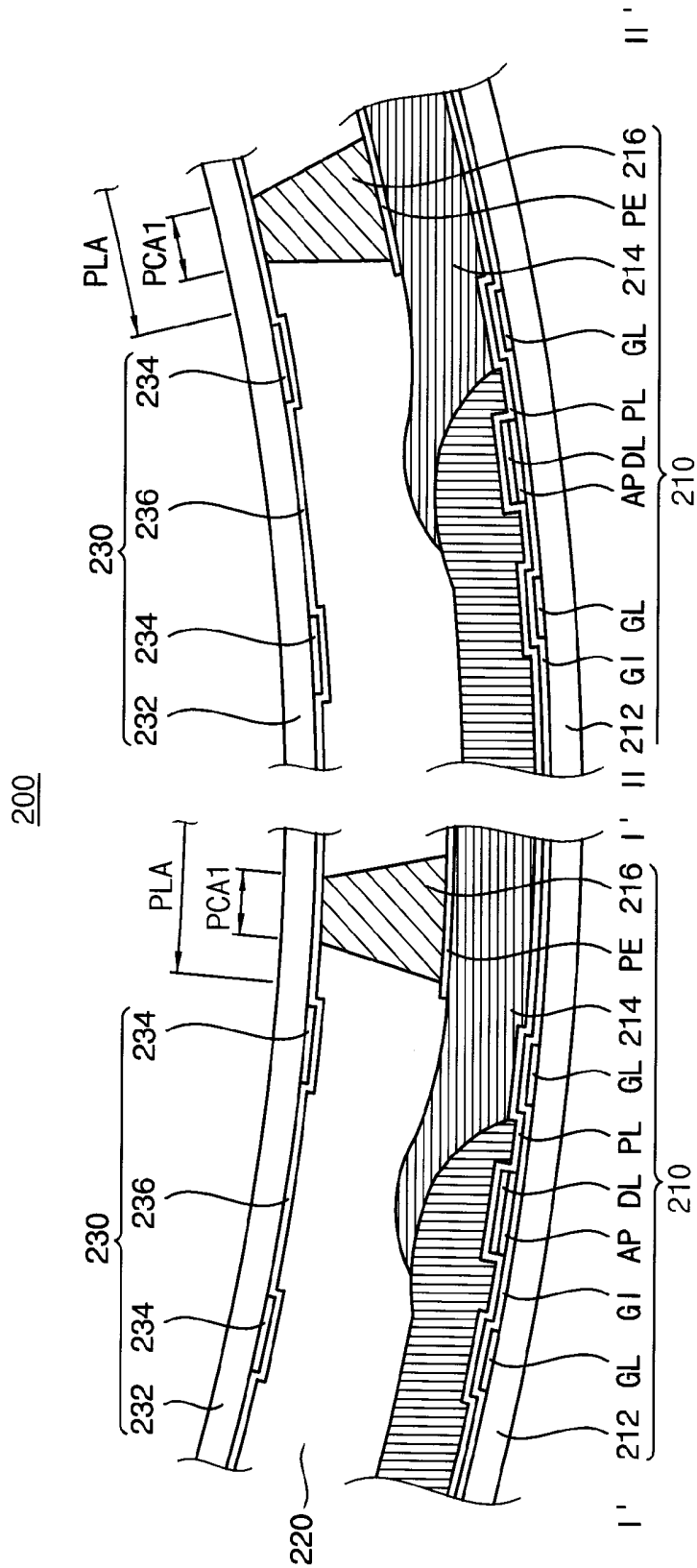

FIG. 6

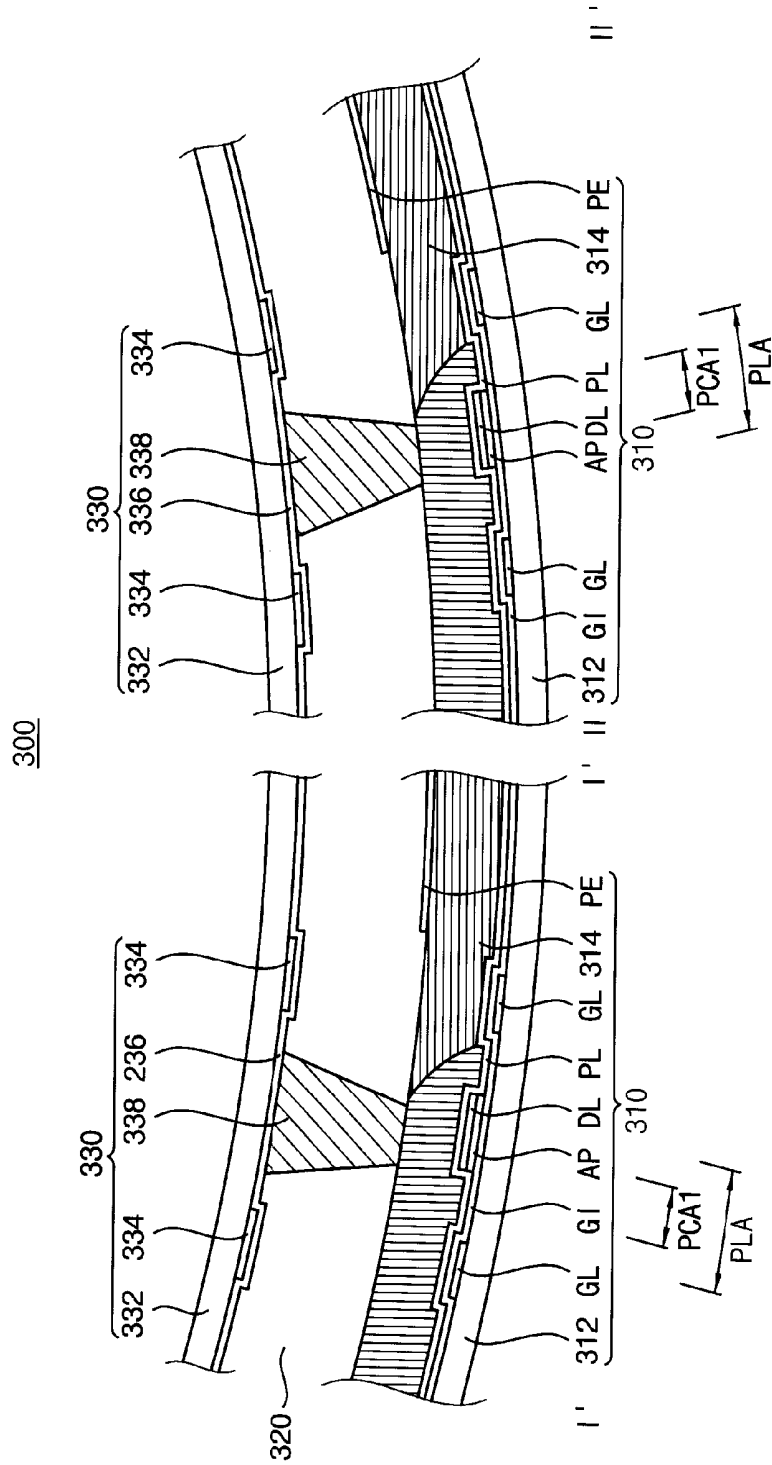

FIG. 7

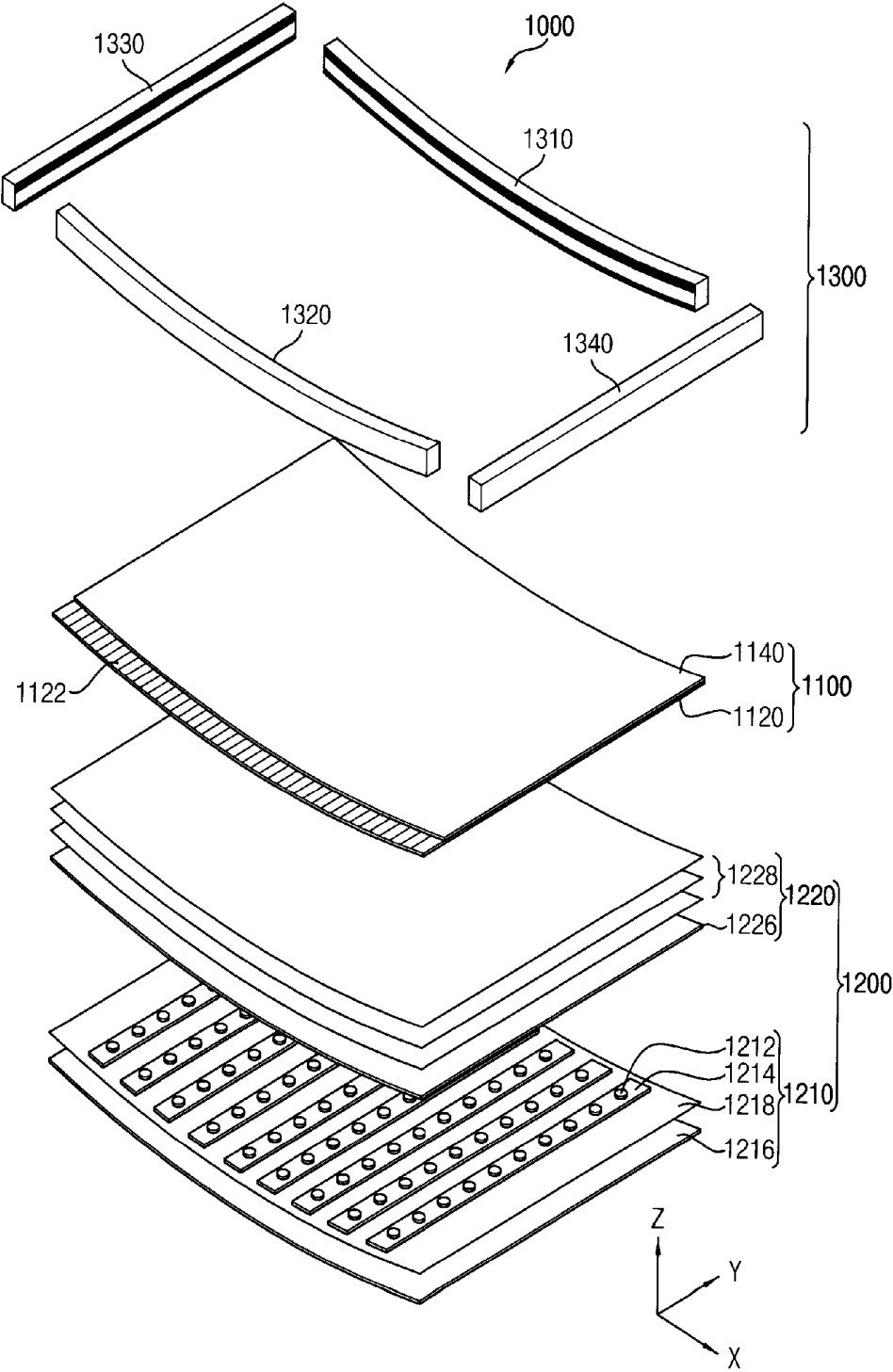

FIG. 8

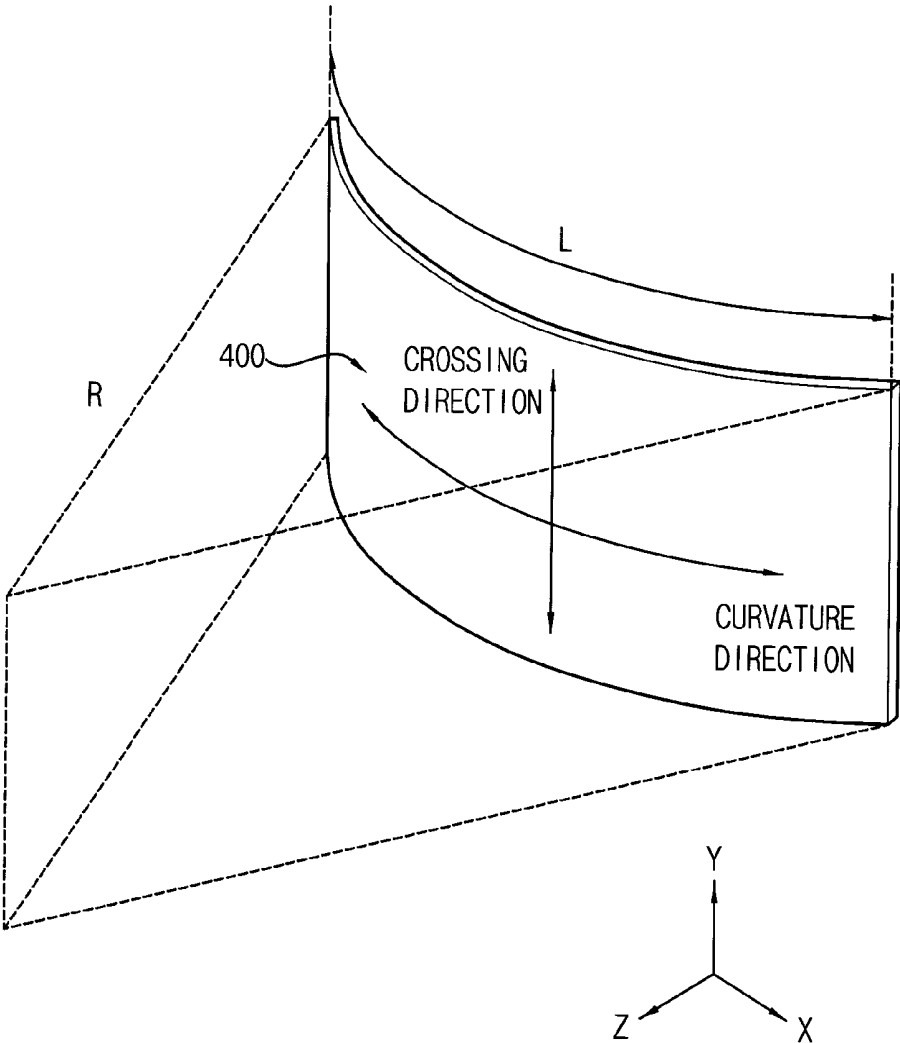

FIG. 9

400

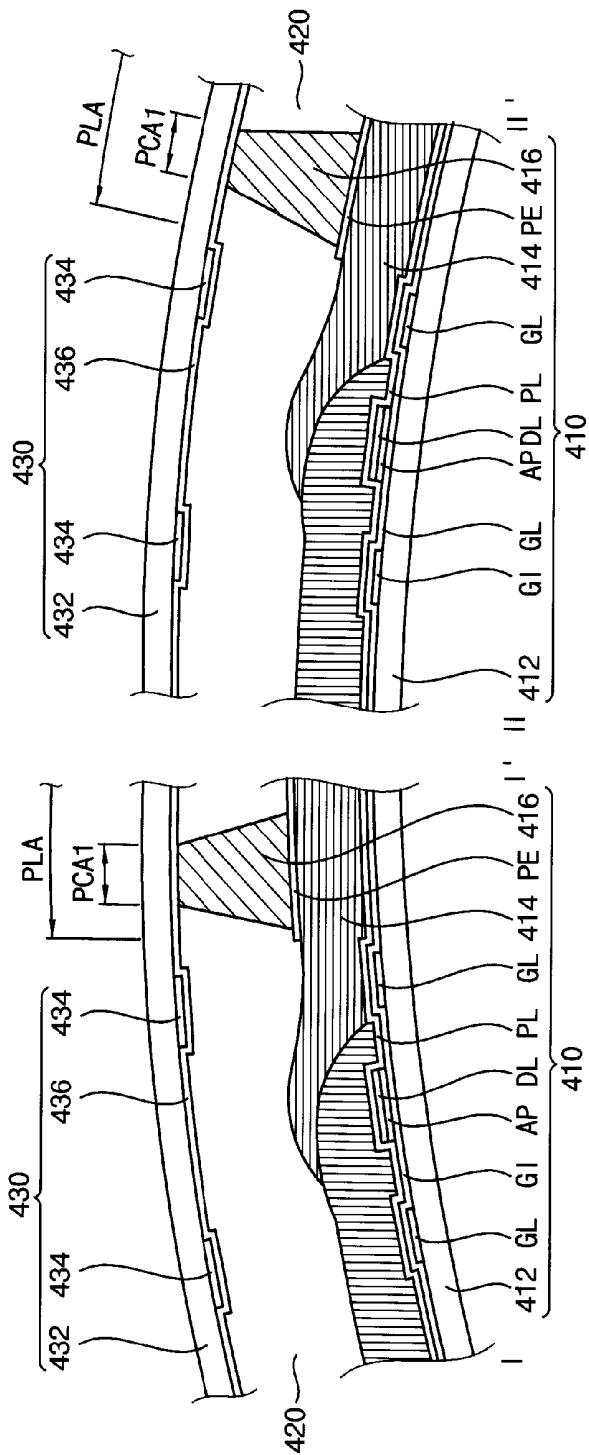

FIG. 10

500

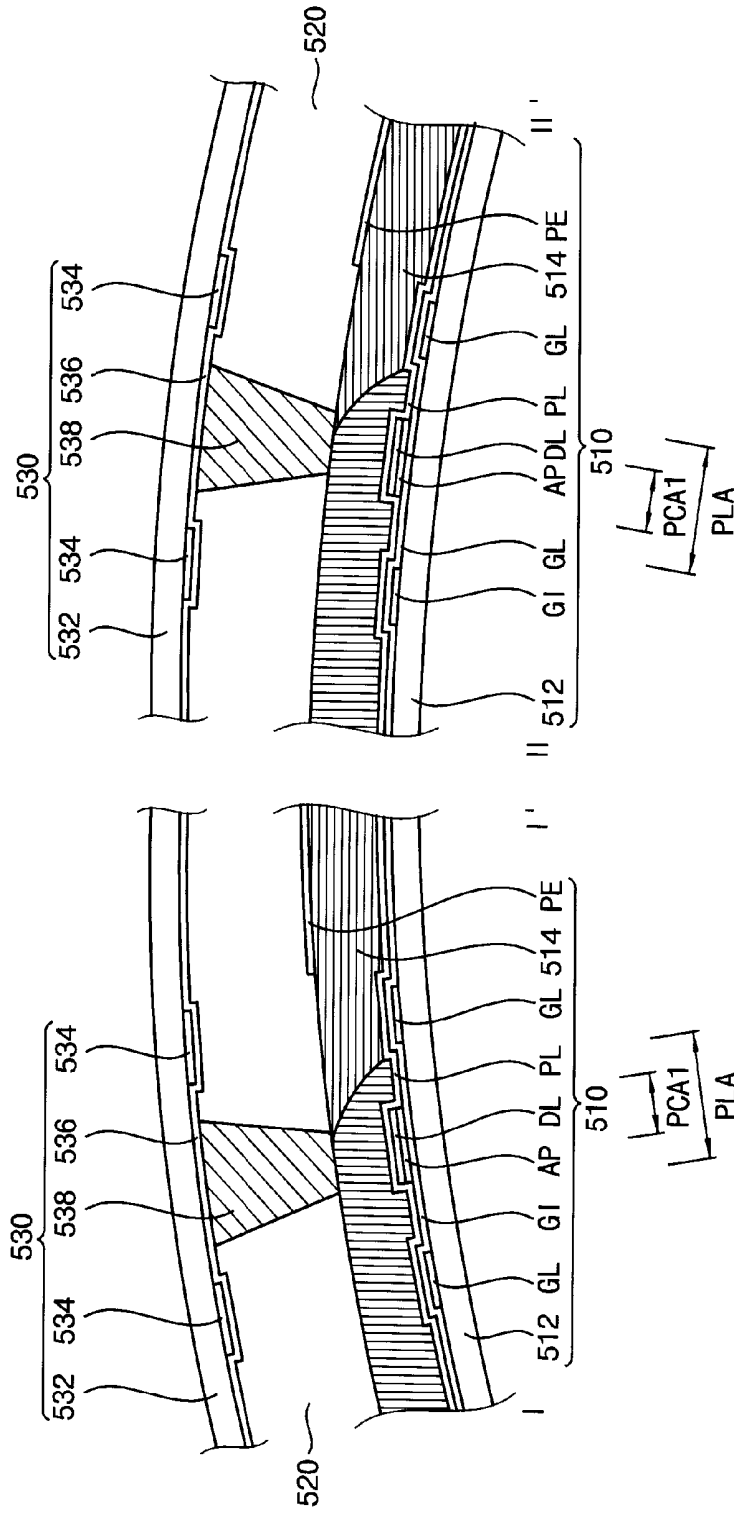
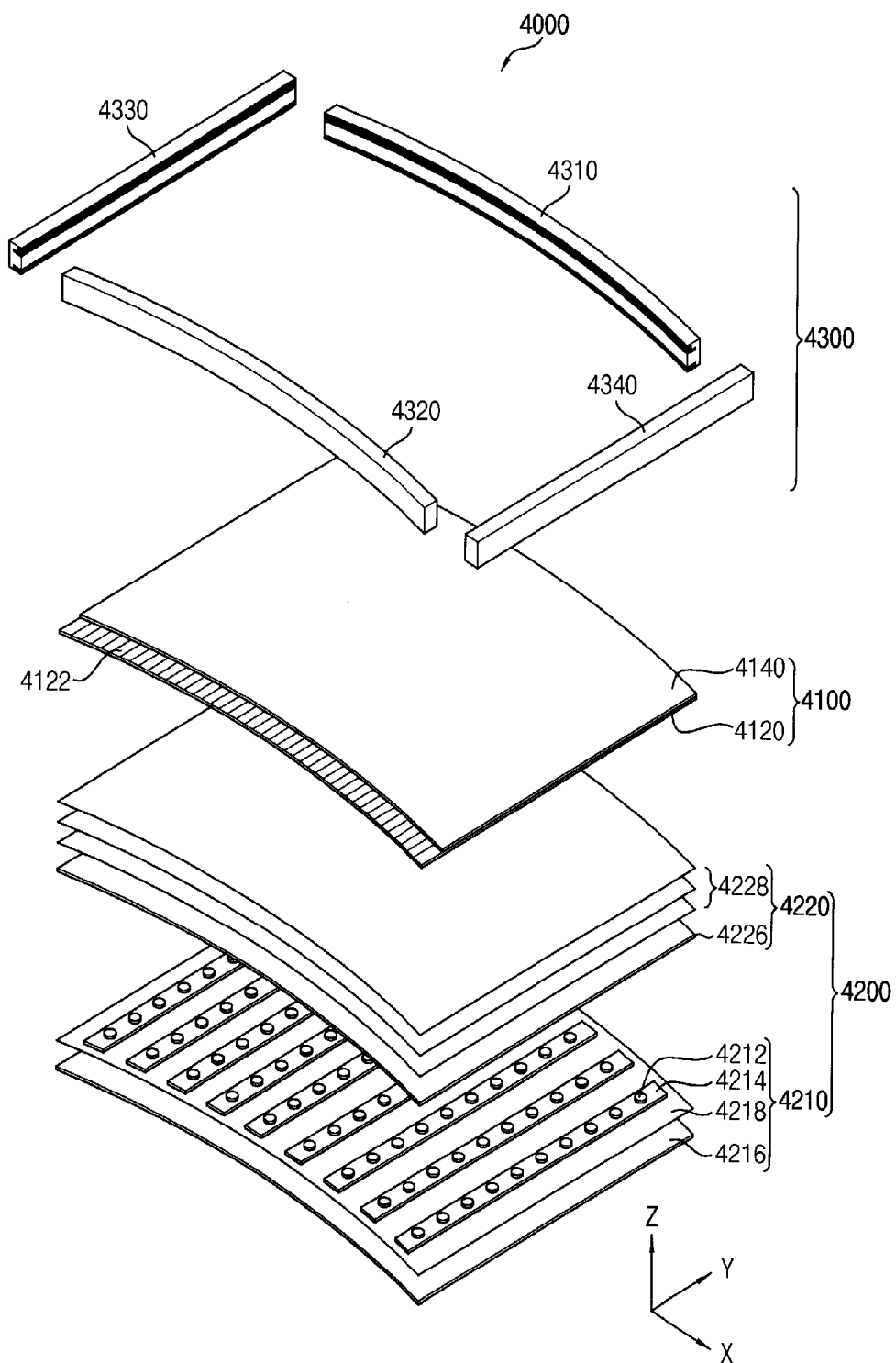

FIG. 11



## CURVED LIQUID CRYSTAL DISPLAY PANEL

### CROSS-REFERENCE TO RELATED APPLICATIONS

[0001] This application claims priority under 35 U.S.C. §119 to Korean Patent Application No. 10-2013-0130225, filed on Oct. 30, 2013 in the Korean Intellectual Property Office (KIPO), the contents of which application are herein incorporated by reference in their entirety.

### BACKGROUND

[0002] 1. Technical Field

[0003] The present disclosure of invention relates to a curved liquid crystal display (“LCD”) panel. More particularly, it relates to a curved LCD panel capable of enhancing a display quality.

[0004] 2. Discussion of Related Technology

[0005] In recent years, as the liquid crystal display device (“LCD”) has come to be popularly used as a display device for television receivers and other multi-user applications, the screens of such liquid crystal display devices have been trending towards becoming increasingly bigger. But a problem with such increasingly larger (e.g., wider) television LCD screens is that the quality of viewing experience changes substantially between when a centered user views the screen while focusing on the center portion of the screen and when the centered user focuses his/her view to the left or right edges of the wide display screen. The problem can be worse for a second user situated closer to the left or right edge of the wide display screen and trying to focus eyesight on the much further away (and more angled relative to the screen normal) opposite edge of the wide display screen.

[0006] Curved display screens have been proposed a solution to this problem. In this specification, the technical term “viewing angle” is used and is defined as the acute or right angle formed between the line of focusing sight of the viewer viewing the horizontally wide screen and a horizontal tangent line that is tangent to the curved spot on the screen where the user’s line of sight intersects with the screen surface. In other words, the “viewing angle” of a horizontally centered user who focuses on the center of the screen is the right angle (90 degrees) while the “viewing angle” of the same user when focusing on a right edge or a left edge is, for the case of an almost flat screen, an acute angle (less than 90 degrees). The difference in “viewing angle” between when the centered user views the center and when he/she focuses on the left/right edge is defined as, and is used herein as being the “viewing angle difference”. More specifically, if the “viewing angle” for the left or right edge is 60 degrees, then the “viewing angle difference” will be the complement of that, namely, 30 degrees. If sameness of viewing experience is desired under these terms, then the “viewing angle difference” should be reduced towards zero (0) degrees.

[0007] Furthermore, another problem with flat-type large-scale television LCD screens is that glare off the screens also increases. Both the side glare problem and the problem of difference in viewing angle can be corrected by curving the screen into a concave shape.

[0008] Uniformity of viewing experience as between on-center focus and towards-edge focus also depends on uniformity of thickness of the liquid crystal material in the respective portions the screen (e.g., the screen center and screen extreme left and right side edges). Typically, so-called, col-

umn spacers having a uniform cross-section over their respective heights (e.g., cylinder shaped) are formed on one of the upper and lower substrates of a LCD panel so as to maintain a uniform cell gap of a liquid crystal layer across the full width of the panel. In a case of a curved LCD panel having a color filter on array (“COA”) type where a color filter layer is formed on the lower substrate, a step variation can be generated due to how the consistent-in-cross-section column spacers engage as between the opposed inner surfaces of the upper and lower substrates, so that display defects of the LCD panel are generated as a function of the shapes and/or a positions of the column spacers.

[0009] In the case of curved LCD panels, display color defects such as bluish or yellowish color tinting can occur due to a misalignment between an upper substrate and a lower substrate. This is mainly because changes of cell gap are generated in panels structured to have same, consistent-in-cross-section column spacers formed everywhere on a COA type LCD panel.

[0010] It is to be understood that this background of the technology section is intended to provide useful background for understanding the here disclosed technology and as such, the technology background section may include ideas, concepts or recognitions that were not part of what was known or appreciated by those skilled in the pertinent art prior to corresponding invention dates of subject matter disclosed herein.

### SUMMARY

[0011] The present disclosure of invention provides a curved liquid crystal display (“LCD”) panel capable of preventing display characteristics from being decreased by removing display defects due to preliminary design misalignment between an upper substrate and a lower substrate where the misalignment is due to the LCD panel being curved.

[0012] According to one aspect of the present teachings, a curved LCD panel includes a first substrate, a liquid crystal layer and a second substrate. The first substrate includes a column spacer having a base portion anchored to and protruding from the first substrate. The second substrate includes a preliminary contact area corresponding to where an opposed and free contact making end of the column spacer is preliminarily designed to make contact assuming no curvature and where the preliminary contact area is part of a larger non-stepped area (e.g., a planarized area) which is dimensioned to account for misalignment of the free contact making end, the misalignment being due to curvature of the display panel. The second substrate is combined with the first substrate to receive the liquid crystal layer.

[0013] In an exemplary embodiment, the non-stepped area may be formed along a curvature direction of the curved LCD panel.

[0014] In an exemplary embodiment, a length of the non-stepped area may be in proportion to a size of the curved LCD panel and may be in inverse proportion to a curvature radius of the curved LCD panel.

[0015] In an exemplary embodiment, a length of the non-stepped area satisfies the following equation:

$$D \geq \frac{L \times T}{R} \times 0.1,$$

wherein, 'D' denotes a length of the planarized area, 'L' denotes a length of a panel in parallel with a curvature direction, 'T' denotes a thickness of a base substrate of the first substrate or a thickness of a base substrate of the second substrate, and 'R' denotes a curvature radius.

**[0016]** In an exemplary embodiment, the first substrate may include a lower substrate on which a plurality of switching elements is formed. Here, the second substrate may include a light-blocking layer formed in a stripes only type of arrangement in parallel with each other.

**[0017]** In this case, the light-blocking layer may be in parallel with gate lines respectively connected to corresponding switching elements.

**[0018]** In an exemplary embodiment, the first substrate may include a lower substrate on which a plurality of switching elements and a color filter layer covering the switching element are formed. In this case, the column spacer may be formed on and anchored to the color filter layer.

**[0019]** In an exemplary embodiment, the second substrate may include a lower substrate on which a plurality of switching elements is formed. In this case, the column spacer continues to be formed on and protruding from the first substrate.

**[0020]** In an exemplary embodiment, the second substrate may include a light-blocking layer formed in a stripes type in parallel with each other. In this case, the light-blocking layer may be in parallel with a gate line connected to the switching element.

**[0021]** In an exemplary embodiment, the second substrate may include a lower substrate on which a plurality of switching elements and a color filter layer covering the switching element are formed. In this case, the column spacer may be formed on the first substrate.

**[0022]** In an exemplary embodiment, the color filter layer may include a first color filter layer and a different second color filter layer. In this case, an overlapped portion of the first color filter layer and the second color filter layer may be planarized to define the non-stepped area.

**[0023]** In an exemplary embodiment, the curved LCD panel may have a concave shape.

**[0024]** In an exemplary embodiment, curved LCD panel may have a convex shape.

**[0025]** According to some exemplary embodiments of the present disclosure of invention, a planarized area surrounding a preliminary contact area corresponding to an upper surface of a column spacer is formed, so that it may prevent a cell gap from being varied due to a misalignment between a first substrate and a second substrate even through an LCD panel is curved. Thus, it may remove display defects due to a cell gap variation, thereby enhancing display characteristics.

#### BRIEF DESCRIPTION OF THE DRAWINGS

**[0026]** The above and other features and aspects of the present disclosure of invention will become more apparent by describing in detailed exemplary embodiments thereof with reference to the accompanying drawings, in which:

**[0027]** FIG. 1 is a perspective view schematically illustrating a curved liquid crystal display ("LCD") panel according to an exemplary embodiment of the present disclosure of invention;

**[0028]** FIG. 2A is a cross-sectional view schematically illustrating a column spacer of the curved LCD panel shown in FIG. 1 where the illustrated column spacer is not a consistent-in-cross-section column spacer;

**[0029]** FIG. 2B is a plan view schematically illustrating preliminary contact areas corresponding to the column spacer and a planarized area shown in FIG. 2A;

**[0030]** FIG. 3 is a graph schematically explaining a misalignment amount between an upper substrate and a lower substrate in accordance with a curvature per sizes of a curved LCD panel;

**[0031]** FIG. 4 is a plan view schematically explaining a unit pixel positioned at a left portion of the curved LCD panel and a unit pixel positioned at a right portion of the curved LCD panel shown in FIG. 1;

**[0032]** FIG. 5 is a cross-sectional view schematically illustrating an example of the curved LCD panel shown in FIG. 1;

**[0033]** FIG. 6 is a cross-sectional view schematically illustrating another example of concave curved LCD panel such as shown in FIG. 1;

**[0034]** FIG. 7 is an exploded perspective view schematically illustrating an example of a curved LCD device having the curved LCD panel shown in FIG. 1;

**[0035]** FIG. 8 is a perspective view schematically illustrating a curved LCD panel according to another exemplary embodiment;

**[0036]** FIG. 9 is a cross-sectional view schematically illustrating an example of the curved LCD panel shown in FIG. 8;

**[0037]** FIG. 10 is a cross-sectional view schematically illustrating another example of the curved LCD panel shown in FIG. 8; and

**[0038]** FIG. 11 is an exploded perspective view schematically illustrating an example of a curved LCD device having the curved LCD panel shown in FIG. 8.

#### DETAILED DESCRIPTION

**[0039]** Hereinafter, curved LCD panels according to the present disclosure of invention will be explained in detail with reference to the accompanying drawings.

**[0040]** FIG. 1 is a perspective view schematically illustrating a concave-wise curved liquid crystal display ("LCD") panel 100 according to an exemplary embodiment of the present disclosure. FIG. 2A is a cross-sectional view schematically illustrating a column spacer 114 of the curved LCD panel 100 shown in FIG. 1. FIG. 2B is a plan view schematically illustrating preliminary contact areas corresponding to the column spacer 114 and a planarized area shown in FIG. 2A.

**[0041]** Referring to FIGS. 1, 2A and 2B, a curved LCD panel 100 according to an exemplary embodiment of the present disclosure of invention starts off as being in a preliminarily flat condition and then it is bent from the middle out to its left and right edges so as to be concavely curved and to have a uniform curvature of radius R about a center spot when viewed in an X-Y plan view sense. The curvature radius R corresponding to the attained uniform curvature may be about 1,000 mm to about 9,000 mm.

**[0042]** The curved LCD panel 100 includes a first or "lower" substrate 110, a liquid crystal layer 120 and a second or "upper" substrate 130 combined with the lower/first substrate 110 and spaced apart therefrom so as to receive the liquid crystal layer 120 in between. For sake of consistency and the concave curving example of FIG. 1, the lower/first substrate 110 will be deemed to be further away from the centered viewer (and also further away from the center of curvature) while the "upper" second substrate 130 (higher up on the local Z-axis) will be deemed to be closer. The curvature radius R will be deemed to be measured from the center of

curvature to the top of the lower/first substrate **110** such that the illustrated “L” dimension is the width of the curved lower/first substrate **110** measured from end to end. As those skilled in the geometric arts will appreciate, the corresponding width of the curved “upper” second substrate **130** may be slightly smaller when measured from where the left side radius R intersects to where the right side radius R intersects. This is so because the arc length of a circular segment is a function of the swept angle (e.g., measured in radians) times the length of the effective radius, where for the case of the upper/second substrate **130** that effective radius R' is slightly smaller than the effective radius R for the lower/first substrate **110**. Accordingly, when the preliminarily flat structure is bent to achieve the illustrated curvature of FIG. 1, points on the upper/second substrate **130** (except for the center point) will shift slightly relative to corresponding on same-radial-line points on the lower/first substrate **110**. Although the amount of shift can be small, it nonetheless is greater than zero and can be consequential.

[0043] Referring to FIG. 2A, the first substrate **110** includes a first base substrate **112** and a column spacer **114** fixedly formed on and protruding upwardly (in the positive Z direction) from the first substrate **112** to the second **130** so as to maintain a desired cell gap of the liquid crystal layer **120**. The first base substrate **112** may have a transparent material such as a glass, a glass fiber reinforced plastic, etc.

[0044] The second substrate **130** includes a second base substrate **132** and, for sake of exemplary discussion here, a plurality of spaced apart stepped portions **134** and **136** separated from each other by a distance D and fixedly formed on the second base substrate **132**. The top of the frusto-conically shaped column spacer **114** may shift within the expanse (planarized area, non-stepped area) of the separation distance D as the two substrates (**110** and **130**) are brought into contact and both simultaneously bent to achieve the illustrated curvature of FIG. 1. The second base substrate **132** may have a transparent material such as a glass, a glass fiber reinforced plastic, etc. The illustrated stepped portions **134** and **136** may be protruding ones of various elements or various layers formed on the second substrate **130** and used for example to drive a display of the curved LCD panel **100**. When the top of the frusto-conically shaped column spacer **114** shifts during bending, it is desirable that it should not shift so much as to hit either one of the stepped portions **134** and **136** at the outer bounds of the non-stepped separation distance D. In an example, heights of the stepped portions **134** and **136** may be equal to each other. In another example, heights of the stepped portions **134** and **136** may be different from each other. In either case, the expanse of distance D is an unstepped one into which the narrower end of the frusto-conically shaped column spacer **114** makes contact either before bending or after bending and is an expanse within which the contacting area (CA) of the column spacer **114** may shift as a result of the bending. Hereinafter, the non-stepped separation distance D within which the narrower end of the column spacer **114** makes contact will also be referred to as a “planarized area” where, in the context of the present disclosure, the “planarized” portion of the phrase does not necessarily mean always flat, but rather one that would be flat if the substrate is considered as being in a nonbent preliminary state.

[0045] When the first substrate **110** is a TFT-array type lower substrate on which plural switching elements are formed, the second substrate **130** may be a common electrode type upper substrate on which a common electrode is some-

times formed. However, it is within the contemplation of the present disclosure that alternatively, the second substrate **130** is a TFT-array type substrate on which plural switching elements are formed and the first substrate **110** is a common electrode type, opposed substrate.

[0046] In accordance with the present disclosure, the second/upper substrate **130** is patterned to include a preliminary contact area PCA1 which corresponds to a location where an upper surface of the column spacer **114** would make contact if the first and second substrates are preliminarily each in a flat state, brought together as such and afterwards bent. Moreover, the second/upper substrate **130** is patterned to include a planarized area PLA of width D, centered on and surrounding the preliminary contact area PCA1. FIG. 2B shows the case where the preliminary contact area PCA1 is an area corresponding to an upper surface of the column spacer **114** designed in correspondence with a flat type LCD panel that is afterwards bent to become a curved type LCD panel.

[0047] When the preliminary contact area PCA1 corresponds with a center portion of a flat type (pre-bending) LCD panel, an upper surface of a column spacer **114** makes preliminary contact with the preliminary contact area PCA1 before the flat type LCD panel is bent to be concavely or convexly curved when viewed from an X-Y plan view perspective. The width D of the planarized area (PLA) is set to accommodate for an expected maximum shift of position (misalignment) away from the preliminary contact area PCA1 that the upper surface of a column spacer **114** will make as the substrates are bent in accordance with a predetermined curvature radius R.

[0048] When a preliminarily-designed as a flat LCD panel is re-purposed to be concavely curved when viewed from an X-Y plan sense, those of its column spacers **114** which are formed near the extreme right end of the LCD panel will have their landing spots in the PLA landing zone maximally shifted in a first direction (e.g., leftward) away from the referenced PCA1 portion to new position PCA2 while those of its column spacers **114** which are formed near the extreme left end will have their respective landing spots in the PLA landing zone maximally shifted in an opposed second direction (e.g., rightward) away from the referenced PCA1 portion and to new position identified by reference numeral PCA3. The planarized landing zone area PLA may be designed (in accordance with one embodiment) to accommodate for both shifts.

[0049] On the other hand, when a preliminarily flat type LCD panel is bent to be convexly curved (as opposed to concavely curved) when viewed from an X-Y plan view sense, column spacers **114** formed at the far right portion of the flat type LCD panel will be maximally shifted into the PCA3 portion, while column spacers **114** formed at the far left portion of the flat type LCD panel will be maximally shifted into the PCA2 position. However, since the planarized area PLA is dimensioned to handle misalignment shifts in either direction, the same design can be used for preliminarily flat type LCD panels that are to be bent to be either convexly curved or concavely curved.

[0050] The planarized area PLA is formed along a curved surface direction of a curved LCD panel. When the first surface **110** and the second surface **130** is combined with each other to form a curved LCD panel, the planarized area PLA is designed to provide leeway with margin of error for the maximal misalignment amount of the curved LCD panel. When the first and second substrates are bent from the middle out

(meaning the far ends can be moved while the middle stays in place during bending), then the misalignment amount is zero for the column spacer **114** located in the middle, in other words, those which correspond to a line shown as the crossing direction in FIG. 1 which line is substantially perpendicular to a curvature direction of the curved LCD panel. However, the misalignment amount increases to be progressively greater than zero for column spacers **114** disposed horizontally further and further away from the center portion of the curved LCD panel. Thus, it is designed that the planarized area PLA is greater than the maximum of the misalignment amount.

**[0051]** FIG. 3 is a graph schematically explaining the expected maximal misalignment amounts between an upper substrate and a lower substrate in accordance with a curvature radius (R) per different sizes (e.g., screen diagonal measures) of a curved LCD panel.

**[0052]** Referring to FIG. 3, the misalignment amount is greater when the curvature radius is made smaller, and the misalignment amount is relatively smaller as the curvature radius is made bigger. That is, each curved LCD panels having the different sizes has a misalignment amount that may be deemed to be exponentially decaying in accordance with an increasing of a curvature radius R.

**[0053]** For example, in a case of a 32-inch diagonal curved LCD panel, a misalignment amount is about 60  $\mu\text{m}$  when a curvature radius is about 1,000 mm, and a misalignment amount is about 26  $\mu\text{m}$  when a curvature radius is about 2,000 mm. Moreover, a misalignment amount is about 20  $\mu\text{m}$  when a curvature radius is about 3000 mm, and a misalignment amount is about 18  $\mu\text{m}$  when a curvature radius is about 4,000 mm. In this way, the maximal misalignment amount is exponentially decaying, so that the maximal misalignment amount is about 5  $\mu\text{m}$  when a curvature radius is about 9,000 mm.

**[0054]** In a case of a 55-inch curved LCD panel, a misalignment amount is about 100  $\mu\text{m}$  when a curvature radius is about 1,000 mm, and a misalignment amount is about 50  $\mu\text{m}$  when a curvature radius is about 2,000 mm. Moreover, a misalignment amount is about 30  $\mu\text{m}$  when a curvature radius is about 3000 mm, and a misalignment amount is about 25  $\mu\text{m}$  when a curvature radius is about 4,000 mm. In this way, a misalignment amount is exponentially decaying, so that a misalignment amount is about 6  $\mu\text{m}$  when the curvature radius (R) is about 9,000 mm.

**[0055]** In a case of a 95-inch curved LCD panel, a misalignment amount is about 220  $\mu\text{m}$  when a curvature radius is about 1,000 mm, and a misalignment amount is about 100  $\mu\text{m}$  when a curvature radius is about 2,000 mm. Moreover, a misalignment amount is about 65  $\mu\text{m}$  when a curvature radius is about 3000 mm, and a misalignment amount is about 40  $\mu\text{m}$  when a curvature radius is about 4,000 mm. In this way, a misalignment amount is exponentially decaying, so that a misalignment amount is about 15  $\mu\text{m}$  when the curvature radius is about 9,000 mm.

**[0056]** It may therefore be determined from the plots of FIG. 3 that the maximal misalignment amount is differently generated in accordance with the desired curvature radius (R) and the desired size (diagonal measure) of the curved LCD panel. Moreover, and although not shown in FIG. 3, It may be determined that the maximal misalignment amount is differently generated in accordance with a thickness of a base substrate of an upper substrate (e.g., the first base substrate **112** of the first substrate **110** shown in FIG. 2A) or a thickness of a base substrate of a lower substrate (e.g., the second base substrate **132** of the second substrate **130** shown in FIG. 2A).

**[0057]** In accordance with the present disclosure of invention, the substrate (e.g., the upper substrate **110**) which has the preliminary contact areas (PCNs) is patterned such that the corresponding planarized (meaning stepless) landing zone areas (PLA's) each have an S index greater than 0.1. In this case, the S index is defined by the following Equation 1.

$$S = \frac{R \times M}{L \times T} \quad \text{[Equation 1]}$$

**[0058]** Here, 'L' denotes a length of a curved LCD panel in parallel with a curvature direction, 'T' denotes a thickness of the first base substrate **112** of the first substrate **110** or a thickness of the second base substrate **132** of the second substrate **130**. 'R' denotes a curvature radius, and 'M' denotes a misalignment amount of an upper substrate and a lower substrate. In this case, the measurement units of L, T, R and M are all in millimeters (mm).

**[0059]** When the S index is calculated per sizes of a curved LCD panel and curvature radius of a curved LCD panel, it produces the following Table 1. Here, it was calculated that a thickness of a base substrate is about 0.7 mm.

TABLE 1

Curvature radius(mm)	32"	40"	46"	55"	70"	85"	95"
1,000	0.11	0.11	0.11	0.11	0.13	0.13	0.14
2,000	0.11	0.11	0.11	0.11	0.12	0.13	0.13
3,000	0.11	0.11	0.11	0.11	0.11	0.11	0.12
4,000	0.11	0.11	0.11	0.11	0.11	0.11	0.11
5,000	0.11	0.11	0.11	0.11	0.11	0.11	0.11
6,000	0.11	0.11	0.11	0.11	0.11	0.11	0.11
7,000	0.11	0.11	0.11	0.11	0.11	0.11	0.10
8,000	0.11	0.11	0.11	0.11	0.11	0.11	0.10
9,000	0.11	0.11	0.11	0.11	0.11	0.10	0.10

**[0060]** Referring to Table 1, when a 32-inch LCD panel is curved to have a curvature radius R of about 1000 mm, the corresponding S index was calculated as about 0.11. Moreover, when a 32-inch LCD panel is curved to have curvature radiuses of about 1000 mm, about 2000 mm, about 3000 mm, about 4000 mm, about 5000 mm, about 6000 mm, about 7000 mm, about 8000 mm and about 9000 mm, respectively, S index was calculated as about 0.11. Similarly, when a 32-inch LCD panel, 40-inch LCD panel, a 46-inch LCD panel, a 55-inch LCD panel, a 70-inch LCD panel, a 85-inch LCD panel and a 95-inch LCD panel are respectively curved to have curvature radiuses of about 1000 mm to about 9000 mm, it is determined that S index is greater than or equal to about 0.10.

**[0061]** Thus, when it is desired that the planarized area PLA have an S index greater than 0.1, a column spacer is shifted within the planarized area PLA even though an LCD panel is curved so that a cell gap of liquid crystals may be maintained.

**[0062]** Moreover, it may prevented display defects such as bluish or yellowish due to a misalignment between an upper substrate and a lower substrate from being generated.

**[0063]** The planarized area PLA is formed along a curvature direction of the curved LCD panel **100**. A length of the planarized area PLA is in proportion to a size of the curved LCD panel **100** and is in inverse proportion to a curvature radius of the curved LCD panel **100**. For example, a margin

for error is included if the designed length of the planarized area PLA satisfies the following Equation 2.

$$D \geq \frac{L \times T}{R} \times 0.1 \quad [\text{Equation 2}]$$

[0064] Here, 'D' denotes a designed length of the planarized area PLA, 'L' denotes a length of a panel in parallel with a curvature direction, 'T' denotes a thickness of the first base substrate **112** of the first substrate **110** or a thickness of the second base substrate **132** of the second substrate **130**, and 'R' denotes a curvature radius.

[0065] FIG. 4 is a top plan view schematically showing two of repeated unit pixel cells, one positioned at a left portion of the curved LCD panel **100** and the other positioned at a right portion of the curved LCD panel **100** shown in FIG. 1.

[0066] Referring to FIG. 4, a lower substrate of the curved LCD panel **100** has integrally formed thereon, a plurality of gate lines GL, a plurality of data lines DL crossing the gate lines GL, a plurality of switching elements SW connected to the gate line GL and the data line DL, and a plurality of pixel electrodes PE respectively connected to the switching elements SW.

[0067] The gate lines GL extend longitudinally substantially in an X-axis direction and are arranged to be spaced apart substantially along a Y-axis direction. Each of the gate lines GL provides the switching element SW with a gate signal to turn on the switching element SW. The gate lines GL may include a material such as aluminum (Al), molybdenum (Mo), neodymium (Nd), chromium (Cr), tantalum (Ta), titanium (Ti), tungsten (W), silver (Ag), etc., or a metal alloy thereof.

[0068] The data lines DL extend substantially in the Y-axis direction and arranged to be spaced apart substantially along the X-axis direction. The data lines DL provide the switching elements SW with a data signal. In such an embodiment, when the switching elements SW are turned on, the data signal is transmitted to the pixel electrodes PE. The data lines DL may include at least one of aluminum (Al), aluminum (Al) alloy, molybdenum (Mo), molybdenum (Mo) alloy, chromium (Cr), chromium (Cr) alloy, tantalum (Ta), tantalum (Ta) alloy titanium (Ti), titanium (Ti) alloy tungsten (W), tungsten (W) alloy, copper (Cu), copper (Cu) alloy, silver (Ag) and silver (Ag) alloy, for example.

[0069] Each of the switching elements SW includes a control terminal (hereinafter, a gate electrode GE), a semiconductive active layer AP, an input terminal (hereinafter, a source electrode SE) and an output terminal (hereinafter, a drain electrode DE), which are respectively connected to the gate line GL and the data line DL. In an exemplary embodiment, each of the switching elements SW may be a thin-film transistor ("TFT"). In an exemplary embodiment, the switching elements SW are described as TFTs having a bottom gate structure on which a gate electrode is disposed below a source electrode and a drain electrode; however, it is not limited thereto. In one alternative exemplary embodiment, for example, the switching elements SW may be TFTs having an on-top gate structure on which a gate electrode is disposed above the corresponding source and drain electrodes.

[0070] After a semiconductive metal oxide or polysilicon doped with impurities at a high concentration is deposited, the gate electrodes GE may be provided, e.g., formed, by pattern-

ing the metal oxide or the poly-silicon through a photolithography process and etching process using a mask.

[0071] The active layer AP may include amorphous silicon or poly-silicon or a semiconductive metal oxide. In the case of poly-silicon, the latter may be formed by crystallizing deposited amorphous silicon using a laser, for example.

[0072] A gate insulation layer GIL is provided on the gate electrodes GE and the gate lines GL. The gate insulation layer GIL may include a silicon oxide (SiO<sub>x</sub>), a silicon nitride (SiN<sub>x</sub>) or a laminated combination of both.

[0073] A pixel electrode PE is electrically connected to a drain electrode DE of a switching element SW through a contact hole CNT formed through an organic layer OL including an organic material such as a polyimide ("PI") resin, a polyethersulfone ("PES") resin, a polyethylene-terephthalate ("PET") resin, a polyarylate ("PAR") resin and an acrylate resin, for example. The pixel electrode PE receives a data signal provided from the switching element SW. In an exemplary embodiment, the pixel electrode PE may be formed by sputter depositing an optically transparent and electrically conductive material, such as indium tin oxide ("ITO") and indium zinc oxide ("IZO"), for example, on the gate insulation layer GIL, and then by patterning the optically transparent and electrically conductive material through a photolithography process and etching process using a mask.

[0074] FIG. 5 is a cross-sectional view schematically illustrating an example of the curved LCD panel **100** shown in FIG. 1. That is, it is shown that a column spacer is fixedly formed to have a wider base portion anchored on a lower substrate **210** on which a color filter layer is formed and a light-blocking layer is removed from an upper substrate. In such an embodiment, cross-sectional views taken along a line I-I' and a line II-II' in FIG. 4 are shown.

[0075] Referring to FIG. 5, a curved LCD panel **200** according to the illustrated example includes a lower substrate **210**, a liquid crystal layer **220** and an upper substrate **230** to be concavely curved to have a uniform curvature when viewed from an X-Y plan view sense.

[0076] The lower substrate **210** includes a first base substrate **212** which is concavely curved to have a uniform curvature. A plurality of gate lines GL, a gate insulation layer GI, an active layer AP, a plurality of data lines DL and a plurality of switching elements (not shown) connected to the gate lines GL and the data lines DL, respectively, are formed on the first base substrate **212**. A passivation layer PL is formed on the gate insulation layer GI and the switching element. A color filter layer **214** is formed on the passivation layer PL. A pixel electrode PE connected to a drain electrode of the switching element is formed on the color filter layer **214**. A column spacer **216** is formed on a portion of the pixel electrode layer PE. Alternatively, the column spacer **216** may be formed directly on the color filter layer **214**. Moreover, the column spacer **216** may be formed partly on a portion of the pixel electrode PE and partly in direct contact with an adjacent portion of the color filter layer **214**.

[0077] The upper substrate **230** is combined (joined together) with the lower substrate **210** to receive the liquid crystal layer **220** in between. The upper substrate **230** includes a second base substrate **232** which is concavely curved to have a uniform curvature and a patterned light-blocking layer **234** which is formed on the second base substrate **232** in correspondence with a gate line GL of the lower

substrate **210**. A common electrode layer **236** is formed on the second base substrate **232** and the patterned light-blocking layer **234**.

[0078] The upper substrate **230** is patterned so as to include a non-stepped, contact landing area PLA which includes at its center, the preliminary contact area PCA1 corresponding to where, if the panel were not bent, an upper surface area of the column spacer **216** would be expected to come into contact with the planarized area PLA. In other words, no stepped portions are present either within the preliminary contact area PCA1 or within the rest of the planarized landing zone area PLA.

[0079] In the present exemplary embodiment, the light-blocking layer is patterned so as to be absent in vertically extending areas corresponding to the vertically extending data lines DL of the lower substrate **210** and instead light blocking is provided thereat by overlap of two or more different colored color filter layers **214**. Thus, the light-blocking layer is formed in a stripe type pattern in parallel with the gate lines GL rather than in a matrix pattern that further extends vertically above the data lines (DL) as well. Therefore, since the upper substrate **230** has fewer stepped portions (e.g., **234**), larger non-stepped areas are made available to serve as stepless contact landing zones (PLA's) for the corresponding column spacers **216**.

[0080] FIG. 6 is a cross-sectional view schematically illustrating another example of the curved LCD panel shown in FIG. 1. Here the wider bases of the column spacers **338** are fixedly attached to the upper substrate **330** and the contact landing zones (PLA's) are formed as stepless features on the lower substrate **310**. That is, it is shown that a column spacer is formed to make contact on a lower substrate on which a color filter layer is formed and a light-blocking layer is removed in the corresponding area of the upper substrate. In such an embodiment, cross-sectional views taken along a line I-I' and a line II-II' in FIG. 4 are shown.

[0081] Referring to FIG. 6, a curved LCD panel **300** includes a lower substrate **310**, a liquid crystal layer **320** and an upper substrate **330** to be concavely curved to have a uniform curvature when viewed from an X-Y plan view sense.

[0082] The lower substrate **310** includes a first base substrate **312** which is concavely curved to have a uniform curvature. A plurality of gate lines GL, a gate insulation layer GI, an activation layer AP, a plurality of data lines DL and a plurality of switching elements (not shown) connected to the gate lines GL and the data lines DL, respectively, are formed on the first base substrate **312**. A passivation layer PL is formed on the gate insulation layer GI and the switching element. A color filter layer **314** is formed on the passivation layer PL. A pixel electrode PE connected to a drain electrode of the switching element is formed on the color filter layer **314**.

[0083] In the present exemplary embodiment, the overlapped different colors portion of the color filters layer **314** is planarized so as to define a stepless landing zone region PLA. The color filter layer **314** may include a first color filter transmitting a first color light and a second color filter transmitting a second color light. Conventionally, since a first color filter is partially formed on a pixel area and then a second color filter is formed thereon, a height of an overlapped portion between the first color filter and the second color filter is higher than a height of the first color filter taken alone or a height of the second color filter taken alone thereby

defining a stepped feature. However, in the present exemplary embodiment, an overlapped portion of the color filters layer **314** is planarized to define a stepless preliminary contact area PCA1 disposed within the rest of the planarized landing zone area PLA. In the present exemplary embodiment, a height of the preliminary contact area PCA1 is substantially equal to that of the planarized area PLA. Thus, a stepped portion does not exist in the preliminary contact area PCA1 or in the rest of the planarized area PLA.

[0084] The upper substrate **330** is combined with the lower substrate **310** to receive the liquid crystal layer **320** therebetween. The upper substrate **330** includes a concavely curved second base substrate **332** and a light-blocking layer **334** formed in correspondence with a gate lines GL of the lower substrate **310**. A common electrode layer **336** is formed to cover the second base substrate **332** and the light-blocking layer **334**. A column spacer **338** is fixedly formed on and protruding downwardly from the common electrode layer **336**. In the present exemplary embodiment, the column spacer **338** is formed on an area which corresponds to a planarized area PLA defined on the lower substrate **310**.

[0085] In the present exemplary embodiment, a light-blocking layer **334** does not exist on an area corresponding to the data lines DL of the lower substrate **310**. Thus, the light-blocking layer **334** is formed in a stripe type in parallel with the gate lines GL.

[0086] FIG. 7 is an exploded perspective view schematically illustrating an example of a curved LCD device having the curved LCD panel shown in FIG. 1.

[0087] Referring to FIGS. 1 and 7, a curved LCD device **1000** includes a curved LCD panel **1100**, a backlight unit **1200** and a concavely curved frame **1300** that is concavely curved to have a uniform curvature matching that of the curved LCD panel **1100**, where both curvatures are those as viewed in an X-Y plan view sense. A curvature radius corresponding to the curvature may be about 1,000 mm to about 9,000 mm.

[0088] The curved LCD panel **1100** may have a curved shape of a uniform curvature when viewed from an X-Y plan view sense. In the present exemplary embodiment, the curved LCD panel **1100** may include a lower substrate **1120**, an upper substrate **1140** spaced apart from and facing the lower substrate **1120**, and a liquid crystal layer interposed between the lower substrate **1120** and the upper substrate **1140**. A size of the upper substrate **1140** is substantially smaller than that of the lower substrate **1120**. Thus, an area of the lower substrate not covered by the upper substrate **1140** is exposed. A pad part **1122** is formed on an exposed area of the lower substrate **1120**.

[0089] The curved LCD panel **1100** may be curved before the curved LCD panel **1100** is inserted into the concavely curved frame **1300**. Alternatively, the curved LCD panel **1100** may be bent to be curved after a flexible version of the to-be curved LCD panel **1100** is inserted into the previously concavely curved frame **1300**. For one example, when the curved LCD panel **1100** has a flexible type, the curved LCD panel **1100** may be curved after the curved LCD panel **1100** is inserted into the concavely curved frame **1300**. For another example, when the curved LCD panel **1100** has a ridge type, the curved LCD panel **1100** may be manufactured to have a curved shape of a predetermined curvature before the curved LCD panel **1100** is inserted into the concavely curved frame **1300**.

**[0090]** The curved LCD panel **1100** may have a curved shape by various manufacturing methods. For example, a flat display panel is disposed between a first curved mold of a convex shape and a second curved mold of a concave shape facing the first curved mold, and then the curved version of the LCD panel **1100** may be formed as such through use of a curing heat treatment and/or a pressing treatment. In this case, a bottom surface of a lower substrate of the flat display panel is disposed to contact with the first curved mold.

**[0091]** The lower substrate **1120** is a substrate on which TFTs that are switching elements are formed in a matrix arrangement. In the present exemplary embodiment, the lower substrate **1120** has a curved shape of uniform curvature. Each TFT has a source terminal connected to a data line, a gate terminal connected to a gate line, and a drain terminal connected to a pixel electrode of a transparent conductive material. A data pad part **1122** extended from the data line is disposed on a non-display area of the lower substrate **1120**. Alternatively, a gate pad part extended from the gate line may be further disposed on the non-display area of the lower substrate **1120**.

**[0092]** The upper substrate **1140** is disposed to face the lower substrate **1120**. The upper substrate **1140** includes a red pixel, a green pixel and a blue pixel that are formed to realize colors. In the present exemplary embodiment, the upper substrate **1140** has a curved shape of uniform curvature. A common electrode is formed on the upper substrate **1140**, which is opposite to the pixel electrode of the lower substrate **1120**. The common electrode includes an optically transparent and electrically conductive material (e.g., ITO or IZO).

**[0093]** Alternatively, the curved LCD panel **1100** may include a lower substrate on which color filters are formed and an opposition substrate on which a common electrode is formed to face the lower substrate.

**[0094]** When power is applied to a gate terminal of the TFT and the TFT is turned on, an electric field is generated between the pixel electrode and the common electrode. The electric field varies an aligning angle of the liquid crystal molecules interposed between the lower substrate **1120** and the upper substrate **1140**. Thus, a light transmittance of the liquid crystal layer is varied in accordance with the variation of the aligning angle of the liquid crystal, so a desired image may be obtained.

**[0095]** The curved LCD panel **1100** may include a first polarization film (not shown) disposed below the lower substrate **1120** and a second polarization film (not shown) disposed on the upper substrate **1140**. The first polarization film includes a light transmitting axis of a first direction to polarize lights in a first direction. The second polarization film includes a light transmitting axis of a different second direction to polarize lights in a second direction. For example, the light transmitting axis of the first polarization film may be perpendicular to the light transmitting axis of the second polarization film.

**[0096]** The backlight unit **1200** is disposed at a rear surface of the curved LCD panel **1100** to provide lights to the curved LCD panel **1100**. In the present exemplary embodiment, the backlight unit **1200** may have a curved shape which is curved in accordance with a curvature of the curved LCD panel **1100**. In the present exemplary embodiment, a curvature radius of the backlight unit **1200** may be about 1,000 mm to about 9,000 mm. In the present exemplary embodiment, when the curved LCD panel **1100** has a curvature radius of one of about 1,000 mm to about 4,000 mm, the backlight unit **1200** may

have a curvature radius substantially greater than a curvature radius of the curved LCD panel **1100**. For example, when the curved LCD panel **1100** has a curvature radius of about 7,000 mm, the backlight unit **1200** may have a curvature radius substantially greater than about 7,000 mm and substantially smaller than about 9,000 mm.

**[0097]** The backlight unit **1200** includes a light source assembly **1210** populated by light emitting sources and an optical assembly **1220** configured for enhancing light characteristics emitted from the light source assembly **1210**. In the present exemplary embodiment, a curvature radius of the optical assembly **1220** may be substantially greater than a curvature radius of the curved LCD panel **1100**, and may be substantially smaller than a curvature radius of the light source assembly **1210**.

**[0098]** The light source assembly **1210** includes a plurality of light-emitting diode ("LED") packages **1212** configured for emitting lights and a printed circuit board **1214** on which the LED packages **1212** are mounted. A signal wiring (not shown) for providing the LED packages **1212** with driving voltages, is formed on the printed circuit board **1214**. The light source assembly **1210** may be disposed in correspondence with a direction parallel with a long side of the curved LCD panel **1100**. Alternatively, the light source assembly **1210** may be disposed in correspondence with a direction parallel with a short side of the curved LCD panel **1100**.

**[0099]** In the present exemplary embodiment, a distance between the LED packages **1212** and the curved LCD panel **1100** is substantially uniform.

**[0100]** Conventionally, a flat display panel is curved to be a curved LCD panel **1100** having a concave shape. In this case, an upper substrate **1140** is compressed to induce a buckling (plastic deformation) phenomenon. When the buckling phenomenon is generated, a cell gap of a liquid crystal layer may be increased in correspondence with a corresponding area. When a cell gap of a liquid crystal layer is increased in correspondence with a specific portion of a curved LCD panel, a blue transmittance ratio is decreased rather than another portion of the curved LCD panel so that yellowish tinting may be generated.

**[0101]** Thus, in the present exemplary embodiment, in order to prevent a blue transmittance ratio inducing the yellowish tinting from being increased, it may vary a disposing or a structure of the LED packages **1212**. For example, when viewed from an X-Y plan sense of the curved LCD panel **1100**, a light amount of blue, which are emitted from the LED packages **1212** disposed on a middle area between a central portion parallel with Y-axis and an edge portion parallel with Y-axis, may be increased. For one example, it may increase the number of blue LEDs rather relative to the number of red LEDs or the number of green LEDs, thereby increasing a light amount in the blue portion of the spectrum. For another example, it may increase a voltage provided to the blue LED's as compared to that provided to the red LED's and/or the voltage provided to the green LED's, thereby increasing a light amount of blue portion of the spectrum.

**[0102]** The light source assembly **1210** may further include a bottom plate **1216** and a reflection sheet **1218**.

**[0103]** The bottom plate **1216** has a curved shape of a uniform curvature to secure the light source assembly **1210**. In the present exemplary embodiment, the bottom plate **1216** secures printed circuit boards **1214** having LED packages **1212** mounted thereon. In the present exemplary embodiment, the bottom plate **1216** may have a curved shape by

various manufacturing methods. For example, a flat bottom plate is disposed between a first curved mold of a convex shape and a second curved mold of a concave shape facing the first curved mold, and then the bottom plate **1216** may be manufactured through a heat treatment and a pressing treatment. In this case, a bottom surface of the flat bottom plate is disposed to contact with the first curved mold.

[0104] The reflection sheet **1218** is disposed on the bottom plate **1216** and is disposed below the light source assembly **1210** to reflect lights incident from the light source assembly **1210** toward the diffusion plate **1226**.

[0105] The optical assembly **1220** may include a diffusion plate **1226** and optical sheets **1228**.

[0106] The diffusion plate **1226** has a curved shape of uniform curvature. The diffusion plate **1226** diffuses lights emitted from the light source assembly **1210** or lights reflected by the reflection sheet **1218** to provide the optical sheets **1228** with the diffused lights. In the present exemplary embodiment, the diffusion plate **1226** may have a curved shape by various manufacturing methods. For example, a flat diffusion plate is disposed between a first curved mold of a concave shape and a second curved mold of a convex shape facing the first curved mold, and then the diffusion plate **1226** may be manufactured through a heat treatment and/or a pressing treatment. In this case, a bottom surface of the flat bottom plate is disposed to contact with the first curved mold.

[0107] The optical sheets **1228** are disposed on the diffusion plate **1226** to increase efficiency of lights incident from the diffusion plate **1226**. The optical sheets **1228** may include a diffusion sheet again diffusing lights diffused by the diffusion plate **1226** and a prism sheet condensing the lights diffused by the diffusion sheet. For one example, the prism sheet may include a vertical prism sheet condensing lights in a vertical direction and a horizontal prism sheet condensing lights in a horizontal direction.

[0108] The concavely curved frame **1300** includes an upper frame part **1310**, a lower frame part **1320**, a left frame part **1330** and a right frame part **1340** to secure the curved LCD panel **1100** and the backlight unit **1200** to secure the curved LCD panel **1100** and the backlight unit **1200**. The concavely curved frame **1300** has a curved shape of uniform curvature.

[0109] FIG. 8 is a perspective view schematically illustrating a curved LCD panel according to another exemplary embodiment of the present invention.

[0110] Referring to FIG. 8, the curved LCD panel **400** is convexly curved to have a uniform curvature when viewed from an X-Y plan sense. A curvature radius corresponding to the curvature is about 1,000 mm to about 9,000 mm. The curved LCD panel **400** shown in FIG. 8 is substantially the same as the curved LCD panel **100** shown in FIG. 1 except for at least that the curved LCD panel **400** is convexly curved, and thus any repetitive detailed explanation may hereinafter be omitted.

[0111] FIG. 9 is a cross-sectional view schematically illustrating an example of the curved LCD panel shown in FIG. 8. That is, it is shown that a column spacer **416** is formed to have its base anchored on a lower substrate on which a color filter layer is formed and a light-blocking layer portion is removed from an upper substrate. For convenience of description, an area corresponding to a left portion of a curved LCD panel and an area corresponding to a right portion of the curved LCD panel are shown in FIG. 9.

[0112] Referring to FIG. 9, a curved LCD panel **400** includes a lower substrate **410**, a liquid crystal layer **420** and

an upper substrate **430**. The LCD panel **400** is convexly curved to have a uniform curvature when viewed from an X-Y plan sense.

[0113] The lower substrate **410** includes a first base substrate **412** which is convexly curved to have a uniform curvature. A plurality of gate lines GL, a gate insulation layer GI, an active layer AP, a plurality of data lines DL and a plurality of switching elements (not shown) connected to the gate lines GL and the data lines DL, respectively, are formed on the first base substrate **412**. A passivation layer PL is formed on the gate insulation layer GI and the switching element. A color filter layer **414** is formed on the passivation layer PL. A pixel electrode PE connected to a drain electrode (not shown) of the switching element is formed on the color filter layer **414**. The column spacer **416** may be formed on the color filter layer **414**. Moreover, the column spacer **416** may be formed to anchor directly on a portion of the pixel electrode PE and/or on a portion of the color filter layer **414**.

[0114] The upper substrate **430** is combined with the lower substrate **410** to receive the liquid crystal layer **420** therebetween. The upper substrate **430** includes a second base substrate **432** which is convexly curved to have a uniform curvature and a light-blocking layer **434** which is formed on the second base substrate **432** in correspondence with a gate line GL of the lower substrate **410**. A common electrode layer **436** is formed on the second base substrate **432** and the light-blocking layer **434**.

[0115] The upper substrate **430** is patterned to include a preliminary contact area PCA1 corresponding to an upper contact surface of the column spacer **416** and a planarized area PLA containing the preliminary contact area PCA1. In the present exemplary embodiment, a height of the preliminary contact area PCA1 is substantially equal to that of the planarized area PLA. Thus, a stepped portion does not exist on the preliminary contact area PCA1 or the rest of the planarized area PLA.

[0116] In the present exemplary embodiment, the light-blocking layer is removed from an area corresponding to the data line DL of the lower substrate **410**. Thus, the light-blocking layer is formed just in a striped type arrangement in parallel with the gate lines GL.

[0117] FIG. 10 is a cross-sectional view schematically illustrating another example of the curved LCD panel shown in FIG. 8. For example, it is shown that a column spacer is formed to have its base portion anchored to the upper substrate and its contact portion disposed to make contact with an overlapped colors portion of the lower substrate where the overlapped colors portion on the lower substrate is planarized. For convenience of description, an area corresponding to a left portion of a curved LCD panel and an area corresponding to a right portion of the curved LCD panel are shown in FIG. 10.

[0118] Referring to FIG. 10, a curved LCD panel **500** includes a lower substrate **510**, a liquid crystal layer **520** and an upper substrate **530**. The LCD panel **500** is convexly curved to have a uniform curvature when viewed from an X-Y plan.

[0119] The lower substrate **510** includes a first base substrate **512** which is convexly curved to have a uniform curvature. A plurality of gate lines GL, a gate insulation layer GI, an active layer AP, a plurality data lines DL and a plurality switching elements (not shown) connected to the gate lines GL and the data lines DL, respectively, are formed on the first base substrate **512**. A passivation layer PL is formed on the

gate insulation layer GI and the switching element. A multi-colored color filters layer 514 is formed on the passivation layer PL. A pixel electrode PE connected to a drain electrode (not shown) of the switching element is formed on the color filter layer 514.

[0120] In the present exemplary embodiment, an overlapped portion of two or more of different colors of the color filters layer 314 is planarized. The color filter layer 314 may include a first color filter transmitting a first color light and a different second color filter transmitting a second color light. Conventionally, since a first color filter is partially formed on a pixel area and then a second color filter is formed thereon, a height of an overlapped portion between the first color filter and the second color filter is substantially higher than (and thus stepped relative to) a height of the first color filter alone or a height of the second color filter taken alone. However, in the present exemplary embodiment, an overlapped portion of the color filter layer 314 is planarized to define a preliminary contact area PCA1 and a remainder of the contact landing zone or planarized area PLA surrounding the preliminary contact area PCA1. In the present exemplary embodiment, a height of the preliminary contact area PCA1 is substantially equal to that of the planarized area PLA. Thus, a stepped portion does not exist on the preliminary contact area PCA1 and the planarized area PLA.

[0121] The upper substrate 530 is combined with the lower substrate 510 to receive the liquid crystal layer 520 therebetween. The upper substrate 530 includes a second base substrate 532 which is convexly curved to have a uniform curvature and a light-blocking layer 534 which is formed on the second base substrate 532 in correspondence with a gate line GL of the lower substrate 510. A common electrode layer 536 is formed to cover the second base substrate 532 and the light-blocking layer 534. A column spacer 538 is formed to have its base end anchored on the common electrode layer 536. The column spacer 538 is formed to have its opposed contact-making end disposed in correspondence with a planarized area PLA defined on the lower substrate 510.

[0122] In the present exemplary embodiment, a light-blocking layer 534 does not exist on an area corresponding to the data lines DL of the lower substrate 510. Thus, the light-blocking layer 534 is formed just in a stripes type arrangement in parallel with the gate lines GL.

[0123] FIG. 11 is an exploded perspective view schematically illustrating an example of a curved LCD device 4000 having the curved LCD panel shown in FIG. 8.

[0124] Referring to FIGS. 8 and 11, a curved LCD device 4000 includes a curved LCD panel 4100, a backlight unit 4200 and a convexly curved frame 4300. The LCD panel 4100 is convexly curved to have a uniform curvature when viewed from an X-Y plan. In the present exemplary embodiment, a curvature radius corresponding to the curvature is about 1,000 mm to about 9,000 mm. Alternatively, various curvature radiuses may be adapted thereto.

[0125] The curved LCD panel 4100 may have a curved shape of uniform curvature when viewed from an X-Y plan sense. In the present exemplary embodiment, the curved LCD panel 4100 may include a lower substrate 4120, an upper substrate 4140 facing the lower substrate 4120, and a liquid crystal layer interposed between the lower substrate 4120 and the upper substrate 4140. A size of the upper substrate 4140 is substantially smaller than that of the lower substrate 4120. Thus, an area which is not covered by the upper substrate

4140 is exposed. A pad part 4122 is formed on an exposed area of the lower substrate 4120.

[0126] The curved LCD panel 4100 may be curved before the curved LCD panel 4100 is inserted into the convexly curved frame 4300. Alternatively, the curved LCD panel 4100 may be curved after the curved LCD panel 4100 is inserted into the convexly curved frame 4300. For one example, when the curved LCD panel 4100 is a flexible type, the curved LCD panel 4100 may be curved after the curved LCD panel 4100 is inserted into the already convexly curved frame 4300. For another example, when the curved LCD panel 4100 has a ridge type, the curved LCD panel 4100 may be manufactured to have a curved shape of a predetermined curvature before the curved LCD panel 4100 is inserted into the convexly curved frame 4300.

[0127] The curved LCD panel 4100 may have a curved shape by various manufacturing methods. For example, a flat LCD panel is disposed between a first curved mold of a convex shape and a second curved mold of a concave shape facing the first curved mold, and then the curved LCD panel 4100 may be manufactured through a heat treatment and/or a pressing treatment. In this case, a bottom surface of an upper substrate of the flat LCD panel is disposed to contact with the first curved mold.

[0128] The lower substrate 4120 is a substrate on which TFTs that are switching elements are formed in a matrix organization. In the present exemplary embodiment, the lower substrate 4120 has a curved shape of uniform curvature. The TFT has a source terminal connected to a data line, a gate terminal connected to a gate line, and a drain terminal connected to a pixel electrode of a transparent conductive material. A data pad part 4122 extended from the data line is disposed on an image non-displaying area of the lower substrate 4120. Alternatively, a gate pad part extended from the gate line may be further disposed in a non-display area of the lower substrate 4120.

[0129] The upper substrate 4140 is disposed to face the lower substrate 4120. The upper substrate 4140 includes a red pixel, a green pixel and a blue pixel that are formed to realize colors. In the present exemplary embodiment, the upper substrate 4140 has a curved shape of uniform curvature. A common electrode is formed on the upper substrate 4140, which is opposite to the pixel electrode of the lower substrate 4120. The common electrode includes an optically transparent and electrically conductive material.

[0130] Alternatively, the curved LCD panel 4100 may include an upper substrate on which color filters are formed and an opposition substrate on which a common electrode is formed to face the upper substrate.

[0131] When power is applied to a gate terminal of the TFT and the TFT is turned on, an electric field is generated between the pixel electrode and the common electrode. The electric field varies an aligning angle of the liquid crystal molecules interposed between the lower substrate 4120 and the upper substrate 4140. Thus, a light transmittance of the liquid crystal layer is varied in accordance with the variation of the aligning angle of the liquid crystal, so a desired image may be obtained.

[0132] The curved LCD panel 4100 may include a first polarization film (not shown) disposed below the lower substrate 4120 and a second polarization film (not shown) disposed on the upper substrate 4140. The first polarization film includes a light transmitting axis of a first direction to polarize lights in a first direction. The second polarization film

includes a light transmitting axis of a different second direction to polarize lights in a second direction. For example, the light transmitting axis of the first polarization film may be perpendicular to the light transmitting axis of the second polarization film.

[0133] The backlight unit **4200** is disposed at a rear surface of the curved LCD panel **4100** to provide lights to the curved LCD panel **4100**. In the present exemplary embodiment, the backlight unit **4200** has a curved shape which is curved in accordance with a curvature of the curved LCD panel **4100**. In the present exemplary embodiment, a curvature radius of the backlight unit **4200** may be about 1,000 mm to 4,000 mm. In the present exemplary embodiment, when the curved LCD panel **4100** has a curvature radius of one of about 1,000 mm to about 9,000 mm, the backlight unit **4200** may have a curvature radius substantially smaller than a curvature radius of the curved LCD panel **4100**. For example, when the curved LCD panel **4100** has a curvature radius of about 7,000 mm, the backlight unit **4200** may have a curvature radius substantially greater than about 1,000 mm and substantially smaller than about 7,000 mm.

[0134] The backlight unit **4200** includes a light source assembly **4210** with multi-colored light sources configured for emitting lights of different colors and an optical assembly **4220** enhancing light characteristics emitted from the light sources assembly **4210**. In the present exemplary embodiment, a curvature radius of the optical assembly **4220** may be substantially smaller than a curvature radius of the curved LCD panel **4100**, and may be substantially greater than a curvature radius of the light source assembly **4210**.

[0135] The light source assembly **4210** includes a plurality of LED packages **4212** emitting lights and a printed circuit board **4214** on which the LED packages **4212** are mounted. A signal wiring (not shown) for providing the LED packages **4212** with driving voltages, is formed on the printed circuit board **4214**. The light source assembly **4210** may be disposed in correspondence with a direction parallel with a long side of the curved LCD panel **4100**. Alternatively, the light source assembly **4210** may be disposed in correspondence with a direction parallel with a short side of the curved LCD panel **4100**.

[0136] Moreover, in order to prevent a blue transmittance ratio from being decreased by a buckling phenomenon generated in the curved LCD panel **4100**, the design may include a variation in the disposing of or the structures of the LED packages **4212** across the area of the display. For example, when viewed from an X-Y plan of the curved LCD panel **4100**, a light amount of blue, which are emitted from the LED packages **4212** disposed on a middle area between a central portion parallel with Y-axis and an edge portion parallel with Y-axis, may be increased. For one example, it may increase the number of blue LEDs rather than the number of red LEDs or the number of green LEDs, thereby increasing a light amount of the blue part of the spectrum in areas where there are more blue LED's. For another example, it may increase a voltage provided to the blue LED's rather than a voltage provided to the red LED's of the same area portion or a voltage provided to the green LED's of that area portion, thereby increasing a relatively light amount in the blue part of the spectrum.

[0137] The light source assembly **4210** may further include a bottom plate **4216** and a reflection sheet **4218**.

[0138] The bottom plate **4216** has a curved shape of a uniform curvature to secure printed circuit boards **4214** hav-

ing LED packages **4212** mounted thereon. In the present exemplary embodiment, the bottom plate **4216** may have a curved shape by various manufacturing methods. For example, a flat bottom plate is disposed between a first curved mold of a concave shape and a second curved mold of a convex shape facing the first curved mold, and then the bottom plate **4216** may be manufactured through a heat treatment and/or a pressing treatment. In this case, a bottom surface of the flat bottom plate is disposed to contact with the second curved mold.

[0139] The reflection sheet **4218** is disposed on the bottom plate **4216** and is disposed below the light source assembly **4210** to reflect lights incident from the light source assembly **4210** toward the diffusion plate **4226**.

[0140] The optical assembly **4220** may include a diffusion plate **4226** and optical sheets **4228**.

[0141] The diffusion plate **4226** has a curved shape of uniform curvature. The diffusion plate **4226** diffuses lights emitted from the light source assembly **4210** or lights reflected by the reflection sheet **4218** to provide the optical sheets **4228** with the diffused lights. In the present exemplary embodiment, the diffusion plate **4226** may have a curved shape by various manufacturing methods. For example, a flat diffusion plate is disposed between a first curved mold of a concave shape and a second curved mold of a convex shape facing the first curved mold, and then the diffusion plate **4226** may be manufactured through a heat treatment and/or a pressing treatment. In this case, a bottom surface of the flat bottom plate is disposed to contact with the second curved mold.

[0142] The optical sheets **4228** are disposed on the diffusion plate **4226** to increase efficiency of lights incident from the diffusion plate **4226**. The optical sheets **4228** may include a diffusion sheet again diffusing lights diffused by the diffusion plate **4226** and a prism sheet condensing the lights diffused by the diffusion sheet. For one example, the prism sheet may include a vertical prism sheet condensing lights in a vertical direction and a horizontal prism sheet condensing lights in a horizontal direction.

[0143] The convexly curved frame **4300** includes an upper frame part **4310**, a lower frame part **4320**, a left frame part **4330** and a right frame part **4340** to secure the curved LCD panel **4100** and the backlight unit **4200**. The convexly curved frame **4300** has a curved shape of uniform curvature.

[0144] As described above, according to the present disclosure of invention, a planarized area (meaning a non-stepped area) that include a non-stepped preliminary contact area corresponding to where an upper contact surface of a column spacer is designed to make contact is provided so as to prevent a cell gap from being varied due to a misalignment between a first substrate and a second substrate even through an LCD panel is curved. Thus, it may remove display defects due to a cell gap variation, thereby enhancing display characteristics.

[0145] Having described exemplary embodiments of the present disclosure of invention, it is further noted that it will be readily apparent to those of reasonable skill in the art in light of the foregoing that various modifications may be made without departing from the spirit and scope of the present teachings.

What is claimed is:

1. A curved liquid crystal display panel comprising:
  - a first substrate comprising a column spacer, the column spacer having a base portion anchored to the first substrate and an opposed contact making end;
  - a liquid crystal layer; and

a second substrate spaced apart from the first substrate and comprising a preliminary contact area corresponding to a preliminary disposition of the contact making end of the column spacer, the preliminary contact area being part of a larger non-stepped area (planarized area), the second substrate being combined with the first substrate to receive the liquid crystal layer in the spacing therebetween.

2. The curved liquid crystal display panel of claim 1, wherein the non-stepped area is formed along a curvature direction of the curved liquid crystal display panel.

3. The curved liquid crystal display panel of claim 1, wherein a length of the non-stepped area is in proportion to a size of the curved liquid crystal display panel and is in inverse proportion to a curvature radius of the curved liquid crystal display panel.

4. The curved liquid crystal display panel of claim 1, wherein a length of the non-stepped area satisfies the following equation:

$$D \geq \frac{L \times T}{R} \times 0.1,$$

wherein, 'D' denotes a length of the non-stepped area, 'L' denotes a length of a panel in parallel with a curvature direction, 'T' denotes a thickness of a base substrate of the first substrate or a thickness of a base substrate of the second substrate, and 'R' denotes a curvature radius.

5. The curved liquid crystal display panel of claim 1, wherein the first substrate comprises a lower substrate on which a plurality of switching elements is formed, and wherein the column spacer is fixedly anchored on and protrudes from the first substrate.

6. The curved liquid crystal display panel of claim 5, wherein the second substrate comprises a light-blocking layer formed in a stripes only configuration parallel with each other, and

wherein the stripes of the light-blocking layer are in parallel with gate lines connected to the switching element.

7. The curved liquid crystal display panel of claim 1, wherein the first substrate comprises a lower substrate on which a plurality of switching elements and a color filter layer covering the switching element are formed, and

wherein the column spacer is formed on the color filter layer.

8. The curved liquid crystal display panel of claim 1, wherein the second substrate comprises a lower substrate on which a plurality of switching elements is formed.

9. The curved liquid crystal display panel of claim 8, wherein the first substrate comprises a light-blocking layer formed in a stripes only configuration in parallel with each other, and

wherein the light-blocking layer is in parallel with gate lines connected to the switching element.

10. The curved liquid crystal display panel of claim 1, wherein the second substrate comprises a lower substrate on which a plurality of switching elements and a color filter layer covering the switching element are formed.

11. The curved liquid crystal display panel of claim 10, wherein the color filter layer comprises a first color filter layer and a different second color filter layer, and

wherein an overlapped portion of the first color filter layer and the second color filter layer is planarized to define the non-stepped area.

12. The curved liquid crystal display panel of claim 1, wherein the curved liquid crystal display panel has a concave shape.

13. The curved liquid crystal display panel of claim 1, wherein the curved liquid crystal display panel has a convex shape.

\* \* \* \* \*

专利名称(译)	弯曲的液晶显示板		
公开(公告)号	<a href="#">US20150116621A1</a>	公开(公告)日	2015-04-30
申请号	US14/249164	申请日	2014-04-09
[标]申请(专利权)人(译)	三星显示有限公司		
申请(专利权)人(译)	三星DISPLAY CO., LTD.		
当前申请(专利权)人(译)	三星DISPLAY CO., LTD.		
[标]发明人	PARK MIN WOOK PARK JOO HWAN SON JEONG MAN		
发明人	PARK, MIN-WOOK PARK, JOO-HWAN SON, JEONG-MAN		
IPC分类号	G02F1/1339 G02F1/1335 G02F1/1362		
CPC分类号	G02F1/13394 G02F1/136209 G02F2001/133519 G02F2001/136222 G02F1/133514 G02F1/133305		
优先权	1020130130225 2013-10-30 KR		
其他公开文献	US9588379		
外部链接	<a href="#">Espacenet</a> <a href="#">USPTO</a>		

摘要(译)

弯曲液晶显示面板包括第一基板，液晶层和第二基板。第一基板包括固定地锚固到其并从其突出的柱状间隔物。第二基板包括对应于柱状间隔物的接触自由端的无级初步接触区域，其中初步接触区域是较大且非阶梯状区域的一部分。第二基板与第一基板结合以在其间接收液晶层。非阶梯区域的尺寸被设计成考虑到由于第一和第二基板的曲率而使柱状间隔物的接触自由端接触的位置的移动。

