



(19) **United States**

(12) **Patent Application Publication**
Li et al.

(10) **Pub. No.: US 2013/0249966 A1**
(43) **Pub. Date: Sep. 26, 2013**

(54) **LIQUID CRYSTAL DISPLAY HAVING COMMON-VOLTAGE COMPENSATION MECHANISM AND COMMON-VOLTAGE COMPENSATION METHOD**

Publication Classification

(51) **Int. Cl.**
G09G 3/36 (2006.01)
(52) **U.S. Cl.**
CPC *G09G 3/36* (2013.01); *G09G 3/3607* (2013.01)
USPC **345/690**; 345/212; 345/94

(71) Applicant: **AU Optronics Corp.**, Hsin-Chu (TW)

(72) Inventors: **Ching-Lin Li**, Hsin-Chu (TW); **Yi-Fan Lin**, Hsin-Chu (TW); **Jen-Chieh Chen**, Hsin-Chu (TW)

(73) Assignee: **AU Optronics Corp.**, Hsin-Chu (TW)

(21) Appl. No.: **13/902,852**

(22) Filed: **May 26, 2013**

Related U.S. Application Data

(62) Division of application No. 13/300,667, filed on Nov. 21, 2011.

Foreign Application Priority Data

May 17, 2011 (TW) 100117195

(57) **ABSTRACT**

A liquid crystal display having common voltage compensation mechanism includes a liquid-crystal capacitor common voltage, a storage capacitor common electrode for receiving a liquid-crystal capacitor common voltage, a common voltage generator for providing the liquid-crystal capacitor common voltage according to a preliminary common voltage, a common voltage compensation circuit electrically connected to the liquid-crystal capacitor common electrode and the storage capacitor common electrode, and a timing controller electrically connected to the common voltage compensation circuit. The common voltage compensation circuit is utilized for generating the storage capacitor common voltage through performing a ripple inverting operation according to the liquid-crystal capacitor common voltage, the preliminary common voltage and a compensation control signal. The timing controller is employed to analyze an image input signal for generating the compensation control signal.

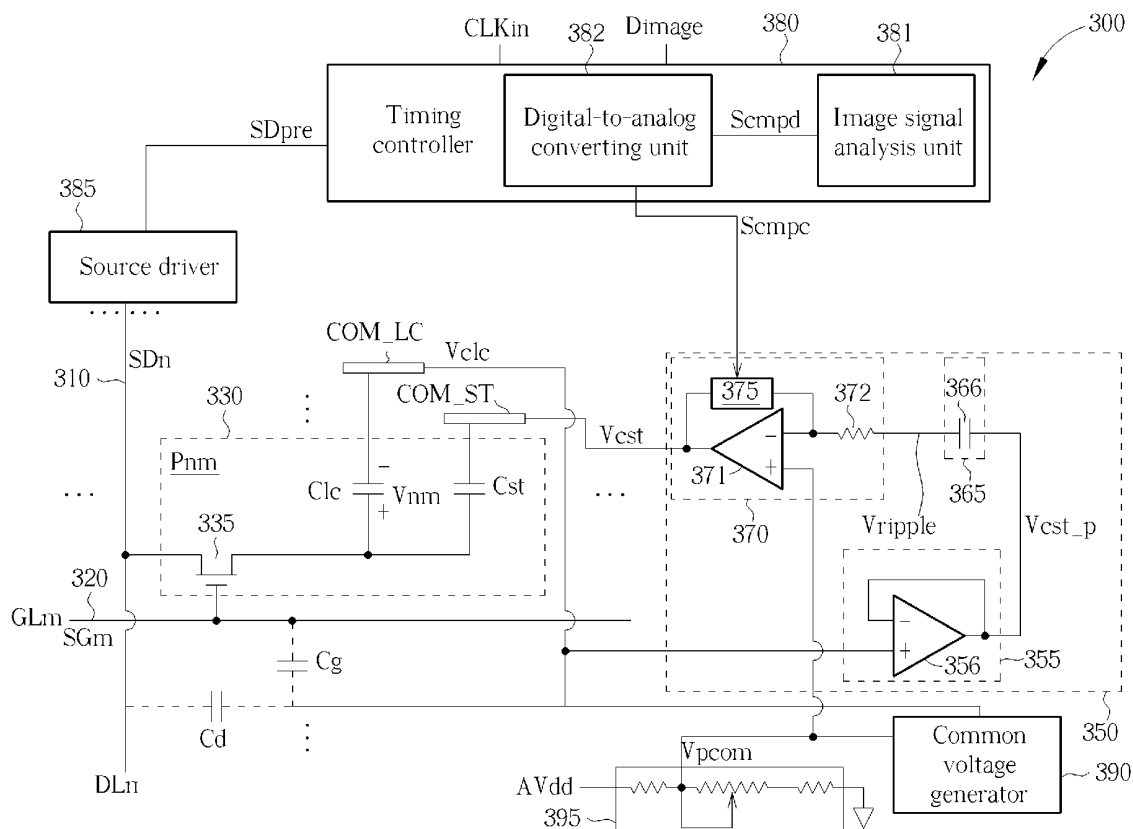

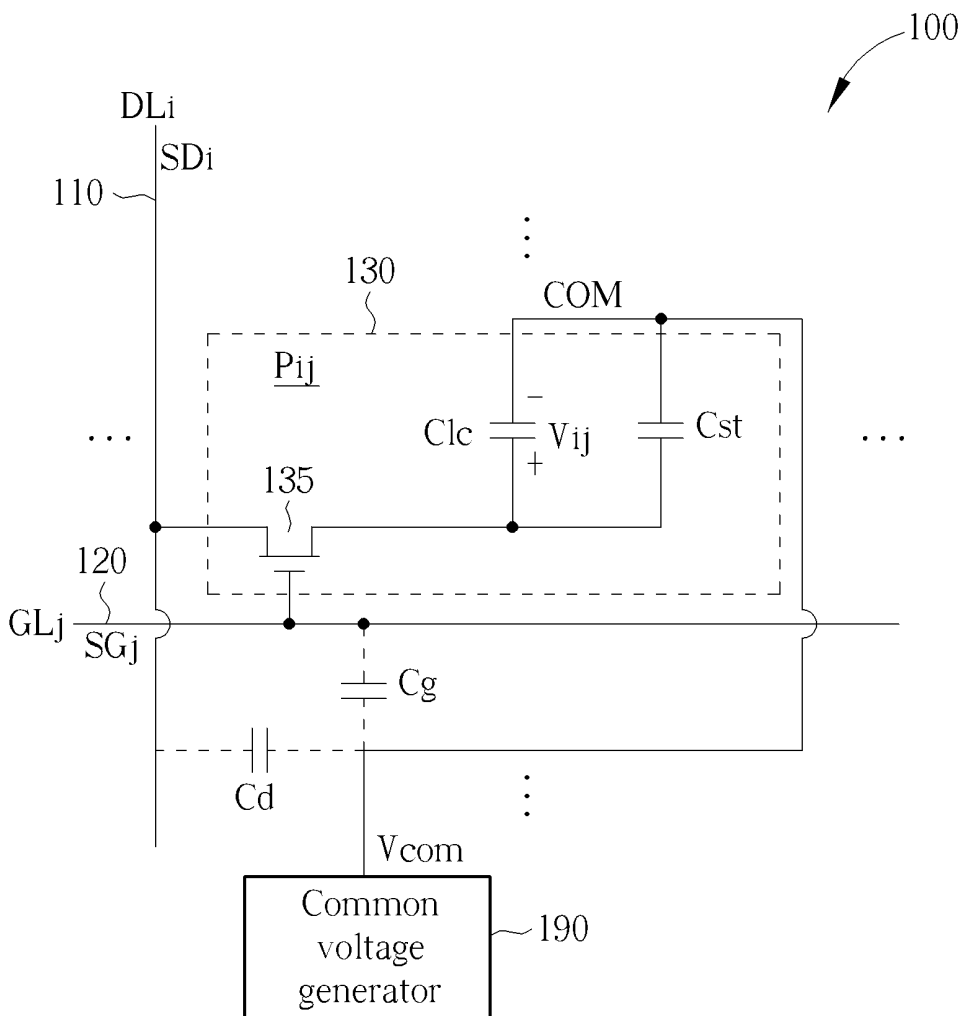

FIG. 1 PRIOR ART

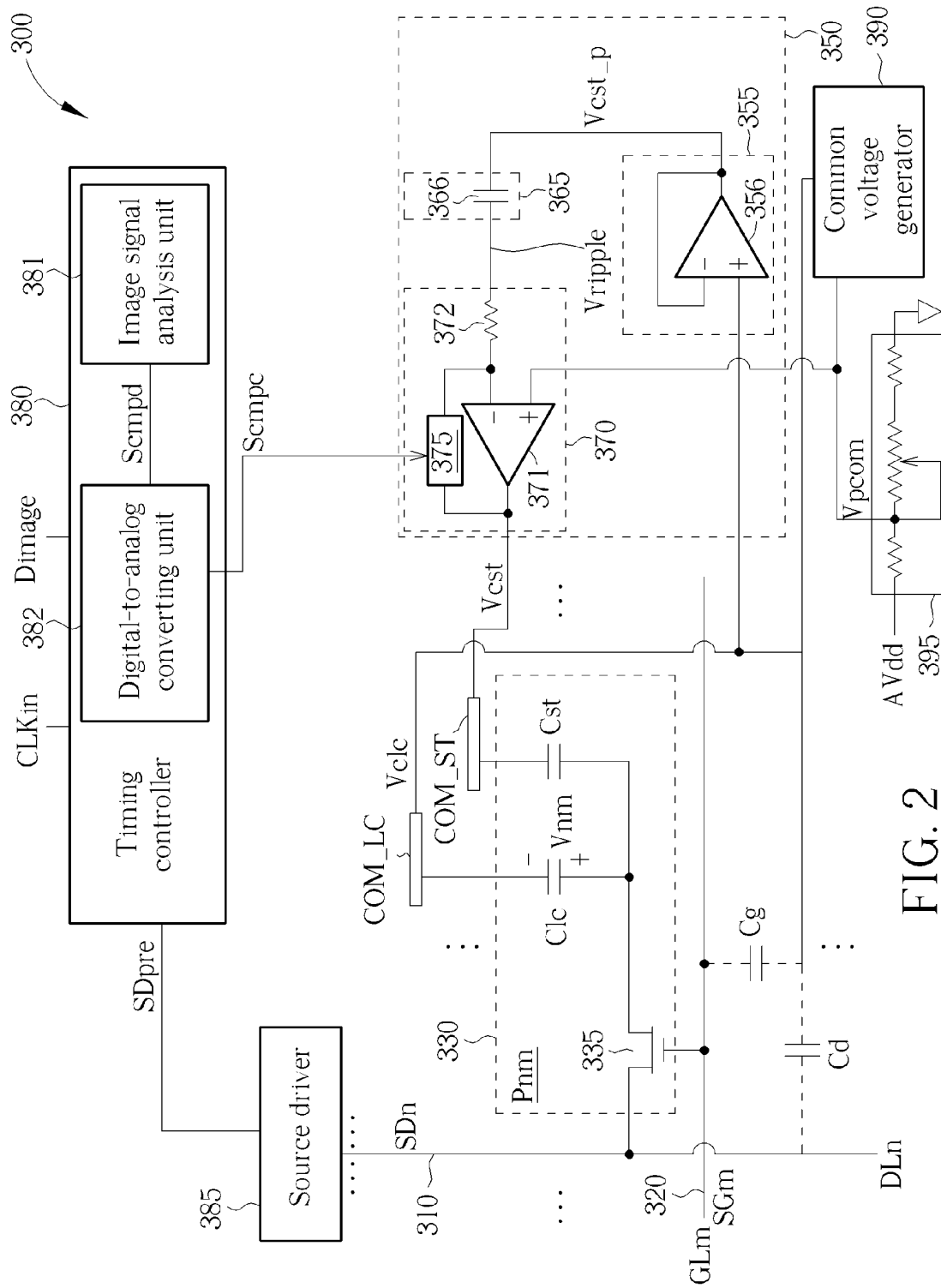

FIG. 2

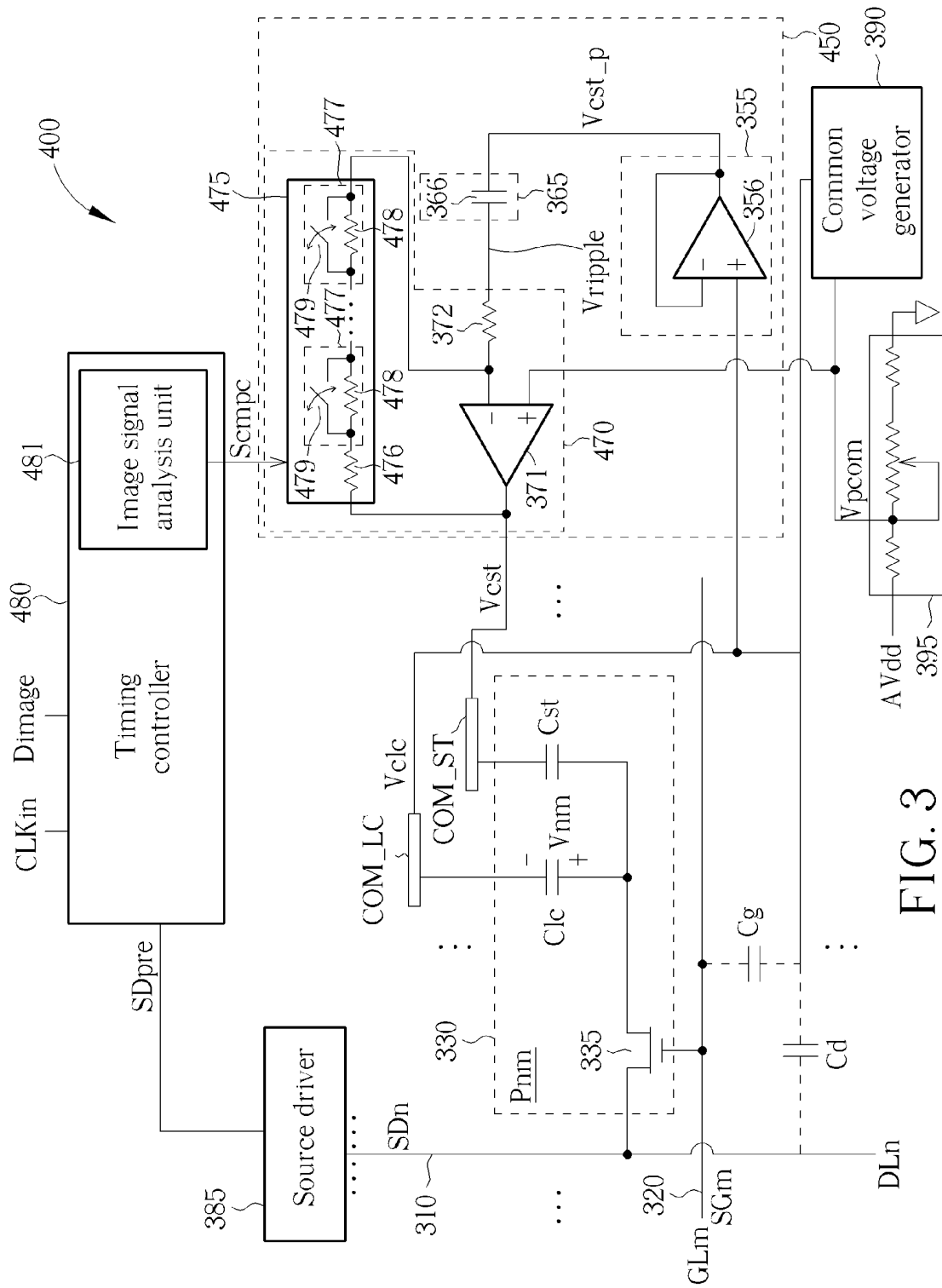

FIG. 3

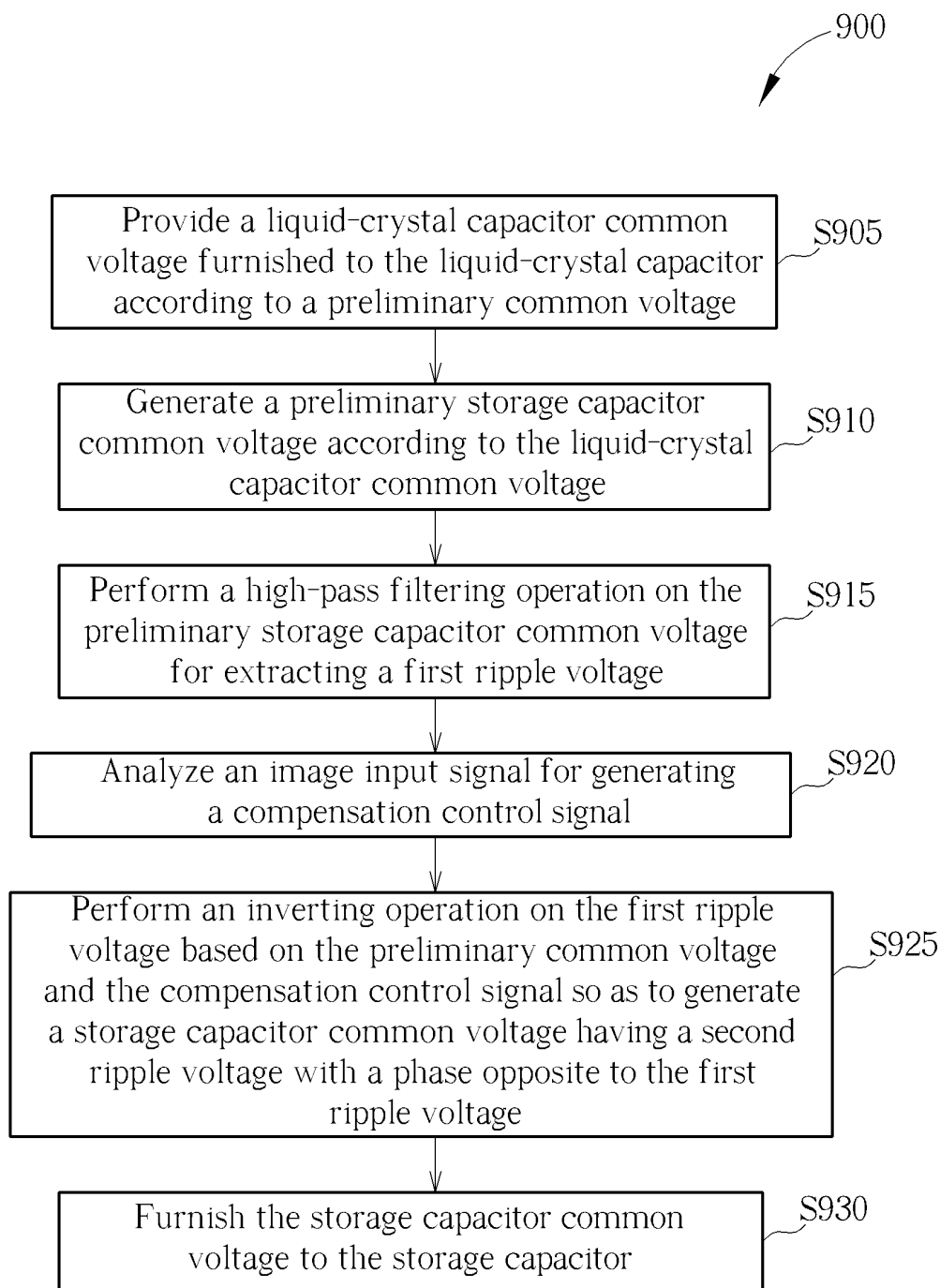

FIG. 4

**LIQUID CRYSTAL DISPLAY HAVING
COMMON-VOLTAGE COMPENSATION
MECHANISM AND COMMON-VOLTAGE
COMPENSATION METHOD**

CROSS REFERENCE TO RELATED
APPLICATIONS

[0001] This application is a divisional application of U.S. application Ser. No. 13/300,667 filed Nov. 21, 2011, the entirety of which is hereby incorporated by reference.

BACKGROUND OF THE INVENTION

[0002] 1. Field of the Invention

[0003] The disclosure relates to a liquid crystal display, and more particularly, to a liquid crystal display having common-voltage compensation mechanism and related common-voltage compensation method.

[0004] 2. Description of the Prior Art

[0005] Liquid crystal displays (LCDs) have advantages of a thin profile, low power consumption, and low radiation, and are broadly adopted for panel displaying in a variety of electronic products. The operation of a liquid crystal display is featured by modulating the voltage drop across opposite sides of a liquid crystal layer for twisting the angles of liquid crystal molecules in the liquid crystal layer so that the transmittance of the liquid crystal layer can be controlled for illustrating images with the aid of light source provided by a backlight module. It is well known that the polarity of the voltage drop across opposite sides of the liquid crystal layer should be inverted periodically for protecting the liquid crystal layer from causing permanent deterioration due to polarization, and also for avoiding an occurrence of image sticking phenomenon on the LCD screen. Accordingly, various inversion operations, such as frame-inversion driving operations, line-inversion driving operations, pixel-inversion driving operations and dot-inversion driving operations, are developed to drive the liquid crystal display for improving image display performance.

[0006] FIG. 1 is a circuit diagram schematically showing a prior-art liquid crystal display **100**. As shown in FIG. 1, the liquid crystal display **100** comprises a plurality of data lines **110**, a plurality of gate lines **120**, a plurality of pixel units **130** and a common voltage generator **190**. The data lines **110** include a data line DLi for transmitting a data signal SDi, the gate lines **120** include a gate line GLj for transmitting a gate signal SGj, and the pixel units **130** include a pixel unit Pij having a data switch **135**, a liquid-crystal capacitor Clc and a storage capacitor Cst. The data switch **135** is utilized for providing a control of writing the data signal SDi according to the gate signal SGj, thereby generating a desired pixel voltage Vij. The common voltage generator **190** is employed to provide a common voltage Vcom furnished to a common electrode COM. Since parasitic capacitor Cd exists between the data line DLi and the common electrode COM, and since parasitic capacitor Cg exists between the gate line GLj and the common electrode COM, both the voltage changes of the data signal SDi and the gate signal SGj have an effect on the common voltage Vcom at the common electrode COM, which is known as the phenomenon of crosstalk interference occurring to the operation of the liquid crystal display **100**. In particular, if adjacent pixel data of a frame to be displayed include lots of black/white gray-level switching pixel data, the aforementioned inversion driving operation of the liquid

crystal display **100** is likely to cause serious crosstalk interference, which leads to an occurrence of significant pixel brightness distortion and degrades the display quality on the LCD screen.

SUMMARY OF THE INVENTION

[0007] In accordance with an embodiment, a liquid crystal display having common-voltage compensation mechanism is provided. The liquid crystal display comprises a data line for transmitting a data signal, a gate line for transmitting a gate signal, a data switch electrically connected to the data line and the gate line, a liquid-crystal capacitor, a storage capacitor, a common voltage generator electrically connected to the liquid-crystal capacitor, a common-voltage compensation circuit electrically connected to the common voltage generator and the storage capacitor, and a timing controller electrically connected to the common-voltage compensation circuit.

[0008] The data switch is utilized for providing a control of writing the data signal according to the gate signal. The liquid-crystal capacitor has a first end electrically connected to the data switch and a second end for receiving a liquid-crystal capacitor common voltage. The storage capacitor has a first end electrically connected to the data switch and a second end for receiving a storage capacitor common voltage. The common voltage generator is employed to provide the liquid-crystal capacitor common voltage according to a preliminary common voltage. The common-voltage compensation circuit is put in use for generating the storage capacitor common voltage through performing a ripple inverting operation according to the liquid-crystal capacitor common voltage, the preliminary common voltage and a compensation control signal. The timing controller is utilized for analyzing an image input signal for generating the compensation control signal.

[0009] The present invention further provides a common-voltage compensation method for use in a liquid crystal display having a liquid-crystal capacitor and a storage capacitor. The common-voltage compensation method comprises providing a liquid-crystal capacitor common voltage furnished to the liquid-crystal capacitor according to a preliminary common voltage, generating a preliminary storage capacitor common voltage according to the liquid-crystal capacitor common voltage, performing a high-pass filtering operation on the preliminary storage capacitor common voltage for extracting a first ripple voltage, analyzing an image input signal for generating a compensation control signal, performing an inverting operation on the first ripple voltage based on the preliminary common voltage and the compensation control signal so as to generate a storage capacitor common voltage having a second ripple voltage with a phase opposite to the first ripple voltage, and furnishing the storage capacitor common voltage to the storage capacitor.

[0010] These and other objectives of the present invention will no doubt become obvious to those of ordinary skill in the art after reading the following detailed description of the preferred embodiment that is illustrated in the various figures and drawings.

BRIEF DESCRIPTION OF THE DRAWINGS

[0011] FIG. 1 is a circuit diagram schematically showing a prior-art liquid crystal display.

[0012] FIG. 2 is a circuit diagram schematically showing a liquid crystal display in accordance with a first embodiment.

[0013] FIG. 3 is a circuit diagram schematically showing a liquid crystal display in accordance with a second embodiment.

[0014] FIG. 4 is a flowchart depicting a common-voltage compensation method for use in a liquid crystal display having a liquid-crystal capacitor and a storage capacitor.

DETAILED DESCRIPTION

[0015] Hereinafter, preferred embodiments of the present invention will be described in detail with reference to the accompanying drawings. Here, it is to be noted that the present invention is not limited thereto. Furthermore, the step serial numbers regarding the common-voltage compensation method are not meant thereto limit the operating sequence, and any rearrangement of the operating sequence for achieving same functionality is still within the spirit and scope of the invention.

[0016] FIG. 2 is a circuit diagram schematically showing a liquid crystal display 300 in accordance with a first embodiment. As shown in FIG. 2, the liquid crystal display 300 comprises a plurality of data lines 310, a plurality of gate lines 320, a plurality of pixel units 330, a common-voltage compensation circuit 350, a timing controller 380, a source driver 385, a common voltage generator 390, and a voltage dividing unit 395. The data lines 310 include a data line DL_n for transmitting a data signal SD_n , the gate lines 320 include a gate line GL_m for transmitting a gate signal SG_m , and the pixel units 330 include a pixel unit P_{nm} having a data switch 335, a liquid-crystal capacitor Clc and a storage capacitor Cst . The data switch 335 may be a thin film transistor (TFT), a field effect transistor (FET) or other similar device having connection/disconnection switching functionality. The data switch 335 is utilized for providing a control of writing the data signal SD_n according to the gate signal SG_m , thereby generating a desired pixel voltage V_{nm} . The liquid-crystal capacitor Clc is electrically connected between the data switch 335 and a liquid-crystal capacitor common electrode COM_{LC} . The storage capacitor Cst is electrically connected between the data switch 335 and a storage capacitor common electrode COM_{ST} .

[0017] The timing controller 380 is utilized for generating a preliminary data signal SD_{pre} according to an image input signal $Dimage$ and a clock signal CLK_{in} , such that the source driver 385 is able to provide the data signal SD_n furnished to the data line DL_n according to the preliminary data signal SD_{pre} . Besides, the timing controller 380 is further employed to analyze the image input signal $Dimage$ for generating a compensation control signal $Scmpc$ furnished to the common-voltage compensation circuit 350. The voltage dividing unit 395 is put in use for performing a voltage dividing operation on a power voltage AV_{dd} so as to generate a preliminary common voltage V_{pcom} . The common voltage generator 390, electrically connected to the voltage dividing unit 395, is utilized for providing a liquid-crystal capacitor common voltage V_{cic} furnished to the liquid-crystal capacitor common electrode COM_{LC} and the common-voltage compensation circuit 350 according to the preliminary common voltage V_{pcom} .

[0018] The common-voltage compensation circuit 350 is utilized for generating a storage capacitor common voltage V_{cst} furnished to the storage capacitor common electrode COM_{ST} through performing a ripple inverting operation according to the liquid-crystal capacitor common voltage V_{cic} , the preliminary common voltage V_{pcom} and the com-

penensation control signal $Scmpc$. The common-voltage compensation circuit 350 comprises a buffer 355, a high-pass filter 365, and a ripple-voltage inverter 370. The buffer 355 is utilized for outputting a preliminary storage capacitor common voltage V_{cst_p} according to the liquid-crystal capacitor common voltage V_{cic} . The high-pass filter 365, electrically connected between the buffer 355 and the ripple-voltage inverter 370, is employed to perform a high-pass filtering operation on the preliminary storage capacitor common voltage V_{cst_p} for extracting a first ripple voltage V_{ripple} furnished to the ripple-voltage inverter 370. It is noted that the preliminary storage capacitor common voltage V_{cst_p} is substantially identical to the liquid-crystal capacitor common voltage V_{cic} , and therefore the ripple voltage of the liquid-crystal capacitor common voltage V_{cic} is substantially identical to the first ripple voltage V_{ripple} . The ripple-voltage inverter 370, electrically connected to the voltage dividing unit 395, the high-pass filter 365, the timing controller 380 and the storage capacitor Cst , is put in use for performing an inverting operation on the first ripple voltage V_{ripple} based on the preliminary common voltage V_{pcom} and the compensation control signal $Scmpc$ so as to generate the storage capacitor common voltage V_{cst} having a second ripple voltage with a phase opposite to the first ripple voltage V_{ripple} . It is noted that the peak-to-peak value ratio of the second ripple voltage to the first ripple voltage V_{ripple} is set by the ripple-voltage inverter 370 based on the compensation control signal $Scmpc$.

[0019] In the embodiment shown in FIG. 2, the buffer 355 comprises a first operational amplifier 356, the high-pass filter 365 comprises a capacitor 366, the ripple-voltage inverter 370 comprises a second operational amplifier 371, a first resistor 372 and a voltage-controlled resistor unit 375. The first operational amplifier 356 has a non-inverting input end electrically connected to the liquid-crystal capacitor common electrode COM_{LC} for receiving the liquid-crystal capacitor common voltage V_{cic} , an output end for outputting the preliminary storage capacitor common voltage V_{cst_p} , and an inverting input end electrically connected to the output end. The capacitor 366 is electrically connected between the first resistor 372 and the output end of the first operational amplifier 356. The second operational amplifier 371 includes a non-inverting input end electrically connected to the voltage dividing unit 395 for receiving the preliminary common voltage V_{pcom} , an output end for outputting the storage capacitor common voltage V_{cst} , and an inverting input end electrically connected to a connection node of the first resistor 372 and the voltage-controlled resistor unit 375.

[0020] The first resistor 372 is electrically connected between the capacitor 366 and the inverting input end of the second operational amplifier 371. The voltage-controlled resistor unit 375 is electrically connected between the inverting input end and the output end of the second operational amplifier 371. The voltage-controlled resistor unit 375 is further electrically connected to the timing controller 380 for receiving the compensation control signal $Scmpc$. The voltage-controlled resistor unit 375 is utilized for controlling resistance between the inverting input end and the output end of the second operational amplifier 371 according to the compensation control signal $Scmpc$, which in turn controls the peak-to-peak value ratio of the aforementioned second ripple voltage to the first ripple voltage V_{ripple} . That is, the common-voltage compensation circuit 350 controls the peak-to-

peak value ratio of the aforementioned second ripple voltage to the first ripple voltage V_{ripple} based on an analog control mechanism.

[0021] The timing controller **380** includes an image signal analysis unit **381** and a digital-to-analog converting unit **382**. The image signal analysis unit **381** is utilized for analyzing the image input signal D_{image} corresponding to a frame to be displayed so as to generate a digital compensation signal $Scmpd$. The digital-to-analog converting unit **382**, electrically connected to the image signal analysis unit **381**, is employed to perform a digital-to-analog converting operation on the digital compensation signal $Scmpd$ for generating the compensation control signal $Scmpc$. In one embodiment, the image signal analysis unit **381** generates a gray-level variation statistical value through analyzing adjacent pixel data of the frame to be displayed, and provides the digital compensation signal $Scmpd$ according to the gray-level variation statistical value. For instance, the image signal analysis unit **381** may be utilized for setting the digital compensation signal $Scmpd$ to be a default value when the gray-level variation statistical value is less than a first predetermined threshold, and for adjusting the digital compensation signal $Scmpd$ in response to the gray-level variation statistical value when the gray-level variation statistical value is not less than the first predetermined threshold. In another embodiment, the image signal analysis unit **381** generates a black/white gray-level switching statistical value through analyzing adjacent pixel data of the frame to be displayed, and provides the digital compensation signal $Scmpd$ according to the black/white gray-level switching statistical value. For instance, the image signal analysis unit **381** may be utilized for setting the digital compensation signal $Scmpd$ to be a default value when the black/white gray-level switching statistical value is less than a second predetermined threshold, and for adjusting the digital compensation signal $Scmpd$ in response to the black/white gray-level switching statistical value when the black/white gray-level switching statistical value is not less than the second predetermined threshold.

[0022] In view of that, although the voltage variations of the data signal SD_n and the gate signal SG_m have an effect on the first ripple voltage V_{ripple} of the liquid-crystal capacitor common voltage V_{cic} via the parasitic capacitors C_d and C_g , the voltage variation of the liquid-crystal capacitor common voltage V_{cic} which is caused by crosstalk interference can be compensated by the second ripple voltage of the storage capacitor common voltage V_{cst} in that the phase of the second ripple voltage is opposite to that of the first ripple voltage V_{ripple} , thereby suppressing the effect of crosstalk interference to improve image display quality. Besides, since the ripple-voltage inverter **370** performs the ripple inverting operation in response to the compensation control signal $Scmpc$ which is generated based on an analysis of the image input signal D_{image} , i.e. the aforementioned compensation operation is performed according to the gray-level variation statistical feature of the frame to be displayed, the image display quality of the liquid crystal display **300** is then further improved through effectively suppressing the crosstalk interference caused by the inversion driving operation thereof.

[0023] FIG. 3 is a circuit diagram schematically showing a liquid crystal display **400** in accordance with a second embodiment. As shown in FIG. 3, the liquid crystal display **400** is similar to the liquid crystal display **300** shown in FIG. 2, differing in that the common-voltage compensation circuit **350** is replaced with a common-voltage compensation circuit

450, and the timing controller **380** is replaced with a timing controller **480**. The timing controller **480** is utilized for generating a preliminary data signal SD_{pre} furnished to the source driver **385** according to an image input signal D_{image} and a clock signal CLK_{in} . Besides, the timing controller **480** is further employed to analyze the image input signal D_{image} for generating a compensation control signal $Scmpc$ with at least one bit which is furnished to the common-voltage compensation circuit **450**. That is, the compensation control signal $Scmpc$ shown in FIG. 3 is a digital signal. The common-voltage compensation circuit **450** is utilized for generating a storage capacitor common voltage V_{cst} furnished to the storage capacitor common electrode COM_{ST} through performing a ripple inverting operation according to the liquid-crystal capacitor common voltage V_{cic} , the preliminary common voltage V_{pcom} and the compensation control signal $Scmpc$.

[0024] The timing controller **480** includes an image signal analysis unit **481** which is utilized for analyzing the image input signal D_{image} corresponding to a frame to be displayed so as to generate the compensation control signal $Scmpc$ in digital form. In one embodiment, the image signal analysis unit **481** generates a gray-level variation statistical value through analyzing adjacent pixel data of the frame to be displayed, and provides the compensation control signal $Scmpc$ according to the gray-level variation statistical value. For instance, the image signal analysis unit **481** may be utilized for setting the compensation control signal $Scmpc$ to be a default value when the gray-level variation statistical value is less than a first predetermined threshold, and for adjusting the compensation control signal $Scmpc$ in response to the gray-level variation statistical value when the gray-level variation statistical value is not less than the first predetermined threshold. In another embodiment, the image signal analysis unit **481** generates a black/white gray-level switching statistical value through analyzing adjacent pixel data of the frame to be displayed, and provides the compensation control signal $Scmpc$ according to the black/white gray-level switching statistical value. For instance, the image signal analysis unit **481** may be utilized for setting the compensation control signal $Scmpc$ to be a default value when the black/white gray-level switching statistical value is less than a second predetermined threshold, and for adjusting the compensation control signal $Scmpc$ in response to the black/white gray-level switching statistical value when the black/white gray-level switching statistical value is not less than the second predetermined threshold.

[0025] The common-voltage compensation circuit **450** is similar to the common-voltage compensation circuit **350** shown in FIG. 2, differing in that the ripple-voltage inverter **370** is replaced with a ripple-voltage inverter **470**. The ripple-voltage inverter **470** comprises the second operational amplifier **371**, the first resistor **372** and a resistor switching module **475**. The resistor switching module **475** is electrically connected between the inverting input end and the output end of the second operational amplifier **371**. The resistor switching module **475** is further electrically connected to the timing controller **480** for receiving the compensation control signal $Scmpc$. The resistor switching module **475** comprises a second resistor **476** and at least one resistor switching unit **477** which are electrically connected in series.

[0026] The resistor switching unit **477** has a third resistor **478** and a switch **479** connected in parallel with the third resistor **478**. The conducting/open state of the switch **479** is controlled by the compensation control signal $Scmpc$,

thereby controlling resistance between the inverting input end and the output end of the second operational amplifier 371, which in turn controls the peak-to-peak value ratio of the aforementioned second ripple voltage to the first ripple voltage V_{ripple} . That is, the common-voltage compensation circuit 450 controls the peak-to-peak value ratio of the aforementioned second ripple voltage to the first ripple voltage V_{ripple} based on a digital control mechanism. Other circuit functionalities of the common-voltage compensation circuit 450 are similar to the common-voltage compensation circuit 350 shown in FIG. 2 and can be inferred by analogy. Accordingly, the liquid crystal display 400 is also able to employ the gray-level variation statistical feature of the frame to be displayed for effectively suppressing various crosstalk interferences occurring to the display driving operation thereof, thereby significantly improving image display quality.

[0027] FIG. 4 is a flowchart depicting a common-voltage compensation method for use in a liquid crystal display having a liquid-crystal capacitor and a storage capacitor. As shown in FIG. 4, the flow 900 of the common-voltage compensation method comprises the following steps:

[0028] Step S905: providing a liquid-crystal capacitor common voltage furnished to the liquid-crystal capacitor according to a preliminary common voltage;

[0029] Step S910: generating a preliminary storage capacitor common voltage according to the liquid-crystal capacitor common voltage;

[0030] Step S915: performing a high-pass filtering operation on the preliminary storage capacitor common voltage for extracting a first ripple voltage;

[0031] Step S920: analyzing an image input signal for generating a compensation control signal;

[0032] Step S925: performing an inverting operation on the first ripple voltage based on the preliminary common voltage and the compensation control signal so as to generate a storage capacitor common voltage having a second ripple voltage with a phase opposite to the first ripple voltage; and

[0033] Step S930: furnishing the storage capacitor common voltage to the storage capacitor.

[0034] Regarding the flow 900 of the common-voltage compensation method described above, the peak-to-peak value ratio of the second ripple voltage to the first ripple voltage is determined according to the compensation control signal. In one embodiment, the step S920 may comprise analyzing the image input signal for generating a digital compensation signal and performing a digital-to-analog converting operation on the digital compensation signal for generating the compensation control signal. In another embodiment, the step S920 may comprise analyzing the image input signal for generating the compensation control signal with at least one bit. Besides, the step S920 may comprise analyzing the image input signal corresponding to a frame to be displayed so as to generate the compensation control signal, e.g. generating a gray-level variation statistical value through analyzing adjacent pixel data of the frame to be displayed and providing the compensation control signal according to the gray-level variation statistical value. The gray-level variation statistical value may be a black/white gray-level switching statistical value. The aforementioned process of providing the compensation control signal according to the gray-level variation statistical value may comprise setting the compensation control signal to be a default value when the gray-level variation statistical value is less than a predetermined threshold, and adjusting the compensation control signal in response to the

gray-level variation statistical value when the gray-level variation statistical value is not less than the predetermined threshold. In view of that, the common-voltage compensation method is able to employ the gray-level variation statistical feature of the frame to be displayed for effectively suppressing various crosstalk interferences occurring to the display driving operation of the liquid crystal display, thereby significantly improving image display quality.

[0035] In conclusion, the common-voltage compensation mechanism of the liquid crystal display according to the present invention is able to effectively suppress various crosstalk interferences occurring to the display driving operation thereof based on the gray-level variation statistical feature of the frame to be displayed, for significantly improving image display quality.

[0036] The present invention is by no means limited to the embodiments as described above by referring to the accompanying drawings, which may be modified and altered in a variety of different ways without departing from the scope of the present invention. Thus, it should be understood by those skilled in the art that various modifications, combinations, sub-combinations and alternations might occur depending on design requirements and other factors insofar as they are within the scope of the appended claims or the equivalents thereof.

What is claimed is:

1. A liquid crystal display, comprising:

- a data line for transmitting a data signal;
- a gate line for transmitting a gate signal;
- a data switch, electrically connected to the data line and the gate line, for providing a control of writing the data signal according to the gate signal;
- a liquid-crystal capacitor having a first end electrically connected to the data switch and a second end for receiving a liquid-crystal capacitor common voltage;
- a storage capacitor having a first end electrically connected to the data switch and a second end for receiving a storage capacitor common voltage;
- a common voltage generator, electrically connected to the liquid-crystal capacitor, for providing the liquid-crystal capacitor common voltage according to a preliminary common voltage;
- a common-voltage compensation circuit, electrically connected to the common voltage generator and the storage capacitor, for generating the storage capacitor common voltage through performing a ripple inverting operation according to the liquid-crystal capacitor common voltage, the preliminary common voltage and a compensation control signal; and
- a timing controller, electrically connected to the common-voltage compensation circuit, for analyzing an image input signal so as to generate the compensation control signal.

2. The liquid crystal display of claim 1, wherein the common-voltage compensation circuit comprises:

- a buffer, electrically connected to the common voltage generator, for outputting a preliminary storage capacitor common voltage according to the liquid-crystal capacitor common voltage;
- a high-pass filter, electrically connected to the buffer, for performing a high-pass filtering operation on the preliminary storage capacitor common voltage for extracting a first ripple voltage; and

- a ripple-voltage inverter, electrically connected to the timing controller, the high-pass filter and the storage capacitor, for performing an inverting operation on the first ripple voltage based on the preliminary common voltage and the compensation control signal so as to generate the storage capacitor common voltage having a second ripple voltage with a phase opposite to the first ripple voltage.
3. The liquid crystal display of claim 2, wherein the ripple-voltage inverter sets a peak-to-peak value ratio of the second ripple voltage to the first ripple voltage according to the compensation control signal.
4. The liquid crystal display of claim 2, wherein the buffer comprises an operational amplifier, the operational amplifier comprising:
- a non-inverting input end, electrically connected to the common voltage generator, for receiving the liquid-crystal capacitor common voltage;
 - an output end, electrically connected to the high-pass filter, for outputting the preliminary storage capacitor common voltage; and
 - an inverting input end electrically connected to the output end.
5. The liquid crystal display of claim 2, wherein the high-pass filter comprises a capacitor electrically connected between the buffer and the ripple-voltage inverter.
6. The liquid crystal display of claim 2, wherein the ripple-voltage inverter comprises:
- an operational amplifier comprising a non-inverting input end for receiving the preliminary common voltage, an output end for outputting the storage capacitor common voltage, and an inverting input end;
 - a first resistor electrically connected between the high-pass filter and the inverting input end of the operational amplifier; and
 - a resistor switching module, electrically connected between the inverting input end and the output end of the operational amplifier and electrically connected to the timing controller for receiving the compensation control signal, the resistor switching module comprising a second resistor and at least one resistor switching unit which are electrically connected in series, the resistor switching unit having a third resistor and a switch connected in parallel with the third resistor, wherein a conducting/open state of the switch is controlled by the compensation control signal.
7. The liquid crystal display of claim 1, wherein the timing controller comprises:
- an image signal analysis unit for analyzing the image input signal corresponding to a frame to be displayed so as to generate the compensation control signal with at least one bit.
8. The liquid crystal display of claim 7, wherein the image signal analysis unit is utilized for generating a gray-level variation statistical value through analyzing adjacent pixel data of the frame to be displayed, and for providing the compensation control signal according to the gray-level variation statistical value.
9. The liquid crystal display of claim 8, wherein:
- the image signal analysis unit outputs the compensation control signal having a default value when the gray-level variation statistical value is less than a threshold; and
 - the image signal analysis unit adjusts the compensation control signal in response to the gray-level variation statistical value when the gray-level variation statistical value is not less than the threshold.
10. The liquid crystal display of claim 7, wherein the image signal analysis unit is utilized for generating a black/white gray-level switching statistical value through analyzing adjacent pixel data of the frame to be displayed, and for providing the compensation control signal according to the black/white gray-level switching statistical value.
11. The liquid crystal display of claim 10, wherein:
- the image signal analysis unit outputs the compensation control signal having a default value when the black/white gray-level switching statistical value is less than a threshold; and
 - the image signal analysis unit adjusts the compensation control signal in response to the black/white gray-level switching statistical value when the black/white gray-level switching statistical value is not less than the threshold.
12. The liquid crystal display of claim 1, further comprising:
- a voltage dividing unit, electrically connected to the common-voltage compensation circuit and the common voltage generator, for performing a voltage dividing operation on a power voltage so as to generate the preliminary common voltage.
13. A common-voltage compensation method for use in a liquid crystal display having a liquid-crystal capacitor and a storage capacitor, the common-voltage compensation method comprising:
- providing a liquid-crystal capacitor common voltage furnished to the liquid-crystal capacitor according to a preliminary common voltage;
 - generating a preliminary storage capacitor common voltage according to the liquid-crystal capacitor common voltage;
 - performing a high-pass filtering operation on the preliminary storage capacitor common voltage for extracting a first ripple voltage;
 - analyzing an image input signal for generating a compensation control signal;
 - performing an inverting operation on the first ripple voltage based on the preliminary common voltage and the compensation control signal so as to generate a storage capacitor common voltage having a second ripple voltage with a phase opposite to the first ripple voltage; and
 - furnishing the storage capacitor common voltage to the storage capacitor.
14. The common-voltage compensation method of claim 13, wherein the step of performing the inverting operation on the first ripple voltage based on the preliminary common voltage and the compensation control signal so as to generate the storage capacitor common voltage having the second ripple voltage with a phase opposite to the first ripple voltage comprises:
- setting a peak-to-peak value ratio of the second ripple voltage to the first ripple voltage according to the compensation control signal.
15. The common-voltage compensation method of claim 13, wherein the step of analyzing the image input signal for generating the compensation control signal comprises:
- analyzing the image input signal corresponding to a frame to be displayed so as to generate the compensation control signal.

16. The common-voltage compensation method of claim **15**, wherein the step of analyzing the image input signal corresponding to the frame to be displayed so as to generate the compensation control signal comprises:

- generating a gray-level variation statistical value through analyzing adjacent pixel data of the frame to be displayed; and
- providing the compensation control signal according to the gray-level variation statistical value.

17. The common-voltage compensation method of claim **16**, wherein the step of providing the compensation control signal according to the gray-level variation statistical value comprises:

- setting the compensation control signal to be a default value when the gray-level variation statistical value is less than a threshold; and
- adjusting the compensation control signal in response to the gray-level variation statistical value when the gray-level variation statistical value is not less than the threshold.

18. The common-voltage compensation method of claim **15**, wherein the step of analyzing the image input signal corresponding to the frame to be displayed so as to generating the compensation control signal comprises:

- generating a black/white gray-level switching statistical value through analyzing adjacent pixel data of the frame to be displayed; and
- providing the compensation control signal according to the black/white gray-level switching statistical value.

19. The common-voltage compensation method of claim **18**, wherein the step of providing the compensation control signal according to the black/white gray-level switching statistical value comprises:

- setting the compensation control signal to be a default value when the black/white gray-level switching statistical value is less than a threshold; and
- adjusting the compensation control signal in response to the black/white gray-level switching statistical value when the black/white gray-level switching statistical value is not less than the threshold.

* * * * *

专利名称(译)	具有共电压补偿机制和共电压补偿方法的液晶显示器		
公开(公告)号	US20130249966A1	公开(公告)日	2013-09-26
申请号	US13/902852	申请日	2013-05-26
[标]申请(专利权)人(译)	友达光电股份有限公司		
申请(专利权)人(译)	友达光电.		
当前申请(专利权)人(译)	友达光电.		
[标]发明人	LI CHING LIN LIN YI FAN CHEN JEN CHIEH		
发明人	LI, CHING-LIN LIN, YI-FAN CHEN, JEN-CHIEH		
IPC分类号	G09G3/36		
CPC分类号	G09G3/3607 G09G3/36 G09G2320/0257 G09G3/3696 G09G2320/0209 G09G3/3655		
优先权	100117195 2011-05-17 TW		
其他公开文献	US8928705		
外部链接	Espacenet USPTO		

摘要(译)

具有共用电压补偿机构的液晶显示器包括用于接收液晶电容器公共电压的液晶电容器公共电极，用于接收存储电容器公共电压的存储电容器公共电极，用于提供液晶的公共电压发生器电容器公共电压根据初步公共电压，公共电压补偿电路电连接到液晶电容器公共电极和存储电容器公共电极，并且时序控制器电连接到公共电压补偿电路。公共电压补偿电路用于通过根据液晶电容器公共电压，初级公共电压和补偿控制信号执行纹波反转操作来产生存储电容器公共电压。时序控制器用于分析图像输入信号以产生补偿控制信号。

