



US008199301B2

(12) **United States Patent**
Oh et al.

(10) **Patent No.:** **US 8,199,301 B2**
(45) **Date of Patent:** **Jun. 12, 2012**

(54) **HORIZONTAL ELECTRIC FIELD SWITCHING LIQUID CRYSTAL DISPLAY DEVICE**

(75) Inventors: **Jae Young Oh**, Gyeonggi-do (KR);
Sung Jin Hong, Seoul (KR)

(73) Assignee: **LG Display Co., Ltd.**, Seoul (KR)

(*) Notice: Subject to any disclaimer, the term of this patent is extended or adjusted under 35 U.S.C. 154(b) by 0 days.

(21) Appl. No.: **13/006,391**

(22) Filed: **Jan. 13, 2011**

(65) **Prior Publication Data**
US 2011/0109827 A1 May 12, 2011

Related U.S. Application Data

(62) Division of application No. 11/451,484, filed on Jun. 13, 2006, now Pat. No. 7,872,721.

(51) **Int. Cl.**
G02F 1/1343 (2006.01)

(52) **U.S. Cl.** **349/141**; 349/38; 349/39

(58) **Field of Classification Search** 349/141,
349/38, 39

See application file for complete search history.

(56) **References Cited**

U.S. PATENT DOCUMENTS

4,648,933	A *	3/1987	Graziano	156/361
6,486,933	B1 *	11/2002	Cha et al.	349/139
2003/0058396	A1	3/2003	Shih	
2003/0160921	A1	8/2003	Nakashima et al.	
2004/0183976	A1 *	9/2004	Nagano et al.	349/141
2004/0263751	A1 *	12/2004	Kim et al.	349/141
2005/0030459	A1 *	2/2005	Song et al.	349/129
2005/0094079	A1	5/2005	Yoo et al.	

* cited by examiner

Primary Examiner — Lauren Nguyen

(74) *Attorney, Agent, or Firm* — Morgan, Lewis & Bockius LLP

(57) **ABSTRACT**

A horizontal electric field switching liquid crystal display device includes a gate line, a common line parallel to the gate line and provided at an area adjacent to the gate line, a data line crossing the gate line with a gate insulating film therebetween to define a pixel area, a thin film transistor provided adjacent to a crossing of the gate line and the data line, a common electrode provided in the pixel area and connected to the common line, a pixel electrode connected to the thin film transistor and provided in such a manner to form a horizontal electric field along with the common electrode in the pixel area on the same plane as the common electrode, a storage capacitor electrode overlapping the common electrode to provide a storage capacitor, and a contact electrode contacting the pixel electrode, the thin film transistor and the storage electrode at their side surfaces.

9 Claims, 26 Drawing Sheets

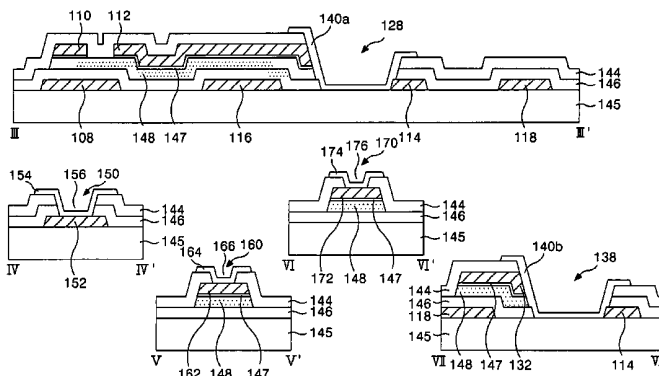
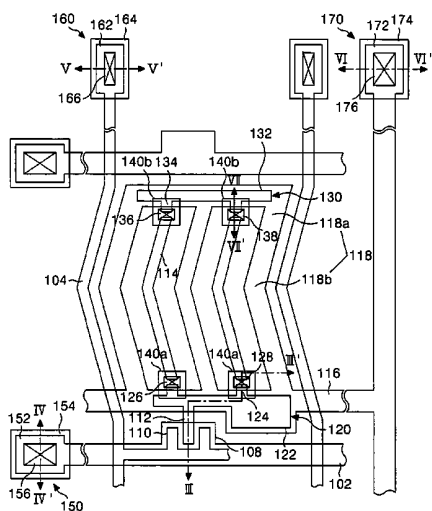

FIG. 1
RELATED ART

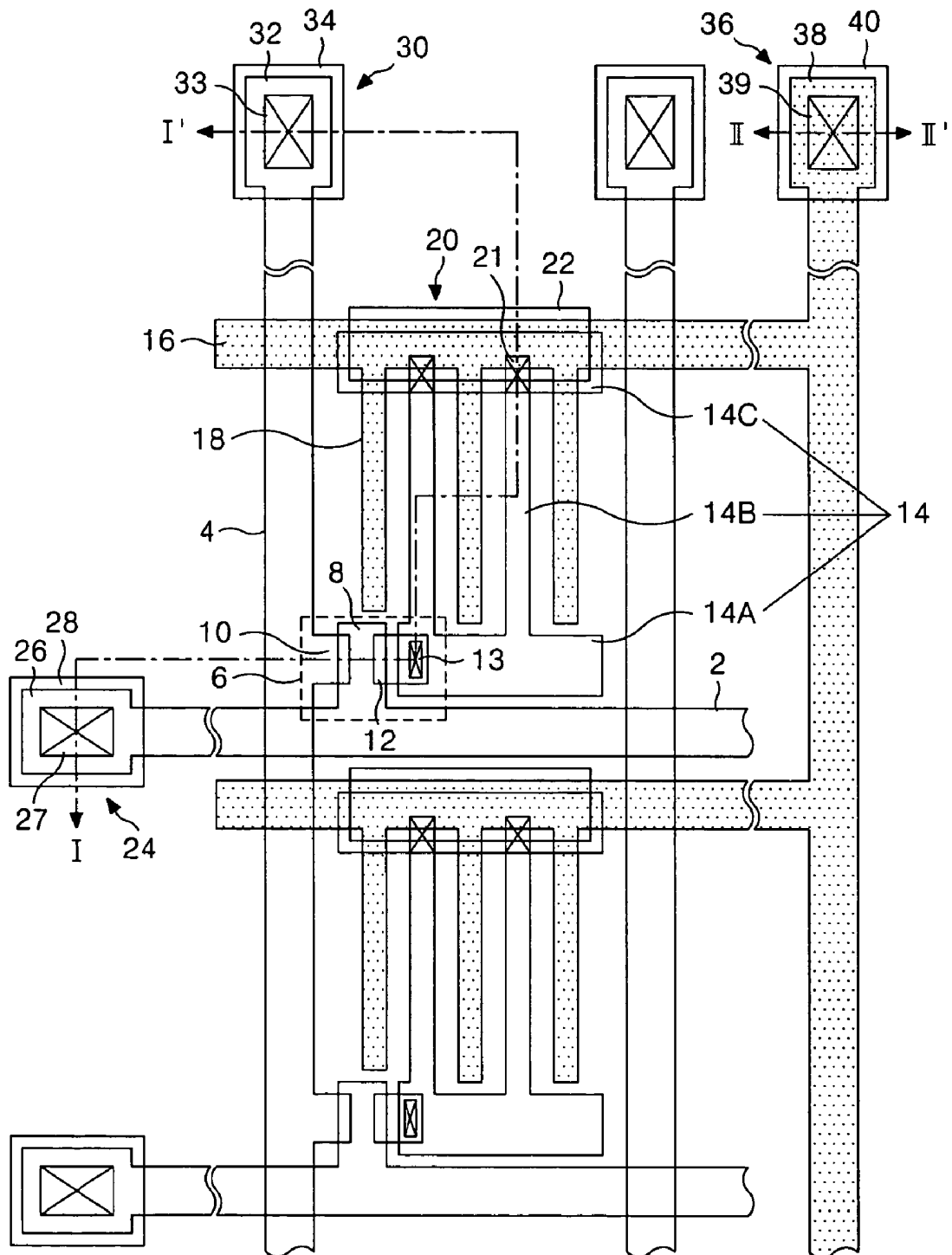

FIG. 2
RELATED ART

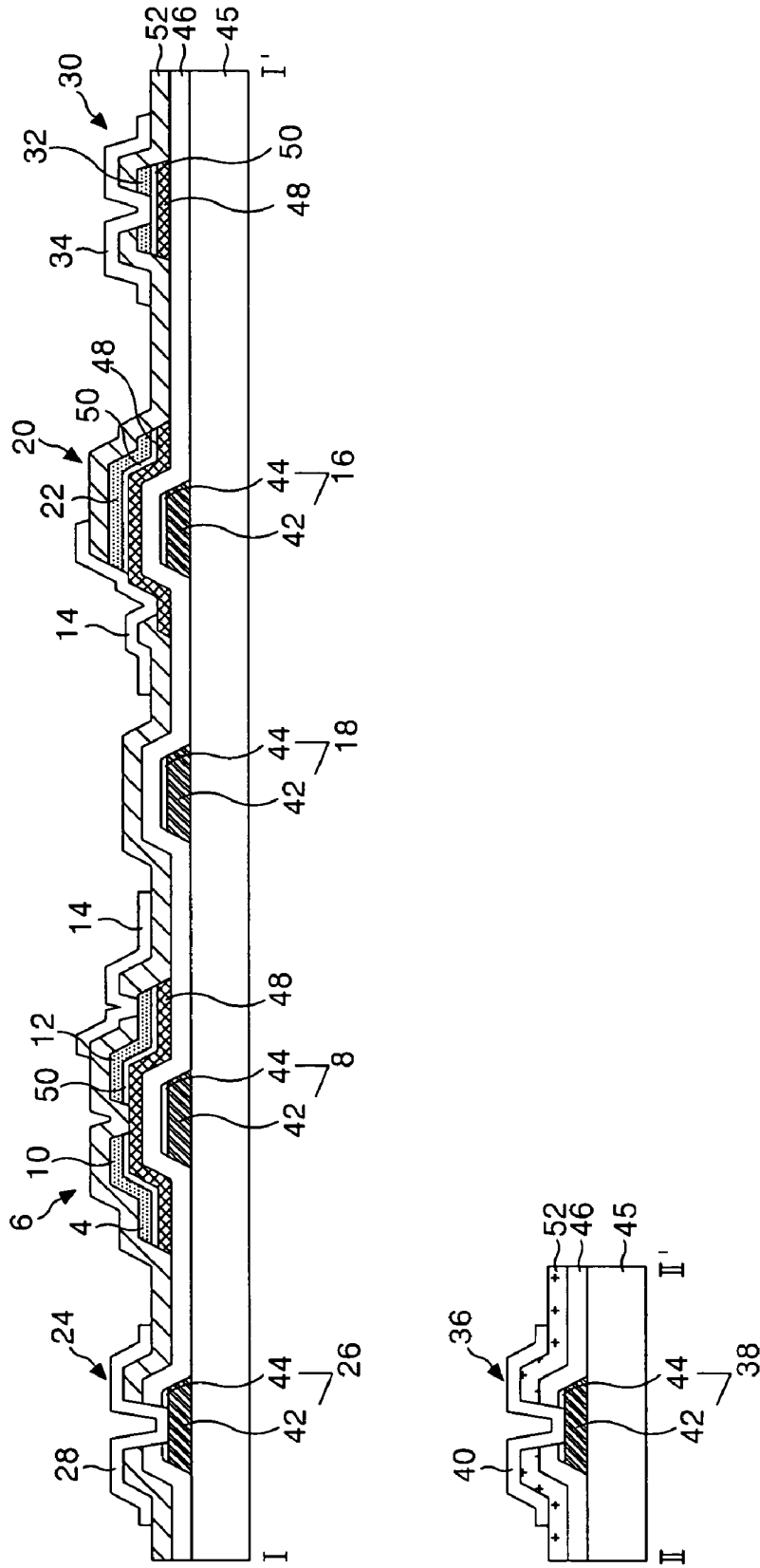

FIG. 3A
RELATED ART

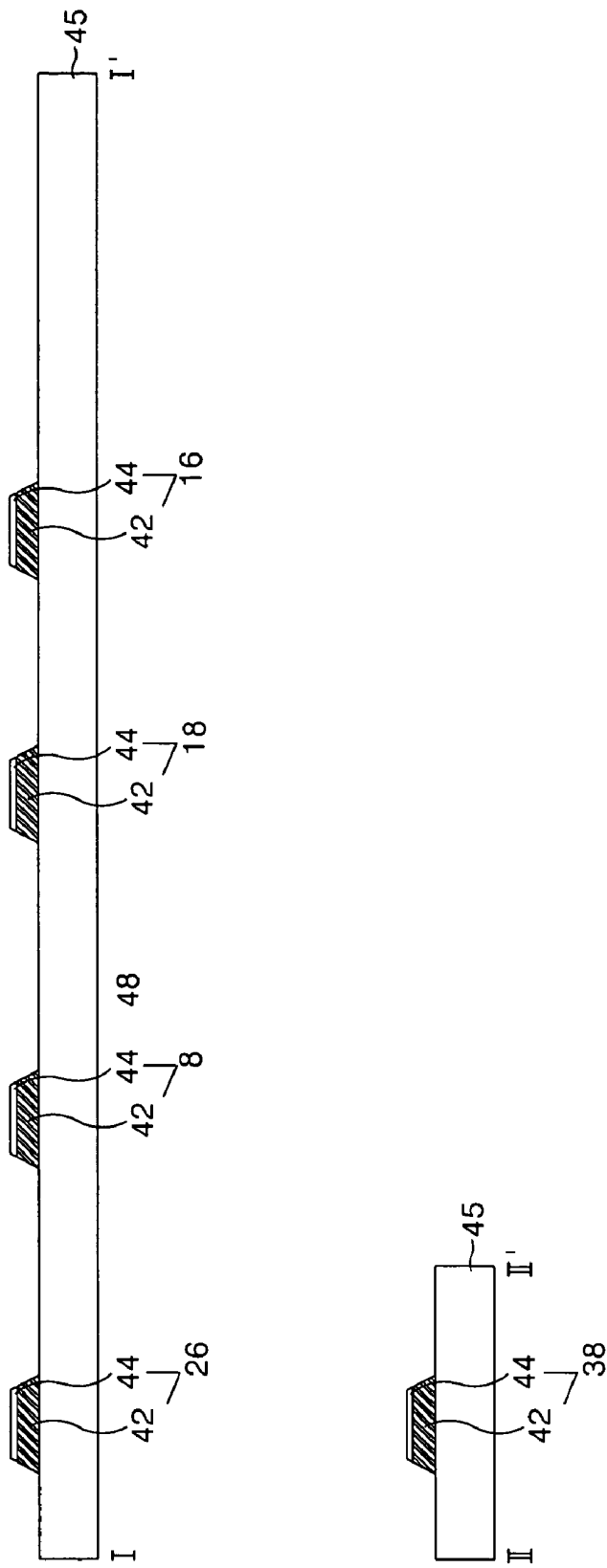

FIG. 3B
RELATED ART

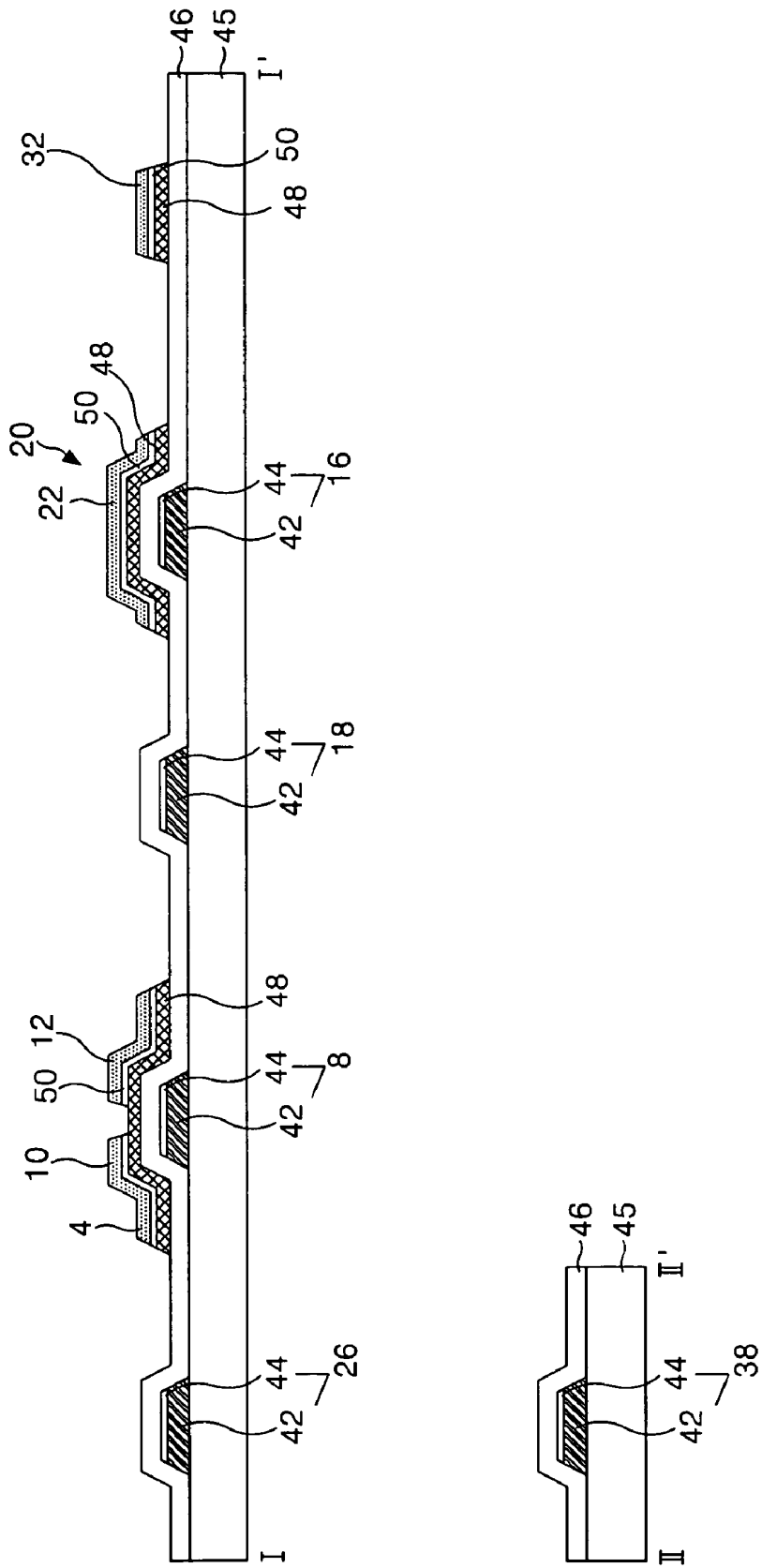

FIG. 3C
RELATED ART

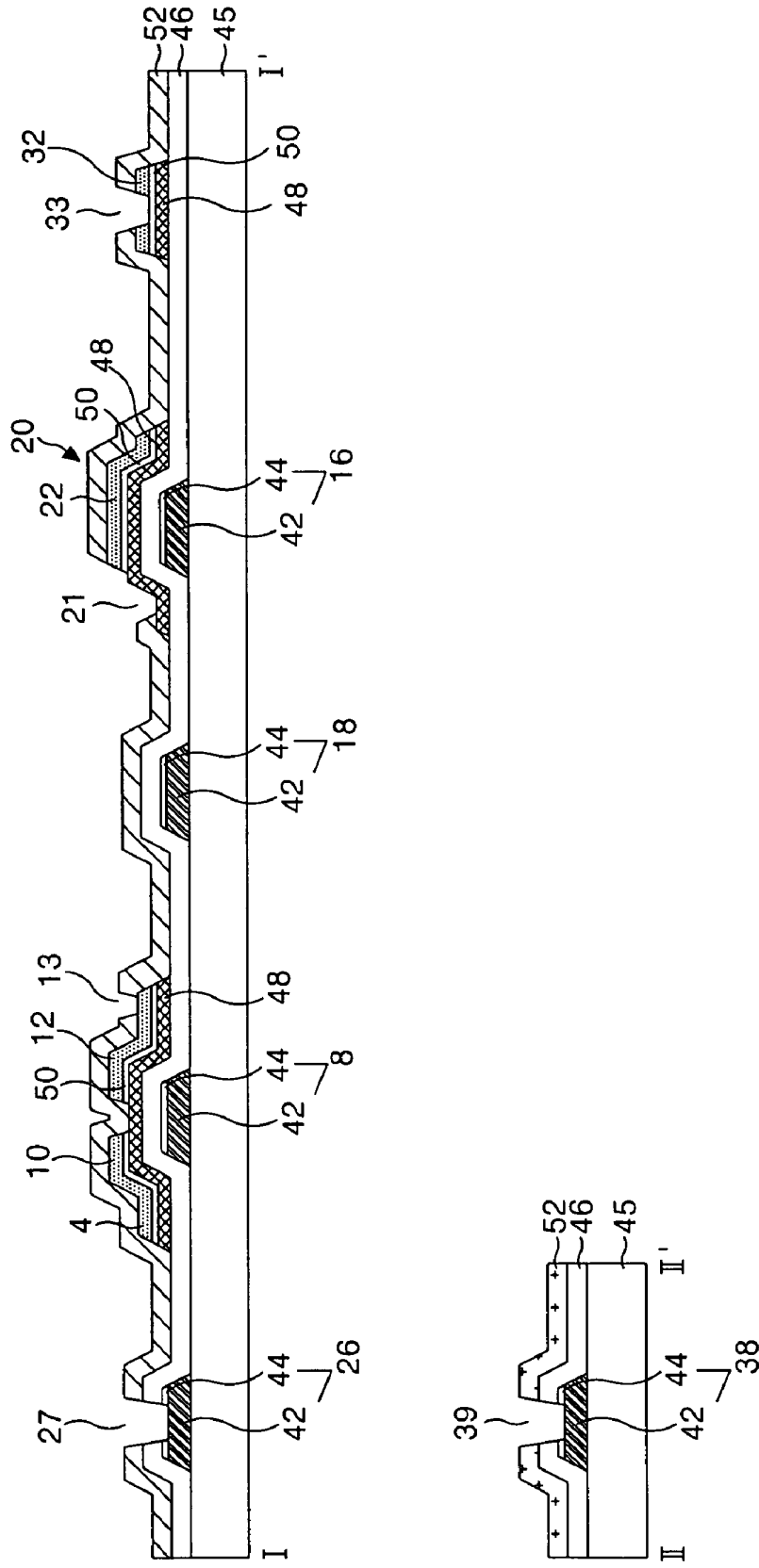

FIG. 3D
RELATED ART

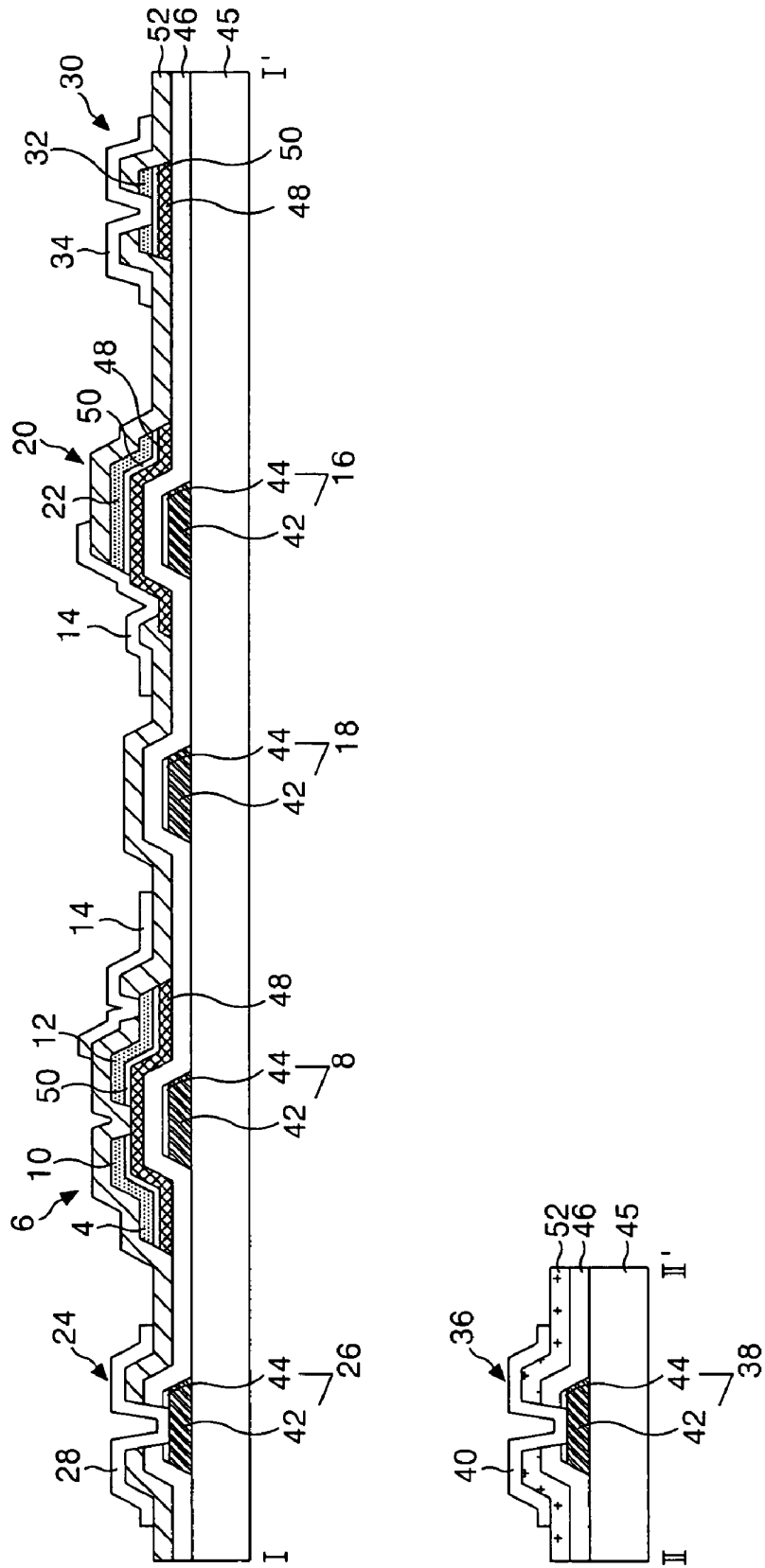

FIG. 4

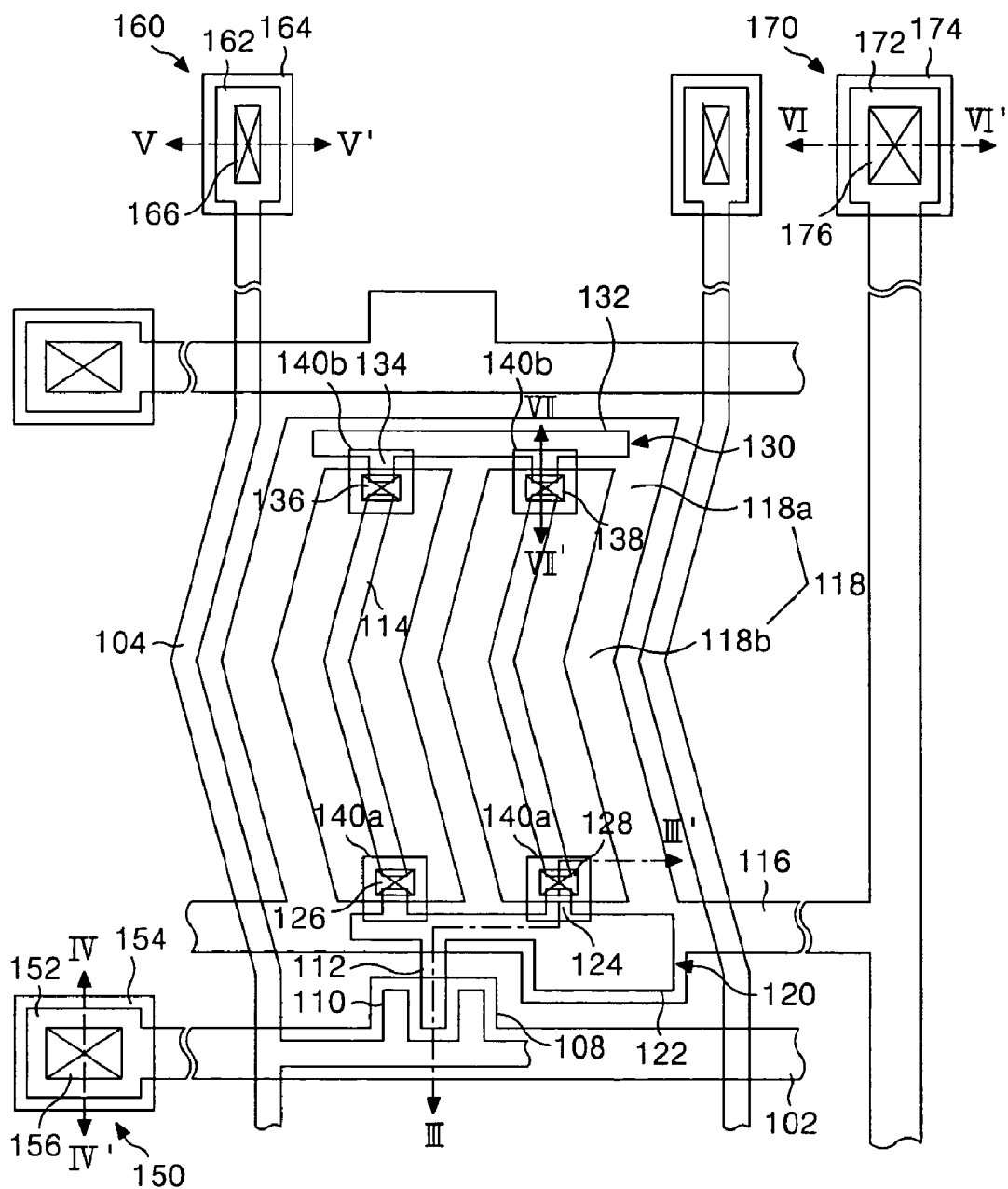

FIG. 6A

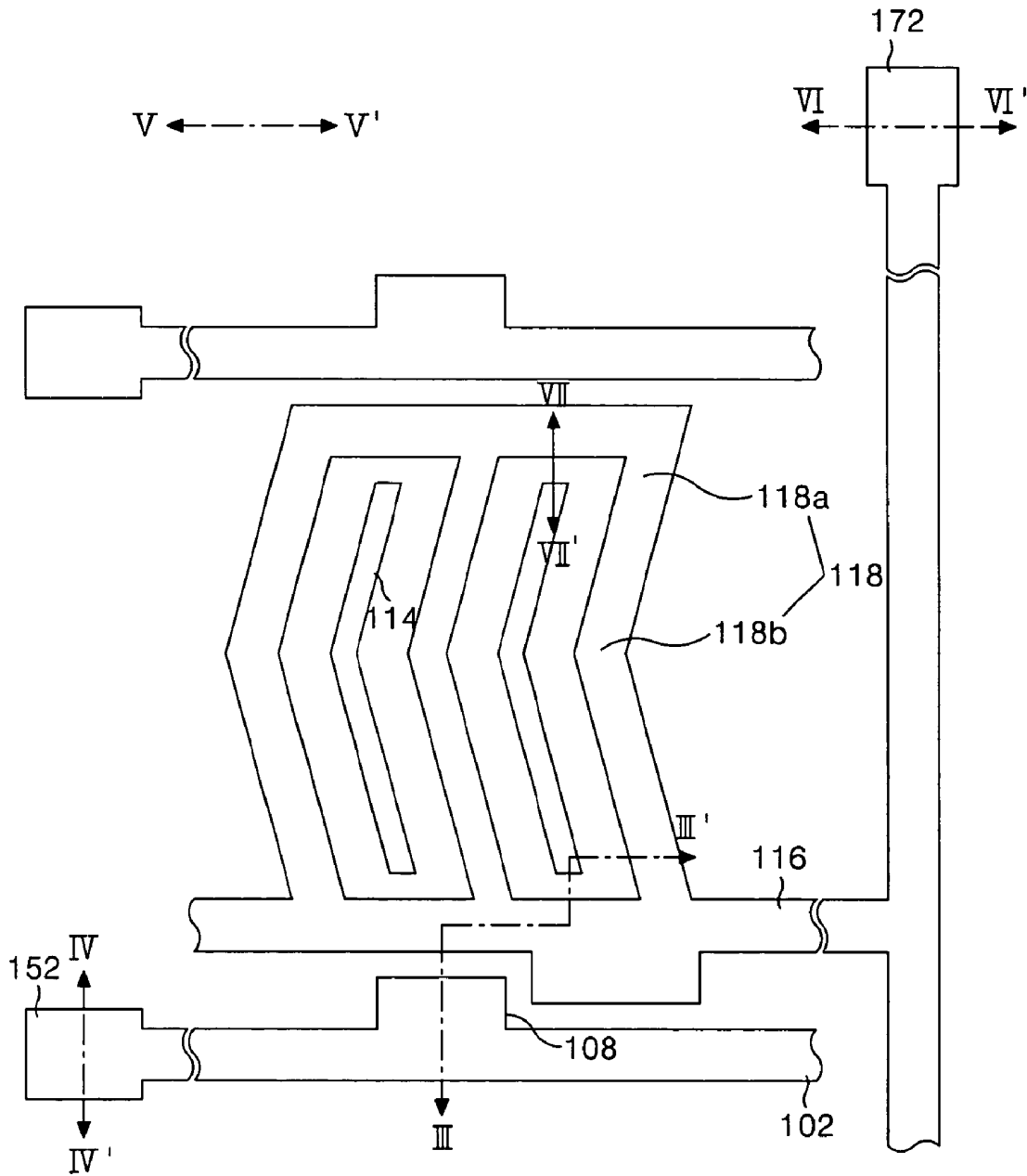

FIG. 7A

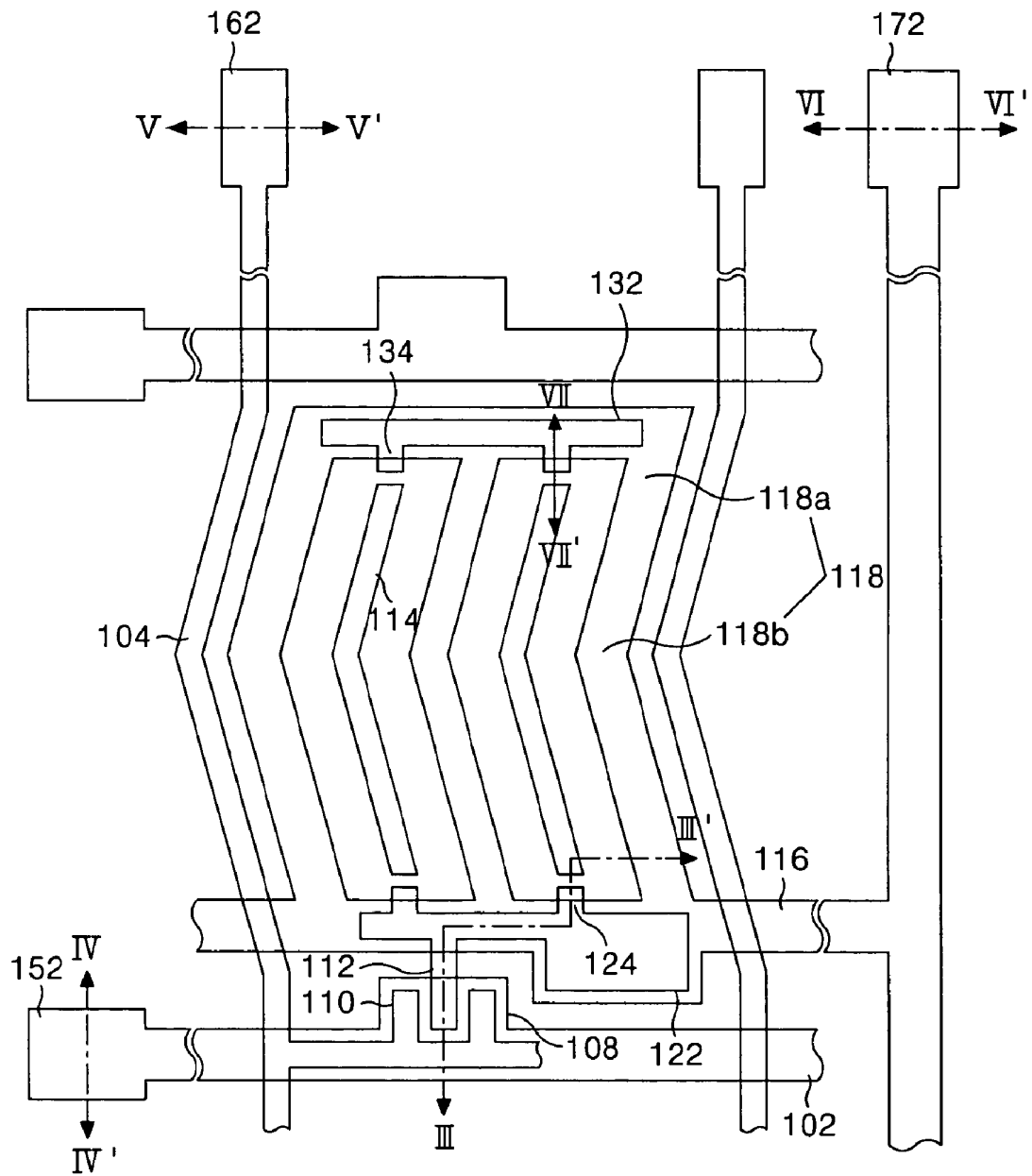

FIG. 8A

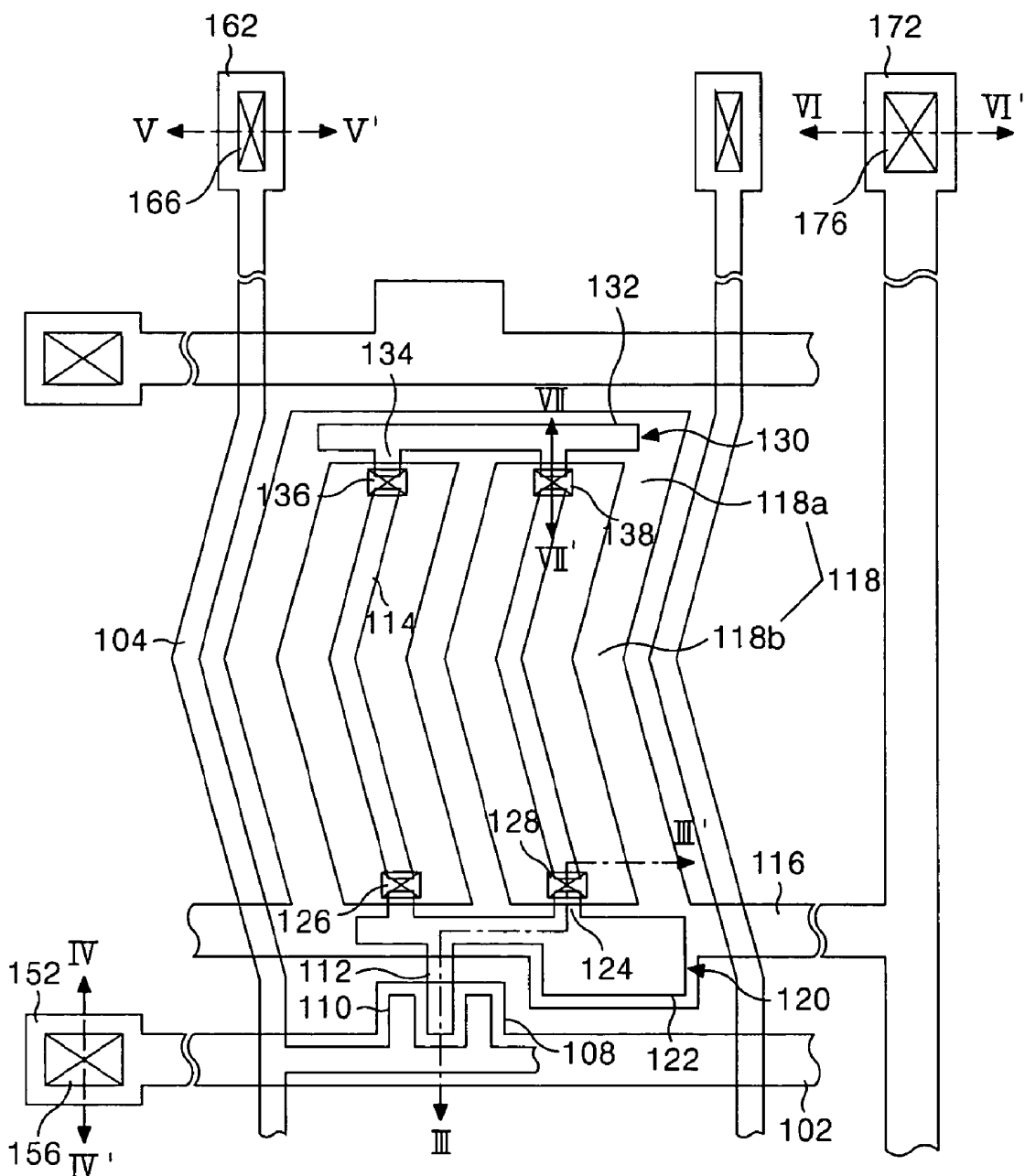

FIG. 9A

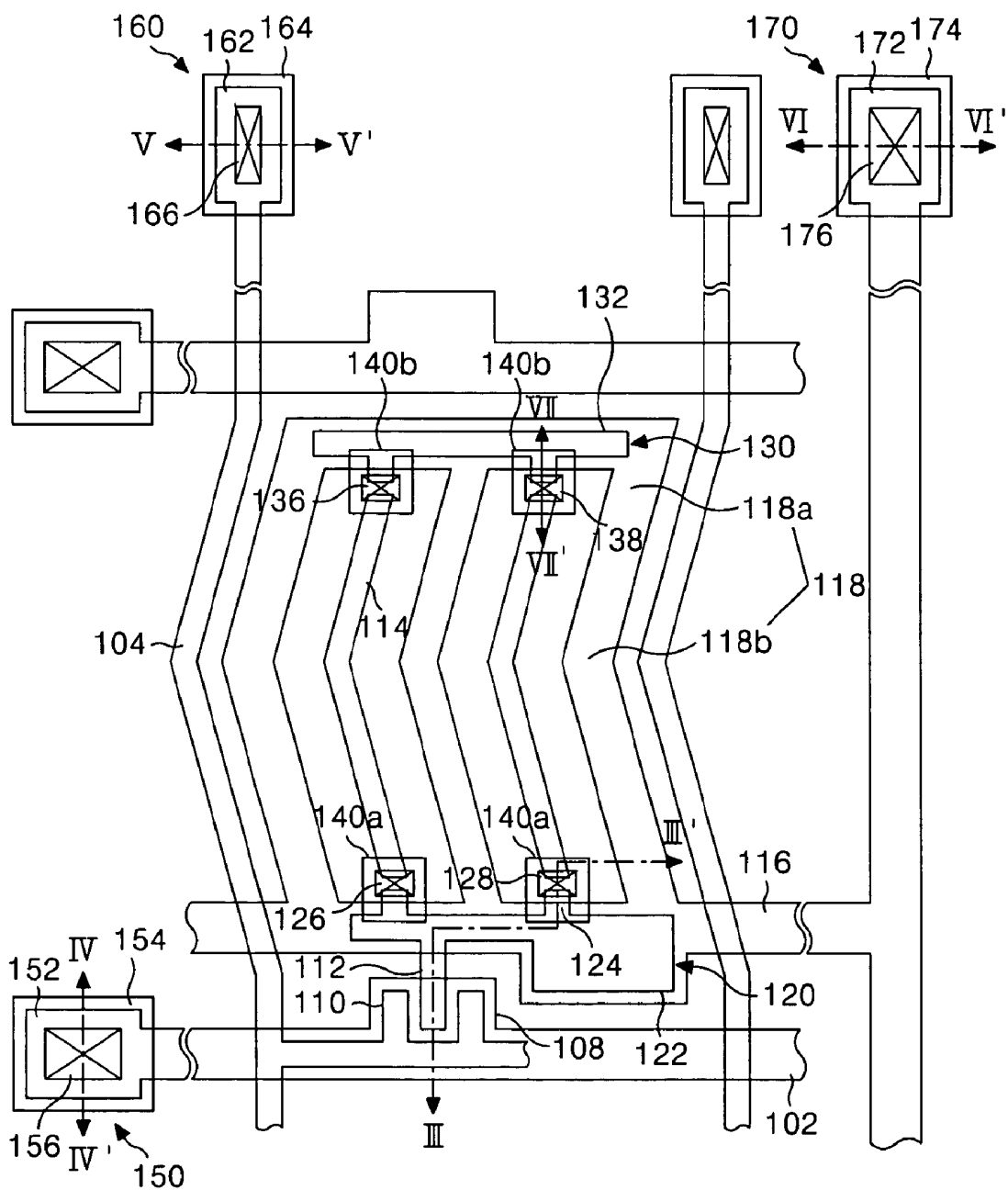

FIG. 10A

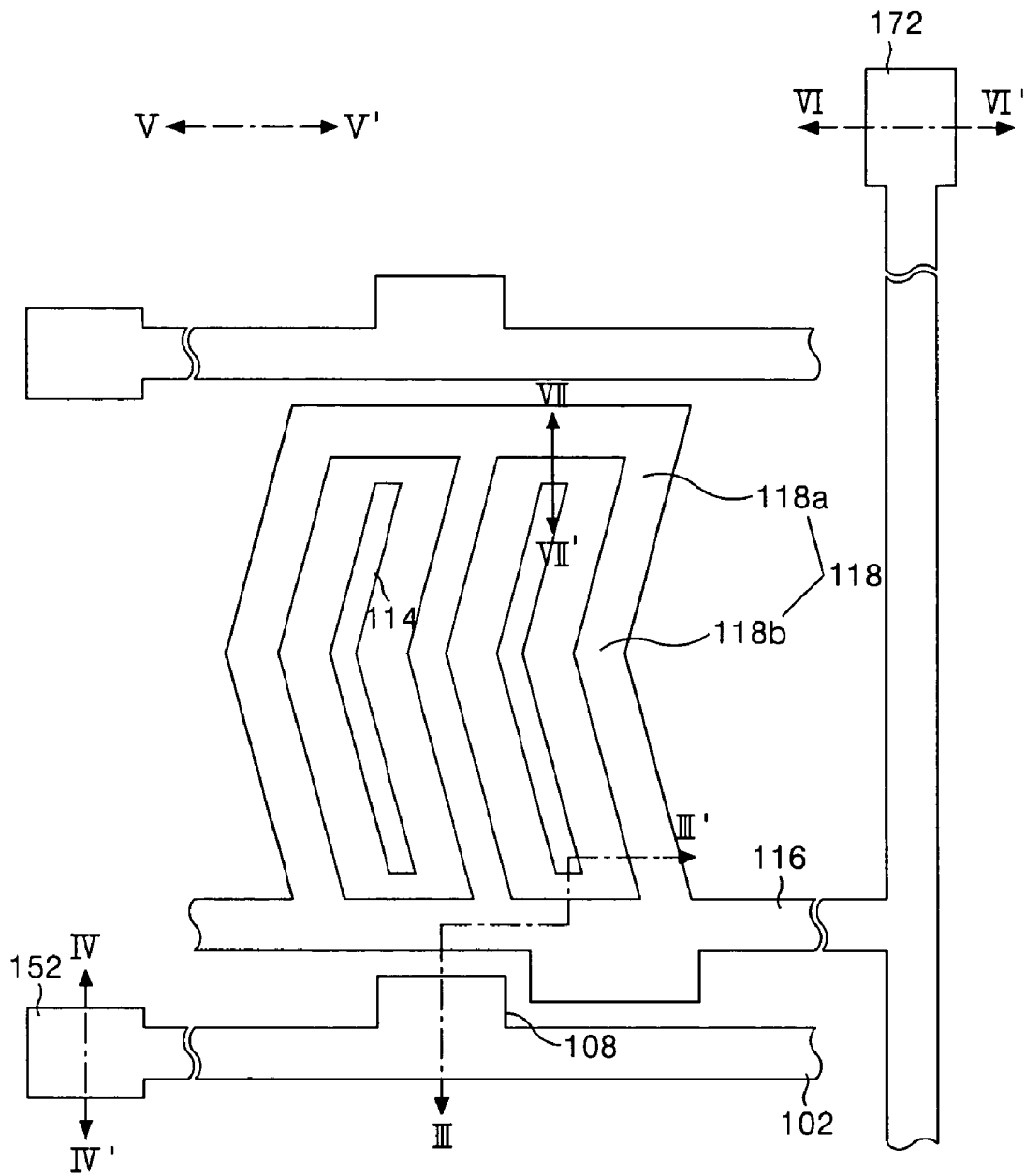

FIG. 10B

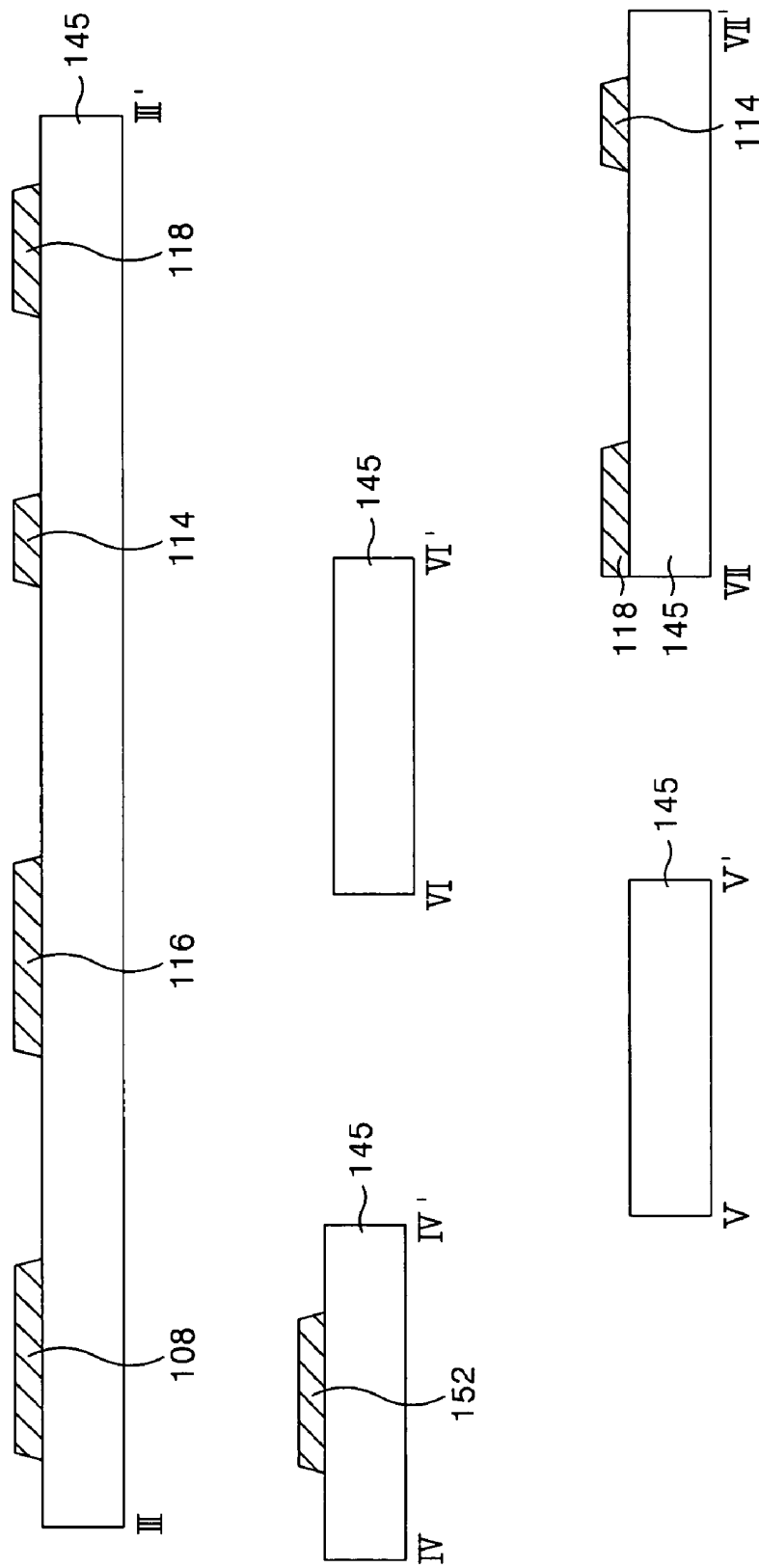

FIG. 11A

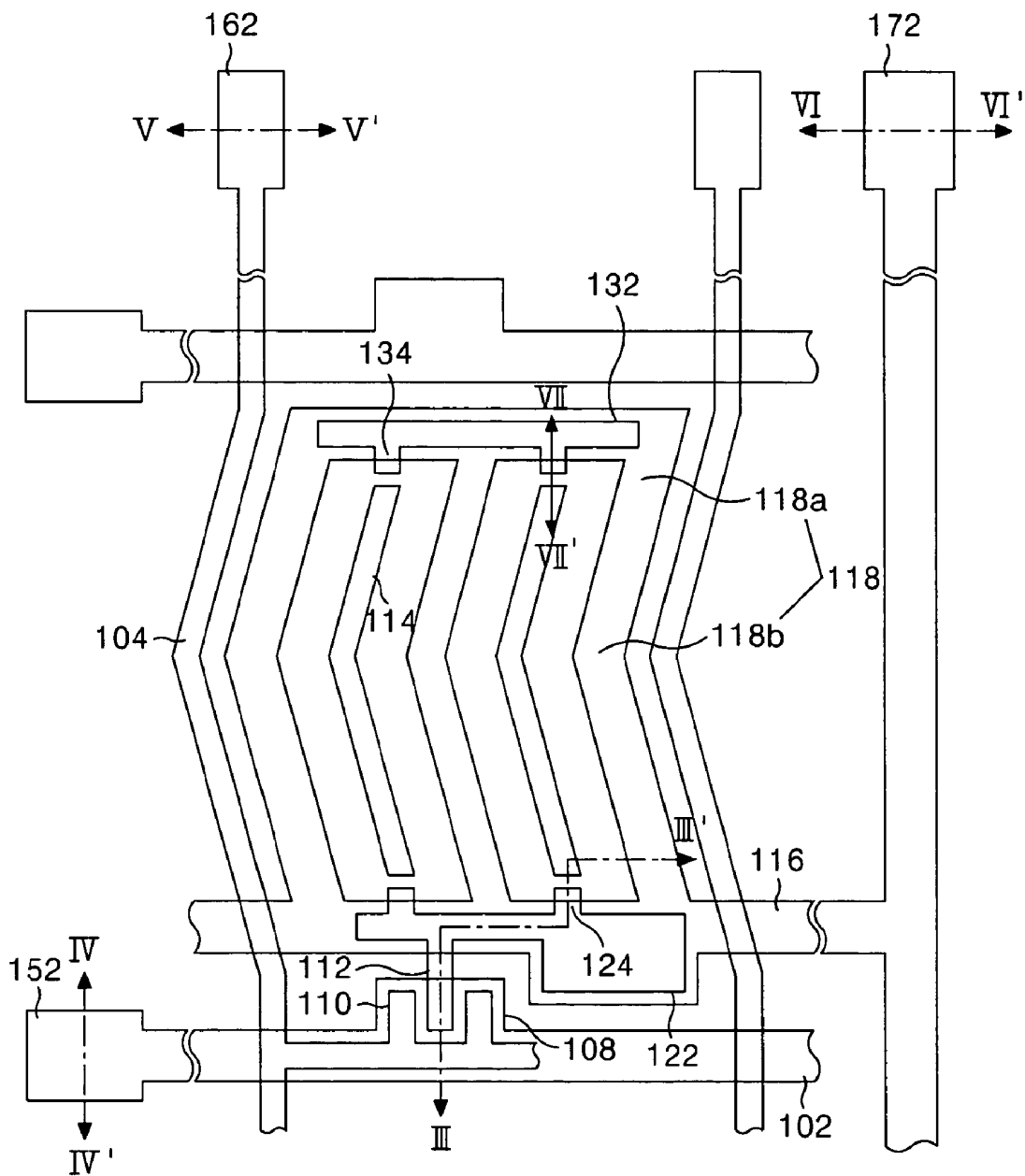

FIG. 11B

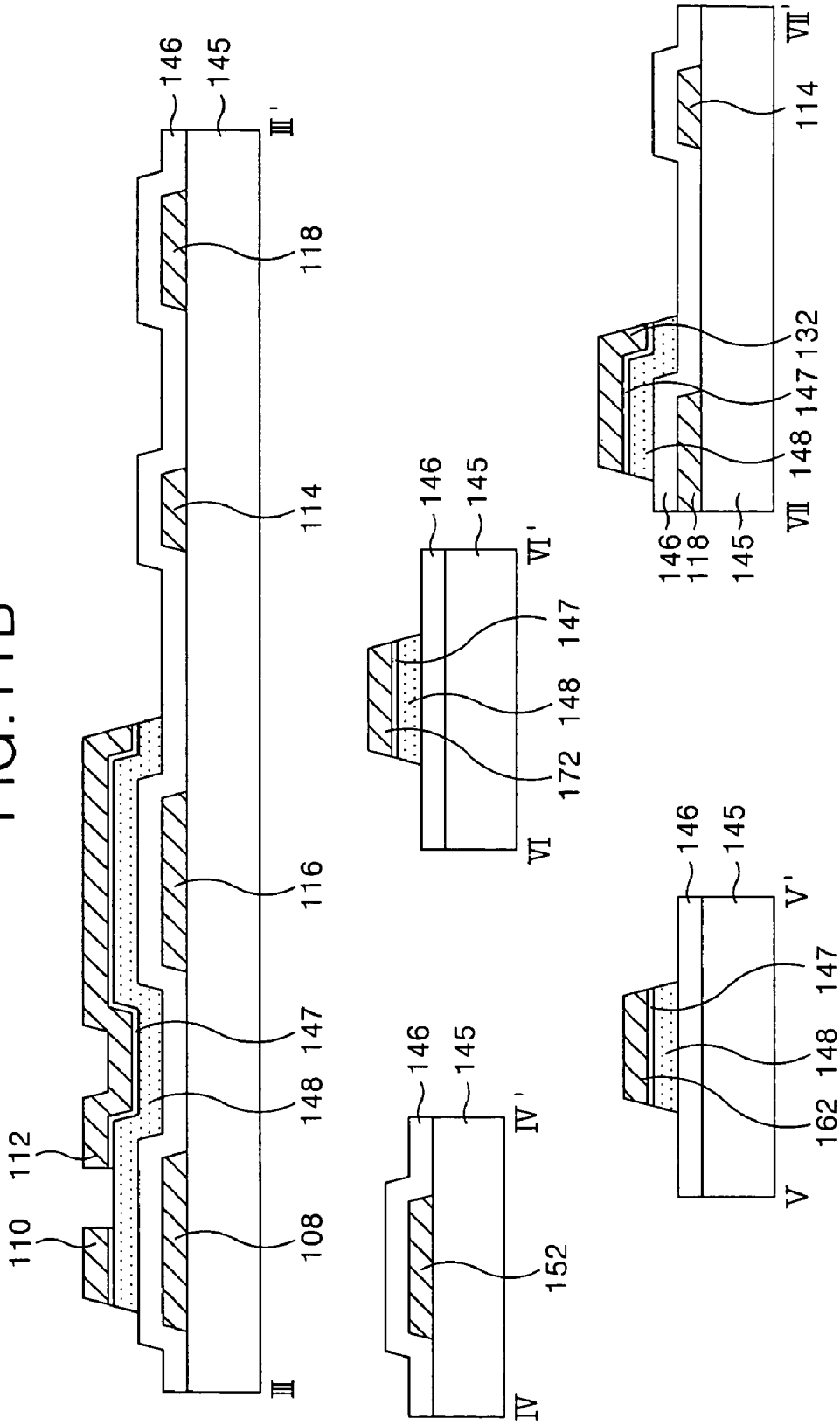

FIG. 12A

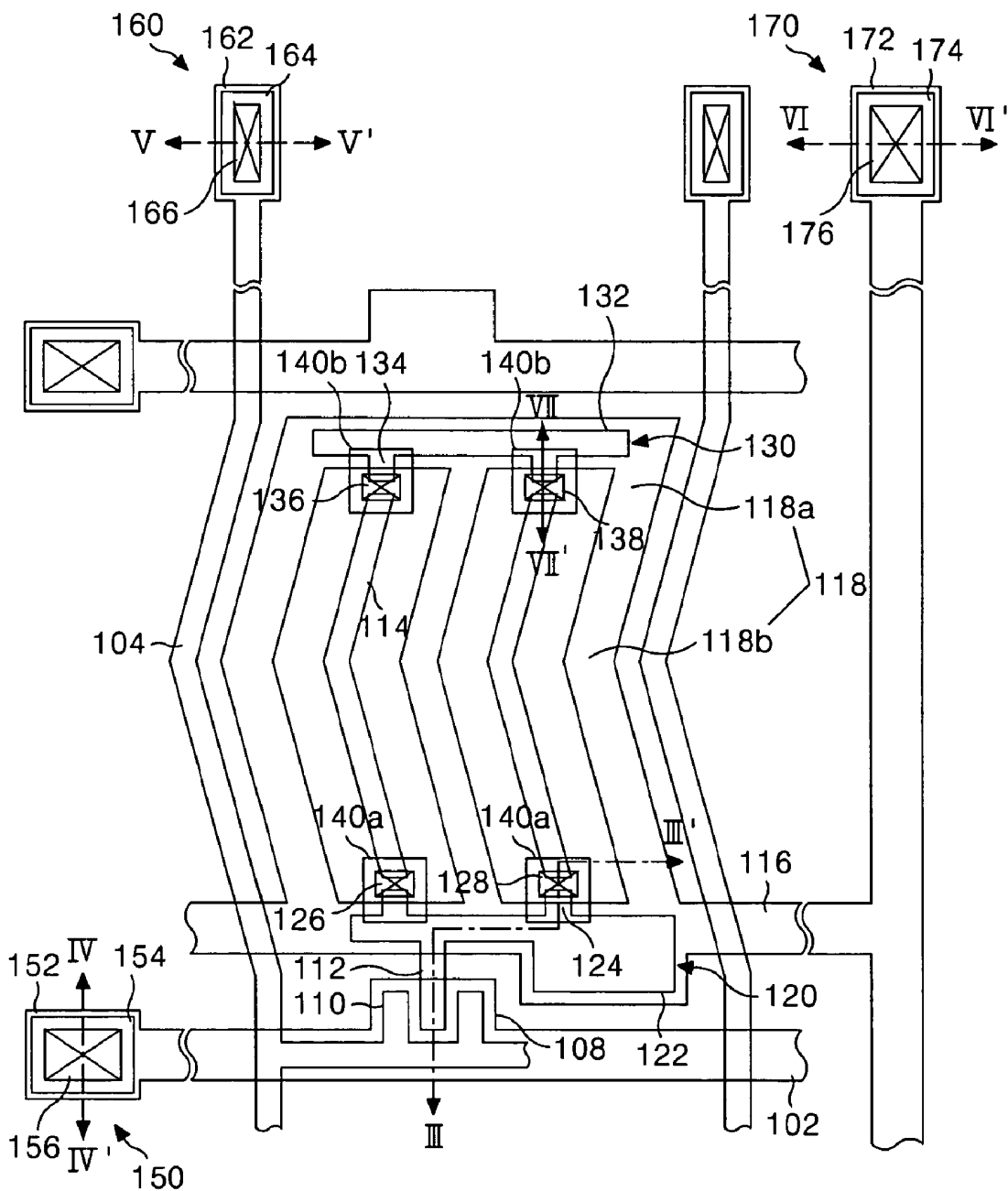

FIG. 12B

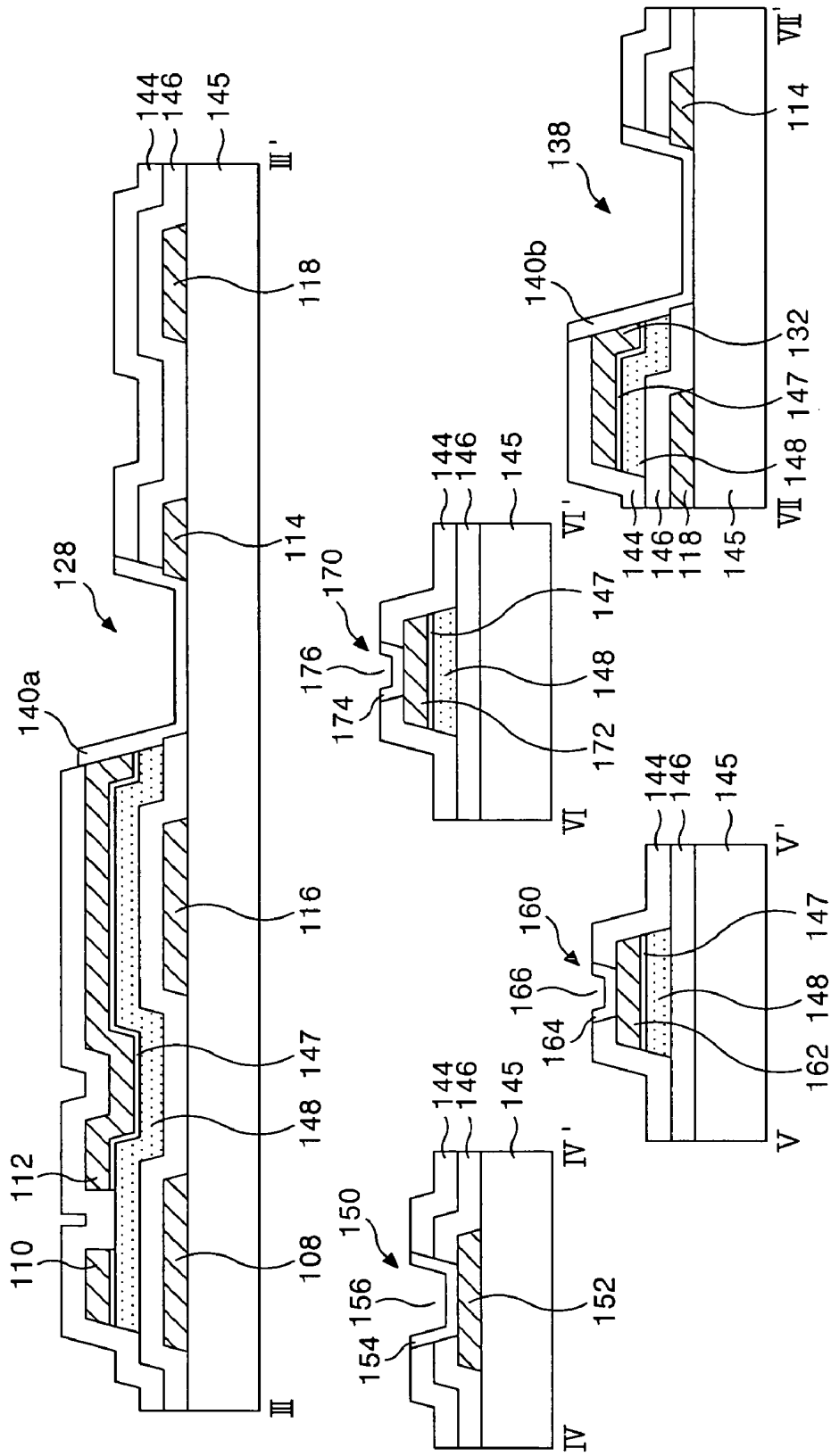

FIG. 13A

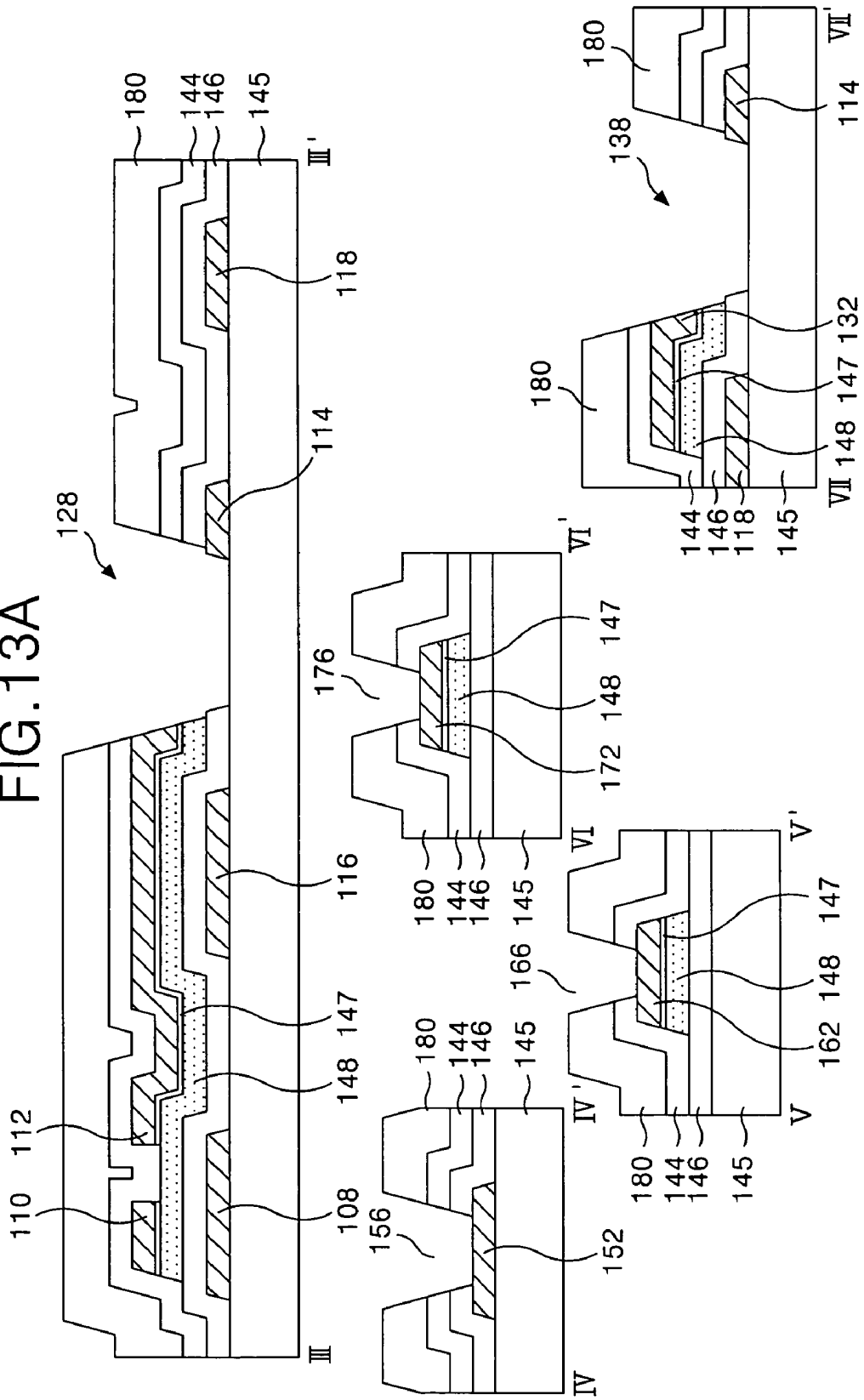

FIG. 13B

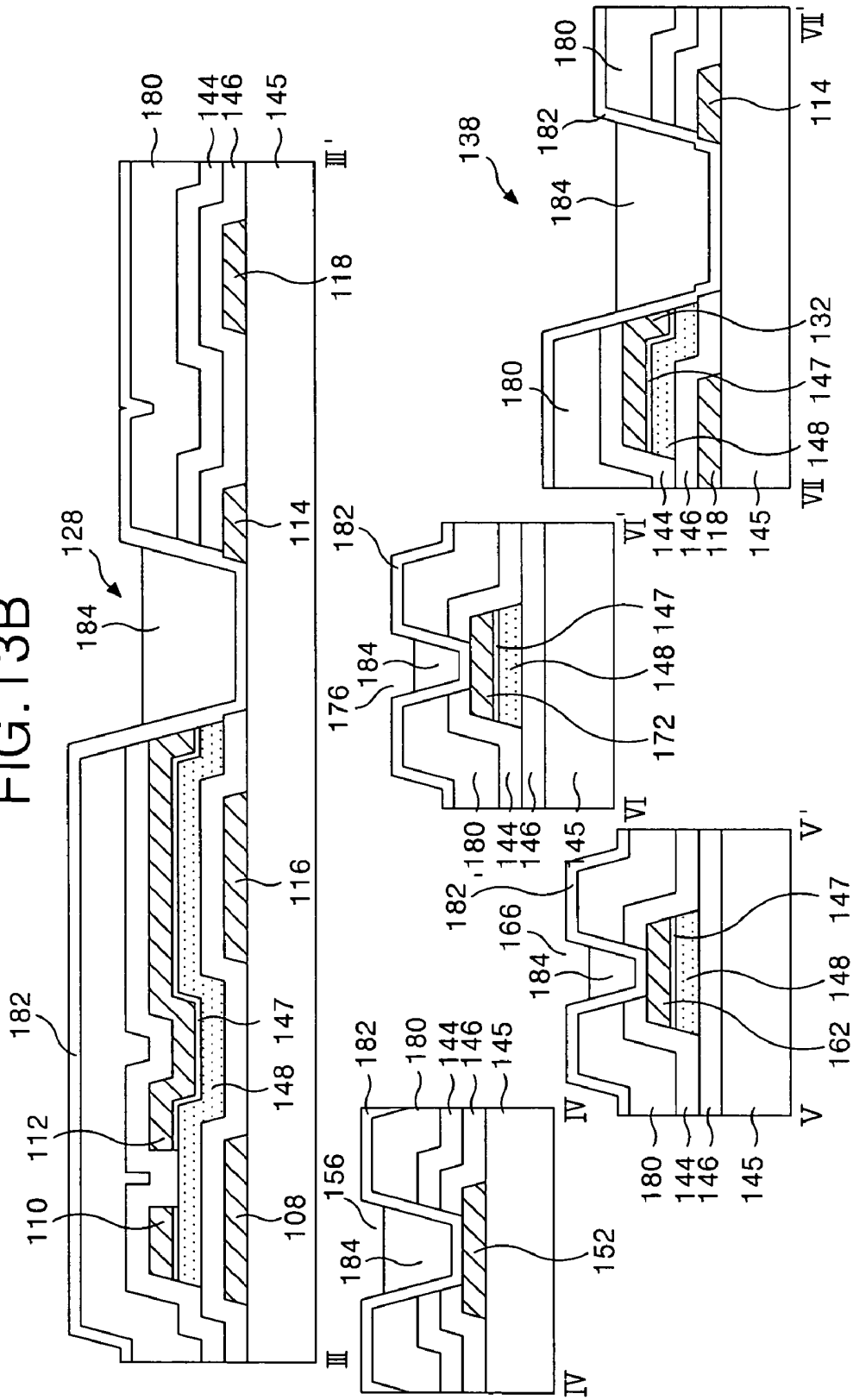
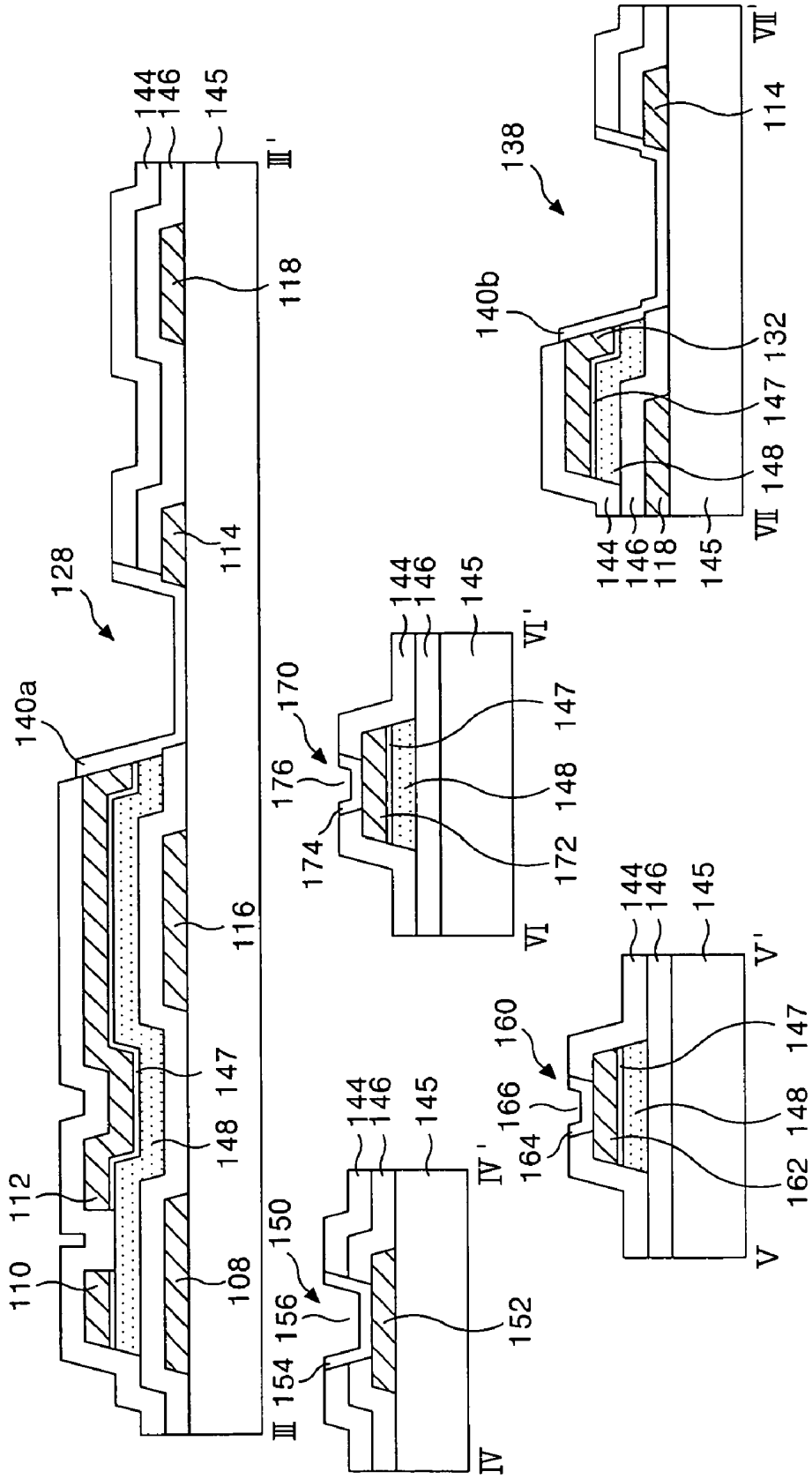

FIG. 13D



HORIZONTAL ELECTRIC FIELD SWITCHING LIQUID CRYSTAL DISPLAY DEVICE

This application is a divisional application of application Ser. No. 11/451,484, filed Jun. 13, 2006 now U.S. Pat. No. 7,872,721, and also claims the benefit of Korean Patent Application No. P2005-0056560 filed in Korea on Jun. 28, 2005, both of which are hereby incorporated by reference in their entirety.

BACKGROUND OF THE INVENTION

1. Field of the Invention

This invention relates to a liquid crystal display device, and more particularly to a horizontal electric field switching liquid crystal display device and a fabricating method thereof. Although the present invention is suitable for a wide scope of applications, it is particularly suitable for a horizontal electric field switching liquid crystal display (LCD) device formed using a reduced number of masking processes having increased capacitance.

2. Description of the Related Art

Generally, a liquid crystal display device controls light transmittance of a liquid crystal molecules having a dielectric anisotropy using an electric field to thereby display a picture. The liquid crystal molecules are positioned between upper and lower substrates. Such LCD devices are classified as either a vertical electric field switching type or a horizontal electric field switching type depending upon the direction of the electric field driving the liquid crystal molecules.

The LCD device of the vertical electric field switching type can drive the liquid crystal molecules in a twisted nematic (TN) mode with a vertical electric field formed between a pixel electrode and a common electrode arranged in opposition to each other on the upper and lower substrates. Such a TN mode LCD device has the advantage of a large aperture ratio. However, the TN mode LCD device has the drawback of a narrow viewing angle that is about 90°.

The LCD device of a horizontal electric field switching type can drive the liquid crystal molecules in an in-plane switching (IPS) mode or with a horizontal electric field between the pixel electrode and the common electrode arranged in parallel to each other on the lower substrate. Such an IPS mode LCD device has the advantage of a wide viewing angle, which is about 160°. Hereinafter, a related art IPS mode LCD device will be described in detail.

A related art IPS mode LCD device includes a thin film transistor array substrate (lower substrate) and a color filter array substrates (upper substrate) that are opposed to each other, a spacer for constantly keeping a cell gap between the two substrates, and a layer of liquid crystal molecules within the cell gap. The thin film transistor array substrate includes a plurality of signal wirings and thin film transistors, and an upper alignment film coated thereon to align the liquid crystal molecules. The color filter array substrate includes a color filter for implementing color, a black matrix for preventing light leakage and an upper alignment film coated thereon to align the liquid crystal molecules.

Fabrication of the thin film transistor array substrate includes semiconductor processes that require a plurality of mask processes. Each of the mask processes are complicated fabricating processes that add to the manufacturing cost of the liquid crystal display panel. One mask process includes many process steps, such as thin film deposition, cleaning, photolithography, etching, photo-resist stripping and an inspection processes. To reduce manufacturing cost, a thin film transistor

array substrate has been developed, which can be made with a reduced number of mask processes. For example, reducing a standard five-round mask process for forming a thin film transistor substrate to a four-round mask process for forming a thin film transistor array substrate has been suggested recently.

FIG. 1 is a plan view showing a portion of a thin film transistor array substrate of an IPS mode liquid crystal display device formed by a related art four-round mask process, and FIG. 2 is a cross-sectional view of the thin film transistor array substrate along the lines I-I' and II-II' in FIG. 1. As shown in FIG. 1 and FIG. 2, the thin film transistor array substrate includes a gate line 2 and a data line 4 provided on a lower substrate 45 in such a manner to cross each other with a gate insulating film 46 therebetween. A thin film transistor 6 is formed at each crossing of a gate line 2 and a data line 4. A pixel electrode 14 and a common electrode 18 are formed in such a manner on the thin film transistor array substrate to provide a horizontal electric field in a pixel area defined by the gate line 2 and a data line 4. A common line 16 is connected to the common electrode 18. A storage capacitor 20 is formed by a portion of the pixel electrode 14 that overlaps a common electrode line 16. A gate pad 24 is connected to the gate line 2. A data pad 33 is connected to the data line 4. A common pad 36 is connected to the common line 16.

The data line 4 supplies a data signal to the pixel electrode 14 through the thin film transistor 6 while the gate line 2 supplies a gate signal. More specifically, the thin film transistor 6 allows a pixel signal applied to the data line 4 to be charged onto the pixel electrode 14 in response to a scanning signal applied to the gate line 2. The common line 16 supplies a reference voltage for driving the liquid crystal and is formed in parallel to the gate line 2.

The thin film transistor 6 includes a gate electrode 8 connected to the gate line 2, a source electrode 10 connected to the data line 4 and a drain electrode 12 connected to the pixel electrode 14. The thin film transistor 6 also includes an active layer 48 overlapping the gate electrode 8 with a gate insulating film 46 therebetween. The active layer 48 has a channel between the source electrode 10 and the drain electrode 12. Other active layers 48 are formed in such a manner as to respectively overlap the data line 4, a lower data pad electrode 32 and an upper storage electrode 22. Further, the data line 4, the source electrode 10, the drain electrode 12, the lower data pad electrode 32 and an ohmic contact layer 50 for making an ohmic contact with the upper storage electrode 22 are provided on the active layers 48.

The pixel electrode 14 is formed in the pixel area and connected, via a first contact hole 13 passing through a protective film 52, to the drain electrode 12 of the thin film transistor 6. More particularly, the pixel electrode 14 includes a first horizontal portion 14A connected to the drain electrode 12 and formed in parallel to the adjacent gate line 2, a second horizontal portion 14B formed in such a manner as to overlap the common line 16 and finger portions 14C formed in parallel between the first and second horizontal portions 14A and 14B. The common electrode 18 is connected to the common line 16 and is formed in the pixel area. More particularly, the common electrode 18 has fingers formed in parallel to the finger portions 14C of the pixel electrode 14 in the pixel area.

A horizontal electric field can be formed between the pixel electrode 14, supplied with a pixel signal via the thin film transistor 6, and the common electrode 18, supplied with a reference voltage via the common line 16. More particularly, a horizontal electric field is formed between the finger portions 14C of the pixel electrode 14 and the fingers of the common electrode 18. Liquid crystal molecules are re-ar-

ranged or rotated in the horizontal direction between the thin film transistor array substrate and the color filter array substrate by such a horizontal electric field due to a dielectric anisotropy of the liquid crystal molecules. Transmittance of a light transmitting through the pixel area is differentiated depending upon a rotation extent of the liquid crystal molecules, thereby implementing a range of gray levels.

The storage capacitor **20** includes an upper storage electrode **22** overlapping the common line **16** with the gate insulating film **46**, the active layer **48** and the ohmic contact layer **50** therebetween. The pixel electrode **14** is connected, via a second contact hole **21** provided on the protective film **52**, to the upper storage electrode **22**. Such a storage capacitor **20** allows a pixel signal charged onto the pixel electrode **14** to be stably maintained until the next pixel signal is charged.

The gate line **2** is connected, via the gate pad **24**, to a gate driver (not shown). The gate pad **24** includes a lower gate pad electrode **26** extending from the gate line **2** and an upper gate pad electrode **28** connected, via a third contact hole **27** passing through the gate insulating film **46** and a protective film **52**, to the lower gate pad electrode **26**. The data line **4** is connected via the data pad **30** to a data driver (not shown). The data pad **30** includes a lower data pad electrode **32** extending from the data line **4** and an upper data pad electrode **34** connected, via a fourth contact hole **33** passing through the protective film **52**, to the lower data pad electrode **32**. The common line **16** is supplied, via a common pad **36**, with a reference voltage from a reference voltage source (not shown). The common pad **36** includes a lower common pad electrode **38** extending from the common line **16** and an upper common pad electrode **40** connected, via a fifth contact hole **39** passing through the gate insulating film **46** and the protective film **52**, to the lower common pad electrode **38**.

A method of fabricating a thin film transistor array substrate using a four-round mask process having will be described in detail with reference to FIG. 3A to FIG. 3D. As shown in FIG. 3A, a first conductive pattern group including the gate line **2**, the gate electrode **8**, the lower gate pad electrode **26**, the common line **16**, the common electrode **18** and the lower common pad electrode **38** is formed on the lower substrate **45** using a first mask process. More particularly, a first and second metal layer **42** and **44** are sequentially disposed on the lower substrate **45** by a deposition technique, such as sputtering, thereby providing a gate metal layer including two metal films. Next, the gate metal layer is patterned by a photolithography process and an etching process using the first mask, thereby providing the first conductive pattern group including the gate line **2**, the gate electrode **8**, the lower gate pad electrode **26**, the common line **16**, the common electrode **18** and the lower common pad electrode **38**. Herein, the first metal film **42** is formed from an Al-alloy metal etc., and the second metal film **44** is a metal, such as one of Chrome Cr and molybdenum Mo.

Referring to FIG. 3B, a gate insulating film **46** is coated onto the lower substrate **45** provided with the first conductive pattern group. A semiconductor pattern including the active layer **48** and the ohmic contact layer **50**, and a second conductive pattern group including the data line **4**, the source electrode **10**, the drain electrode **12**, the lower data pad electrode **32** and the upper storage electrode **22** are formed on the gate insulating film **46** using a second mask process. More particularly, the gate insulating film **46**, an amorphous silicon layer, an amorphous silicon layer doped with n+ impurities and a source/drain metal layer are sequentially formed on the lower substrate **45** provided with the first conductive pattern group by a deposition technique, such as PECVD or sputtering. Herein, the gate insulating film **46** is formed from an

inorganic insulating material, such as silicon oxide (SiO_x) or silicon nitride (SiN_x). The source/drain metal is formed of at least one of molybdenum (Mo), titanium (Ti), tantalum (Ta) and Mo-alloy.

Next, a photo-resist pattern is formed on the source/drain metal layer by a photolithography process using the second mask. In this case, the second mask employs a diffractive exposure mask having a diffractive exposure portion corresponding to the position of the channel of the thin film transistor. The portion of photo-resist pattern for the channel has a lower height than other portions, which is later ashed away and used to etch the source/drain electrodes above the channel region.

Next, the source/drain metal layer is patterned by a wet-etching process using the photo-resist pattern, thereby providing a second conductive pattern group including the data line **4**, the source electrode **10**, the drain electrode **12** integral with the source electrode **10**, and the upper storage electrode **22**. And then, the amorphous silicon layer doped with n+ impurities and the amorphous silicon layer are simultaneously patterned by a dry-etching process using the same photo-resist pattern, thereby providing the ohmic contact layer **50** and the active layer **48**. Subsequently, the portion of the photo-resist pattern having a relatively low height at the channel is removed by an ashing process. Then, a source/drain metal pattern and the ohmic contact layer **50** of the channel are formed by a dry-etching process. After the dry-etching process, the active layer **48** of the channel is exposed, so that the source electrode **10** and the drain electrode **12** are separated from each other. Next, the photo-resist pattern left on the second conductive pattern group is removed by a stripping process.

Referring to FIG. 3C, the protective film **52** having first to fifth contact holes **13**, **21**, **27**, **33** and **39** is formed on the gate insulating film **46** provided with the second conductive pattern group using a third mask process. More particularly, the protective film **52** is formed over the entire gate insulating film **46**, including the second conductive pattern group, by a deposition technique, such as PECVD. Next, the protective film **52** is patterned by a photolithography process and etching process using a third mask, thereby providing the first to fifth contact holes **13**, **21**, **27**, **33** and **39**. The first contact hole **13** passes through the protective film **52** to expose the drain electrode **12**. The second contact hole **21** passes through the protective film **52** to expose the upper storage electrode **22**. The third contact hole **27** passes through the protective film **52** and the gate insulating film **46** to expose the lower gate pad electrode **26**. The fourth contact hole **33** passes through the protective film **52** to expose the lower data pad electrode **32**. The fifth contact hole **39** passes through the protective film **52** and the gate insulating film **46** to expose the lower common pad electrode **38**. The source/drain metal is a metal having a high dry-etching ratio, such as a molybdenum Mo. The first, second and fourth contact holes **12**, **21** and **33** respectively pass through the drain electrode **12**, the upper storage electrode **22** and the lower data pad electrode **32** to expose side surfaces thereof. The protective film **52** is made of an inorganic insulating material identical to the gate insulating film **46**, or an organic insulating material, such as an acrylic organic compound having a small dielectric constant, BCB (benzocyclobutene) or PFCB (perfluorocyclobutane).

Referring to FIG. 3D, a third conductive pattern group, including the pixel electrode **14**, the upper gate pad electrode **28**, the upper data pad electrode **34** and the upper common pad electrode **40**, is formed on the protective film **52** using a fourth mask process. More particularly, a transparent conductive layer is coated on the protective film **52** by a deposition

technique, such as sputtering. Next, the transparent conductive layer is patterned by a photolithography process and an etching process using a fourth mask, thereby providing the third conductive pattern group including the pixel electrode 14, the upper gate pad electrode 28, the upper data pad electrode 34 and the upper common pad electrode 40. The pixel electrode 14 is electrically connected, via the first contact hole 13, to the drain electrode 12 and is electrically connected, via the second contact hole 21, to the upper storage electrode 22. The upper gate pad electrode 28 is electrically connected, via the third contact hole 37, to the lower gate pad electrode 26. The upper data pad electrode 34 is electrically connected, via the fourth contact hole 33, to the lower data pad electrode 32. The upper common pad electrode 40 is electrically connected, via the fifth contact hole 39, to the lower common pad electrode 38. The transparent conductive layer can be made of one of Indium Tin Oxide (ITO), Tin Oxide (TO) and Indium Zinc Oxide (IZO).

As described-above, a related art thin film transistor array substrate of an IPS mode liquid crystal display device and a fabricating method thereof uses a four-round mask process to reduce the number of mask processes as compared to a five-round mask process and to reduce the manufacturing cost. But, the four-round mask process has a drawback in that the capacitance capability with respect to the pixel electrode is small. Therefore, a horizontal electric field switching liquid crystal display device having increased capacitance and a fabricating process using four or less mask-rounds is needed to improve performance and/or further reduce the manufacturing cost.

SUMMARY OF THE INVENTION

Accordingly, the present invention is directed to a horizontal electric field switching liquid crystal display device and a fabricating method thereof that substantially obviate one or more of the problems due to limitations and disadvantages of the related art.

An object of the present invention to provide a horizontal electric field switching liquid crystal display device and a fabricating method thereof having a reduced number of mask rounds.

Another object of the present invention to provide a horizontal electric field switching liquid crystal display device having improved capacitance.

Additional features and advantages of the invention will be set forth in the description which follows, and in part will be apparent from the description, or may be learned by practice of the invention. The objectives and other advantages of the invention will be realized and attained by the structure particularly pointed out in the written description and claims hereof as well as the appended drawings.

To achieve these and other advantages and in accordance with the purpose of the present invention, as embodied and broadly described, a horizontal electric field switching liquid crystal display device includes a gate line, a common line parallel to the gate line and provided at an area adjacent to the gate line, a data line crossing the gate line with a gate insulating film therebetween to define a pixel area, a thin film transistor provided adjacent to a crossing of the gate line and the data line, a common electrode provided in the pixel area and connected to the common line, a pixel electrode connected to the thin film transistor and provided in such a manner to form a horizontal electric field along with the common electrode in the pixel area on the same plane as the common electrode, a storage capacitor electrode overlapping the common electrode to provide a storage capacitor, and a

contact electrode contacting the pixel electrode, the thin film transistor and the storage electrode at their side surfaces.

In another aspect, a method of fabricating a horizontal electric field switching liquid crystal display device includes forming a first conductive pattern group including a gate line, a gate electrode, a lower gate pad electrode, a common line, a common electrode, a lower common pad electrode and a pixel electrode on a substrate, forming a gate insulating film for covering the first conductive pattern group, forming a semiconductor pattern on the gate insulating layer and a second conductive pattern group on the semiconductor pattern, the second conductive pattern group including a source electrode, a lower data pad electrode, a drain electrode and an storage electrode extending from the drain electrode, forming a protective film on the gate insulating film and over the second conductive pattern group and the semiconductor pattern, forming a contact hole passing through the protective film and the gate insulating film, forming a third conductive pattern group including a contact electrode contacting the drain electrode and the pixel electrode at their side surfaces, and contacts to the gate pad electrode, an upper data pad electrode and an upper common pad electrode.

In another aspect, a horizontal electric field switching liquid crystal display device includes a gate line, a common line parallel to the gate line and provided at an area adjacent to the gate line, a data line crossing the gate line with a gate insulating film therebetween to define a pixel area, a thin film transistor provided adjacent to a crossing of the gate line and the data line, a common electrode in the pixel area and connected to the common line, a pixel electrode connected to the thin film transistor and provided in such a manner to form a horizontal electric field along with the common electrode in the pixel area on the same plane as the common electrode, a first storage capacitor including the common electrode, a second storage capacitor including the common line and an storage electrode; and a contact electrode contacting the pixel electrode, the thin film transistor and the storage electrode at their side surfaces.

It is to be understood that both the foregoing general description and the following detailed description are exemplary and explanatory and are intended to provide further explanation of the invention as claimed.

BRIEF DESCRIPTION OF THE DRAWINGS

The accompanying drawings, which are included to provide a further understanding of the invention and are incorporated in and constitute a part of this specification, illustrate embodiments of the invention and together with the description serve to explain the principles of the invention. In the drawings:

FIG. 1 is a plan view showing a portion of a thin film transistor array substrate of an IPS mode liquid crystal display device formed by a related art four-round mask process;

FIG. 2 is a cross-sectional view of the thin film transistor array substrate along the lines I-I' and II-II' in FIG. 1.

FIG. 3A to FIG. 3D are cross-sectional views showing stages for a method of fabricating the thin film transistor array substrate shown in FIG. 1;

FIG. 4 is a plan view showing a portion of a thin film transistor array substrate of a horizontal electric field switching liquid crystal display device according to a first embodiment of the present invention;

FIG. 5 are cross-sectional views of the thin film transistor array substrate taken along the III-III', IV-IV', V-V', VI-VI' lines in FIG. 4;

FIG. 6A and FIG. 6B are a plan view and a cross-sectional view for explaining a first mask process in a method of fabricating the thin film transistor array substrate according to the first embodiment of the present invention, respectively;

FIG. 7A and FIG. 7B are a plan view and a cross-sectional view for explaining a second mask process in a method of fabricating the thin film transistor array substrate according to the first embodiment of the present invention, respectively;

FIG. 8A and FIG. 8B are a plan view and a cross-sectional view for explaining a third mask process in a method of fabricating the thin film transistor array substrate according to the first embodiment of the present invention, respectively;

FIG. 9A and FIG. 9B are a plan view and a cross-sectional view for explaining a fourth mask process in a method of fabricating the thin film transistor array substrate according to the first embodiment of the present invention, respectively;

FIG. 10A and FIG. 10B are a plan view and a cross-sectional view for explaining a first mask process in a method of fabricating the thin film transistor array substrate according to a second embodiment of the present invention, respectively;

FIG. 11A and FIG. 11B are a plan view and a cross-sectional view for explaining a second mask process in a method of fabricating the thin film transistor array substrate according to the second embodiment of the present invention, respectively;

FIG. 12A and FIG. 12B are a plan view and a cross-sectional view of the thin film transistor array substrate of a horizontal electric field LCD after a third mask process in a method of fabricating the thin film transistor array substrate according to the second embodiment of the present invention, respectively; and

FIG. 13A to FIG. 13D are cross-sectional views for explaining a third mask process in a method of fabricating the thin film transistor array substrate according to the second embodiment of the present invention.

DETAILED DESCRIPTION OF THE PREFERRED EMBODIMENTS

Hereinafter, the preferred embodiments of the present invention will be described in detail with reference to FIG. 4 to FIG. 13D.

FIG. 4 is a plan view showing a portion of a thin film transistor array substrate of a horizontal electric field switching liquid crystal display device according to a first embodiment of the present invention, and FIG. 5 are cross-sectional views of the thin film transistor array substrate taken along lines III-III', IV-IV', V-V', VI-VI' and VII-VII' in FIG. 4. Referring to FIG. 4 and FIG. 5, a thin film transistor array substrate according to a first embodiment of the present invention includes a gate line 102 and a data line 104 provided in such a manner as to cross each other on a lower substrate 145 and having a gate insulating film 146 therebetween to define a pixel area, a thin film transistor provided adjacent to where the gate line 102 and data line 104 cross, a pixel electrode 114 and a common electrode 118 provided in such a manner as to form a horizontal electric field in the pixel area, and a common line 116 connected to a common electrode 118. The thin film transistor array substrate further includes a first and second upper storage electrodes 122 and 132 respectively overlapping portions of a horizontal common electrode line 116 and a common line 118, a gate pad 150 extending from a gate line 102, a data pad 160 extending from a data line 104, and a common pad 170 extending from a common line 116.

The gate line 102 is for supplying a gate signal and the data line 104 is for supplying a data signal. The data line 104 is "V" shaped and has an oblique line image that is bent so as to have vertical symmetry with a center of the pixel area. The common line 116 is for supplying a reference voltage to drive the liquid crystal display, and is formed to be parallel to the gate line 102 and spaced a pre-designated distance from the gate line 102.

The thin film transistor allows a pixel signal applied to the data line 104 to be charged onto the pixel electrode 114 while a scanning signal is applied to the gate line 102. The thin film transistor includes a gate electrode 108 connected to the gate line 102, a source electrode 110 connected to the data line 104 and a drain electrode 112 connected to the pixel electrode 114. The source electrode 110 is "U" shaped so as to partially enclose the drain electrode 112. The drain electrode 112 is connected to pixel electrodes 114 through a contact electrode 140. The thin film transistor also includes an active layer 148 overlapping the gate electrode 108 with a gate insulating film 146 therebetween. A portion of the active layer 148 includes a channel between the source electrode 110 and the drain electrode 112. Other portions of the active layer 148 are provided in such a manner as to be overlapped by the data line 104, the data pad 160, and a first and second upper storage electrode 122 and 132. The data line 104, the drain electrode 112, the data pad 160, and the ohmic contact layer 147 for making an ohmic contact with the first and second upper storage electrode 122 and 132 are provided on such portions of the active layer 148.

The common electrode 118 is connected to the common electrode line 116 and is formed in the pixel area. The common electrode 118 includes a horizontal portion 118A provided in parallel to the gate line 102 between the gate line 102 and the pixel area, and vertical portions 118B protruding from the horizontal portions 118A. The vertical portions 118B of the common electrode 118 are "V" shaped lines spaced apart from and corresponding to the data line 104. The pixel electrodes 114 have "V" shaped lines spaced apart from and corresponding to the data line 104. The pixel electrodes 114 are connected, via a first and second contact hole 126 and 128 passing through the gate insulating film 146 and the protective film 144, to the drain electrode 112 of the thin film transistor. The pixel electrodes 114 and the vertical portions 118B of the common electrode 118 are interleaved and form a slit pattern type in which the pixel area is divided into two areas having slits in different directions.

A horizontal electric field can be formed between the pixel electrode 114 supplied with a pixel signal, via the thin film transistor 106, and the common electrode 118 supplied with a reference voltage, via the common line 116. More particularly, a horizontal electric field is formed between the pixel electrode 114 and the common electrode 118. Liquid crystal molecules arranged in the horizontal direction between the thin film transistor array substrate and the color filter array substrate by such a horizontal electric field are rotated due to a dielectric anisotropy of the liquid crystal molecules. Transmittance of a light transmitted through the pixel area is differentiated depending upon the rotation extent of the liquid crystal molecules, thereby implementing an image.

A first storage capacitor 120 overlaps the common electrode line 116. The first storage electrode 122 integral with the drain electrode 114 and overlapping the ohmic contact layer 147, the active layer 148, and the gate insulating film 146 above the common electrode line 116. The first storage electrode 122 includes a first auxiliary storage electrodes 124 protruding from the first storage electrode 122 in such a

manner as to oppose the pixel electrode 114 so as to be connected to the pixel electrode 114.

The second storage capacitor 130 includes the second upper storage electrode 132 overlaps the horizontal portion 118A of the common electrode 118 with the ohmic contact layer 147, the active layer 148, and the gate insulating film 146 therebetween. Herein, a second upper storage electrode 132 includes a second auxiliary storage electrodes 134 protruding from the second upper storage electrode 132 in such a manner as to oppose the pixel electrode 114 so as to be connected, via third and fourth contact holes 136 and 138, to the pixel electrode 114. Such first and second storage capacitors 120 and 130 allow a pixel signal charged onto the pixel electrode 114 to be stably maintained until the next signal is charged. The contact electrodes 140a and 140b allows the first and second storage electrode 122 and 132, and the pixel electrodes 114 to be connected to each other at their side surfaces, which are at the edges of these layers. Thus, a contact electrode 140a contacts the side surface at the edge of the first storage electrode 122 and the side surface at the first edge of the pixel electrode 114, and another contact electrode 140b contacts the side surface at the edge of the second storage electrode 132 and the side surface at the second edge of the pixel electrode 114.

The gate line 102 supplies a gate signal to the gate electrode 108 of the thin film transistor. The gate line 102 is connected, via the gate pad 150, to a gate driver (not shown). The gate pad 150 includes a lower gate pad electrode 152 connected to the gate line 102 and an upper gate pad electrode 154 connected to the lower gate pad electrode 152 through a fifth contact hole 156 exposing the lower gate pad electrode 152.

The data line 104 supplies a pixel signal, via the drain electrode 112 of a thin film transistor, to the pixel electrode 114. Such data line 104 is connected, via a data pad 160, to a data driver (not shown). The data pad 160 includes a lower data pad electrode 162 connected to the data line 104, and an upper data pad electrode 164 connected to a lower data pad electrode 162 through a sixth contact hole 166 exposing the lower data pad electrode 162.

The common line 116 supplies a reference voltage to the common electrode 118 for driving the liquid crystal molecules. Such a common line 116 is connected, via a common pad 170, to a power supply (not shown). The common pad 170 includes a lower common pad electrode 172 connected to the common line 116, and an upper common pad electrode 174 connected to the lower common pad electrode 172 through a seventh contact hole 176 exposing the lower common pad electrode 172.

FIG. 6A to FIG. 9B are diagrams for explaining a method of fabricating the thin film transistor array substrate of horizontal electric field LCD according to the first embodiment of the present invention. FIG. 6A and FIG. 6B are a plan view and a cross-sectional view for explaining a first mask process in a method of fabricating the thin film transistor array substrate according to the first embodiment of the present invention, respectively. Referring to FIG. 6A and FIG. 6B, a first conductive pattern group including the gate line 102, the gate electrode 108, the lower gate pad electrode 152, the common line 116, the common electrode 118, the lower common pad electrode 172 and the pixel electrode 114 is formed on the lower substrate 145 using a first mask process. More particularly, a gate metal layer is formed on the lower substrate 145 by a deposition technique, such as the sputtering. The gate metal layer can be formed of one of an Al-family metal, copper (Cu) and Chrome (Cr). Next, the gate metal layer is patterned by a photolithography process and an etching process using the first mask, thereby providing the first conduc-

tive pattern group including the gate line 102, the gate electrode 108, the lower gate pad electrode 152, the common line 116, the common electrode 118, the lower common pad electrode 172 and the pixel electrode 114.

FIG. 7A and FIG. 7B are a plan view and a cross-section view for explaining a second mask process in a method of fabricating the thin film transistor array substrate according to the first embodiment of the present invention, respectively. Referring to FIG. 7A and FIG. 7B, the gate insulating film 146 is coated onto the lower substrate 145 having the first conductive pattern group. A semiconductor pattern including the active layer 148 and the ohmic contact layer 147, and a second conductive pattern group including the data line 104, the source electrode 110, the drain electrode 112, the lower data pad electrode 162 and the first and second upper storage electrodes 122 and 132 integral with the first and second auxiliary storage electrodes 124 and 134 are formed on the gate insulating film 146 using a second mask process. More particularly, the gate insulating film 146, an amorphous silicon layer, an amorphous silicon layer doped with n+ impurities and a source/drain metal layer are sequentially formed on the lower substrate 145 provided with the first conductive pattern group by a deposition techniques, such as PECVD or sputtering. The gate insulating film 146 is formed from an inorganic insulating material, such as silicon oxide (SiO_x) or silicon nitride (SiN_x). The source/drain metal is formed of one of molybdenum (Mo), titanium (Ti), tantalum (Ta) and Mo-alloy.

Next, a photo-resist pattern is formed on the source/drain metal layer by a photolithography process using the second mask. In this case, the second mask uses a diffractive exposure mask having a diffractive exposure portion corresponding to channel of the thin film transistor. The diffractive exposure portion of the photo-resist pattern has a lower height than other portions of the photo-resist pattern.

Next, the source/drain metal layer is patterned by a wet-etching process using the photo-resist pattern, thereby providing a second conductive pattern group including the data line 104, the drain electrode 112, the source electrode 110 having a "U" shaped electrode partially enclosing the drain electrode 112, the first storage electrode 122 integral to the drain electrode 110 and the second upper storage electrode 132.

Subsequently, the amorphous silicon layer doped with n+ impurities and the amorphous silicon layer are simultaneously patterned by a dry-etching process using the same photo-resist pattern, thereby providing the ohmic contact layer 147 and the active layer 148. Then, the diffractive exposure portion at the channel is removed by an ashing process. Next, the source/drain metal pattern and the ohmic contact layer 147 of the channel are etched by a dry-etching process. Accordingly, the active layer 148 of the channel is exposed so that the source electrode 110 and the drain electrode 112 are separated from each other. Next, the photo-resist pattern left on the second conductive pattern group is removed by a stripping process.

FIG. 8A and FIG. 8B are a plan view and a cross-sectional view for explaining a third mask process in a method of fabricating the thin film transistor array substrate according to the first embodiment of the present invention, respectively. Referring to FIG. 8A and FIG. 8B, the protective film 144 including first to seventh contact holes 126, 128, 136, 138, 156, 166 and 176 is formed on the gate insulating film 146 having the second conductive pattern group formed by the third mask process. More particularly, the protective film 144 is formed over the gate insulating film 146 on the second conductive pattern group by a deposition technique, such as

PECVD. Next, the protective film 144 is patterned by a photolithography process and an etching process using the third mask, thereby providing the first to seventh contact holes 126, 128, 136, 138, 156, 166 and 176.

The first and second contact holes 126 and 128 pass through the protective film 144 and the gate insulating film 146 to expose side surfaces of the pixel electrode 114 and the first storage electrode 122. The third and fourth contact holes 136 and 138 pass through the protective film 144 and the gate insulating film 146 to expose the side surfaces of the pixel electrode 114 and the second upper storage electrode 132. The fifth contact hole 156 passes through the protective film 144 and the gate insulating film 146 to expose the lower gate pad electrode 152. The sixth contact hole 166 passes through the protective film 144 to expose the lower data pad electrode 162. The seventh contact hole 176 passes through the protective film 144 and the gate insulating film 146 to expose the lower common pad electrode 172. The protective film 144 is made from an inorganic insulating material identical to the gate insulating film 146, or an organic insulating material, such as an acrylic organic compound having a small dielectric constant, benzocyclobutene (BCB) or perfluorocyclobutane (PFCB).

FIG. 9A and FIG. 9B are a plan view and a cross-sectional view for explaining a fourth mask process in a method of fabricating the thin film transistor array substrate according to the first embodiment of the present invention, respectively. Referring to FIG. 9A and FIG. 9B, a third conductive pattern group including the contact electrode 140, the upper gate pad electrode 154, the upper data pad electrode 164 and the upper common pad electrode 174 is formed on the protective film 144 by the fourth mask process. More particularly, a conductive layer is coated onto the protective film 144 by a deposition technique, such as sputtering.

Next, the conductive layer is patterned by a photolithography process and an etching process using the fourth mask, thereby providing the third conductive pattern group including the contact electrodes 140, the upper gate pad electrode 154, the upper data pad electrode 164 and the upper common pad electrode 174. One of the contact electrodes 140a connects the first storage electrode 122 (integral to the drain electrode 112) with the pixel electrode 114 at their side surfaces in the first and second contact holes 126 and 128. The other contact electrode 140b connects the second upper storage electrode 132 and the pixel electrode 114 at their side surfaces in the third and fourth contact holes 136 and 138. The upper gate pad electrode 154 is electrically connected, in the fifth contact hole 156, to the lower gate pad electrode 152. The upper data pad electrode 164 is electrically connected, in the sixth contact hole 166, to the lower data pad electrode 162. The upper common pad electrode 174 is electrically connected, in the seventh contact hole 176, to the lower common pad electrode 172. The conductive layer can be made of a material having a conductive property and crossing step coverage, such as one of Indium Tin Oxide (ITO), Tin Oxide (TO) and Indium Zinc Oxide (IZO), Titanium (Ti), AlNd, molybdenum Mo and titanium-molybdenum alloy.

FIG. 10A to FIG. 13B are diagrams for explaining a method of fabricating the thin film transistor array substrate of a horizontal electric field LCD according to a second embodiment of the present invention. The plan view and cross-sectional view of the thin film transistor array substrate of horizontal electric field LCD according to the second embodiment of the present invention are the same as the first embodiment. Therefore, an explanation as to the same elements will be omitted and only a method of fabricating will be described. But, the second embodiment of the present inven-

tion has a difference from the first embodiment of the present invention in that the contact electrode 140, the upper gate pad electrode 154, the upper data pad electrode 164 and the upper common pad electrode 174 are the same size as a contact hole or smaller than the size of the contact hole. This principle will be further described in the method of fabricating the thin film transistor array substrate of horizontal electric field LCD according to the second embodiment of the present invention.

FIG. 10A and FIG. 10B are a plan view and a cross-sectional view for explaining a first mask process in a method of fabricating the thin film transistor array substrate according to the second embodiment of the present invention, respectively. Referring to FIG. 10A and FIG. 10B, a first conductive pattern group including the gate line 102, the gate electrode 108, the lower gate pad electrode 152, the common line 116, the common electrode 118, the lower common pad electrode 172 and the pixel electrode 114 is formed on the lower substrate 145 using a first mask process. More particularly, a gate metal layer is formed on the lower substrate 145 by a deposition technique, such as sputtering. The gate metal layer can be formed of one of an Al-family metal, copper (Cu) and Chrome Cr. Next, the gate metal layer is patterned by a photolithography process and an etching process using the first mask, thereby providing the first conductive pattern group including the gate line 102, the gate electrode 108, the lower gate pad electrode 152, the common line 116, the common electrode 118, the lower common pad electrode 172 and the pixel electrode 114.

FIG. 11A and FIG. 11B are a plan view and a cross-sectional view for explaining a second mask process in a method of fabricating the thin film transistor array substrate according to the second embodiment of the present invention, respectively. Referring to FIG. 11A and FIG. 11B, the gate insulating film 146 is provided on the lower substrate 145 having the first conductive pattern group. A semiconductor pattern, including the active layer 148 and the ohmic contact layer 147, and a second conductive pattern group including the data line 104, the source electrode 110, the drain electrode 112, the lower data pad electrode 162 and the first and second upper storage electrode 122 and 132 (respectively integral to the first and second auxiliary storage electrodes 124 and 134) are formed on the gate insulating film 146 using the second mask process. More particularly, the gate insulating film 146, an amorphous silicon layer, an amorphous silicon layer doped with n+ impurities and a source/drain metal layer are sequentially formed on the lower substrate 145 having the first conductive pattern group by a deposition technique, such as PECVD or sputtering. The gate insulating film 146 is formed from an inorganic insulating material, such as silicon oxide (SiO_x) or silicon nitride (SiN_x). The source/drain metal is formed of one of molybdenum (Mo), titanium (Ti), tantalum (Ta) and Mo-alloy.

Next, a photo-resist pattern is formed on the source/drain metal layer by a photolithography process using the second mask. The second mask employs a diffractive exposure mask having a diffractive exposure portion corresponding to the channel of the thin film transistor. The diffractive exposure portion has a lower height than other portions of the diffractive exposure mask.

Next, the source/drain metal layer is patterned by a wet-etching process using the photo-resist pattern, thereby providing a second conductive pattern group including the data line 104, the drain electrode 112, the source electrode 110 having a "U" shape partially enclosing the drain electrode 112, the first storage electrode 122 integral to the drain electrode 110 and the second upper storage electrode 132. Then, the amorphous silicon layer doped with n+ impurities and the

amorphous silicon layer are simultaneously patterned by a dry-etching process using the same photo-resist pattern, thereby providing the ohmic contact layer **147** and the active layer **148**.

The diffractive exposure portion is removed by an ashing process, and then a source/drain metal pattern and the ohmic contact layer **147** of the channel are etched by the dry-etching process. Accordingly, the active layer **148** of the channel is exposed so that the source electrode **110** and the drain electrode **112** are separated each other. Next, the photo-resist pattern left on the second conductive pattern group is removed by a stripping process.

FIG. **12A** and FIG. **12B** are a plan view and a cross-sectional view of the thin film transistor array substrate of a horizontal electric field LCD after a third mask process in a method of fabricating the thin film transistor array substrate according to the second embodiment of the present invention, respectively. Referring to FIG. **12A** and FIG. **12B**, the gate insulating film and the protective film are patterned by the third mask process, thereby providing the first to seventh contact holes **126**, **128**, **136**, **138**, **156**, **166** and **176**, and the third conductive pattern group including the contact electrode **140**, the upper gate pad electrode **154**, the upper data pad electrode **164** and the upper common pad electrode **174**.

FIG. **13A** to FIG. **13D** are cross-sectional views for explaining a third mask process in a method of fabricating the thin film transistor array substrate according to the second embodiment of the present invention. Referring to FIG. **13A**, the protective film **144** is formed on the gate insulating film **146** above the second conductive pattern group by a deposition technique, such as PECVD. The protective film **144** is made from an inorganic insulating material identical to the gate insulating film **146**, or an organic insulating material, such as an acrylic organic compound having a small dielectric constant, benzocyclobutene (BCB) or perfluorocyclobutane (PFCB). A photo-resist pattern **180** is then formed on portions of the protective film **144** that should later exist by a photolithography process using the third mask process.

Next, the protective film **144** and the gate insulating film **146** are patterned by an etching process using the photo-resist pattern **180**, that is, a dry-etching process, thereby providing the first to seventh contact holes **126**, **128**, **136**, **138**, **156**, **166** and **176** shown in FIG. **12B**. More particularly, the first to the fourth contact holes **126**, **128**, **136** and **138** pass through the protective film **144** and the gate insulating film **146** to expose the side surfaces of the pixel electrode **114** and the storage electrodes **122** and **132**. The fifth contact hole **156** passes through the protective film **144** and the gate insulating film **146** to be exposed the lower gate pad electrode **152**. The sixth contact hole **166** passes through the protective film **144** to expose the lower data pad electrode **162**. The seventh contact hole **176** passes through the protective film **144** to expose the lower common pad electrode **172**. The ohmic contact layer **147** and the active layer **148** under the lower data pad electrode **162** and the lower common pad electrode **172** are etched, thereby allowing the active layer **148** left by the sixth and seventh contact holes **166** and **176** to be exposed, and the gate insulating film **146** may also be exposed.

Referring to FIG. **13B**, a conductive layer **182** is formed entirely over the thin film transistor **145** having the first photo-resist pattern **180** by a deposition technique, such as sputtering. The conductive layer **182** is made from a material having a conductive property and crossing step coverage such as one of Indium Tin Oxide (ITO), Tin Oxide (TO) and Indium Zinc Oxide (IZO), a Titanium (Ti), AlNd, molybdenum (Mo) and titanium-molybdenum alloy. A second photo-resist pattern **184** is formed within the first to seventh contact holes **126**,

128, **136**, **138**, **156**, **166** and **176**. In this case, the second photo-resist pattern **184** is formed by an O₂ plasma ashing processing after a photo-resist is formed over the entire conductive layer **182**.

Next, referring to FIG. **13C**, the conductive layer **182** is patterned by an etching process, such a wet etching, thereby leaving the conductive layer **182** positioned at an area that is overlapped with the second photo-resist pattern **184**. The patterned conductive layer **182** is the contact electrode **140**. Herein, the contact electrode **140** is formed in such a manner as to have a height above the protective film **144** because of the first photoresist film **180**.

Referring to FIG. **13D**, the first photo-resist pattern **180** for forming the contact holes and the second photo-resist pattern **184** for forming the contact electrode **140** are simultaneously stripped. In this case, the excess height of the contact electrode **140** above the protective film **144** is removed upon stripping of the second photo-resist pattern **184**, thereby making the height of the contact electrode **140** about the same or less than the height of the protective film **144** at the edge of the contact hole. Accordingly, the upper gate pad electrode **154**, the upper data pad electrode **164** and the upper common pad electrode **174** are similarly formed like the contact electrode **140** in such a manner as to have the same height as that of the protective film **144** or to have a lower height than that of the protective film **144** at the edge of the contact hole, thereby providing a third conductive pattern group.

As described-above, in a thin film transistor array substrate of horizontal electric field LCD device and a fabricating method thereof according to embodiments of the present invention, the pixel electrode **114** and the common electrode **118** are formed on the substrate **145** and are positioned in the same layer, and are side-contacted when the pixel electrode **114** and the drain electrode **112** are electrically connected. Also, the thin film transistor array substrate of horizontal electric field switching LCD and the fabricating method thereof according to embodiments of the present invention can be formed by a related art four-round mask process, and is formed by a three-round mask process, that is, a photo-resist pattern used upon forming of a contact hole leaves as it is, a photo-resist pattern is formed within a contact hole, thereby patterning a contact electrode. Accordingly, in the thin film transistor array substrate of horizontal electric field applying type according to the present invention, one mask process is eliminated, so that it becomes possible to reduce a process cost.

As described above, a horizontal electric field switching LCD device and a fabricating method thereof according to embodiments of the present invention can be formed by a four-round mask process, and a photo-resist pattern used upon forming of a contact hole leaves as it is, a photo-resist pattern is formed within a contact hole, thereby patterning a contact electrode, so that it becomes possible to eliminate one mask process. As a result, in the horizontal electric field switching LCD according to embodiments of the present invention, a thin film transistor array substrate is formed by a three-round mask process, the structure and the entire process of the thin film transistor array substrate can be simplified, so that it becomes possible to reduce a manufacturing cost as well as to improve productivity.

It will be apparent to those skilled in the art that various modifications and variations can be made in the horizontal electric field switching liquid crystal display device and a fabricating method thereof of the present invention without departing from the spirit or scope of the invention. Thus, it is intended that the present invention cover the modifications

and variations of this invention provided they come within the scope of the appended claims and their equivalents.

What is claimed is:

1. A horizontal electric field switching liquid crystal display device, comprising:
 - a gate line;
 - a common line parallel to the gate line and provided at an area adjacent to the gate line;
 - a data line crossing the gate line with a gate insulating film therebetween to define a pixel area;
 - a thin film transistor provided adjacent to a crossing of the gate line and the data line;
 - a common electrode provided in the pixel area and connected to the common line;
 - a plurality of pixel electrodes connected to the thin film transistor and provided in such a manner to form a horizontal electric field along with the common electrode in the pixel area on the same plane as the common electrode;
 - a first storage electrode extending from a drain electrode of the thin film transistor and overlapping the common line to provide a first storage capacitor;
 - a second storage electrode overlapping the common electrode to provide a second storage capacitor;
 - a protective layer disposed over the thin film transistor, the data line, and the gate insulating film with first and second contact holes defined through the protective layer and the gate insulating film such that the first contact hole exposes side surfaces of the first storage electrode and a first pixel electrode of the pixel electrodes and such that the second contact hole exposes side surfaces of the second storage electrode and the first pixel electrode;
 - a first contact electrode disposed in the first contact hole contacting the first pixel electrode first storage electrode at their side surfaces; and
 - a second contact electrode disposed in the second contact hole contacting the first pixel electrode and the second storage electrode at their side surfaces.
2. The horizontal electric field switching liquid crystal display device 1, wherein said thin film transistor includes:
 - a gate electrode connected to the gate line;
 - the drain electrode overlapping the common line and integral with the first storage electrode;
 - a source electrode connected to the data line and provided in a "U" shape partially enclosing the drain electrode; and
 - a semiconductor layer overlapping the gate electrode and having the gate insulating film therebetween, the semiconductor layer providing a channel between the source electrode and the drain electrode.

3. The horizontal electric field switching liquid crystal display device as claimed in claim 1, wherein said data line is in a "V" shape that is bent with vertical symmetry from a center of the pixel area.

4. The horizontal electric field switching liquid crystal display device as claimed in claim 3, wherein said common electrode includes a horizontal portion provided in parallel to the gate line, and a vertical portion interleaved between the pixel electrodes.

5. The horizontal electric field switching liquid crystal display device as claimed in claim 4, wherein the pixel electrodes and the vertical portions of the common electrode form a slit pattern type in which the pixel area is divided into two areas having slits in different directions.

6. The horizontal electric field switching liquid crystal display device as claimed in claim 1, wherein the first contact electrode includes one of indium tin oxide, tin oxide and indium zinc oxide, titanium, AlNd, molybdenum and titanium-molybdenum alloy.

7. The horizontal electric field switching liquid crystal display device as claimed in claim 1, wherein the first contact hole is disposed between the thin film transistor and the first pixel electrode, wherein the first contact electrode is positioned in the first contact hole and has a first height that is about the same or less than a second height of the protective film at the edge of the contact hole.

8. The horizontal electric field switching liquid crystal display device as claimed in claim 1, wherein the gate line is connected to a gate pad including a lower gate pad electrode and an upper gate pad electrode, and wherein a third contact hole is defined through the protective layer and the gate insulating film such that the third contact hole exposes the lower gate pad electrode, and the upper gate pad electrode is disposed in the third contact hole to contact the lower gate pad electrode;

wherein the data line is connected to a data pad including a lower data pad electrode and an upper data pad electrode, and wherein a fourth contact hole is defined through the protective layer such that the fourth contact hole exposes the lower data pad electrode, and the upper data pad electrode is disposed in the fourth contact hole to contact the lower data pad electrode; and

wherein the common line is connected to a common pad including a lower common pad electrode and an upper common pad electrode, and wherein a fifth contact hole is defined through the protective layer such that the fifth contact hole exposes the lower common pad electrode, and the upper common pad electrode is disposed in the fifth contact hole to contact the lower common pad electrode.

9. The horizontal electric field switching liquid crystal display device as claimed in claim 1, wherein the lower common pad electrode is disposed on a semiconductor pattern portion.

* * * * *

专利名称(译)	水平电场切换液晶显示装置		
公开(公告)号	US8199301	公开(公告)日	2012-06-12
申请号	US13/006391	申请日	2011-01-13
[标]申请(专利权)人(译)	OH JAE YOUNG HONG JIN SUNG		
申请(专利权)人(译)	OH JAE YOUNG HONG JIN SUNG		
当前申请(专利权)人(译)	LG DISPLAY CO. , LTD.		
[标]发明人	OH JAE YOUNG HONG SUNG JIN		
发明人	OH, JAE YOUNG HONG, SUNG JIN		
IPC分类号	G02F1/1343		
CPC分类号	G02F1/134363 G02F1/136213 G02F2001/136295 G02F2201/124		
优先权	1020050056560 2005-06-28 KR		
其他公开文献	US20110109827A1		
外部链接	Espacenet USPTO		

摘要(译)

一种水平电场切换液晶显示装置，包括栅极线，与栅极线平行且设置在与栅极线相邻的区域的公共线，与栅极线交叉的数据线，其间具有栅极绝缘膜以限定像素区域，邻近栅极线和数据线交叉设置的薄膜晶体管，设置在像素区域中并连接到公共线的公共电极，连接到薄膜晶体管并以这种方式设置的像素电极与公共电极在同一平面上的像素区域中与公共电极一起形成水平电场，与公共电极重叠以提供存储电容器的存储电容器电极，以及与像素电极接触的接触电极，薄膜晶体管和存储电极的侧面。

