



US 20140293203A1

(19) **United States**
(12) **Patent Application Publication**
KYE et al.

(10) **Pub. No.: US 2014/0293203 A1**
(43) **Pub. Date: Oct. 2, 2014**

(54) **LIQUID CRYSTAL DISPLAY DEVICE AND METHOD OF MANUFACTURING THE SAME**

Publication Classification

(71) Applicant: **SAMSUNG DISPLAY CO., LTD.**,
Yongin-City (KR)
(72) Inventors: **Myeong-Ha KYE**, Seoul (KR);
Jun-Hyup LEE, Seoul (KR); **Jae-Jin LYU**,
Yongin-si (KR); **Seung-Beom PARK**, Seoul (KR);
Jong-Ho SON, Seoul (KR); **Ji-Won SOHN**, Seoul (KR);
Hoon KIM, Ansan-si (KR); **Min-Goo SEOK**,
Yongin-si (KR); **Jun-Hee NA**, Asan-si (KR);
Min-Jae KIM, Suwon-si (KR); **Su-Han WOO**,
Asan-si (KR)

(51) **Int. Cl.**
G02F 1/1337 (2006.01)
(52) **U.S. Cl.**
CPC **G02F 1/133711** (2013.01); **G02F 1/133788**
(2013.01); **G02F 2001/133726** (2013.01)
USPC **349/123; 445/24**

(21) Appl. No.: **14/303,775**
(22) Filed: **Jun. 13, 2014**

Related U.S. Application Data

(63) Continuation of application No. 12/418,718, filed on Apr. 6, 2009, now Pat. No. 8,755,013.

Foreign Application Priority Data

Oct. 29, 2008 (KR) 10-2008-0106521

(57) **ABSTRACT**

A liquid crystal display device includes an array substrate, an opposite substrate and a liquid crystal display layer. The array substrate includes a pixel electrode and a lower reactive mesogen layer. The pixel electrode includes a plurality of slit portions disposed on a plurality of domains in different directions. The lower reactive mesogen layer is disposed on the pixel electrode to induce an inclined direction of liquid crystal molecules. The opposite substrate includes an upper substrate. An upper reactive mesogen layer is disposed on a common electrode of the opposite substrate. The liquid crystal layer includes liquid crystal molecules arranged to have a pretilt angle between a surface of the lower reactive mesogen layer and a surface of the upper reactive mesogen layer.

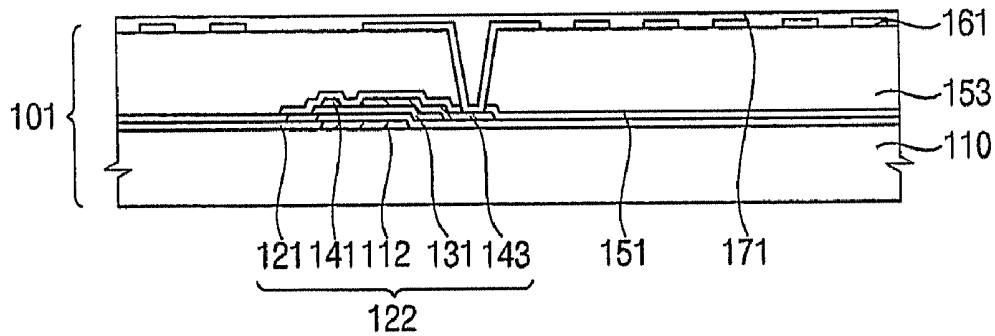

FIG. 1

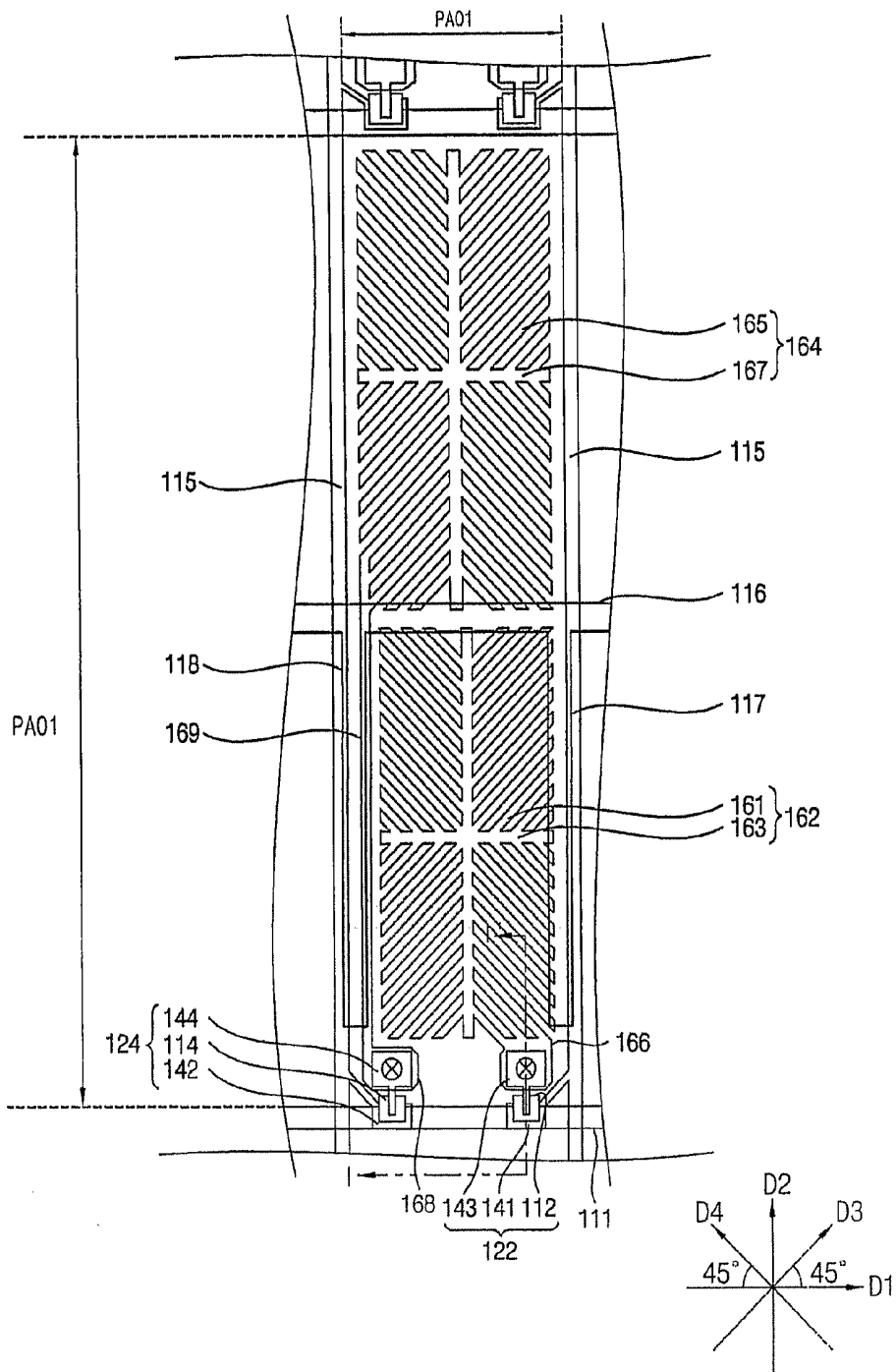

FIG. 2

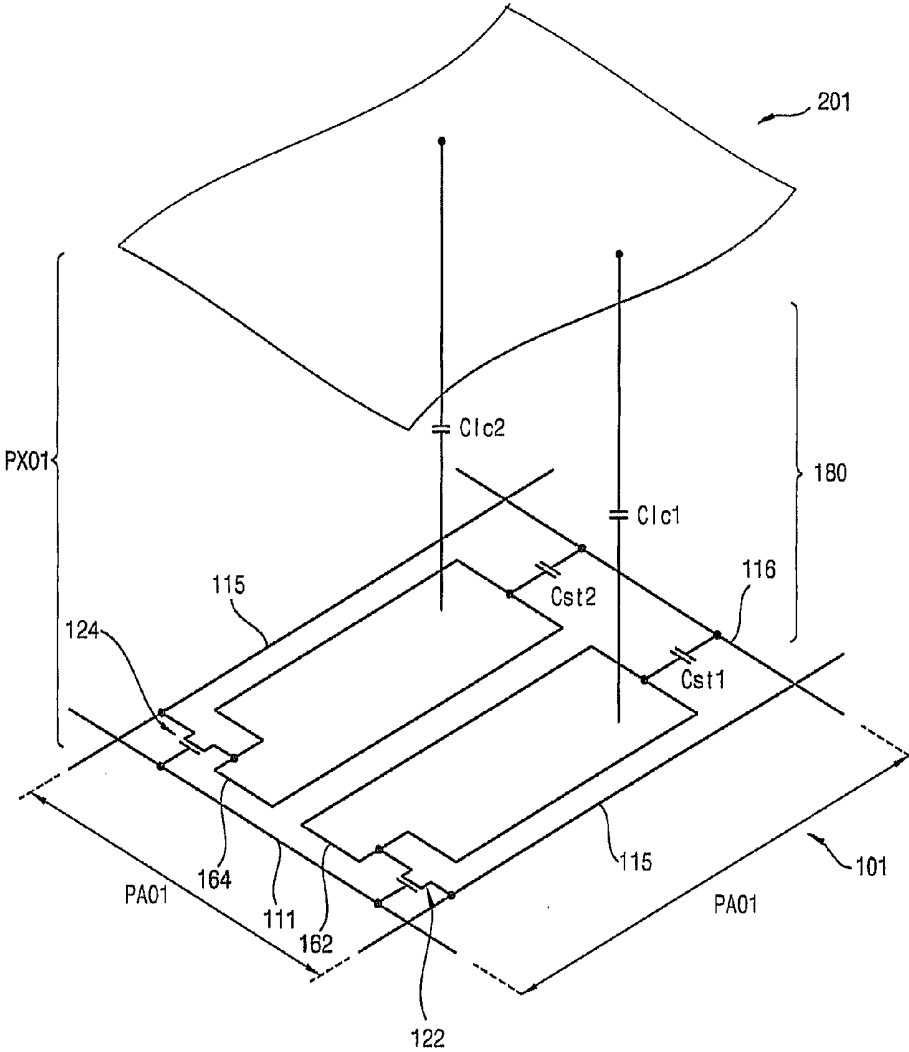

FIG. 3

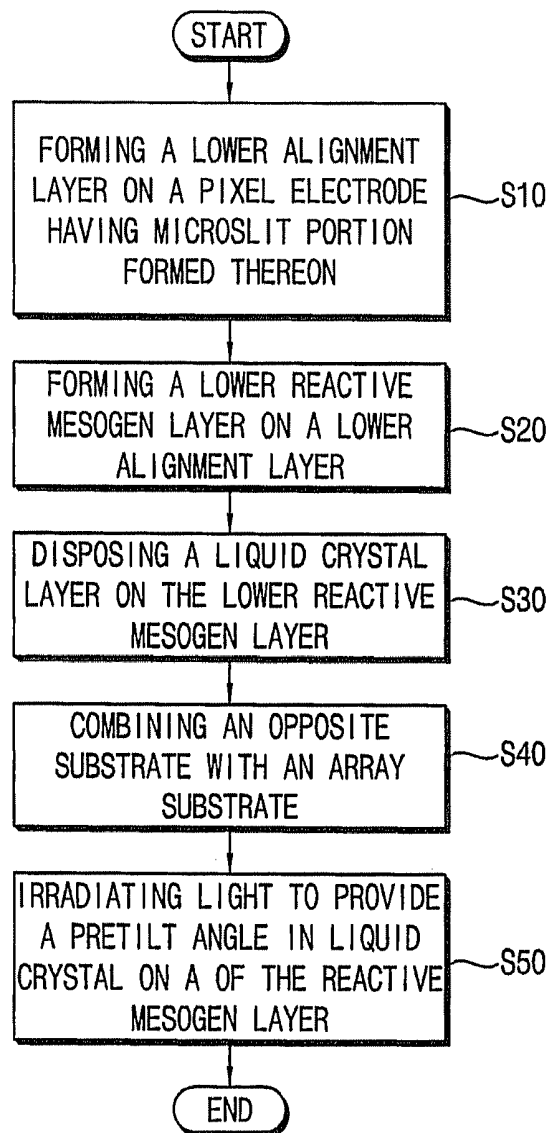

FIG. 4

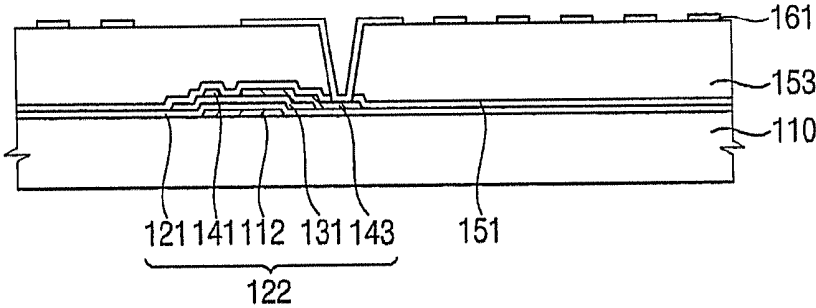

FIG. 5

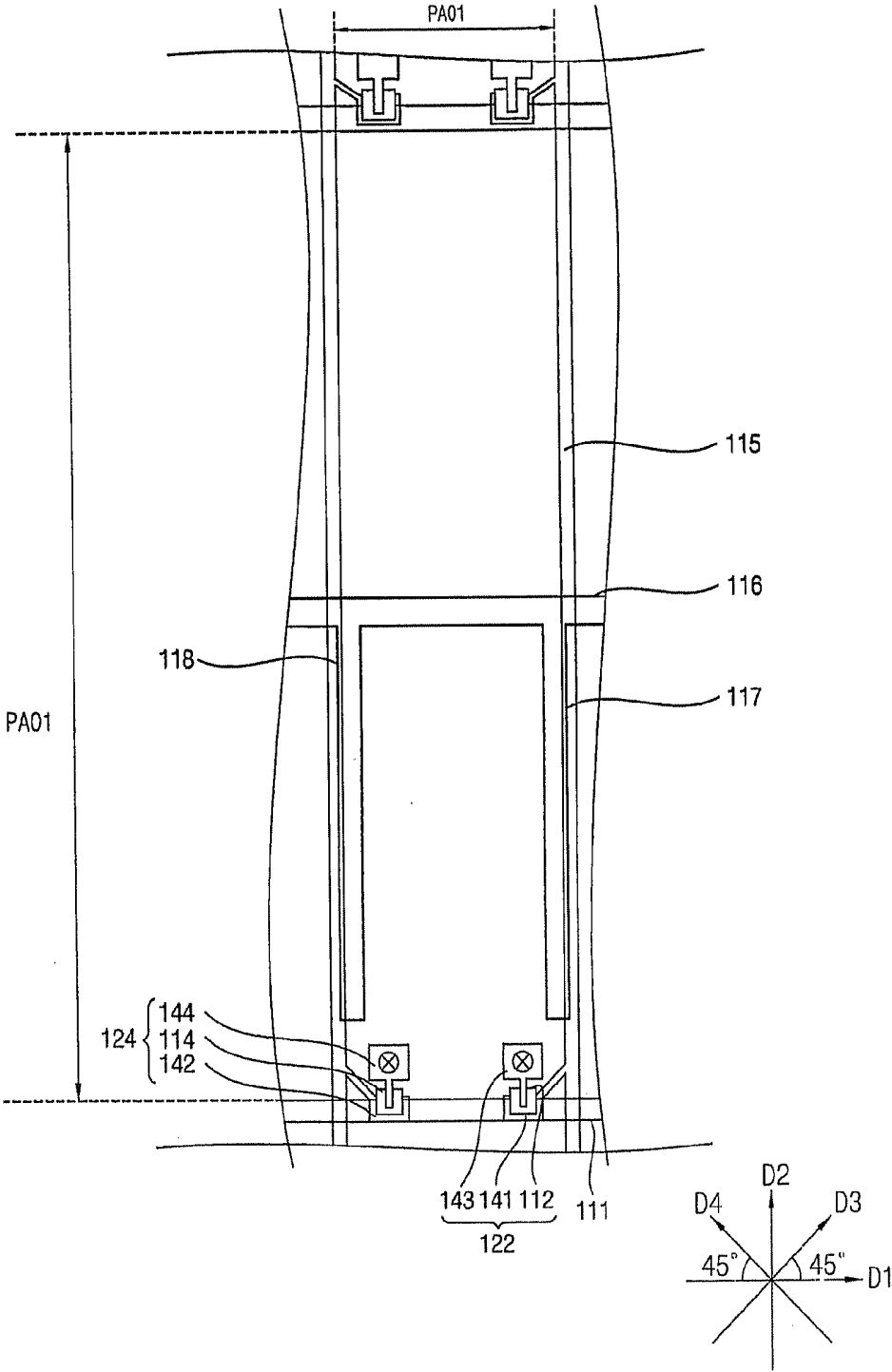

FIG. 6

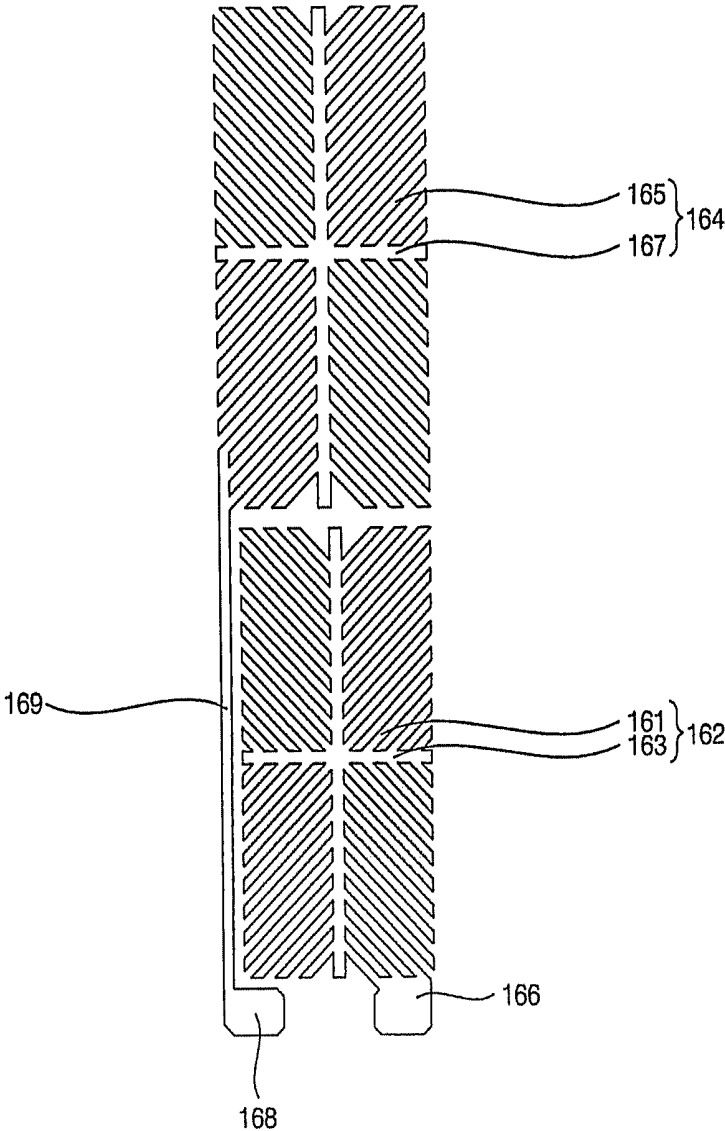

FIG. 7

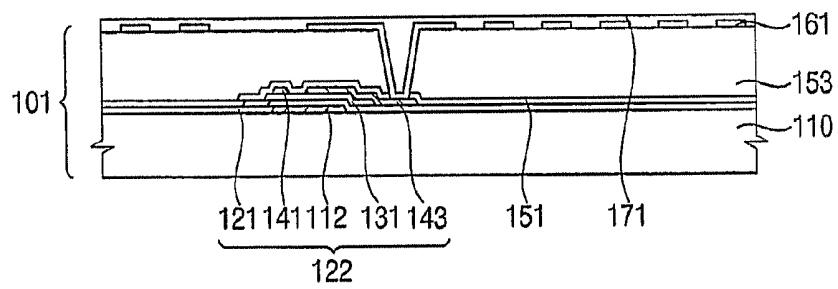

FIG. 8

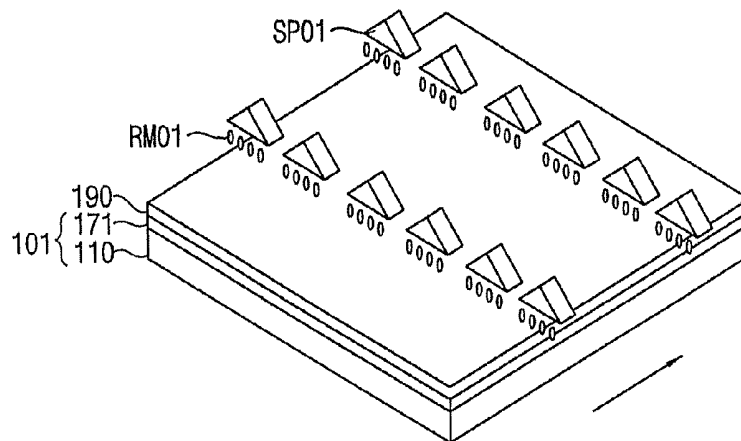

FIG. 9

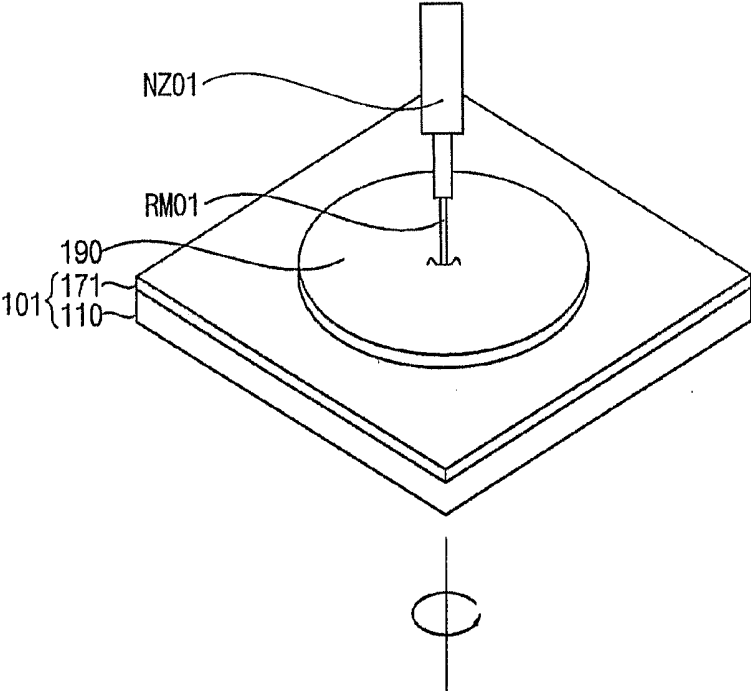

FIG. 10

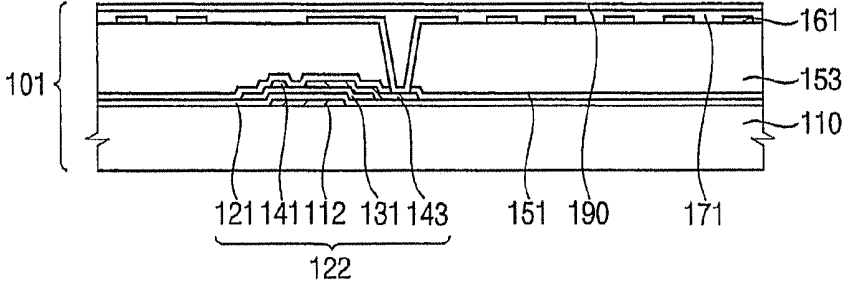

FIG. 11

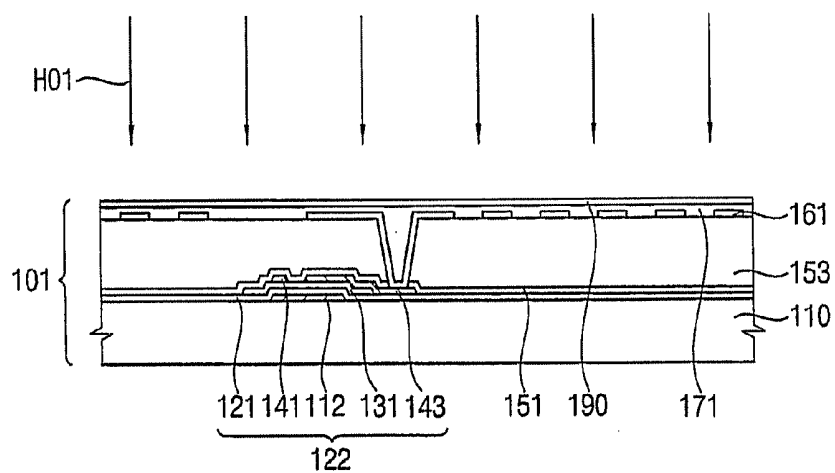

FIG. 12

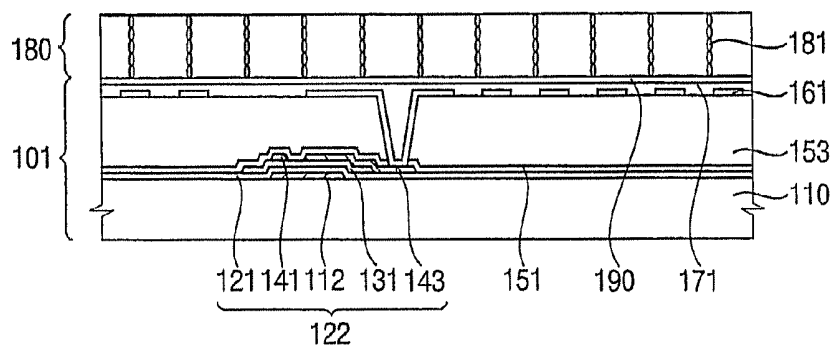

FIG. 13

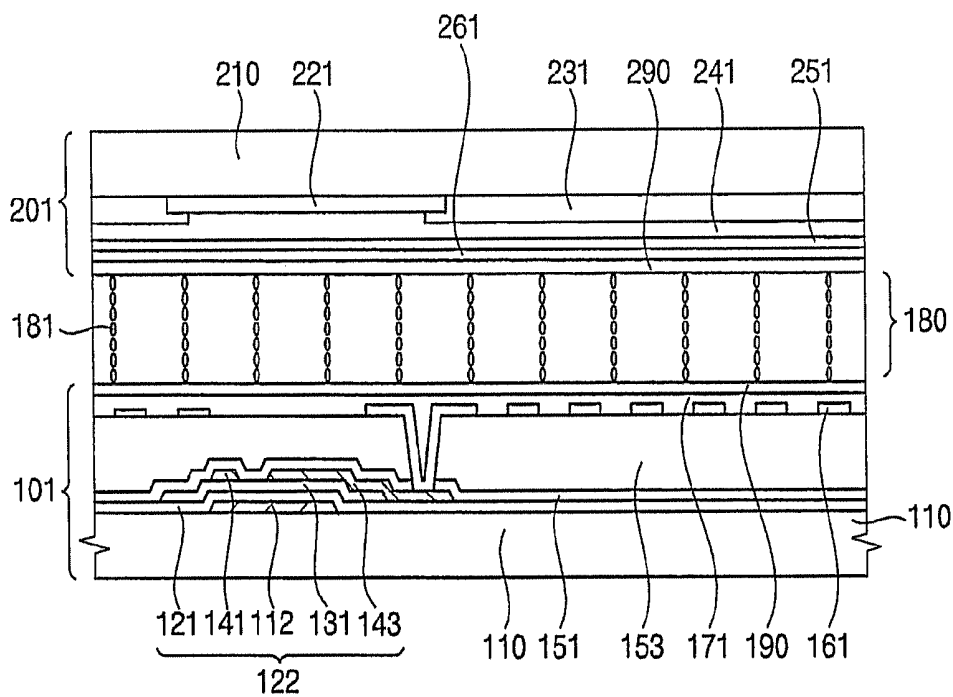

FIG. 14

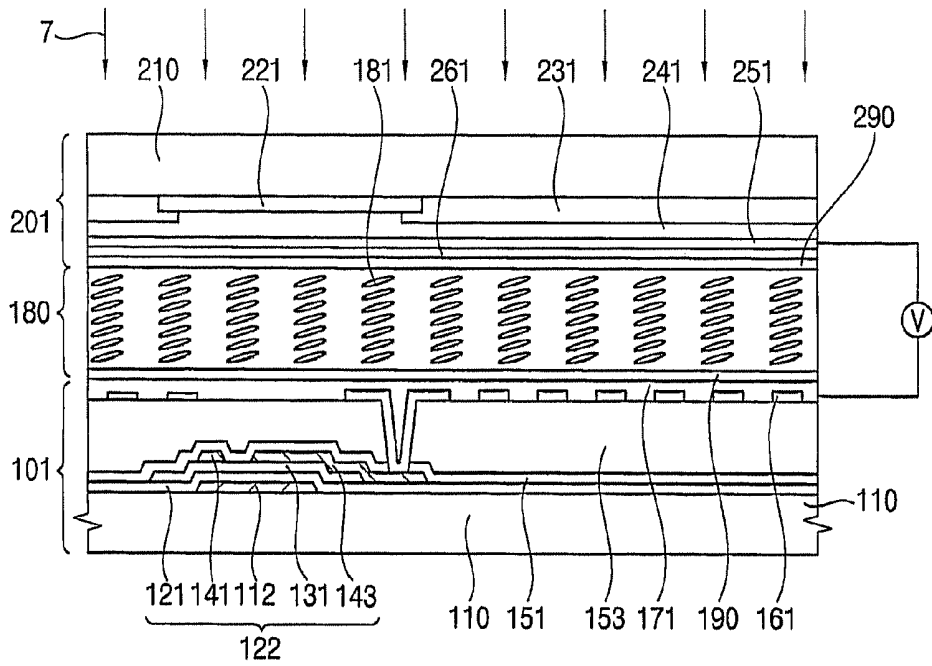

FIG. 15

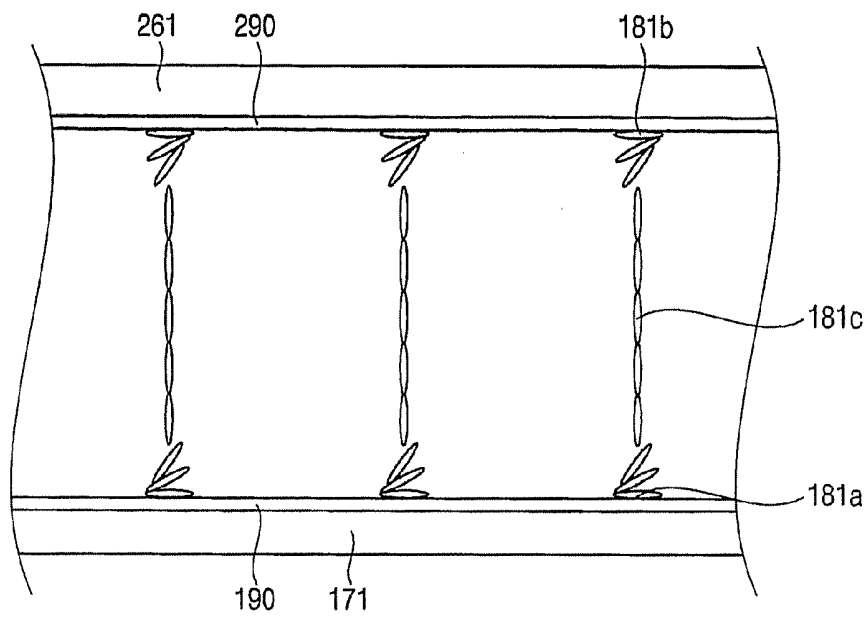

FIG. 16

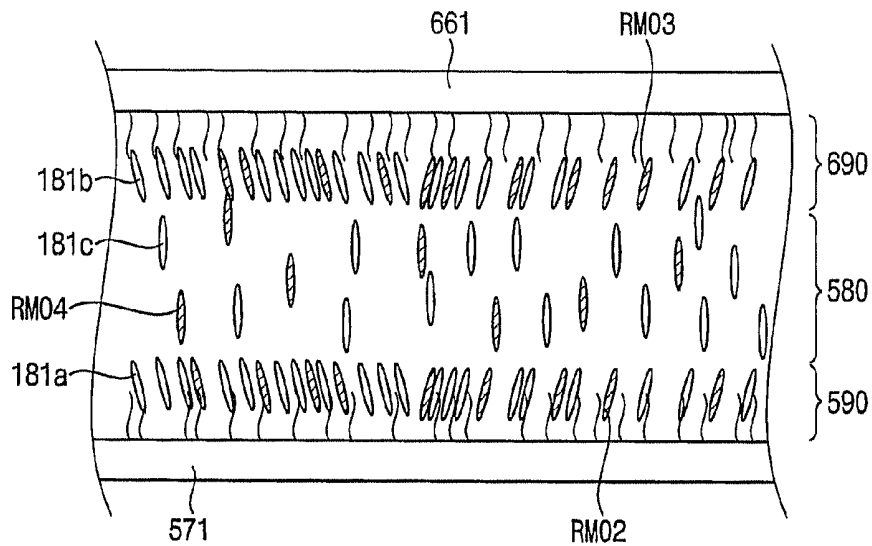

FIG. 17

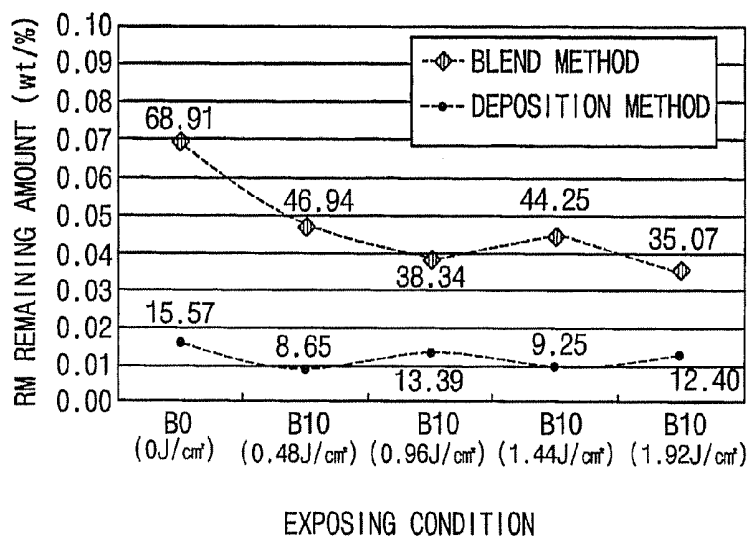

FIG. 18a

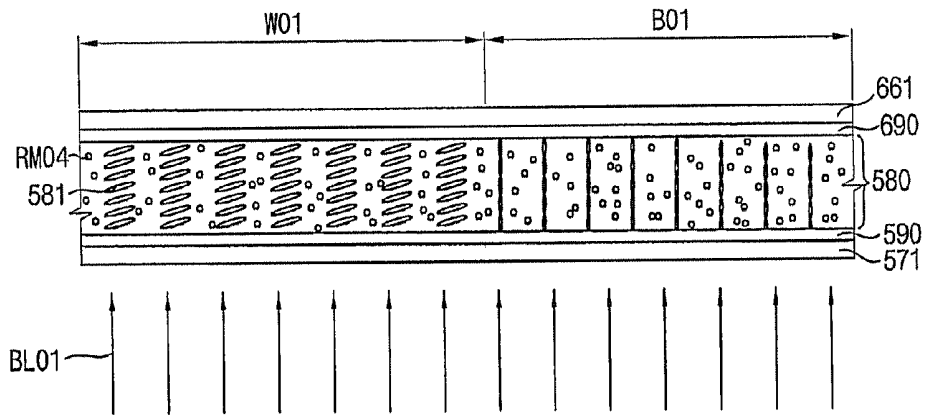

FIG. 18b

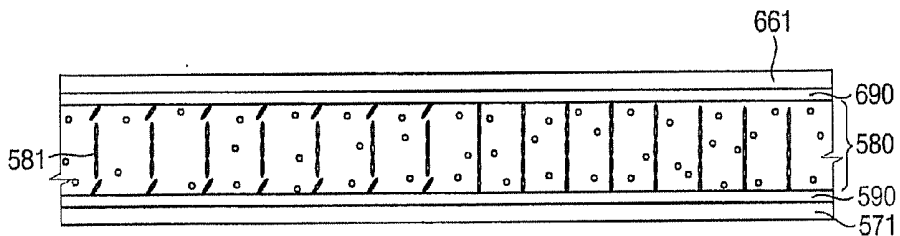

FIG 19A

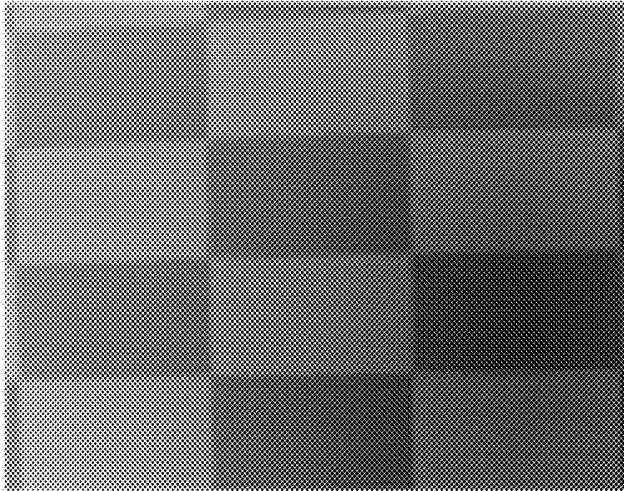

FIG 19B

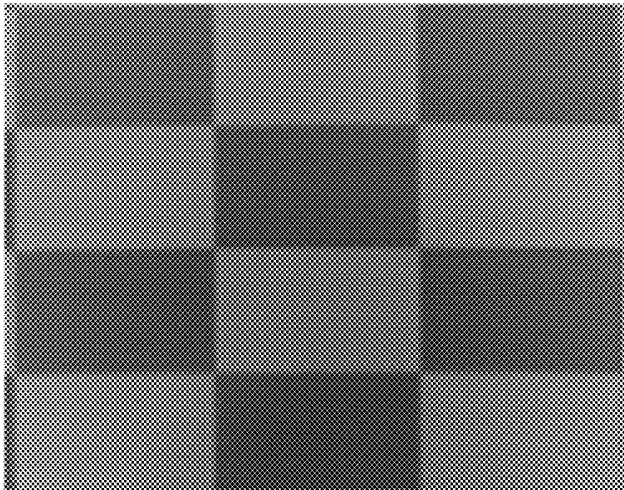

FIG 20A

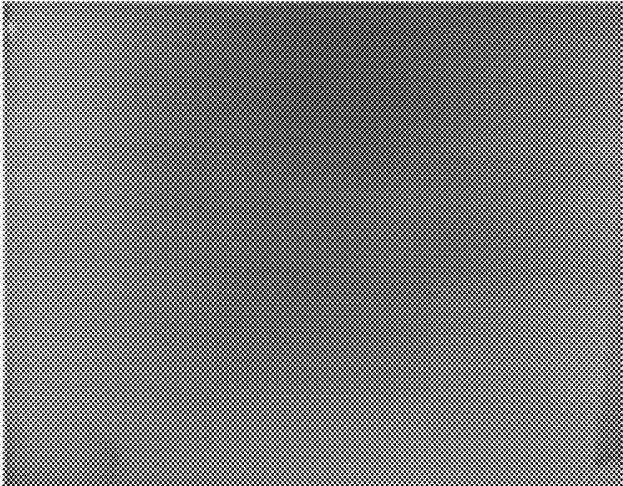
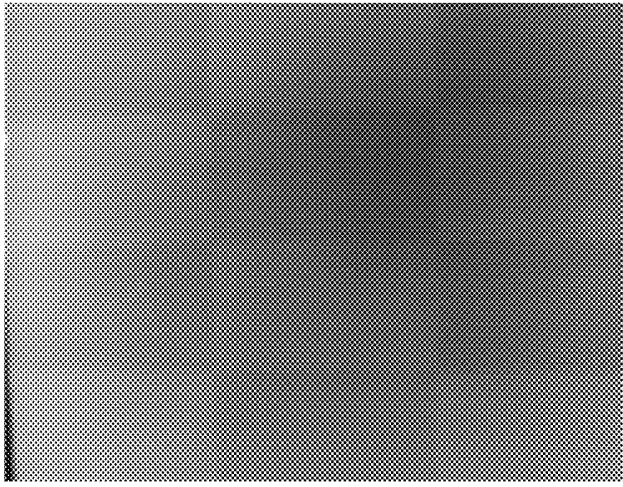

FIG 20B



LIQUID CRYSTAL DISPLAY DEVICE AND METHOD OF MANUFACTURING THE SAME

[0001] This application is a continuation application of U.S. application Ser. No. 12/418,718 filed Apr. 6, 2009, which claims priority to Korean Patent Application No. 10-2008-0106521 filed on Oct. 29, 2008, and all the benefits accruing therefrom under 35 U.S.C. § 119, the contents of which are herein incorporated by reference in their entirety.

BACKGROUND OF THE INVENTION

[0002] 1. Field of the Invention

[0003] Exemplary embodiments of the present invention relate to a liquid crystal display (“LCD”) device and a method of manufacturing the LCD device. More particularly, exemplary embodiments of the present invention relate to an LCD device capable of enhancing display quality such as a viewing angle and a response speed, and a method of manufacturing the LCD device.

[0004] 2. Description of the Related Art

[0005] In a liquid crystal display (“LCD”) device, a voltage is applied to an electric field generating electrode to provide the liquid crystal layer with an electric field, and an arrangement of liquid crystal molecules of the liquid crystal layer is controlled in response to the electric field, thereby displaying images.

[0006] In order to obtain a high contrast ratio and a wide viewing angle, a patterned vertical alignment (“PVA”) mode LCD device has been developed. In the PVA mode LCD device, an opening portion (hereinafter, a slit portion) of a slit shape is formed through the electric field generating electrode, and liquid crystals are vertically aligned to realize multiple domains.

[0007] For a medium or small sized mobile LCD device, in order to decrease the slit portion which decreases an aperture ratio, a micro slit mode LCD device or a super patterned vertical alignment (“SPVA”) mode LCD device has been developed. In the micro slit mode LCD device, a micro slit portion is only formed through a lower electrode of the electric field generating electrodes to provide a direction property to the liquid crystal, and an upper electrode is formed as a flat continuous plate in which an opening portion is not formed.

[0008] In a vertical alignment (“VA”) mode, such as the PVA mode and the micro slit mode, a rubbing is not directly performed on an alignment layer, however, a light alignment method may be employed which aligns liquid crystal by inducing anisotropy to an alignment layer through light irradiating.

[0009] Polarized UV lights are irradiated to a light bridge high-molecular copolymer including a mesogenic group of a liquid crystal property, also called a reactive mesogen, to induce anisotropy, and then anisotropy of the alignment layer is enhanced to align liquid crystal by heat processing on the light bridge high-molecular copolymer.

BRIEF SUMMARY OF THE INVENTION

[0010] Since a reactive mesogen may be employed to induce anisotropy to an alignment layer through light irradiating, there may be technical difficulties in manufacturing an LCD device when the reactive mesogen is used. For example, the reactive mesogen is not cured at a surface of the alignment layer, and the reactive mesogen remains within an inner area of the liquid crystal layer. The remaining reactive mesogen may be additionally cured by a backlight of the LCD device,

however, the cured amounts of the reactive mesogen in accordance with varying areas are different from each other so that a pretilt angle of liquid crystal may be non-uniform between the varying areas. As a result, an afterimage may be undesirably viewed on a display screen.

[0011] Exemplary embodiments of the present invention provide an LCD device having improved display quality, such as a viewing angle and a response speed.

[0012] Exemplary embodiments of the present invention provide a method of manufacturing the above-mentioned LCD device.

[0013] An exemplary embodiment of an LCD device includes an array substrate, an opposite substrate and a liquid crystal layer. The array substrate includes a lower substrate, a pixel electrode and a lower reactive mesogen layer. The lower substrate includes a switching part disposed thereon. The pixel electrode is disposed on a unit pixel area of the lower substrate to contact with the switching part. The pixel electrode includes a plurality of slit portions disposed on a plurality of domains and extended in different directions. The lower reactive mesogen layer is disposed on the pixel electrode to induce a slant direction of liquid crystal molecules. The opposite substrate includes an upper substrate opposite to the lower substrate. A common electrode is disposed on the upper substrate and faces the pixel electrode, and an upper reactive mesogen layer is disposed on the common electrode. The liquid crystal layer includes liquid crystal molecules affected to have a pretilt angle and disposed between a surface of the lower reactive mesogen layer and a surface of the upper reactive mesogen layer.

[0014] In an exemplary embodiment of the present invention, the array substrate may further include a lower alignment layer disposed between the pixel electrode and the lower reactive mesogen layer. The opposite substrate may further include an upper alignment layer disposed between the common electrode and the upper reactive mesogen layer. A weight of uncured reactive mesogen material diffused from the lower and upper reactive mesogen layers to the liquid crystal layer, is no more than about 20 weight percent (wt %) with respect to a weight of the lower and upper reactive mesogen layers. The LCD device may further include a diffusion stop layer disposed on surfaces of the lower reactive mesogen layer and the upper reactive mesogen layer to block the reactive mesogen layer from being diffused to the liquid crystal layer.

[0015] In an exemplary embodiment of the present invention, the pixel electrode may include a first pixel electrode and a second pixel electrode which are disposed on the unit pixel area and respectively receive different pixel voltages. The slit portions may be disposed on a plurality of domains defined on the first and second pixels, respectively, in the different directions. The common electrode corresponding to the first and second pixel electrodes may have a substantially flat plate shape in which an opening is not disposed. The lower alignment layer and the upper alignment layer may be aligned to be vertically arranged to a long axis of the liquid crystal molecules when an electric field applied to the liquid crystal layer is turned off. Alternatively, the lower alignment layer and the upper alignment layer may be aligned to arrange a long axis of the liquid crystal molecules in an extending direction of the slit portion at each of the domains when an electric field applied to the liquid crystal layer is turned off.

[0016] An exemplary embodiment provides a method of manufacturing an LCD device. In the method, a lower alignment layer is disposed on an array substrate including a pixel

electrode including a plurality of slit portions inducing an alignment direction of liquid crystal molecules. A lower reactive mesogen layer is disposed on the lower alignment layer. A liquid crystal layer is disposed on the lower reactive mesogen layer. An opposite substrate is coupled with the array substrate. Light is irradiated at a condition in which an electric field is applied to the liquid crystal layer through the pixel electrode to provide a pretilt angle to the liquid crystal molecules at a surface of the lower reactive mesogen layer.

[0017] In an exemplary embodiment of the present invention, in the method, an upper alignment layer may be disposed on a common electrode of the opposite substrate before the coupling with the array substrate, and an upper reactive mesogen layer may be disposed on the upper alignment layer. The common electrode corresponding to the pixel electrode may have a substantially flat plate shape in which an opening is not disposed.

[0018] In an exemplary embodiment of the present invention, the lower reactive mesogen layer and the upper reactive mesogen layer may be formed by coating a reactive mesogen blend, including a reactive mesogen, on the lower alignment layer and the upper alignment layer, respectively, through a spray method or a coating method. A weight of uncured reactive mesogen material, which is diffused from the lower and upper reactive mesogen layers to the liquid crystal layer, may be no more than about 20 weight percent (wt %) with respect to an initial weight of the lower and upper reactive mesogen layer. Alternatively, a weight of uncured reactive mesogen material, which is diffused from the lower and upper reactive mesogen layers to the liquid crystal layer, may be no more than about 1.0 weight percent (wt %) with respect to an initial weight of the lower and upper reactive mesogen layer. A diffusion stop layer may be further formed, which reduced or effectively prevents the reactive mesogen layer from being diffused to the liquid crystal layer, on surfaces of the lower reactive mesogen layer and the upper reactive mesogen layer. The diffusion stop layer may be formed through a heat processing or a light reactive processing of surfaces of the lower reactive mesogen layer and the upper reactive mesogen layer before the liquid crystal layer is disposed.

[0019] In an exemplary embodiment of the present invention, the lower alignment layer and upper alignment layer may be formed by coating a blend including at least one of photo-reactive polymer of a cinematic series and a polymer of a polyimide series on the pixel electrode and the common electrode. The pixel electrodes may be disposed on a unit pixel area of the array substrate, and the slit portions may be disposed in the different directions on a plurality of domains defined on each of the pixel electrodes. The lower alignment layer and the upper alignment layer may be aligned so that a long axis of the liquid crystal molecules is vertically aligned. Alternatively, the lower alignment layer and the upper alignment layer may be aligned so that the long axis of the liquid crystal molecules is arranged in an extending direction of the slit portion at each of the domains.

[0020] In exemplary embodiments of the LCD device and the method of manufacturing the LCD device, an aperture ratio and a response speed are enhanced, and a generation of an undesired afterimage is decreased, so that display quality may be advantageously enhanced.

BRIEF DESCRIPTION OF THE DRAWINGS

[0021] The above and other features and advantages of the present invention will become more apparent by describing in

detailed exemplary embodiments thereof with reference to the accompanying drawings, in which:

[0022] FIG. 1 is a plan view illustrating an exemplary embodiment of an array substrate employed in a liquid crystal display (LCD) device;

[0023] FIG. 2 is an equivalent circuit diagram illustrating an exemplary embodiment of one pixel in the LCD including the array substrate illustrated in FIG. 1;

[0024] FIG. 3 is a flowchart illustrating an exemplary embodiment of a method of manufacturing an LCD device;

[0025] FIG. 4 is a cross-sectional view taken along line I-I' of the array substrate of FIG. 1;

[0026] FIG. 5 is a plan view illustrating an exemplary embodiment of the array substrate excluding a pixel electrode of FIG. 1;

[0027] FIG. 6 is a plan view illustrating an exemplary embodiment of a pixel electrode of the array substrate as illustrated in FIG. 1;

[0028] FIG. 7 is a cross-sectional view illustrating an exemplary embodiment of a process for manufacturing a lower alignment layer on an array substrate of FIG. 4;

[0029] FIG. 8 is a process diagram illustrating an exemplary embodiment of a process for manufacturing a lower reactive mesogen ("RM") layer on the lower alignment layer through a spray method;

[0030] FIG. 9 is a process diagram illustrating an exemplary embodiment of a process for manufacturing a lower RM layer on the lower alignment layer through a coating method;

[0031] FIG. 10 is a cross-sectional view illustrating an exemplary embodiment of a process for manufacturing a lower RM layer on a lower alignment layer;

[0032] FIG. 11 is a cross-sectional view illustrating an exemplary embodiment of a process for manufacturing a diffusion stop layer on a surface of a lower RM layer;

[0033] FIG. 12 is a cross-sectional view illustrating an exemplary embodiment of a process for disposing a liquid crystal layer on a lower RM layer;

[0034] FIG. 13 is a cross-sectional view illustrating an exemplary embodiment of a process for combining an array substrate including a liquid crystal layer disposed thereon and an opposite substrate;

[0035] FIGS. 14 and 15 are cross-sectional views illustrating an exemplary embodiment of a process for allowing a pretilt angle of liquid crystal molecules;

[0036] FIG. 16 is a cross-sectional view illustrating an exemplary embodiment of a generation of the remaining RM layer in the LCD device, in which liquid crystals and RM material are blended to form a liquid crystal layer;

[0037] FIG. 17 is a graph illustrating a relationship between amounts of the RM remaining in the liquid crystal layer of the LCD device as described in FIG. 16 and an exposing time, and amounts of the RM remaining at the liquid crystal layer of the LCD device as described in FIGS. 1 to 15 and an exposing time;

[0038] FIGS. 18A and 18B are cross-sectional views illustrating exemplary embodiments of a pretilt angle of liquid crystal molecules at a black driving area and a white driving area of an LCD device manufactured by the blending method;

[0039] FIGS. 19A and 19B are photographs illustrating exemplary embodiments of a display screen of the LCD device manufactured by the blending method as described in FIG. 16; and

[0040] FIGS. 20A and 20B are photographs illustrating a display screen of the LCD device as described in FIGS. 1 to 15.

DETAILED DESCRIPTION OF THE INVENTION

[0041] The present invention is described more fully hereinafter with reference to the accompanying drawings, in which exemplary embodiments of the present invention are shown. The present invention may, however, be embodied in many different forms and should not be construed as limited to the exemplary embodiments set forth herein. Rather, these exemplary embodiments are provided so that this disclosure will be thorough and complete, and will fully convey the scope of the present invention to those skilled in the art. In the drawings, the sizes and relative sizes of layers and regions may be exaggerated for clarity.

[0042] It will be understood that when an element or layer is referred to as being “on,” “connected to” or “coupled to” another element or layer, it can be directly on, connected or coupled to the other element or layer or intervening elements or layers may be present. In contrast, when an element is referred to as being “directly on,” “directly connected to” or “directly coupled to” another element or layer, there are no intervening elements or layers present. Like numerals refer to like elements throughout. As used herein, the term “and/or” includes any and all combinations of one or more of the associated listed items.

[0043] It will be understood that, although the terms first, second, third etc. may be used herein to describe various elements, components, regions, layers and/or sections, these elements, components, regions, layers and/or sections should not be limited by these terms. These terms are only used to distinguish one element, component, region, layer or section from another region, layer or section. Thus, a first element, component, region, layer or section discussed below could be termed a second element, component, region, layer or section without departing from the teachings of the present invention.

[0044] Spatially relative terms, such as “lower,” “upper” and the like, may be used herein for ease of description to describe one element or feature’s relationship to another element(s) or feature(s) as illustrated in the figures. It will be understood that the spatially relative terms are intended to encompass different orientations of the device in use or operation in addition to the orientation depicted in the figures. For example, if the device in the figures is turned over, elements described as “lower” relative to other elements or features would then be oriented “upper” relative to the other elements or features. Thus, the exemplary term “lower” can encompass both an orientation of above and below. The device may be otherwise oriented (rotated 90 degrees or at other orientations) and the spatially relative descriptors used herein interpreted accordingly.

[0045] The terminology used herein is for the purpose of describing particular exemplary embodiments only and is not intended to be limiting of the present invention. As used herein, the singular forms “a,” “an” and “the” are intended to include the plural forms as well, unless the context clearly indicates otherwise. It will be further understood that the terms “comprises” and/or “comprising,” when used in this specification, specify the presence of stated features, integers, steps, operations, elements, and/or components, but do not preclude the presence or addition of one or more other features, integers, steps, operations, elements, components, and/or groups thereof.

[0046] Exemplary embodiments of the invention are described herein with reference to cross-sectional illustrations that are schematic illustrations of idealized exemplary embodiments (and intermediate structures) of the present invention. As such, variations from the shapes of the illustrations as a result, for example, of manufacturing techniques and/or tolerances, are to be expected. Thus, exemplary embodiments of the present invention should not be construed as limited to the particular shapes of regions illustrated herein but are to include deviations in shapes that result, for example, from manufacturing. For example, an implanted region illustrated as a rectangle will, typically, have rounded or curved features and/or a gradient of implant concentration at its edges rather than a binary change from implanted to non-implanted region. Likewise, a buried region formed by implantation may result in some implantation in the region between the buried region and the surface through which the implantation takes place. Thus, the regions illustrated in the figures are schematic in nature and their shapes are not intended to illustrate the actual shape of a region of a device and are not intended to limit the scope of the present invention.

[0047] Unless otherwise defined, all terms (including technical and scientific terms) used herein have the same meaning as commonly understood by one of ordinary skill in the art to which this invention belongs. It will be further understood that terms, such as those defined in commonly used dictionaries, should be interpreted as having a meaning that is consistent with their meaning in the context of the relevant art and will not be interpreted in an idealized or overly formal sense unless expressly so defined herein.

[0048] All methods described herein can be performed in a suitable order unless otherwise indicated herein or otherwise clearly contradicted by context. The use of any and all examples, or exemplary language (e.g., “such as”), is intended merely to better illustrate the invention and does not pose a limitation on the scope of the invention unless otherwise claimed. No language in the specification should be construed as indicating any non-claimed element as essential to the practice of the invention as used herein. Hereinafter, the present invention will be explained in detail with reference to the accompanying drawings.

[0049] FIG. 1 is a plan view illustrating an exemplary embodiment of an array substrate 101 employed in a liquid crystal display (“LCD”) device. FIG. 2 is an equivalent circuit diagram illustrating an exemplary embodiment of one pixel PX01 in the LCD including the array substrate 101 illustrated in FIG. 1.

[0050] Referring to FIGS. 1 and 2, an LCD device includes the array substrate 101, an opposite substrate 201 and a liquid crystal layer 180 interposed between the array substrate 101 and the opposite substrate 201. Various technologies for enhancing display quality may be employed to the LCD device.

[0051] In one exemplary embodiment, a plurality of a pixel electrode, indicated by 162 and 164 in FIGS. 1 and 2, is disposed on a single unit pixel area PA01 of the LCD device, and receives pixel voltages that are different from each other. A plurality of a micro slit portion, indicated by 161 and 165 in FIG. 2, is disposed to extend completely through the pixel electrodes 162 and 164, respectively, in order to enhance a viewing angle by varying alignment directions of liquid crystal molecules. A reactive mesogen layer is disposed on the pixel electrodes 162 and 164, and a common electrode of the

opposite substrate **201**, respectively, in order to enhance a response speed of the liquid crystal. The liquid crystal is aligned to have a pretilt angle directly by the reactive mesogen layer. The LCD device for enhancing display quality, and a method of manufacturing the LCD will be described.

[0052] In the illustrated embodiment, the array substrate **101** includes, as shown in FIGS. **1** and **2**, a plurality of a gate line **111**, a plurality of a data line **115**, a plurality of a storage line **116**, the plurality of pixel electrodes **162** and **164**, and a switching part. In the illustrated embodiment, two pixel electrodes **162** and **164** are disposed on the unit pixel area PA01. A first pixel electrode to which a relatively high level pixel voltage is applied may be denoted as a main pixel electrode, and a second pixel electrode to which a relatively low level pixel voltage is applied may be denoted as a sub-pixel electrode. In the illustrated embodiment of FIGS. **1** and **2**, the main pixel electrode is defined as the first pixel electrode **162**, and the sub-pixel electrode is defined as the second pixel electrode **164**.

[0053] The first and second pixel electrodes **162** and **164** are each electrically connected to a same gate line **111**, and are each electrically connected to different data lines **115**. Referring to FIGS. **1** and **2**, a pixel of the LCD device is driven in one gate line and two data line (1G2D) method. In the illustrated embodiment, the switching part includes a first switching element **122** and a second switching element **124**. The first switching element **122** electrically connects the first pixel electrode **162** to a first gate line **111** and a first data line **115**. The second switching element **124** electrically connects the second pixel electrode **164** to the first gate line **111** and a second data line **115** different from the first data line **115**, such as an adjacent data line **115**.

[0054] The storage line **116** includes a first (main) portion longitudinally extended in the row direction D1, and substantially parallel with the gate lines **111**. A plurality of a branch portion is protruded from the first portion and extended in the column direction D2 towards the first switching element **122** and the second switching element **124** in a plan view. A first branch portion **117** and a second branch portion **118** are substantially disposed within the unit pixel area PA01, where a portion of each of the first branch portion **117** and the second branch portion **118** overlaps with adjacent data lines **115** and the first pixel electrode **162**. A portion of the first (main) portion of the storage line **116** overlaps boundaries of both the first pixel electrode **162** and the second pixel electrode **164**.

[0055] The opposite substrate **201** includes a common electrode disposed to face the first and second pixel electrodes **162** and **164**. The first pixel electrode **162**, the common electrode and the liquid crystal layer **180** form a first liquid crystal capacitor C1c1, and the second pixel electrode **164**, the common electrode and the liquid crystal layer **180** form a second liquid crystal capacitor C1c2. The first pixel electrode **162** and a first storage line **116** together form a first storage capacitor Cst1, and the second pixel electrode **164** and the first storage line **116** together form a second storage capacitor Cst2.

[0056] Pixel voltages of the different levels may be applied to the first and second pixel electrodes **162** and **164**, respectively. In one exemplary embodiment, a first pixel voltage applied to the first pixel electrode **162** is higher than a second pixel voltage applied to the second pixel electrode **164**. Alternatively, a first pixel voltage applied to the first pixel electrode **162** is lower than a second pixel voltage applied to the second

pixel electrode **164**. When levels of the first and second pixel voltages are adjusted, images viewed at a side (e.g., not in a front) of a display screen of the LCD device may have substantially close to or the same display characteristics of an image viewed at substantially a front of the display screen of the LCD device. Advantageously, display quality is substantially uniform in accordance with the viewing angle, so that side visibility of the LCD device may be enhanced.

[0057] FIG. **3** is a flowchart illustrating an exemplary embodiment of a method of manufacturing an LCD device.

[0058] Summarizing a method of manufacturing the LCD device of the illustrated embodiment, a lower alignment layer is formed on the array substrate **101** including a pixel electrode including micro slit portions **161** and **165** formed there-through which determine an alignment direction of liquid crystal (step S10). A lower reactive mesogen layer is formed on the lower alignment layer (step S20). The liquid crystal layer **180** is disposed on the lower reactive mesogen ("RM") layer (step S30). The opposite substrate **201** is combined with the array substrate **101** (step S40). In a status in which an electric field is applied to the liquid crystal layer **180** through the first and second pixel electrodes **162** and **164**, light is irradiated to the opposite substrate **201** to provide a pretilt angle to liquid crystal (step S50).

[0059] Hereinafter, each manufacturing processes will be detail described.

[0060] FIG. **4** is a cross-sectional view taken along line IT of an array substrate **101** of FIG. **1**. FIG. **5** is a plan view illustrating an exemplary embodiment of an array substrate **101** excluding a pixel electrode of FIG. **1**. FIG. **6** is a plan view illustrating an exemplary embodiment of a pixel electrode of an array substrate **101** as illustrated in FIG. **1**.

[0061] Referring to FIGS. **4**, **5** and **6**, a lower alignment layer is formed on the array substrate **101** which includes the first and second pixel electrodes **162** and **164** including the micro slit portions **161** and **165**, which determine an alignment direction of liquid crystal, formed thereon (step S10).

[0062] The array substrate **101** includes a plurality of a gate line **111**, a plurality of a data line **115**, first and second switching elements **122** and **124** and first and second pixel electrodes **162** and **164** which are disposed on a lower base substrate **110**. In an exemplary embodiment, the lower base substrate **110** may include a glass material, but the invention is not limited thereto.

[0063] A gate metal is coated on the lower base substrate **110**. The coated gate metal is etched to form the gate lines **111**. The gate lines **111** are disposed on the lower base substrate **110** in parallel with a row direction D1 indicated in FIGS. **1** and **5**. A portion of each of the gate lines **111** forms a gate electrode **112** of a protruding shape. As shown in FIG. **4**, a gate insulation layer **121** is disposed on the gate lines **111**, and directly contacts both the gate lines **111** and the lower base substrate **110**.

[0064] A semiconductor layer and a source metal layer are sequentially formed on the gate insulation layer **121**. The source metal layer and the semiconductor layer are etched to form a plurality of a data line **115**, a source electrode **141**, a channel layer **131** and a drain electrode **143** as shown in FIGS. **4** and **5**. The data lines **115** are extended in a substantially column direction D2 indicated in FIG. **5**, and disposed on the gate insulation layer **121**. The source electrode **141** is extended from the data line **115** at a crossing area of the gate line **111** and the data line **115**, and overlaps with a portion of the gate electrode **112** as shown in FIGS. **4** and **5**. A first

portion of the drain electrode 143 is disposed on and overlapping the gate electrode 112 at an area overlapping with the source electrode 141, and a second portion of the drain electrode 143 is extended toward and completely overlapped by the unit pixel area PA01.

[0065] Referring to FIGS. 1 and 5, a pair of adjacent gate lines 111 and a pair of adjacent data lines 115 intersect each other to define a substantially rectangular area therebetween, and the first and second pixel electrodes 162 and 164 are disposed on the rectangular shaped area. An entire of both of the first and second electrodes 162 and 164 may be disposed between the pair of adjacent gate lines 111 and the pair of adjacent data lines 115. In the illustrated exemplary embodiment, the rectangular area will be defined as the unit pixel area PA01, but the invention is not limited thereto. Alternatively, a shape of the unit pixel area PA01 may be a different shape, such as Z-shape, and/or may not be defined by gate lines 111 and data lines 115.

[0066] Referring again to FIGS. 4 and 5, the gate electrode 112, the gate insulation layer 121, the channel layer 131, the source electrode 141 and the drain electrode 143 define the first switching elements 122, and form a three terminal element. The second switching element 124 may include a gate electrode 114, the gate insulation layer 121, the channel layer 131, a source electrode 142 and a drain electrode 144.

[0067] As shown in FIG. 4, the passivation layer 151 covering (e.g., overlapping) the data line 115 is disposed on the lower base substrate 110, and an organic insulation layer 153 is disposed on the passivation layer 151. A contact hole exposing a portion of the drain electrode 143 is extended through both the organic insulation layer 153 and the passivation layer 151.

[0068] An optically transparent and electrically conductive material layer, such as indium tin oxide ("ITO"), indium zinc oxide ("IZO"), amorphous indium tin oxide ("a-ITO"), etc., is disposed on the organic insulation layer 153, such as by a coating method. The optically transparent and electrically conductive material layer contacts with the drain electrode 143 through the contact hole. The optically transparent and electrically conductive material layer disposed on the organic insulation layer 153 is etched to form the first and second pixel electrodes 162 and 164 as shown in FIGS. 4 and 6. In the illustrated embodiment, in order to enhance a viewing angle, a viewing enhancing technology may be employed in the forming of the first and second pixel electrodes 162 and 164. In one exemplary, a technology in which an alignment direction of liquid crystal is divided into a plurality of domains that are different from each other may be employed to the unit pixel area PA01.

[0069] Referring to the illustrated exemplary embodiment in FIGS. 1 and 6, in order to obtain the domains, the first and second pixel electrodes 162 and 164 may include a plurality of supporting electrodes 163 and 167, and a plurality of micro slit portions 161 and 165, respectively. The supporting electrodes 163 and 167 may have substantially a bar shape. The supporting electrodes 163 and 167 may be disposed in a crossed shape defined by the row direction D1 and the column direction D2, for each of the first and second pixel electrodes 162 and 164, respectively.

[0070] Each of the supporting electrodes 163 and 167 may include a first portion longitudinally extending in the row direction D1, and a second portion longitudinally extending in the column direction D2. The first and second portions of each of the first and second pixel electrodes 162 and 164 may

intersect each other at substantially a 90 degree angle, but the invention is not limited thereto.

[0071] Each of the micro slit portions 161 and 165 may be respectively extended along a first oblique line direction D3 (FIGS. 1 and 5) and a second oblique line direction D4 (FIGS. 1 and 5), which each cross the row direction D3 and the column direction D2 with an angle of about 45 degrees, respectively. Each of the micro slit portions 161 and 165 may be formed to extend in different directions by domains be employed to the unit pixel area PA01.

[0072] Each of the micro slit portion 161 and 165 longitudinally extend obliquely with respect to the first and second portions of the supporting electrodes 163 and 167. In the plan view of FIG. 6, boundaries or edges of the first and second pixel electrodes 162 and 164 defined by distal ends of the supporting electrodes 163 and 167 and the micro slit portion 161 and 165 define a substantially rectilinear shape.

[0073] Referring to FIGS. 1, 4, 5 and 6, the first pixel electrode 162 may include a first connecting electrode portion 166 protruded from a group of micro slit portions 161 and overlapping the contact hole extended through both the organic insulation layer 153 and the passivation layer 151 which exposes the portion of the drain electrode 143 of the first switching element 122. The first connecting electrode portion 166 has a plan view dimension that is larger than both the micro slit portion 161 and the supporting electrode 163 portions. The first connecting electrode portion 166, the micro slit portion 161 and the supporting electrode 163 portions are electrically connected to each other and disposed as a single, continuous and indivisible member in the unit pixel area PA01.

[0074] Referring to FIGS. 1, 4, 5 and 6, the second pixel electrode 164 may include a second connecting electrode portion 169 protruded from a group of micro slit portions 165. A first end of the second connecting electrode portion 169 is continuously disposed with distal ends of the group of micro slit portions 165 from which it extends. The second connecting electrode portion 169 is longitudinally extended from the group of micro slit portions 165 in the column direction D2, and substantially parallel with the data lines 115. The second connecting electrode portion 169 is disposed between a data line 115 and an adjacent border of the first pixel electrode 162, as illustrated in the plan view of FIGS. 1 and 6.

[0075] Referring to FIGS. 1, 4, 5 and 6, the second pixel electrode 164 may further include a third connecting electrode portion 168 protruded from a second (e.g., distal) end of the second connecting electrode portion 169, and overlapping a contact hole extended through both the organic insulation layer 153 and the passivation layer 151 which exposes the portion of the drain electrode 144 of the second switching element 124. The second connecting electrode portion 169, the third connecting electrode portion 168, the micro slit portion 165 and the supporting electrode 167 portions are electrically connected to each other and disposed as a single, continuous and indivisible member in the unit pixel area PA01.

[0076] A long axis of the liquid crystal may be arranged substantially in parallel with an extended direction of the micro slit portions 161 and 165. As a result, a plurality of domains is formed to enhance a viewing angle of the LCD device. A lower polarizing plate (not shown) may be attached at a rear surface (e.g., a lowermost surface in FIG. 4) of the lower base substrate 110.

[0077] In one exemplary embodiment, the micro slit portions **161** and **165** disposed through the first and second pixel electrodes **162** and **164** may be obliquely extended in a direction forming at an angle of about 45 degrees or about 135 degrees with respect to a lower polarizing axis of the lower polarizing plate, such as the first oblique line direction **D3** and the second oblique line direction **D4**.

[0078] FIG. 7 is a cross-sectional view illustrating an exemplary embodiment of a process for manufacturing a lower alignment layer **171** on an array substrate **101** of FIG. 4.

[0079] Referring to FIG. 7, the lower alignment layer **171** covering the first and second pixel electrodes **162** and **164** is formed (step **810**). The lower alignment layer **171** is disposed overlapping and directly contacting each of the first and second pixel electrodes **162** and **164**, and the organic insulating layer **153**.

[0080] In an exemplary embodiment, the lower alignment layer **171** may be formed by coating a photo-reactive polymer of a cinematic series, and a polymer blend of a polyimide series on the first and second pixel electrodes **162** and **164** and curing the coated photo-reactive polymer and the polymer blend. In one exemplary embodiment, the photo-reactive polymer of a cinematic series and the polymer blend of a polyimide series are blended in a ratio of about 1:9 (weight percent) to 9:1 (weight percent) to melt in an organic solvent, and then the polymer melted in the organic solvent is coated on the substrate, such as in a spin coating method. The coated polymer is cured, such as by heating, so that the lower alignment layer **171** may be formed.

[0081] An ultraviolet ("UV") light is irradiated on the lower alignment **171** to generate an alignment force characteristic for a liquid crystal layer **180**. By using the light alignment process, the lower alignment layer **171** may align liquid crystal of the liquid crystal layer **180** substantially in a vertical direction, that is, a direction from the array substrate **101** to the opposite substrate **201** which is substantially perpendicular to both the array substrate **101** to the opposite substrate **201**.

[0082] FIG. 8 is a process diagram illustrating an exemplary embodiment of a process for manufacturing a lower RM layer **190** on the lower alignment layer **171** through a spray method. FIG. 9 is a process diagram illustrating an exemplary embodiment of a process for manufacturing a lower RM layer **190** on the lower alignment layer **171** through a coating method. FIG. 10 is a cross-sectional view illustrating another exemplary embodiment of a process for manufacturing a lower RM layer **190** on a lower alignment layer **171**.

[0083] Referring to FIG. 3, the lower RM layer **190** is formed on the lower alignment layer **171** (step **S20**). The lower RM layer **190** may be used to enhance a response speed of the LCD device by allowing a pretilt angle to the liquid crystal layer **180**. A term of the "mesogen" is used to define a light bridge high-molecular copolymer polymer including a mesogen group of a liquid crystal property. When a polarized UV light is irradiated to the mesogen, anisotropy of the mesogen is induced, and then a heat process is performed to enhance a direction property of liquid crystal.

[0084] In the illustrated embodiment, the mesogen group is a polymer material which has a liquid crystal property at a predetermined temperature range or a liquid solution state. The reactive mesogen RM may include a material or compound including one or more rod-shaped, banana-shaped, board-shaped or disk-shaped mesogenic groups, i.e. groups capable of showing liquid crystal phase behavior. The RM

may include mesogen having acrylate, metacrylate, epoxy, oxetanes, vinyl ether, styrene, thiophene, etc.

[0085] In one illustrated exemplary embodiment, the mesogen blend **RM01** including the RM may be coated on the lower alignment layer **171** through a spray method using a spray nozzle **SP01** as shown in FIG. 8. Alternatively, as shown in FIG. 9, the mesogen blend **RM01** may be coated on the lower alignment layer **171** through a spin coating method using a coating nozzle **NZ01**. The mesogen blend **RM01** may include a free radical initiator having photosensitivity or heat sensitivity, and/or a polymer initiator such as a cationic agent. The initiator may be operated by light or heat. The mesogen blend **RM01** may include a composition such as at least one of polymer initiators.

[0086] After the mesogen blend **RM01** is applied to the lower alignment layer **171** (FIGS. 8 and 9), a volatile composition is removed from the mesogen blend **RM01**, and the lower RM layer **190** is formed on the lower alignment layer **171** as shown in FIG. 10. The lower RM layer **190** may be disposed on essentially a whole of the array substrate **101**, and overlapping and directly contacting the organic insulating layer **153**.

[0087] When liquid crystal is arranged on the lower alignment layer **171**, the lower RM layer **190** is aligned in an alignment direction of the lower alignment layer **171** to induce the liquid crystal to have a pretilt angle. In order not to cure the lower RM layer **190**, an incident light provided from an external side may be blocked to the lower RM layer **190** during the spray process or the spin coating process.

[0088] FIG. 11 is a cross-sectional view illustrating an exemplary embodiment of a process for manufacturing a diffusion stop layer on a surface of a lower RM layer **190**.

[0089] In the method of manufacturing the LCD device, a liquid crystal layer **180** is disposed on the lower RM layer **190**. Since the lower RM layer **190** is not cured when the liquid crystal layer **180** is disposed on the lower RM layer, the RM in the lower RM layer **190** may be distributed to the liquid crystal layer **180**. When an amount of RM mixed to the liquid crystal layer **180** is relatively large, a generation of an undesirable afterimage may be increased in an LCD device. Referring to FIG. 11, a diffusion stop layer (not shown) may be formed on the lower RM layer **190**, in order to suppress the RM in the lower RM layer **190** from being transferred into the liquid crystal layer **180**. In an exemplary embodiment, the diffusion stop layer is a relatively thin film into which characteristics of a surface of the lower RM layer **190** are varied. The diffusion stop layer is disposed between the lower RM layer **190** and the liquid crystal layer **180**.

[0090] In one exemplary embodiment, a UV light of which strength and time are properly controlled, is irradiated to a surface of the lower RM layer **190** (as indicated by **H01** in FIG. 11) to soft light cure the surface of the lower RM layer **190**, so that the diffusion stop layer may be formed. Alternatively, an infrared ray of which strength and time are properly controlled is irradiated to a surface of the lower RM layer **190** to soft heat cure the surface of the lower RM layer **190**, so that the diffusion stop layer may be formed.

[0091] In an alternative embodiment, when adhesive characteristics between the lower RM layer **190** and the lower alignment layer **171**, and chemical composition of the RM are properly controlled and selected, the amount of the RM disposed in the liquid crystal layer **180** may be decreased even though the diffusion stop layer is not formed. Therefore, a formation process of the diffusion stop layer may be omitted.

[0092] FIG. 12 is a cross-sectional view illustrating an exemplary embodiment of a process for disposing a liquid crystal layer 180 on a lower RM layer 190.

[0093] A liquid crystal layer 180 is disposed on the lower RM layer 190 as shown in FIG. 12, after the formation process of the diffusion stop layer or after the formation process of the lower RM layer 190 (step S30). Liquid crystals 181 are disposed on the lower RM layer 190, such as through a direct drop method, so that the liquid crystal layer 180 may be disposed on the lower RM layer 190.

[0094] FIG. 13 is a cross-sectional view illustrating an exemplary embodiment of a process for combining an array substrate 101 including a liquid crystal layer 180 disposed thereon, and an opposite substrate 201.

[0095] As shown in FIG. 13, the opposite substrate 201 is combined with the array substrate 101 (step S40).

[0096] The opposite substrate 201 may include an upper base substrate 210, a light-blocking pattern 221, a color filter pattern 231, an overcoating layer 241, a common electrode 251 and an upper alignment layer 261.

[0097] The light-blocking pattern 221 is disposed on the upper base substrate 210 in correspondence with (e.g., overlapped with portions of) the gate line 111, the data line 115, the first and second switching elements 122 and 124 and the storage line 116. The light-blocking pattern 221 may not be disposed overlapping the unit pixel area PA01. The color filter pattern 231 is disposed on the unit pixel area PA01 which is not blocked by light. In an exemplary embodiment, the color filter pattern 231 may include, but is not limited to, a red color filter, a green color filter and a blue color filter. The red, green and blue color filters may be sequentially disposed in correspondence with each unit pixel area PA01 in a column direction D1.

[0098] The overcoating layer 241 overlaps the color filter pattern 231 and the light-blocking pattern 221, such being disposed on an entire of the upper base substrate 210. The common electrode 251 is disposed on the overcoating layer 241 and opposite to the upper base substrate 210 with respect to the overcoating layer 241. In the illustrated embodiment, a material of the common electrode 251 is same as that of the first and second pixel electrodes 162 and 164.

[0099] Where the common electrode 251 is disposed corresponding substantially to the unit pixel area PA01, the common electrode 251 may be formed in a substantially flat plate shape in which slit portions, that is, an opening is not formed. The common electrode 251 may be disposed as a single, continuous and indivisible member as including no openings. In the illustrated embodiment, when micro slit portions 161 and 165 are formed in the first and second pixel electrodes 162 and 164, respectively, and the common electrode 251 is formed in a substantially continuous flat plate shape in which slit portions are not formed, a liquid crystal cell type is called as a super-vertical alignment ("S-VA") mode. Alternatively, the liquid crystal layer 180 may be driven in a pattern vertical alignment ("PVA") mode. In the PVA mode, a plurality of slit portions for forming a fringe field on each of the first pixel electrode 162, the second pixel electrode 164 and the common electrode 251 may be disposed.

[0100] Referring again to FIG. 13, the upper alignment layer 261 is disposed on the common electrode 251. In an exemplary embodiment, a material of the upper alignment layer 261 is same as that of the lower alignment layer 171.

[0101] An upper RM layer 290 may be disposed on the upper alignment layer 261 by using the same method if form-

ing the lower RM layer 190, that is, the spray method or the coating method as described above.

[0102] In an exemplary embodiment, an upper polarizing plate (not shown) may be disposed on an outer surface of the opposite substrate 201, such as to form an outermost layer of the LCD device. A polarizing axis of the upper polarizing plate may be substantially perpendicular to that of the lower polarizing plate.

[0103] Prior to applying an electric field between the first and second pixel electrodes 162 and 164 of the array substrate 101, and the common electrode 251 of the opposite substrate 201, a long axis direction of liquid crystal 181 (hereinafter, referred to as a director of liquid crystal) may be aligned in a direction substantially perpendicular to the array substrate 101 and the opposite substrate 201 as shown in FIG. 13.

[0104] FIGS. 14 and 15 are cross-sectional views illustrating an exemplary embodiment of a process for allowing a pretilt angle of liquid crystal molecules 181.

[0105] Referring to FIGS. 14 and 15, light 7 is irradiated to the liquid crystal layer 180 through the opposite substrate 201 to affect a pretilt angle to the liquid crystal 181 at a surface of the lower RM layer 190 and a surface of the upper RM layer 290 (step S50).

[0106] When the pixel voltage is applied to the first and second pixel electrodes 162 and 164, and when the common voltage is applied to the common electrode 251, the director of the liquid crystal 181 is aligned in substantially a horizontal direction as shown in FIG. 14. Thus, a white driving mode may be realized. In exemplary embodiments, in order to fully align the director of the liquid crystal 181, the pixel voltage and the common voltage may be increased.

[0107] In the white driving mode, as shown in FIG. 14, an ultraviolet light 7 is irradiated on the opposite substrate 201. The lower RM layer 190 and the upper RM layer 290 are cured at surfaces of the lower RM layer 190 and the upper RM layer 290 adjacent to the lower and upper alignment layers 171 and 261, respectively, to determine a direction property of liquid crystal 181 in response to the ultraviolet light.

[0108] Referring to FIG. 15, the liquid crystals 181a and 181b directly adjacent to the lower and upper RM layers 190 and 290, respectively, may be substantially fixed in a direction in which the liquid crystals 181a and 181b are arranged in the horizontal direction. When an electric field is not applied to the liquid crystal layer 180, as shown in FIG. 15, liquid crystals are arranged. That is, liquid crystals 181a and 181b horizontally lie down at surfaces of the lower RM layer 190 and the upper RM layer 290 adjacent to the liquid crystal layer 180, or have an inclined angle with respect to surfaces of the lower RM layer 190 and the upper RM layer 290. For the liquid crystals located closer to a middle of liquid crystal layer between the array substrate 101 and the opposite substrate 201, the liquid crystals 181c are gradually arranged substantially perpendicular with respect to surfaces of the lower RM layer 190 and the upper RM layer 290 as a distance increases from the array substrate 101 and the opposite substrate 201.

[0109] Due to the arrangement of the liquid crystal 181, a response time of the liquid crystal 181 may be advantageously enhanced. Moreover, arrangement directions of the liquid crystal are various, so that a viewing angle may be advantageously enhanced.

[0110] In the illustrated embodiment, the RM of the lower and upper RM layers 190 and 290 are not mixed with the liquid crystal 181 to be cured through a UV light, at a condition in which the RM is coated on surfaces of the lower

alignment layer 171 and the upper alignment layer 261. Advantageously, as described above, the RM is not mixed with the liquid crystal layer 180.

[0111] FIG. 16 is a cross-sectional view illustrating an exemplary embodiment of a generation of a remaining reactive mesogen layer in the LCD device which liquid crystals and reactive mesogen material are blended to form a liquid crystal layer 580. In FIG. 16, a hatched pattern represents a liquid crystal molecule, and a non-hatched pattern represents a reactive mesogen.

[0112] Referring to FIG. 16, different from the previously illustrated embodiment, instead of forming a RM layer by coating the reactive mesogen on a lower alignment layer 571 and an upper alignment layer 661, a light curing process may be performed at a mixture state of the RM into the liquid crystal layer 580. The light curing method for the RM will be designated as a "blend method," and the light curing method for the RM such as described for the previously illustrated embodiment will be designated as a "coating method" or "deposition method."

[0113] According to the blend method, as shown in FIG. 16, the reactive mesogen RM04 disposed at a relatively far distance from the lower alignment layer 571 and the upper alignment layer 661 is influenced by the lower alignment layer 571 and the upper alignment layer 661, rather than reactive mesogens RM02 and RM03 adjacent to and disposed closer to the lower alignment layer 571 and the upper alignment layer 661, respectively. In a manufacturing process, the adjacent reactive mesogens RM02 and RM03 are cured at a surface of the lower alignment layer 571 and the upper alignment layer 661 to form a lower RM layer 590 and an upper RM layer 690, respectively. However, the reactive mesogen RM04 disposed further from the lower alignment layer 571 and the upper alignment layer 661 is not cured, and remains in the liquid crystal layer 580.

[0114] An undesirable decreasing amount of liquid crystal alignment capability due to the remaining reactive mesogen RM04 in the liquid crystal layer 580, is called as an alignment losing ratio. The alignment losing ratio depends upon not only characteristics of liquid crystal composition such as elasticity and viscosity, but also depends upon a chemical composition of the lower alignment layer 571 and the upper alignment layer 661, and characteristics of pattern formed on an alignment layer.

[0115] FIG. 17 is a graph illustrating a relationship between an amount of the RM which is remaining in the liquid crystal layer 580 of the LCD device as described in FIG. 16 (blend method) and an exposing time, and an amount of the RM which is remaining in the liquid crystal layer of the LCD device as described in FIGS. 1 to 15 (deposition method) and an exposing time.

[0116] In FIG. 17, a horizontal axis represents an exposing strength (J/cm^2) of a UV light used to a light curing process for the RM, and a vertical axis represents a mass ratio of RM amount which is not cured after a light curing process and remains within the liquid crystal layer 580 with respect to a mass of an initially inputted RM. The RM remaining amount corresponding to the blend method (FIG. 16) is based on an amount of mixture RM of the liquid crystal layer 580, and the RM remaining amount corresponding to a coating method (FIGS. 1-15) is based on an amount of RM included in the lower RM layer 190 and the upper RM layer 290.

[0117] As shown in FIG. 17, observing the graph of the RM remaining amount of the blend method of FIG. 16, the RM

remaining amount is gradually decreased as a time increases, such as shown that the RM remaining amount is close to about 35 weight percent (wt %). That is, even though an exposing time is relatively long, it is recognized the RM remaining amount decreases close to a uniform threshold value, that is, the RM remaining amount does not continuously decrease.

[0118] When observing the graph of RM remaining amount of a coating method of FIGS. 7-15, the RM remaining amount is about 15 wt % initially, and it is shown that the RM remaining amount is maintained to be about 12 wt % after the coating process is completed.

[0119] That is, the RM is diffused into the liquid crystal layer 180 through the coating method, however, the RM remaining amount is about $\frac{1}{3}$ of the blend method. Thus, in the coating method, the decreasing of display quality due to the remaining reactive mesogen RM04 may be reduced or effectively prevented since the RM remaining amount is about $\frac{1}{3}$ of the blend method.

[0120] An LCD structure including a remaining amount of reactive mesogen in the liquid crystal layer may be formed using an exemplary embodiment of the light curing method for the RM, designated as a "blend method," and an exemplary embodiments of the light curing method for the RM designated as a "coating method" or "deposition method." The remaining amount of reactive mesogen in the liquid crystal layer is considered as a distinctive structural characteristic of the LCD.

[0121] Since the remaining amount of reactive mesogen in the liquid crystal layer is imparted by forming a reactive mesogen layer on an alignment layer of a first substrate, disposing a liquid crystal layer on the lower alignment layer, combining the first substrate with a second substrate and irradiating the combined substrates to generate a pretilt angle in the liquid crystal layer of the coating method, such a process is considered as imparting the distinct structural characteristic of the remaining amount of reactive mesogen in the liquid crystal layer. Additionally, since the remaining amount of reactive mesogen in the liquid crystal layer is imparted by form a reactive mesogen layer through coating a mixture of the reactive mesogen and liquid crystal on a lower alignment layer and an upper alignment layer, and light curing the mixture state of the RM into the liquid crystal layer, such a process is also considered as imparting the distinct structural characteristic of the remaining amount of reactive mesogen in the liquid crystal layer.

[0122] FIGS. 18A and 18B are cross-sectional views illustrating an exemplary embodiment of a pretilt angle of liquid crystal molecules at a black driving area B01 and a white driving area W01, of an LCD device manufactured by the blending method as described in FIG. 16.

[0123] Referring to FIGS. 18A and 18B, the liquid crystal 581 is substantially vertically aligned and backlight (indicated by the upward arrows) is blocked at a black driving area B01 of the LCD device manufactured by the blend method, so that black is displayed. The liquid crystal 581 is substantially horizontally aligned and backlight is transmitted at a white driving area W01 of the LCD device manufactured by the blend method, so that white is displayed. In the blend method, the remaining RM RM04 of the liquid crystal layer 580 responds to the backlight BL01 during the black driving and the white driving, and then the remaining RM RM04 is additionally cured at a surface of the lower RM layer 590 and the

upper RM layer **690**. Accordingly, a pretilt angle of the liquid crystal **581** is altered at a surface of the lower RM layer **590** and the upper RM layer **690**.

[0124] Additional curing amounts of the RM are different from each other at the black driving area **B01** and the white driving area **W01**. Thus, as shown in FIG. **18B**, when an electric field is turned off, that is, even though a total display screen is displayed in black, pretilt angles of the liquid crystal **581** may be different from each other at the black driving area **B01** and areas which were the white driving area **W01**.

[0125] FIGS. **19A** and **19B** are photographs illustrating an exemplary embodiment of a display screen of the LCD device manufactured by the blending method as described in FIG. **16**. FIG. **19A** shows a display screen that is observed when a total display screen is displayed in black after the white driving area **W01** is driven in about 220-gray with respect to the black driving area **B01** for about 24 hours at a peripheral temperature of about 50 Celsius degrees. FIG. **19B** shows a display screen that is observed when a total display screen is displayed in black after the white driving area **W01** is driven in about 245-gray with respect to the black driving area **B01** for about 168 hours at a peripheral temperature of about 50 Celsius degrees.

[0126] Referring to FIGS. **19A** and **19B**, in the aforementioned blend method, pretilt angles of the liquid crystal **581** are different from each other in accordance with the black driving area **B01** and the white driving area **W01**, so that a gradation displayed at a black status may be different from each other in accordance with areas and lapse time. Therefore, an undesirable afterimage may be clearly observed on the display screen. That is, display quality may be greatly decreased.

[0127] FIGS. **20A** and **20B** are photographs illustrating a display screen of the LCD device as described in FIGS. **1** to **15**. FIG. **20A** shows a display screen that is observed when a total display screen is displayed in black after the white driving area **W01** is driven in about 90-gray with respect to the black driving area **B01** for about 24 hours at a peripheral temperature of about 50 Celsius degrees. FIG. **20B** shows a display screen that is observed when a total display screen is displayed in black after the white driving area **W01** is driven in about 180-gray to about 200-gray with respect to the black driving area **B01** for about 168 hours at a peripheral temperature of about 50 Celsius degrees.

[0128] Referring to FIGS. **20A** and **20B**, the remaining RM **RM04** within the liquid crystal layer **180** is decreased in a coating method such as the present embodiment, so that an additional curing of the reactive mesogen due to the backlight **BL01** at the black driving area **B01** and the white driving area **W01** while an LCD device is driven is not generated. Thus, the pretilt angle of the liquid crystal **181** may be uniform in accordance with areas. As a result, it is recognized that an afterimage is not viewed even though a lapse time is about 168 hours as shown in FIG. **20B**.

[0129] According to exemplary embodiment of an LCD device and a method of manufacturing the LCD device, in an LCD device which allows a pretilt angle by using a reactive mesogen, the remaining reactive mesogen remaining within a liquid crystal layer may be decreased. Advantageously, an afterimage due to the remaining reactive mesogen in a display screen may be removed, so that display quality may be enhanced. Therefore, the illustrated embodiments may be adapted to an LCD device using a reactive mesogen.

[0130] The foregoing is illustrative of the present invention and is not to be construed as limiting thereof. Although exemplary embodiments of the present invention have been described, those skilled in the art will readily appreciate that many modifications are possible in the exemplary embodiments without materially departing from the novel teachings and advantages of the present invention. Accordingly, all such modifications are intended to be included within the scope of the present invention as defined in the claims. In the claims, means-plus-function clauses are intended to cover the structures described herein as performing the recited function and not only structural equivalents but also equivalent structures. Therefore, it is to be understood that the foregoing is illustrative of the present invention and is not to be construed as limited to the specific exemplary embodiments disclosed, and that modifications to the disclosed exemplary embodiments, as well as other exemplary embodiments, are intended to be included within the scope of the appended claims. The present invention is defined by the following claims, with equivalents of the claims to be included therein.

What is claimed is:

1. A liquid crystal display device comprising:

an array substrate comprising:

- a lower substrate including a switching electrode disposed thereon;
- a pixel electrode electrically connected to the switching electrode; and
- a lower alignment layer disposed on the pixel electrodes to induce an inclined direction of liquid crystal molecules, and comprising a lower reactive mesogen layer which comprises reactive mesogen material;

an opposite substrate comprising:

- an upper substrate disposed facing the lower substrate of the array substrate;
- a common electrode disposed on the upper substrate, and facing the pixel electrode; and
- an upper alignment layer disposed on the common electrode, and comprising an upper reactive mesogen layer which comprises reactive mesogen material; and

a liquid crystal layer disposed between the array substrate and the opposite substrate and comprising the liquid crystal molecules

2. The LCD device of claim 1, wherein

the liquid crystal layer directly contacts to the lower reactive mesogen layer and the upper reactive mesogen layer.

3. The LCD device of claim 2, wherein a weight of reactive mesogen material in the liquid crystal layer is no more than about 20 weight percent (wt %) with respect to a weight of the lower and upper reactive mesogen layers.

4. The LCD device of claim 3, further comprising:

a diffusion stop layer disposed on the inner surfaces of the lower reactive mesogen layer and the upper reactive mesogen layer to block the lower reactive mesogen layer and the upper reactive mesogen layer from being diffused to the liquid crystal layer.

5. The LCD device of claim 2, wherein the pixel electrode comprises a first pixel electrode and a second pixel electrode which are disposed on the unit pixel area to respectively receive different pixel voltages, and the slit portions are disposed on a plurality of domains of the first and second pixels, respectively, in the different directions.

6. The LCD device of claim 5, wherein the common electrode disposed facing the first and second pixel electrodes has a substantially flat plate shape which does not have an opening.

7. The LCD device of claim 5, wherein the lower alignment layer and the upper alignment layer are aligned to vertically arrange a long axis of the liquid crystal molecules when an electric field applied to the liquid crystal layer is turned off.

8. The LCD device of claim 5, wherein the lower alignment layer and the upper alignment layer are aligned to arrange a long axis of the liquid crystal molecules in an extending direction of the slit portion at each of the domains when an electric field applied to the liquid crystal layer is turned off.

9. The LCD device of claim 1, wherein

the pixel electrode comprises a plurality of a slit portion disposed on a plurality of domains and extended in different directions.

10. A method of manufacturing a liquid crystal display device, the method comprising:

forming a lower alignment layer on an array substrate comprising a pixel electrode to induce an alignment direction of liquid crystal molecules;

forming a lower reactive mesogen layer on the lower alignment layer;

disposing a liquid crystal layer comprising liquid crystal molecules on the lower reactive mesogen layer;

coupling an opposite substrate with the array substrate; and irradiating light at a condition in which an electric field is applied to the liquid crystal layer through the pixel electrode to provide a pretilt angle to the liquid crystal molecules at a surface of the lower reactive mesogen layer.

11. The method of claim 10, further comprising:

forming an upper alignment layer on a common electrode of the opposite substrate before the opposite substrate is coupled with the array substrate; and

forming an upper reactive mesogen layer on the upper alignment layer.

12. The method of claim 11, wherein the common electrode is disposed facing the pixel electrode and has a substantially flat plate shape which does not have an opening.

13. The method of claim 12, wherein forming the lower reactive mesogen layer and forming the upper reactive mesogen layer comprise:

coating a reactive mesogen blend including a reactive mesogen material on the lower alignment layer and the

upper alignment layer, respectively, through a spray method or a coating method.

14. The method of claim 13, wherein a weight of uncured reactive mesogen material, which is diffused from the lower and upper reactive mesogen layers to the liquid crystal layer, is no more than about 20 weight percent (wt %) with respect to an initial weight of the lower and upper reactive mesogen layer.

15. The method of claim 13, wherein a weight of uncured reactive mesogen material, which is diffused from the lower and upper reactive mesogen layers to the liquid crystal layer, is no more than about 1.0 weight percent (wt %) with respect to an initial weight of the lower and upper reactive mesogen layer.

16. The method of claim 15, further comprising:

forming a diffusion stop layer to block the reactive mesogen layer from being diffused to the liquid crystal layer on inner surfaces of the lower reactive mesogen layer and the upper reactive mesogen layer, the forming the diffusion layer includes heat processing or a light reactive processing the inner surfaces of the lower reactive mesogen layer and the upper reactive mesogen layer before the liquid crystal layer is disposed.

17. The method of claim 11, wherein the forming the lower alignment layer and the upper alignment layer comprises:

coating a blend including at least one of photo-reactive polymer of a cinemetic series and a polymer of a polyimide series on the pixel electrode and the common electrode.

18. The method of claim 17, wherein the pixel electrode comprises a first pixel electrode and a second pixel electrode, the first pixel electrode and the second pixel electrode formed on a unit pixel area of the array substrate, and the slit portions are formed in different directions on a plurality of domains defined on each of the first and second pixel electrodes.

19. The method of claim 18, wherein the lower alignment layer and the upper alignment layer are aligned so that a long axis of the liquid crystal molecules is vertically aligned.

20. The method of claim 18, wherein the lower alignment layer and the upper alignment layer are aligned so that the long axis of the liquid crystal molecules is arranged in an extending direction of the slit portion at each of the domains.

* * * * *

专利名称(译)	液晶显示装置及其制造方法		
公开(公告)号	US20140293203A1	公开(公告)日	2014-10-02
申请号	US14/303775	申请日	2014-06-13
[标]申请(专利权)人(译)	三星显示有限公司		
申请(专利权)人(译)	三星DISPLAY CO. , LTD.		
当前申请(专利权)人(译)	三星DISPLAY CO. , LTD.		
[标]发明人	KYE MYEONG HA LEE JUN HYUP LYU JAE JIN PARK SEUNG BEOM SON JONG HO SOHN JI WON KIM HOON SEOK MIN GOO NA JUN HEE KIM MIN JAE WOO SU HAN		
发明人	KYE, MYEONG-HA LEE, JUN-HYUP LYU, JAE-JIN PARK, SEUNG-BEOM SON, JONG-HO SOHN, JI-WON KIM, HOON SEOK, MIN-GOO NA, JUN-HEE KIM, MIN-JAE WOO, SU-HAN		
IPC分类号	G02F1/1337		
CPC分类号	G02F1/133707 G02F1/133711 G02F1/133788 G02F2201/501 G02F2001/133397 G02F2001/133726 G02F2001/134345 G02F1/13624		
优先权	1020080106521 2008-10-29 KR		
其他公开文献	US9244310		
外部链接	Espacenet USPTO		

摘要(译)

一种液晶显示装置，包括阵列基板，相对基板和液晶显示层。阵列基板包括像素电极和下部反应性液晶元层。像素电极包括沿不同方向设置在多个域上的多个狭缝部分。较低反应性液晶元层设置在像素电极上以引起液晶分子的倾斜方向。相对基板包括上基板。上反应性液晶元层设置在相对基板的公共电极上。液晶层包括液晶分子，该液晶分子被布置成在下部反应性液晶元层的表面和上部反应性液晶元层的表面之间具有预倾角。

