



US 20150226989A1

(19) **United States**
(12) **Patent Application Publication**
Lee et al.

(10) **Pub. No.: US 2015/0226989 A1**
(43) **Pub. Date: Aug. 13, 2015**

(54) **SUBSTRATE AND LIQUID CRYSTAL DISPLAY DEVICE INCLUDING THE SAME**

Publication Classification

(71) Applicant: **LG DISPLAY CO., LTD.**, Seoul (KR)

(51) **Int. Cl.**
G02F 1/1337 (2006.01)
G02F 1/1339 (2006.01)
G02F 1/1335 (2006.01)
G02F 1/1368 (2006.01)
G02F 1/1362 (2006.01)

(72) Inventors: **Jaе-Won Lee**, Goyang-si (KR);
So-Young Noh, Seoul (KR); **Sung-Ki Kim**, Goyang-si (KR); **Jin-Pil Kim**, Paju-si (KR); **Kyung-Mo Son**, Paju-si (KR)

(52) **U.S. Cl.**
CPC *G02F 1/1337* (2013.01); *G02F 1/1368* (2013.01); *G02F 1/136286* (2013.01); *G02F 1/133512* (2013.01); *G02F 1/133514* (2013.01); *G02F 1/1339* (2013.01)

(73) Assignee: **LG DISPLAY CO., LTD.**

(21) Appl. No.: **14/690,775**

(22) Filed: **Apr. 20, 2015**

(57) **ABSTRACT**

Related U.S. Application Data

A substrate for a liquid crystal display device includes: a substrate including a display region displaying an image and a non-display region surrounding the display region; a dummy pattern in the non-display area over the substrate, the dummy pattern having a length that corresponds to a side of the display area; and an orientation film on the dummy pattern, the orientation film covering the non-display area and the whole display area.

(62) Division of application No. 13/275,991, filed on Oct. 18, 2011, now Pat. No. 9,046,715.

Foreign Application Priority Data

(30) Oct. 18, 2010 (KR) 10-2010-0101313

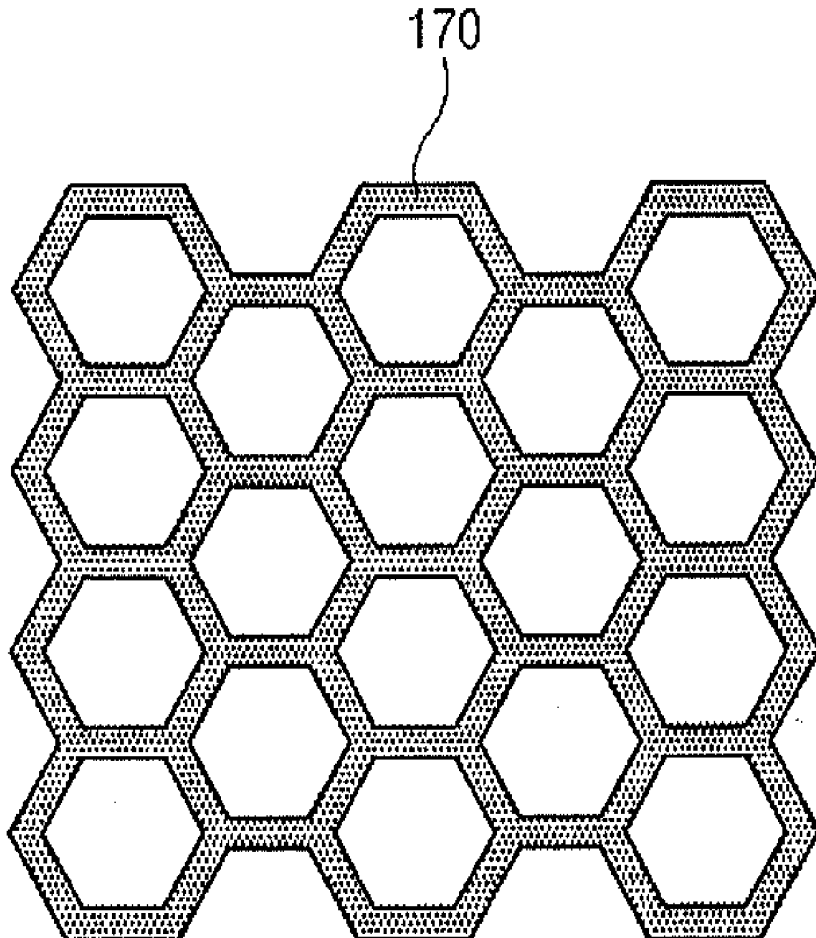

FIG. 1
Related Art

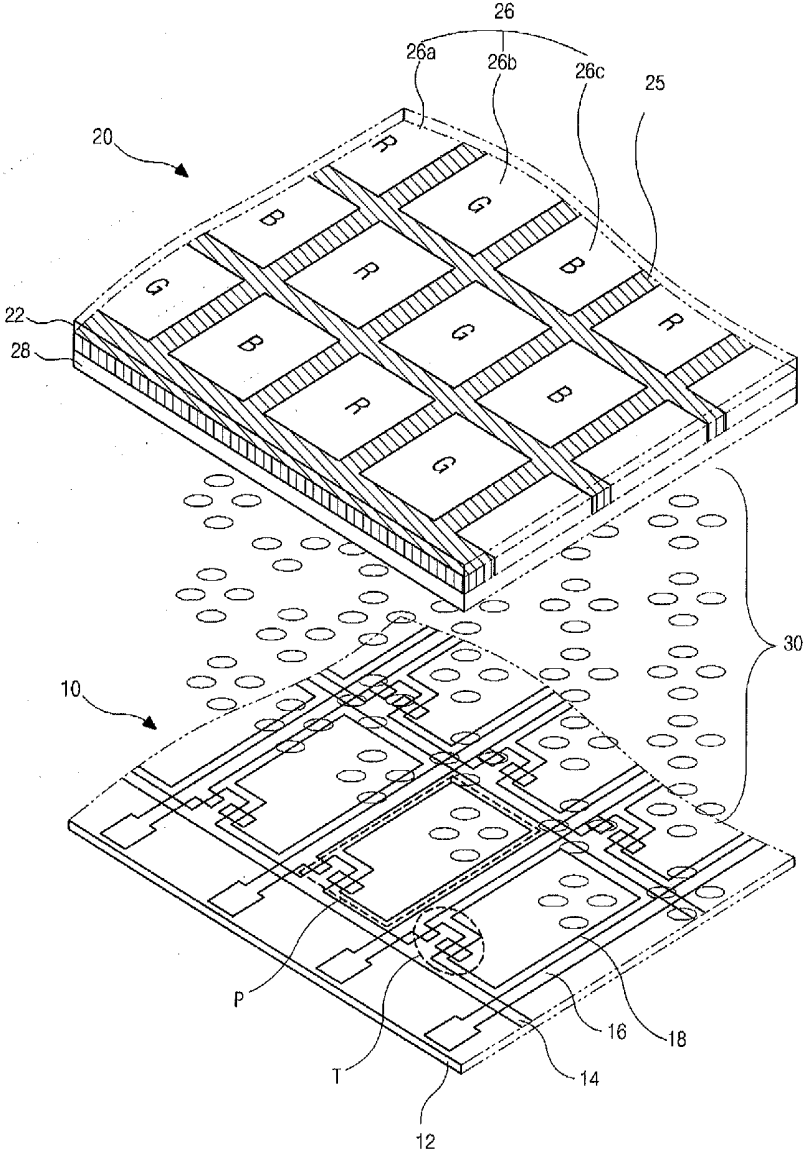

FIG. 2
Related Art

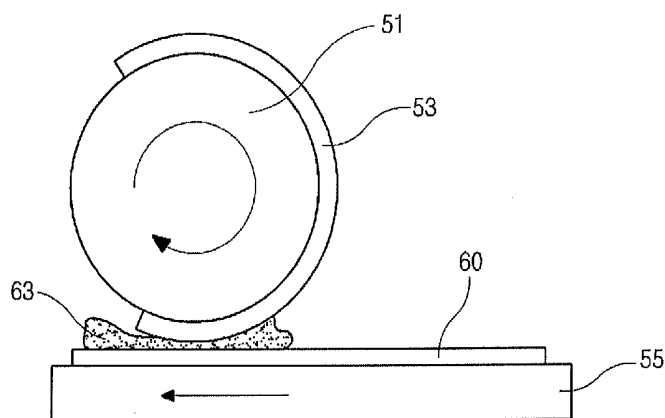

FIG. 3
Related Art

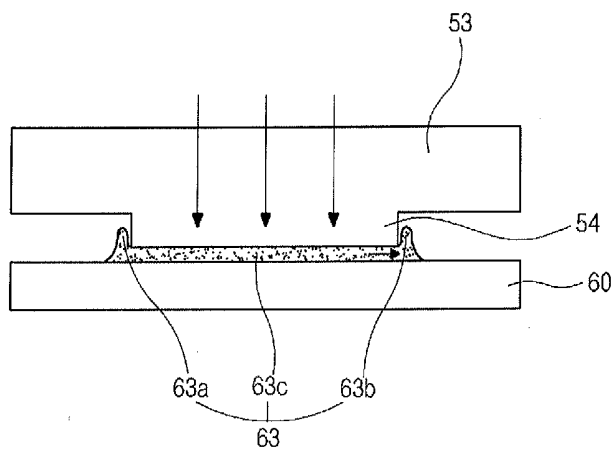

FIG. 4A

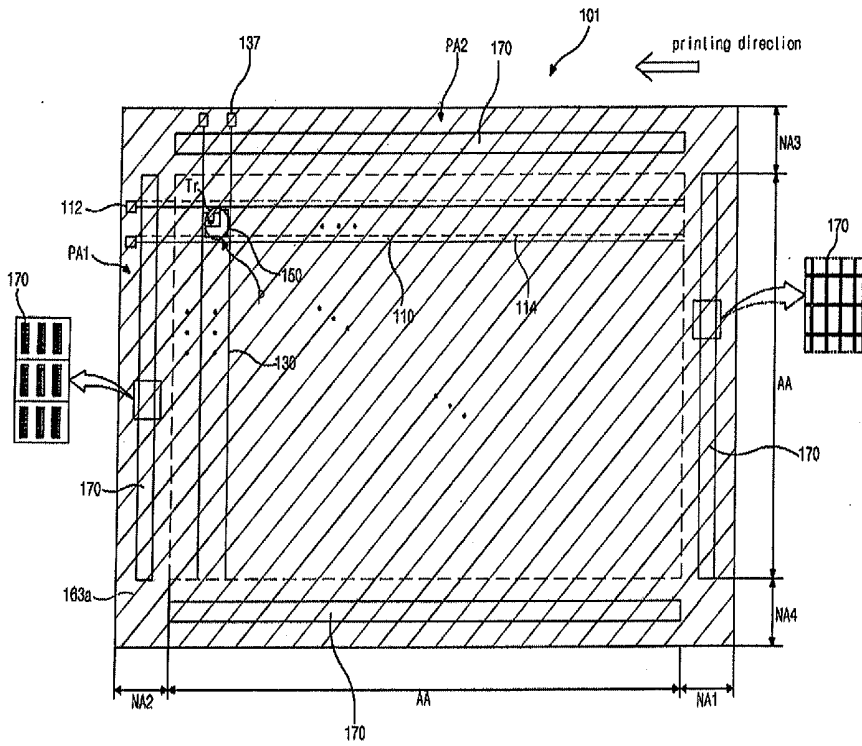

FIG. 4B

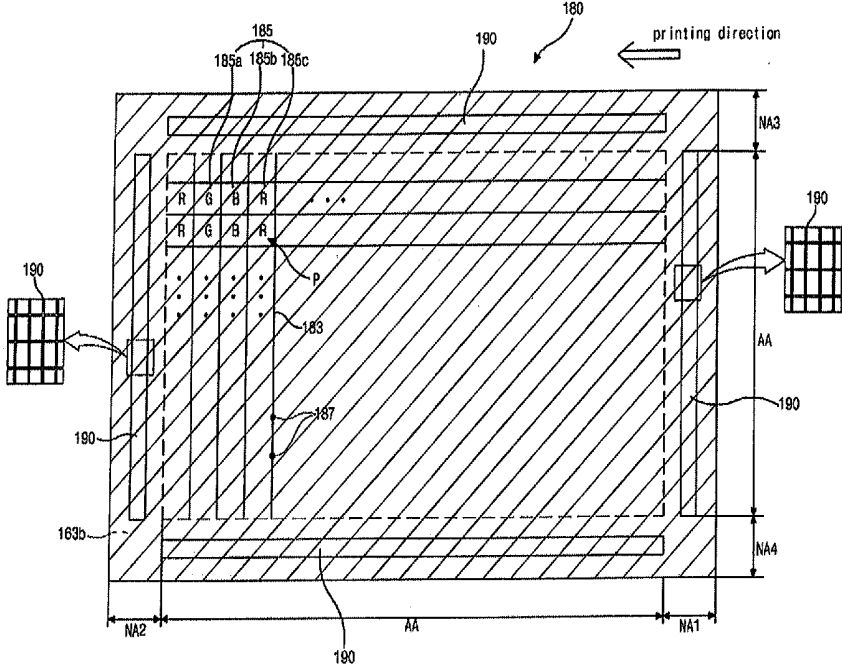
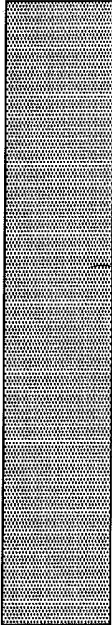

FIG. 5A



170

FIG. 5B

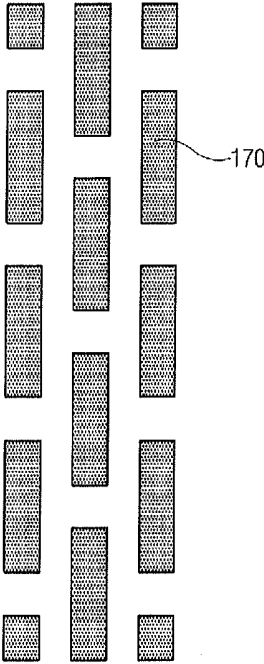

FIG. 5C

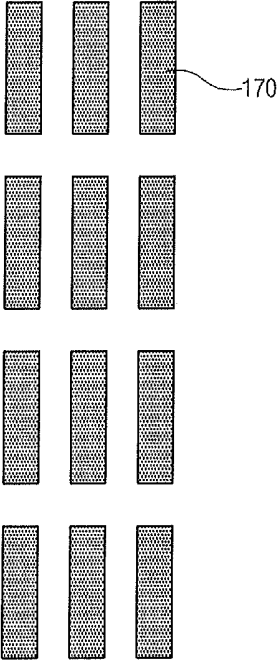

FIG. 5D

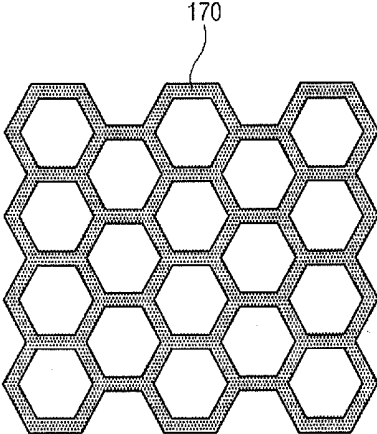

FIG. 5E

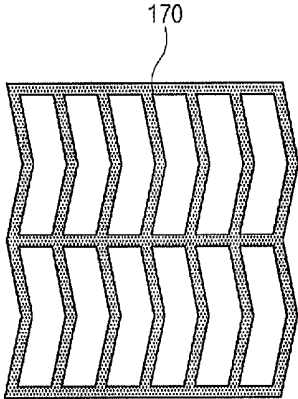

FIG. 5F

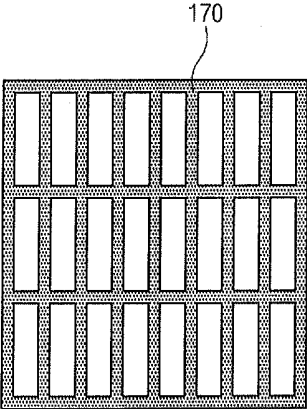

FIG. 5G

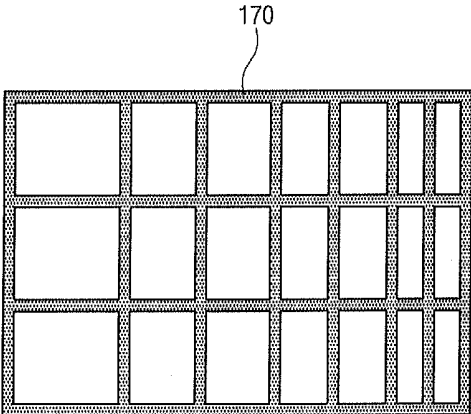

FIG. 6A

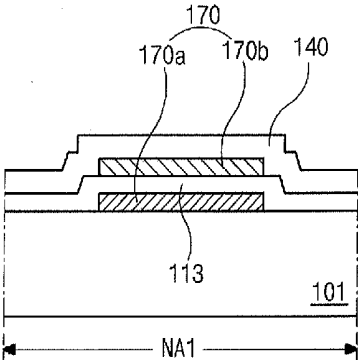

FIG. 6B

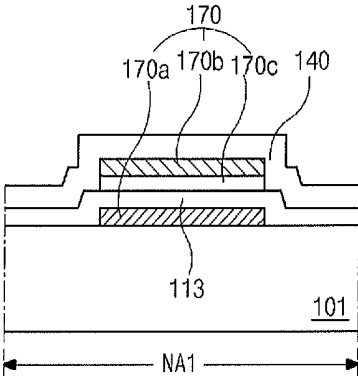

FIG. 6C

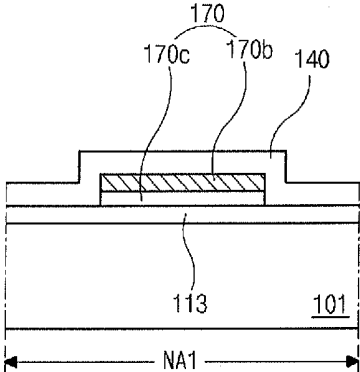

FIG. 6D

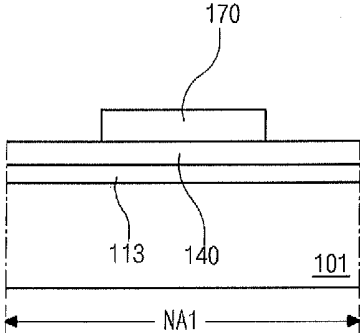

FIG. 7A

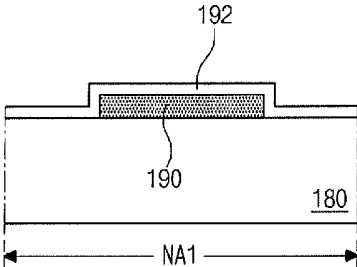
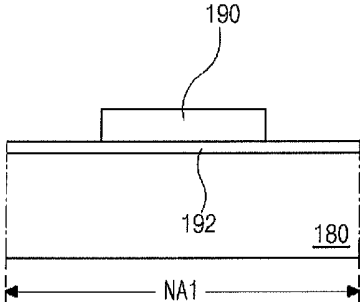

FIG. 7B



SUBSTRATE AND LIQUID CRYSTAL DISPLAY DEVICE INCLUDING THE SAME

PRIORITY CLAIM

[0001] The present patent document is a divisional of U.S. patent application Ser. No. 13/275,991, filed Oct. 18, 2011, which claims priority to Korean Patent Application No. 10-2010-0101313 filed in Korea on Oct. 18, 2010, which are hereby incorporated by reference by their entirety.

BACKGROUND

[0002] 1. Field of the Disclosure

[0003] The present disclosure relates to a liquid crystal display device, and more particularly, to a substrate having a means for preventing a mount of an orientation film and a liquid crystal display device including the substrate.

[0004] 2. Discussion of the Related Art

[0005] Recently, a liquid crystal display (LCD) device has been in the spotlight as a next generation display device having high value added because of its low power consumption and good portability.

[0006] An active matrix liquid crystal display (AM-LCD) device, which includes thin film transistors as a switching device for a plurality of pixels, has been widely used due to its high resolution and superiority in displaying moving images.

[0007] In general, the LCD device is fabricated through an array substrate process for forming a thin film transistor and a pixel electrode on an array substrate, a color filter substrate process for forming a color filter layer and a common electrode on a color filter substrate and a cell process for forming a liquid crystal layer between the array substrate and a color filter substrate.

[0008] FIG. 1 is an exploded perspective view showing a liquid crystal display device according to the related art. In FIG. 1, the liquid crystal display (LCD) device includes an array substrate 10, a color filter substrate 20 and a liquid crystal layer 30 between the array substrate 10 and the color filter substrate 20. The array substrate 10 includes a first substrate 12, a gate line 14 on the first substrate 12, a data line 16 crossing the gate line 14 to define a pixel region P, a thin film transistor (TFT) T connected to the gate line 14 and the data line 16 and a pixel electrode 18 connected to the TFT T.

[0009] In addition, the color filter substrate 20 facing the array substrate 10 includes a second substrate 22, a black matrix 25 blocking a non-display area corresponding to the gate line 14, the data line 16 and the TFT T, a color filter layer 26 including red, green and blue color filters 26a, 26b and 26c each corresponding to the pixel region P and a common electrode 28 on an entire surface of the second substrate 22.

[0010] Although not shown in FIG. 1, a seal pattern may be formed in a boundary portion between the array substrate 10 and the color filter substrate 20 for preventing leakage of the liquid crystal layer 30. A lower orientation film may be formed between the array substrate 10 and the liquid crystal layer 30 and an upper orientation film may be formed between the color filter substrate 20 and the liquid crystal layer 30 for aligning the liquid crystal layer initially. Further, a polarizing plate may be formed on an outer surface of at least one of the first and second substrates 12 and 22.

[0011] A backlight unit may be disposed under the array substrate 10 to supply light. When a gate signal turning on the TFT T is sequentially supplied to the gate line 14, the TFT T is turned on and a data signal supplied to the data line 16 is

applied to the pixel electrode 18 through the TFT T. As a result, a vertical electric field is generated between the pixel electrode 18 and the common electrode 28 and liquid crystal molecules in the liquid crystal layer 30 are re-aligned by the vertical electric field, thereby the LCD device displaying images due to transmittance change of the liquid crystal layer 30.

[0012] The array substrate 10 is fabricated by forming the gate line 14, the data line 16, the TFT T and the pixel electrode 18 on the first substrate 12 through a depositing step, an exposing step, a developing step and an etching step for a source material. The color filter substrate is fabricated by forming the color filter layer 26 and the common electrode 28 on the second substrate 22. In addition, a liquid crystal panel is fabricated by attaching the array substrate 10 and the color filter substrate 20 with the liquid crystal layer 30 interposed therebetween and the LCD device is completed by attaching a driving circuit to the liquid crystal panel.

[0013] Since the LCD device uses an electro-optical effect of the liquid crystal that is determined by anisotropy and arrangement state of the liquid crystal molecules, adjustment of the arrangement state of the liquid crystal molecules influences stabilization in display quality of the LCD device. To obtain a uniform initial arrangement state of the liquid crystal molecules, an orientation process is performed.

[0014] In the orientation process, an orientation film is formed on each of the array substrate and the color filter substrate by printing a polymeric material such as polyimide and the orientation film is rubbed with a rubbing cloth along a predetermined direction. As a result, a polymer chain in the orientation film is aligned along the predetermined direction to have a directivity and the liquid crystal molecules have a uniform initial arrangement state due to the orientation film.

[0015] When the orientation film is formed to have a non-uniform thickness over a display area in the printing step, the orientation film is deteriorated in the subsequent rubbing step. Accordingly, the orientation film is required to have a uniform thickness.

[0016] FIG. 2 is a cross-sectional view showing a printing apparatus of an orientation film according to the related art, and FIG. 3 is a cross-sectional view showing a transferring plate and a substrate in a printing apparatus of an orientation film according to the related art. In FIG. 2, a plate cylinder 51 and a substrate 60 contact each other with a transferring plate 53 interposed therebetween, and a polymeric material is transferred to the substrate 60 by adding a pressure to form an orientation film 63. Since the transferring plate 53 having the polymeric material contacts and is pressurized toward the substrate 60, the polymeric material transferred from the transferring plate 53 to the substrate 60 is spread out toward all directions. Although the orientation film 63 corresponding to a pattern region 54 (of FIG. 3) has a uniform thickness, the orientation film 63 corresponding to an outside of the pattern region 54 has a greater thickness because the orientation film 63 is not pressurized.

[0017] In FIG. 3, the orientation film 63 on the substrate 60 includes a starting portion 63a, an ending portion 63b and a central portion 63c. Due to rotation of the plate cylinder 51 (of FIG. 2), the pattern region 54 of the transferring plate 53 starts contacting the substrate 60 to form the starting portion 63a and stop contacting the substrate 60 to form the ending portion 63b. Since the polymeric material is pushed out from the central portion 63c to the starting and ending portions 63a and 63b, a thickness of each of the starting and ending portions

63a and **63b** is three or four times as great as a thickness of the central portion **63c**. The starting and ending portions **63a** and **63b** may be referred to as a mount of the orientation film **63**.

[0018] The mount causes deterioration of the orientation film **63** in a subsequent rubbing step. In addition, since the starting and ending portions of the orientation film **63** have a zigzag line, the ending portion belonging to the non-display area is designed to have a relatively great width. As a result, a bezel region corresponding to the non-display area is enlarged.

SUMMARY

[0019] A substrate for a liquid crystal display device includes: a substrate including a display region displaying an image and a non-display region surrounding the display region; a dummy pattern in the non-display area over the substrate, the dummy pattern having a length that corresponds to a side of the display area; and an orientation film on the dummy pattern, the orientation film covering the non-display area and the whole display area.

[0020] In another aspect, a liquid crystal display device includes: first and second substrate facing and spaced apart from each other, the first and second substrates including a display region displaying an image and a non-display region surrounding the display region; a gate line and a data line over an inner surface of the first substrate, the gate line and the data line crossing each other to define a pixel region; a thin film transistor connected to the gate line and the data line; a pixel electrode connected to the thin film transistor; a first dummy pattern in the non-display area over the inner surface of the first substrate, the first dummy pattern having a length that corresponds to a side of the display area; a first orientation film on the pixel electrode and the first dummy pattern; a black matrix over an inner surface of the second substrate; a color filter layer in the pixel region, the color filter layer including red, green and blue color filters sequentially repeated in the pixel region; and a plurality of patterned spacers on the color filter layer, the plurality of patterned spacers spaced apart from each other and corresponding to the black matrix; a second dummy pattern in the non-display area over the inner surface of the second substrate, the second dummy pattern having a length that corresponds to the side of the display area; a second orientation film on the plurality of patterned spacers and the second dummy pattern; and a liquid crystal layer between the first and second orientation films.

[0021] It is to be understood that both the foregoing general description and the following detailed description are exemplary and explanatory and are intended to provide further explanation of the invention as claimed.

BRIEF DESCRIPTION OF THE DRAWINGS

[0022] The accompanying drawings, which are included to provide a further understanding of the invention and are incorporated in and constitute a part of this specification, illustrate embodiments of the invention and together with the description serve to explain the principles of the invention. In the drawings:

[0023] FIG. 1 is an exploded perspective view showing a liquid crystal display device according to the related art;

[0024] FIG. 2 is a cross-sectional view showing a printing apparatus of an orientation film according to the related art;

[0025] FIG. 3 is a cross-sectional view showing a transferring plate and a substrate in a printing apparatus of an orientation film according to the related art;

[0026] FIGS. 4A and 4B are plan views showing an array substrate and a color filter substrate, respectively, for a liquid crystal display device according to an embodiment of the present invention;

[0027] FIGS. 5A to 5G are plan views showing a first dummy pattern of a liquid crystal display device according to an embodiment of the present invention;

[0028] FIGS. 6A to 6D are cross-sectional views showing a first dummy pattern of a liquid crystal display device according to an embodiment of the present invention; and

[0029] FIGS. 7A and 7B are cross-sectional views showing a second dummy pattern of a liquid crystal display device according to an embodiment of the present invention.

DETAILED DESCRIPTION OF THE EXEMPLARY EMBODIMENTS

[0030] Reference will now be made in detail to the preferred embodiments, examples of which are illustrated in the accompanying drawings.

[0031] FIGS. 4A and 4B are plan views showing an array substrate and a color filter substrate, respectively, for a liquid crystal display device according to an embodiment of the present invention.

[0032] In FIG. 4A, an array substrate **101** for a liquid crystal display (LCD) device includes a display area **AA** displaying an image and first to fourth non-display areas **NA1**, **NA2**, **NA3** and **NA4** surrounding the display area **AA**. The first to fourth non-display areas **NA1**, **NA2**, **NA3** and **NA4** include first and second pad areas **PA1** and **PA2** where gate and data pads **112** and **137** are respectively formed.

[0033] A gate line **110** and a data line **130** that cross each other to define a pixel region **P** are formed in the display area **AA**. A thin film transistor (TFT) **Tr** connected to the gate line **110** and the data line **130** is formed in the pixel region **P**. Although not shown, the TFT **Tr** may include a gate electrode, a gate insulating layer, a semiconductor layer, a source electrode and a drain electrode. The gate electrode is connected to the gate line **110**. The gate insulating layer is formed on the gate electrode, and the semiconductor layer is formed on the gate insulating layer over the gate electrode. The semiconductor layer may include an active layer of intrinsic amorphous silicon and an ohmic contact layer of impurity-doped amorphous silicon. The source and drain electrodes are formed on the semiconductor layer and are spaced apart from each other. The source electrode is connected to the data line **130**. In addition, a passivation layer is formed on the TFT **Tr**.

[0034] A pixel electrode **150** connected to the drain electrode of the TFT **Tr** is formed in the pixel region **P**. A common electrode may be formed in the pixel region **P** on the array substrate **101** according to a mode of the LCD device. For example, the pixel electrode **150** of a plate shape may be formed in the pixel region **P** on the array substrate **101** when the LCD device has a twisted nematic (TN) mode where a liquid crystal layer is driven by a vertical electric field. In addition, the pixel electrode and the common electrode that have a bar shape and alternate with each other may be formed in the pixel region **P** on the array substrate when the LCD device has an in-plane switching (IPS) mode where the liquid crystal layer is driven by a horizontal electric field. Further, a common line parallel to and spaced apart from the gate line

110 may be formed on the array substrate **101** and the common electrode may be connected to the common line.

[0035] The gate pad **112** in the first pad area **PA1** is connected to the gate line **110** and the data pad **137** in the second pad area **PA2** is connected to the data line **130**. In addition, a first dummy pattern **170** is formed in at least one of the first to fourth non-display area **NA1**, **NA2**, **NA3** and **NA4** on the array substrate **101**. The first dummy pattern **170** may have a length corresponding to a side of the display area **AA**.

[0036] FIGS. **5A** to **5G** are plan views showing a first dummy pattern of a liquid crystal display device according to an embodiment of the present invention.

[0037] The first dummy pattern **170** may have a single bar pattern (dam shape) as shown in FIG. **5A**. In addition, the first dummy pattern **170** may have a plurality of bar patterns spaced apart from each other as shown in FIGS. **5B** and **5C**. In FIG. **5B**, the plurality of bar patterns are alternately disposed with each other such that ends of the adjacent bar patterns are not flush with each other. In FIG. **5C**, the plurality of bar patterns are disposed such that ends of the adjacent bar patterns are flush with each other. Although the adjacent bar patterns are spaced apart from each other by an equal distance in FIGS. **5B** and **5C**, the adjacent bar patterns may be spaced apart from each other by a gradually increasing or decreasing distance in another embodiment.

[0038] Further, the first dummy pattern **170** may have a lattice pattern as shown in FIGS. **5D** to **5G**. For example, the lattice pattern may include an opening having one of a hexagonal shape, a bent rectangular shape and a rectangular shape. In FIGS. **5D** to **5F**, the opening of the lattice pattern has an equal size (area). In FIG. **5E**, the opening of the lattice pattern has a gradually increasing or decreasing size (area).

[0039] Referring again to FIG. **4A**, the first dummy pattern **170** may have a height of about $0.5\ \mu\text{m}$ to about $3\ \mu\text{m}$ and a width of about $20\ \mu\text{m}$ to about $200\ \mu\text{m}$. For example, the first dummy pattern **170** may have a width of about $50\ \mu\text{m}$ to about $200\ \mu\text{m}$ when the first dummy pattern **170** has the single bar pattern as shown in FIG. **5A**. In addition, the first dummy pattern **170** may have a width of about $20\ \mu\text{m}$ to about $50\ \mu\text{m}$ when the first dummy pattern **170** has one of the plurality of bar patterns as shown in FIGS. **5B** and **5C** and the lattice pattern as shown in FIGS. **5D** to **5G**.

[0040] The height of the first dummy pattern **170** may vary with a position of the first dummy pattern **170**. As the height of the first dummy pattern **170** increases, a thickness of the orientation film decreases. Accordingly, a mount of the orientation film is prevented by adjusting the height of the first dummy pattern **170**. For example, when the printing step for an orientation film starts at the first non-display area **NA1** and ends at the second non-display area **NA2**, a first height of the first dummy pattern **170** in the first non-display area **NA1** may be smaller than a second height of the first dummy pattern **170** in the second non-display area **NA2**.

[0041] In addition, when the first dummy pattern **170** has one of the plurality of bar patterns as shown in FIGS. **5B** and **5C** and the lattice pattern as shown in FIGS. **5D** to **5G**, the distance between the adjacent bar patterns or the size (area) of the opening of the lattice pattern (i.e., lattice density) may vary with a position of the first dummy pattern **170**. As the distance between the adjacent bar patterns or the size of the opening increases, a thickness of the orientation film decreases. Accordingly, a mount of the orientation film is prevented by adjusting the distance between adjacent bar patterns or the size of the opening of the lattice pattern of the

first dummy pattern **170**. For example, when the printing step for an orientation film starts at the first non-display area **NA1** and ends at the second non-display area **NA2**, a first distance between the adjacent bar patterns of the first dummy pattern **170** in the first non-display area **NA1** may be smaller than a second distance between the adjacent bar patterns of the first dummy pattern **170** in the second non-display area **NA2** for the first dummy pattern **170** of the plurality of bar patterns as shown in FIGS. **5B** and **5C**. In addition, a first size (area) of the opening of the lattice pattern of the first dummy pattern **170** in the first non-display area **NA1** may be smaller than a second size (area) of the opening of the lattice pattern of the first dummy pattern **170** in the second non-display area **NA2** for the first dummy pattern **170** having the lattice pattern as shown in FIGS. **5D** to **5G**.

[0042] The first dummy pattern **170** may be formed of a multiple layer used for fabricating the array substrate **101**. FIGS. **6A** to **6D** are cross-sectional views showing a first dummy pattern of a liquid crystal display device according to an embodiment of the present invention.

[0043] In FIGS. **4A** and **6A**, the first dummy pattern **170** in the first and fourth non-display areas **NA1** and **NA4** may have a double-layered structure including a gate dummy layer **170a** and a data dummy layer **170b** over the array substrate **101**. Since the first and fourth non-display areas **NA1** and **NA4** do not include the first and second pad areas **PA1** and **PA2**, the gate dummy layer **170a** may include the same layer and the same material as the gate line **110** and the data dummy layer **170b** may include the same layer and the same material as the data line **130**. In addition, the first dummy pattern **170** may have at least one of the single bar pattern, a plurality of bar patterns and the lattice pattern as shown in FIGS. **5A** to **5G**. For example, the gate dummy layer **170a** and the data dummy layer **170b** may overlap each other with the same shape and the same area as each other. In addition, the gate dummy layer **170a** may be formed on the array substrate **101**, a gate insulating layer **113** may be formed between the gate dummy layer **170a** and the data dummy layer **170b**, and a passivation layer **140** may be formed on the data dummy layer **170b**.

[0044] In FIGS. **4A** and **6B**, the first dummy pattern **170** in the first and fourth non-display areas **NA1** and **NA4** may have a triple-layered structure including a gate dummy layer **170a**, a semiconductor dummy layer **170c** and a data dummy layer **170b** over the array substrate **101**. Since the first and fourth non-display areas **NA1** and **NA4** do not include the first and second pad areas **PA1** and **PA2**, the gate dummy layer **170a** may include the same layer and the same material as the gate line **110**, the semiconductor dummy layer **170c** may include the same layer and the same material as the semiconductor layer, and the data dummy layer **170b** may include the same layer and the same material as the data line **130**. In addition, the first dummy pattern **170** may have at least one of the single bar pattern, a plurality of bar patterns and the lattice pattern as shown in FIGS. **5A** to **5G**. For example, the gate dummy layer **170a**, the semiconductor dummy layer **170c** and the data dummy layer **170b** may overlap each other with the same shape and the same area as each other. Further, the gate dummy layer **170a** may be formed on the array substrate **101**, and a gate insulating layer **113** may be formed between the gate dummy layer **170a** and the semiconductor dummy layer **170c**. Moreover, the data dummy layer **170b** may be formed on the semiconductor dummy layer **170c**, and a passivation layer **140** may be formed on the data dummy layer **170b**.

[0045] In FIGS. 4A and 6C, the first dummy pattern 170 in the second non-display areas NA2 may be disposed between the first pad area PA1 and the display area AA and may have a double-layered structure including a semiconductor dummy layer 170c and a data dummy layer 170b over the array substrate 101. Since the second non-display areas NA2 includes the first pad area PA1, the semiconductor dummy layer 170c may include the same layer and the same material as the semiconductor layer and the data dummy layer 170b may include the same layer and the same material as the data line 130. In addition, the first dummy pattern 170 may have at least one of the single bar pattern, a plurality of bar patterns and the lattice pattern as shown in FIGS. 5A to 5G. For example, the semiconductor dummy layer 170c and the data dummy layer 170b may overlap each other with the same shape and the same area as each other. Further, the semiconductor dummy layer 170c and the data dummy layer 170b may be sequentially formed on a gate insulating layer 113, and a passivation layer 140 may be formed on the data dummy layer 170b.

[0046] Alternatively, the first dummy pattern 170 in the second non-display areas NA2 may be disposed between the first pad area PA1 and the display area AA and may have a triple-layered structure including a gate dummy layer 170a, a semiconductor dummy layer 170c and a data dummy layer 170b over the array substrate 101. Since the second non-display areas NA2 includes the first pad area PA1, the first dummy pattern 170 may have a plurality of bar patterns as shown in FIG. 5C such that the gate line 110 is disposed between adjacent bar patterns. For example, the gate dummy layer 170a, the semiconductor dummy layer 170c and the data dummy layer 170b may overlap each other with the same shape and the same area as each other. Further, the gate dummy layer 170a may include the same layer and the same material as the gate line 110, the semiconductor dummy layer 170c may include the same layer and the same material as the semiconductor layer, and the data dummy layer 170b may include the same layer and the same material as the data line 130.

[0047] Similarly, the first dummy pattern 170 in the third non-display areas NA3 may be disposed between the second pad area PA2 and the display area AA and may have a double-layered structure including a gate dummy layer 170a and a semiconductor dummy layer 170c over the array substrate 101 and may have at least one of the single bar pattern, a plurality of bar patterns and the lattice pattern as shown in FIGS. 5A to 5G. Alternatively, the first dummy pattern 170 in the third non-display areas NA3 may be disposed between the second pad area PA2 and the display area AA and may have a triple-layered structure including a gate dummy layer 170a, a semiconductor dummy layer 170c and a data dummy layer 170b over the array substrate 101 and may have a plurality of bar patterns as shown in FIG. 5C.

[0048] When the first dummy pattern 170 has one of a plurality of bar patterns as shown in FIGS. 5C and 5C and a lattice pattern as shown in FIGS. 5D to 5G, a distance between the adjacent bar patterns or a shape of an opening of the lattice pattern may be adjusted according to a position of the first dummy pattern 170. In addition, a height of the first dummy pattern 170 may be adjusted by omitting at least one of the gate dummy layer 170a, the semiconductor dummy layer 170c and the data dummy layer 170b.

[0049] The first dummy pattern 170 causes a step difference in the passivation layer 140 and the step difference of the

passivation layer 140 prevents a mount of the orientation film and a zigzag line of the ending and starting portions of the orientation film. As a result, a bezel region of the LCD device is reduced.

[0050] Although the first dummy pattern 170 in the first to fourth non-display areas NA1, NA2, NA3 and NA4 is formed of the layers used for the TFT Tr (of FIG. 4A) of the array substrate 101 in FIGS. 6A to 6C, the first dummy pattern 170 may be formed of an organic material as shown in FIG. 6D. For example, the first dummy pattern 170 in the first to fourth non-display areas NA1, NA2, NA3 and NA4 may be formed on a passivation layer 140 by coating and patterning an organic material such as acrylic resin and benzocyclobutene (BCB),

[0051] In FIG. 4B, a color filter substrate 180 for the LCD device also includes the display area AA and the first to fourth non-display areas NA1, NA2, NA3 and NA4 surrounding the display area AA. A black matrix 183 is formed along a boundary of the pixel region P in the display area AA and a color filter layer 185 is formed in the pixel region P exposed through the black matrix 183. The color filter layer 185 includes red, green and blue color filters 185a, 185b and 185c sequentially repeated in the pixel regions P.

[0052] Although not shown, a common electrode may be formed on the color filter substrate 180 according to a mode of the LCD device. For example, the common electrode and an overcoat layer may be sequentially formed on an entire surface of the color filter layer 185 and the pixel electrode 150 (of FIG. 4A) may be formed in the pixel region P on the array substrate 101 (of FIG. 4A) when the LCD device has a TN mode. In addition, an overcoat layer may be formed on an entire surface of the color filter layer 185 and the pixel electrode and the common electrode of a bar shape may be formed in the pixel region P on the array substrate 101 when the LCD device has an IPS mode. The overcoat layer may be omitted. A plurality of patterned spacers for maintaining a uniform cell gap may be formed on one of the common electrode and the overcoat layer. The plurality of patterned spacers may be spaced apart from each other to correspond to the black matrix 183.

[0053] A second dummy pattern 190 is formed in at least one of first to fourth non-display areas NA1, NA2, NA3 and NA4 on the color filter substrate 180. The second dummy pattern 190 may have a length corresponding to a side of the display area AA. In addition, the second dummy pattern 190 may have a height of about 0.5 μm to about 3 μm and a width of about 20 μm to about 200 μm . In addition, the second dummy pattern 190 may have at least one of the single bar pattern similarly to FIG. 5A, the plurality of bar patterns similarly to FIGS. 5B and 5C and the lattice pattern similarly to FIGS. 5D to 5G.

[0054] FIGS. 7A and 7B are cross-sectional views showing a second dummy pattern of a liquid crystal display device according to an embodiment of the present invention.

[0055] In FIGS. 4B and 7A, the second dummy pattern 190 in the first to fourth non-display areas NA1, NA2, NA3 and NA4 may have a single-layered structure over the color filter substrate 180. The second dummy pattern 190 may include the same layer and the same material as the black matrix 183 and the common electrode 192 may be formed on the second dummy pattern 190. The second dummy pattern 190 causes a step difference in the common electrode 192 and the step difference of the common electrode 192 prevents a mount of

the orientation film and a zigzag line of the ending portion of the orientation film. As a result, a bezel region of the LCD device is reduced.

[0056] In FIGS. 4B and 7B, the second dummy pattern 190 in the first to fourth non-display areas NA1, NA2, NA3 and NA4 may have a single-layered structure over the color filter substrate 180. The second dummy pattern 190 may include the same layer and the same material as the patterned spacer and may be formed on one of the common electrode 192 and the overcoat layer. The second dummy pattern 190 generates a step difference that prevents a mount of the orientation film and a zigzag line of the ending and starting portions of the orientation film. As a result, a bezel region of the LCD device is reduced.

[0057] Although not shown, an orientation film is formed on each of the array substrate 101 and the color filter substrate 180 by printing a polymeric material such as polyimide and the orientation film is rubbed with a rubbing cloth without generation of a mount of the orientation film due to the first and second dummy patterns 170 and 190. The array substrate 101 and the color filter substrate 180 having the orientation film are attached with a liquid crystal layer interposed therebetween by a seal pattern to complete the LCD device.

[0058] Consequently, in an LCD device according to the present disclosure, a dummy pattern that prevents a mount of an orientation film is formed in a non-display area surrounding a display area. As a result, a mount having a relatively great thickness at starting and ending portions of the orientation film is prevented. Since the mount of the orientation film is prevented, deterioration in a rubbing step is prevented. In addition, lifting of the orientation film due to contact with a seal pattern is prevented. Further, since the starting and ending portions of the orientation film have a straight line instead of a zigzag line due to the dummy pattern, a margin for an alignment error and a bezel region are reduced and the LCD device obtains a narrow bezel.

[0059] It will be apparent to those skilled in the art that various modifications and variations can be made in a substrate and a liquid crystal display device including the substrate of the present disclosure without departing from the spirit or scope of the invention. Thus, it is intended that the present invention covers the modifications and variations of this invention provided they come within the scope of the appended claims and their equivalents.

What is claimed is:

1. A liquid crystal display device, comprising:

first and second substrate facing and spaced apart from each other, the first and second substrates including a display region displaying an image and a non-display region surrounding the display region;

a gate line and a data line over an inner surface of the first substrate, the gate line and the data line crossing each other to define a pixel region;

a thin film transistor connected to the gate line and the data line;

a pixel electrode connected to the thin film transistor;

a first dummy pattern in the non-display area over the inner surface of the first substrate, the first dummy pattern having a length that corresponds to a side of the display area;

a first orientation film on the pixel electrode and the first dummy pattern;

a black matrix over an inner surface of the second substrate;

a color filter layer in the pixel region, the color filter layer including red, green and blue color filters sequentially repeated in the pixel region; and

a plurality of patterned spacers on the color filter layer, the plurality of patterned spacers spaced apart from each other and corresponding to the black matrix;

a second dummy pattern in the non-display area over the inner surface of the second substrate, the second dummy pattern having a length that corresponds to the side of the display area;

a second orientation film on the plurality of patterned spacers and the second dummy pattern; and

a liquid crystal layer between the first and second orientation films.

2. The device according to claim 1, wherein each of the first and second dummy patterns has at least one of a single bar pattern, a plurality of bar patterns spaced apart from each other and a lattice pattern including an opening that has one of a hexagonal shape, a bent rectangular shape and a rectangular shape.

3. The device according to claim 2, wherein each of the first and second dummy patterns has one of the plurality of bar patterns and the lattice pattern including the opening, and wherein a distance between the adjacent bar patterns varies with a position of each of the first and second dummy patterns and an area of the opening varies with a position of each of the first and second dummy patterns.

4. The device according to claim 2, wherein the adjacent bar patterns are spaced apart from each other by one of a gradually increasing distance and a gradually decreasing distance, and the opening has one of a gradually increasing area and a gradually decreasing area.

5. The device according to claim 2, wherein each of the first and second dummy patterns has one of the plurality of bar patterns that are alternately disposed with each other and the plurality of bar patterns whose ends are flush with each other.

* * * * *

专利名称(译)	基板和包括其的液晶显示装置		
公开(公告)号	US20150226989A1	公开(公告)日	2015-08-13
申请号	US14/690775	申请日	2015-04-20
[标]申请(专利权)人(译)	乐金显示有限公司		
申请(专利权)人(译)	LG DISPLAY CO. , LTD.		
当前申请(专利权)人(译)	LG DISPLAY CO. , LTD.		
[标]发明人	LEE JAE WON NOH SO YOUNG KIM SUNG KI KIM JIN PIL SON KYUNG MO		
发明人	LEE, JAE-WON NOH, SO-YOUNG KIM, SUNG-KI KIM, JIN-PIL SON, KYUNG-MO		
IPC分类号	G02F1/1337 G02F1/1339 G02F1/1335 G02F1/1368 G02F1/1362		
CPC分类号	G02F1/1337 G02F1/1368 G02F1/1339 G02F1/133512 G02F1/133514 G02F1/136286 G02F1/133784 G02F1/13394 G02F2001/133388 G02F2001/13396		
优先权	1020100101313 2010-10-18 KR		
其他公开文献	US9891476		
外部链接	Espacenet USPTO		

摘要(译)

一种用于液晶显示装置的基板，包括：基板，包括显示图像的显示区域和围绕显示区域的非显示区域；在基板上方的非显示区域中的虚设图案，虚设图案具有与显示区域的一侧相对应的长度；虚设图案上的取向膜，取向膜覆盖非显示区域和整个显示区域。

