



US 20140204073A1

(19) **United States**  
(12) **Patent Application Publication**  
**Toyotaka et al.**

(10) **Pub. No.: US 2014/0204073 A1**  
(43) **Pub. Date: Jul. 24, 2014**

(54) **LIQUID CRYSTAL DISPLAY DEVICE AND DRIVING METHOD OF THE SAME**

**Publication Classification**

(71) Applicant: **Semiconductor Energy Laboratory Co., Ltd.**, Atsugi-shi (JP)

(51) **Int. Cl.**  
**G09G 3/36** (2006.01)

(72) Inventors: **Kouhei Toyotaka**, Atsugi (JP); **Hiroyuki Miyake**, Atsugi (JP); **Ryo Arasawa**, Isehara (JP); **Koji Kusunoki**, Atsugi (JP); **Tsutomu Murakawa**, Isehara (JP)

(52) **U.S. Cl.**  
CPC ..... **G09G 3/3648** (2013.01)  
USPC ..... **345/212; 345/98**

(73) Assignee: **Semiconductor Energy Laboratory Co., Ltd.**, Atsugi-shi (JP)

(57) **ABSTRACT**

(21) Appl. No.: **14/219,275**

Provided is a liquid crystal display device having a pixel including a transistor and a liquid crystal element and a protection circuit electrically connected to one of a source and a drain of the transistor through a data line. The protection circuit includes a first terminal supplied with a first power supply potential and a second terminal supplied with a second power supply potential higher than the first power supply potential. In a moving image display mode, an image signal is input from the data line to the liquid crystal element through the transistor, and the first power supply potential is set at the first potential. In a still image display mode, supply of the image signal is stopped, and the first power supply potential is set at the second potential. The second potential is substantially the same as the minimum value of the image signal.

(22) Filed: **Mar. 19, 2014**

**Related U.S. Application Data**

(63) Continuation of application No. 13/193,981, filed on Jul. 29, 2011, now Pat. No. 8,692,823.

(30) **Foreign Application Priority Data**

Aug. 6, 2010 (JP) ..... 2010-178132

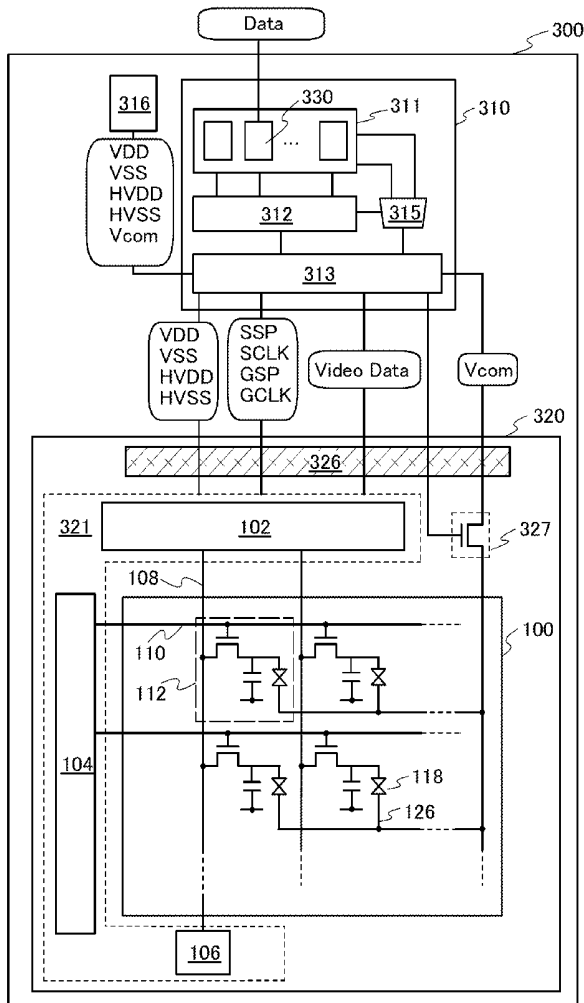



FIG. 2

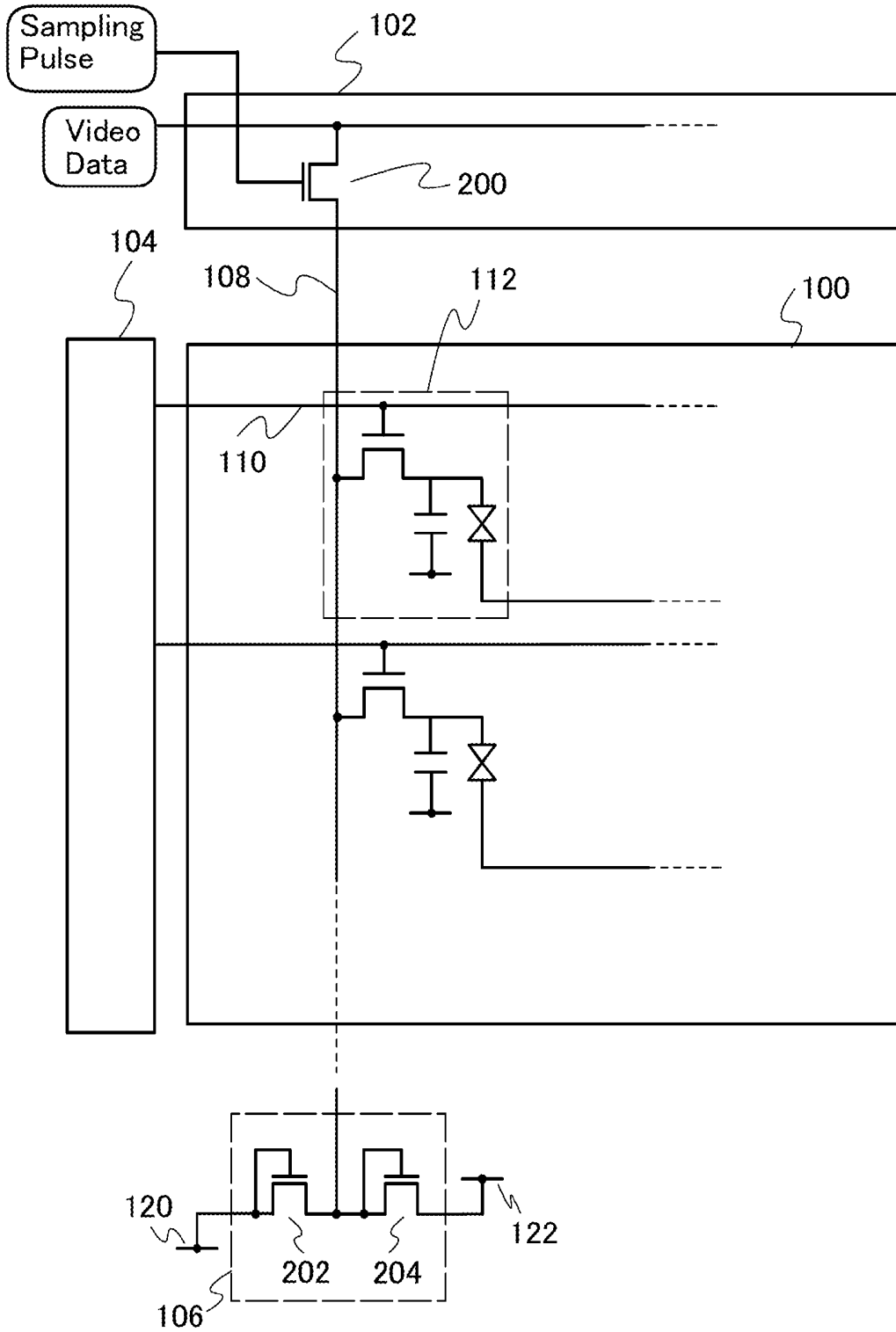

FIG. 3

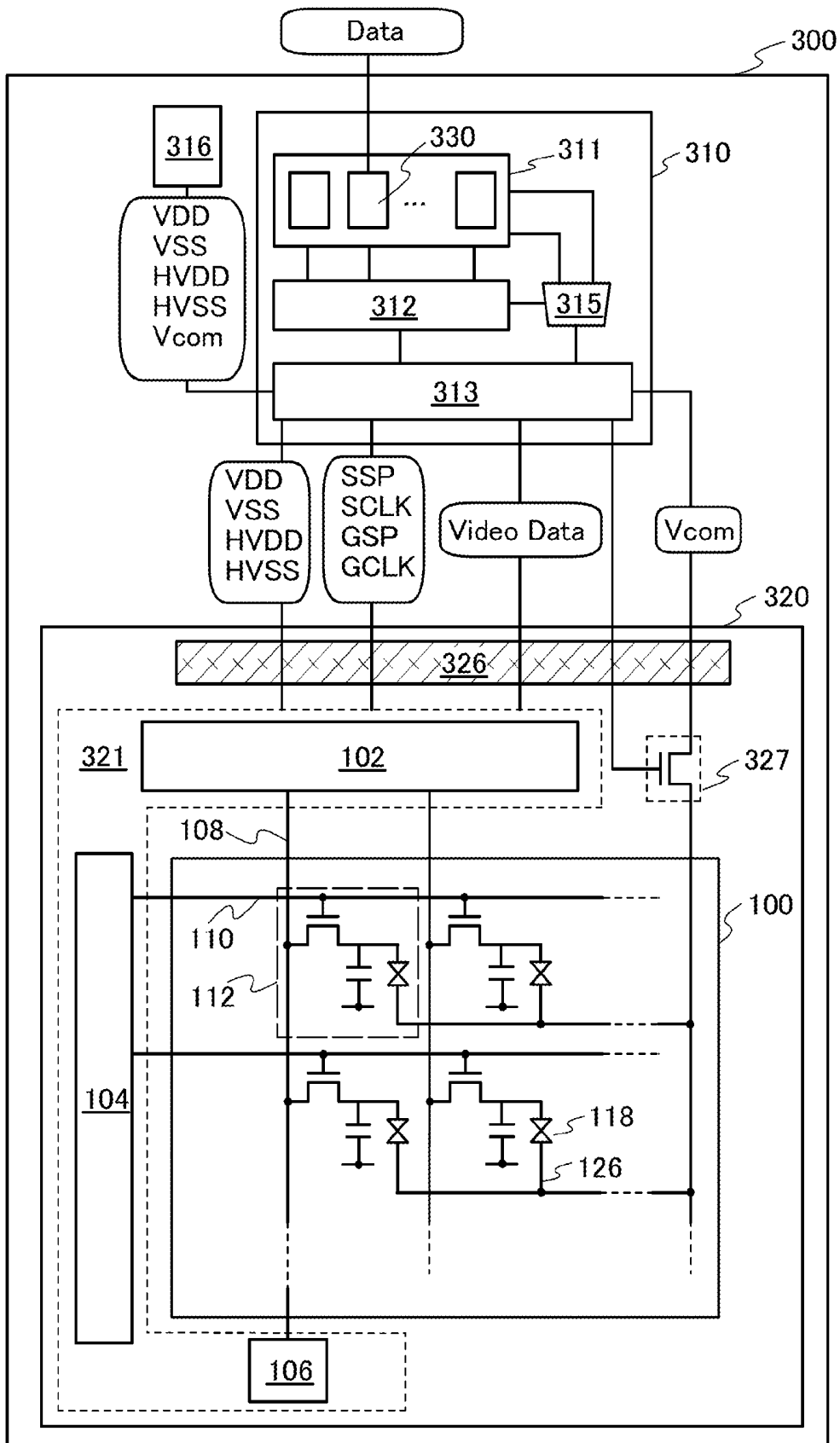

FIG. 4

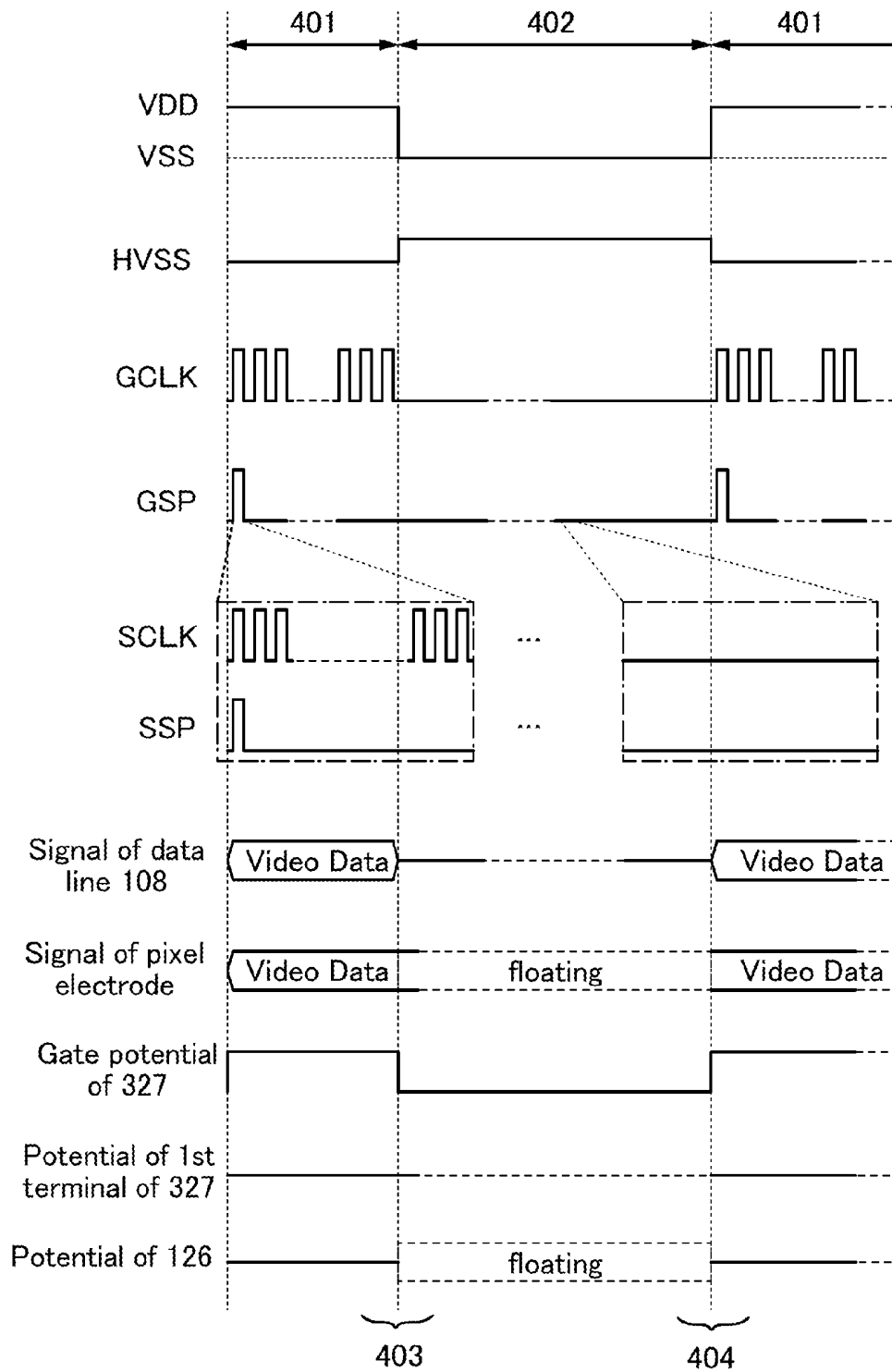

FIG. 5A

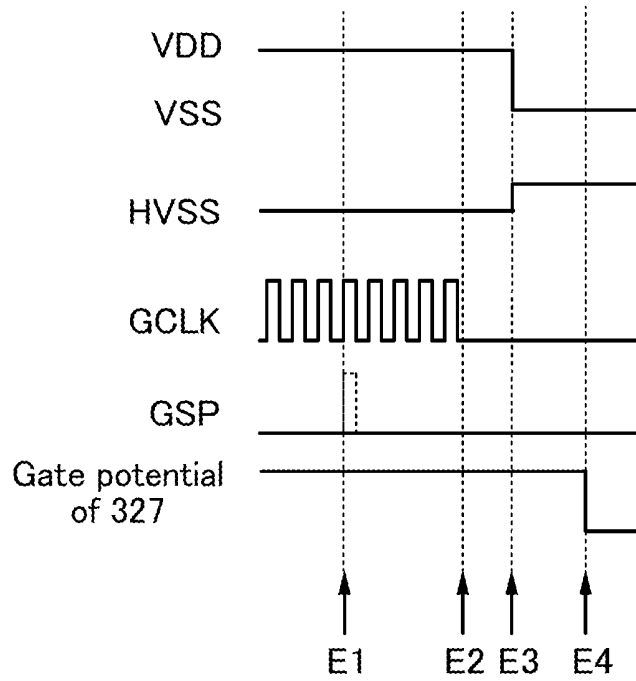

FIG. 5B

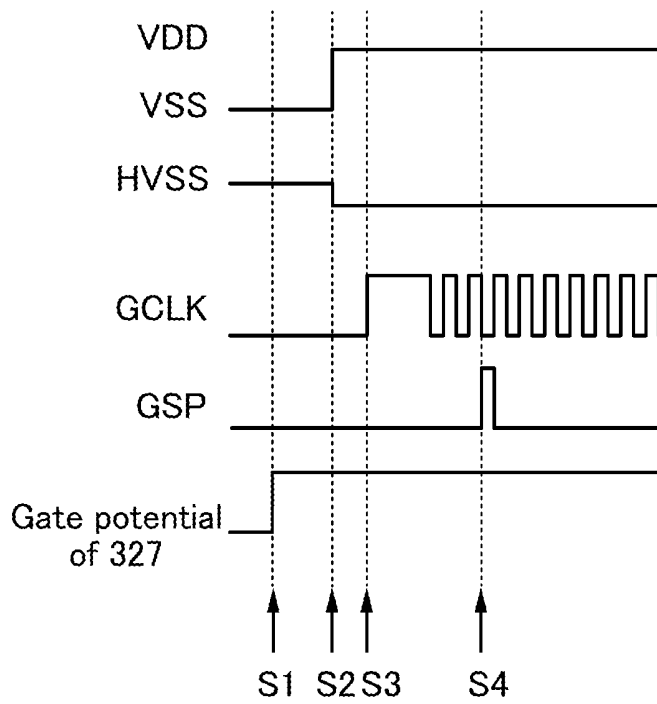

FIG. 6

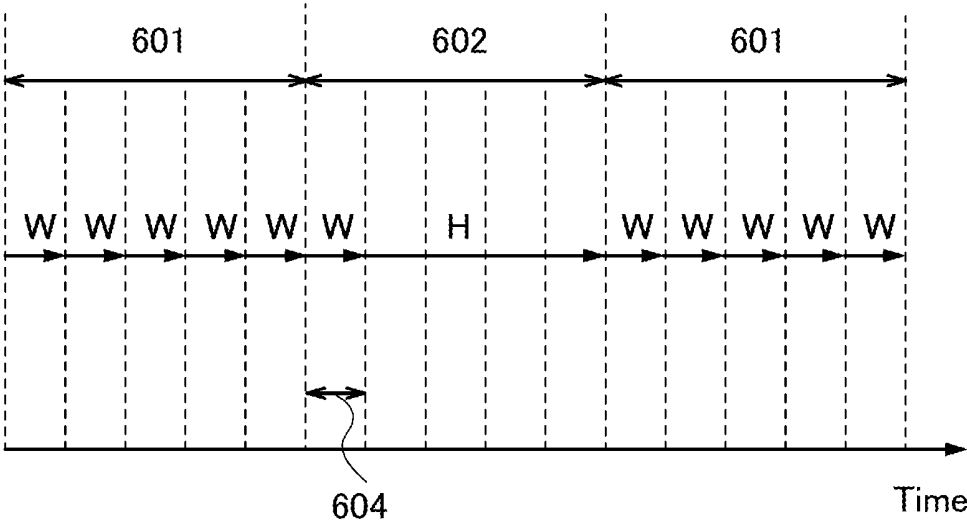

FIG. 7A

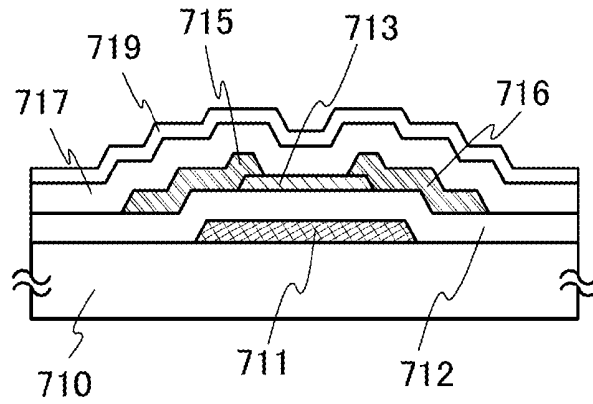

FIG. 7B

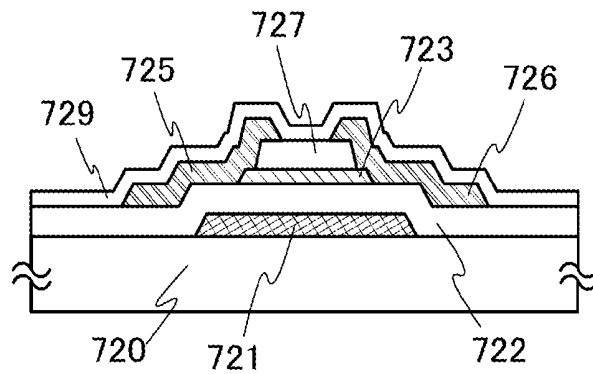

FIG. 7C

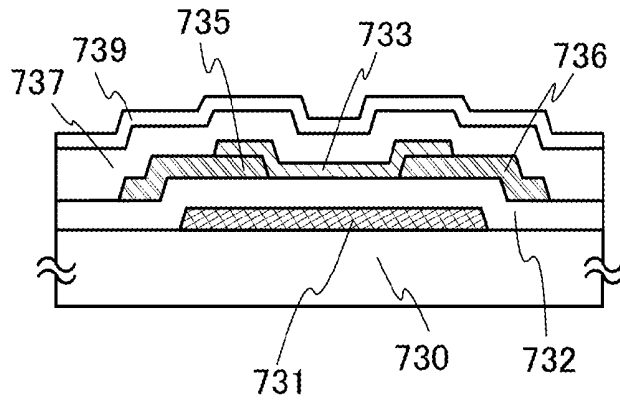

FIG. 7D

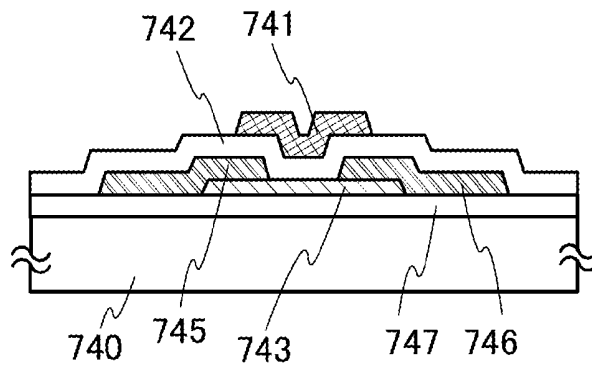

FIG. 8A

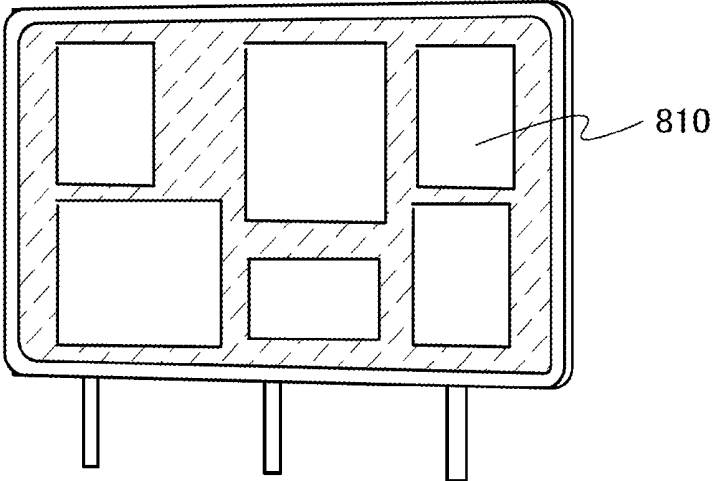

FIG. 8B

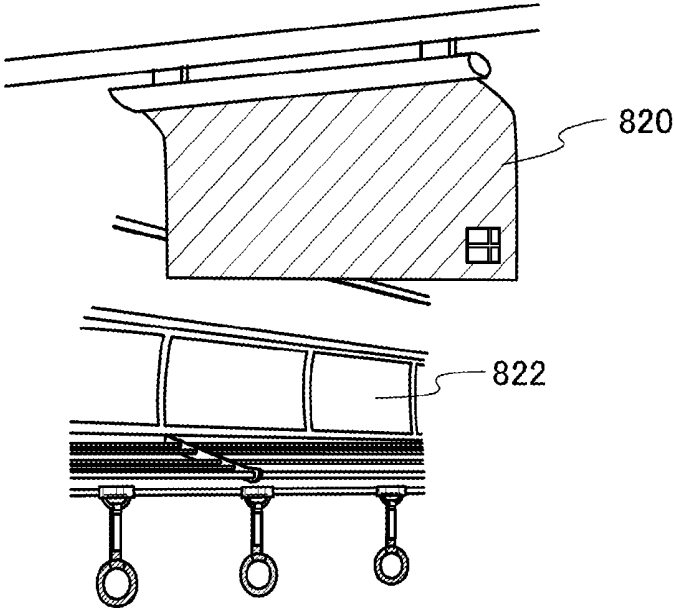

FIG. 9

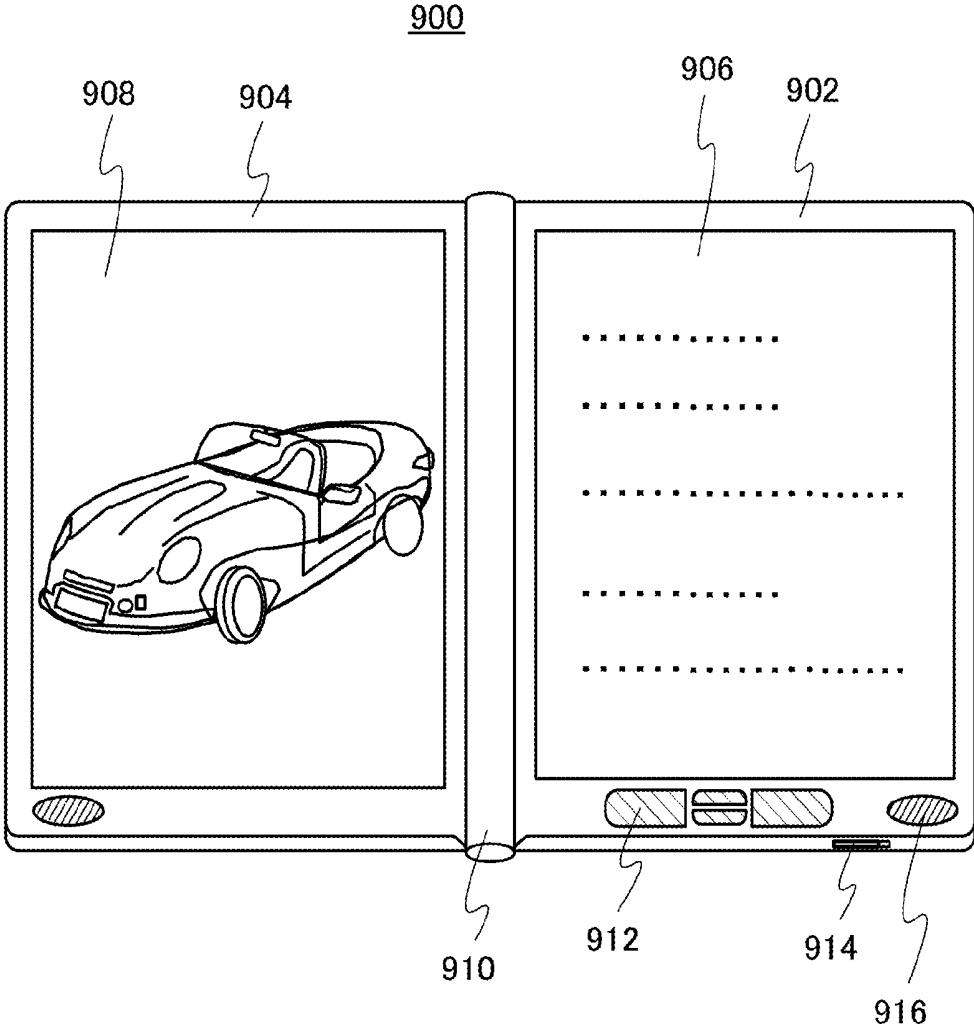

FIG. 10A

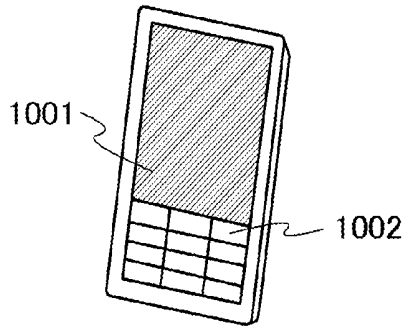

FIG. 10B

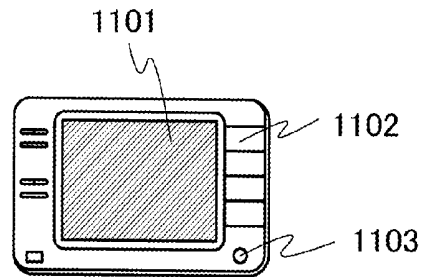

FIG. 10C

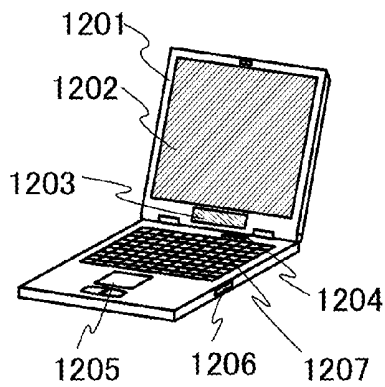

FIG. 10D

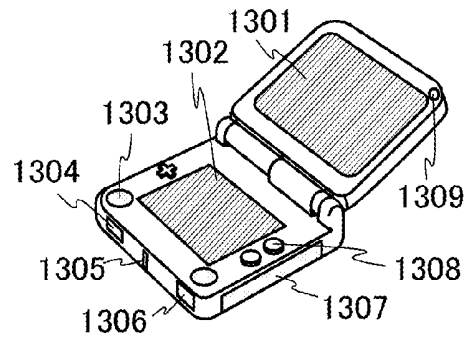

FIG. 10E

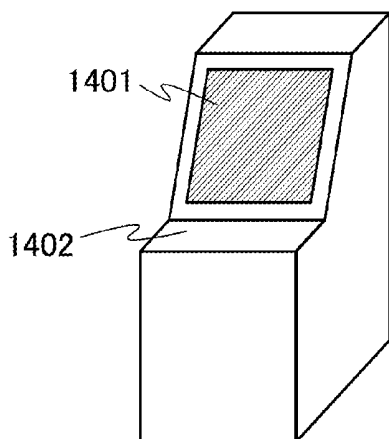

FIG. 10F

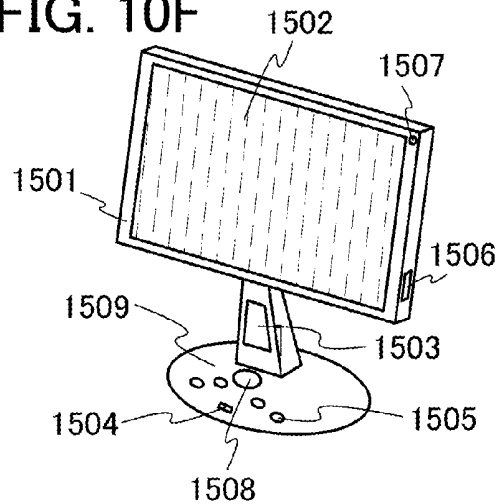

FIG. 11A

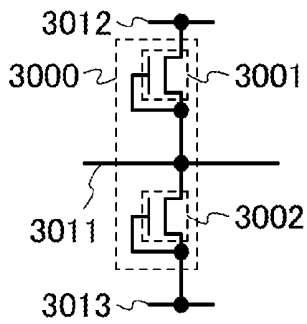

FIG. 11B

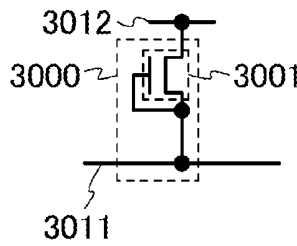

FIG. 11C

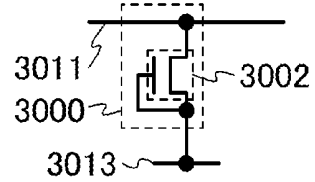

FIG. 11D

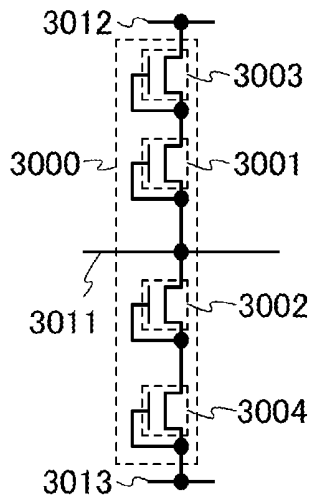

FIG. 11E

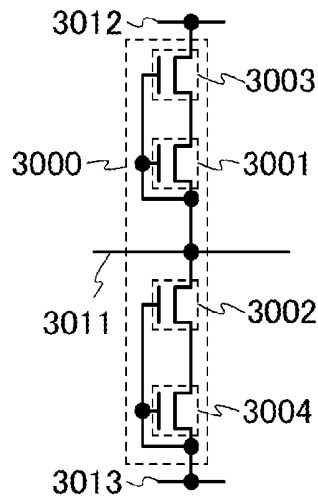

FIG. 11F

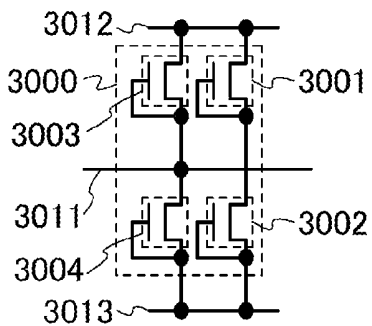

FIG. 11G

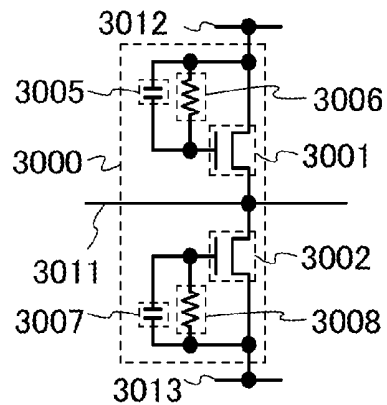

FIG. 12A

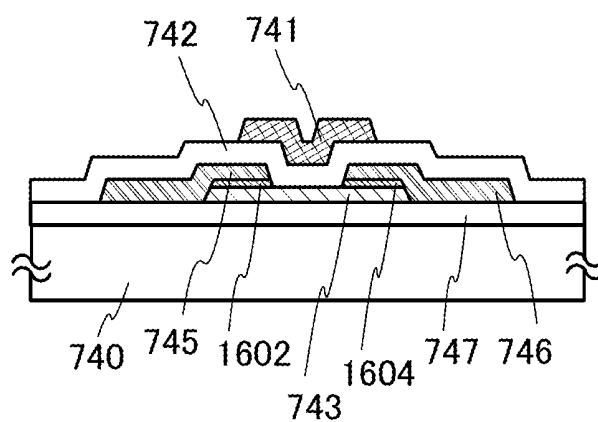

FIG. 12B

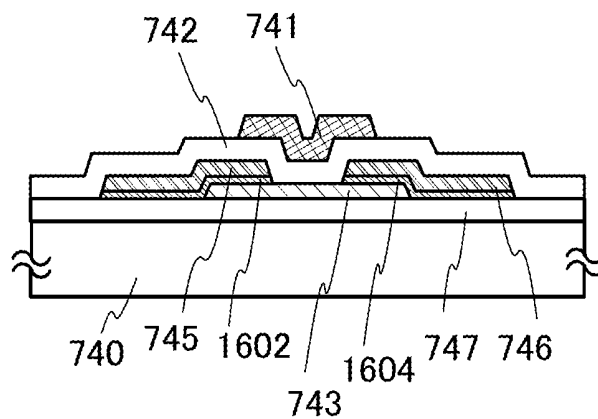

FIG. 13A

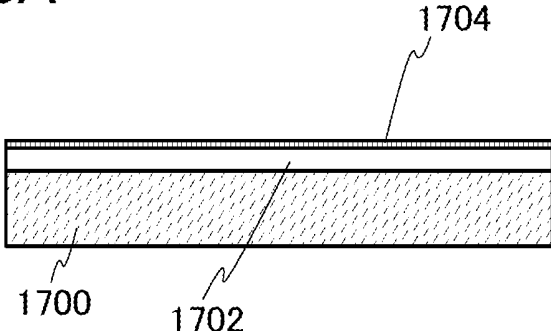

FIG. 13B

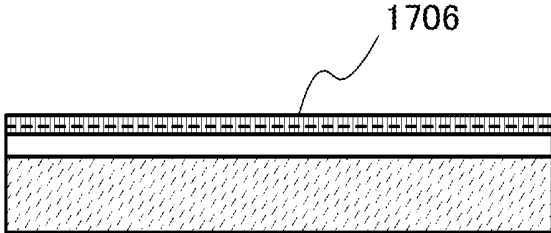
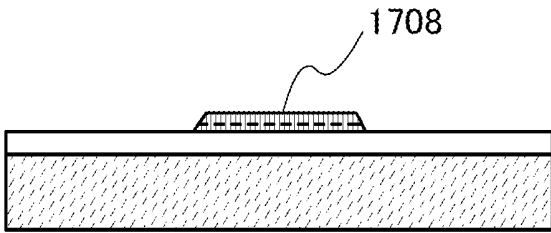

FIG. 13C



## LIQUID CRYSTAL DISPLAY DEVICE AND DRIVING METHOD OF THE SAME

### CROSS-REFERENCE TO RELATED APPLICATIONS

[0001] This application is a continuation of U.S. application Ser. No. 13/193,981, filed Jul. 29, 2011, now allowed, which claims the benefit of a foreign priority application filed in Japan as Serial No. 2010-178132 on Aug. 6, 2010, both of which are incorporated by reference.

### BACKGROUND OF THE INVENTION

[0002] 1. Field of the Invention

[0003] The present invention relates to a liquid crystal display device and the driving method of the liquid crystal display.

[0004] 2. Description of the Related Art

[0005] In recent years, techniques for reducing power consumption in liquid crystal display devices have been developed.

[0006] As a method for reducing power consumption of a liquid crystal display device, a method by which the frequency of writing of an image signal to a pixel during displaying a still image is reduced to be lower than the frequency of writing of an image signal to a pixel during displaying a moving image is given (e.g., Patent Documents 1 and 2). By this method, the frequency of writing of an image signal for displaying a still image is reduced, and power consumption of a liquid crystal display device is reduced.

[0007] In a liquid crystal display device, a protection circuit is often provided for a source line or a gate line in order to prevent electrostatic destruction of a transistor or the like in a pixel due to static electricity, overvoltage caused by malfunction, or the like.

[0008] For example, a liquid crystal display device which includes a protection circuit in which a MOS transistor whose source and gate are short-circuited and a MOS transistor whose gate and drain are short-circuited are connected in series between a scan electrode and a conductive line provided in a periphery of a display portion is known (e.g., Patent Document 3).

### REFERENCES

[0009] [Patent Document 1] Japanese Published Patent Application No. 2005-283775

[0010] [Patent Document 2] Japanese Published Patent Application No. 2002-278523

[0011] [Patent Document 3] Japanese Published Patent Application No. H7-092448

### SUMMARY OF THE INVENTION

[0012] When a transistor is degraded by a long time use, leakage current of the transistor in an off state becomes large in some cases because of change in characteristics such as a shift of the threshold voltage.

[0013] When a transistor is degraded by light such as back-light or external light, leakage current of the transistor in an off state becomes large in some cases because of change in characteristics such as a shift of the threshold voltage.

[0014] In addition, when characteristics, such as the threshold voltage, in transistors included in a plurality of protection circuits vary, the protection circuits may include a transistor having large leakage current in the off state.

[0015] An object of an embodiment of the present invention is to stably display an image in a liquid crystal display device in which moving image display and still image display are switched, even in the case where change in characteristics such as a shift of threshold voltage of a transistor of a protection circuit is caused.

[0016] An object of an embodiment of the present invention is to reduce unevenness of an image in a liquid crystal display device in which moving image display and still image display are switched, even in the case where characteristics such as a shift of threshold voltage of transistors of a plurality of protection circuits vary.

[0017] According to an embodiment of the present invention, a liquid crystal display device, in which display is performed by switching a still image display mode and a moving image display mode, includes a pixel including a transistor and a liquid crystal element, and a protection circuit electrically connected to one of a source and a drain of the transistor through a data line. The protection circuit includes a first terminal supplied with a first power supply potential and a second terminal supplied with a second power supply potential which is higher than the first power supply. In the moving image display mode, an image signal is input from the data line to the liquid crystal element through the transistor, and the first power supply potential is set at a first potential. In the still image display mode, the image signal stops being input from the data line to the liquid crystal element, and the first power supply potential is set at a second potential higher than the first potential. The second potential is equal to or close to (i.e., substantially the same as) the minimum value of the image signal.

[0018] The transistor may include an oxide semiconductor layer.

[0019] According to an embodiment of the present invention, a liquid crystal display device, in which display is performed by switching a still image display mode and a moving image display mode, includes a pixel including a first transistor and a liquid crystal element, and a second transistor which is diode-connected. One of a source and a drain of the second transistor is supplied with a power supply potential. The other of the source and the drain of the second transistor is electrically connected to one of a source and a drain of the first transistor through a data line. In the moving image display mode, an image signal is input from the data line to the liquid crystal element through the first transistor, and the power supply potential is set at a first potential. In the still image display mode, an image signal stops being input from the data line to the liquid crystal element, and the power supply potential is set at a second potential higher than the first potential. The second potential is the same as or close to the minimum value of the potential of the image signal.

[0020] The first transistor may include an oxide semiconductor layer.

[0021] The still image display mode and the moving image display mode may be switched by detecting a difference of the image signal between consecutive frame periods.

[0022] According to an embodiment of the present invention, in a liquid crystal display device in which moving image display and still image display are switched, image display can be performed stably even in the case where change in characteristics such as a shift of threshold voltage of a transistor of a protection circuit is caused.

[0023] According to an embodiment of the present invention, in a liquid crystal display device in which moving image

display and the still image display are switched, unevenness of an image can be reduced even in the case where characteristics such as a shift of threshold voltage of transistors of a plurality of protection circuits vary.

#### BRIEF DESCRIPTION OF THE DRAWINGS

[0024] FIG. 1 illustrates an example of a display panel of a liquid crystal display device.

[0025] FIG. 2 illustrates an example of a display panel of a liquid crystal display device.

[0026] FIG. 3 illustrates an example of a liquid crystal display device.

[0027] FIG. 4 is a timing diagram for illustrating an example of a method for driving a liquid crystal display device.

[0028] FIGS. 5A and 5B are timing diagrams for illustrating an example of a method for driving a liquid crystal display device.

[0029] FIG. 6 illustrates the frequency of writing of an image signal.

[0030] FIGS. 7A to 7D each illustrate an example of a structure of a transistor.

[0031] FIGS. 8A and 8B each illustrate an example of an electronic device.

[0032] FIG. 9 illustrates an example of an electronic device.

[0033] FIGS. 10A to 10F each illustrate an example of an electronic device.

[0034] FIGS. 11A to 11G each illustrate an example of a protection circuit.

[0035] FIGS. 12A and 12B each illustrate an example of a transistor.

[0036] FIGS. 13A to 13C each illustrate an example of an oxide semiconductor layer.

#### DETAILED DESCRIPTION OF THE INVENTION

[0037] Examples of embodiments of the present invention will be described below with reference to the drawings. Note that the present invention is not limited to the following description. Note that the present invention is not limited to the following description because it will be easily understood by those skilled in the art that various changes and modifications can be made without departing from the spirit and scope of the present invention. Therefore, the present invention should not be construed as being limited to the following description of the embodiments. In referring to the drawings, in some cases, the same reference numerals are used in common for the same portions in different drawings. Further, in some cases, the same hatching patterns are applied to similar parts, and the similar parts are not necessarily designated by reference numerals in different drawings.

[0038] Note that the contents in different embodiments can be combined with one another as appropriate. In addition, the contents of the embodiments can be replaced with each other as appropriate.

[0039] Further, in this specification, the term “k (k is a natural number)” is used in order to avoid confusion among components, and the terms do not limit the number of components.

[0040] Note that a difference between potentials at two points (also referred to as a potential difference) is generally referred to as voltage. However, in an electric circuit, a difference between the potential at one point and the potential serving as a reference (also referred to as a reference poten-

tial) is used in some cases. Volt (V) is used as the units either of voltage and a potential. Thus, in this specification, a potential difference between a potential at one point and the reference potential is sometimes used as a voltage at the point unless otherwise specified.

[0041] Note that in the liquid crystal display device, the transistor is a field-effect transistor having at least a source, a drain, and a gate unless otherwise specified.

[0042] A source refers to part of or the whole of a source electrode, or part of or the whole of a source wiring. A conductive layer having a function of both a source electrode and a source wiring is referred to as a source in some cases without distinction between a source electrode and a source wiring. A drain refers to part of or the whole of a drain electrode, or part of or the whole of a drain wiring. A conductive layer having a function of both a drain electrode and a drain wiring is referred to as a drain in some cases without distinction between a drain electrode and a drain wiring. A gate refers to part of or the whole of a gate electrode, or part of or the whole of a gate wiring. In some cases, the gate electrode is not distinguished from the gate wiring and a conductive layer having the functions of both the gate electrode and the gate wiring is referred to as a gate.

[0043] The source and drain of the transistor are interchanged in some cases depending on the structure, operation condition, or the like of the transistor.

[0044] Note that in this embodiment, an “on” state of a transistor means that a source and a drain thereof are electrically connected, while an “off” state of a transistor means that a source and a drain thereof are not electrically connected.

[0045] In this specification, off-state current of an n-channel transistor is referred to as current which flows between a source and a drain of the transistor when the potential of the drain is higher than that of the source and a gate and gate-source voltage ( $V_{gs}$ ) is lower than and equal to 0 V. In this specification, off-state current of a p-channel transistor is referred to as current which flows between a source and a drain of the transistor when the potential of the drain is lower than that of the source and the gate of the transistor and gate-source voltage ( $V_{gs}$ ) is higher than and equal to 0 V.

[0046] Note that in this specification, the phrase “A and B are connected to each other” indicates the case where A and B are directly connected to each other in addition to the case where A and B are electrically connected to each other. Specifically, the description that “A and B are connected to each other” includes cases where A and B are considered to have substantially the same potential in light of circuit operation, e.g., a case where A and B are connected through a switching element such as a transistor and A and B have the potentials substantially the same potential as each other when the switching element is on, a case where A and B are connected through a resistor and a potential difference between both ends of the resistor does not affect operation of a circuit including A and B, and the like.

#### Embodiment 1

[0047] In this embodiment, a display device in which moving image display and still image display are switched is described.

[0048] As an example of a display device of this embodiment, a structure of a liquid crystal display device and operation thereof are described below.

## &lt;Structure of Display Panel&gt;

**[0049]** FIG. 1 and FIG. 2 illustrate an example of a display panel of a liquid crystal display device in this embodiment.

**[0050]** In FIG. 1, a display panel 130 includes a pixel portion 100, a data driver 102, a gate driver 104, and a plurality of protection circuits 106. The data driver 102 inputs a signal to a data line 108. The gate driver 104 inputs a signal to a gate line 110.

**[0051]** The pixel portion 100 includes a plurality of pixels 112 arranged in matrix. The pixel 112 includes a transistor 114 connected to the gate line 110 and the data line 108, a capacitor 116, and a liquid crystal element 118 functioning as a display element. Note that although the liquid crystal element 118 is used as a display element in this embodiment, a light-emitting element or the like can be used.

**[0052]** One of a source and a drain of the transistor 114 is connected to the data line 108. An image signal (Video Data) is input from the data driver 102 through the data line 108.

**[0053]** As the image signal (Video Data), a positive signal and a negative signal are alternately input to the one of the source and the drain of the transistor 114. Here, the positive signal is referred to a signal whose potential is higher than a common potential (Vcom) which is a reference; the negative signal is referred to a signal whose potential is lower than the common potential (Vcom).

**[0054]** Note that the common potential (Vcom) is any potential which is a reference with respect to the potential of the image signal (Video Data), and may be set at GND, or 0 V, for example.

**[0055]** A gate of the transistor 114 is connected to the gate line 110, to which, as a power supply potential, a high power supply potential (VDD) and a low power supply potential (VSS) are input from the gate driver 104 through the gate line 110. Here, the high power supply potential (VDD) is higher than the maximum value of the image signal (Video Data); and the low power supply potential (VSS) is lower than the minimum value of the image signal (Video Data).

**[0056]** Note that when the high power supply potential (VDD) is supplied as the power supply potential, the transistor 114 is turned on, so that the image signal (Video Data) is input to the liquid crystal element 118 and the capacitor 116 through the transistor 114. When the low power supply potential (VSS) is supplied as the power supply potential, the transistor 114 is turned off, so that the image signal (Video Data) stops being input to the liquid crystal element 118 and the capacitor 116.

**[0057]** Here, as the transistor 114, a transistor including a semiconductor layer whose carrier number is extremely small is preferably used. As a transistor including a semiconductor layer whose carrier number is extremely small, a transistor including an oxide semiconductor layer can be used, for example.

**[0058]** An oxide semiconductor layer included in the transistor is preferably a highly-purified oxide semiconductor layer by sufficient removal of impurities such as hydrogen or water and sufficient supply of oxygen. The hydrogen concentration of the oxide semiconductor layer is  $5 \times 10^{15}$  atoms/cm<sup>3</sup> or less, preferably  $5 \times 10^{18}$  atoms/cm<sup>3</sup> or less, more preferably  $5 \times 10^{17}$  atoms/cm<sup>3</sup> or less. Note that the above hydrogen concentration of the oxide semiconductor layer is measured by secondary ion mass spectrometry (SIMS).

**[0059]** In the oxide semiconductor layer which is sufficiently reduced in hydrogen concentration and in which defect levels in the energy gap due to oxygen vacancy are

decreased by supplying a sufficient amount of oxygen, the carrier concentration is lower than  $1 \times 10^{12}$ /cm<sup>3</sup>, preferably lower than  $1 \times 10^{11}$ /cm<sup>3</sup>, further preferably lower than  $1.45 \times 10^{10}$ /cm<sup>3</sup>. For example, the off-state current (here, current per micrometer ( $\mu\text{m}$ ) of channel width) at room temperature (25° C.) is lower than or equal to 100 zA (1 zA (zeptoampere) is  $1 \times 10^{-21}$  A), preferably lower than or equal to 10 zA. In this manner, a transistor with good electrical characteristics can be obtained by using an i-type (intrinsic) oxide semiconductor or a substantially i-type oxide semiconductor.

**[0060]** In the case of forming a transistor including an oxide semiconductor containing an alkaline metal or an alkaline earth metal, the off-state current is increased. Thus, in the oxide semiconductor layer, the concentrations of an alkaline metal or an alkaline earth metal is preferably equal to or lower than  $2 \times 10^{16}$  atoms/cm<sup>3</sup>, more preferably equal to or lower than  $1 \times 10^{15}$  atoms/cm<sup>3</sup>. An alkaline metal or an alkaline earth metal which are contained in the oxide semiconductor layer are reduced as much as possible as described above, whereby a transistor with good electrical characteristics can be obtained.

**[0061]** Variation in a display state of the pixel 112 which is caused by the off-state current of the transistor can be suppressed by using such a transistor including the oxide semiconductor layer as the transistor 114, so that a holding period of the pixel 112 per one writing operation of the image signal (Video Data) can be longer. Accordingly, the interval between writing operations of the image signal (Video Data) can be longer. For example, the interval between the writing operations of the image signal (Video Data) can be 10 seconds or longer, 30 seconds or longer, or 1 minute or longer.

**[0062]** The liquid crystal element 118 includes a pixel electrode, a common electrode 126 (also referred to as a counter electrode), and a liquid crystal layer provided between the pixel electrode and the common electrode 126. The pixel electrode of the liquid crystal element 118 is connected to the other of the source and the drain transistor 114, to which the image signal (Video Data) is input through the transistor 114. The common potential (Vcom) is supplied to the common electrode 126 of the liquid crystal element 118.

**[0063]** The liquid crystal layer includes a plurality of liquid crystal molecules. The orientation state of liquid crystal molecules is mainly determined by voltage applied between the pixel electrode and the counter electrode, which varies the light transmittance of liquid crystal.

**[0064]** As the liquid crystal, for example, an electrically controlled birefringence liquid crystal (also referred to as an ECB liquid crystal), a liquid crystal to which dichroic pigment is added (also referred to as a GH liquid crystal), a polymer-dispersed liquid crystal, a discotic liquid crystal, or the like can be used. Note that as the liquid crystal, a liquid crystal exhibiting a blue phase may be used. The liquid crystal layer contains, for example, a liquid crystal composition including a liquid crystal exhibiting a blue phase and a chiral agent. The liquid crystal composition which includes a liquid crystal exhibiting a blue phase and a chiral agent has a short response time of 1 msec or less and is optically isotropic; thus, alignment treatment is not necessary and viewing angle dependence is small. Thus, the operation speed of a liquid crystal display device can be increased with the liquid crystal layer exhibiting a blue phase.

**[0065]** As a display mode of the liquid crystal display device, a TN (twisted nematic) mode, an IPS (in-plane-switching) mode, an STN (super twisted nematic) mode, a VA

(vertical alignment) mode, an ASM (axially symmetric aligned micro-cell) mode, an OCB (optically compensated birefringence) mode, an FLC (ferroelectric liquid crystal) mode, an AFLC (antiferroelectric liquid crystal) mode, an MVA (multi-domain vertical alignment) mode, a PVA (patterned vertical alignment) mode, an ASV (advanced super view) mode, a FFS (fringe field switching) mode, or the like may be used.

**[0066]** A liquid crystal display device performs image display by switching a plurality of time-divided images at high speed in a plurality of frame periods.

**[0067]** Here, in consecutive frame periods, for example, the  $n$ -th frame period and  $(n+1)$ th frame period, there are a case where a displayed image is changed and a case where a displayed image is not changed. In this specification, display in the case where the displayed image is changed is referred to as the moving image display, and display in the case where the displayed image is not changed is referred to as the still image display.

**[0068]** A driving method in which the level (polarity) of the voltages applied between the pixel electrode and the counter electrode of a liquid crystal element is inverted per frame period (the driving method also referred to as inversion driving) may be used for a display method of the liquid crystal display device. By using the inversion driving, an image burn-in can be prevented. Note that one frame period corresponds to a period for displaying an image for one screen.

**[0069]** Note that an image is an image formed using the pixel **112** of the pixel portion **100**.

**[0070]** A first terminal of the capacitor **116** is connected to the other of the source and the drain of the transistor **114**, to which the image signal (Video Data) is input through the transistor **114**. A second terminal of the capacitor **116** is connected to a capacitor line **124**, to which a common capacitor potential (Vescom) is supplied from the capacitor line **124**. Note that the structure may be used in which a switching element is additionally provided and the common capacitor potential (Vescom) is supplied to the second terminal of the capacitor **116** by turning on the switching element.

**[0071]** The capacitor **116** has a function as a storage capacitor. The capacitor **116** includes a first electrode which functions as part of or the whole of the first terminal, a second electrode which functions as part of or the whole of the second terminal, and a dielectric layer in which charge corresponding to voltage applied between the first electrode and the second electrode is accumulated. The capacitance of the capacitor **116** may be set considering off-state current of the transistor **114** or the like.

**[0072]** Further, the structure in which the capacitor **116** is not provided in the pixel **112** may be used. Omission of the capacitor **116** can improve the aperture ratio of the pixel **112**.

**[0073]** A first terminal **120** and a second terminal **122** are connected to the protection circuit **106**. A low power supply potential (HVSS) is supplied to the first terminal **120**. A high power supply potential (HVDD) is supplied to the second terminal **122**. The protection circuit **106** is connected to the one of the source and the drain of the transistor **114** in the pixel **112** through the data line **108**.

**[0074]** The high power supply potential (HVDD) is higher than the low power supply potential (HVSS). Further, the high power supply potential (HVDD) is higher than the common potential (Vcom). The low power supply potential (HVSS) is lower than the common potential (Vcom). Further-

more, the high power supply potential (HVDD) and the high power supply potential (VDD) may be equal to each other.

**[0075]** The low power supply potential (HVSS) is set at a first potential or a second potential higher than the first potential. The first potential is lower than the minimum value of the image signal (Video Data). Further, the first potential and the low power supply potential (VSS) may be equal to each other. The second potential is set at the minimum value of the image signal (Video Data) or the value close to the minimum value of the image signal (Video Data).

**[0076]** Note that although the protection circuit **106** is provided in the display panel **130** in FIG. 1, the structure of the protection circuit of this embodiment is not limited thereto. A structure in which a protection circuit is provided outside the display panel **130** and the protection circuit and the pixel portion **100** are connected through a wiring may be used.

**[0077]** Next, a structure of a circuit for one data line **108** in the display panel **130** of the liquid crystal display device in FIG. 1 is described with reference to FIG. 2.

**[0078]** The data driver **102** includes a plurality of transistors **200** functioning as sampling switches. The plurality of transistors **200** are arranged in parallel to form a sampling circuit.

**[0079]** One of a source and a drain of the transistor **200** is connected to the data line **108**. The image signal (Video Data) is input to the other of the source and the drain of the transistor **200**. A sampling pulse is input to a gate of the transistor **200**.

**[0080]** In accordance with a timing of inputting a sampling pulse to the gate of the transistor **200** among the plurality of transistors **200** included in a sampling circuit, the image signal (Video Data) is input to the data line **108** connected to the transistor. Specifically, when a sampling pulse is input to the gate of the transistor **200**, the transistor **200** is turned on and the image signal (Video Data) is input to the data line **108** through the transistor **200**.

**[0081]** The protection circuit **106** includes a plurality of diode-connected transistors connected in series.

**[0082]** As an example of the protection circuit **106**, FIG. 2 illustrates a structure in which a diode-connected transistor **202** and a diode-connected transistor **204** are provided and connected in series.

**[0083]** One of a source and a drain of the transistor **202** is connected to the first terminal **120**. The other of the source and the drain of the transistor **202** is connected to the data line **108**.

**[0084]** One of a source and a drain of the transistor **204** is connected to the data line **108**. The other of the source and the drain of the transistor **204** is connected to the second terminal **122**.

#### <Structure of Liquid Crystal Display Device>

**[0085]** Next, an example of a structure of a liquid crystal display device including the display panel **130** is described below.

**[0086]** In FIG. 3, a liquid crystal display device **300** includes an image processing circuit **310**, a power source **316**, and a display panel **320**. The display panel **320** in FIG. 3 corresponds to the display panel **130** in FIG. 1.

**[0087]** The liquid crystal display device **300** is connected to an external device. A signal (Data) including image data is input from the external device.

**[0088]** The signal (Data) including image data is input to the image processing circuit **310**. From the inputted signal (Data) including image data, the image processing circuit **310**

generates an image signal (Video Data) input to the display panel **320** and control signals (a start pulse (SSP) and a clock signal (SCLK) which are input to the data driver **102**, the start pulse (GSP) and a clock signal (GCLK) which are input to the gate driver **104**, or the like). Further, the image processing circuit **310** inputs a signal for controlling a transistor **327** included in the display panel **320** to a gate of the transistor **327**.

**[0089]** Note that in the case where the signal (Data) including image data is an analog signal, the analog signal may be converted into a digital signal through an A/D converter or the like and then input to the image processing circuit **310**. With such a structure, a change of the image signal (Video Data) can be easily detected in a later step.

**[0090]** The power source **316** of the liquid crystal display device **300** is turned on, so that the high power supply potential (VDD), the low power supply potential (VSS), the high power supply potential (HVDD), the low power supply potential (HVSS), the common potential (Vcom), and the like are supplied to the display panel **320** through the image processing circuit **310**.

**[0091]** The control signals (the start pulse (SSP), the clock signal (SCLK), the start pulse (GSP), the clock signal (GCLK), and the like) are input from a display control circuit **313** to the display panel **320**. The image signal (Video Data) selected in a selection circuit **315** is input from the display control circuit **313** to the display panel **320**.

**[0092]** Next, a structure of the image processing circuit **310** and a process of processing a signal or the like in the image processing circuit **310** are described below.

**[0093]** The image processing circuit **310** includes a memory circuit **311**, a comparison circuit **312**, the display control circuit **313**, and the selection circuit **315**.

**[0094]** The memory circuit **311** includes a plurality of frame memories **330**. By the frame memories **330**, the signals (Data) including image data which correspond to a plurality of frame periods are stored. The frame memory **330** may be formed using a memory element such as a dynamic random access memory (DRAM) or a static random access memory (SRAM).

**[0095]** Note that it is acceptable as long as the frame memory **330** has a structure in which the signal (Data) including image data is stored every frame period. The number of the frame memories **330** in the memory circuit **311** is not particularly limited. The image signal (Video Data) generated from the signal (Data) including image data which is stored in the frame memory **330** is selectively read by the comparison circuit **312** and the selection circuit **315**. Note that the frame memory **330** in FIG. 3 conceptually shows a memory region corresponding to one frame period.

**[0096]** The comparison circuit **312** selectively reads the image signals (Video Data) of consecutive frame periods, which are stored in the memory circuit **311**, compares the signals for each pixel, and detects a difference thereof. Note that the consecutive frame periods are a period which consists of a frame period and the adjacent frame period.

**[0097]** In this embodiment, the comparison circuit **312** detects whether there is a difference of the image signal (Video Data) between consecutive frame periods or not, whereby the operation of the display control circuit **313** and the operation of the selection circuit **315** are determined

**[0098]** In the case where in consecutive frame periods, a difference is detected in any of pixels by comparison of the image signal (Video Data) performed by the comparison cir-

cuit **312** (in the case where there is a difference), the comparison circuit **312** judges that the image signal (Video Data) is not for displaying a still image and the moving image display is performed in the consecutive frame periods in which the difference is detected.

**[0099]** Note that in the case where a difference is detected only in part of pixels in the consecutive frame periods, the image signal (Video Data) may be written to only the pixel(s) in which the difference is detected. In that case, the data driver **102** and the gate driver **104** each include a decoder.

**[0100]** On the other hand, in the case where in consecutive frame periods, a difference is not detected in all of pixels by comparison of the image signal (Video Data) in the comparison circuit **312** (in the case where there is not a difference), the comparison circuit **312** judges that the image signal (Video Data) is for displaying a still image and the still image display is performed in the consecutive frame periods in which a difference is not detected.

**[0101]** In this manner, by detecting whether there is a difference of the image signal (Video Data) between the consecutive frame periods, the comparison circuit **312** judges whether the signal is for displaying a still image or not (whether the signal is a signal for displaying a still image or a signal for displaying a moving image).

**[0102]** Note that in the above description, the case where the difference is detected is judged as the case where there is a difference; however, criterion of judgment of "there is a difference" is not limited thereto. For example, the case where an absolute value of a difference detected by the comparison circuit **312** exceeds a predetermined value may be judged as the case where there is a difference.

**[0103]** In the above description, the comparison circuit **312** in the liquid crystal display device **300** detects a difference of the image signal (Video Data) between consecutive frame periods, so that whether the image signal (Video Data) is a signal for displaying a still image or not is judged; however, this embodiment is not limited to this structure. A signal for judging whether the image signal (Video Data) is a signal for displaying a still image or not may be input to the liquid crystal display device **300** from the outside of the liquid crystal display device **300**.

**[0104]** The selection circuit **315** includes semiconductor elements functioning as a plurality of switching elements. As such a semiconductor element, a transistor or a diode can be used.

**[0105]** In the case where the comparison circuit **312** detects a difference of the image signal (Video Data) between the consecutive frame periods, the selection circuit **315** selects the image signal (Video Data) for displaying a moving image from the frame memories **330** in the memory circuit **311**, and inputs the signal to the display control circuit **313**.

**[0106]** In the case where the comparison circuit **312** does not detect a difference of the image signal (Video Data) between the consecutive frame periods, the selection circuit **315** does not input the image signal (Video Data) from the frame memories **330** included in the memory circuit **311** to the display control circuit **313**. With a structure in which the image signal (Video Data) is not input, power consumption of the liquid crystal display device **300** can be reduced.

**[0107]** Note that in a liquid crystal display device in this embodiment, a display mode in which the comparison circuit **312** judges the image signal (Video Data) as a signal for displaying a still image is referred to as a still image display mode. Further, a display mode in which the comparison cir-

circuit 312 judges the image signal (Video Data) as a signal for displaying a moving image is referred to as a moving image display mode.

[0108] The display control circuit 313 may have a function of selecting the moving image display mode or the still image display mode. For example, the following structure may be used: a user of the liquid crystal display device 300 selects the display mode of the liquid crystal display device 300 manually or by an external device, so that the moving image display mode and the still image display mode are switched.

[0109] A circuit (also referred to as a display mode selection circuit) having a function of selecting a display mode may be additionally provided, and the image signal (Video Data) may be input from the selection circuit 315 to the display control circuit 313 in accordance with a signal input from the display mode selection circuit.

[0110] For example, the following structure may be used: in the case where a signal for switching the display mode is input from the display mode selection circuit to the selection circuit 315 when the display device is operated in the still image display mode, the selection circuit 315 performs the mode (i.e., the moving image display mode) in which the inputted image signal (Video Data) is input even when the comparison circuit 312 does not detect a difference of the image signal (Video Data) between the consecutive frame periods.

[0111] For example, the following structure may be used: in the case where a signal for switching the display mode is input from the display mode selection circuit to the selection circuit 315 when the display device is operated in the moving image display mode, the selection circuit 315 performs the mode (i.e., the still image display mode) in which only the image signal (Video Data) of a selected frame period is input even when the comparison circuit 312 detects a difference of the image signal (Video Data) between the consecutive frame periods. In this case, even when the liquid crystal display device 300 is operated in the moving image display mode, the still image display is performed in the selected frame period.

[0112] In the display panel 320 in FIG. 3, the transistor 327 and a terminal portion 326 are illustrated in addition to the pixel portion 100 or the like in FIG. 1.

[0113] The common electrode 126 is provided over a substrate opposing the substrate provided with the pixel electrode. Liquid crystal of the liquid crystal element 118 is controlled by a vertical electric field generated by the pixel electrode and the common electrode 126.

[0114] Further, the common potential (Vcom) is supplied to the common electrode 126 through the transistor 327 in accordance with input of a signal from the display control circuit 313.

[0115] The gate of the transistor 327 is connected to the display control circuit 313 through the terminal portion 326, and a control signal is input from the display control circuit 313 to the gate of the transistor 327. A first terminal (one of a source and a drain) of the transistor 327 is connected to the display control circuit 313 through the terminal portion 326, and the common potential (Vcom) is supplied from the display control circuit 313 to the first terminal A second terminal (the other of the source and the drain) of the transistor 327 is connected to the common electrode 126.

[0116] Note that the transistor 327 may be provided over the same substrate as or a different substrate from at least one of a substrate provided with a driver portion 321 (i.e., the data driver 102, the gate driver 104, the protection circuit 106, and the like) and a substrate providing the pixel portion 100. In

addition, in stead of the transistor 327, a semiconductor element (e.g., a diode) functioning as a switching element may be used.

#### <Method for Driving Liquid Crystal Display Device>

[0117] Then, an example of a method for driving a liquid crystal display device in this embodiment is described with reference to timing diagrams illustrated in FIG. 4 and FIGS. 5A and 5B. Note that FIG. 4 and FIGS. 5A and 5B illustrate the waveform of a signal with a simple square wave in order to explain timing of inputting the signal. As a structure of a liquid crystal display device, the structure illustrated in FIG. 3 is used.

[0118] First, signals input to the display panel 320 are described with reference to the timing diagram in FIG. 4.

[0119] FIG. 4 shows the clock signal (GCLK) and the start pulse (GSP) which are input from the display control circuit 313 to the gate driver 104 and the clock signal (SCLK) and the start pulse (SSP) which are input from the display control circuit 313 to the data driver 102.

[0120] Furthermore, FIG. 4 illustrates the power supply potential (the high power supply potential (VDD) and the low power supply potential (VSS)) which are supplied to the gate of the transistor 114, the low power supply potential (HVSS) which is supplied to the first terminal 120 of the protection circuit 106, the image signal (Video Data) input to the data line 108, the image signal (Video Data) input to the pixel electrode, a gate potential and the potential of the first terminal of the transistor 327, and the potential of the common electrode 126.

[0121] A period 401 illustrated in FIG. 4 is a period for displaying a moving image.

[0122] In the period 401, a clock signal is input at all times as the clock signal (GCLK), and a pulse is input as the start pulse (GSP) in accordance with a vertical synchronization frequency. Further, in the period 401, a clock signal is input at all times as the clock signal (SCLK), and a pulse is input as the start pulse (SSP) in accordance with one gate selection period.

[0123] In the period 401, the high power supply potential (VDD) is supplied to the gate line 110 as the power supply potential, and the transistor 114 is turned on. The image signal (Video Data) is input from the data line 108 to the pixel electrode of the liquid crystal element 118 and the first terminal of the capacitor 116 through the transistor 114 in an on state.

[0124] In the period 401, a potential at which the transistor 327 is turned on is supplied from the display control circuit 313 to the gate of the transistor 327. Accordingly, the common potential (Vcom) is supplied to the common electrode 126 of the liquid crystal element 118 through the transistor 327 in an on state.

[0125] A period 402 illustrated in FIG. 4 corresponds to a period for displaying a still image.

[0126] In the period 402, the control signals (the clock signal (SCLK), the start pulse (SSP), the clock signal (GCLK), the start pulse (GSP), and the like) stop being input; therefore, the operation of the data driver 102 and the operation of the gate driver 104 are stopped. Power consumption can be reduced by stopping input of the control signals.

[0127] Further, in the period 402, the low power supply potential (VSS) is supplied to the gate line 110 as the power supply potential, and the transistor 114 is turned off. Since the transistor 114 is in an off state, the image signal (Video Data)

stops being input from the data line 108 to a pixel to allow the potential of the pixel electrode of the liquid crystal element 118 to exist in a floating state.

[0128] Note that although input of the image signal (Video Data) is stopped in the period 402 in FIG. 4, this embodiment is not limited thereto. The image signal (Video Data) may be written at regular intervals in accordance with the length of the period 402 and refresh rate in order to prevent deterioration of a still image.

[0129] A potential at which the transistor 327 is turned off is supplied from the display control circuit 313 to the gate of the transistor 327. When the transistor 327 is turned off, the common potential (Vcom) stops being supplied to the common electrode 126, so that the potential of the common electrode 126 of the liquid crystal element 118 is in a floating state. In this manner, the potentials of the both electrodes (i.e., the pixel electrode and the common electrode 126) of the liquid crystal element 118 are transformed to be in a floating state and no potential is additionally supplied, whereby a still image can be displayed.

[0130] Next, the operation of the display control circuit 313 in a period (a period 403 in FIG. 4) for switching from the moving image display to the still image display is described with reference to the timing diagram of FIG. 5A.

[0131] FIG. 5A illustrates the power supply potential (the high power supply potential (VDD) and the low power supply potential (VSS)), the low power supply potential (HVSS), and the gate potential of the transistor 327, which are supplied from the display control circuit 313. FIG. 5A also illustrates the clock signal (GCLK) and the start pulse (GSP) which are input from the display control circuit 313.

[0132] First, the start pulse (GSP) stops being input from the display control circuit 313 (E1 in FIG. 5A).

[0133] After input of the start pulse (GSP) stops and the image signal (Video Data) is written to all of the pixels, the clock signal (GCLK) stops being input from the display control circuit 313 (E2 in FIG. 5A).

[0134] Then, the power supply potential is changed from the high power supply potential (VDD) to the low power supply potential (VSS). After the high power supply potential (VDD) stops being supplied, the potential of the low power supply potential (HVSS) supplied to the first terminal 120 of the protection circuit 106 is increased from the first potential to the second potential (E3 in FIG. 5A). Here, the second potential has the same value of the minimum value of the image signal (Video Data) or a value close to the minimum value of the image signal (Video Data).

[0135] Note that in E3 in FIG. 5A, the timing at which the low power supply potential (VSS) is supplied and the timing at which the low power supply potential (HVSS) is increased are the same; however, this embodiment is not limited thereto. The low power supply potential (HVSS) is increased and becomes the second potential before the potential at which the transistor 327 is turned off is supplied to the gate of the transistor 327.

[0136] After that, the gate potential of the transistor 327 is set at the potential at which the transistor 327 is turned off (E4 in FIG. 5A).

[0137] Through the above procedure, input of a signal to the data driver 102 and the gate driver 104 can be stopped.

[0138] When overvoltage is generated by malfunction of the driver portion 321 in switching from the moving image display to the still image display, the still image display is adversely influenced. On the other hand, the display control

circuit 313 is used as described in this embodiment, so that a still image can be displayed without malfunction of the driver portion 321.

[0139] Then, the operation of the display control circuit 313 in a period (a period 404 in FIG. 4) for switching from the still image display to the moving image display is described with reference to the timing diagram of FIG. 5B.

[0140] FIG. 5B illustrates the power supply potential (the high power supply potential (VDD) and the low power supply potential (VSS)), the low power supply potential (HVSS), and the gate potential of the transistor 327, which are supplied from the display control circuit 313. FIG. 5A also illustrates the clock signal (GCLK) and the start pulse (GSP) are input from the display control circuit 313.

[0141] First, the gate potential of the transistor 327 is set at the potential at which the transistor 327 is turned on (S1 in FIG. 5B).

[0142] Then, the power supply potential is changed from the low power supply potential (VSS) to the high power supply potential (VDD). At the same time in which the high power supply potential (VDD) is supplied, the potential of the low power supply potential (HVSS) supplied to the first terminal 120 of the protection circuit 106 is decreased from the second potential to the first potential (S2 in FIG. 5B). Here, the first potential has a value lower than the minimum value of the image signal (Video Data). In addition, the first potential and the low power supply potential (HVSS) may have the same value.

[0143] Note that in S2 in FIG. 5B, the timing at which the high power supply potential (VDD) is supplied and the timing at which the low power supply potential (HVSS) is decreased are the same; however, this embodiment is not limited thereto. The low power supply potential (HVSS) is decreased and becomes the first potential before the start pulse (GSP) is input to the display panel 320.

[0144] Next, after all of the clock signals (GCLK) input to the display panel 320 is set at an H (high) level, the normal clock signal (GCLK) is input (S3 in FIG. 5B).

[0145] Then, the start pulse (GSP) is input to the display panel 320 (S4 in FIG. 5B).

[0146] Through the above procedure, input of a signal to the data driver 102 and the gate driver 104 can be resumed.

[0147] As described in this embodiment, the potentials of wirings are sequentially restored at the potentials in the moving image display, whereby a moving image can be displayed without malfunction of the driver portion 321.

[0148] In this embodiment, after the high power supply potential (VDD) stops being supplied, the low power supply potential (HVSS) supplied to the first terminal 120 of the protection circuit 106 is increased.

[0149] Here, after the high power supply potential (VDD) stops being supplied to the display panel 320 (E3 in FIG. 5A), the potential of the data line 108 is considered. Just after the high power supply potential (VDD) stops being supplied, the image signal (Video Data) is held by the liquid crystal element 118 and the capacitor 116.

[0150] First, the case where the low power supply potential (HVSS) supplied to the first terminal 120 of the protection circuit 106 is not increased and is maintained to be the first potential is described. Note that the first potential has a value lower than the minimum value of the image signal (Video Data).

[0151] Here, the potential of the data line 108 is decreased so as to approach the low power supply potential (HVSS) over

time by the leakage current of the transistor **202** in the case where the leakage current of the transistor **202** in an off state, which is included in the protection circuit **106**, is large.

[0152] Further, by decrease in the potential of the data line **108**, charge accumulated in the liquid crystal element **118** and the capacitor **116** easily moves to the data line **108** through the transistor **114** in an off state. If the charge moves to the data line **108**, the image signal (Video Data) cannot be held by the liquid crystal element **118** and the capacitor **116**.

[0153] For example, when a transistor is degraded by a long time use, variation in characteristics such as a shift of the threshold voltage occurs; accordingly the leakage current of a transistor in an off state might be increased. Therefore, in a liquid crystal display device in which the moving image display and the still image display are switched, when the transistor **202** included in the protection circuit **106** is degraded by a long time use, the liquid crystal element **118** cannot hold the image signal (Video Data) in the still image display because of the leakage current of the transistor **202**. As a result, an image cannot be stably displayed.

[0154] Further, when a transistor is degraded by light such as backlight or external light, variation in characteristics such as a shift of the threshold voltage occurs; accordingly the leakage current of a transistor in an off state might be increased. Therefore, in a liquid crystal display device in which the moving image display and the still image display are switched, when the transistor **202** included in the protection circuit **106** is degraded by light such as backlight or external light, the liquid crystal element **118** cannot hold the image signal (Video Data) in the still image display because of the leakage current of the transistor **202**. As a result, an image cannot be stably displayed.

[0155] Furthermore, when characteristics, such as threshold voltage, of the transistors **202** included in the plurality of protection circuits **106** vary, part of the transistors **202** would have extremely large leakage current in the off state. Therefore, in a liquid crystal display device in which the moving image display, the leakage current of the part of the transistors **202** does not allow the corresponding liquid crystal elements **118** to hold the image signal (Video Data) in the still image display. As a result, unevenness of an image is caused.

[0156] On the other hand, in this embodiment, after the high power supply potential (VDD) stops being supplied, the low power supply potential (HVSS) supplied to the first terminal **120** of the protection circuit **106** is increased and is set at the same as or close to the value of the second potential, that is, the minimum value of the image signal (Video Data).

[0157] Accordingly, a difference between the low power supply potential (HVSS) and the potential of the data line **108** can be smaller. Thus, reduction in the potential of the data line **108** can be suppressed.

[0158] Therefore, even when the transistor **202** included in the protection circuit **106** is degraded, the image signal (Video Data) can be stably held by the liquid crystal element **118** by suppression of reduction in the potential of the data line **108**. Thus, an image can be displayed stably.

[0159] Further, even when the characteristics of the transistors **202**, such as the threshold voltage, included in the plurality of protection circuits **106** are varied, the image signal (Video Data) can be stably held by the liquid crystal element **118** corresponding to the data line **108** by suppression of reduction in the potential of the data line **108**. Accordingly, unevenness of an image can be reduced.

[0160] Note that it is preferable that a transistor including an oxide semiconductor layer be used as the transistor **114** included in the pixel portion in addition to a method in which the low power supply potential (HVSS) supplied to the first terminal **120** of the protection circuit **106** is increased after the high power supply potential (VDD) stops being supplied. As a result, the leakage current of the transistor **114** can be reduced, whereby the liquid crystal element **118** can hold the image signal (Video Data) more certainly.

[0161] FIG. 6 schematically illustrates the frequency of writing of the image signal (Video Data) for each frame period in a period **601** in which a moving image is displayed and a period **602** in which a still image is displayed. In FIG. 6, "W" denotes a period for writing the image signal (Video Data) and "H" denotes a period for holding the image signal (Video Data).

[0162] In the liquid crystal display device **300** in this embodiment, the image signal (Video Data) of the still image displayed in the period **602** is written in a period **604**. The image signal (Video Data) written in the period **604** is held in a period other than the period **604** in the period **602**.

[0163] In this manner, in the period for displaying a still image with the liquid crystal display device **300** in this embodiment, the frequency of writing of the image signal (Video Data) can be reduced by extending the display time per one writing of the image signal (Video Data). Therefore, in the still image display, power consumption of displaying an image or the like can be reduced.

[0164] Further, when a still image is displayed by rewriting the same image signal (Video Data) plural times, eyes of a user (a human) might be fatigued when switching of images is perceptible. In the period for displaying a still image with the liquid crystal display device **300** in this embodiment, the frequency of writing of the image signal (Video Data) can be reduced by extending the display time per one writing of the image signal (Video Data). Therefore, in the still image display, eye fatigue of a user can be less severe.

[0165] As described above, the low power supply potential (HVSS) supplied to the first terminal **120** of the protection circuit **106** is increased after the high power supply potential (VDD) stops being supplied, whereby the image signal (Video Data) of the liquid crystal element **118** can be stably held. Accordingly, stable image display can be performed.

[0166] Further, the low power supply potential (HVSS) supplied to the first terminal **120** of the protection circuit **106** is increased after the high power supply potential (VDD) stops being supplied, whereby the image signal (Video Data) of the liquid crystal element **118** can be stably held. Accordingly, unevenness of an image can be reduced.

#### Embodiment 2

[0167] In this embodiment, a structure example of a transistor included in the liquid crystal display device which is described in Embodiment 1 will be explained.

[0168] As a structure example of a transistor, a structure of a transistor including an oxide semiconductor layer as a semiconductor layer is described with reference to FIGS. 7A to 7D and FIGS. 12A and 12B. FIGS. 7A to 7D and FIGS. 12A and 12B are cross-sectional schematic views.

[0169] A transistor in FIG. 7A is one of a bottom-gate transistors and also referred to as an inverted staggered transistor.

[0170] The transistor in FIG. 7A includes a conductive layer **711** which is provided over a substrate **710**, an insulat-

ing layer 712 which is provided over the conductive layer 711, an oxide semiconductor layer 713 which is provided over the conductive layer 711 with the insulating layer 712 provided therebetween, and a conductive layer 715 and a conductive layer 716 which are each provided over part of the oxide semiconductor layer 713.

[0171] Further, FIG. 7A illustrates an oxide insulating layer 717 which is in contact with the other part of the oxide semiconductor layer 713 (a portion in which the conductive layer 715 and the conductive layer 716 are not provided) of the transistor, and a protective insulating layer 719 which is provided over the oxide insulating layer 717.

[0172] A transistor in FIG. 7B is a channel protective (also referred to as a channel stop) transistor which is one of a bottom-gate transistors, and is also referred to as an inverted staggered transistor.

[0173] The transistor in FIG. 7B includes a conductive layer 721 which is provided over a substrate 720, an insulating layer 722 which is provided over the conductive layer 721, an oxide semiconductor layer 723 which is provided over the conductive layer 721 with the insulating layer 722 provided therebetween, an insulating layer 727 which is provided over the conductive layer 721 with the insulating layer 722 and the oxide semiconductor layer 723 provided therebetween, and a conductive layer 725 and a conductive layer 726 which are each provided over part of the oxide semiconductor layer 723 and part of the insulating layer 727.

[0174] Here, when part of or whole of the oxide semiconductor layer 723 overlaps the conductive layer 721, incidence of light to the oxide semiconductor layer 723 can be suppressed.

[0175] Further, FIG. 7B illustrates a protective insulating layer 729 which is provided over the transistor.

[0176] A transistor in FIG. 7C is one of a bottom-gate transistors.

[0177] The transistor in FIG. 7C includes a conductive layer 731 which is provided over a substrate 730; an insulating layer 732 which is provided over the conductive layer 731; a conductive layer 735 and a conductive layer 736 which are each provided over part of the insulating layer 732; and an oxide semiconductor layer 733 which is provided over the conductive layer 731 with the insulating layer 732, the conductive layer 735, and the conductive layer 736 provided therebetween.

[0178] Here, when part of or whole of the oxide semiconductor layer 733 overlaps the conductive layer 731, incidence of light to the oxide semiconductor layer 733 can be suppressed.

[0179] Further, FIG. 7C illustrates an oxide insulating layer 737 which is in contact with a top surface and a side surface of the oxide semiconductor layer 733, and a protective insulating layer 739 which is provided over the oxide insulating layer 737.

[0180] A transistor in FIG. 7D is one of top-gate transistors.

[0181] The transistor in FIG. 7D includes an oxide semiconductor layer 743 which is provided over a substrate 740 with an insulating layer 747 provided therebetween; a conductive layer 745 and a conductive layer 746 which are each provided over part of the oxide semiconductor layer 743; an insulating layer 742 which is provided over the oxide semiconductor layer 743, the conductive layer 745, and the conductive layer 746; and a conductive layer 741 which is provided over the oxide semiconductor layer 743 with the insulating layer 742 provided therebetween.

[0182] For each of the substrate 710, the substrate 720, the substrate 730, and the substrate 740, a glass substrate (e.g., a barium borosilicate glass substrate and an aluminoborosilicate glass substrate), a substrate formed of an insulator (e.g., a ceramic substrate, a quartz substrate, and a sapphire substrate), a crystallized glass substrate, a plastic substrate, a semiconductor substrate (e.g., a silicon substrate), or the like can be used.

[0183] In the transistor in FIG. 7D, the insulating layer 747 serves as a base layer preventing diffusion of an impurity element from the substrate 740. As an example, a single layer or a stacked layer of a silicon nitride layer, a silicon oxide layer, a silicon nitride oxide layer, a silicon oxynitride layer, an aluminum oxide layer, or an aluminum oxynitride layer can be used for the insulating layer 747. Alternatively, a stacked layer of the above layer and a layer of a material having a light-blocking property is used for the insulating layer 747. Further alternatively, a layer of a material having a light-blocking property is used for the insulating layer 747. Note that when a layer of a material having a light-blocking property is used as the insulating layer 747, incidence of light to the oxide semiconductor layer 743 can be suppressed.

[0184] Note that as in the transistor in FIG. 7D, in the transistors in FIGS. 7A to 7C, the insulating layer 747 can be formed between the substrate 710 and the conductive layer 711, between the substrate 720 and the conductive layer 721, and between the substrate 730 and the conductive layer 731.

[0185] The conductive layers (the conductive layer 711, the conductive layer 721, the conductive layer 731, and the conductive layer 741) have a function as a gate of the transistor. For these conductive layers, as an example, a layer including a metal such as molybdenum, titanium, chromium, tantalum, tungsten, aluminum, copper, neodymium, or scandium, or an alloy which contains the metal as a main component is used.

[0186] The insulating layers (the insulating layer 712, the insulating layer 722, the insulating layer 732, and the insulating layer 742) have a function as a gate insulating layer of the transistor.

[0187] A silicon oxide layer, a silicon nitride layer, a silicon oxynitride layer, a silicon nitride oxide layer, an aluminum oxide layer, an aluminum nitride layer, an aluminum oxynitride layer, an aluminum nitride oxide layer, a hafnium oxide layer, an aluminum gallium oxide layer, or the like can be used for the insulating layers (the insulating layer 712, the insulating layer 722, the insulating layer 732, and the insulating layer 742).

[0188] An insulating layer containing oxygen is preferably used for the insulating layers (the insulating layer 712, the insulating layer 722, the insulating layer 732, and the insulating layer 742) which have a function as a gate insulating layer in contact with the oxide semiconductor layers (the oxide semiconductor layer 713, the oxide semiconductor layer 723, the oxide semiconductor layer 733, and the oxide semiconductor layer 743). It is more preferable that the insulating layer containing oxygen has a region (also referred to as an oxygen excessive region) which contains oxygen larger in proportion than the stoichiometric proportion.

[0189] When the insulating layer having a function as a gate insulating layer includes the oxygen excessive region, oxygen can be prevented from being transferred from the oxide semiconductor layer to the insulating layer having a function as a gate insulating layer. Further, oxygen can be supplied to the oxide semiconductor layer from the insulating layer having a function as a gate insulating layer. Thus, the oxide semicon-

ductor layer in contact with the insulating layer having a function as a gate insulating layer can be a layer containing a sufficient amount of oxygen.

[0190] The insulating layers (the insulating layer 712, the insulating layer 722, the insulating layer 732, and the insulating layer 742) having a function as a gate insulating layer is preferably formed by using a method with which impurities such as hydrogen and water do not enter the insulating layers. The reason is as follows. When the insulating layer having a function as a gate insulating layer includes impurities such as hydrogen and water, entry of impurities such as hydrogen and water to the oxide semiconductor layers (the oxide semiconductor layer 713, the oxide semiconductor layer 723, the oxide semiconductor layer 733, and the oxide semiconductor layer 743), extraction of oxygen in the oxide semiconductor layers due to impurities such as hydrogen and water, or the like occurs. Thus, the oxide semiconductor layer might be reduced in resistance (n-type conductivity) and a parasitic channel might be formed. For example, the insulating layer having a function as a gate insulating layer is formed by sputtering. As a sputtering gas, a high-purity gas from which impurities such as hydrogen and water are removed is preferably used.

[0191] Further, treatment for supplying oxygen is preferably performed on the insulating layer having a function as a gate insulating layer. As the treatment for supplying oxygen, heat treatment in an oxygen atmosphere, oxygen doping treatment, and the like can be given. Alternatively, oxygen may be added by performing irradiation with oxygen ions accelerated by an electric field. Note that in this specification, "oxygen doping treatment" means addition of oxygen to a bulk, and the term "bulk" is used in order to clarify that oxygen is added not only to a surface of a film but also to the inside of the film. In addition, "oxygen doping" includes "oxygen plasma doping" in which plasmatized oxygen is added to a bulk.

[0192] Treatment for supplying oxygen is performed on the insulating layer having a function as a gate insulating layer, so that a region where the proportion of oxygen is higher than that of the stoichiometry is formed in the insulating layer having a function as a gate insulating layer. Providing such a region allows oxygen to be supplied to the oxide semiconductor layer, and accordingly, oxygen deficiency defects in the oxide semiconductor layer or the interface between the oxide semiconductor film and the second metal oxide film can be reduced.

[0193] For example, in the case where an aluminum gallium oxide layer is used as the insulating layer having a function as a gate insulating layer, treatment for supplying oxygen such as oxygen doping treatment is performed; thus, the composition of aluminum gallium oxide can be  $Ga_xAl_{2-x}O_{3+a}$  ( $0 < x < 2$ ,  $0 < a < 1$ ).

[0194] Note that a mixed gas containing an inert gas (e.g., nitrogen or a rare gas such as argon) and oxygen may be introduced during the deposition of the insulating layer having a function as a gate insulating layer by a sputtering method in order to supply oxygen thereto, whereby the oxygen excessive region may be formed in the insulating layer. Note that after the deposition by a sputtering method, heat treatment may be performed.

[0195] The oxide semiconductor layers (the oxide semiconductor layer 713, the oxide semiconductor layer 723, the oxide semiconductor layer 733, and the oxide semiconductor layer 743) have a function as a channel formation layer of the transistor. As an oxide semiconductor which can be used for

the oxide semiconductor layer, a quaternary metal oxide (an In—Sn—Ga—Zn-based metal oxide, or the like), a ternary metal oxide (an In—Ga—Zn-based metal oxide, an In—Sn—Zn-based metal oxide, an In—Al—Zn-based metal oxide, a Sn—Ga—Zn-based metal oxide, an Al—Ga—Zn-based metal oxide, a Sn—Al—Zn-based metal oxide, or the like), and a binary metal oxide (an In—Zn-based metal oxide, a Sn—Zn-based metal oxide, an Al—Zn-based metal oxide, a Zn—Mg-based metal oxide, a Sn—Mg-based metal oxide, an In—Mg-based metal oxide, an In—Ga-based metal oxide, an In—Sn-based metal oxide, or the like), or the like can be given. An In-based metal oxide, a Sn-based metal oxide, a Zn-based metal oxide, or the like can be used as the oxide semiconductor. Further, as an oxide semiconductor, an oxide semiconductor including silicon oxide ( $SiO_2$ ) in the above described metal oxides also can be used. Note that the oxide semiconductor may be amorphous or crystallized partly or entirely. When a crystalline oxide semiconductor is used as the oxide semiconductor, the oxide semiconductor is preferably formed over a level (flat) surface. Specifically, the oxide semiconductor is preferably formed over a surface whose average surface roughness (Ra) is 1 nm or less, further preferably 0.3 nm or less. Ra can be measured using an atomic force microscope (AFM).

[0196] A material represented by  $InMO_3(ZnO)_m$  ( $m > 0$ ) can be used as the oxide semiconductor. Here, M represents one or more metal elements selected from Sn, Zn, Ga, Al, Mn, and Co. For example, M can be Ga, Ga and Al, Ga and Mn, Ga and Co, or the like.

[0197] The conductive layers (the conductive layer 715, the conductive layer 716, the conductive layer 725, the conductive layer 726, the conductive layer 735, the conductive layer 736, the conductive layer 745, and the conductive layer 746) have a function as a source or a drain of the transistor. These conductive layers can be, for example, a layer of a metal such as aluminum, chromium, copper, tantalum, titanium, molybdenum, or tungsten; or an alloy containing the metal as a main component.

[0198] For example, as the conductive layer having a function as the source or the drain of the transistor, a stacked layer of a layer of a metal such as aluminum or copper, and a layer of a high-melting-point metal such as titanium, molybdenum, or tungsten is used. Alternatively, a plurality of layers of a high-melting-point metal with a layer of a metal such as aluminum or copper provided therebetween are used. Heat resistance of the transistor can be improved by using an aluminum layer to which an element for preventing generation of hillocks and whiskers (e.g., silicon, neodymium, or scandium) is added as the above conductive layer.

[0199] As a material of the conductive layer, indium oxide ( $In_2O_3$ ), tin oxide ( $SnO_2$ ), zinc oxide ( $ZnO$ ), a mixed oxide of indium oxide and tin oxide ( $In_2O_3—SnO_2$ , abbreviated as ITO), a mixed oxide of indium oxide and zinc oxide ( $In_2O_3—ZnO$ ), or such a metal oxide containing silicon oxide can be used, for example.

[0200] The insulating layer 727 has a function as a layer for protecting a channel formation layer of the transistor (also referred to as a channel protective layer).

[0201] As an example, an oxide insulating layer such as a silicon oxide layer is used for the oxide insulating layer 717 and the oxide insulating layer 737.

[0202] As an example, an inorganic insulating layer such as a silicon nitride layer, an aluminum nitride layer, a silicon nitride oxide layer, or an aluminum nitride oxide layer is used

for the protective insulating layer 719, the protective insulating layer 729, and the protective insulating layer 739.

[0203] An oxide conductive layer functioning as a source region and a drain region may be provided as a buffer layer between the oxide semiconductor layer 743 and the conductive layer 745 and between the oxide semiconductor layer 743 and the conductive layer 746. FIGS. 12A and 12B each illustrate a transistor in which an oxide conductive layer is provided for the transistor in FIG. 7D.

[0204] In each of transistors in FIGS. 12A and 12B, an oxide conductive layer 1602 and an oxide conductive layer 1604 which function as a source region and a drain region are formed between the oxide semiconductor layer 743 and the conductive layers 745 and 746 which function as the source and the drain. The transistors in FIGS. 12A and 12B are examples which differ in shapes of the oxide conductive layer 1602 and the oxide conductive layer 1604 from each other due to a manufacturing process.

[0205] In a transistor in FIG. 12A, the oxide conductive layer 1602 and the oxide conductive layer 1604 which function as the source region and the drain region are formed as follows. A stack of an oxide semiconductor film and an oxide conductive film is formed. The stack of the oxide semiconductor film and the oxide conductive film is processed by the same photolithography process to form the island-shaped oxide semiconductor layer 743 and an island-shaped oxide conductive film. Then, the conductive layer 745 and the conductive layer 746 which function as the source and the drain are formed over the oxide semiconductor layer 743 and the oxide conductive film. After that, the island-shaped oxide conductive film is etched using the conductive layer 745 and the conductive layer 746 as masks.

[0206] In the transistor in FIG. 12B, an oxide conductive film is formed over the oxide semiconductor layer 743, a metal conductive film is formed thereover, and the oxide conductive film and the metal conductive film are processed by the same photolithography process. Accordingly, the oxide conductive layer 1602 and the oxide conductive layer 1604, which function as the source region and the drain region, and the conductive layer 745 and the conductive layer 746, which function as the source and the drain, are formed.

[0207] Note that in the etching treatment for processing the shape of the oxide conductive layer, etching conditions (such as the kind of etchant, the concentration, and the etching time) are adjusted as appropriate so that the oxide semiconductor layer is not excessively etched.

[0208] As the formation method of the oxide conductive layers 1602 and 1604, a sputtering method, a vacuum evaporation method (an electron beam evaporation method or the like), an arc discharge ion plating method, or a spray method can be used. As a material of the oxide conductive layer, zinc oxide, zinc aluminum oxide, zinc aluminum oxynitride, gallium zinc oxide, indium tin oxide, or the like can be used. In addition, the above materials may contain silicon oxide.

[0209] By providing the oxide conductive layer as the source region and the drain region between the oxide semiconductor layer 743 and the conductive layers 745 and 746, which function as the source and the drain, reduction in resistance in the source region and the drain region can be achieved and the transistor can operate at high speed.

[0210] Further, the withstand voltage of the transistor can be increased with the oxide semiconductor layer 743, an oxide conductive layer (the oxide conductive layer 1602 or the oxide conductive layer 1604) which functions as the drain

region, and a conductive layer (the conductive layer 745 or the conductive layer 746) which functions as the drain.

### Embodiment 3

[0211] An example of an oxide semiconductor layer which can be used as the semiconductor layer of the transistor according to the above-mentioned embodiment is described with reference to FIGS. 13A to 13C.

[0212] An oxide semiconductor layer in this embodiment has a stacked structure in which a second crystalline oxide semiconductor layer which is thicker than a first crystalline oxide semiconductor layer is provided over the first crystalline oxide semiconductor layer.

[0213] An insulating layer 1702 is formed over an insulating layer 1700. In this embodiment, an oxide insulating layer with a thickness of larger than or equal to 50 nm and smaller than or equal to 60 nm is formed as the insulating layer 1702 by PCVD or sputtering. For example, a single layer or a stacked layer of a silicon oxide film, a gallium oxide film, an aluminum oxide film, a silicon nitride film, a silicon oxynitride film, an aluminum oxynitride film, or a silicon nitride oxide film can be used.

[0214] Then, a first oxide semiconductor film with a thickness of larger than and equal to 1 nm and smaller than or equal to 10 nm is formed over the insulating layer 1702. The first oxide semiconductor film is formed by sputtering and a substrate temperature at the time of forming the film is higher than or equal to 200° C. and lower than or equal to 400° C.

[0215] In this embodiment, the first oxide semiconductor film is formed to a thickness of 5 nm in an oxygen atmosphere, an argon atmosphere, or a mixed atmosphere of argon and oxygen as a sputtering gas under conditions that a target for an oxide semiconductor (a target for an In—Ga—Zn-based oxide semiconductor containing In<sub>2</sub>O<sub>3</sub>, Ga<sub>2</sub>O<sub>3</sub>, and ZnO at 1:1:2 [molar ratio]) is used, the distance between the substrate and the target is 170 mm, the substrate temperature is 250° C., the pressure is 0.4 Pa, and the direct current (DC) power is 0.5 kW. An In—Sn—Zn-based oxide semiconductor can be referred to as ITZO. In the case where an ITZO thin film is used as the oxide semiconductor film, a target for formation of a film of ITZO by a sputtering method may have a composition ratio of In:Sn:Zn=1:2:2, In:Sn:Zn=2:1:3, In:Sn:Zn=1:1:1, or In:Sn:Zn=20:45:35 in an atomic ratio, for example.

[0216] Next, an atmosphere of a chamber in which a substrate is placed is changed to a nitrogen atmosphere or a dry air and then first heat treatment is performed. The temperature of the first heat treatment is higher than or equal to 400° C. and lower than or equal to 750° C. A first crystalline oxide semiconductor layer 1704 is formed by the first heat treatment (see FIG. 13A).

[0217] The first heat treatment causes crystallization from a film surface and crystal grows from the film surface toward the inside of the film; thus, c-axis aligned crystal is obtained. By the first heat treatment, zinc and oxygen are concentrated at the film surface, and one or more layers of graphen-type two-dimensional crystal including zinc and oxygen and having a hexagonal upper plane are formed at the outermost surface; the layer(s) at the outermost surface grows in the thickness direction to form a stack of layers. By increasing the temperature of the heat treatment, crystal growth proceeds from the surface to the inside and further from the inside to the bottom.

[0218] By the first heat treatment, oxygen in the insulating layer 1702 that is an oxide insulating layer is diffused to an interface between the insulating layer 1702 and the first crystalline oxide semiconductor layer 1704 or the vicinity of the interface (within  $\pm 5$  nm from the interface), whereby oxygen deficiency in the first crystalline oxide semiconductor layer 1704 is reduced. Therefore, it is preferable that oxygen be included in (in a bulk of) the insulating layer 1702 used as a base insulating layer or at the interface between the first crystalline oxide semiconductor layer 1704 and the insulating layer 1702 at an amount that exceeds at least the stoichiometric composition ratio.

[0219] Next, a second oxide semiconductor layer with a thickness more than 10 nm is formed over the first crystalline oxide semiconductor layer 1704. The second oxide semiconductor layer is formed by sputtering, and the substrate temperature in the film formation is set to be higher than or equal to 200° C. and lower than or equal to 400° C. The film formation at the substrate temperature higher than or equal to 200° C. and lower than or equal to 400° C. allows the oxide semiconductor layer formed over the surface of the first crystalline oxide semiconductor layer to have an ordered morphology.

[0220] In this embodiment, the second oxide semiconductor layer is formed to a thickness of 25 nm in an oxygen atmosphere, an argon atmosphere, or a mixed atmosphere of argon and oxygen as a sputtering gas under conditions where a target for deposition of an In—Ga—Zn-based oxide semiconductor including  $\text{In}_2\text{O}_3$ ,  $\text{Ga}_2\text{O}_3$ , and  $\text{ZnO}$  at 1:1:2 [molar ratio] is used, the distance between the substrate and the target is 170 mm, the substrate temperature is 400° C., the pressure is 0.4 Pa, and the direct current (DC) power is 0.5 kW.

[0221] Next, second heat treatment is performed under a condition where the atmosphere of a chamber in which the substrate is set is an atmosphere of nitrogen or dry air. The temperature of the second heat treatment is higher than or equal to 400° C. and lower than or equal to 750° C. Through the second heat treatment, a second crystalline oxide semiconductor layer 1706 is formed (see FIG. 13B). The second heat treatment is performed in a nitrogen atmosphere, an oxygen atmosphere, or a mixed atmosphere of nitrogen and oxygen, whereby the density of the second crystalline oxide semiconductor layer is increased and the number of defects therein is reduced. By the second heat treatment, crystal growth proceeds in the thickness direction with the use of the first crystalline oxide semiconductor layer 1704 as a nucleus, that is, crystal growth proceeds from the bottom to the inside; thus, the second crystalline oxide semiconductor layer 1706 is formed.

[0222] It is preferable that steps from the formation of the insulating layer 1702 to the second heat treatment be successively performed without exposure to the ambient atmosphere. The steps from the formation of the insulating layer 1702 to the second heat treatment are preferably performed in an atmosphere which is controlled to include little hydrogen and moisture (such as an inert gas atmosphere, a reduced-pressure atmosphere, or a dry-air atmosphere); in terms of moisture, for example, a dry nitrogen atmosphere with a dew point of  $-40^\circ\text{C}$ . or lower, preferably a dew point of  $-50^\circ\text{C}$ . or lower may be employed.

[0223] Next, the stack of the oxide semiconductor layers, the first crystalline oxide semiconductor layer 1704 and the second crystalline oxide semiconductor layer 1706, is pro-

cessed into an island-shaped oxide semiconductor layer 1708 including the stack of the oxide semiconductor layers (see FIG. 13C). In FIG. 13C, the interface between the first crystalline oxide semiconductor layer 1704 and the second crystalline oxide semiconductor layer 1706 are indicated by a dotted line, and the first crystalline oxide semiconductor layer 1704 and the second crystalline oxide semiconductor layer 1706 are illustrated as a stack of oxide semiconductor layers; however, the interface is actually not distinct and is illustrated for easy understanding.

[0224] The stack of the oxide semiconductor layers can be processed by being etched after a mask having a desired shape is formed over the stack of the oxide semiconductor layers. The mask can be formed by a method such as photolithography. Alternatively, the mask may be formed by a method such as an ink-jet method.

[0225] For the etching of the stack of the oxide semiconductor layers, either dry etching or wet etching may be employed. Needless to say, both of them may be employed in combination.

[0226] A feature of the first crystalline oxide semiconductor layer and the second crystalline oxide semiconductor layer obtained by the above formation method is that they have c-axis alignment. Note that the first crystalline oxide semiconductor layer and the second crystalline oxide semiconductor layer have neither a single crystal structure nor an amorphous structure and are crystalline oxide semiconductors having c-axis alignment (also referred to as c-axis aligned crystalline (CAAC) oxide semiconductors). The first crystalline oxide semiconductor layer and the second crystalline oxide semiconductor layer partly include a crystal grain boundary.

[0227] Note that as a metal oxide which can be used for the first crystalline oxide semiconductor layer and the second crystalline oxide semiconductor layer, four-component metal oxides such as an In—Al—Ga—Zn—O-based metal oxide, an In—Al—Ga—Zn—O-based metal oxide, an In—Si—Ga—Zn—O-based metal oxide, an In—Ga—B—Zn—O-based metal oxide, and an In—Sn—Ga—Zn—O-based metal oxide; three-component metal oxides such as an In—Ga—Zn—O-based metal oxide, an In—Al—Zn—O-based metal oxide, an In—Sn—Zn—O-based metal oxide, an In—B—Zn—O-based metal oxide, a Sn—Ga—Zn—O-based metal oxide, an Al—Ga—Zn—O-based metal oxide, and a Sn—Al—Zn—O-based metal oxide; two-component metal oxides such as an In—Zn—O-based metal oxide, a Sn—Zn—O-based metal oxide, an Al—Zn—O-based metal oxide, and a Zn—Mg—O-based metal oxide; and a Zn—O-based metal oxide can be given. In addition, the above materials may include silicon oxide ( $\text{SiO}_2$ ). Here, for example, an In—Ga—Zn—O-based metal oxide means a metal oxide including indium (In), gallium (Ga), and zinc (Zn), and there is no particular limitation on the composition ratio. Further, the In—Ga—Zn—O-based metal oxide may include an element other than In, Ga, and Zn.

[0228] Without limitation to the two-layer structure in which the second crystalline oxide semiconductor layer is formed over the first crystalline oxide semiconductor layer, a stacked structure including three or more layers may be formed by repeating film formation treatment and heat treatment after the second crystalline oxide semiconductor layer is formed.

[0229] The oxide semiconductor layer 1708 including the stack of the oxide semiconductor layers formed by the above

formation method can be used for a transistor (e.g., the transistors described in Embodiment 1 and Embodiment 2) which can be applied to a semiconductor device disclosed in this specification.

[0230] Note that the transistors shown in FIG. 7C and FIG. 7D of Embodiment 2 have a structure in which carriers flow at an interface of the oxide semiconductor layer which is close to the gate and is in contact with the source and drain. In other words, current does not flow in the thickness direction (from one surface to the other surface; specifically, in the vertical direction in FIG. 7D) of the oxide semiconductor layer, but mainly flows along one of the interfaces of the oxide semiconductor layer; therefore, even when the transistor is applied with an external stress such as light, BT (bias temperature), and the like, deterioration of transistor characteristics is suppressed or reduced.

[0231] By forming a transistor with the use of a stack of a first crystalline oxide semiconductor layer and a second crystalline oxide semiconductor layer, like the oxide semiconductor layer 1708, the transistor can have stable electric characteristics and high reliability.

#### Embodiment 4

[0232] In this embodiment, an example of a protection circuit of the liquid crystal display device described in Embodiment 1 is explained with reference to FIGS. 11A to 11G.

[0233] As a protection circuit, a protection circuit 3000 illustrated in FIG. 11A may be used. The protection circuit 3000 is provided to prevent breakdown of elements or the like due to electro-static discharge (ESD) which are included in a pixel provided in the pixel portion 100 electrically connected to a wiring 3011. The protection circuit 3000 includes a transistor 3001 and a transistor 3002.

[0234] A first terminal of the transistor 3001 is connected to a wiring 3012, a second terminal of the transistor 3001 is electrically connected to the wiring 3011, and a gate of the transistor 3001 is electrically connected to the wiring 3011. A first terminal of the transistor 3002 is connected to a wiring 3013, a second terminal of the transistor 3002 is connected to the wiring 3011, and a gate of the transistor 3002 is connected to the wiring 3013.

[0235] When a potential of the wiring 3011 is between the low power supply potential (VSS) and the high power supply potential (VDD), the transistor 3001 and the transistor 3002 are turned off. Thus, a signal supplied to the wiring 3011 is supplied to the pixel which is connected to the wiring 3011.

[0236] Note that due to an adverse effect of static electricity, a potential which is higher than the high power supply potential (VDD) or a potential which is lower than the low power supply potential (VSS) is supplied to the wiring 3011 in some cases. In this case, the element in the pixel which is connected to the wiring 3011 might be broken by the potential which is higher than the high power supply potential (VDD) or the potential which is lower than the low power supply potential (VSS).

[0237] However, the transistor 3001 is turned on in the case where the static electricity exerts a potential higher than the high power supply potential (VDD) on the wiring 3011. Since electric charge accumulated in the wiring 3011 is transferred to the wiring 3012 through the transistor 3001, the potential of the wiring 3011 is lowered. On the other hand, the transistor 3002 is turned on in the case where the static electricity exerts a potential which is lower than the high power supply potential (VSS) on the wiring 3011. Since the electric charge accu-

mulated in the wiring 3011 is transferred to the wiring 3013 through the transistor 3002, the potential of the wiring 3011 is raised. Accordingly, the electrostatic destruction can be prevented.

[0238] In other words, by providing the protection circuit 3000 as described above, electrostatic destruction of the element included in the pixel connected to the wiring 3011 can be prevented.

[0239] Further, as a protection circuit, the protection circuits 3000 in FIG. 11B and FIG. 11C may be used. FIG. 11B illustrates a structure in which the transistor 3002 and the wiring 3013 are omitted from the structure in FIG. 11A. FIG. 11C illustrates a structure in which the transistor 3001 and the wiring 3012 are omitted from the structure in FIG. 11A.

[0240] Moreover, as a protection circuit, the protection circuit 3000 in FIG. 11D may be used. FIG. 11D illustrates a structure in which a transistor 3003 is connected in series between the wiring 3012 and the transistor 3001 of the structure in FIG. A, and the transistor 3004 is connected in series between the transistor 3002 and the wiring 3013 of the structure in FIG. A.

[0241] In FIG. 11D, a first terminal of the transistor 3003 is connected to the wiring 3012, a second terminal of the transistor 3003 is connected to the first terminal of the transistor 3001, and a gate of the transistor 3003 is connected to the first terminal of the transistor 3001. A first terminal of the transistor 3004 is connected to the wiring 3013, a second terminal of the transistor 3004 is connected to the first terminal of the transistor 3002, and a gate of the transistor 3004 is connected to the wiring 3013.

[0242] Furthermore, as a protection circuit, the protection circuit 3000 in FIG. 11E may be used. FIG. 11E illustrates a structure in which the gate of the transistor 3003 of the structure in FIG. D is not connected to the first terminal of the transistor 3001 but is connected to the gate of the transistor 3003, and the gate of the transistor 3002 of the structure in FIG. D is not connected to the second terminal of the transistor 3004 but is connected to the gate of the transistor 3004.

[0243] Further, as a protection circuit, the protection circuit 3000 in FIG. 11F may be used. FIG. 11F illustrates a structure in which transistors are connected in parallel between the wiring 3011 and the wiring 3012 of the structure in FIG. 11A, and transistors are connected in parallel between the wiring 3011 and the wiring 3013 of the structure in FIG. 11A. In FIG. 11F, the first terminal of the transistor 3003 is connected to the wiring 3012, the second terminal of the transistor 3003 is connected to the wiring 3011, and the gate of the transistor 3003 is connected to the wiring 3011. Further, the first terminal of the transistor 3004 is connected to the wiring 3013, the second terminal of the transistor 3004 is connected to the wiring 3011, and the gate of the transistor 3004 is connected to the wiring 3013.

[0244] Furthermore, as a protection circuit, the protection circuit 3000 in FIG. 11G may be used. FIG. 11G illustrates a structure in which a capacitor 3005 and a resistor 3006 are connected in parallel between the gate of the transistor 3001 and the first terminal of the transistor 3001 of the structure in FIG. 11A, and a capacitor 3007 and a resistor 3008 are connected in parallel between the gate of the transistor 3002 and the first terminal of the transistor 3002 of the structure in FIG. 11A.

[0245] Thus, breakage or degradation of the protection circuit 3000 itself can be prevented by using the structure in FIG. 11G.

[0246] For example, in the case where a voltage which is higher than power supply voltage is supplied to the wiring 3011, the gate-source voltage (V<sub>gs</sub>) of the transistor 3001 is raised. Thus, the transistor 3001 is turned on, so that the voltage of the wiring 3011 is lowered. However, since high voltage is applied between the gate of the transistor 3001 and the second terminal of the transistor 3001, the transistor might be damaged or deteriorate. In order to prevent damage or deterioration of the transistor, a gate voltage of the transistor 3001 is increased by using the capacitor 3005 so that the gate-source voltage (V<sub>gs</sub>) of the transistor 3001 is lowered. Specifically, when the transistor 3001 is turned on, a potential of the first terminal of the transistor 3001 is increased instantaneously. Then, with capacitive coupling of the capacitor 3005, the potential of the gate of the transistor 3001 is increased. In this manner, the gate-source voltage (V<sub>gs</sub>) of the transistor 300 can be lowered so that breakage or deterioration of the transistor 3001 can be suppressed.

[0247] Similarly, in the case where a voltage which is lower than the power supply potential is supplied to the wiring 3011, a voltage of the first terminal of the transistor 3002 is lowered instantaneously. Then, with capacitive coupling of the capacitor 3007, the voltage of the gate of the transistor 3002 is lowered. In this manner, the gate-source voltage (V<sub>gs</sub>) of the transistor 3002 can be lowered, so that breakage or deterioration of the transistor 3002 can be suppressed.

#### Embodiment 5

[0248] In this embodiment, electronic paper including the liquid crystal display device described in Embodiment 1 will be explained.

[0249] Electronic paper described in this embodiment can be used for electronic appliances of a variety of fields as long as they can display data. As an electronic device including electronic paper, an e-book reader (e-book), a poster, a transportation advertisement in a means for vehicles such as a train and a bus, various cards with display portions such as a credit card, and the like can be given. An example of an electronic device including electronic paper is described with reference to FIGS. 8A and 8B and FIG. 9.

[0250] FIG. 8A illustrates an example of a poster using electronic paper. A poster 810 can be posted on a wall, a pillar, and the like regardless of whether outdoors or indoors.

[0251] In the case where an advertising medium is printed paper, the advertisement needs to be replaced by hand for exchanging the advertised contents. On the other hand, in the case where the poster 810 including the liquid crystal display device described in Embodiment 1 is used as an advertising medium, the advertised contents can be replaced by changing the content displayed on the poster 810 without replacing the poster 810 itself.

[0252] Further, data may be transmitted or received wirelessly to/from the poster 810, so that the advertised contents can be replaced wirelessly.

[0253] In the poster including the liquid crystal display device described in Embodiment 1, the liquid crystal element can hold the image signal (Video Data) by suppression of reduction in potential of the data line even when a transistor in the protection circuit is degraded. Accordingly, stable image display can be performed.

[0254] Further, in the poster including the liquid crystal display device described in Embodiment 1, the liquid crystal elements corresponding to their respective data lines can hold the image signal (Video Data) by suppression of reduction in

potential of the data line even when the characteristics, such as the threshold voltage, of transistors in the plurality of protection circuits of the liquid crystal display vary. Accordingly, unevenness of an image can be reduced.

[0255] Further, in the liquid crystal display device described in Embodiment 1, time (time in which the still image display mode is performed) for displaying an image per one writing of the image signal (Video Data) is long; accordingly, the frequency of writing of the image signal (Video Data) can be reduced. Therefore, by using the liquid crystal display device for a poster, power consumption of image display or the like can be reduced and eye fatigue of a user looking at the poster can be suppressed.

[0256] Further, FIG. 8B illustrates an example of a car card advertisement formed using electronic paper. A car card advertisement is an advertisement in vehicles such as a train and a bus. A hanging poster 820 and a poster 822 above the window can be given as advertisements. Here, the hanging poster 820 is an advertising medium hanging on the center of the ceiling in cars. The poster 822 above the window is an advertising medium positioned such that a standing passenger naturally sees.

[0257] In the case where an advertising medium is printed paper, the advertisement needs to be replaced by hand for exchanging the advertised contents. On the other hand, in the case where the hanging poster 820, the poster 822 above the window, or the like including the liquid crystal display device described in Embodiment 1 is used as an advertising medium, the advertised contents are can be replaced by changing the content displayed on the advertisement without the advertisement itself replaced.

[0258] Further, data may be transmitted or received wirelessly to/from the hanging poster 820 or the poster 822 above the window, so that the advertised contents can be replaced wirelessly.

[0259] In the advertisement such as a hanging poster or a poster on an upper side wall including the liquid crystal display device described in Embodiment 1, the liquid crystal element can hold the image signal (Video Data) by suppression of reduction in potential of the data line even when a transistor in the protection circuit is degraded. Accordingly, stable image display can be performed.

[0260] Further, in the advertisement such as a hanging poster or a poster on an upper side wall including the liquid crystal display device described in Embodiment 1, the liquid crystal elements corresponding to their respective data lines can hold the image signal (Video Data) by suppression of reduction in potential of the data line even when the characteristics, such as the threshold voltage, of transistors in the plurality of protection circuits of the liquid crystal display vary. Accordingly, unevenness of an image can be reduced.

[0261] Further, in the liquid crystal display device described in Embodiment 1, time (time in which the still image display mode is performed) for displaying an image per one writing of the image signal (Video Data) is long; accordingly, the frequency of writing of the image signal (Video Data) can be reduced. Therefore, by using the liquid crystal display device for an advertisement such as a hanging poster or a poster on an upper side wall, power consumption of image display or the like can be reduced and eye fatigue of a user looking at the advertisement can be suppressed.

[0262] FIG. 9 illustrates an example of an e-book reader.

[0263] An e-book reader 900 includes two housings (a housing 902 and a housing 904). The housing 902 and the

housing 904 are combined with a hinge 910 so that the e-book reader 900 can be opened and closed with the hinge 910 as an axis. With such a structure, the e-book reader 900 can operate like a paper book.

[0264] A display portion 906 is incorporated in the housing 902. A display portion 908 is incorporated in the housing 904. The display portions 906 and 908 may display one image or different images. According to the structure where different images are displayed in different display portions, for example, text can be displayed on the right display portion (the display portion 906 in FIG. 9) and images can be displayed on the left display portion (the display portion 908 in FIG. 9).

[0265] Further, the housing 902 of the e-book reader 900 is provided with an operation portion including an operation key 912 and the like, a power switch 914, a speaker 916, and the like. With the operation key 912, pages can be turned. Note that a keyboard, a pointing device, or the like may be provided on the surface of the housing, on which the display portion is provided. Further, an external connection terminal (an earphone terminal, a USB terminal, a terminal that can be connected to an AC adapter and various cables such as a USB cable, or the like), a recording medium insert portion, or the like may be provided on the back surface or the side surface of the housing 902 or the housing 904. Further, the e-book reader 900 may have a function of an electronic dictionary.

[0266] The e-book reader 900 may have a structure capable of wirelessly transmitting and receiving data. With such a structure, a desired book data or the like is purchased and downloaded from an e-book server wirelessly.

[0267] In the e-book reader including the liquid crystal display device described in Embodiment 1, the liquid crystal element can hold the image signal (Video Data) by suppression of reduction in potential of the data line even when a transistor in the protection circuit is degraded. Accordingly, stable image display can be performed.

[0268] Further, in the e-book reader including the liquid crystal display device described in Embodiment 1, the liquid crystal elements corresponding to their respective data lines can hold the image signal (Video Data) by suppression of reduction in potential of the data line even when the characteristics, such as the threshold voltage, of transistors in the plurality of protection circuits of the liquid crystal display vary. Accordingly, unevenness of an image can be reduced.

[0269] Further, in the liquid crystal display device described in Embodiment 1, time (time in which the still image display mode is performed) for displaying an image per one writing of the image signal (Video Data) is long; accordingly, the frequency of writing of the image signal (Video Data) can be reduced. Therefore, by using the liquid crystal display device for an e-book reader, power consumption of image display or the like can be reduced and eye fatigue of a user can be less severe.

#### Embodiment 6

[0270] In this embodiment, electronic devices including the liquid crystal display device described in the above embodiment in their display portions are described.

[0271] By applying the liquid crystal display device described in Embodiment 1 to display portions of a variety of electronic devices, a variety of functions in addition to a display function can be provided for the electronic devices. Examples of the electronic devices are a television device (also referred to as a television or a television receiver), a

display of a computer or the like, a notebook personal computer, a camera such as a digital camera or a digital video camera, a digital photo frame, a mobile phone (also referred to as a mobile telephone or a mobile phone device), a portable game console, a digital assistant, an information guide terminal, an audio reproducing device, and the like. An example of the electronic device is described with reference to FIGS. 10A to 10F.

[0272] FIG. 10A illustrates an example of a personal digital assistant.

[0273] The personal digital assistant illustrated in FIG. 10A includes at least a display portion 1001. The personal digital assistant illustrated in FIG. 10A can be combined with a touch panel or the like, and can be used as an alternative to a variety of portable objects. As illustrated in FIG. 10A, a personal digital assistant can be used as a cell phone by providing an operation portion 1002 with the personal digital assistant, for example. Note that an operation button may be provided instead of the operation portion 1002. Further, a personal digital assistant illustrated in FIG. 10A can be used as a notepad, a handy scanner provided with a text input-output function.

[0274] In the liquid crystal display device described in Embodiment 1, the liquid crystal element can hold the image signal (Video Data) by suppression of reduction in potential of the data line even when a transistor in the protection circuit is degraded. Accordingly, stable image display can be performed in a display portion of a personal digital assistant.

[0275] Further, in the liquid crystal display device described in Embodiment 1, the liquid crystal elements corresponding to their respective data lines can hold the image signal (Video Data) by suppression of reduction in potential of the data line even when the characteristics, such as the threshold voltage, of transistors in the plurality of protection circuits of the liquid crystal display vary. Accordingly, unevenness of an image can be reduced in a display portion of a personal digital assistant.

[0276] Further, in the liquid crystal display device described in Embodiment 1, time (time in which the still image display mode is performed) for displaying an image per one writing of the image signal (Video Data) is long; accordingly, the frequency of writing of the image signal (Video Data) can be reduced. Therefore, by using the liquid crystal display device for a display portion of a personal digital assistant, power consumption of image display or the like can be reduced and eye fatigue of a user can be less severe.

[0277] FIG. 10B illustrates an example of an information guide terminal including an automotive navigation system, for example.

[0278] An information guide terminal illustrated in FIG. 10B includes at least a display portion 1101. An information guide terminal illustrated in FIG. 10B may include an operation button 1102, an external input terminal 1103, and the like.

[0279] In the liquid crystal display device described in Embodiment 1, the liquid crystal element can hold the image signal (Video Data) by suppression of reduction in potential of the data line even when a transistor in the protection circuit is degraded. Accordingly, stable image display can be performed in a display portion of an information guide terminal.

[0280] Further, in the liquid crystal display device described in Embodiment 1, the liquid crystal elements corresponding to their respective data lines can hold the image

signal (Video Data) by suppression of reduction in potential of the data line even when the characteristics, such as the threshold voltage, of transistors in the plurality of protection circuits of the liquid crystal display vary. Accordingly, unevenness of an image can be reduced in a display portion of an information guide terminal.

[0281] Further, in the liquid crystal display device described in Embodiment 1, time (time in which the still image display mode is performed) for displaying an image per one writing of the image signal (Video Data) is long; accordingly, the frequency of writing of the image signal (Video Data) can be reduced. Therefore, by using the liquid crystal display device for a display portion of an information guide terminal, power consumption of image display or the like can be reduced and eye fatigue of a user can be less severe.

[0282] FIG. 10C illustrates an example of a notebook personal computer.

[0283] The notebook personal computer illustrated in FIG. 10C includes a housing 1201, a display portion 1202, a speaker 1203, an LED lamp 1204, a pointing device 1205, a connection terminal 1206, a keyboard 1207, and the like.

[0284] In the liquid crystal display device described in Embodiment 1, the liquid crystal element can hold the image signal (Video Data) by suppression of reduction in potential of the data line even when a transistor in the protection circuit is degraded. Accordingly, stable image display can be performed in a display portion of a personal computer.

[0285] Further, in the liquid crystal display device described in Embodiment 1, the liquid crystal elements corresponding to their respective data lines can hold the image signal (Video Data) by suppression of reduction in potential of the data line even when the characteristics, such as the threshold voltage, of transistors in the plurality of protection circuits of the liquid crystal display vary. Accordingly, unevenness of an image can be reduced in a display portion of a personal computer.

[0286] Further, in the liquid crystal display device described in Embodiment 1, time (time in which the still image display mode is performed) for displaying an image per one writing of the image signal (Video Data) is long; accordingly, the frequency of writing of the image signal (Video Data) can be reduced. Therefore, by using the liquid crystal display device for a display portion of a personal computer, power consumption of image display or the like can be reduced and eye fatigue of a user can be less severe.

[0287] FIG. 10D illustrates an example of a portable game machine.

[0288] The portable game machine illustrated in FIG. 10D includes a first display portion 1301, a second display portion 1302, a speaker 1303, a connection terminal 1304, an LED lamp 1305, a microphone 1306, a recording medium reading portion 1307, an operation button 1308, a sensor 1309, and the like.

[0289] In the liquid crystal display device described in Embodiment 1, the liquid crystal element can hold the image signal (Video Data) by suppression of reduction in potential of the data line even when a transistor in the protection circuit is degraded. Accordingly, stable image display can be performed in a display portion of a portable game machine.

[0290] Further, in the liquid crystal display device described in Embodiment 1, the liquid crystal elements corresponding to their respective data lines can hold the image signal (Video Data) by suppression of reduction in potential

of the data line even when the characteristics, such as the threshold voltage, of transistors in the plurality of protection circuits of the liquid crystal display vary. Accordingly, unevenness of an image can be reduced in a display portion of a portable game machine.

[0291] Further, in the liquid crystal display device described in Embodiment 1, time (time in which the still image display mode is performed) for displaying an image per one writing of the image signal (Video Data) is long; accordingly, the frequency of writing of the image signal (Video Data) can be reduced. Therefore, by using the liquid crystal display device for a display portion of a portable game machine, power consumption of image display or the like can be reduced and eye fatigue of a user can be less severe.

[0292] Further, a moving image can be displayed on one of the display portions (the first display portion 1301 and the second display portion 1302) while a still image can be displayed on the other thereof. In this manner, supply of a signal to the driver can be stopped in the display portion displaying the still image, so that power consumption for image display on the display portion displaying the still image can be reduced.

[0293] FIG. 10E illustrates an example of a stationary information terminal.

[0294] The stationary information terminal illustrated in FIG. 10E includes at least a display portion 1401. Moreover, additional operation buttons or the like may be provided for the plane portion 1402. The stationary information communication terminal illustrated in FIG. 10E can be used for an automated teller machine or an information communication terminal (also referred to as a multimedia station) for ordering information goods such as a ticket (including a coupon).

[0295] In the liquid crystal display device described in Embodiment 1, the liquid crystal element can hold the image signal (Video Data) by suppression of reduction in potential of the data line even when a transistor in the protection circuit is degraded. Accordingly, stable image display can be performed in a display portion of a stationary information terminal.

[0296] Further, in the liquid crystal display device described in Embodiment 1, the liquid crystal elements corresponding to their respective data lines can hold the image signal (Video Data) by suppression of reduction in potential of the data line even when the characteristics, such as the threshold voltage, of transistors in the plurality of protection circuits of the liquid crystal display vary. Accordingly, unevenness of an image can be reduced in a display portion of a stationary information terminal.

[0297] Further, in the liquid crystal display device described in Embodiment 1, time (time in which the still image display mode is performed) for displaying an image per one writing of the image signal (Video Data) is long; accordingly, the frequency of writing of the image signal (Video Data) can be reduced. Therefore, by using the liquid crystal display device for a display portion of a stationary information terminal, power consumption of image display or the like can be reduced and eye fatigue of a user can be less severe.

[0298] FIG. 10F illustrates an example of a display.

[0299] The display illustrated in FIG. 10F includes a housing 1501, a display portion 1502, a speaker 1503, an LED lamp 1504, an operation button 1505, a connection terminal 1506, a sensor 1507, a microphone 1508, a support base 1509, and the like.

**[0300]** In the liquid crystal display device described in Embodiment 1, the liquid crystal element can hold the image signal (Video Data) by suppression of reduction in potential of the data line even when a transistor in the protection circuit is degraded. Accordingly, stable image display can be performed in a display portion of a display.

**[0301]** Further, in the liquid crystal display device described in Embodiment 1, the liquid crystal elements corresponding to their respective data lines can hold the image signal (Video Data) by suppression of reduction in potential of the data line even when the characteristics, such as the threshold voltage, of transistors in the plurality of protection circuits of the liquid crystal display vary. Accordingly, unevenness of an image can be reduced in a display portion of a display.

**[0302]** Further, in the liquid crystal display device described in Embodiment 1, time (time in which the still image display mode is performed) for displaying an image per one writing of the image signal (Video Data) is long; accordingly, the frequency of writing of the image signal (Video Data) can be reduced. Therefore, by using the liquid crystal display device for a display portion of a display, power consumption of image display or the like can be reduced and eye fatigue of a user can be less severe.

**[0303]** By using the liquid crystal display device described in Embodiment 1 for a display portion of an electronic device, the liquid crystal element can hold the image signal (Video Data) even when a transistor in the protection circuit is degraded. Accordingly, stable image display can be performed in the display portion of the electronic device.

**[0304]** Further, by using the liquid crystal display device described in Embodiment 1 for a display portion of an electronic device, leakage current due to variation in characteristics of a transistor can be suppressed even in the case of using for a long time. Accordingly, stable image display can be performed in a display portion of an electronic device.

**[0305]** Furthermore, by using the liquid crystal display device described in Embodiment 1 for a display portion of an electronic device, the liquid crystal element can hold the image signal (Video Data) even when the characteristics, such as the threshold voltage, of transistors in the plurality of protection circuits of the liquid crystal display vary. Accordingly, unevenness of an image can be reduced in the display portion of the electronic device.

**[0306]** Further, in the liquid crystal display device described in Embodiment 1, time (time in which the still image display mode is performed) for displaying an image per one writing of the image signal (Video Data) is long; accordingly, the frequency of writing of the image signal (Video Data) can be reduced. Therefore, by using the liquid crystal display device for a display portion of an electronic device, power consumption of image display or the like can be reduced and eye fatigue of a user can be less severe.

**[0307]** This application is based on Japanese Patent Application serial no. 2010-178132 filed with Japan Patent Office on Aug. 6, 2010, the entire contents of which are hereby incorporated by reference.

1. (canceled)

2. A liquid crystal display device comprising:

a data line configured to be supplied with an image signal;  
a pixel comprising a liquid crystal element and a transistor which is electrically connected to the liquid crystal element and the data line;

a gate line capable of switching the transistor between an on state and an off state; and

a protection circuit electrically connected to the data line, wherein the protection circuit is configured to supply a first potential to the data line when the transistor is in the on state and to supply a second potential to the data line when the transistor is in the off state, and

wherein the first potential is lower than a minimum potential of the image signal and the second potential is substantially the same as the minimum potential of the image signal.

3. A display device comprising:

a pixel portion comprising:

a data line; and

a plurality of pixels arranged along the data line, each of the plurality of pixels comprising:

a display element comprising a pixel electrode and a common electrode; and

a first transistor electrically connected to the data line and the pixel electrode;

a data driver electrically connected to the data line; and  
a protection circuit electrically connected to the data line, wherein the pixel portion is located between the data driver and the protection circuit, and

wherein the protection circuit comprises a second transistor and a third transistor each comprising a first terminal, a second terminal, and a gate,

wherein the first terminal of the second transistor is electrically connected to the gate of the second transistor, and

wherein the second terminal of the second transistor is electrically connected to the data line, the first terminal of the third transistor, and the gate of the third transistor.

4. The display device according to claim 3, further comprising a first resistor and a first capacitor which are electrically connected in parallel between the first terminal of the second transistor and the gate of the second transistor.

5. The display device according to claim 3, further comprising:

a fourth transistor and a fifth transistor each comprising a first terminal, a second terminal, and a gate,

wherein the first terminal of the fourth transistor is electrically connected to the first terminal of the second transistor and the gate of the fourth transistor,

wherein the second terminal of the fourth transistor is electrically connected to the first terminal of the fifth transistor and the gate of the fifth transistor, and

wherein the second terminal of the fifth transistor is electrically connected to the second terminal of the third transistor.

6. The display device according to claim 3, further comprising a sixth transistor electrically connected to the common electrodes.

7. The display device according to claim 3, wherein the first transistors each comprise a semiconductor layer which comprises an oxide semiconductor.

8. The display device according to claim 3,

wherein the pixel portion further comprises a gate line electrically connected to at least one of the first transistors, and

wherein the second terminal of the third transistor is configured to be input with a high-power supply potential which is higher than a potential applied to the common

electrodes and equal to or lower than a potential applied to the gate line to turn on the first transistor.

- 9.** The display device according to claim **8**, wherein the first terminal of the second transistor is configured to be input with a low-power supply potential which is lower than the high-power supply potential, wherein the low-power supply potential is configured to be set at a first potential or a second potential which is higher than the second potential, and wherein the first potential is lower than a minimum potential input to the data line or equal to a potential applied to the gate line to turn off the first transistor.
- 10.** The display device according to claim **3**, wherein the first transistor is configured to be input with a positive signal and a negative signal alternately.
- 11.** An electronic device comprising the display device according to claim **3**.
- 12.** A display device comprising:  
a pixel portion comprising:  
a data line; and  
a plurality of pixels arranged along the data line, each of the plurality of pixels comprising:  
a display element comprising a pixel electrode and a common electrode; and  
a first transistor electrically connected to the data line and the pixel electrode;  
a data driver electrically connected to the data line; and  
a protection circuit electrically connected to the data line, wherein the pixel portion is located between the data driver and the protection circuit, and  
wherein the protection circuit comprises a second transistor, a third transistor, a fourth transistor, and a fifth transistor, each of which comprises a first terminal, a second terminal, and a gate,  
wherein the first terminal of the second transistor is electrically connected to the gate of the second transistor,  
wherein the second terminal of the second transistor is electrically connected to the first terminal of the third transistor and the gate of the third transistor,  
wherein the second terminal of the third transistor is electrically connected to the data line, the first terminal of the fourth transistor, and the gate of the fourth transistor, and

wherein the second terminal of the fourth transistor is electrically connected to the first terminal of the fifth transistor and the gate of the fifth transistor.

- 13.** The display device according to claim **12**, wherein the gate of the second transistor is electrically connected to the gate of the third transistor, and wherein the gate of the fourth transistor is electrically connected to the gate of the fifth transistor.
- 14.** The display device according to claim **12**, further comprising a sixth transistor electrically connected to the common electrodes.
- 15.** The display device according to claim **12**, wherein the first transistors each comprise a semiconductor layer which comprises an oxide semiconductor.
- 16.** The display device according to claim **12**, wherein the pixel portion further comprises a gate line electrically connected to at least one of the first transistors, and  
wherein the second terminal of the third transistor is configured to be input with a high-power supply potential which is higher than a potential applied to the common electrodes and equal to or lower than a potential applied to the gate line to turn on the first transistor.
- 17.** The display device according to claim **16**, wherein the first terminal of the second transistor is configured to be input with a low-power supply potential which is lower than the high-power supply potential, wherein the low-power supply potential is configured to be set at a first potential or a second potential which is higher than the second potential, and  
wherein the first potential is lower than a minimum potential input to the data line or equal to a potential applied to the gate line to turn off the first transistor.
- 18.** The display device according to claim **12**, wherein the first transistor is configured to be input with a positive signal and a negative signal alternately.
- 19.** An electronic device comprising the display device according to claim **13**.

\* \* \* \* \*

专利名称(译)	液晶显示装置及其驱动方法		
公开(公告)号	<a href="#">US20140204073A1</a>	公开(公告)日	2014-07-24
申请号	US14/219275	申请日	2014-03-19
[标]申请(专利权)人(译)	株式会社半导体能源研究所		
申请(专利权)人(译)	半导体能源研究所有限公司.		
当前申请(专利权)人(译)	半导体能源研究所有限公司.		
[标]发明人	TOYOTAKA KOUHEI MIYAKE HIROYUKI ARASAWA RYO KUSUNOKI KOJI MURAKAWA TSUTOMU		
发明人	TOYOTAKA, KOUHEI MIYAKE, HIROYUKI ARASAWA, RYO KUSUNOKI, KOJI MURAKAWA, TSUTOMU		
IPC分类号	G09G3/36		
CPC分类号	G09G3/3648 G09G3/3688 G09G3/36 G09G3/20 G09G2330/04 G09G2320/103		
优先权	2010178132 2010-08-06 JP		
其他公开文献	US8890859		
外部链接	<a href="#">Espacenet</a> <a href="#">USPTO</a>		

摘要(译)

本发明提供一种液晶显示装置，其具有包括晶体管和液晶元件的像素，以及通过数据线电连接到晶体管的源极和漏极之一的保护电路。保护电路包括提供有第一电源电位的第一端子和提供有高于第一电源电位的第二电源电位的第二端子。在运动图像显示模式中，图像信号通过晶体管从数据线输入到液晶元件，并且第一电源电位设置在第一电位。在静止图像显示模式中，停止提供图像信号，并且将第一电源电位设置为第二电位。第二电位与图像信号的最小值基本相同。

