



US009835915B2

(12) **United States Patent**  
**Kim et al.**

(10) **Patent No.:** **US 9,835,915 B2**  
(45) **Date of Patent:** **Dec. 5, 2017**

(54) **LIQUID CRYSTAL DISPLAY**

(56) **References Cited**

(75) Inventors: **Sung-Hoon Kim**, Seoul (KR); **Joo Seok Yeom**, Seoul (KR); **Kyu Wan Ryu**, Seoul (KR); **Jeong Soo Choi**, Suwon-si (KR)  
(73) Assignee: **Samsung Display Co., Ltd.**, Yongin-si (KR)  
(\* ) Notice: Subject to any disclaimer, the term of this patent is extended or adjusted under 35 U.S.C. 154(b) by 691 days.

U.S. PATENT DOCUMENTS

7,663,724 B2 2/2010 Lim et al.  
2002/0159016 A1\* 10/2002 Nishida ..... G02F 1/134363  
349/141  
2004/0105051 A1 6/2004 Chuang et al.  
2006/0001803 A1\* 1/2006 Park ..... G02F 1/13439  
349/113  
2006/0285046 A1 12/2006 Yang et al.  
2008/0186440 A1 8/2008 Lim et al.  
2009/0323005 A1 12/2009 Ota  
2010/0123866 A1 5/2010 Chang et al.  
2010/0245733 A1\* 9/2010 Ono ..... G02F 1/13394  
349/106  
2011/0001910 A1\* 1/2011 Fujiyoshi ..... G02F 1/13394  
349/106  
2011/0037931 A1 2/2011 Im et al.  
(Continued)

(21) Appl. No.: **13/558,156**  
(22) Filed: **Jul. 25, 2012**

(65) **Prior Publication Data**  
US 2013/0077008 A1 Mar. 28, 2013

FOREIGN PATENT DOCUMENTS

CN 1696769 11/2005  
CN 101093329 12/2007  
(Continued)

(30) **Foreign Application Priority Data**  
Sep. 23, 2011 (KR) ..... 10-2011-0096523

OTHER PUBLICATIONS

European Patent Office, Extended European Search Report for Application No. 12185681.9-2205, dated Jan. 7, 2013.

(51) **Int. Cl.**  
**G02F 1/1343** (2006.01)  
**G02F 1/1362** (2006.01)  
(52) **U.S. Cl.**  
CPC .. **G02F 1/136227** (2013.01); **G02F 1/136209** (2013.01); **G02F 2001/134372** (2013.01); **G02F 2001/136222** (2013.01); **G02F 2201/40** (2013.01); **G02F 2201/52** (2013.01)

*Primary Examiner* — Charles Chang  
(74) *Attorney, Agent, or Firm* — H.C. Park & Associates, PLC

(58) **Field of Classification Search**  
CPC ..... G02F 1/136; G02F 1/136227; G02F 1/136209; G02F 2001/134372; G02F 2001/136222; G02F 2201/40; G02F 2201/52  
USPC ..... 349/141  
See application file for complete search history.

(57) **ABSTRACT**  
A liquid crystal display in which the common voltage line is disposed directly on or directly under the common electrode such that a signal delay of the common voltage line may be reduced and simultaneously a reduction in the aperture ratio of the liquid crystal display may be prevented.

**29 Claims, 51 Drawing Sheets**

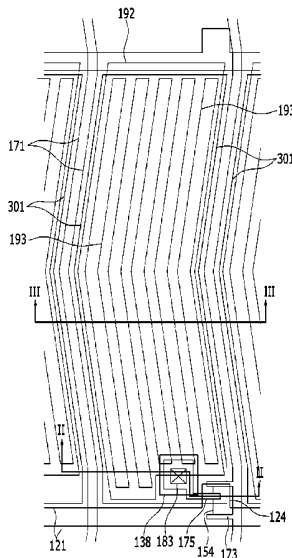

(56) **References Cited**

U.S. PATENT DOCUMENTS

2011/0050551 A1\* 3/2011 Ota ..... G02F 1/134363  
345/87  
2012/0112200 A1\* 5/2012 Nagano ..... G02F 1/134363  
257/72  
2012/0154730 A1\* 6/2012 Sakurai ..... G02F 1/134363  
349/141

FOREIGN PATENT DOCUMENTS

CN 101165576 4/2008  
CN 101248388 8/2008  
CN 101419368 4/2009  
CN 101424804 5/2009  
CN 101526704 9/2009  
CN 101738799 6/2010  
CN 102023438 4/2011  
EP 1793266 6/2007  
JP 2001-255519 9/2001  
JP 2002-277899 9/2002  
JP 2002-323706 11/2002  
JP 2007-128112 5/2007  
JP 2008-191669 8/2008  
JP 2008310210 12/2008  
JP 2010-008758 1/2010  
JP 2010-160254 7/2010  
KR 1020060104709 10/2006  
KR 1020070002779 1/2007  
KR 1020110054727 5/2011

\* cited by examiner

FIG. 1

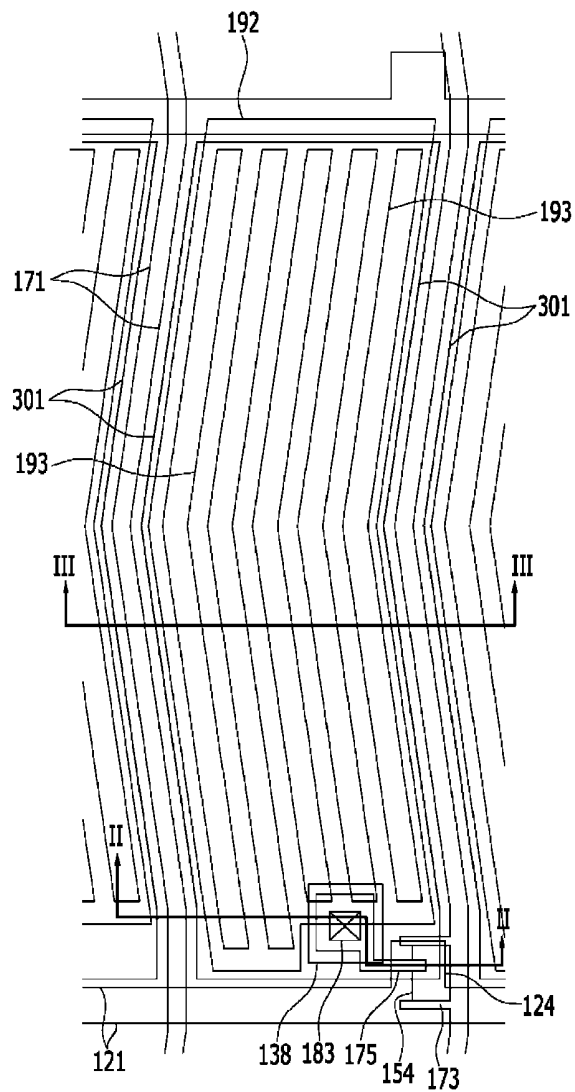

FIG. 2

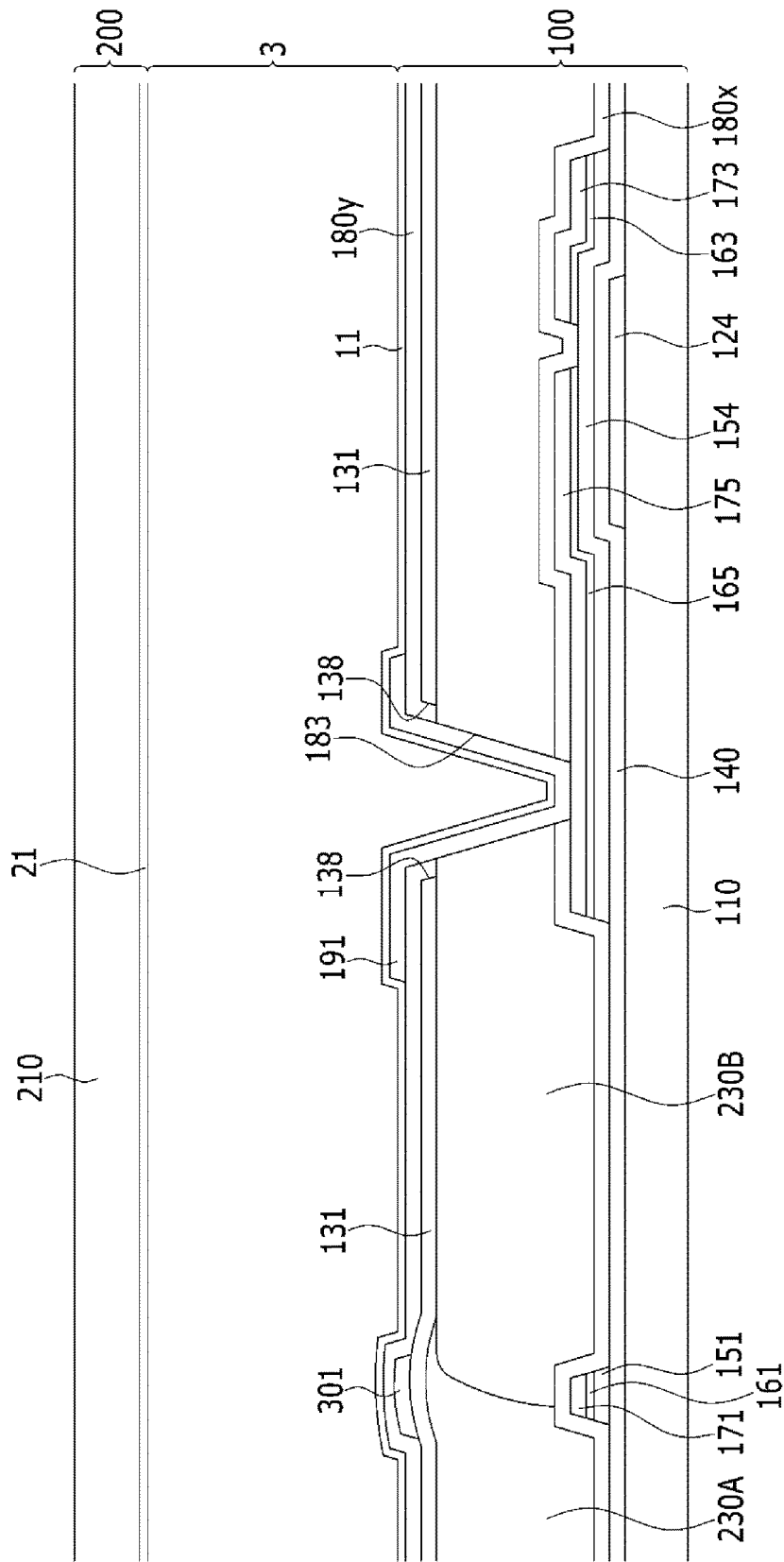

FIG. 3A

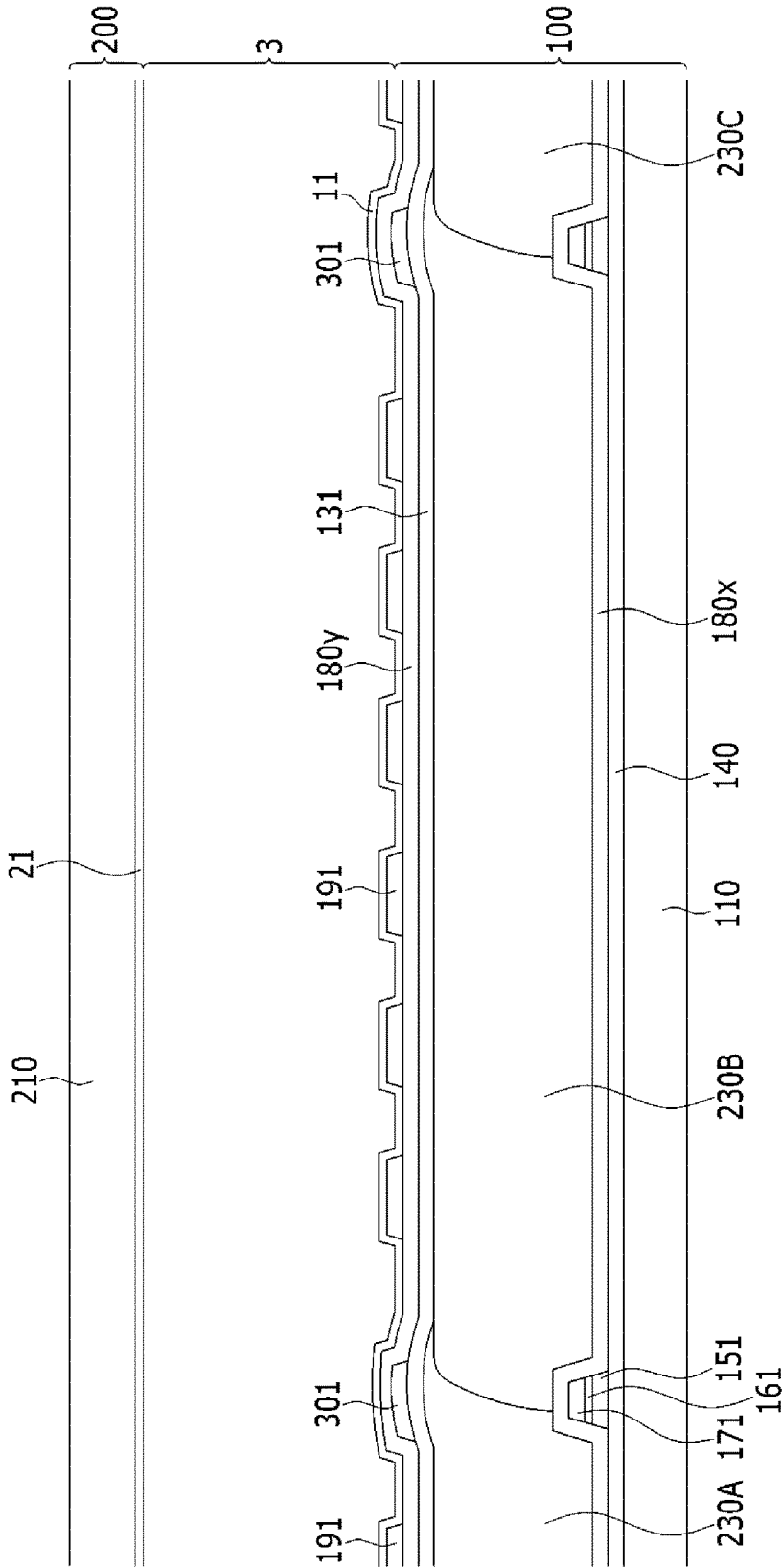

FIG. 3B

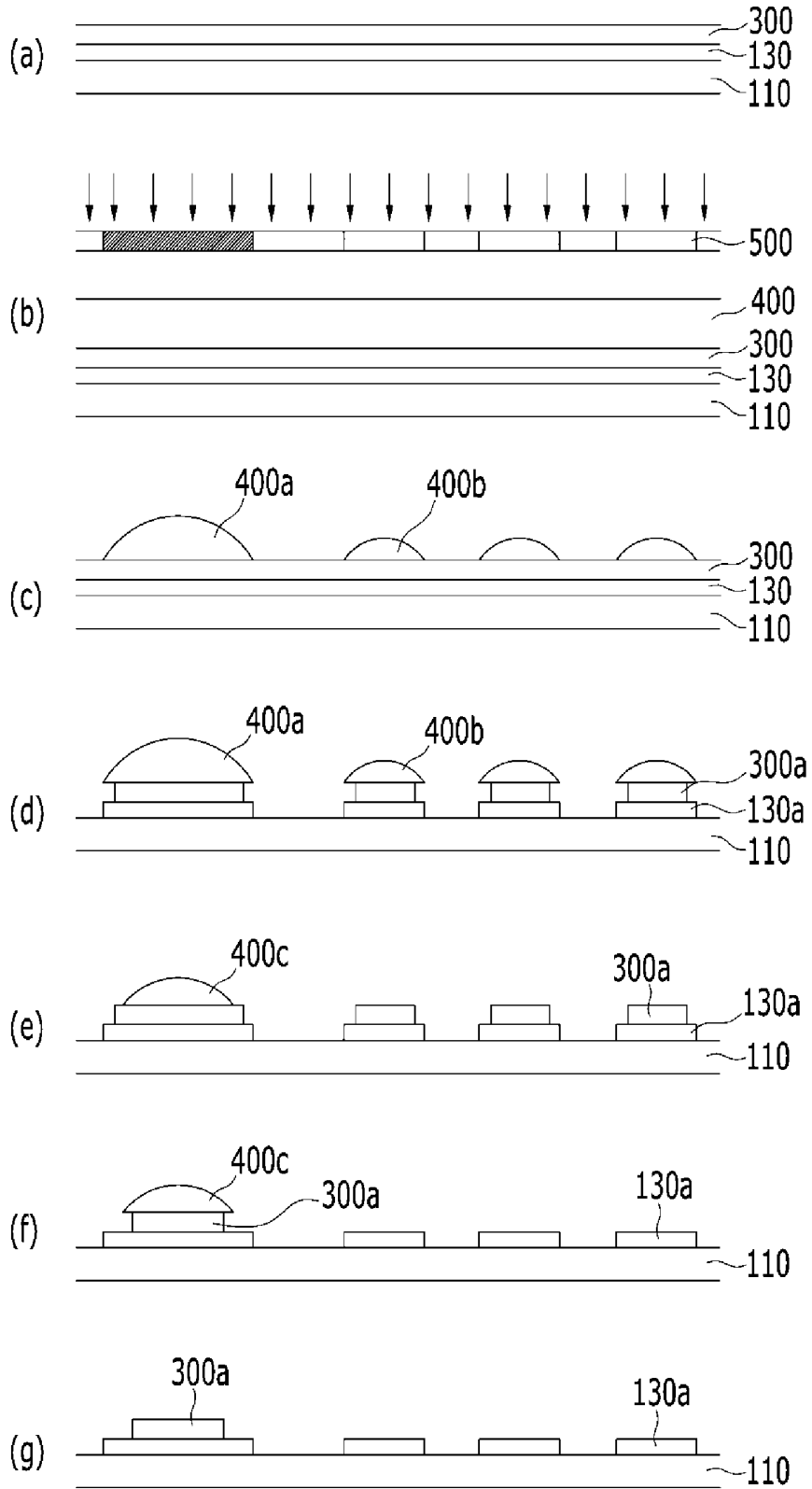

FIG. 4

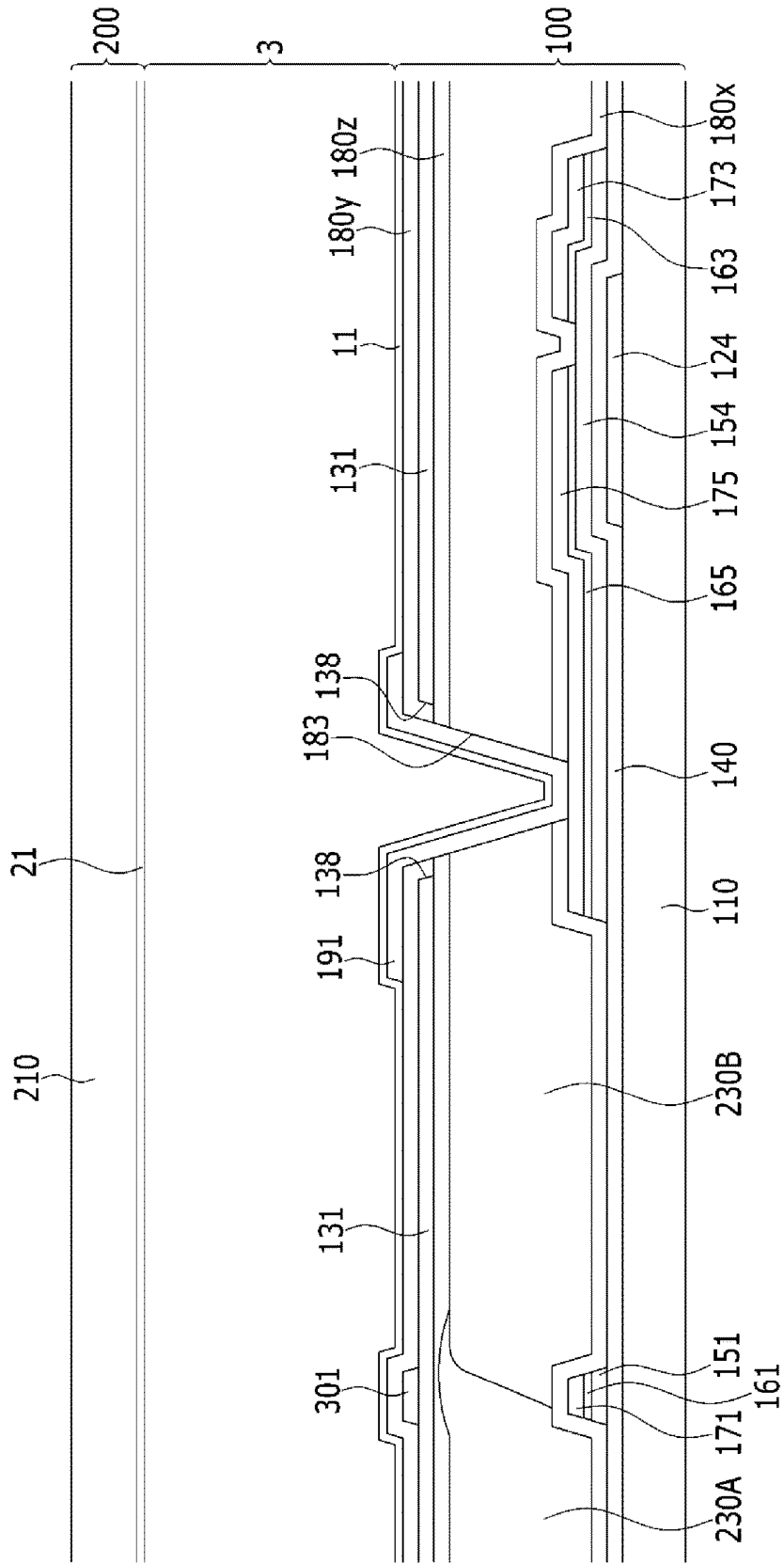

FIG. 5

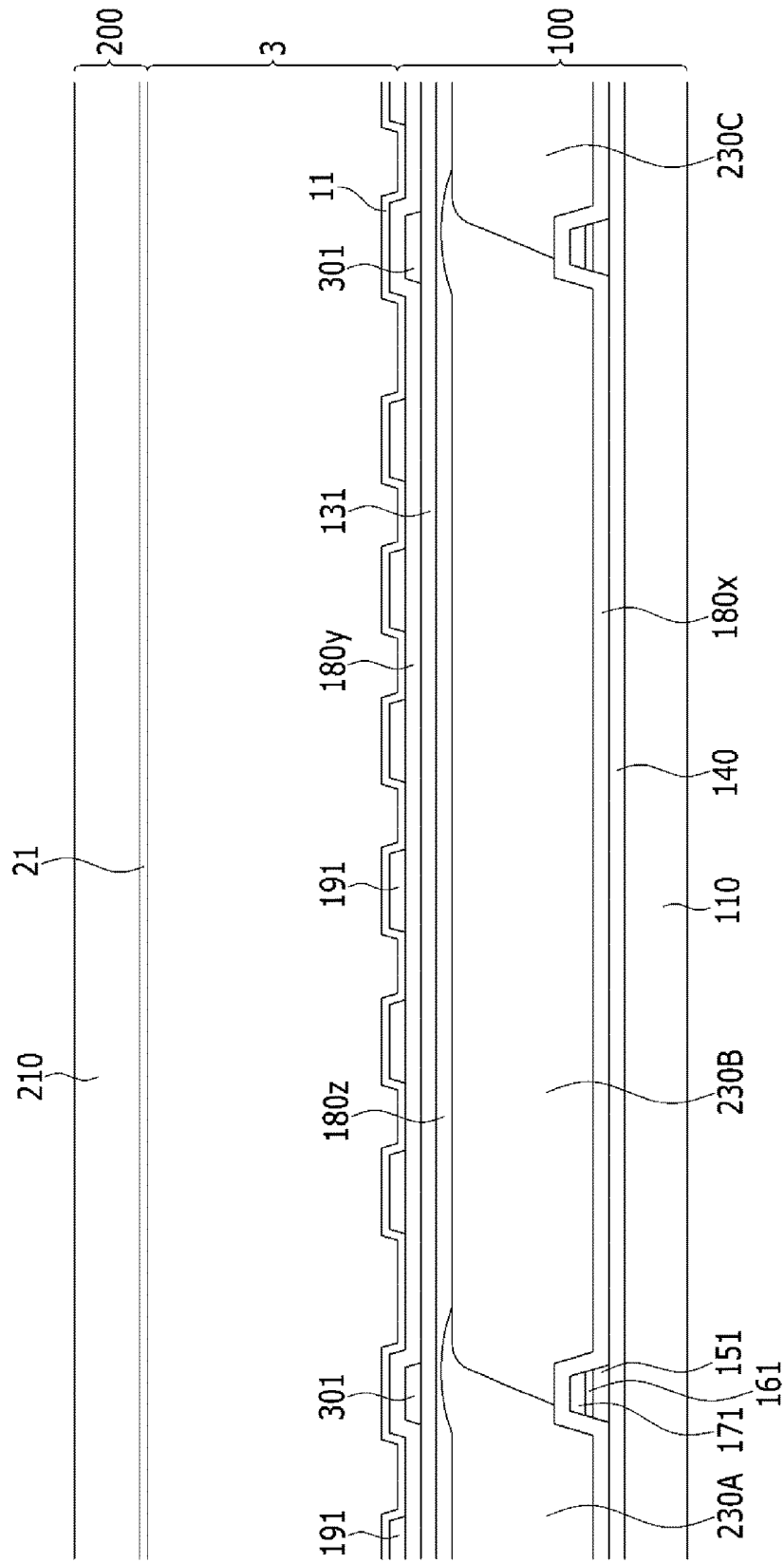

FIG. 6

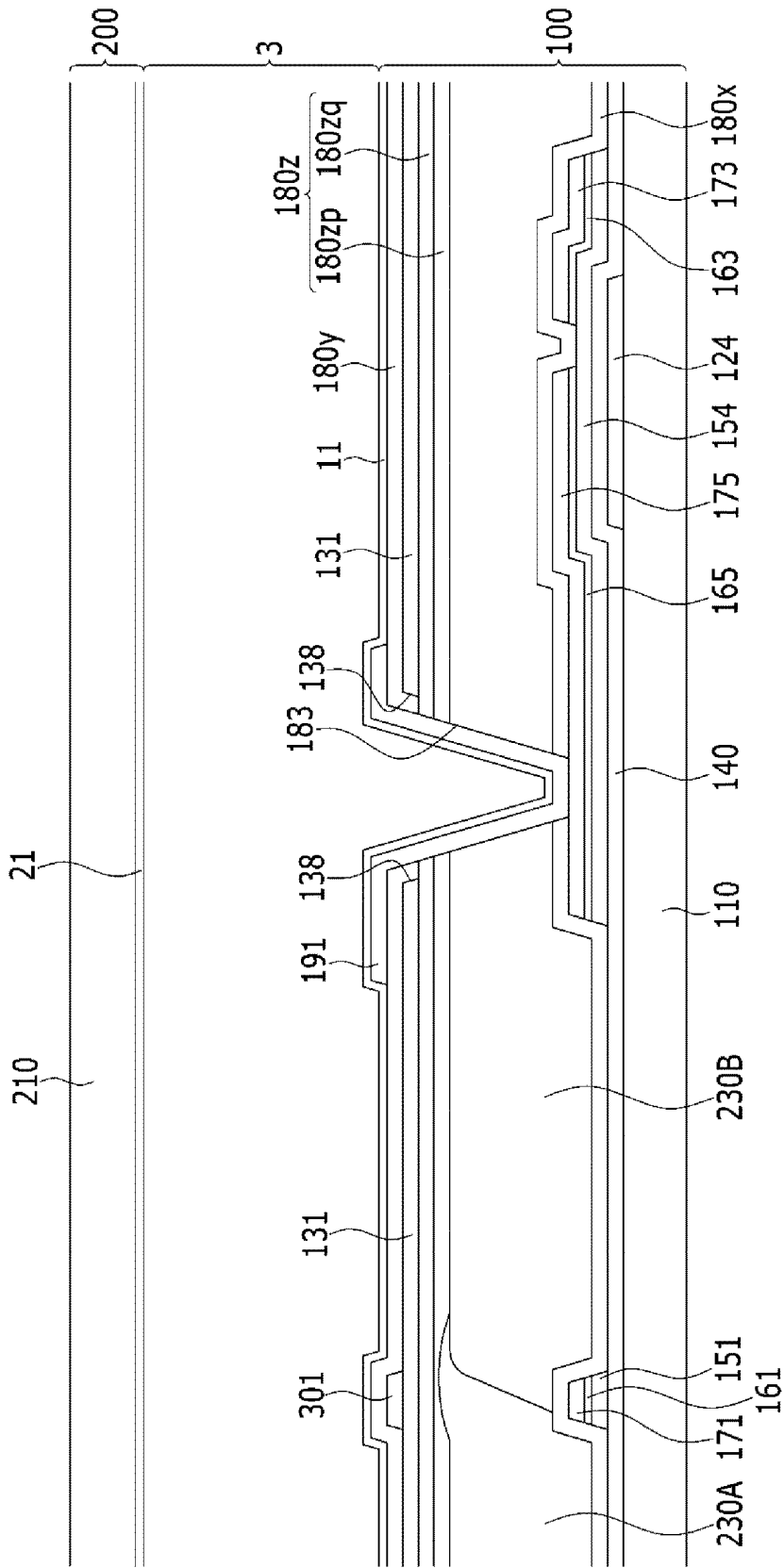

FIG. 7

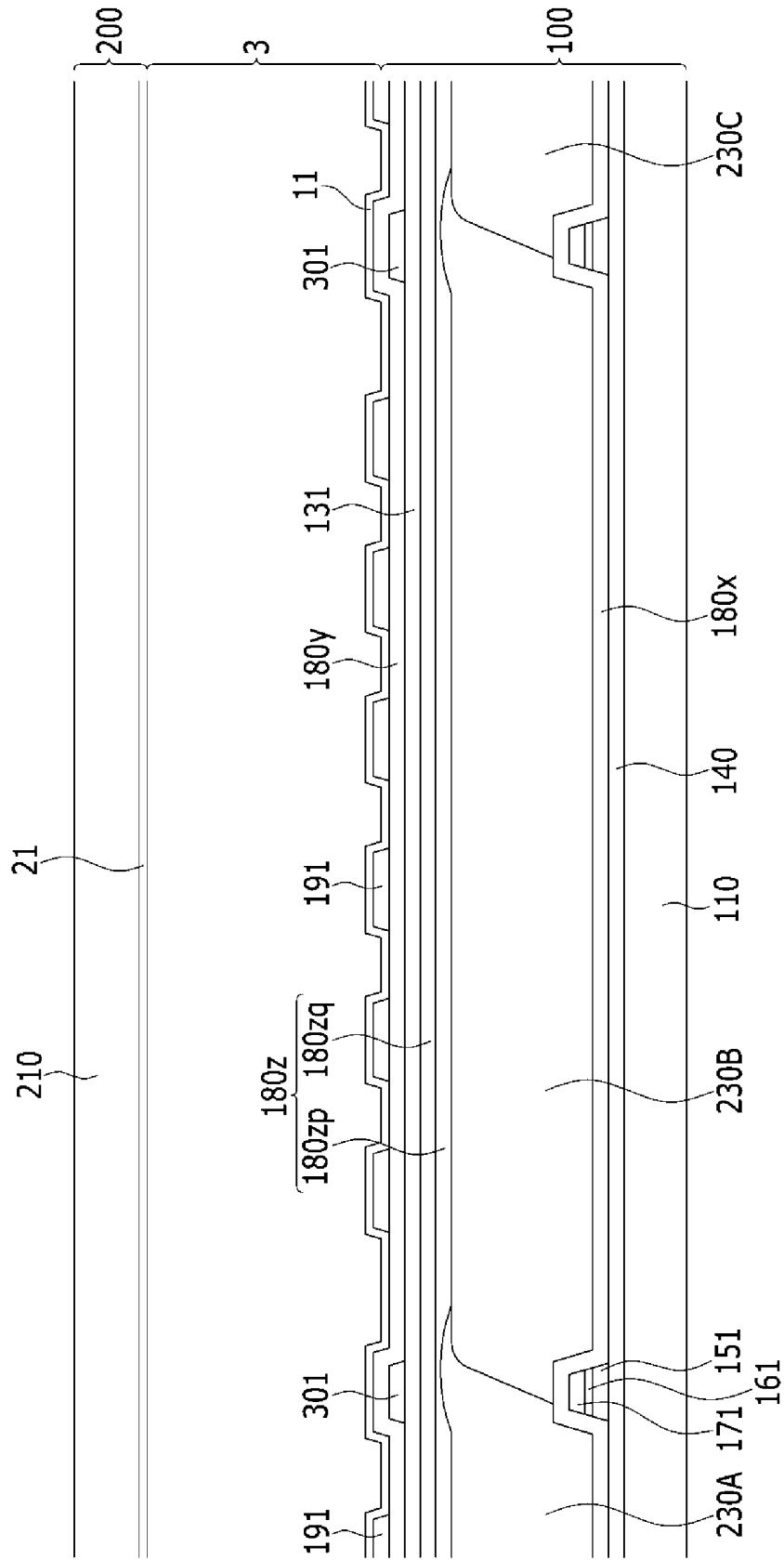

FIG. 8

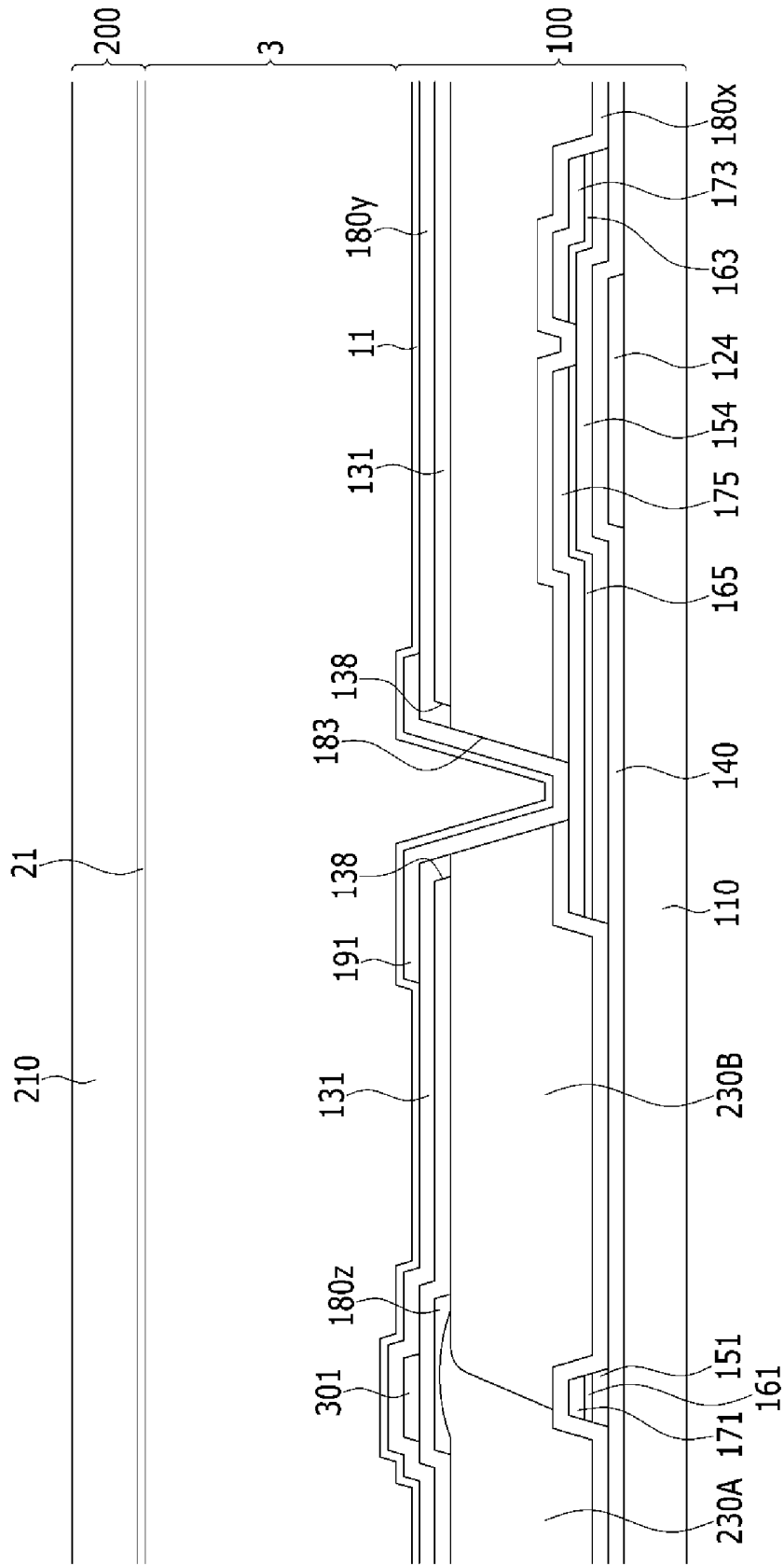

FIG. 9

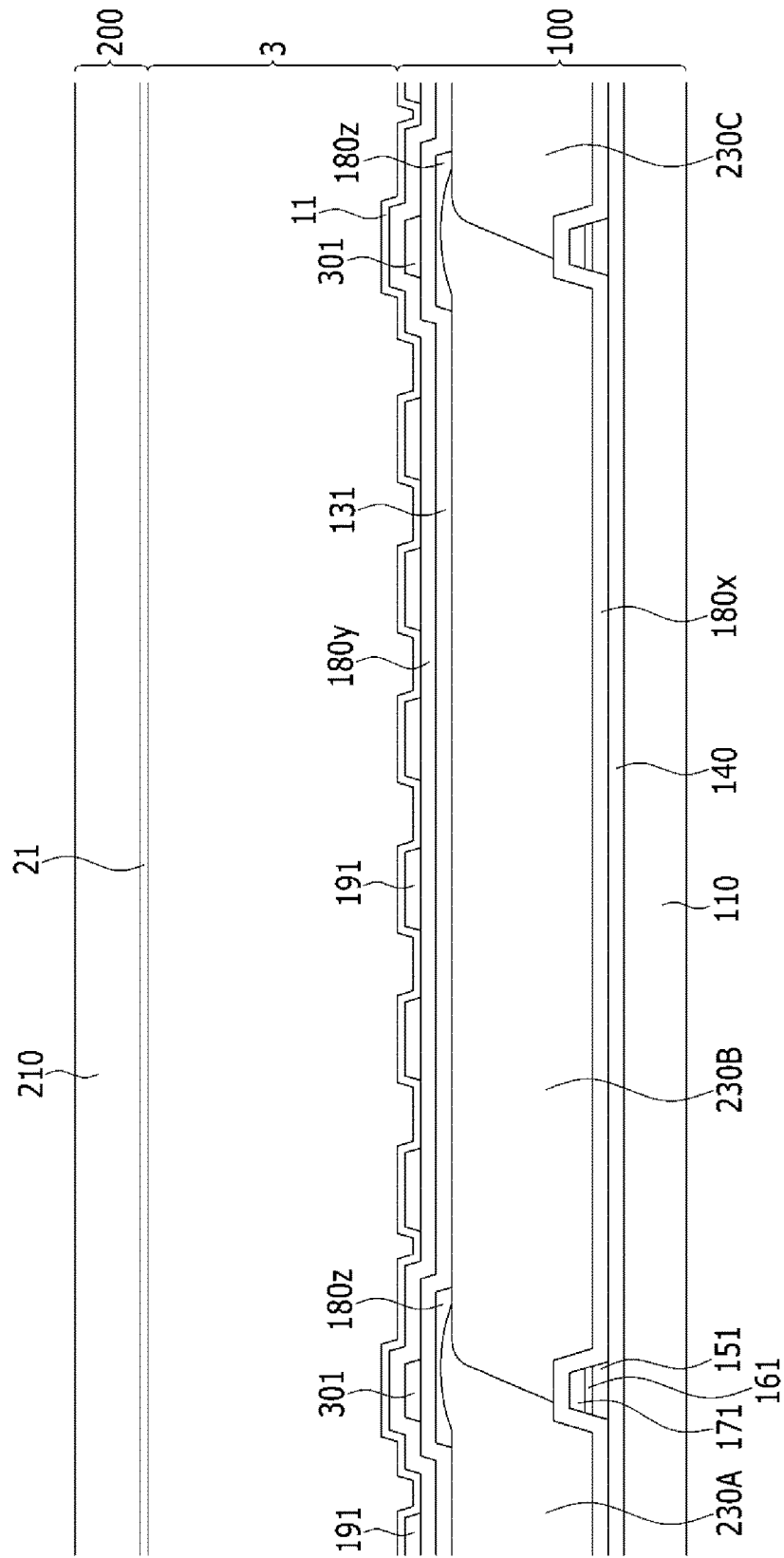

FIG. 10

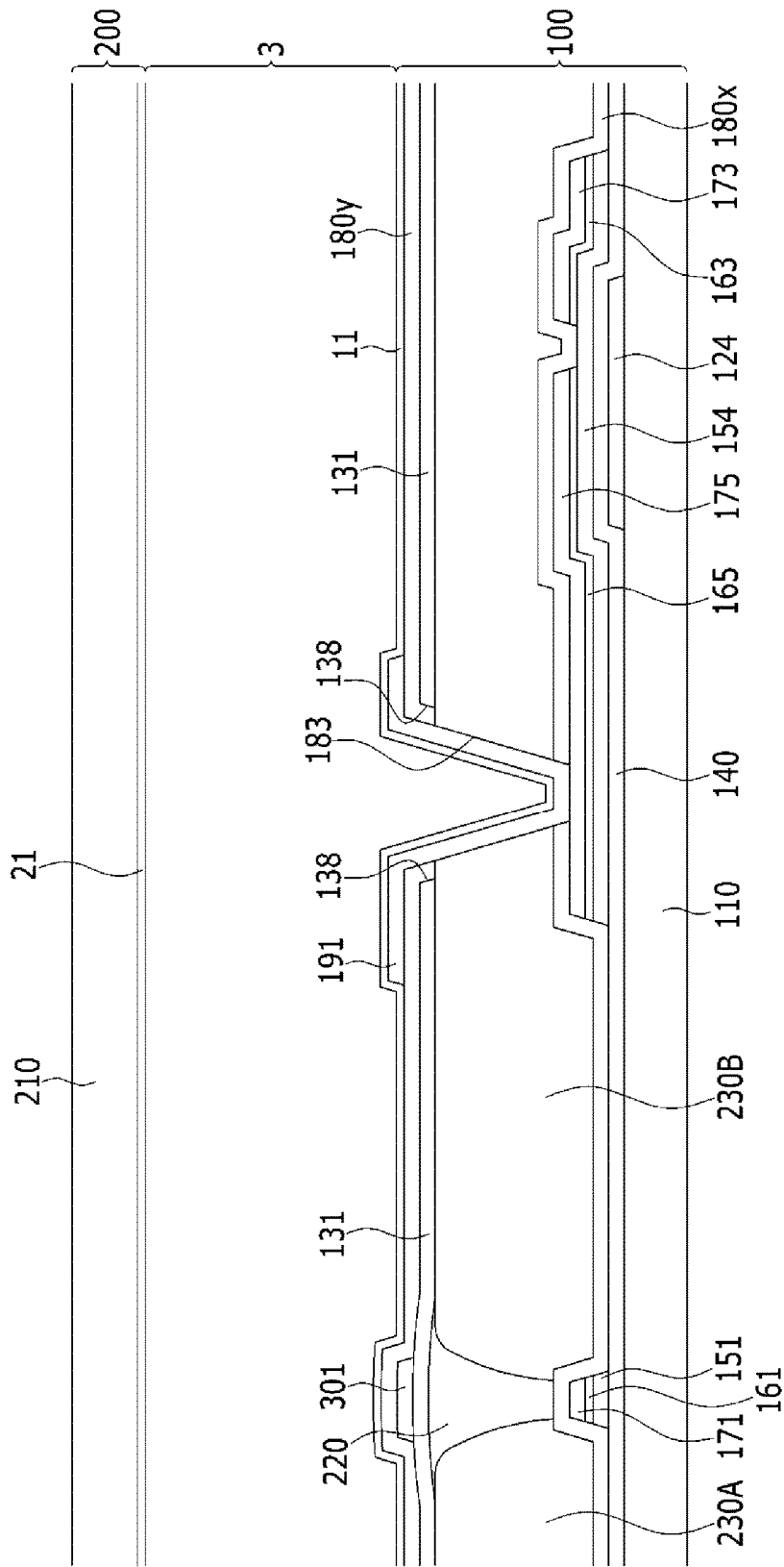

FIG. 11

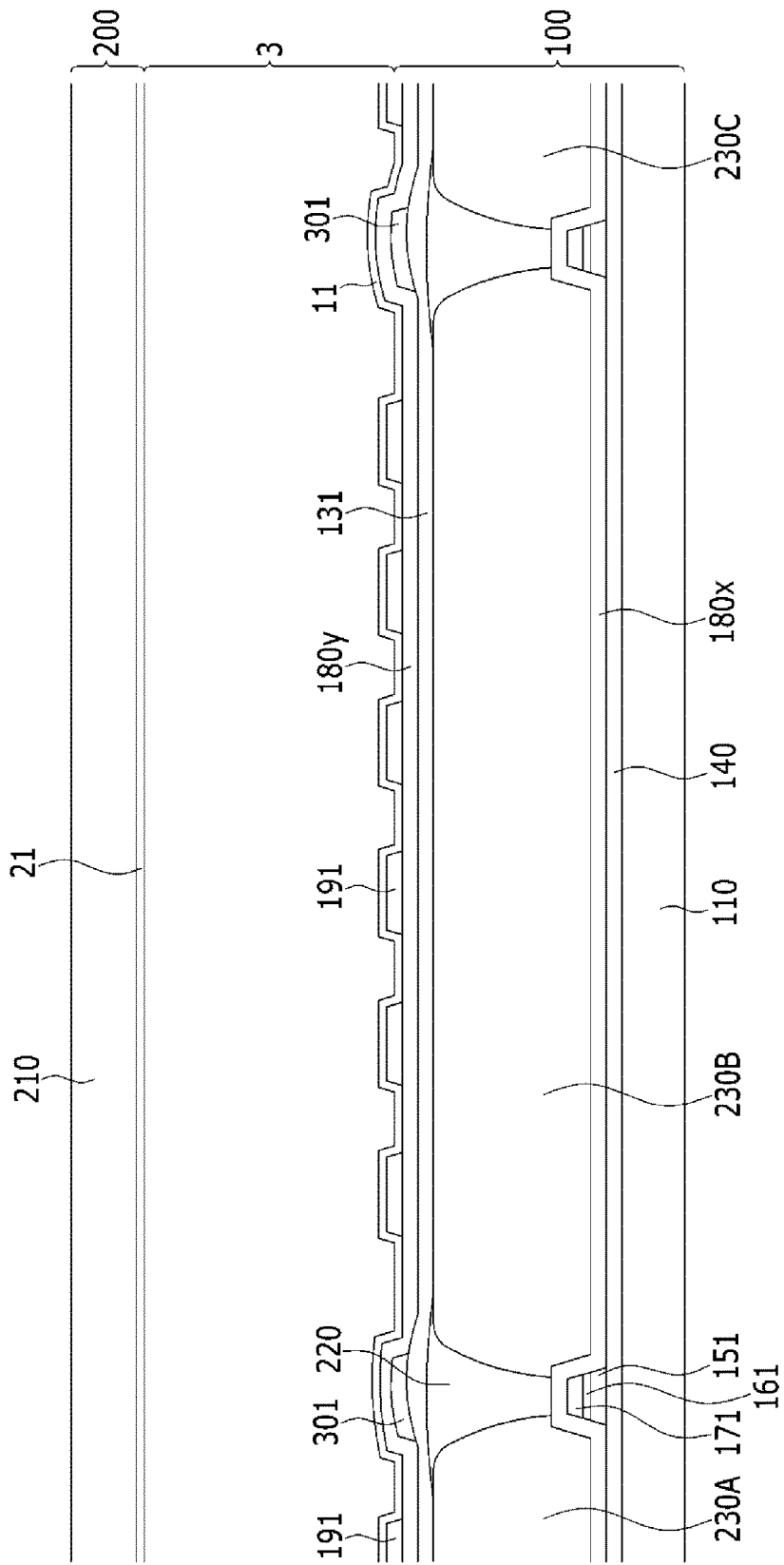

FIG. 12

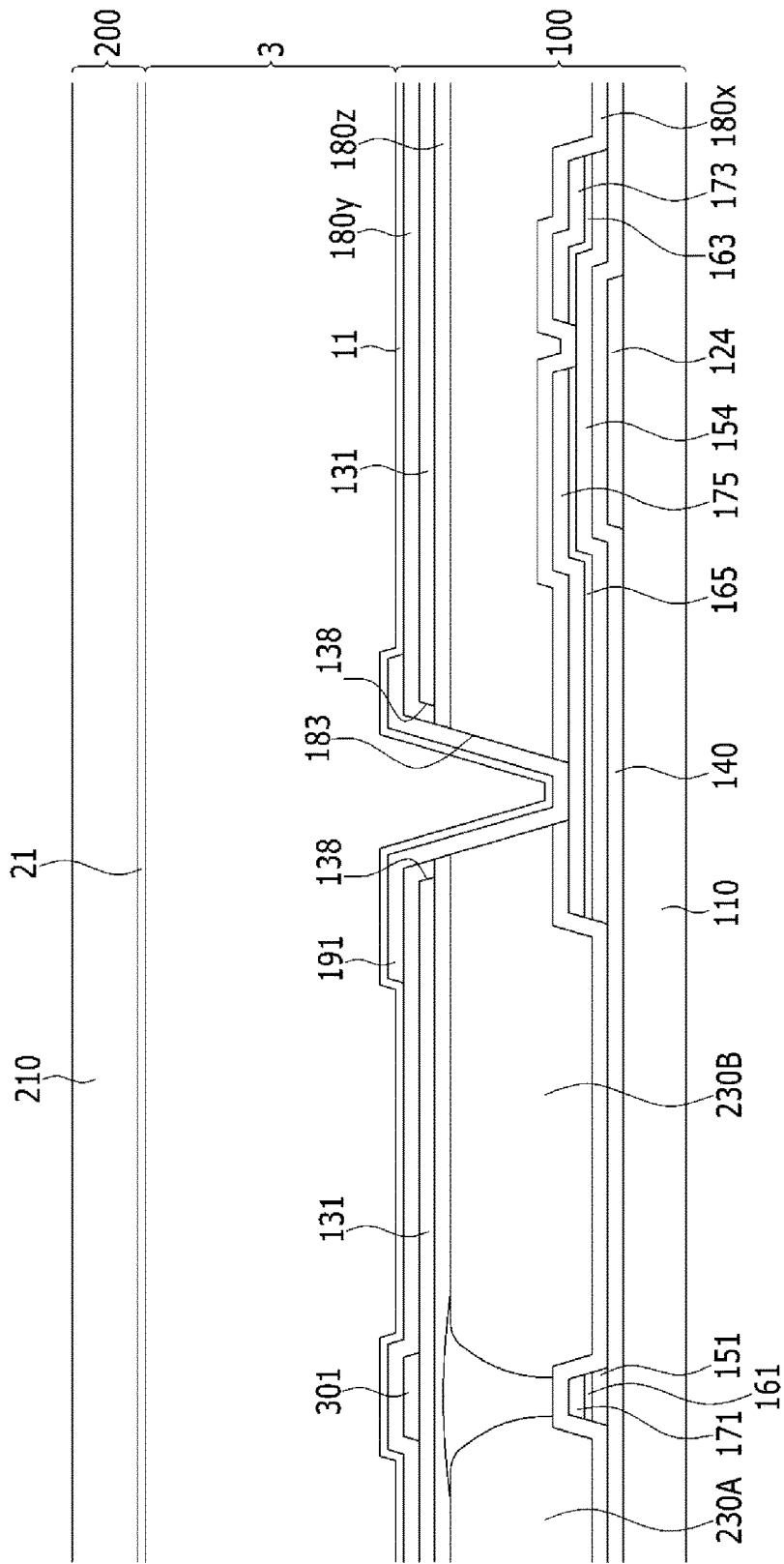



FIG. 14

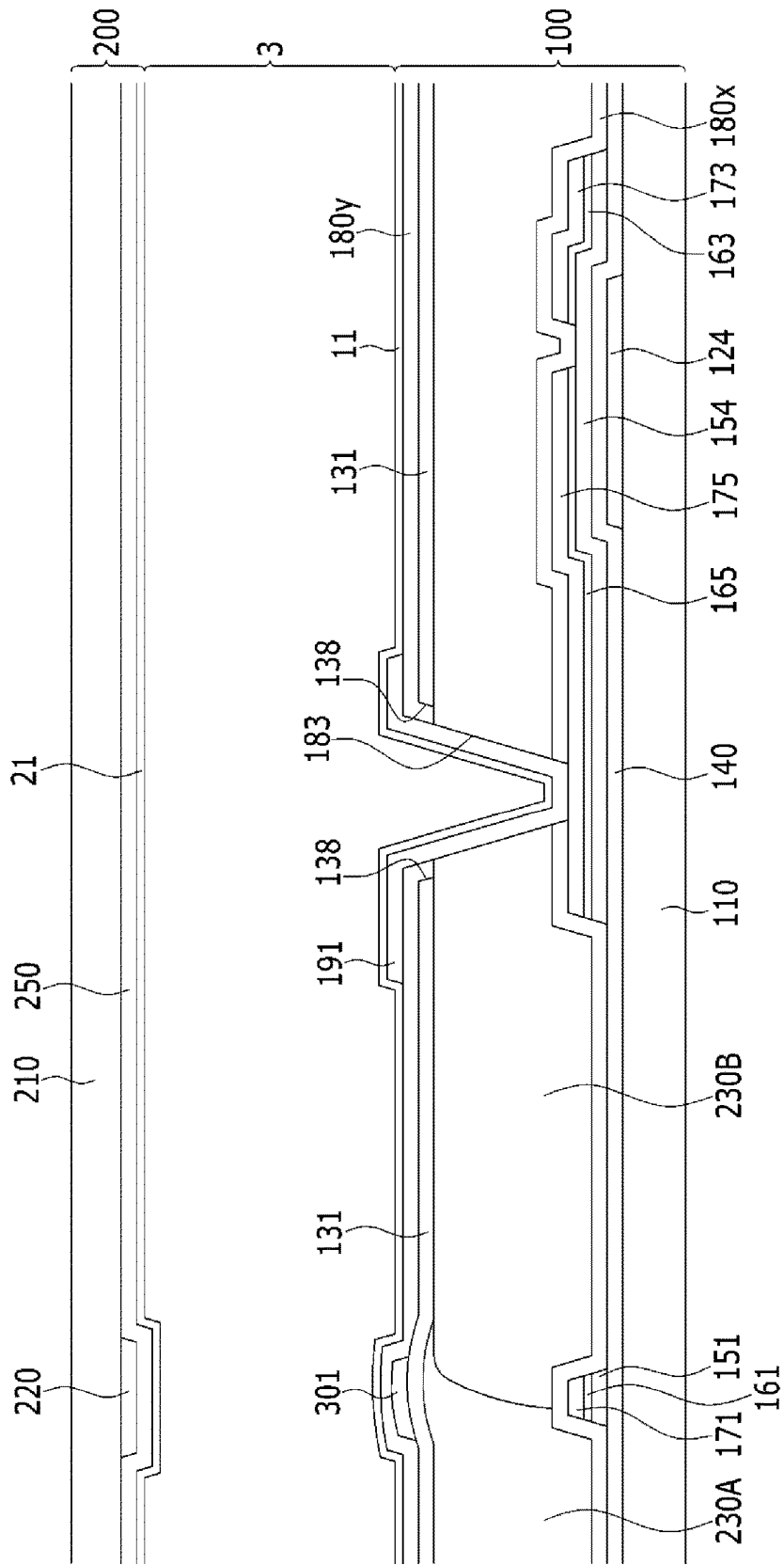

FIG. 15

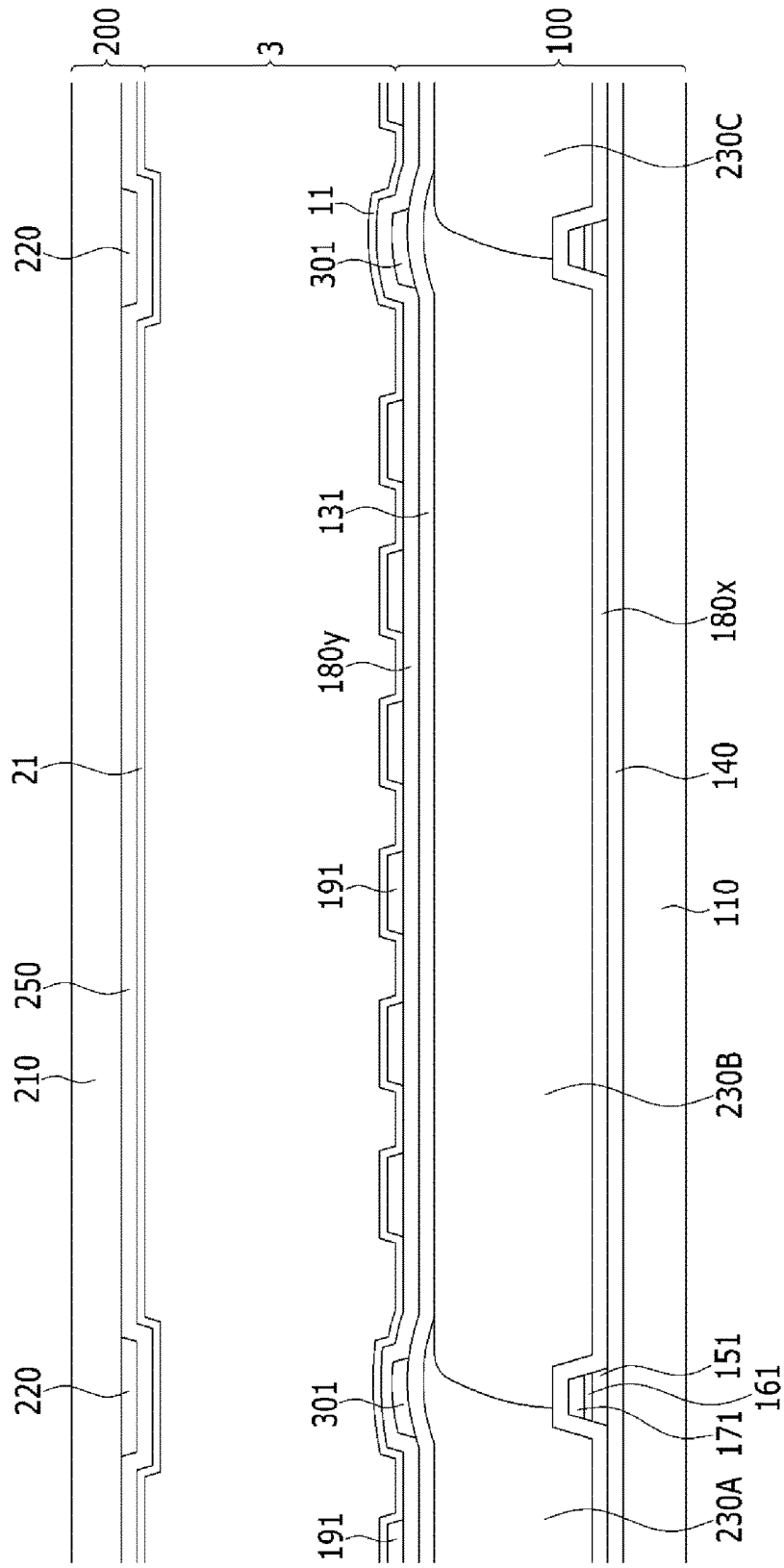

FIG. 16

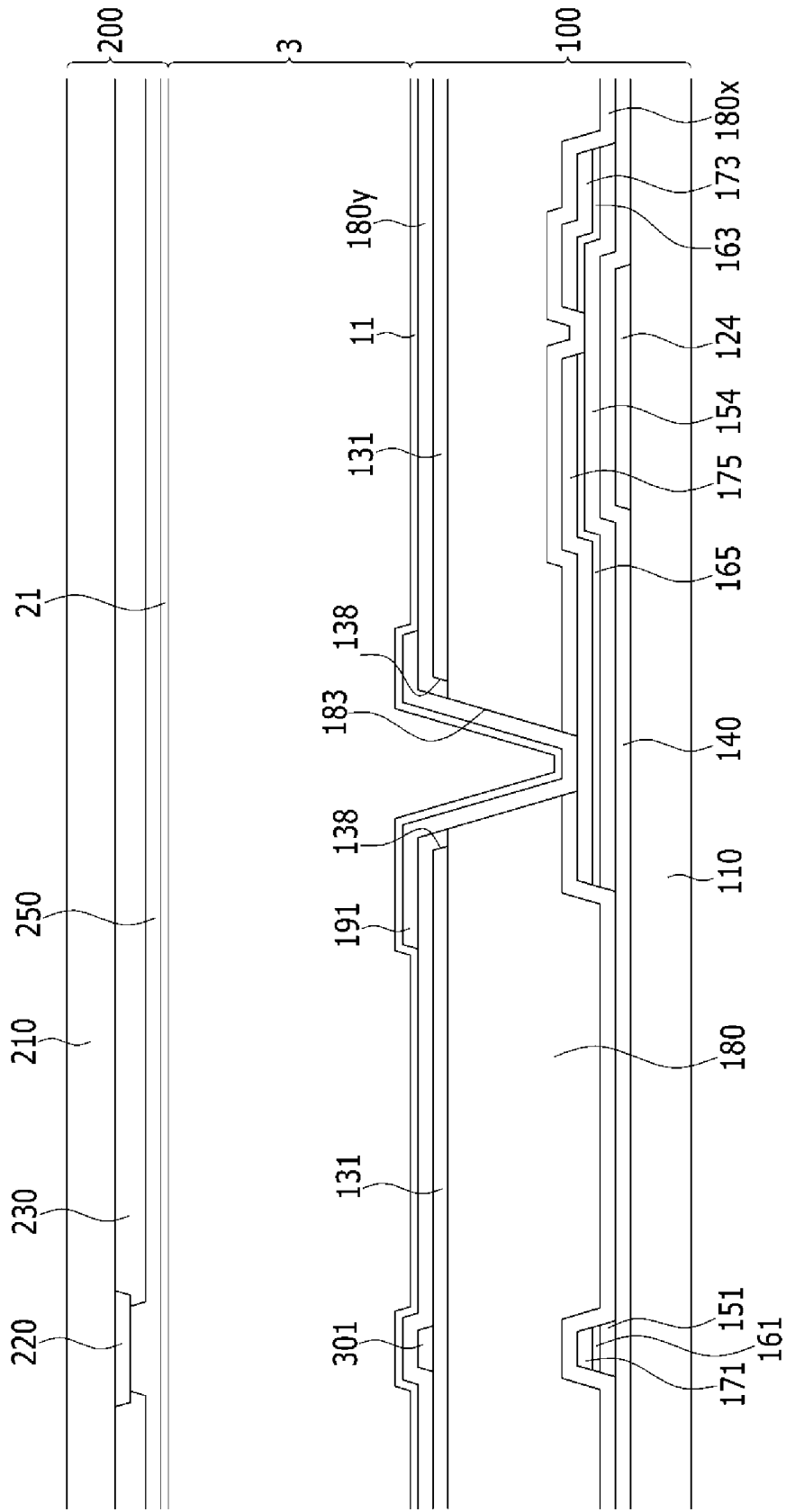

FIG. 17

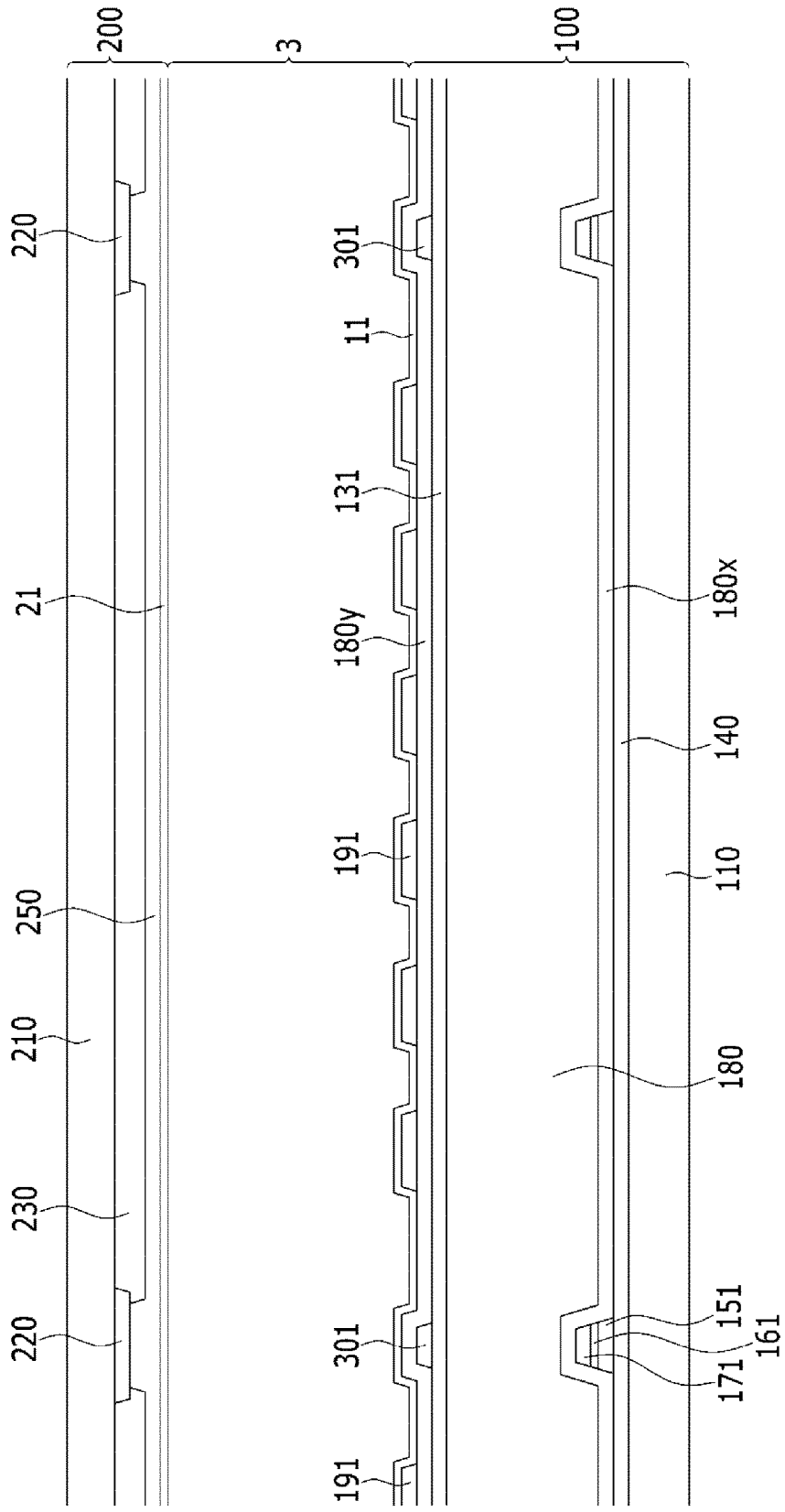

FIG. 18

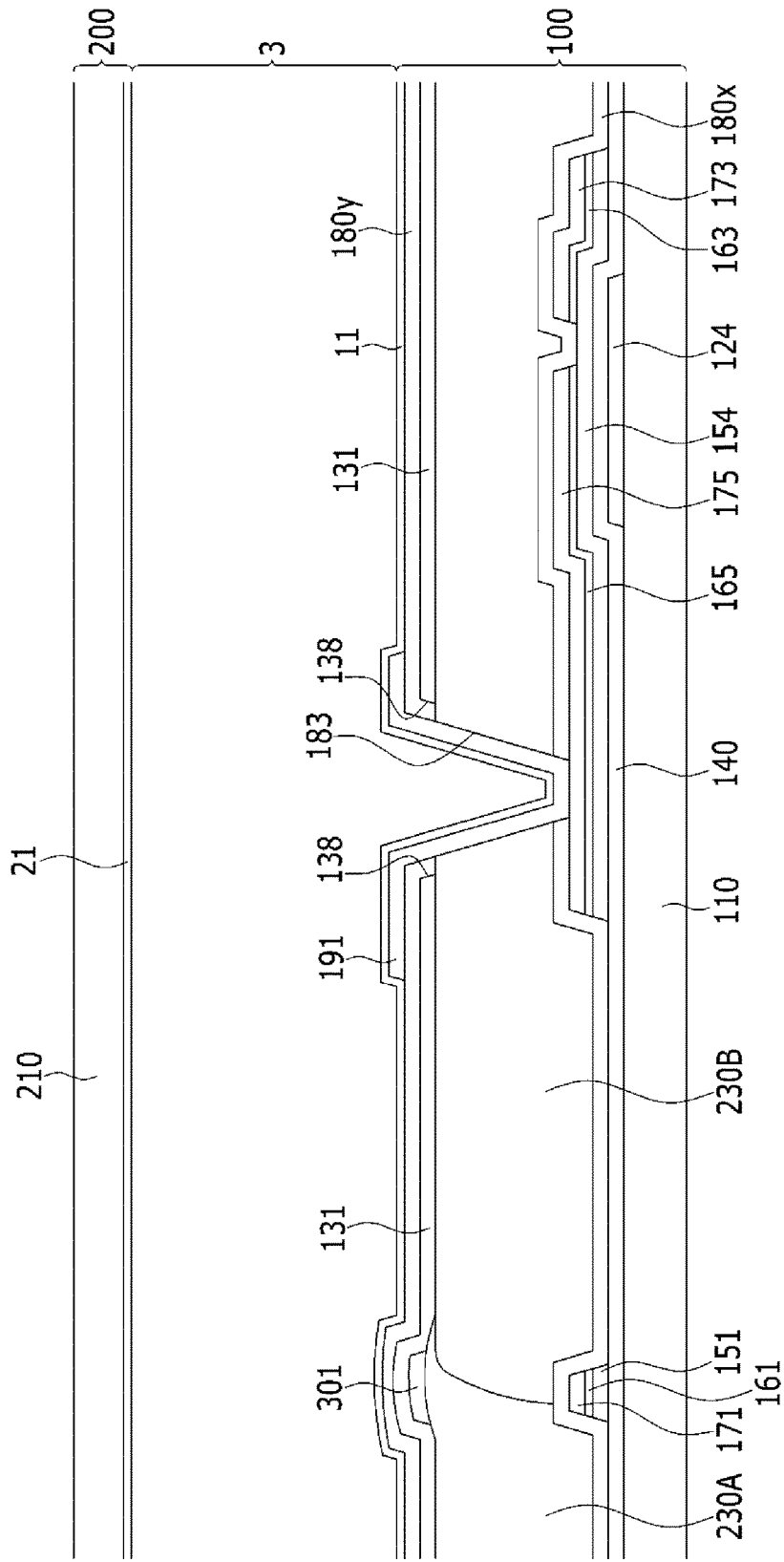

FIG. 19

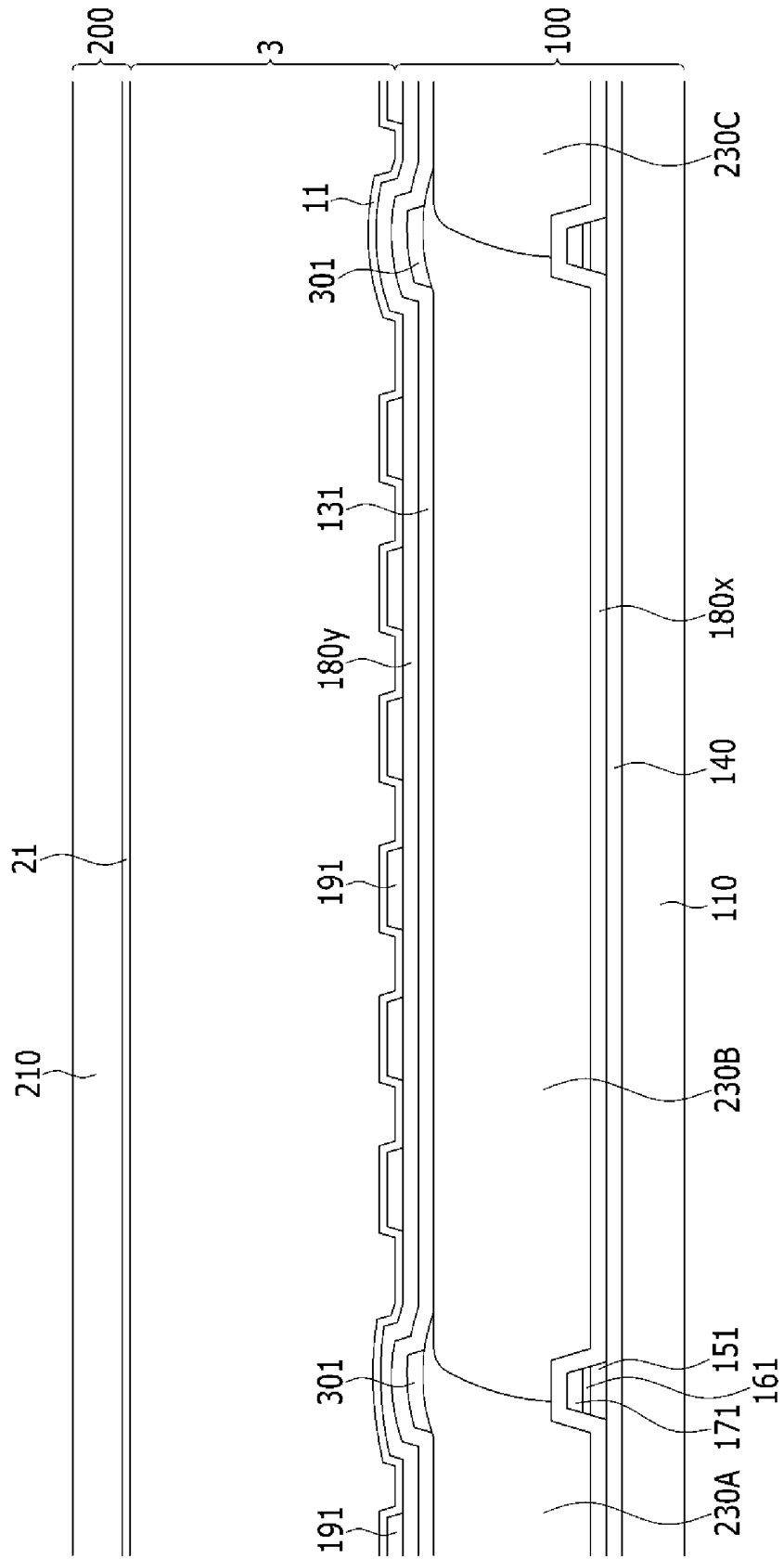

FIG. 20

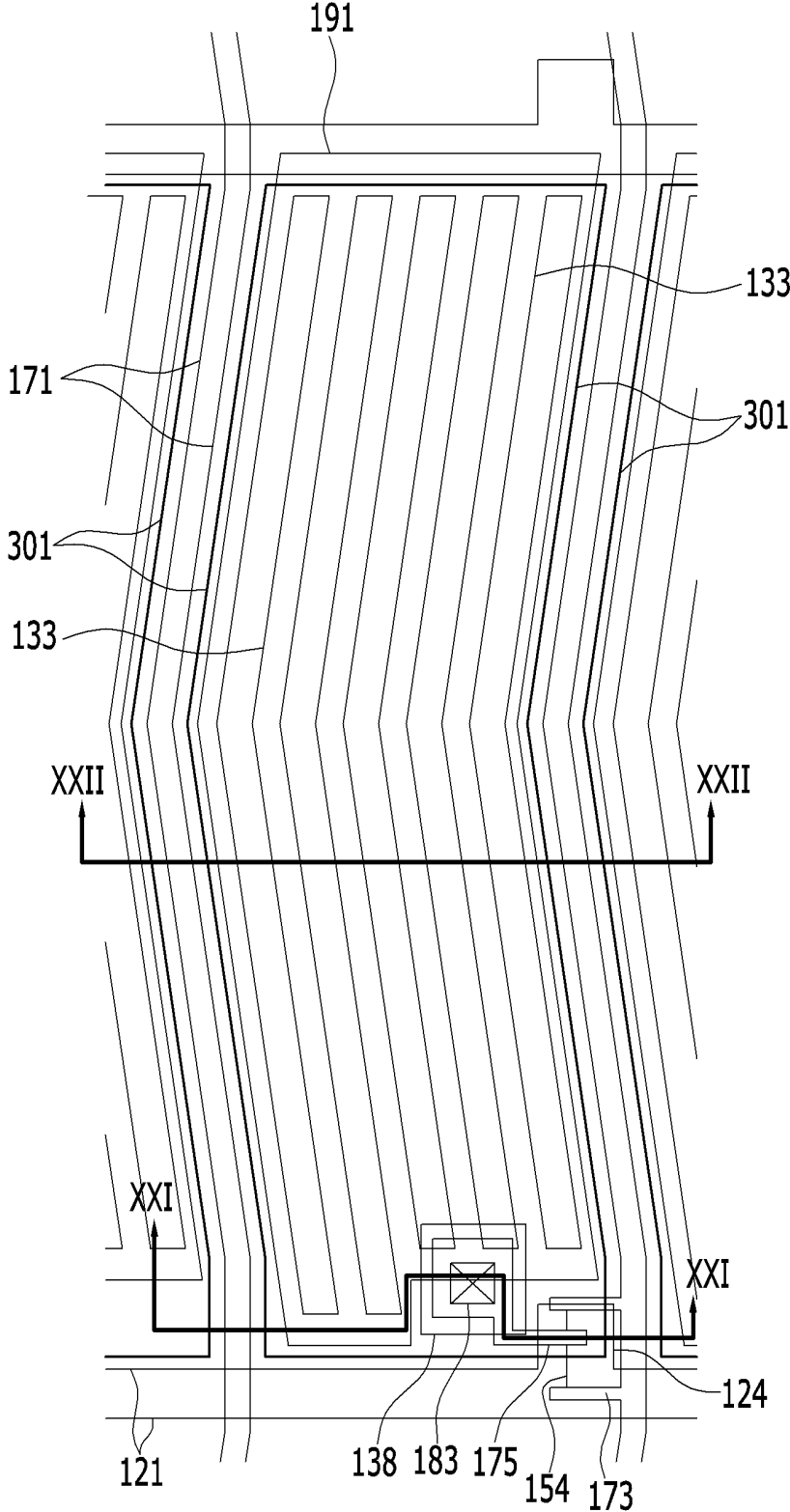

FIG. 21

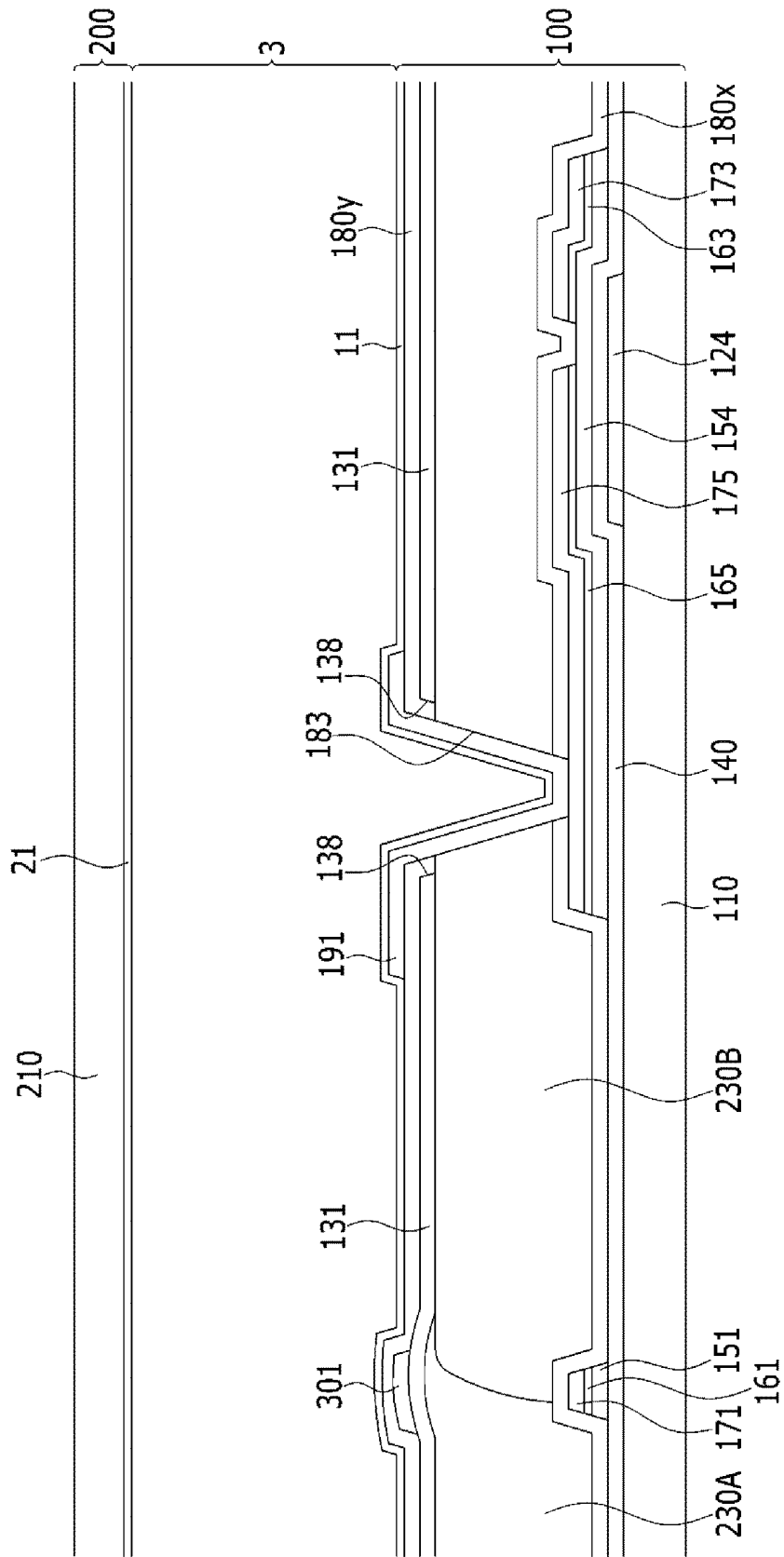

FIG. 22

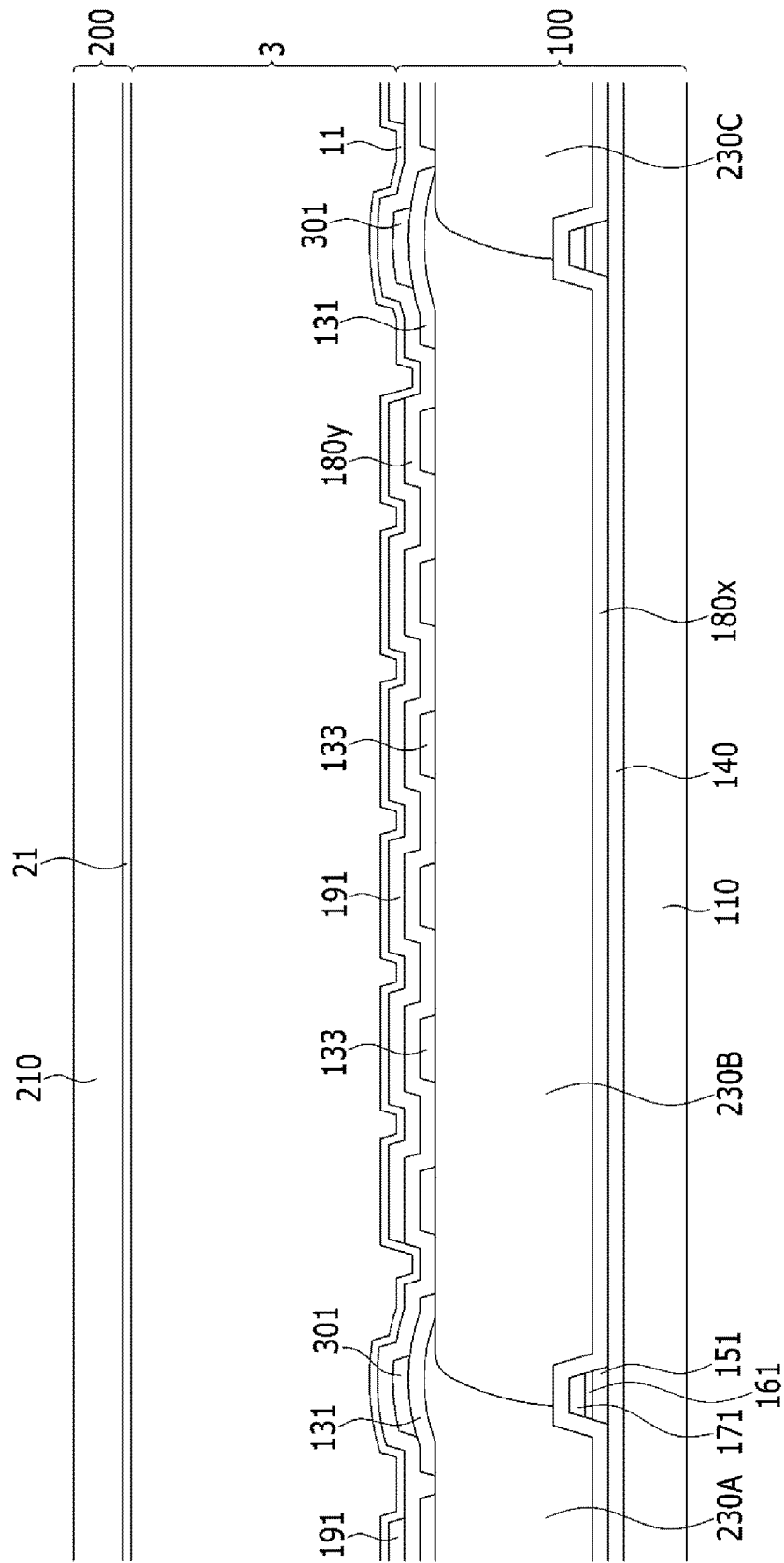

FIG. 23

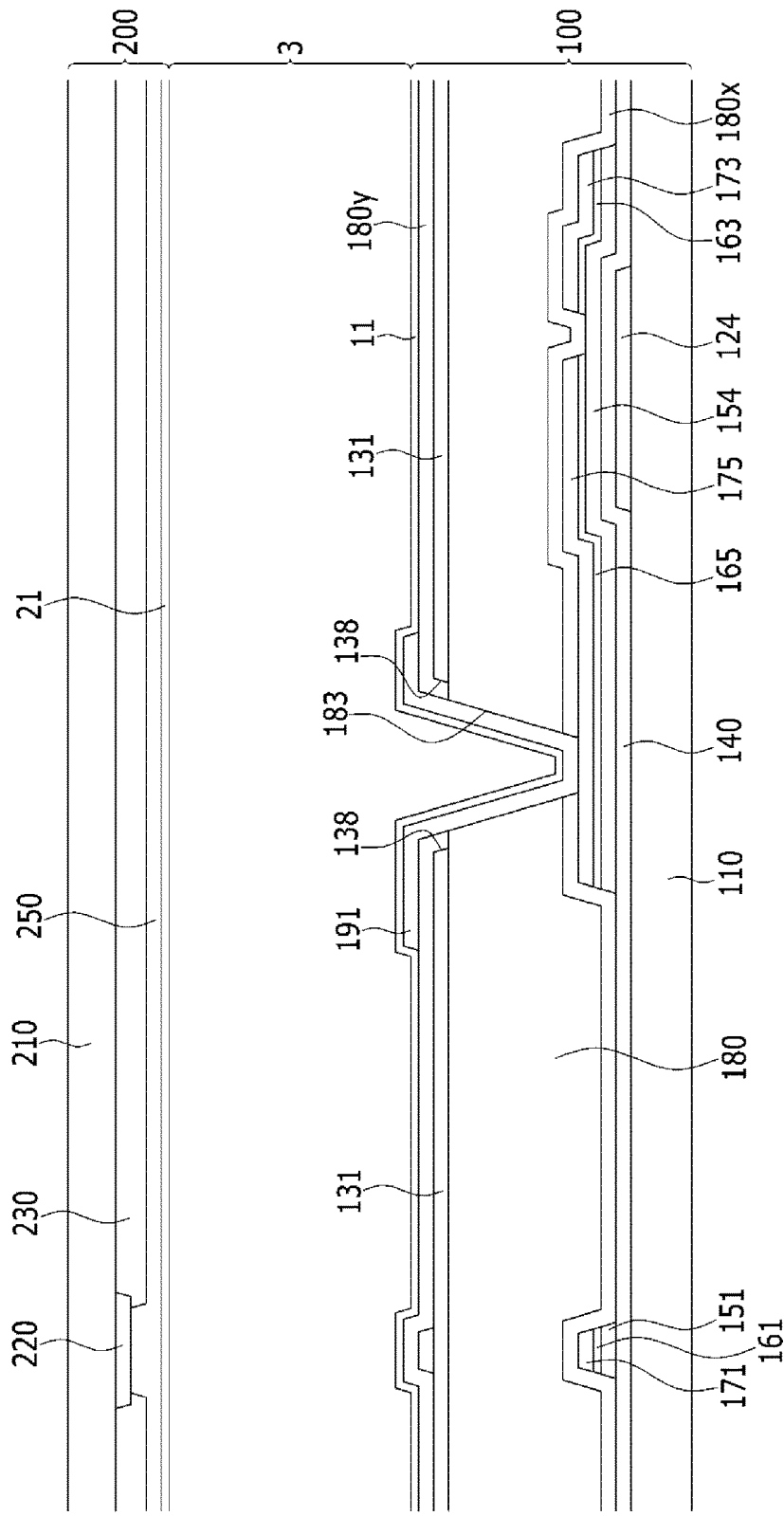

FIG. 24

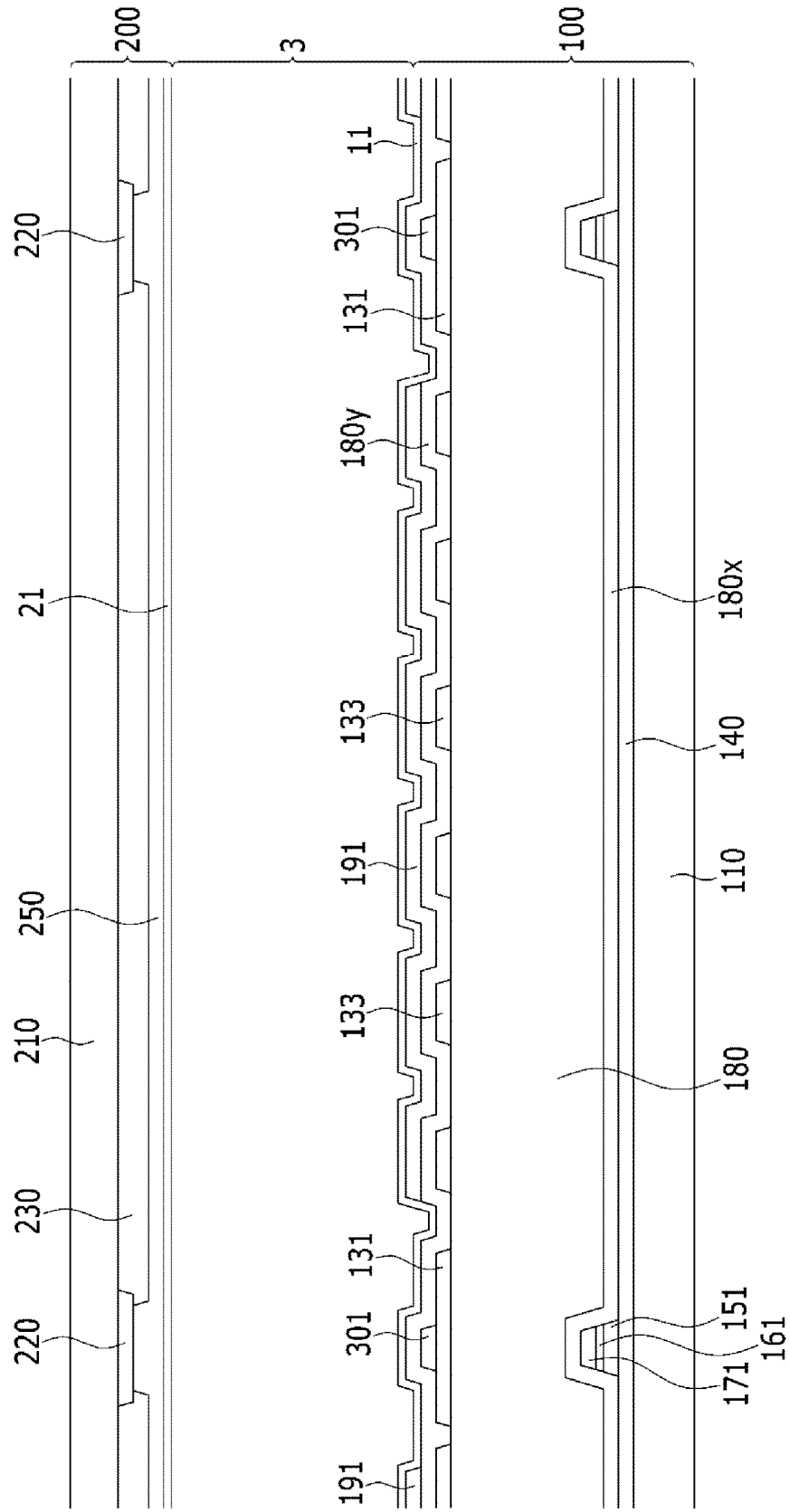

FIG. 25

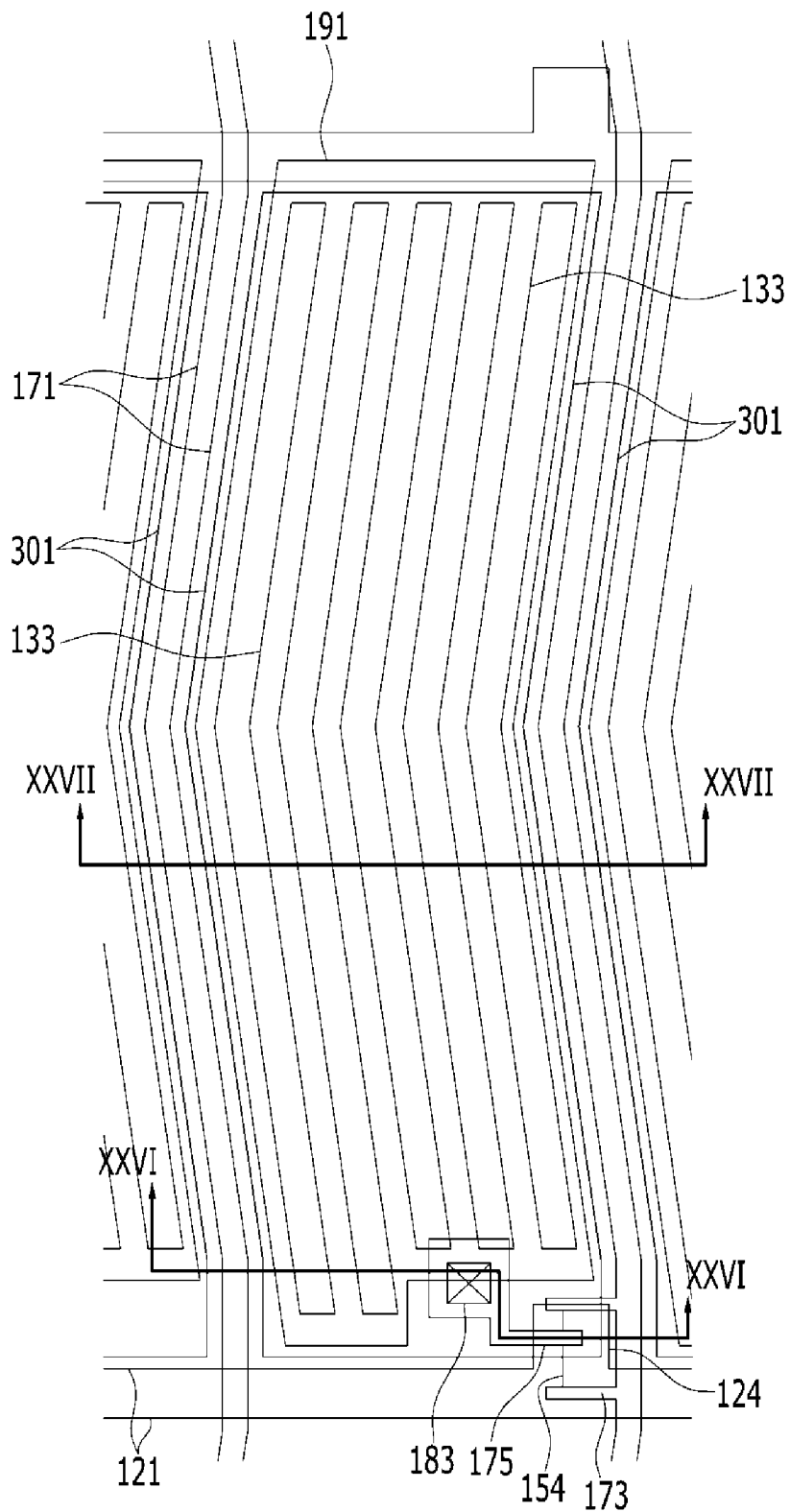

FIG. 26

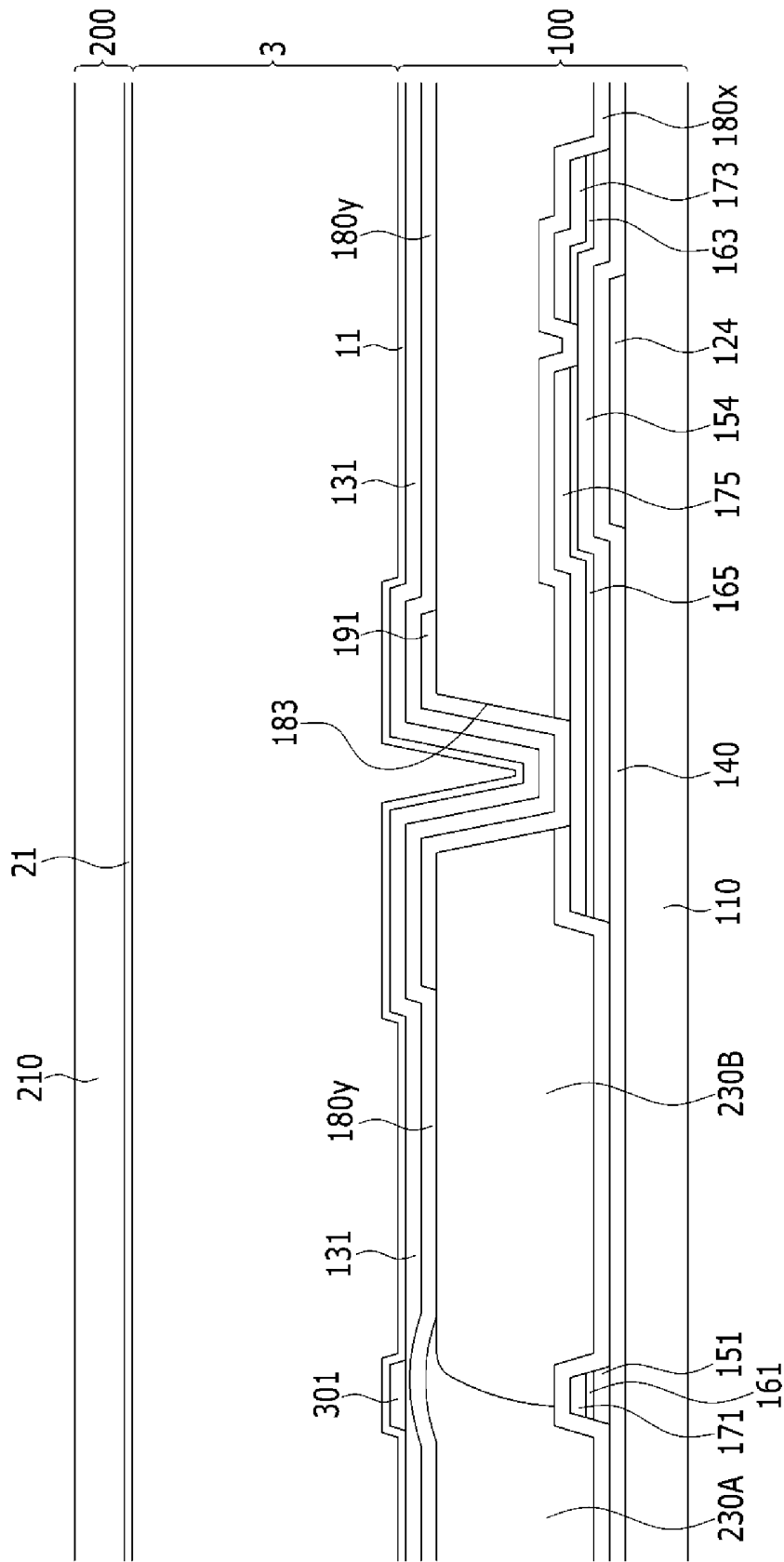

FIG. 27

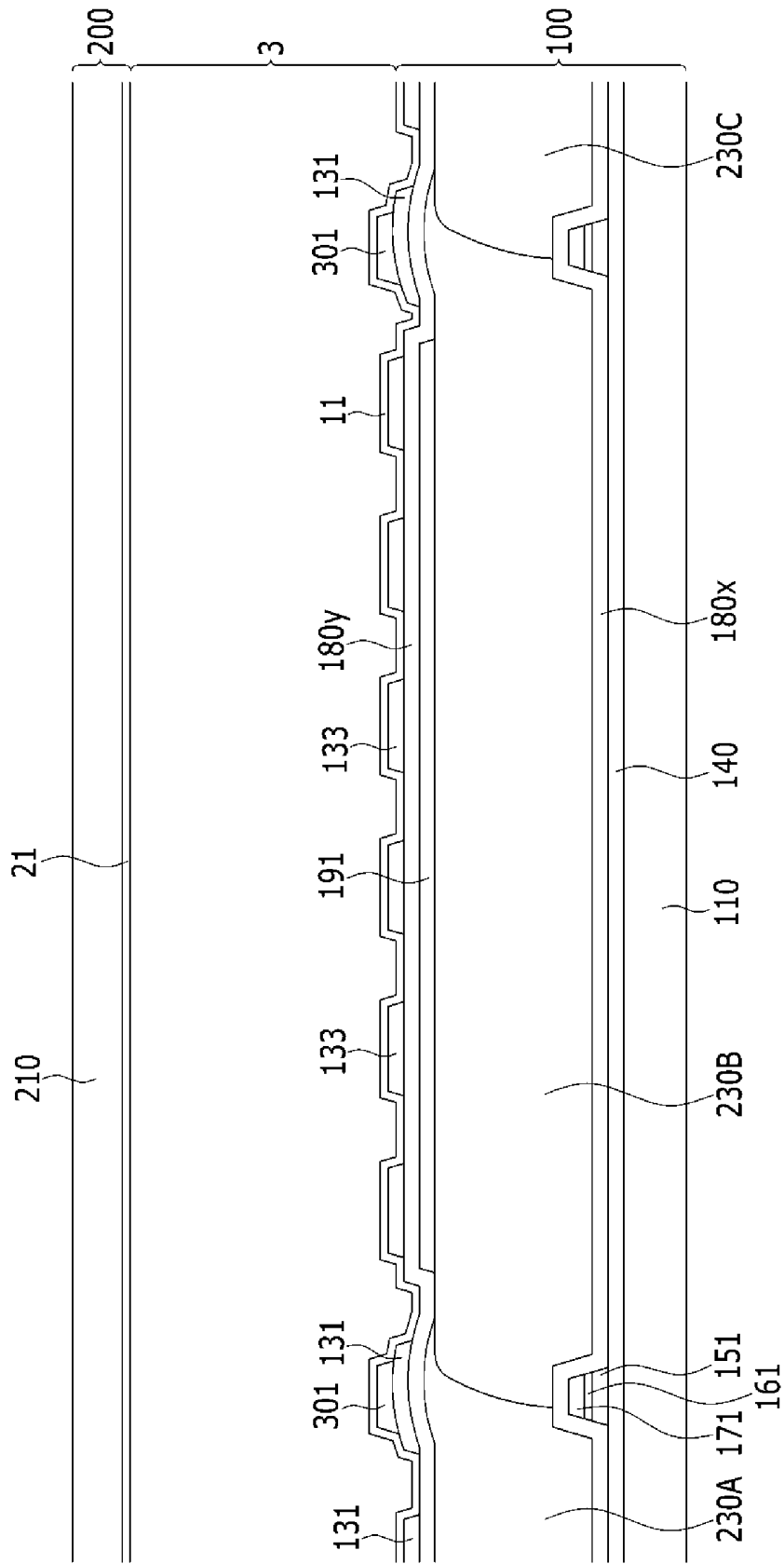

FIG. 28

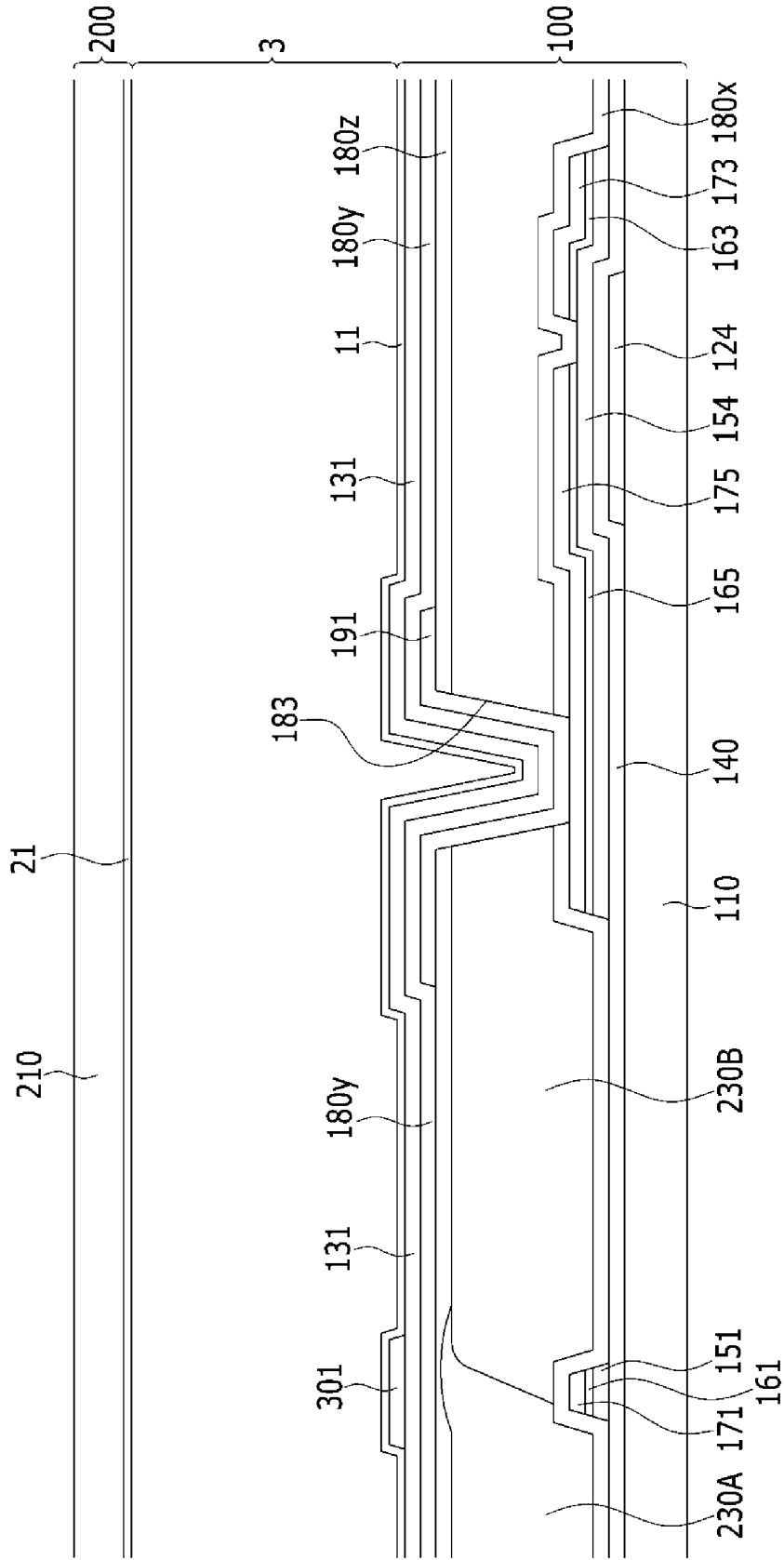

FIG. 29

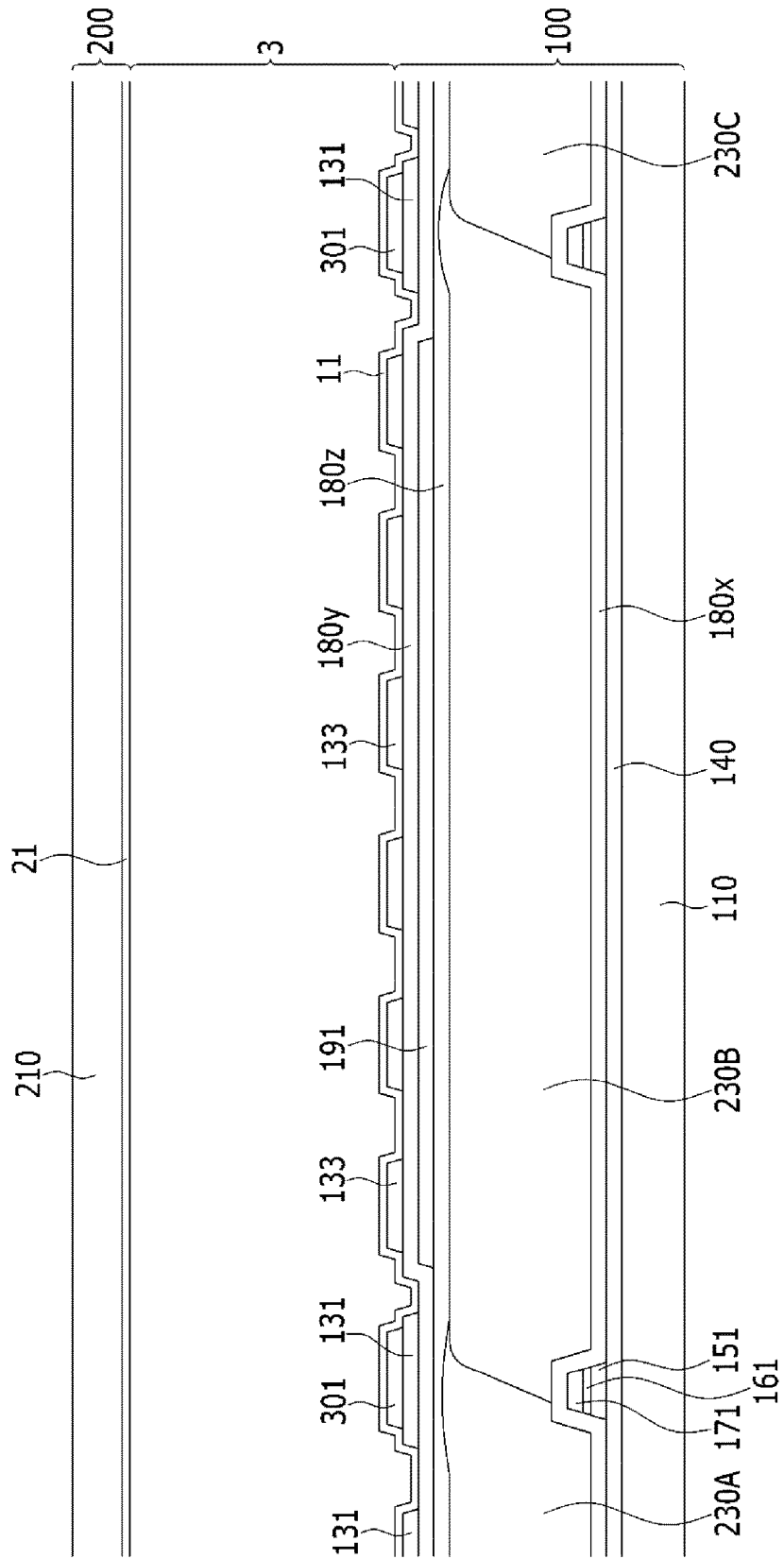

FIG. 30

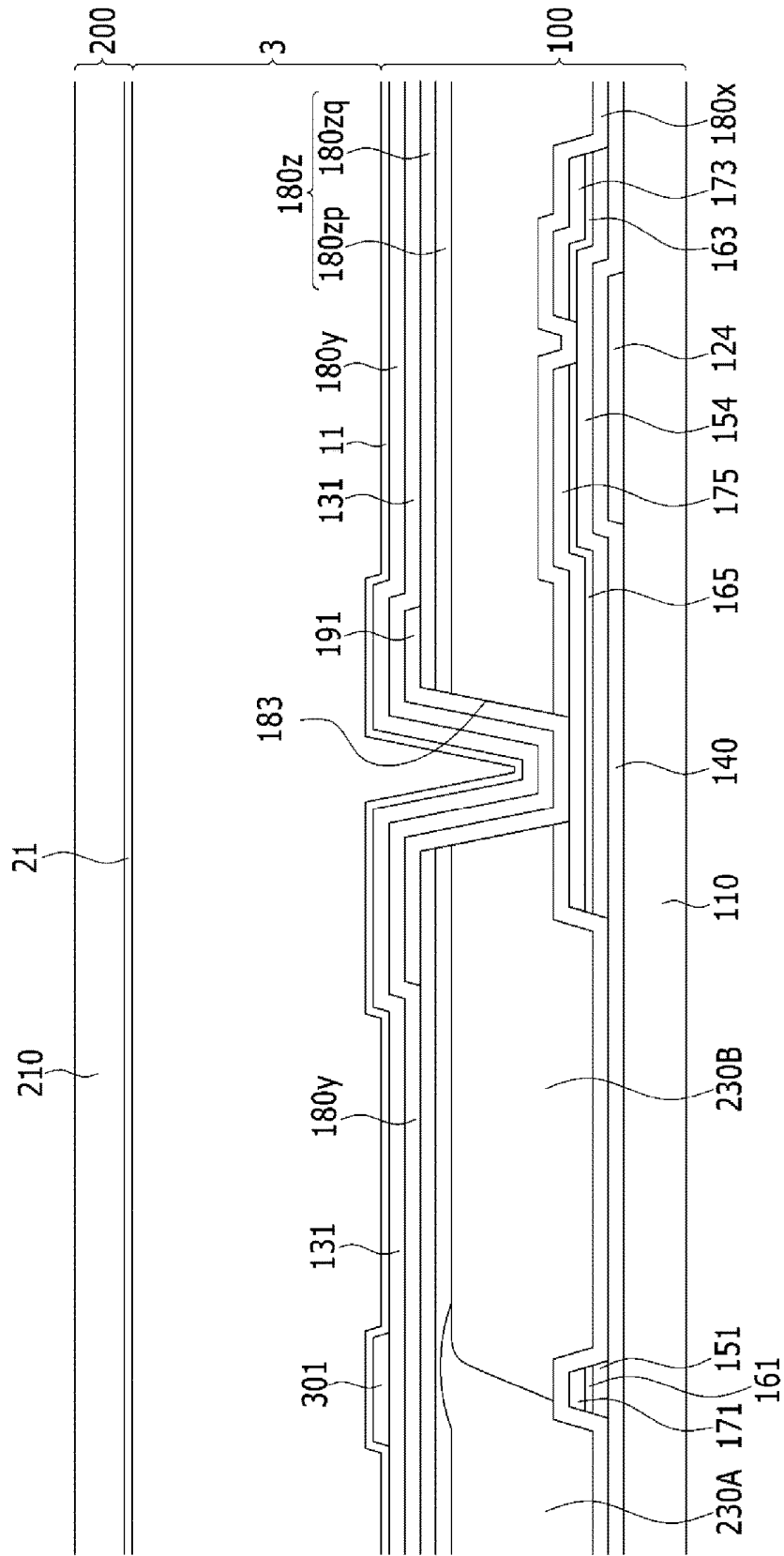

FIG. 31

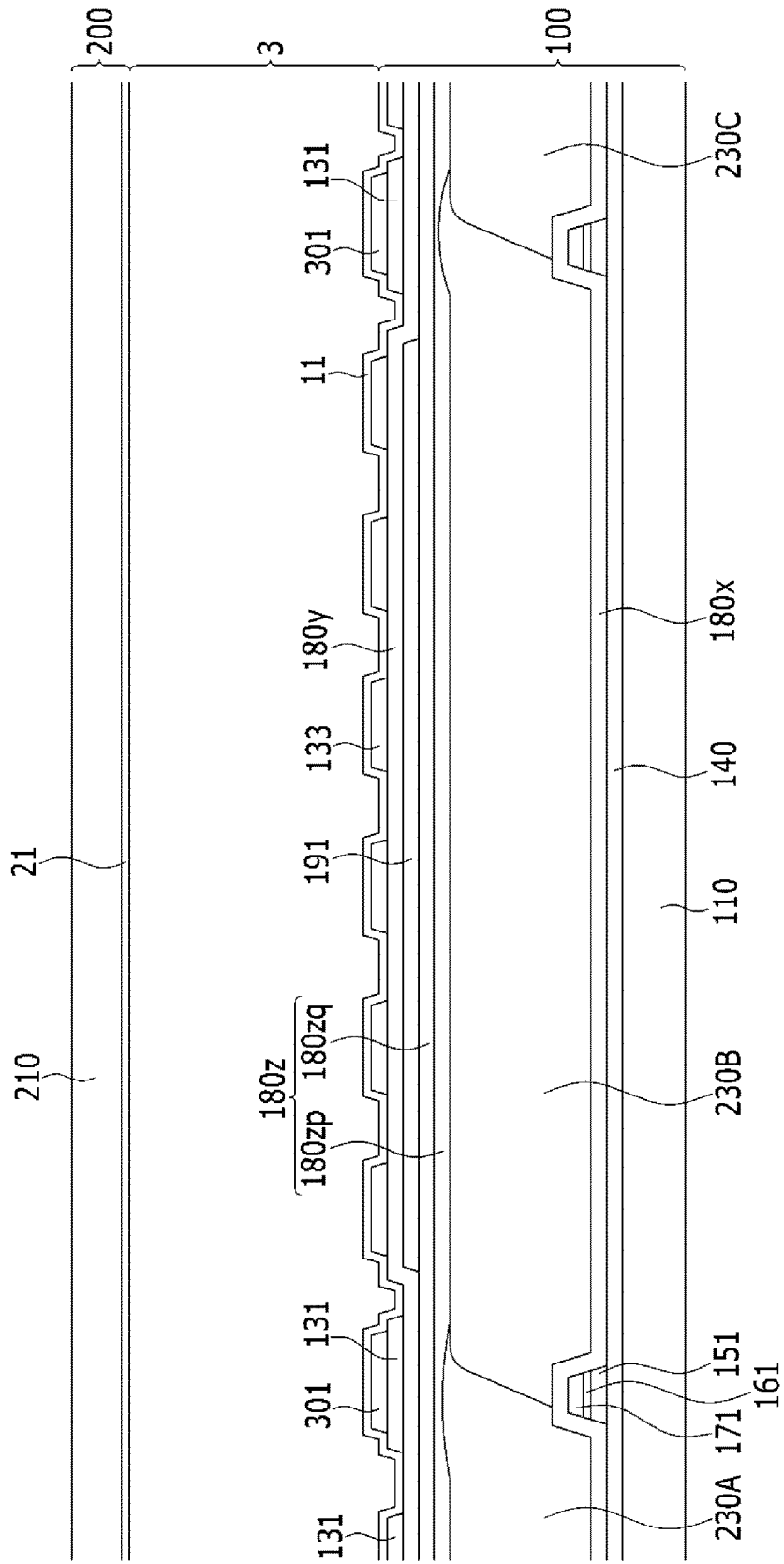

FIG. 32

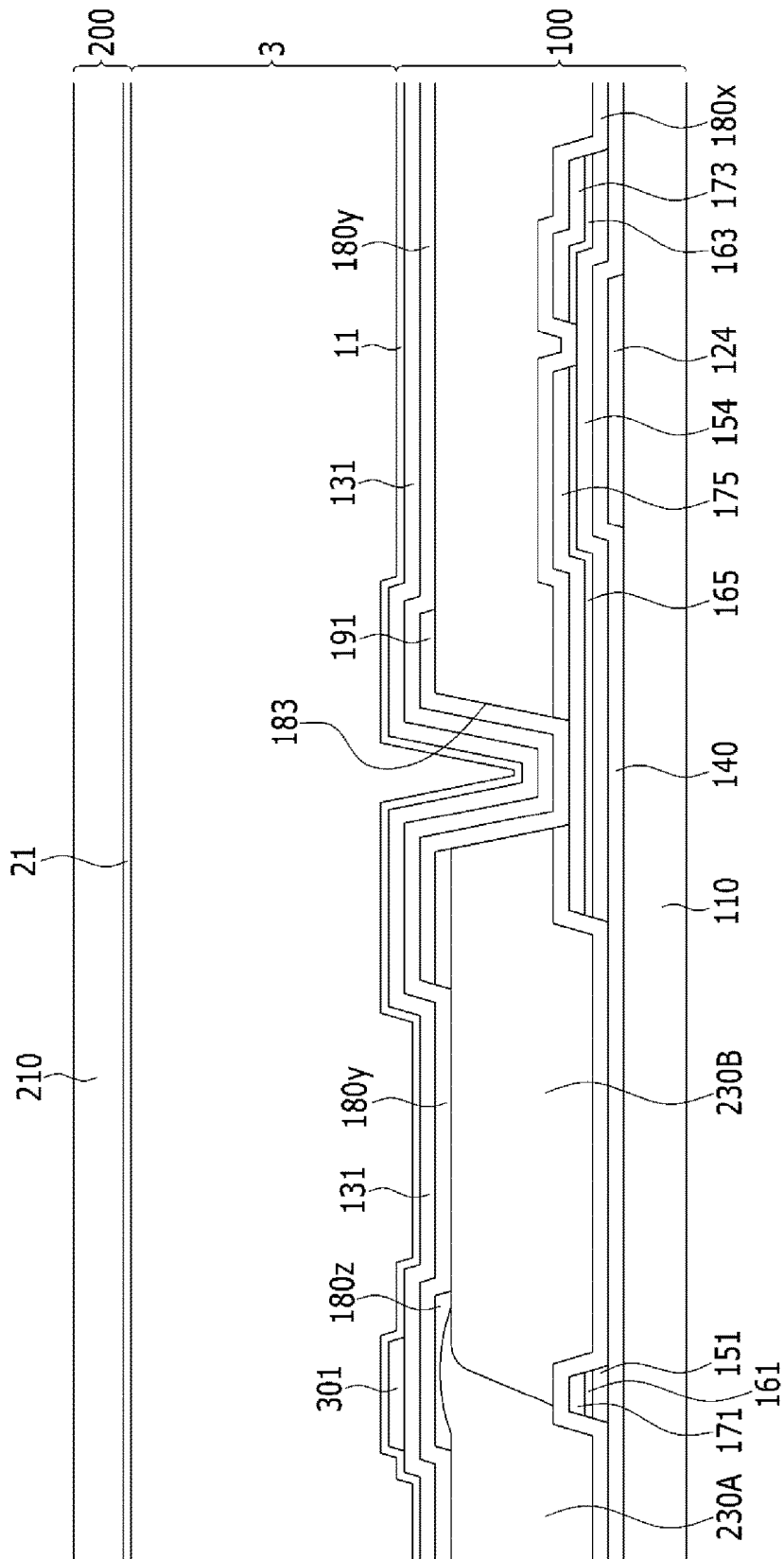

FIG. 33

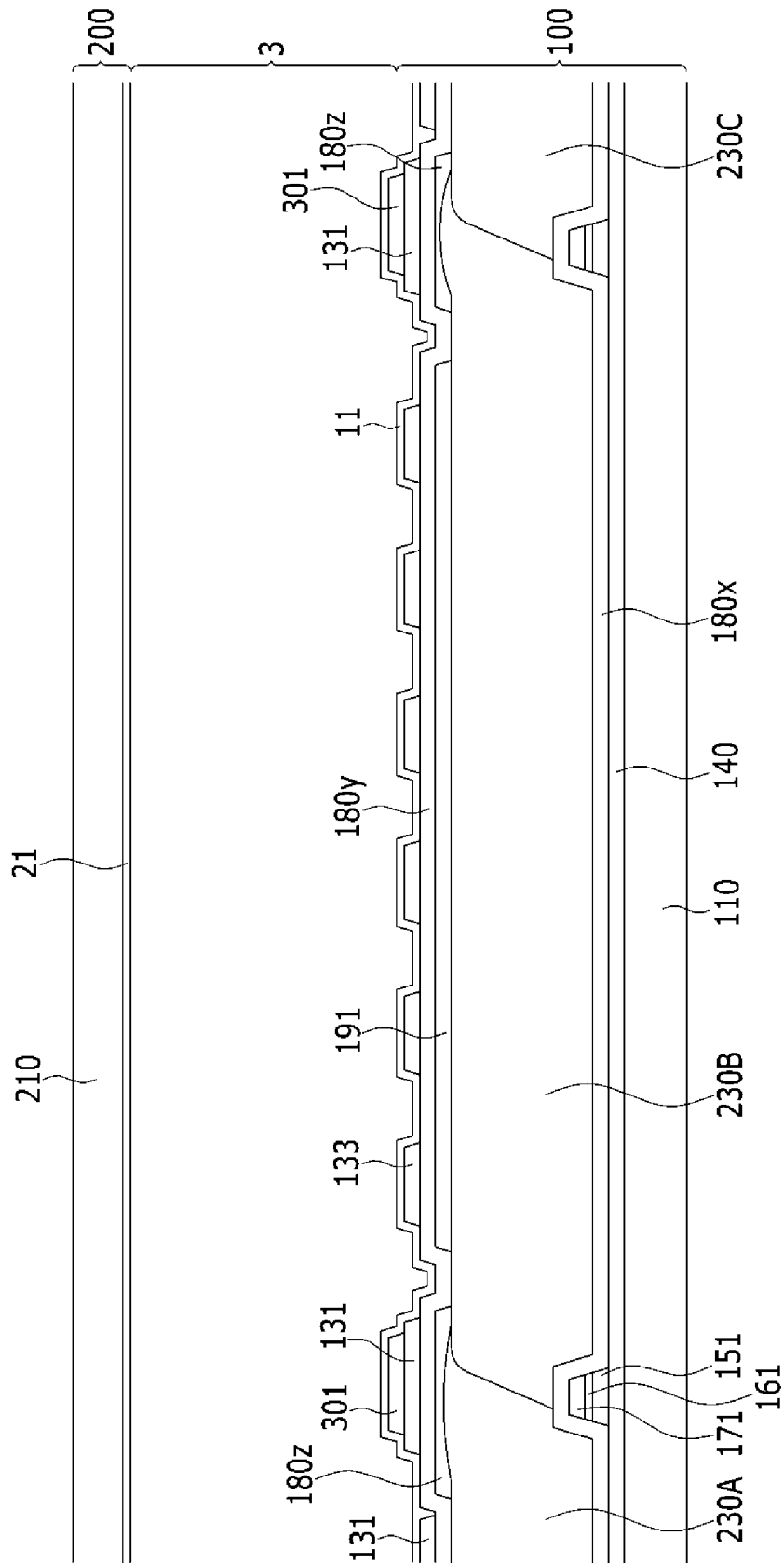



FIG. 35

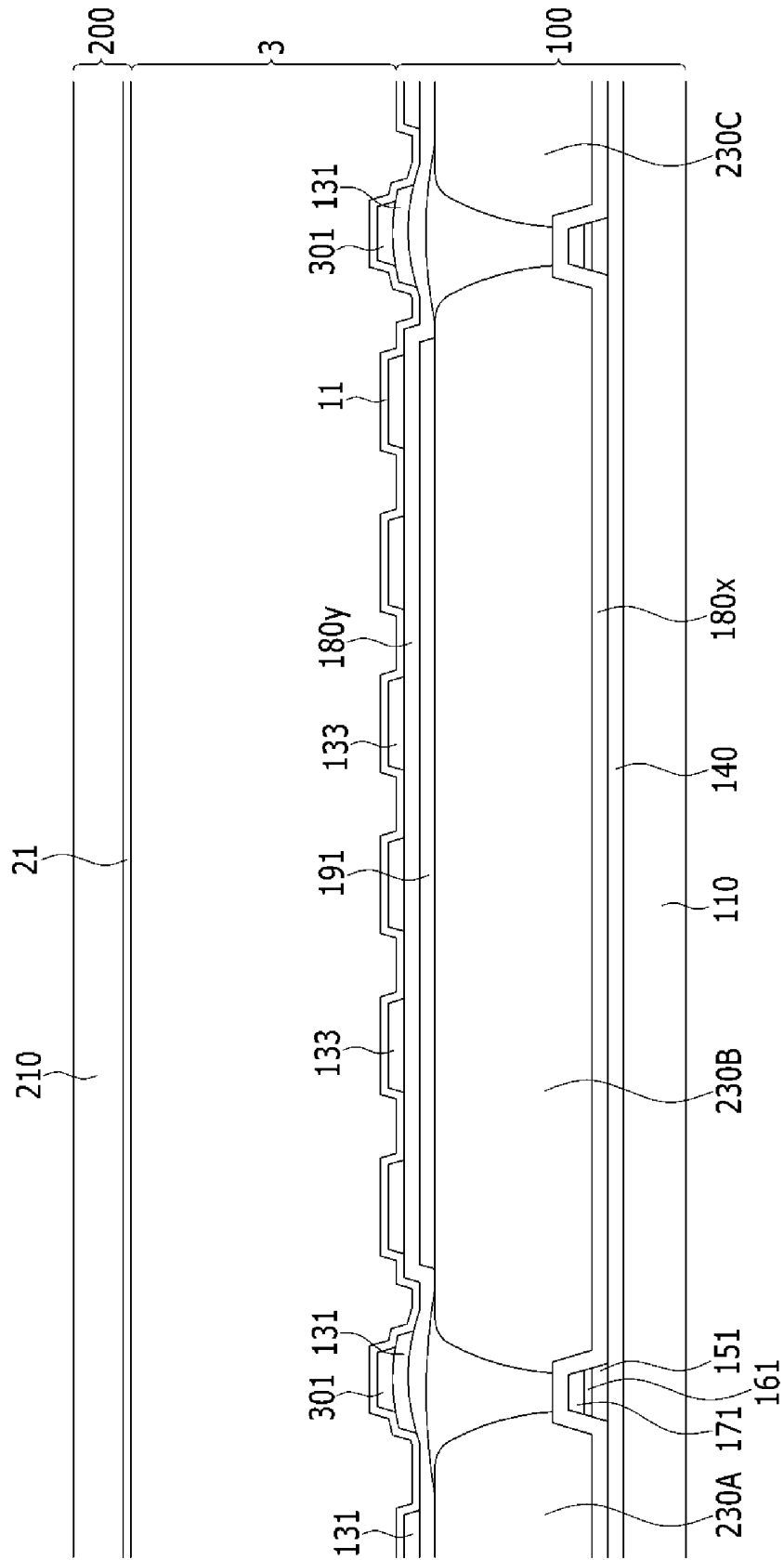

FIG. 36

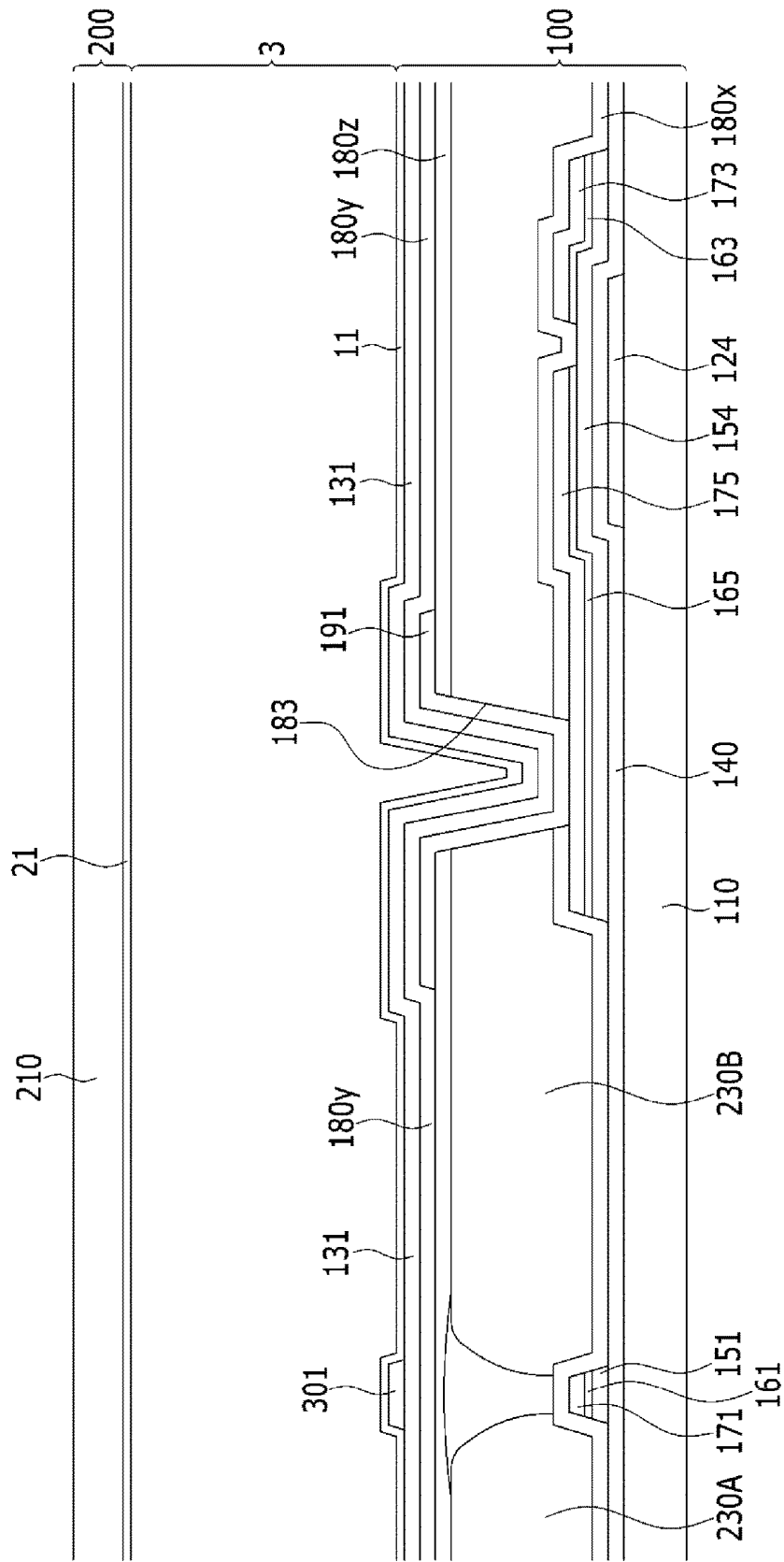

FIG. 37

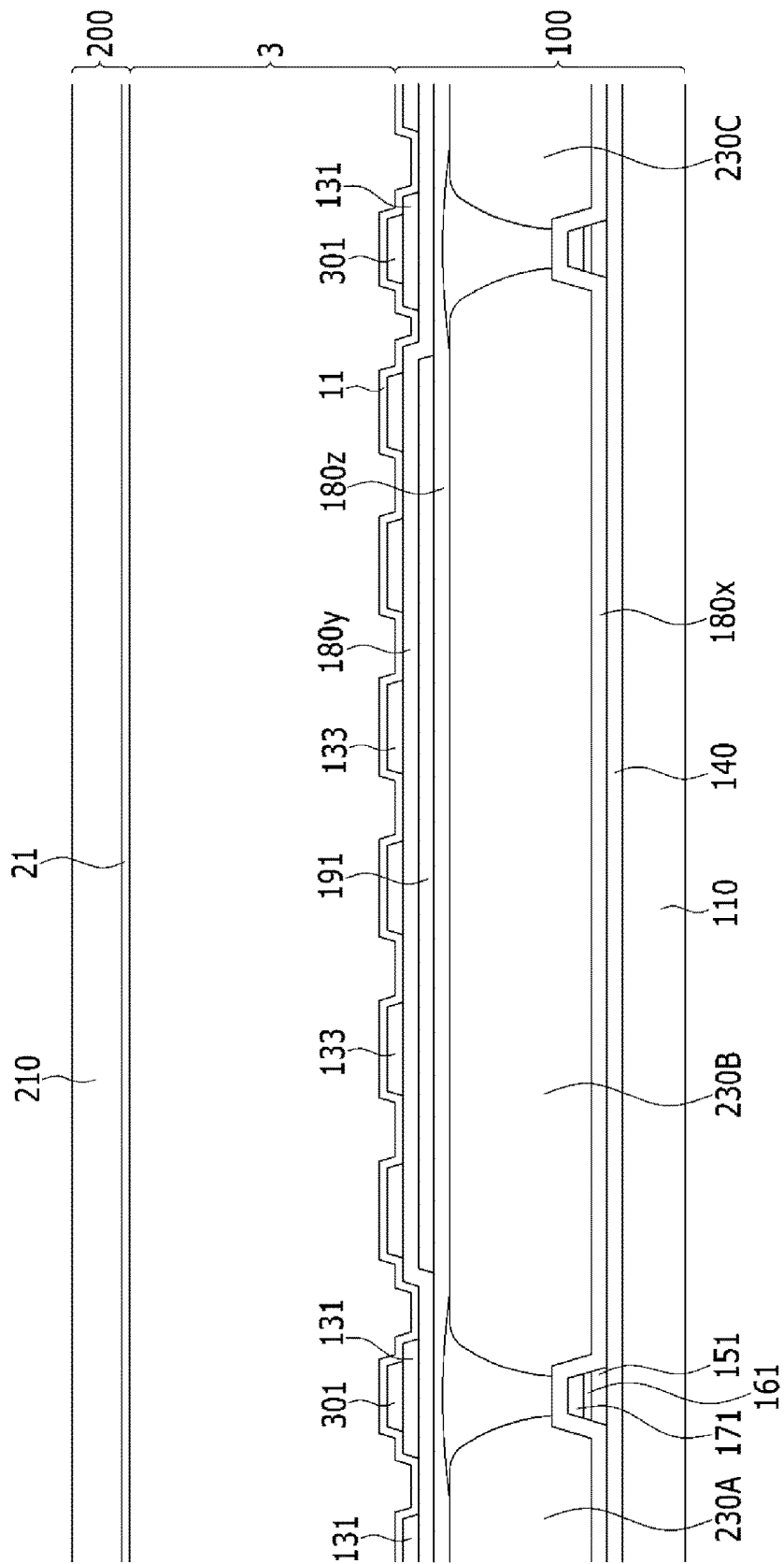

FIG. 38

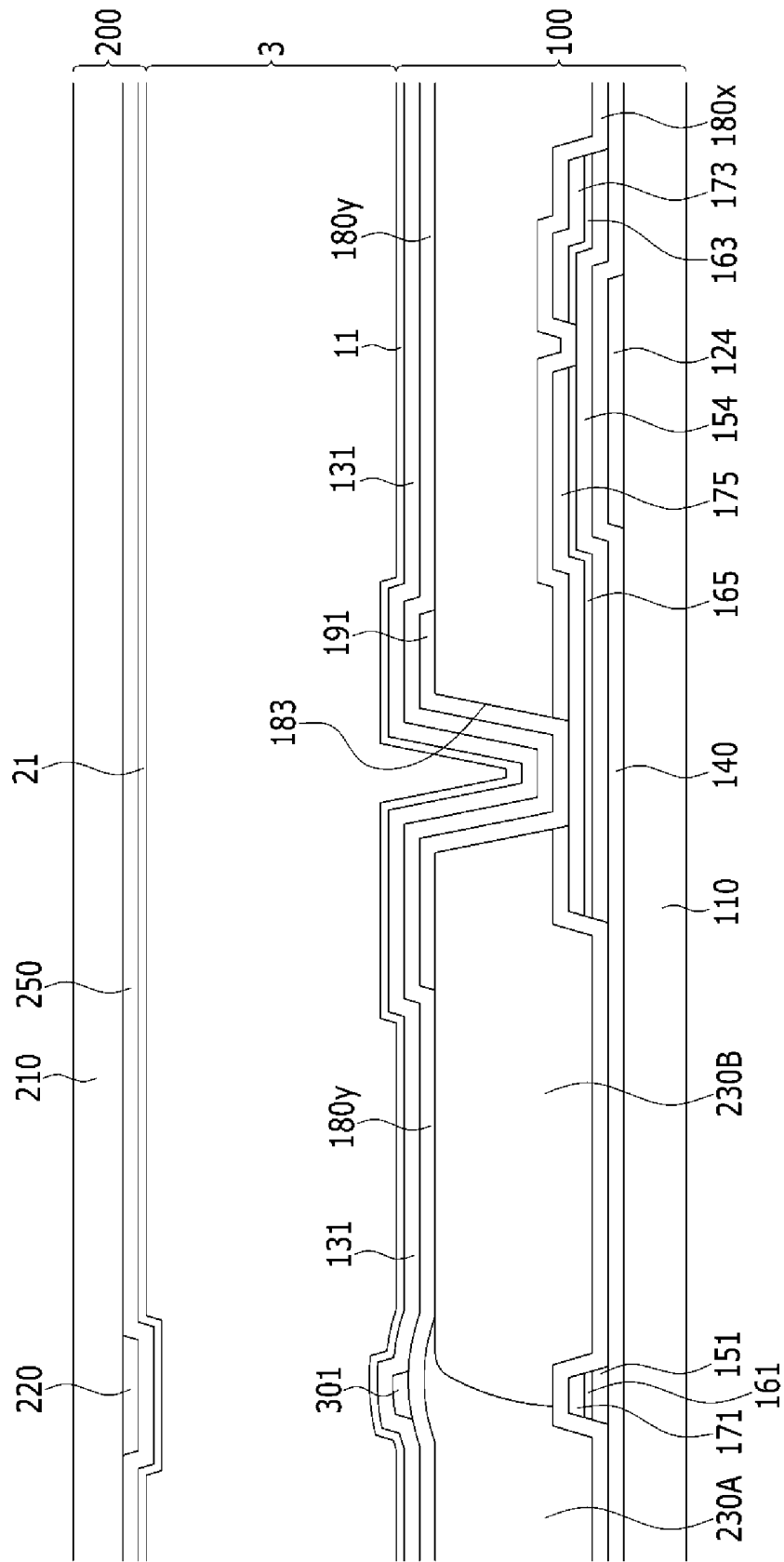

FIG. 39

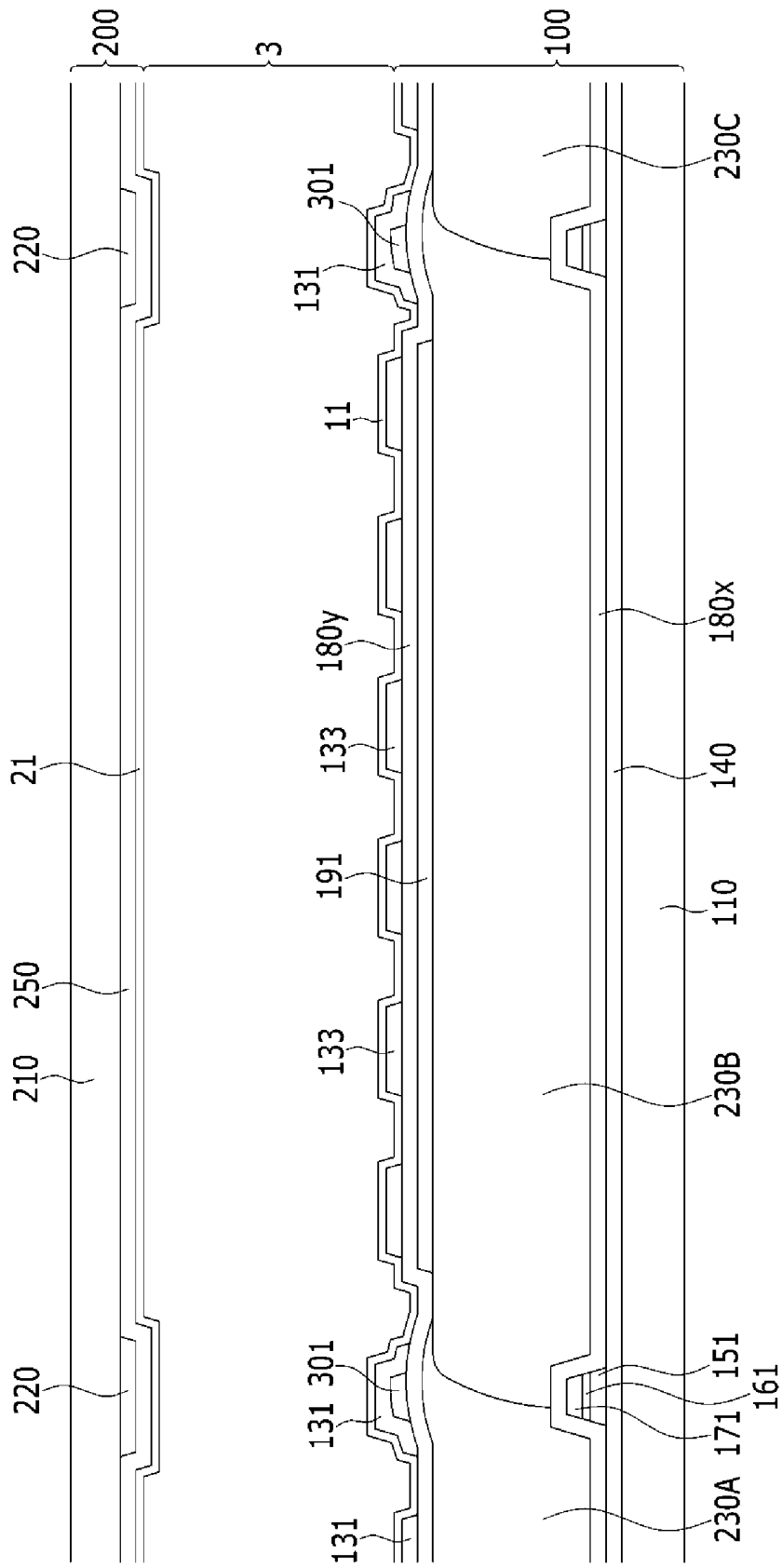

FIG. 40

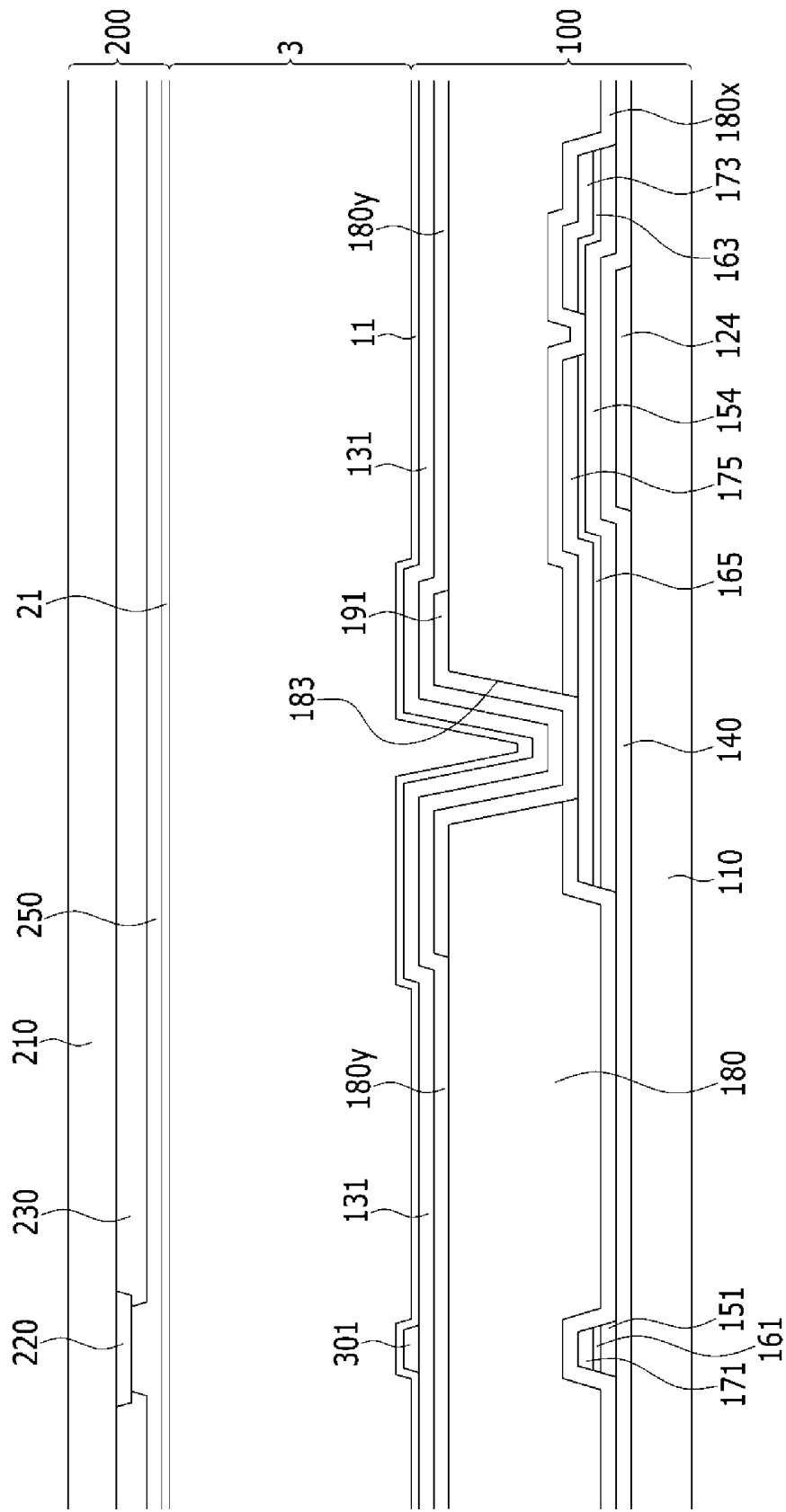

FIG. 41

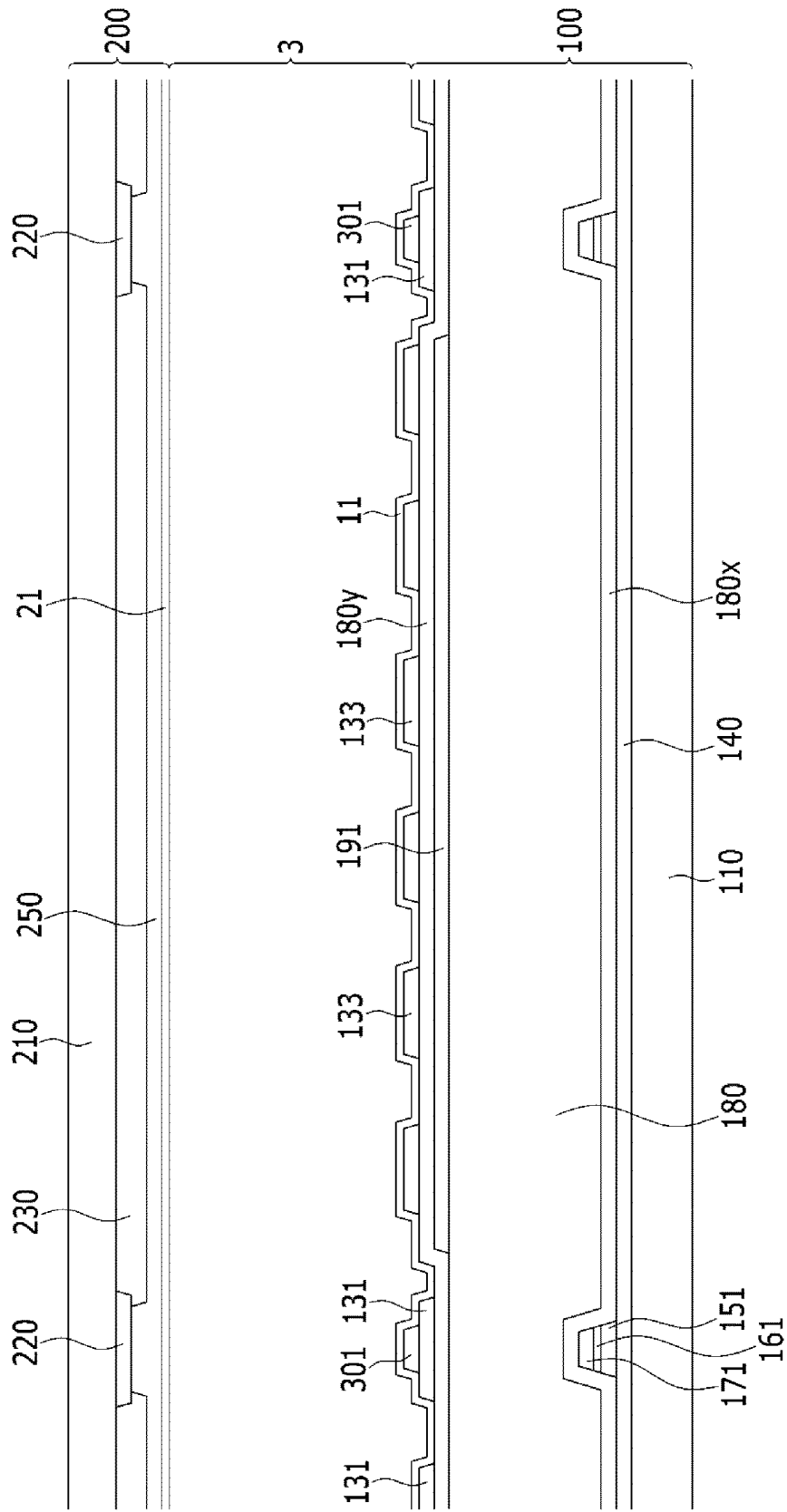

FIG. 42

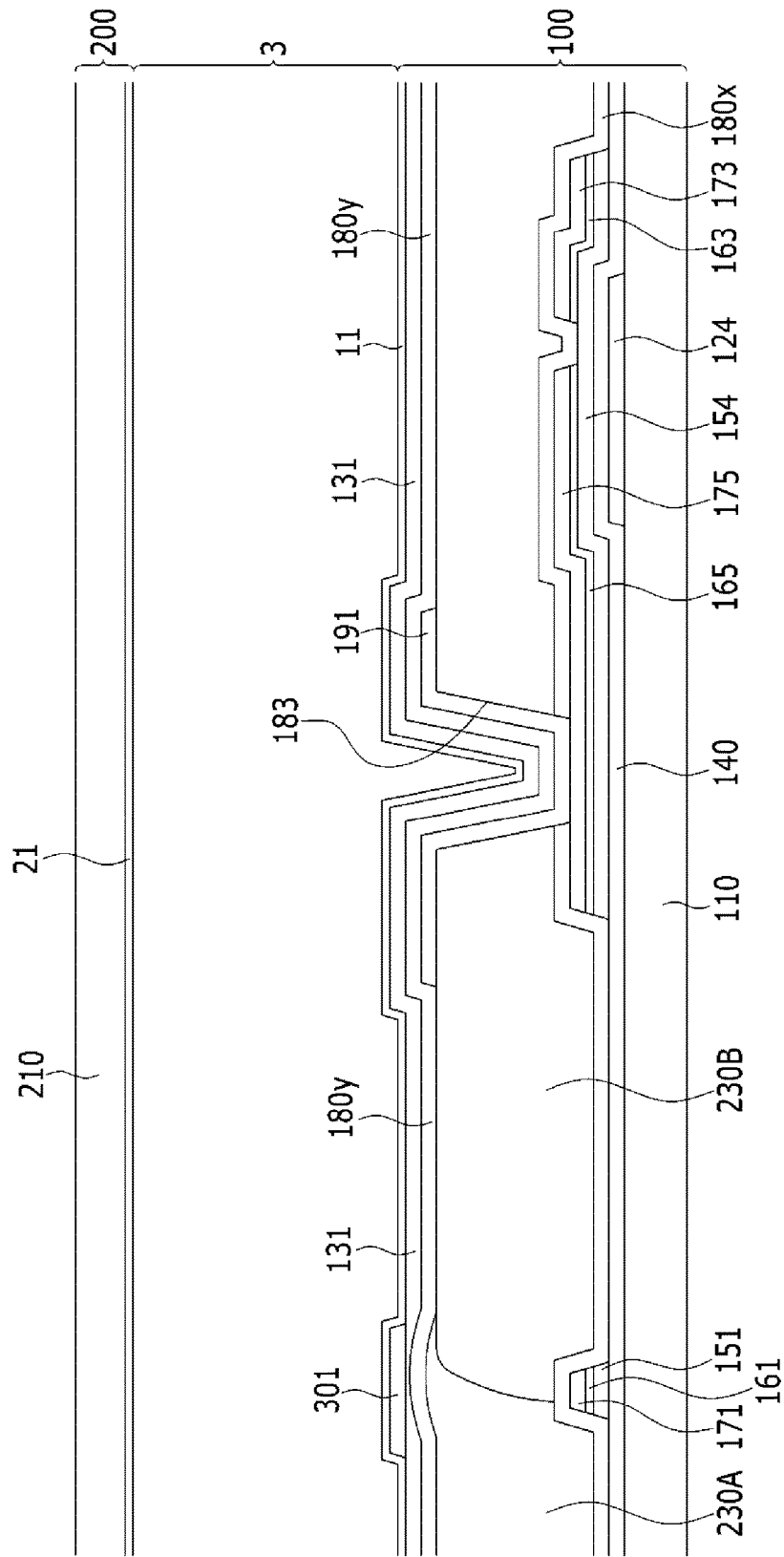

FIG. 43

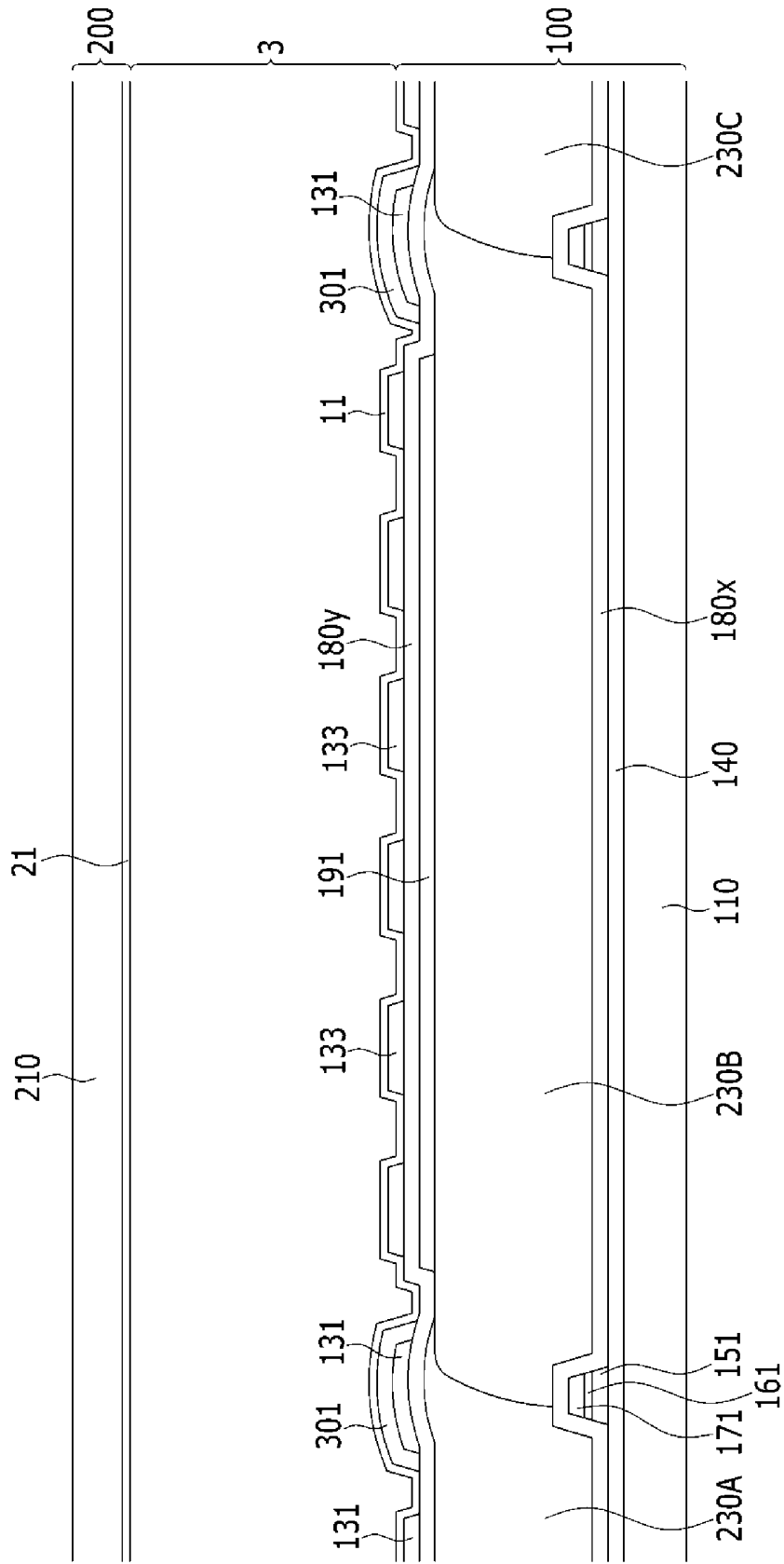

FIG. 44

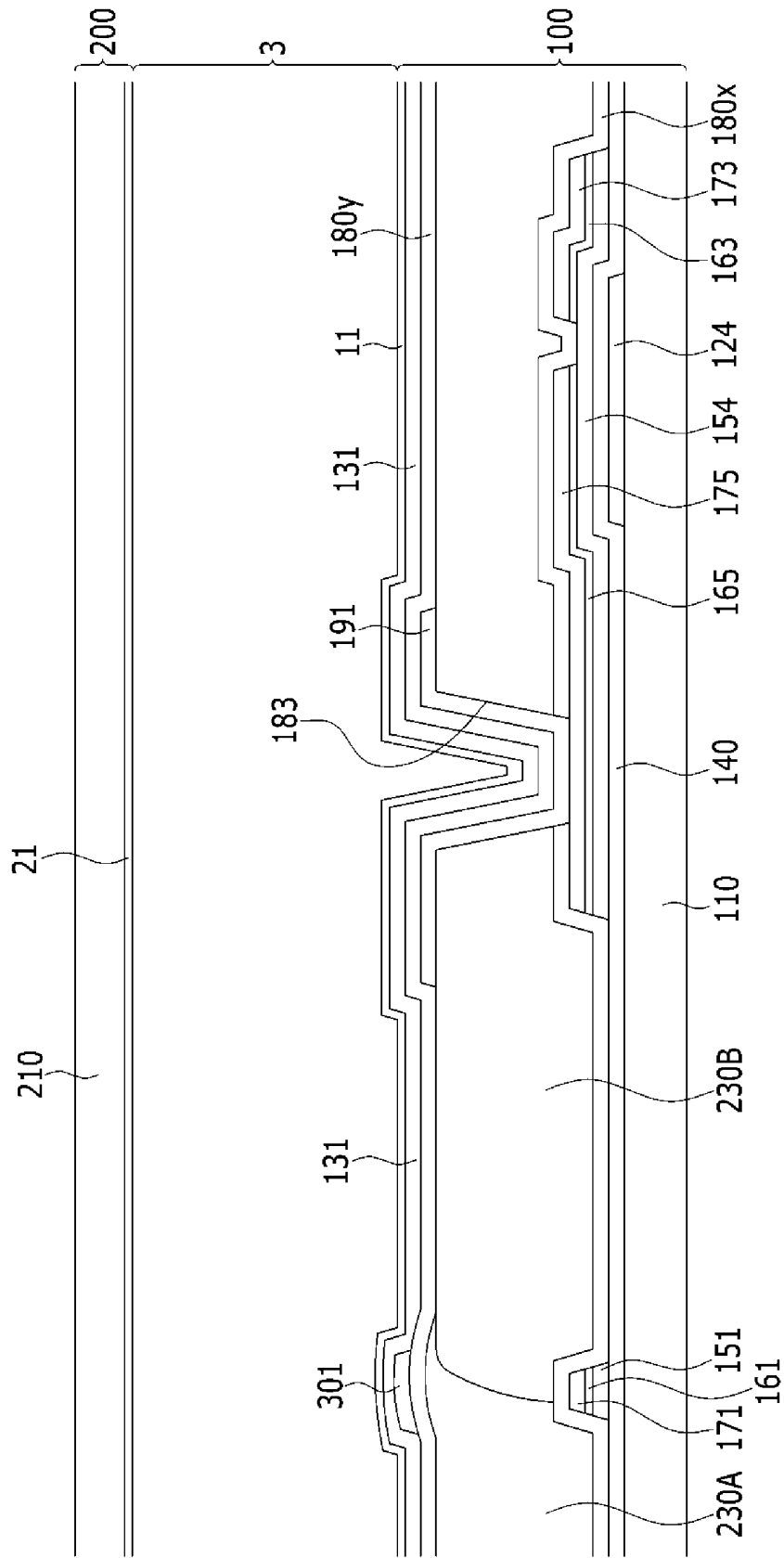

FIG. 45

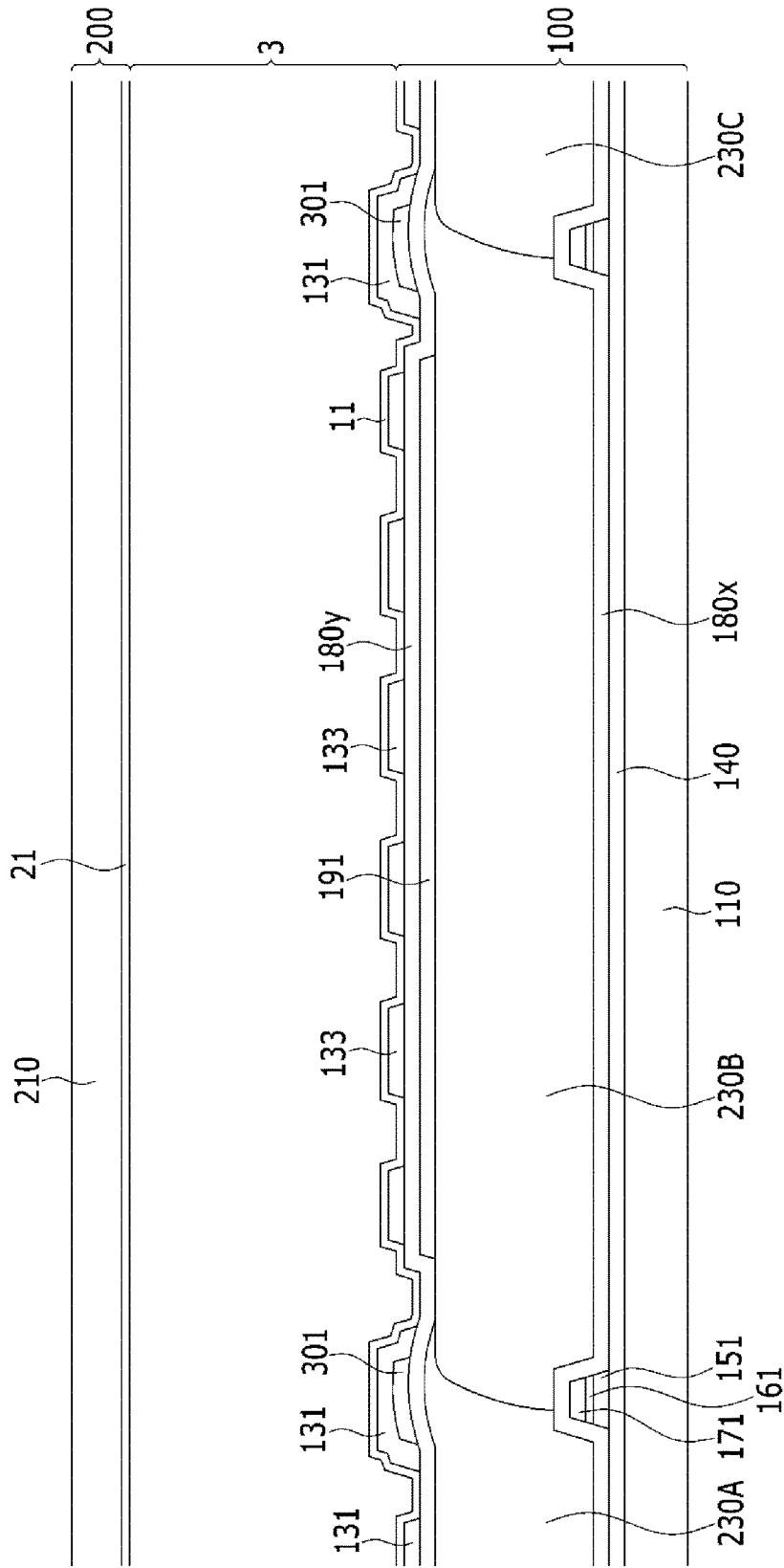

FIG. 46

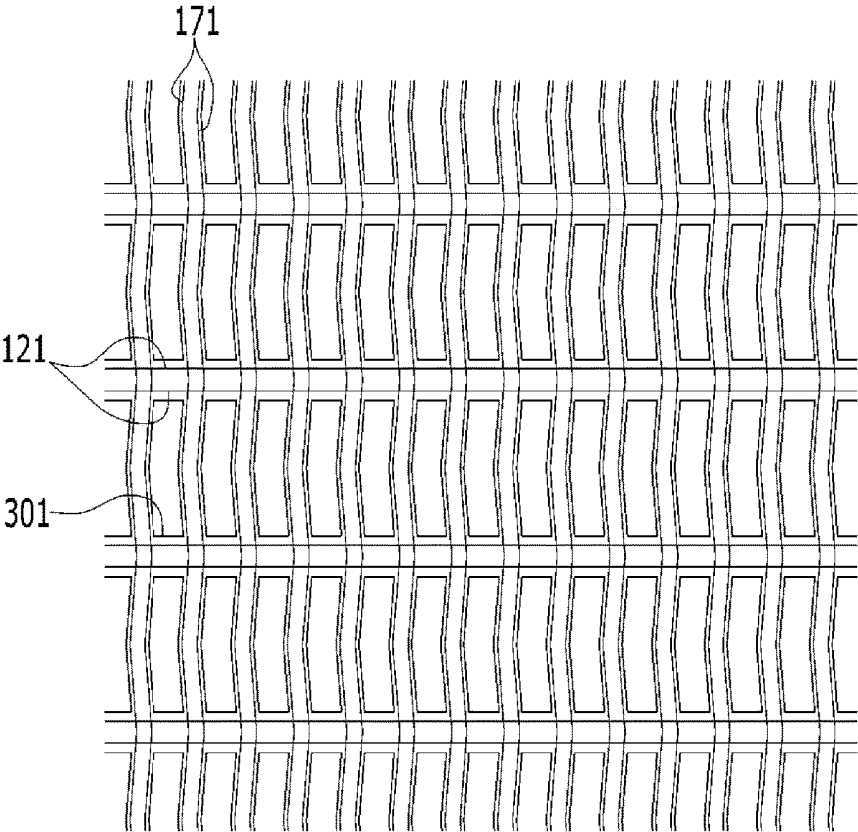

FIG. 47

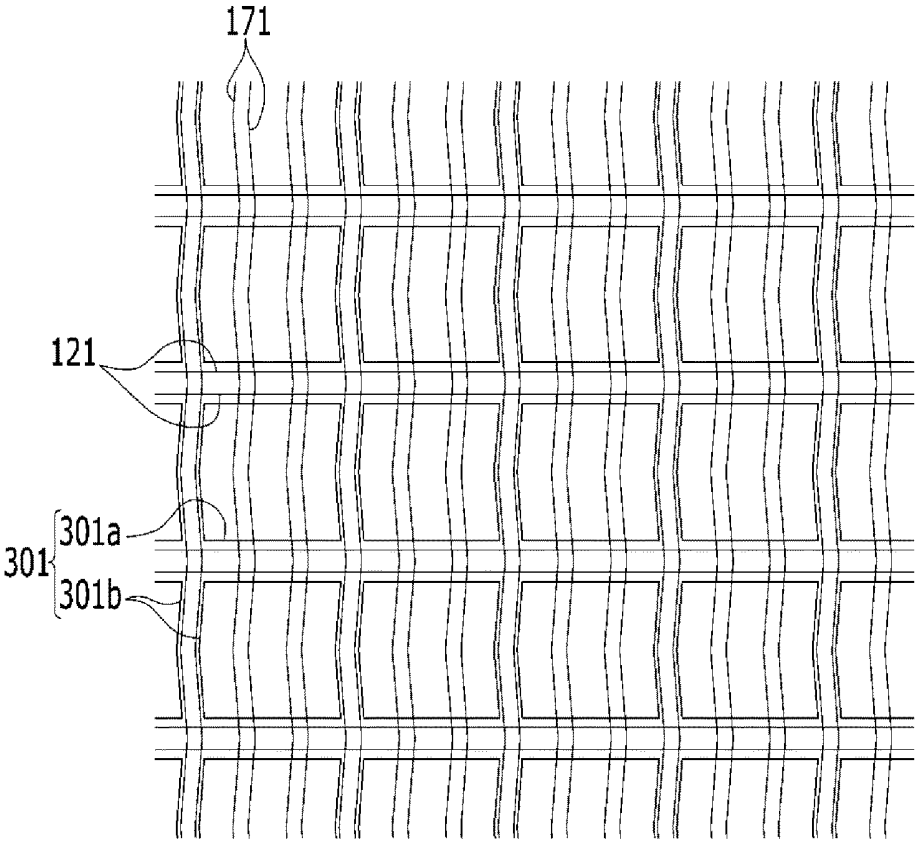

FIG. 48

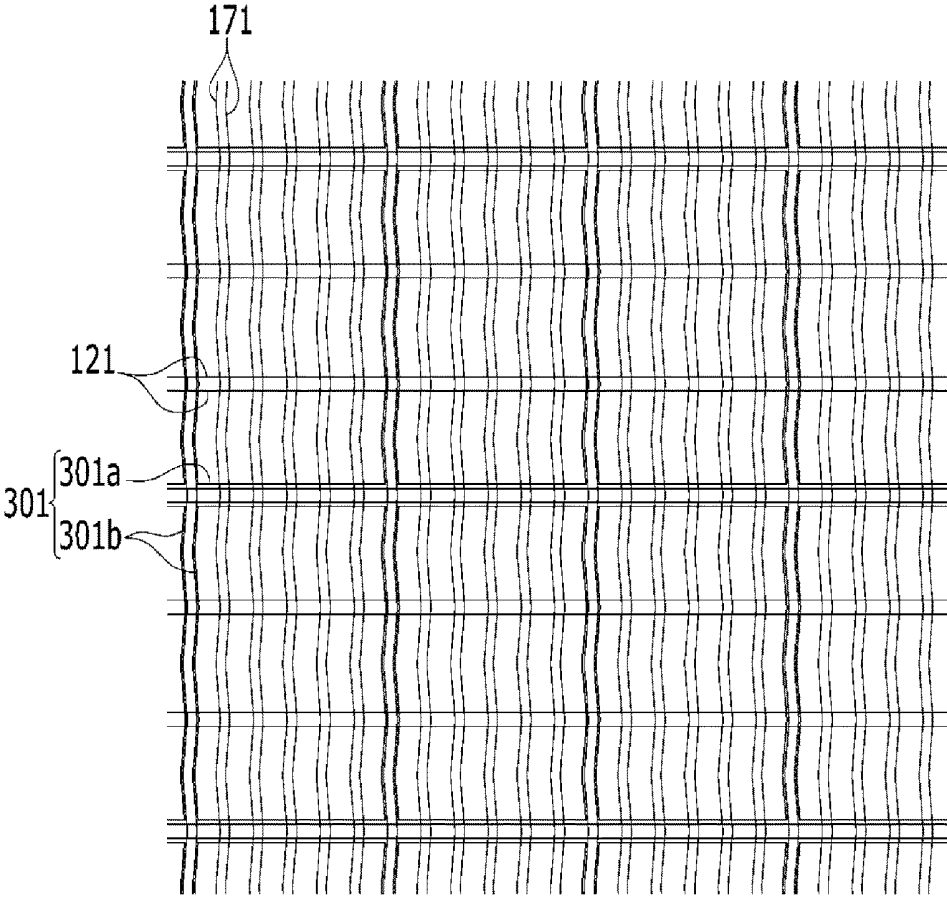

FIG. 49

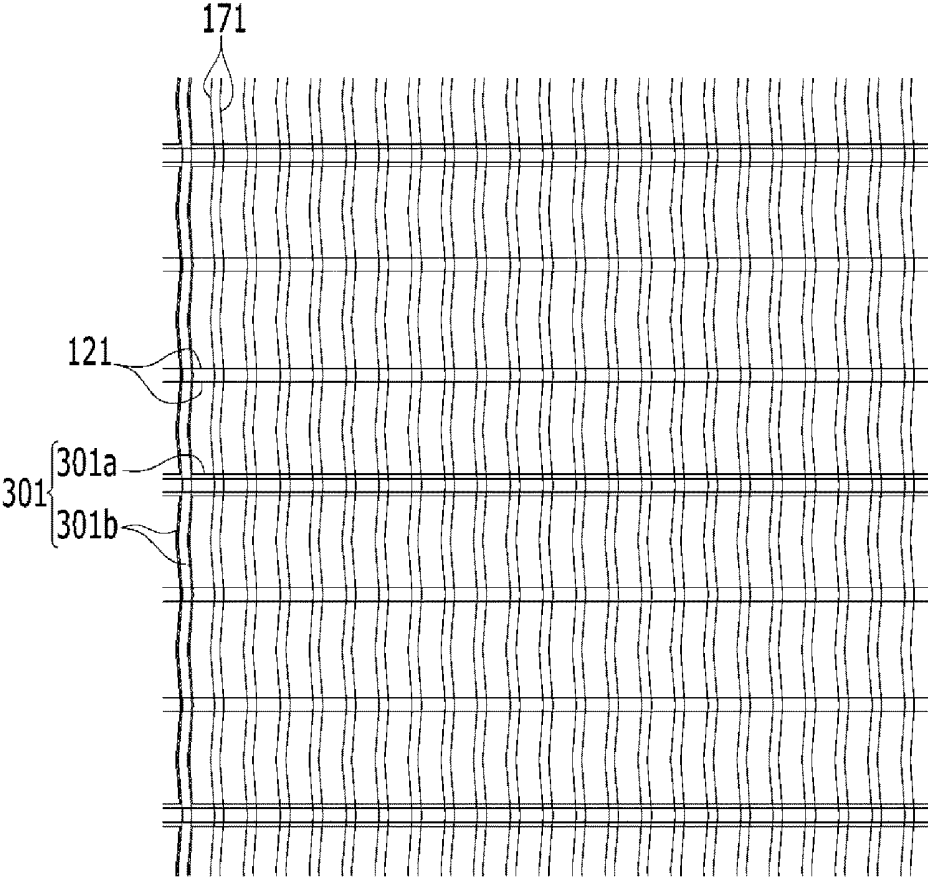
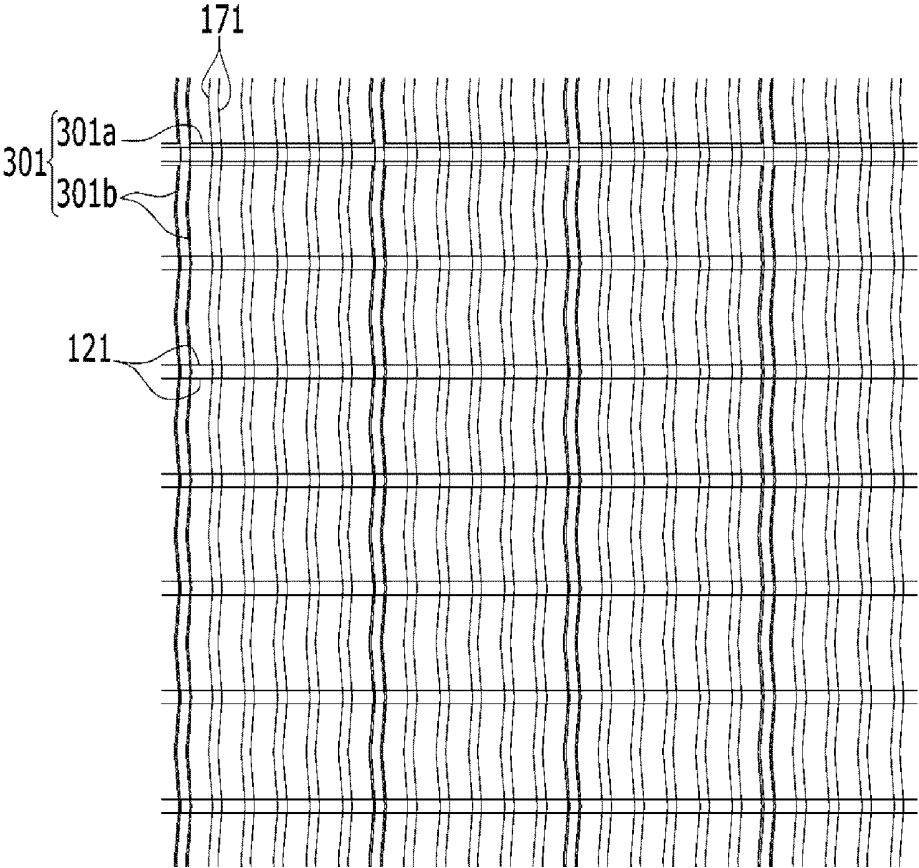

FIG. 50



**LIQUID CRYSTAL DISPLAY****CROSS-REFERENCE TO RELATED APPLICATION**

This application claims priority from and the benefit of Korean Patent Application No. 10-2011-0096523, filed on Sep. 23, 2011, which is hereby incorporated herein by reference for all purposes as if fully set forth herein.

**BACKGROUND****Field**

Exemplary embodiments of the present invention relate to a liquid crystal display.

**Discussion of the Background**

A liquid crystal display is one type of a flat panel display that is most widely used at present, and includes two display panels on which field generating electrodes, such as a pixel electrode and a common electrode, are formed, and a liquid crystal layer that is interposed therebetween. The liquid crystal display displays an image by applying a voltage to the field generating electrodes to generate an electric field on the liquid crystal layer, thereby determining the direction of liquid crystal molecules of the liquid crystal layer, and controlling the polarization of incident light. The transmittance of the liquid crystal display may increase when the liquid crystal molecules are precisely controlled.

Meanwhile, in the liquid crystal display, the pixel electrode and the common electrode generating the electric field in the liquid crystal layer may be provided on one display panel where the switching element is formed. In the case of the liquid crystal display of this form, a contact hole is formed to connect a common voltage line transmitting a common voltage and the common electrode. This arrangement, however, results in a decrease in the aperture ratio of the liquid crystal display.

The above information disclosed in this Background section is only for enhancement of understanding of the background of the invention and therefore it may contain information that does not form any part of the prior art nor what the prior art may suggest to a person of ordinary skill in the art.

**SUMMARY OF THE INVENTION**

Exemplary embodiments of the present invention may prevent a decreased aperture ratio of a liquid crystal display and may reduce signal delay of a common voltage line in a display having field generating electrodes disposed on the same substrate.

Additional features of the invention will be set forth in the description which follows, and in part will be apparent from the description, or may be learned by practice of the invention.

An exemplary embodiment of the present invention discloses a liquid crystal display which includes: a first substrate; a plurality of gate lines and a plurality of data lines disposed on the first substrate; a plurality of thin film transistors respectively connected to the plurality of gate lines and the plurality of data lines; a plurality of color filters disposed on the plurality of thin film transistors; a plurality of pixel electrodes and common electrodes disposed on the plurality of color filters and overlapping each other via a first insulating layer; and a common voltage line directly contacting the common electrode.

An exemplary embodiment of the present invention also discloses a liquid crystal display which includes: a first substrate; a plurality of gate lines and a plurality of data lines disposed on the first substrate; a plurality of thin film transistor respectively connected to the plurality of gate lines and the plurality of data lines; a plurality of color filters disposed on the plurality of thin film transistors; a common electrode disposed on the plurality of color filters; a common voltage line directly contacting the common electrode; a first insulating layer disposed on the common electrode; and a plurality of pixel electrodes disposed on the first insulating layer, wherein the common electrode and the plurality of pixel electrodes overlap each other, and at least one of the common electrode and the plurality of pixel electrodes includes a branch electrode.

An exemplary embodiment of the present invention also discloses a liquid crystal display which includes: a first substrate; a plurality of gate lines and a plurality of data lines disposed on the first substrate; a plurality of thin film transistors respectively connected to the plurality of gate lines and the plurality of data lines; a plurality of color filters disposed on the plurality of thin film transistors; a plurality of pixel electrodes disposed on the plurality of color filters; a first insulating layer disposed on the pixel electrodes; a common electrode disposed on the first insulating layer; and a common voltage line directly contacting the common electrode, wherein the common electrode and the plurality of pixel electrodes overlap each other, and at least one of the common electrode and the plurality of pixel electrodes includes a branch electrode.

It is to be understood that both the foregoing general description and the following detailed description are exemplary and explanatory and are intended to provide further explanation of the invention as claimed.

**BRIEF DESCRIPTION OF THE DRAWINGS**

The accompanying drawings, which are included to provide a further understanding of the invention and are incorporated in and constitute a part of this specification, illustrate embodiments of the invention, and together with the description serve to explain the principles of the invention.

FIG. 1 is a layout view of a liquid crystal display according to an exemplary embodiment of the present invention.

FIG. 2 and FIG. 3A are cross-sectional views of the liquid crystal display according to an exemplary embodiment of the present invention taken along the lines II-II and III-III of FIG. 1.

FIG. 3B is a cross-sectional view showing a portion of a manufacturing method of the liquid crystal display shown in FIG. 3A.

FIG. 4 and FIG. 5 are cross-sectional views of the liquid crystal display according to another exemplary embodiment of the present invention taken along the lines II-II and III-III of FIG. 1.

FIG. 6 and FIG. 7 are cross-sectional views of the liquid crystal display according to another exemplary embodiment of the present invention taken along the lines II-II and III-III of FIG. 1.

FIG. 8 and FIG. 9 are cross-sectional views of the liquid crystal display according to another exemplary embodiment of the present invention taken along the lines II-II and III-III of FIG. 1.

FIG. 10 and FIG. 11 are cross-sectional views of the liquid crystal display according to another exemplary embodiment of the present invention taken along the lines II-II and III-III of FIG. 1.

FIG. 12 and FIG. 13 are cross-sectional views of the liquid crystal display according to another exemplary embodiment of the present invention taken along the lines II-II and III-III of FIG. 1.

FIG. 14 and FIG. 15 are cross-sectional views of the liquid crystal display according to another exemplary embodiment of the present invention taken along the lines II-II and III-III of FIG. 1.

FIG. 16 and FIG. 17 are cross-sectional views of the liquid crystal display according to another exemplary embodiment of the present invention taken along the lines II-II and III-III of FIG. 1.

FIG. 18 and FIG. 19 are cross-sectional views of the liquid crystal display according to another exemplary embodiment of the present invention taken along the lines II-II and III-III of FIG. 1.

FIG. 20 is a layout view of a liquid crystal display according to another exemplary embodiment of the present invention, and FIG. 21 and FIG. 22 are cross-sectional views of the liquid crystal display taken along the lines XXI-XXI and XXII-XXII of FIG. 20.

FIG. 23 and FIG. 24 are cross-sectional views of the liquid crystal display according to another exemplary embodiment of the present invention taken along the lines XXI-XXI and XXII-XXII of FIG. 20.

FIG. 25 is a layout view of a liquid crystal display according to another exemplary embodiment of the present invention, and FIG. 26 and FIG. 27 are cross-sectional views of the liquid crystal display taken along the lines XXVI-XXVI and XXVII-XXVII of FIG. 25.

FIG. 28 and FIG. 29 are cross-sectional views of the liquid crystal display according to another exemplary embodiment of the present invention taken along the lines XXVI-XXVI and XXVII-XXVII of FIG. 25.

FIG. 30 and FIG. 31 are cross-sectional views of the liquid crystal display according to another exemplary embodiment of the present invention taken along the lines XXVI-XXVI and XXVII-XXVII of FIG. 25.

FIG. 32 and FIG. 33 are cross-sectional views of the liquid crystal display according to another exemplary embodiment of the present invention taken along the lines XXVI-XXVI and XXVII-XXVII of FIG. 25.

FIG. 34 and FIG. 35 are cross-sectional views of the liquid crystal display according to another exemplary embodiment of the present invention taken along the lines XXVI-XXVI and XXVII-XXVII of FIG. 25.

FIG. 36 and FIG. 37 are cross-sectional views of the liquid crystal display according to another exemplary embodiment of the present invention taken along the lines XXVI-XXVI and XXVII-XXVII of FIG. 25.

FIG. 38 and FIG. 39 are cross-sectional views of the liquid crystal display according to another exemplary embodiment of the present invention taken along the lines XXVI-XXVI and XXVII-XXVII of FIG. 25.

FIG. 40 and FIG. 41 are cross-sectional views of the liquid crystal display according to another exemplary embodiment of the present invention taken along the lines XXVI-XXVI and XXVII-XXVII of FIG. 25.

FIG. 42 and FIG. 43 are cross-sectional views of the liquid crystal display according to another exemplary embodiment of the present invention taken along the lines XXVI-XXVI and XXVII-XXVII of FIG. 25.

FIG. 44 and FIG. 45 are cross-sectional views of the liquid crystal display according to another exemplary embodiment of the present invention taken along the lines XXVI-XXVI and XXVII-XXVII of FIG. 25.

FIG. 46, FIG. 47, FIG. 48, FIG. 49, and FIG. 50 are layout views of a signal line of a liquid crystal display according to another exemplary embodiment of the present invention.

#### DETAILED DESCRIPTION OF THE EXEMPLARY EMBODIMENTS

The invention is described more fully hereinafter with reference to the accompanying drawings, in which embodiments of the invention are shown. This invention may, however, be embodied in many different forms and should not be construed as limited to the embodiments set forth herein. Rather, these embodiments are provided so that this disclosure is thorough, and will fully convey the scope of the invention to those skilled in the art. In the drawings, the size and relative sizes of layers and regions may be exaggerated for clarity. Like reference numerals in the drawings denote like elements.

It will be understood that when an element such as a layer, film, region, or substrate is referred to as being “on” or “connected to” another element, it can be directly on or directly connected to the other element, or intervening elements may also be present. In contrast, when an element is referred to as being “directly on” or “directly connected to” another element, there are no intervening elements present. It will be understood that for purposes of this disclosure, “at least one of X, Y, and Z” can be construed as X only, Y only, Z only, or any combination of two or more items X, Y, and Z (e.g., XYZ, XYY, YZ, ZZ).

A liquid crystal display according to an exemplary embodiment of the present invention will be described with reference to FIG. 1, FIG. 2, FIG. 3A, and FIG. 3B. FIG. 1 is a layout view of a liquid crystal display according to an exemplary embodiment of the present invention, FIG. 2 and FIG. 3A are cross-sectional views of the liquid crystal display according to an exemplary embodiment of the present invention taken along the lines II-II and III-III of FIG. 1, and FIG. 3B is a cross-sectional view showing a portion of a manufacturing method of the liquid crystal display shown in FIG. 3A.

A liquid crystal display according to an exemplary embodiment of the present invention includes a lower panel 100 and an upper panel 200, and a liquid crystal layer 3 interposed between the two display panels 100 and 200.

First, the lower panel 100 will be described.

A plurality of gate lines 121 are formed on an insulation substrate 110.

The gate line 121 transmits gate signals and extends in a transverse direction. Each gate line 121 includes a plurality of gate electrodes 124.

A gate insulating layer 140 is formed on the gate line 121. The gate insulating layer 140 may be made of an inorganic insulator such as silicon nitride (SiNx) or silicon oxide (SiOx).

A plurality of semiconductors 151 are formed on the gate insulating layer 140. The semiconductor 151 includes a protrusion 154 extending toward the gate electrode 124. However, in a case of the liquid crystal display according to another exemplary embodiment of the present invention, the semiconductor 151 may be only disposed on the gate electrode 124.

A plurality of ohmic contacts 161, 163, and 165 are formed on the semiconductor 151. The ohmic contacts 163

and **165** face each other with respect to the gate electrode **124** and form a pair, and are disposed on the semiconductor **154**. The ohmic contacts **161**, **163**, and **165** may be made of a material such as n+ hydrogenated amorphous silicon in which an n-type impurity such as phosphorus is doped at a high concentration, or of silicide. However, in the case of the liquid crystal display according to another exemplary embodiment of the present invention, the ohmic contacts **161**, **163**, and **165** may be omitted.

A data conductor including a plurality of data lines **171** and a plurality of drain electrodes **175** is formed on the ohmic contacts **161**, **163**, and **165**.

The data lines **171** transmit a data signal and mainly extend in the longitudinal direction, thereby intersecting the gate lines **121**. Each data line **171** includes a plurality of source electrodes **173** that are extended toward the gate electrode **124**. The data line **171** is periodically bent and forms an oblique angle with respect to the extending direction of the gate line **121**. The oblique angle between the data line **171** and the extending direction of the gate line **121** may be 45 degrees or more. However, in the case of a liquid crystal display according to another exemplary embodiment of the present invention, the data line **171** may be extended in a straight line.

The drain electrode **175** includes one end of a bar type and the other end having a wide area that faces the source electrode **173** with respect to the gate electrode **124**.

The gate electrode **124**, the source electrode **173**, and the drain electrode **175** form a thin film transistor (TFT) as a switching element along with the semiconductor protrusion **154**. The semiconductor stripe **151** may have almost the same plane shape as the data line **171**, the drain electrode **175**, and the underlying ohmic contacts **161** and **165** except for the semiconductor protrusion **154** of the thin film transistor.

A first passivation layer **180x** is positioned on the data conductor **171** and **175** and the exposed semiconductor protrusion **154**, and the first passivation layer **180x** may be made of an organic insulating material or an inorganic insulating material.

A plurality of color filters **230A**, **230B**, and **230C** are formed on the first passivation layer **180x**. Each of the color filters **230A**, **230B**, and **230C** may uniquely display one of primary colors, for example, three primary colors of red, green, and blue, or yellow, cyan, and magenta. Although not shown, the color filters may further include a color filter displaying a mixture of the primary colors or white, as well as the primary colors. The color filters **230A**, **230B**, and **230C** may be made of an organic material. Each of the color filters **230A**, **230B**, and **230C** may be extended in the direction of the data line **171**, and two neighboring color filters **230A** and **230B**, or **230B** and **230C**, may overlap on the boundary of the data line **171**.

A plurality of common electrodes **131** are formed on the color filters **230A**, **230B**, and **230C**. The common electrodes **131** may be made of a transparent conductive material such as ITO or IZO. The common electrode **131** having a plane shape may be formed with one plate on the whole surface of the substrate **110**, and may have an opening **138** disposed at a region corresponding to the circumference of the drain electrode **175**.

A common voltage line **301** is disposed on the common electrode **131**, thereby directly contacting the common electrode **131**. The common voltage line **301** includes a first portion parallel to the gate line **121** and a second portion parallel to the data line **171**, and the first portion and the second portion are connected to each other. However, in the

case of a liquid crystal display according to another exemplary embodiment of the present invention, at least one of the first portion and the second portion may be omitted.

The common voltage line **301** may be made of a metal that is opaque and has conductivity, which is different from the construction of the common electrode **131**. Also, the second portion of the common voltage line **301** disposed on the data line **171** may have a width that is equal to or greater than the data line **171**, thereby preventing light leakage between two pixels neighboring with respect to the data line **171**. Accordingly, a light blocking member between two pixels neighboring with respect to the data line **171** may be omitted.

The common voltage line **301** may be made of a conductive material. For example, the common voltage line **301** may be made of a conductive organic material having high electrical conductivity. In this case, reflection of light may be prevented, and the aperture ratio of the liquid crystal display may be increased.

The common electrode **131** and the common voltage line **301** may be simultaneously formed through one photolithography process using one mask. This will be described in detail with reference to FIG. 3B. As shown in (a) of FIG. 3B, the first conductive layer **130** forming the common electrode **131** and the second conductive layer **300** that is opaque and forms the common voltage line **301** are sequentially deposited on the substrate **110**. As shown in (b), a photosensitive film **400** is deposited and exposed by using a photomask **500** including a translucent area, a light transmitting area, and a light blocking area, and as shown in (c), a first photosensitive film pattern (**400a** and **400b**) has different thicknesses according to position. As shown in (d), a second conductive layer **300** and a first conductive layer **130** are simultaneously etched or sequentially etched by using the first photosensitive film pattern (**400a** and **400b**) as an etching mask to form a second conductive layer pattern **300a** and a first conductive layer pattern **130a**, and as shown in (e), the height of the first photosensitive film pattern (**400a** and **400b**) is decreased through ashing, and thereby the thickness of the thick photosensitive film pattern **400a** is decreased and simultaneously the thin photosensitive film pattern **400b** is removed to form a second photosensitive film pattern **400c**. As shown in (f), by using the second photosensitive film pattern **400c** as the etching mask, the second conductive layer pattern **300a** is etched via a method of etching the second conductive layer **300**, and as shown in (g), a common electrode portion **130a** and a common voltage line portion **300a** may be formed by one photolithography process. There are many methods of forming the difference in thicknesses according to the location of the photosensitive film. One example of the methods includes forming a photomask with a translucent area, a light transmitting area, and a light blocking area. The translucent area is provided with a slit pattern or a lattice pattern, or as a thin film having medium transmittance or thickness. In the case of utilizing the slit pattern, it is preferable that the slit width or the space between the slits is smaller than the resolution of exposure equipment used in the photolithography process. Another example of the methods includes using a reflowable photosensitive film. That is, the method forms a thin portion by making a photosensitive film flow into a region where the photosensitive film is not present after forming the reflowable photosensitive film with a general exposure mask having only a light transmitting area and a light blocking area. Since this reduces the number of photolithography processes, the manufacturing method is simplified. Although FIG. 3B shows gaps between portions of the common

electrode portion **130a**, as shown in FIG. **3A**, the common electrode **131** may have a plane shape formed with one plate on the whole surface of the substrate **110**.

A second passivation layer **180y** is disposed on the common electrode **131** and the common voltage line **301**. The second passivation layer **180y** may be made of an organic insulating material or an inorganic insulating material.

A pixel electrode **191** is formed on the second passivation layer **180y**. The pixel electrode **191** includes a plurality of branch electrodes **193** almost parallel to each other and separated from each other and lower and upper transverse portions **192** connecting upper and lower ends of the branch electrode **193**. The branch electrodes **193** of the pixel electrode **191** may be bent according to the data lines **171**. However, in the case of a liquid crystal display according to another exemplary embodiment of the present invention, the data line **171** and the branch electrode **193** of the pixel electrode **191** may be extended in one straight line. The pixel electrode **191** may be made of the transparent conductive material such as ITO or IZO.

The first passivation layer **180x**, the color filter **230B**, and the second passivation layer **180y** have a plurality of contact holes **183** exposing the drain electrode **175**, and the pixel electrode **191** is electrically connected to the drain electrode **175** through the contact hole **183**, thereby receiving a data voltage.

The contact hole **183** is formed at a position corresponding to the opening **138** of the common electrode **131**.

The pixel electrode **191** applied with the data voltage and the common electrode **131** applied with the common voltage generate an electric field to the liquid crystal layer **3**.

The branch electrode **193** of the pixel electrode **191** overlaps the common electrode **131** having the plane shape.

In the case of a liquid crystal display according to the present exemplary embodiment, the common electrode **131** covers a plurality of data lines **171** at one time and overlaps the data line **171**. Accordingly, crosstalk is reduced between the data line **171** and the pixel electrode **191** and light leakage caused by a parasitic capacitance between the data line **171** and the neighboring pixel electrode **191** may be reduced.

A first alignment layer **11** is coated on an inner surface of the lower panel **100**.

Next, the upper panel **200** will be described.

A second alignment layer **21** is coated on an insulation substrate **210**.

The first alignment layer **11** and the second alignment layer **21** may be horizontal alignment layers.

The liquid crystal layer **3** interposed between the lower panel **100** and the upper panel **200** includes liquid crystal molecules (not shown), wherein the liquid crystal molecules may be aligned so that a major axis thereof is formed to be horizontal with respect to the surfaces of the two display panels **100** and **200** in the state where an electric field is not present.

The liquid crystal layer **3** may have positive dielectric anisotropy or negative dielectric anisotropy. The liquid crystal molecules of the liquid crystal layer **3** may be aligned to have a pretilt in a predetermined direction, and the pretilt direction of the liquid crystal molecule may be changed according to the dielectric anisotropy of the liquid crystal layer **3**.

A backlight unit (not shown) generating and providing light to the two display panels **100** and **200** may be provided outside the substrate **110** of the lower panel **100**.

The pixel electrode **191** having the data voltage applied thereto generates an electric field in the liquid crystal layer **3** together with the common electrode **131** having a common voltage applied thereto, thereby determining the direction of the liquid crystal molecules of the liquid crystal layer **3** and displaying a corresponding image.

The lower panel **100** of the liquid crystal display according to an exemplary embodiment of the present invention includes the color filters **230A**, **230B**, and **230C** disposed between the data line **171** and the field generating electrodes **131** and **191**. In general, to reduce the parasitic capacitance between the data line **171** and the field generating electrodes **131** and **191**, a thick insulating layer having a low dielectric ratio is formed between the data line **171** and the field generating electrodes **131** and **191**. However, the liquid crystal display according to the present exemplary embodiment includes the color filters **230A**, **230B**, and **230C** functioning as the insulating layer between the data line **171** and the field generating electrodes **131** and **191**, and thereby an additional thick insulating layer is not formed. Accordingly, transmittance is greater than the case in which the thick insulating layer is formed in the lower panel **100** and the color filter is formed in the upper panel **200**.

When forming the color filter in the upper panel **100**, to prevent a color display error caused by misalignment between the pixel electrode of the lower panel **100** and the color filter of the upper panel **200**, a light blocking member having a large width should be formed between the color filters. However, when disposing the color filter in the lower panel **100**, the alignment error of the color filter is not considered such that the width of the light blocking member may be reduced. However, the width of the light blocking member is wider than the line width of the lower panel **100** such that the aperture ratio is decreased when forming the light blocking member in the upper panel **200**.

The liquid crystal display according to an exemplary embodiment of the present invention includes the common voltage line **301** directly disposed on the common electrode **131** and extending according to at least one of the gate line **121** and the data line **171**. In contrast to the common electrode **131**, the common voltage line **301** may be made of a metal that is opaque and has high conductivity, and in this case, the common voltage line **301** may have a function of preventing light leakage between two neighboring pixels. Accordingly, the light blocking member may be omitted.

As above described above, the liquid crystal display according to an exemplary embodiment of the present invention does not consider the alignment error between the lower panel **100** and the upper panel **200**, and the light blocking member may be omitted such that the aperture ratio is increased.

Also, because the common voltage line **301** directly disposed on the common electrode **131** and extending to at least one of the gate line **121** and the data line **171** is included, the signal delay of the common voltage applied to the common electrode **131** is simultaneously prevented, a contact hole connecting the common electrode **131** and the common voltage line **301** is not necessary, and the opaque common voltage line **301** overlaps the signal lines **121** and **171**, thereby increasing the aperture ratio of the liquid crystal display. As described above, the liquid crystal display according to an exemplary embodiment of the present invention includes the common voltage line **301** disposed directly on the common electrode **131** such that the signal delay of the common voltage is prevented, and simultaneously the aperture ratio of the liquid crystal display may be

increased. Also, the light blocking member may be omitted, and the manufacturing cost may be reduced.

Also, the common voltage line 301 may be formed of a conductive material. For example, the common voltage line 301 may be made of a conductive organic material having high electrical conductivity, and in this case, reflection of the light may be prevented.

Also, the liquid crystal display according to the present exemplary embodiment includes the common electrode 131 covering the data line 171 such that the crosstalk between the data line 171 and the pixel electrode 191 is reduced by the common electrode 131, and the light leakage by the parasitic capacitance between the data line 171 and the neighboring pixel electrode 191 may be reduced.

Next, the liquid crystal display according to another exemplary embodiment of the present invention will be described with reference to FIG. 4 and FIG. 5, as well as FIG. 1. FIG. 4 and FIG. 5 are cross-sectional views of the liquid crystal display according to another exemplary embodiment of the present invention taken along the lines II-II and III-III of FIG. 1.

The liquid crystal display according to the exemplary embodiment shown in FIG. 1, FIG. 4, and FIG. 5 is almost the same as the liquid crystal display according to the exemplary embodiment shown in FIG. 1, FIG. 2, and FIG. 3A. Accordingly, the description of similar portions is omitted.

In contrast to the liquid crystal display according to the exemplary embodiment shown in FIG. 1, FIG. 2, and FIG. 3A, the liquid crystal display according to the present exemplary embodiment further includes a third passivation layer 180z between the color filters 230A, 230B, and 230C and the common electrode 131. The third passivation layer 180z is disposed between the data line 171 and the common voltage line 301 such that the parasitic capacitance is decreased between the data line 171 and the common voltage line 301, thereby reducing the signal delay of the data line 171. The third passivation layer 180z may be made of an organic material and may have a flat surface. The third passivation layer 180z reduces a step formed by the overlapping of the color filters 230A, 230B, and 230C disposed in the neighboring pixels, and thereby the alignment layer 11 may be uniformly rubbed. However, the third passivation layer 180z may be an inorganic insulating layer and may prevent a component of the color filter from being exposed, and at this time, the third passivation layer 180z is formed at a lower temperature than the gate insulating layer 140 such that deformation and color change of the color filters 230A, 230B, and 230C may be prevented. Also, the third passivation layer 180z may reduce the transmittance loss resulting from the refractive index difference between the underlying color filter and the organic insulator.

All characteristics of the liquid crystal display according to the exemplary embodiment shown in FIG. 1, FIG. 2, and FIG. 3A may be applied to the liquid crystal display of the present exemplary embodiment. Also, the characteristics and the effects of the several constituent elements according to the above-described exemplary embodiment may be applied to the present exemplary embodiment having the same constituent elements.

Next, the liquid crystal display according to another exemplary embodiment of the present invention will be described with reference to FIG. 6 and FIG. 7 as well as FIG. 1. FIG. 6 and FIG. 7 are cross-sectional views of the liquid crystal display according to another exemplary embodiment of the present invention taken along the lines II-II and III-III of FIG. 1.

The liquid crystal display according to the exemplary embodiment shown in FIG. 1, FIG. 6, and FIG. 7 is similar to the liquid crystal display according to the exemplary embodiment shown in FIG. 1, FIG. 2, and FIG. 3A. Accordingly, the description of similar portions is omitted.

In contrast to the liquid crystal display according to the exemplary embodiment shown in FIG. 1, FIG. 2, and FIG. 3A, the liquid crystal display according to the present exemplary embodiment further includes the third passivation layer 180z between the color filters 230A, 230B, and 230C and the common electrode 131, and the third passivation layer 180z includes a lower layer 180zp and an upper layer 180zq. The lower layer 180zp of the third passivation layer 180z may be made of an inorganic insulating layer, and prevents the component of the color filter from being exposed to the outside. The upper layer 180zq of the third passivation layer 180z may be made of an organic material and may have a flat surface. The lower layer 180zp of the third passivation layer 180z is formed at a lower temperature than the gate insulating layer 140 such that deformation and color change of the color filters 230A, 230B, and 230C may be prevented, and may reduce the transmittance loss resulting from the refractive index difference between the underlying color filter and the organic insulator. The upper layer 180zq of the third passivation layer 180z may function as an organic insulator, and may reduce the step formed by the overlapping of the color filters 230A, 230B, and 230C disposed in the neighboring pixels, and thereby the alignment layer 11 may be uniformly rubbed. The third passivation layer 180z is disposed between the data line 171 and the common voltage line 301 such that the parasitic capacitance is decreased between the data line 171 and the common voltage line 301, thereby reducing the signal delay of the data line 171.

In the liquid crystal display according to the present exemplary embodiment, the lower layer 180zp of the third passivation layer 180z is the inorganic insulating layer and the upper layer 180zq is the organic insulator. However, in a liquid crystal display according to another exemplary embodiment of the present invention, the lower layer 180zp of the third passivation layer 180z may be the organic insulator and the upper layer 180zq may be the inorganic insulating layer.

All characteristics of the liquid crystal display according to the exemplary embodiment shown in FIG. 1, FIG. 2, and FIG. 3A may be applied to the liquid crystal display according to the present exemplary embodiment. Also, the characteristics and the effects of the several constituent elements according to the above-described exemplary embodiment may be applied to the present exemplary embodiment having the same constituent elements.

Next, the liquid crystal display according to another exemplary embodiment of the present invention will be described with reference to FIG. 8 and FIG. 9 as well as FIG. 1. FIG. 8 and FIG. 9 are cross-sectional views of the liquid crystal display according to another exemplary embodiment of the present invention taken along the lines II-II and III-III of FIG. 1.

The liquid crystal display according to the exemplary embodiment shown in FIG. 1, FIG. 8, and FIG. 9 is similar to the liquid crystal display according to the exemplary embodiment shown in FIG. 1, FIG. 2, and FIG. 3A. Accordingly, the description of similar portions is omitted.

In contrast to the liquid crystal display according to the exemplary embodiment shown in FIG. 1, FIG. 2, and FIG. 3A, the liquid crystal display according to the present exemplary embodiment further includes the third passiva-

tion layer 180z between the color filters 230A, 230B, and 230C and the common electrode 131, and the third passivation layer 180z is only disposed in a portion corresponding to a portion where the common voltage line 301 is disposed. The third passivation layer 180z may be made of the organic material or the inorganic material and may have a flat surface. In this way, the third passivation layer 180z is disposed in the portion corresponding to the portion where the common voltage line 301 is disposed such that the third passivation layer 180z is not formed in the display area (e.g., the area where the pixel electrode 191 is formed) displaying the image, and absorption of the light of the backlight by the third passivation layer 180z including the organic material may therefore be reduced and the reduction of transmittance may be prevented. The third passivation layer 180z is disposed between the data line 171 and the common voltage line 301 such that the parasitic capacitance is decreased between the data line 171 and the common voltage line 301, thereby reducing the signal delay of the data line 171.

All characteristics of the liquid crystal display according to the exemplary embodiment shown in FIG. 1, FIG. 2, and FIG. 3A may be applied to the liquid crystal display according to the present exemplary embodiment. Also, the characteristics and the effects of the several constituent elements according to the above-described exemplary embodiment may be applied to the present exemplary embodiment having the same constituent elements.

Next, the liquid crystal display according to another exemplary embodiment of the present invention will be described with reference to FIG. 10 and FIG. 11 as well as FIG. 1. FIG. 10 and FIG. 11 are cross-sectional views of the liquid crystal display according to another exemplary embodiment of the present invention taken along the lines II-II and III-III of FIG. 1.

The liquid crystal display according to the exemplary embodiment shown in FIG. 1, FIG. 10, and FIG. 11 is similar to the liquid crystal display according to the exemplary embodiment shown in FIG. 1, FIG. 2, and FIG. 3A. Accordingly, the description of similar portions is omitted.

In contrast to the liquid crystal display according to the exemplary embodiment shown in FIG. 1, FIG. 2, and FIG. 3A, in the liquid crystal display according to the present exemplary embodiment, the color filters 230A, 230B, and 203C of two neighboring pixels with respect to the data line 171 do not overlap, and a light blocking member 220 is disposed between two neighboring color filters 230A, 230B, and 203C. Also, the width of the second portion of the common voltage line 301 disposed at the position corresponding to the data line 171 may be almost equal to that of the data line 171.

All characteristics of the liquid crystal display according to the exemplary embodiment shown in FIG. 1, FIG. 2, and FIG. 3A may be applied to the liquid crystal display according to the present exemplary embodiment. Also, the characteristics and the effects of the several constituent elements according to the above-described exemplary embodiment may be applied to the present exemplary embodiment having the same constituent elements.

Next, the liquid crystal display according to another exemplary embodiment of the present invention will be described with reference to FIG. 12 and FIG. 13 as well as FIG. 1. FIG. 12 and FIG. 13 are cross-sectional views of the liquid crystal display according to another exemplary embodiment of the present invention taken along the lines II-II and III-III of FIG. 1.

The liquid crystal display according to the exemplary embodiment shown in FIG. 1, FIG. 12, and FIG. 13 is

similar to the liquid crystal display according to the exemplary embodiment shown in FIG. 1, FIG. 2, and FIG. 3A. Accordingly, the description of similar portions is omitted.

In contrast to the liquid crystal display according to the exemplary embodiment shown in FIG. 1, FIG. 2, and FIG. 3A, in the liquid crystal display according to the present exemplary embodiment, the color filters 230A, 230B, and 203C of two pixels neighboring with respect to the data line 171 do not overlap, and the light blocking member 220 is disposed between two neighboring color filters 230A, 230B, and 203C. Also, the width of the second portion of the common voltage line 171 disposed at the position corresponding to the data line 171 may be almost equal to that of the data line 171. Also, the liquid crystal display according to the present exemplary embodiment further includes the third passivation layer 180z between the color filters 230A, 230B, and 203C and the light blocking member 220, and the common electrode 131. The third passivation layer 180z may be made of the organic material and may have a flat surface. The third passivation layer 180z is disposed between the data line 171 and the common voltage line 301 such that the parasitic capacitance is decreased between the data line 171 and the common voltage line 301, thereby reducing the signal delay of the data line 171. The third passivation layer 180z reduces a step—formed by the overlapping of the color filters 230A, 230B, and 203C disposed in the neighboring pixels, and thereby the alignment layer 11 may be uniformly rubbed. However, the third passivation layer 180z may be an inorganic insulating layer and may prevent the component of the color filter from being exposed, and at this time, the third passivation layer 180z is formed at a lower temperature than the gate insulating layer 140 such that the deformation and the color change of the color filters 230A, 230B, and 203C may be prevented. Also, the third passivation layer 180z may reduce the transmittance loss according to the refractive index difference between the underlying color filter and the organic insulator.

All characteristics of the liquid crystal display according to the exemplary embodiment shown in FIG. 1, FIG. 2, and FIG. 3A may be applied to the liquid crystal display according to the present exemplary embodiment. Also, the characteristics and the effects of the several constituent elements according to the above-described exemplary embodiment may be applied to the present exemplary embodiment having the same constituent elements.

Next, the liquid crystal display according to another exemplary embodiment of the present invention will be described with reference to FIG. 14 and FIG. 15 as well as FIG. 1. FIG. 14 and FIG. 15 are cross-sectional views of the liquid crystal display according to another exemplary embodiment of the present invention taken along the lines II-II and III-III of FIG. 1.

The liquid crystal display according to the exemplary embodiment shown in FIG. 1, FIG. 14, and FIG. 15 is similar to the liquid crystal display according to the exemplary embodiment shown in FIG. 1, FIG. 2, and FIG. 3A. Accordingly, the description of similar portions is omitted.

In contrast to the liquid crystal display according to the exemplary embodiment shown in FIG. 1, FIG. 2, and FIG. 3A, the liquid crystal display according to the present exemplary embodiment further includes the light blocking member 220 disposed in the upper panel 200. The light blocking member 220 may prevent light from passing through the side of the common voltage line 301.

When the light blocking member 220 does not exist, outer light may be reflected from the common voltage line 301, and to prevent the reflected light, the width of the light

blocking member 220 should be greater than the width of the common voltage line 301. At this time, when assembling the upper panel 200 and the lower panel 100, when considering a misalignment, the width of the light blocking member should be greater than the width of the common voltage line 301. For example, when a range of the misalignment is about  $-2\ \mu\text{m}$  to  $+2\ \mu\text{m}$ , the width of the light blocking member 220 should be greater than the width of the common voltage line 301 by about  $4\ \mu\text{m}$ . However, when assembling the upper panel 200 and the lower panel 100, when the degree of misalignment is changed, the difference between the width of the light blocking member 220 and the width of the common voltage line 301 is also changed.

In detail, in the liquid crystal display according to the present exemplary embodiment, the width of the light blocking member 220 is greater than the width of the data line 171, and the width of the data line 171 may be equal to or greater than the width of the common voltage line 301.

In the case of the liquid crystal display according to an exemplary embodiment of the present invention, a color filter 230 is formed in the lower panel 100 such that the error range of the misalignment may be reduced compared with the case where the color filter 230 is disposed in the upper panel 200. According to the present exemplary embodiment, the line width of the light blocking member 220 of the liquid crystal display may be narrow compared with the case where the color filter 230 is disposed in the upper panel 200. In the case of the liquid crystal display according to the present exemplary embodiment, the common voltage line 301 disposed in the lower panel 100 functions as the light blocking member such that the width of the light blocking member 220 may be reduced as compared with the case where the common voltage line 301 does not exist.

In the case of the liquid crystal display according to another exemplary embodiment of the present invention, the common voltage line 301 may be formed of a conductive material. For example, the common voltage line 301 may be made of a conductive organic material having high electrical conductivity, and in this case, the reflection of the light may be prevented such that the light reflected into the side of the common voltage line 301 may be prevented without the light blocking member 220 of the upper panel 200. Accordingly, the aperture ratio of the liquid crystal display may be further improved.

All characteristics of the liquid crystal display according to the exemplary embodiment shown in FIG. 1, FIG. 2, and FIG. 3A may be applied to the liquid crystal display according to the present exemplary embodiment. Also, the characteristics and the effects of the several constituent elements according to the above-described exemplary embodiment may be applied to the present exemplary embodiment having the same constituent elements.

Next, the liquid crystal display according to another exemplary embodiment of the present invention will be described with reference to FIG. 16 and FIG. 17 as well as FIG. 1. FIG. 16 and FIG. 17 are cross-sectional views of the liquid crystal display according to another exemplary embodiment of the present invention taken along the lines II-II and III-III of FIG. 1.

The liquid crystal display according to the exemplary embodiment shown in FIG. 1, FIG. 16, and FIG. 17 is almost the same as the liquid crystal display according to the exemplary embodiment shown in FIG. 1, FIG. 2, and FIG. 3A. Accordingly, the description of similar portions is omitted.

In contrast to the liquid crystal display according to the exemplary embodiment shown in FIG. 1, FIG. 2, and FIG.

3A, the liquid crystal display according to the present exemplary embodiment includes the color filter 230 disposed in the upper panel 200, and the color filter is not disposed in the lower panel 100. In detail, the upper panel 200 includes the insulation substrate 210, and the light blocking member 220 and the color filter 230 formed on the insulation substrate 210. An overcoat 250 may be further formed on the light blocking member 220 and the color filter 230.

In the case of the lower panel 100, an organic layer 180 is disposed between the first passivation layer 180x and the common electrode 131. The surface of the organic layer 180 flat. At this time, the first passivation layer 180x may be omitted.

The light blocking member 220 may prevent the light from passing through the side of the common voltage line 301.

When the light blocking member 220 does not exist, outer light may be reflected from the common voltage line 301, and to prevent the reflected light, the width of the light blocking member 220 should be greater than the width of the common voltage line 301. At this time, when assembling the upper panel 200 and the lower panel 100, when considering a misalignment, the width should be greater than the width of the common voltage line 301, and for example, when a range of the misalignment is about  $-2\ \mu\text{m}$  to  $+2\ \mu\text{m}$ , the width of the light blocking member 220 should be greater than the width of the common voltage line 301 by about  $4\ \mu\text{m}$ . However, when assembling the upper panel 200 and the lower panel 100, when the degree of misalignment is changed, the difference between the width of the light blocking member 220 and the width of the common voltage line 301 is also changed.

In the liquid crystal display according to the present exemplary embodiment, the width of the light blocking member 220 is greater than the width of the data line 171, and the width of the data line 171 may be equal to or greater than the width of the common voltage line 301.

All characteristics of the liquid crystal display according to the exemplary embodiment shown in FIG. 1, FIG. 2, and FIG. 3A may be applied to the liquid crystal display according to the present exemplary embodiment. Also, the characteristics and the effects of the several constituent elements according to the above-described exemplary embodiment may be applied to the present exemplary embodiment having the same constituent elements.

Next, a liquid crystal display according to another exemplary embodiment of the present invention will be described with reference to FIG. 18 and FIG. 19. FIG. 18 and FIG. 19 are cross-sectional views of the liquid crystal display according to another exemplary embodiment of the present invention taken along the lines II-II and III-III of FIG. 1.

The liquid crystal display according to the exemplary embodiment shown in FIG. 1, FIG. 19, and FIG. 19 is almost the same as the liquid crystal display according to the exemplary embodiment shown in FIG. 1, FIG. 2, and FIG. 3A. Accordingly, the description of similar portions is omitted.

In contrast to the liquid crystal display according to the exemplary embodiment shown in FIG. 1, FIG. 2, and FIG. 3A, in the liquid crystal display according to the present exemplary embodiment, the common voltage line 301 is disposed under the common electrode 131 and directly contacts the common electrode 131.

In the liquid crystal displays according to the exemplary embodiments described with reference to FIG. 1 to FIG. 17, the common voltage line 301 is disposed above the common electrode 131.

All characteristics of the liquid crystal display according to the exemplary embodiment shown in FIG. 1, FIG. 2, and FIG. 3A may be applied to the liquid crystal display according to the present exemplary embodiment. Also, the characteristics and the effects of the several constituent elements according to the above-described exemplary embodiment may be applied to the present exemplary embodiment having the same constituent elements.

Next, a liquid crystal display according to another exemplary embodiment of the present invention will be described with reference to FIG. 20, FIG. 21, and FIG. 22. FIG. 20 is a layout view of a liquid crystal display according to another exemplary embodiment of the present invention, and FIG. 21 and FIG. 22 are cross-sectional views of the liquid crystal display taken along the lines XXI-XXI and XXII-XXII of FIG. 20.

The liquid crystal display according to the present exemplary embodiment includes a lower panel 100 and an upper panel 200 facing each other, and a liquid crystal layer 3 interposed between two display panels 100 and 200.

First, the lower panel 100 will be described. A plurality of gate lines 121, including a plurality of gate electrodes 124, are formed on an insulation substrate 110, and a gate insulating layer 140 is formed on the gate line 121. A plurality of semiconductors 151 including a plurality of protrusions 154 are formed on the gate insulating layer 140, and a plurality of ohmic contacts 161, 163, and 165 are formed on the semiconductor 151 and 154. A data conductor including a plurality of data lines 171 and a plurality of drain electrodes 175 is formed on the ohmic contacts 161, 163, and 165. The data line 171 is periodically bent and forms an oblique angle with respect to the extending direction of the gate line 121. The oblique angle between the data line 171 and the extending direction of the gate line 121 may be 45 degrees or more. However, in the case of a liquid crystal display according to another exemplary embodiment of the present invention, the data line 171 may be extended in a straight line.

A first passivation layer 180<sub>x</sub> is positioned on the data conductors 171 and 175 and the exposed semiconductor protrusion 154, and the first passivation layer 180<sub>x</sub> may be made of an organic insulating material or an inorganic insulating material.

A plurality of color filters 230A, 230B, and 230C are formed on the first passivation layer 180<sub>x</sub>. Each of the color filters 230A, 230B, and 230C may uniquely display one of primary colors, for example, three primary colors of red, green, and blue, or yellow, cyan, and magenta. Although not shown, the color filters may further include a color filter displaying a mixture of the primary colors or white, as well as the primary color. The color filters 230A, 230B, and 230C are made of an organic material. Each of the color filters 230A, 230B, and 230C may be extended to the data line 171, and two neighboring color filters 230A and 230B, or 230B and 230C, may overlap on the boundary of the data line 171.

A plurality of common electrodes 131 are formed on the color filters 230A, 230B, and 230C. The common electrodes 131 may be made of a transparent conductive material such as ITO or IZO. The common electrode 131 may have an opening 138 disposed on a region corresponding to the main edge of the drain electrode 175. The common electrodes 131 disposed in neighboring pixels are connected to each other. Each common electrode 131 includes a plurality of branch

electrodes 133 disposed in each pixel area. The branch electrodes 133 are substantially parallel to each other and may be bent according to the data line 171. However, in the case of a liquid crystal display according to another exemplary embodiment of the present invention, the data line 171 and the branch electrode 133 of the common electrode 131 may be extended in one straight line.

A common voltage line 301 is disposed on the common electrode 131 and directly contacts the common electrode 131. The common voltage line 301 includes a first portion parallel to the gate line 121 and a second portion parallel to the data line 171, and the first portion and the second portion are connected to each other. However, in the case of a liquid crystal display according to another exemplary embodiment of the present invention, at least one of the first portion and the second portion may be omitted.

The common voltage line 301 may be made of a metal that is opaque and has conductivity, in contrast to the common electrode 131. Also, the second portion of the common voltage line 301 disposed on the data line 171 may have a width that is equal to or greater than that of the data line 171, thereby preventing light leakage between two neighboring pixels with respect to the data line 171. Accordingly, a light blocking member between two neighboring pixels with respect to the data line 171 may be omitted.

The common electrode 131 and the common voltage line 301 may be simultaneously formed through one photolithography process using one mask. In detail, after the first conductive layer 130 forming the common electrode 131 and the second conductive layer 300 that is opaque and forming the common voltage line 301 are sequentially deposited, the first photosensitive film pattern has different thicknesses according to positions. Next, after the second conductive layer and the first conductive layer are simultaneously etched by using the first photosensitive film pattern as an etching mask, the height of the first photosensitive film pattern is decreased and simultaneously the thin photosensitive film pattern is removed to form the second photosensitive film pattern. The second conductive layer is etched by using the second photosensitive film pattern as the etching mask such that the common electrode 131 and the common voltage line 301 may be formed through one photolithography process.

A second passivation layer 180<sub>y</sub> is disposed on the common electrode 131 and the common voltage line 301. The second passivation layer 180<sub>y</sub> may be made of organic insulating material or inorganic insulating material.

A pixel electrode 191 is formed on the second passivation layer 180<sub>y</sub>. The pixel electrode 191 may have a plane shape filling most of the region enclosed by the gate line 121 and the data line 171. The entire shape of the pixel electrode 191 may be a polygon having edges substantially parallel to the gate line 121 and the data line 171. The pixel electrode 191 may be made of a transparent conductive material such as ITO or IZO.

The first passivation layer 180<sub>x</sub>, the color filter 230B, and the second passivation layer 180<sub>y</sub> have a plurality of contact holes 183 exposing the drain electrode 175, and the pixel electrode 191 is electrically connected to the drain electrode 175 through the contact hole 183, thereby receiving a data voltage.

The contact hole 183 is formed at a position corresponding to the opening 138 of the common electrode 131.

The data voltage applied to the pixel electrode 191 and the common voltage applied to the common electrode 131 generates an electric field to the liquid crystal layer 3.

The branch electrode **133** of the common electrode **131** overlaps the pixel electrode **191**.

In the case of the liquid crystal display according to the present exemplary embodiment, the common electrode **131** covers a plurality of data lines **171** at one time and overlaps the data line **171**. Accordingly, crosstalk is reduced between the data line **171** and the pixel electrode **191** and light leakage by a parasitic capacitance between the data line **171** and the neighboring pixel electrode **191** may be reduced.

A first alignment layer **11** is coated on an inner surface of the lower panel **100**.

Next, the upper panel **200** will be described.

A second alignment layer **21** is coated on an insulation substrate **210**.

The first alignment layer **11** and the second alignment layer **21** may be horizontal alignment layers.

The liquid crystal layer **3** interposed between the lower panel **100** and the upper panel **200** includes liquid crystal molecules, wherein the liquid crystal molecules may be aligned so that a major axis thereof is formed to be horizontal with respect to the surfaces of the two display panels **100** and **200** in the state where an electric field is not present.

A backlight unit (not shown) generating and providing light to the two display panels **100** and **200** may be provided outside the substrate **110** of the lower panel **100**.

The data voltage applied to the pixel electrode **191** generates an electric field in the liquid crystal layer **3** together with the common voltage applied to the electrode **131**, thereby determining the direction of the liquid crystal molecules of the liquid crystal layer **3** and displaying a corresponding image.

The liquid crystal display according to the present exemplary embodiment includes the common voltage line **301** disposed directly on the common electrode **131** and extending according to the gate line **121** or the data line **171**. Accordingly, the signal delay of the common voltage applied to the common electrode **131** is simultaneously prevented, the contact hole to connect the common electrode **131** and the common voltage line **301** is not needed, and the common voltage line **301** overlaps the opaque signal lines **121** and **171** such that the aperture ratio of the liquid crystal display is increased.

Also, the liquid crystal display according to the present exemplary embodiment includes the common electrode **131** covering the data line **171** such that the crosstalk between the data line **171** and the pixel electrode **191** may be reduced by the common electrode **131** and the light leakage by the parasitic capacitance between the data line **171** and the neighboring pixel electrode **191** may be reduced. Also, the liquid crystal display according to the present exemplary embodiment includes the common voltage line **301** having the width that is equal to or greater than the data line **171** such that the light leakage between two neighboring pixels with respect to the data line **171** may be prevented, and the additional light blocking member may be omitted, and thereby the aperture ratio of the liquid crystal display may be increased and the manufacturing cost may be reduced.

All characteristics of the liquid crystal display according to the exemplary embodiment shown in FIG. 1, FIG. 2, and FIG. 3A may be applied to the liquid crystal display according to the present exemplary embodiment. Also, the characteristics and the effects of the several constituent elements according to the above-described exemplary embodiment may be applied to the present exemplary embodiment having the same constituent elements.

Next, a liquid crystal display according to another exemplary embodiment of the present invention will be described

with reference to FIG. 23 and FIG. 24 as well as FIG. 20. FIG. 23 and FIG. 24 are cross-sectional views of the liquid crystal display according to another exemplary embodiment of the present invention taken along the lines XXI-XXI and XXII-XXII of FIG. 20.

The liquid crystal display according to the exemplary embodiment shown in FIG. 20, FIG. 23, and FIG. 24 is almost the same as the liquid crystal display according to the exemplary embodiment shown in FIG. 20, FIG. 21, and FIG. 22. Accordingly, the description of similar portions is omitted.

In contrast to the liquid crystal display according to the exemplary embodiment shown in FIG. 20, FIG. 21, and FIG. 22, in the liquid crystal display according to the present exemplary embodiment, a color filter **230** is disposed in the upper panel **200**. In detail, the upper panel **200** includes an insulation substrate **210**, and a light blocking member **220** and a color filter **230** formed on the insulation substrate **210**. An overcoat **250** may be further formed on the light blocking member **220** and the color filter **230**.

In the case of the lower panel **100**, an organic layer **180** is disposed between the first passivation layer **180x** and the common electrode **131**. The surface of the organic layer **180** is flat. The first passivation layer **180x** may be omitted.

When the light blocking member **220** does not exist, outer light may be reflected from the common voltage line **301**, and to prevent the reflected light, the width of the light blocking member **220** should be greater than the width of the common voltage line **301**. At this time, when assembling the upper panel **200** and the lower panel **100**, when considering a misalignment, the width of the light blocking member **220** should be greater than the width of the common voltage line **301**. For example, when a range of the misalignment is about  $-2\ \mu\text{m}$  to  $+2\ \mu\text{m}$ , the width of the light blocking member **220** should be greater than the width of the common voltage line **301** by about  $4\ \mu\text{m}$ . However, when assembling the upper panel **200** and the lower panel **100**, when the degree of misalignment is changed, the difference between the width of the light blocking member **220** and the width of the common voltage line **301** is also changed.

In the liquid crystal display according to the present exemplary embodiment, the width of the light blocking member **220** is greater than the width of the data line **171** and the width of the data line **171** may be equal to or wider than the width of the common voltage line **301**.

All characteristics of the liquid crystal display according to the exemplary embodiment shown in FIG. 1, FIG. 2, and FIG. 3A and the liquid crystal display according to the exemplary embodiment shown in FIG. 20, FIG. 21, and FIG. 22 may be applied to the liquid crystal display according to the present exemplary embodiment. Also, the characteristics and the effects of the several constituent elements according to the above-described exemplary embodiment may be applied to the present exemplary embodiment having the same constituent elements.

Next, a liquid crystal display according to another exemplary embodiment of the present invention will be described with reference to FIG. 25, FIG. 26, and FIG. 27. FIG. 25 is a layout view of a liquid crystal display according to another exemplary embodiment of the present invention, and FIG. 26 and FIG. 27 are cross-sectional views of the liquid crystal display taken along the lines XXVI-XXVI and XXVII-XXVII of FIG. 25.

The liquid crystal display according to the present exemplary embodiment includes a lower panel **100** and an upper panel **200** facing each other, and a liquid crystal layer **3** interposed between the two display panels **100** and **200**.

First, the lower panel **100** will be described. A plurality of gate lines **121**, including a plurality of gate electrodes **124**, are formed on an insulation substrate **110**, and a gate insulating layer **140** is formed on the gate line **121**. A plurality of semiconductors **151** including a plurality of protrusions **154** are formed on the gate insulating layer **140**, and a plurality of ohmic contacts **161**, **163**, and **165** are formed on the semiconductors **151** and **154**. A data conductor including a plurality of data lines **171** and a plurality of drain electrodes **175** is formed on the ohmic contacts **161**, **163**, and **165**. The data line **171** is periodically bent and forms an oblique angle by the extending direction of the gate line **121**. The oblique angle between the data line **171** and the extending direction of the gate line **121** may be 45 degrees or more. However, in the case of the liquid crystal display according to another exemplary embodiment of the present invention, the data line **171** may be extended in a straight line.

The first passivation layer **180x** is positioned on the data conductors **171** and **175** and the exposed semiconductor protrusion **154**, and the first passivation layer **180x** may be made of the organic insulating material or the inorganic insulating material.

A plurality of color filters **230A**, **230B**, and **230C** are formed on the first passivation layer **180x**. Each of the color filters **230A**, **230B**, and **230C** may uniquely display one of primary colors, for example, three primary colors of red, green, and blue or yellow, cyan, and magenta. Although not shown, the color filters may further include a color filter displaying a mixture of the primary colors or white, as well as the primary color. The color filters **230A**, **230B**, and **230C** are made of the organic material. Each of the color filters **230A**, **230B**, and **230C** may be extended to the data line **171**, and two neighboring color filters **230A** and **230B**, or **230B** and **230C**, may overlap on the boundary of the data line **171**.

A plurality of pixel electrodes **191** are formed on the color filters **230A**, **230B**, and **230C**. The pixel electrode **191** may have a plane shape filling most of the region enclosed by the gate line **121** and the data line **171**. The entire shape of the pixel electrode **191** may be a polygon having edges substantially parallel to the gate line **121** and the data line **171**. The pixel electrode **191** may be made of the transparent conductive material such as ITO or IZO.

The first passivation layer **180x** and the color filter **230B** have a plurality of contact holes **183** exposing the drain electrode **175**, and the pixel electrode **191** is electrically connected to the drain electrode **175** through the contact hole **183**, thereby receiving a data voltage.

The second passivation layer **180y** is formed on the color filters **230A**, **230B**, and **230C** and the pixel electrode **191**. The second passivation layer **180y** may include the organic insulator or the inorganic insulator.

A common electrode **131** is formed on the second passivation layer **180y**. The common electrode **131** may be made of the transparent conductive material such as ITO or IZO. The common electrodes **131** disposed in neighboring pixels are connected to each other. The common electrode **131** includes a plurality of branch electrodes **133** disposed in each pixel area. The branch electrodes **133** are substantially parallel to each other and may be bent according to the data line **171**. However, in the case of a liquid crystal display according to another exemplary embodiment of the present invention, the data line **171** and the branch electrode **133** of the common electrode **131** may be extended in one straight line.

The branch electrode **133** of the common electrode **131** overlaps the pixel electrode **191**.

The common voltage line **301** is disposed on the common electrode **131** and directly contacts the common electrode **131**. The common voltage line **301** includes a first portion parallel to the gate line **121** and a second portion parallel to the data line **171**, and the first portion and the second portion are connected to each other. However, in the case of a liquid crystal display according to another exemplary embodiment of the present invention, at least one of the first portion and the second portion may be omitted.

The common voltage line **301** may be made of a metal that is opaque and has conductivity, in contrast to the common electrode **131**. Also, the second portion of the common voltage line **301** disposed on the data line **171** may have a width that is equal to or greater than the data line **171**, thereby preventing light leakage between two pixels neighboring with respect to the data line **171**. Accordingly, a light blocking member between two neighboring pixels with respect to the data line **171** may be omitted.

The common electrode **131** and the common voltage line **301** may be simultaneously formed through one photolithography process using one mask. In detail, after the first conductive layer **130** forming the common electrode **131** and the second conductive layer **300** that is opaque and forming the common voltage line **301** are sequentially deposited on the substrate **110**, the first photosensitive film pattern having different thicknesses according to positions is formed. Next, after the second conductive layer **300** and the first conductive layer **130** are simultaneously etched by using the first photosensitive film pattern as an etching mask, the height of the first photosensitive film pattern is decreased and simultaneously the thin photosensitive film pattern is removed to form the second photosensitive film pattern. The second conductive layer **300** is etched by using the second photosensitive film pattern as the etching mask such that the common electrode **131** and the common voltage line **301** may be formed through one photolithography process.

The data voltage applied to the pixel electrode **191** and the common voltage applied to the common electrode **131** generates an electric field to the liquid crystal layer **3**.

In the case of the liquid crystal display according to the present exemplary embodiment, the common electrode **131** covers a plurality of data lines **171** at one time and overlaps the data line **171**. Accordingly, crosstalk is reduced between the data line **171** and the pixel electrode **191** and light leakage by a parasitic capacitance between the data line **171** and the neighboring pixel electrode **191** may be reduced.

The first alignment layer **11** is coated on an inner surface of the lower panel **100**.

Next, the upper panel **200** will be described.

The second alignment layer **21** is coated on an insulation substrate **210**.

The first alignment layer **11** and the second alignment layer **21** may be horizontal alignment layers.

The liquid crystal layer **3** interposed between the lower panel **100** and the upper panel **200** includes liquid crystal molecules, wherein the liquid crystal molecules may be aligned so that a major axis thereof is formed to be horizontal with respect to the surfaces of the two display panels **100** and **200** in the state where an electric field is not present.

A backlight unit (not shown) generating and providing light to the two display panels **100** and **200** may be provided outside the substrate **110** of the lower panel **100**.

The data voltage applied to the pixel electrode **191** generates an electric field in the liquid crystal layer **3** together with the common voltage applied to the common electrode **131**, thereby determining the direction of the

liquid crystal molecules of the liquid crystal layer 3 and displaying a corresponding image.

The liquid crystal display according to the present exemplary embodiment includes the common voltage line 301 disposed directly on the common electrode 131 and extending according to the gate line 121 or the data line 171. Accordingly, the signal delay of the common voltage applied to the common electrode 131 is simultaneously prevented, the contact hole to connect the common electrode 131 and the common voltage line 301 is not needed, and the common voltage line 301 overlaps the opaque signal lines 121 and 171 such that the aperture ratio of the liquid crystal display is increased.

Also, the liquid crystal display according to the present exemplary embodiment includes the common electrode 131 covering the data line 171 such that the crosstalk between the data line 171 and the pixel electrode 191 may be reduced by the common electrode 131 and the light leakage caused by the parasitic capacitance between the data line 171 and the neighboring pixel electrode 191 may be reduced. Also, the liquid crystal display according to the present exemplary embodiment includes the common voltage line 301 having a width that is greater than the data line 171 such that the light leakage between two neighboring pixels with respect to the data line 171 may be prevented, and the additional light blocking member may be omitted. Thereby, the aperture ratio of the liquid crystal display may be increased and the manufacturing cost may be reduced.

Next, a liquid crystal display according to another exemplary embodiment of the present invention will be described with reference to FIG. 28 and FIG. 29 as well as FIG. 25. FIG. 28 and FIG. 29 are cross-sectional views of the liquid crystal display according to another exemplary embodiment of the present invention taken along the lines XXI-XXI and XXII-XXII of FIG. 25.

The liquid crystal display according to the exemplary embodiment shown in FIG. 25, FIG. 28, and FIG. 29 is almost the same as the liquid crystal display according to the exemplary embodiment shown in FIG. 25, FIG. 26, and FIG. 27. Accordingly, the description of similar portions is omitted.

In contrast to the liquid crystal display according to the exemplary embodiment shown in FIG. 20, FIG. 21, and FIG. 22, the liquid crystal display according to the present exemplary embodiment further includes the third passivation layer 180z between the color filters 230A, 230B, and 230C and the pixel electrode 191. The third passivation layer 180z is disposed between the data line 171 and the common voltage line 301 such that the parasitic capacitance is decreased between the data line 171 and the common voltage line 301, thereby reducing the signal delay of the data line 171. The third passivation layer 180z may be made of the organic material and may have a flat surface. The third passivation layer 180z reduces a step formed by the overlapping of the color filters 230A, 230B, and 230C disposed in the neighboring pixels, and thereby the alignment layer 11 may be uniformly rubbed. However, the third passivation layer 180z may be an inorganic insulating layer and may prevent the component of the color filter from being exposed, and the third passivation layer 180z is formed at a lower temperature than the gate insulating layer 140 such that deformation and color change of the color filters 230A, 230B, and 230C may be prevented. Also, the third passivation layer 180z may reduce the transmittance loss according to the refractive index difference between the underlying color filter and the organic insulator.

All characteristics of the liquid crystal display according to the exemplary embodiment shown in FIG. 25, FIG. 26, and FIG. 27 may be applied to the liquid crystal display according to the present exemplary embodiment. Also, the characteristics and the effects of the several constituent elements according to the above-described exemplary embodiment may be applied to the present exemplary embodiment having the same constituent elements.

Next, a liquid crystal display according to another exemplary embodiment of the present invention will be described with reference to FIG. 30 and FIG. 31 as well as FIG. 25. FIG. 30 and FIG. 31 are cross-sectional views of the liquid crystal display according to another exemplary embodiment of the present invention taken along the lines XXVI-XXVI and XXVII-XXVII of FIG. 25.

The liquid crystal display according to the exemplary embodiment shown in FIG. 25, FIG. 30, and FIG. 31 is almost the same as the liquid crystal display according to the exemplary embodiment shown in FIG. 25, FIG. 26, and FIG. 27. Accordingly, the description of similar portions is omitted.

In contrast to the liquid crystal display according to the exemplary embodiment shown in FIG. 25, FIG. 26, and FIG. 27, the liquid crystal display according to the present exemplary embodiment further includes the third passivation layer 180z between the color filters 230A, 230B, and 230C and the common electrode 131, and the third passivation layer 180z includes a lower layer 180zp and an upper layer 180zq. The lower layer 180zp of the third passivation layer 180z may be an inorganic insulating layer, and prevents the component of the color filter from being exposed outside. The upper layer 180zq of the third passivation layer 180z may be made of organic material and may have a flat surface. The lower layer 180zp of the third passivation layer 180z is formed at a lower temperature than the gate insulating layer 140 such that the deformation and the color change of the color filters 230A, 230B, and 230C may be prevented, and may reduce the transmittance loss according to the refractive index difference between the underlying color filter and the organic insulator. The upper layer 180zq of the third passivation layer 180z may be an organic insulator and reduce the step caused by the overlapping of the color filters 230A, 230B, and 230C disposed in the neighboring pixels, and thereby the alignment layer 11 may be uniformly rubbed. The third passivation layer 180z is disposed between the data line 171 and the common voltage line 301 such that the parasitic capacitance is decreased between the data line 171 and the common voltage line 301, thereby reducing the signal delay of the data line 171.

In the liquid crystal display according to the present exemplary embodiment, the lower layer 180zp of the third passivation layer 180z is the inorganic insulating layer and the upper layer 180zq is the organic insulator, however in a liquid crystal display according to another exemplary embodiment of the present invention, the lower layer 180zp of the third passivation layer 180z may be the organic insulator and the upper layer 180zq may be the inorganic insulating layer.

All characteristics of the liquid crystal display according to the exemplary embodiment shown in FIG. 25, FIG. 26, and FIG. 27 may be applied to the liquid crystal display according to the present exemplary embodiment. Also, the characteristics and the effects of the several constituent elements according to the above-described exemplary embodiment may be applied to the present exemplary embodiment having the same constituent elements.

Next, the liquid crystal display according to another exemplary embodiment of the present invention will be described with reference to FIG. 32 and FIG. 33 as well as FIG. 25. FIG. 32 and FIG. 33 are cross-sectional views of the liquid crystal display according to another exemplary embodiment of the present invention taken along the lines XXVI-XXVI and XXVII-XXVII of FIG. 25.

The liquid crystal display according to the exemplary embodiment shown in FIG. 25, FIG. 32, and FIG. 33 is similar to the liquid crystal display according to the exemplary embodiment shown in FIG. 25, FIG. 26, and FIG. 27. Accordingly, the description of similar portions is omitted.

In contrast to the liquid crystal display according to the exemplary embodiment shown in FIG. 25, FIG. 26, and FIG. 27, the liquid crystal display according to the present exemplary embodiment further includes the third passivation layer 180z between the color filters 230A, 230B, and 230C and the common electrode 131, and the third passivation layer 180z is only disposed at a portion corresponding to a portion where the common voltage line 301 is disposed. The third passivation layer 180z may be made of organic material or inorganic material and may have a flat surface. In this way, the third passivation layer 180z is disposed in the portion corresponding to the portion where the common voltage line 301 is disposed such that the third passivation layer 180z is not formed in the display area (e.g., the area where the pixel electrode 191 is formed) displaying the image. Thereby, the absorption of light of the backlight by the third passivation layer 180z including the organic material may be reduced and the reduction of transmittance may be prevented. The third passivation layer 180z is disposed between the data line 171 and the common voltage line 301 such that the parasitic capacitance is decreased between the data line 171 and the common voltage line 301, thereby reducing the signal delay of the data line 171.

All characteristics of the liquid crystal display according to the exemplary embodiment shown in FIG. 25, FIG. 26, and FIG. 27 may be applied to the liquid crystal display according to the present exemplary embodiment. Also, the characteristics and the effects of the several constituent elements according to the above-described exemplary embodiment may be applied to the present exemplary embodiment having the same constituent elements.

Next, a liquid crystal display according to another exemplary embodiment of the present invention will be described with reference to FIG. 34 and FIG. 35 as well as FIG. 25. FIG. 34 and FIG. 35 are cross-sectional views of the liquid crystal display according to another exemplary embodiment of the present invention taken along the lines XXVI-XXVI and XXVII-XXVII of FIG. 25.

The liquid crystal display according to the exemplary embodiment shown in FIG. 25, FIG. 34, and FIG. 35 is similar to the liquid crystal display according to the exemplary embodiment shown in FIG. 25, FIG. 26, and FIG. 27. Accordingly, the description of similar portions is omitted.

In contrast to the liquid crystal display according to the exemplary embodiment shown in FIG. 25, FIG. 26, and FIG. 27, in the liquid crystal display according to the present exemplary embodiment, the color filters 230A, 230B, and 203C of two neighboring pixels with respect to the data line 171 do not overlap and the light blocking member 220 is disposed between two neighboring color filters 230A, 230B, and 203C. Also, the width of the second portion of the common voltage line 301 disposed at the position corresponding to the data line 171 may be almost equal to that of the data line 171.

All characteristics of the liquid crystal display according to the exemplary embodiment shown in FIG. 25, FIG. 26, and FIG. 27 may be applied to the liquid crystal display according to the present exemplary embodiment. Also, the characteristics and the effects of the several constituent elements according to the above-described exemplary embodiment may be applied to the present exemplary embodiment having the same constituent elements.

Next, a liquid crystal display according to another exemplary embodiment of the present invention will be described with reference to FIG. 36 and FIG. 37 as well as FIG. 25. FIG. 36 and FIG. 37 are cross-sectional views of the liquid crystal display according to another exemplary embodiment of the present invention taken along the lines XXVI-XXVI and XXVII-XXVII of FIG. 25.

The liquid crystal display according to the exemplary embodiment shown in FIG. 25, FIG. 36, and FIG. 37 is similar to the liquid crystal display according to the exemplary embodiment shown in FIG. 25, FIG. 26, and FIG. 27. Accordingly, the description of similar portions is omitted.

In contrast to the liquid crystal display according to the exemplary embodiment shown in FIG. 25, FIG. 26, and FIG. 27, in the liquid crystal display according to the present exemplary embodiment, the color filters 230A, 230B, and 203C of two neighboring pixels with respect to the data line 171 do not overlap and the light blocking member 220 is disposed between two neighboring color filters 230A, 230B, and 203C. Also, the width of the second portion of the common voltage line 301 disposed at a position corresponding to the data line 171 may be almost equal to that of the data line 171. Also, the liquid crystal display according to the present exemplary embodiment further includes the third passivation layer 180z arranged between the color filters 230A, 230B, and 203C and the light blocking member 220, and the common electrode 131. The third passivation layer 180z may be made of organic material and may have a flat surface. The third passivation layer 180z is disposed between the data line 171 and the common voltage line 301 such that the parasitic capacitance is decreased between the data line 171 and the common voltage line 301, thereby reducing the signal delay of the data line 171. The third passivation layer 180z reduces a step formed by the overlapping of the color filters 230A, 230B, and 203C disposed in the neighboring pixels, and thereby the alignment layer 11 may be uniformly rubbed. However, the third passivation layer 180z may be an inorganic insulating layer and may prevent the component of the color filter from being exposed, and the third passivation layer 180z is formed at a lower temperature than the gate insulating layer 140 such that deformation and color change of the color filters 230A, 230B, and 203C may be prevented. Also, the third passivation layer 180z may reduce the transmittance loss according to the refractive index difference between the underlying color filter and the organic insulator.

All characteristics of the liquid crystal display according to the exemplary embodiment shown in FIG. 25, FIG. 26, and FIG. 27 may be applied to the liquid crystal display according to the present exemplary embodiment. Also, the characteristics and the effects of the several constituent elements according to the above-described exemplary embodiment may be applied to the present exemplary embodiment having the same constituent elements.

Next, a liquid crystal display according to another exemplary embodiment of the present invention will be described with reference to FIG. 38 and FIG. 39 as well as FIG. 25. FIG. 38 and FIG. 39 are cross-sectional views of the liquid crystal display according to another exemplary embodiment

of the present invention taken along the lines XXVI-XXVI and XXVII-XXVII of FIG. 25.

The liquid crystal display according to the exemplary embodiment shown in FIG. 25, FIG. 38, and FIG. 39 is similar to the liquid crystal display according to the exemplary embodiment shown in FIG. 25, FIG. 26, and FIG. 27. Accordingly, the description of similar portions is omitted.

In contrast to the liquid crystal display according to the exemplary embodiment shown in FIG. 25, FIG. 26, and FIG. 27, the liquid crystal display according to the present exemplary embodiment further includes the light blocking member 220 disposed in the upper panel 200. The light blocking member 220 may prevent the light from passing through the side of the common voltage line 301.

When the light blocking member 220 does not exist, outer light may be reflected from the common voltage line 301, and to prevent reflected light, the width of the light blocking member 220 should be greater than the width of the common voltage line 301. At this time, when assembling the upper panel 200 and the lower panel 100, when considering a misalignment, the width should be greater than the width of the common voltage line 301. For example, when a range of the misalignment is about  $-2\ \mu\text{m}$  to  $+2\ \mu\text{m}$ , the width of the light blocking member 220 should be greater than the width of the common voltage line 301 by about  $4\ \mu\text{m}$ . However, when assembling the upper panel 200 and the lower panel 100, when the degree of misalignment is changed, the difference between the width of the light blocking member 220 and the width of the common voltage line 301 is also changed.

In the liquid crystal display according to the present exemplary embodiment, the width of the light blocking member 220 is greater than the width of the data line 171, and the width of the data line 171 may be equal to or greater than the width of the common voltage line 301.

In the case of a liquid crystal display according to an exemplary embodiment of the present invention, the color filter 230 is formed in the lower panel 100 such that the error range of the misalignment may be reduced as compared to the case where the color filter 230 is disposed in the upper panel 200. According to the present exemplary embodiment, the line width of the light blocking member 220 of the liquid crystal display may be narrow compared to the case where the color filter 230 is disposed in the upper panel 200. In the case of the liquid crystal display according to the present exemplary embodiment, the common voltage line 301 disposed in the lower panel 100 functions as a light blocking member such that the width of the light blocking member 220 may be reduced compared with the case where the common voltage line 301 does not exist.

In the case of a liquid crystal display according to another exemplary embodiment of the present invention, the common voltage line 301 may be formed of a conductive material. For example, the common voltage line 301 may be made of a conductive organic material having high electrical conductivity, and in this case, the reflection of light may be prevented such that the light reflected into the side of the common voltage line 301 may be prevented without the light blocking member 220 of the upper panel 200. Accordingly, the aperture ratio of the liquid crystal display may be further increased.

All characteristics of the liquid crystal display according to the exemplary embodiment shown in FIG. 25, FIG. 26, and FIG. 27 may be applied to the liquid crystal display according to the present exemplary embodiment. Also, the characteristics and the effects of the several constituent elements according to the above-described exemplary

embodiment may be applied to the present exemplary embodiment having the same constituent elements.

Next, a liquid crystal display according to another exemplary embodiment of the present invention will be described with reference to FIG. 40 and FIG. 41 as well as FIG. 25. FIG. 40 and FIG. 41 are cross-sectional views of the liquid crystal display according to another exemplary embodiment of the present invention taken along the lines XXVI-XXVI and XXVII-XXVII of FIG. 25.

The liquid crystal display according to the exemplary embodiment shown in FIG. 25, FIG. 40, and FIG. 41 is almost the same as the liquid crystal display according to the exemplary embodiment shown in FIG. 25, FIG. 26, and FIG. 27. Accordingly, the description of similar portions is omitted.

In contrast to the liquid crystal display according to the exemplary embodiment shown in FIG. 25, FIG. 26, and FIG. 27, the liquid crystal display according to the present exemplary embodiment includes the color filter 230 disposed in the upper panel 200. In detail, the upper panel 200 includes the insulation substrate 210, and the light blocking member 220 and the color filter 230 formed on the insulation substrate 210. An overcoat 250 may be further formed on the light blocking member 220 and the color filter 230.

In the case of the lower panel 100, an organic layer 180 is disposed between the first passivation layer 180x and the common electrode 131. The surface of the organic layer 180 is flat. The first passivation layer 180x may be omitted.

The light blocking member 220 may prevent the light from passing through the side of the common voltage line 301.

When the light blocking member 220 does not exist, the outer light may be reflected from the common voltage line 301, and to prevent the reflected light, the width of the light blocking member 220 should be greater than the width of the common voltage line 301. At this time, when assembling the upper panel 200 and the lower panel 100, when considering a misalignment, the width should be greater than the width of the common voltage line 301. For example, when a range of the misalignment is about  $-2\ \mu\text{m}$  to  $+2\ \mu\text{m}$ , the width of the light blocking member 220 should be greater than the width of the common voltage line 301 by about  $4\ \mu\text{m}$ . However, when assembling the upper panel 200 and the lower panel 100, when the degree of misalignment is changed, the difference between the width of the light blocking member 220 and the width of the common voltage line 301 is also changed.

In the liquid crystal display according to the present exemplary embodiment, the width of the light blocking member 220 is greater than the width of the data line 171 and the width of the data line 171 may be equal to or greater than the width of the common voltage line 301.

All characteristics of the liquid crystal display according to the exemplary embodiment shown in FIG. 25, FIG. 26, and FIG. 27 may be applied to the liquid crystal display according to the present exemplary embodiment. Also, the characteristics and the effects of the several constituent elements according to the above-described exemplary embodiment may be applied to the present exemplary embodiment having the same constituent elements.

Next, a liquid crystal display according to another exemplary embodiment of the present invention will be described with reference to FIG. 42 and FIG. 43 as well as FIG. 25. FIG. 42 and FIG. 43 are cross-sectional views of the liquid crystal display according to another exemplary embodiment of the present invention taken along the lines XXVI-XXVI and XXVII-XXVII of FIG. 25.

The liquid crystal display according to the exemplary embodiment shown in FIG. 25, FIG. 42, and FIG. 43 is almost the same as the liquid crystal display according to the exemplary embodiment shown in FIG. 25, FIG. 26, and FIG. 27. Accordingly, the description of similar portions is omitted.

In contrast to the liquid crystal display according to the exemplary embodiment shown in FIG. 25, FIG. 26, and FIG. 27, the common voltage line 301 covers the side of the common electrode 131. In this way, the width of the common voltage line 301 is formed to be large enough such that the light leakage according to the irregular movement of the liquid crystal molecules that may be generated on the circumference of the common electrode 131 may be prevented.

All characteristics of the liquid crystal display according to the exemplary embodiment shown in FIG. 25, FIG. 26, and FIG. 27 may be applied to the liquid crystal display according to the present exemplary embodiment. Also, the characteristics and the effects of the several constituent elements according to the above-described exemplary embodiment may be applied to the present exemplary embodiment having the same constituent elements.

Next, a liquid crystal display according to another exemplary embodiment of the present invention will be described with reference to FIG. 44 and FIG. 45 as well as FIG. 25. FIG. 44 and FIG. 45 are cross-sectional views of the liquid crystal display according to another exemplary embodiment of the present invention taken along the lines XXVI-XXVI and XXVII-XXVII of FIG. 25.

The liquid crystal display according to the exemplary embodiment shown in FIG. 25, FIG. 44, and FIG. 45 is almost the same as the liquid crystal display according to the exemplary embodiment shown in FIG. 25, FIG. 26, and FIG. 27. Accordingly, the description of similar portions is omitted.

In contrast to the liquid crystal display according to the exemplary embodiment shown in FIG. 25, FIG. 26, and FIG. 27, in the liquid crystal display according to the present exemplary embodiment, the common voltage line 301 is disposed under the common electrode 131 and directly contacts the common electrode 131.

In the liquid crystal displays according to the exemplary embodiments described with reference to FIG. 25 to FIG. 43, the common voltage line 301 may be disposed under the common electrode 131.

All characteristics of the liquid crystal display according to the exemplary embodiment shown in FIG. 25, FIG. 26, and FIG. 27 may be applied to the liquid crystal display according to the present exemplary embodiment. Also, the characteristics and the effects of the several constituent elements according to the above-described exemplary embodiment may be applied to the present exemplary embodiment having the same constituent elements.

Next, a liquid crystal display according to another exemplary embodiment of the present invention will be described with reference to FIG. 46, FIG. 47, FIG. 48, FIG. 49, and FIG. 50. FIG. 46, FIG. 47, FIG. 48, FIG. 49, and FIG. 50 are layout views of signal lines of a liquid crystal display according to an exemplary embodiment of the present invention.

Firstly, referring to FIG. 46, a data line 171 of a liquid crystal display according to an exemplary embodiment of the present invention may be bent at least once between two neighboring gate lines 121, and a common voltage line 301 is disposed at a position overlapping the gate line 121 and the data line 171. The common voltage line 301 has sub-

stantially the same plane shape as the gate line 121 and the data line 171, and extends according to the gate line 121 and the data line 171.

Referring to FIG. 47, a data line 171 of a liquid crystal display according to an exemplary embodiment of the present invention may be bent at least once between two neighboring gate lines 121, and a common voltage line 301 includes a first portion 301a overlapping the gate line 121 and a second portion 301b overlapping the data line 171. The first portion 301a of the common voltage line 301 overlaps all gate lines 121, and the second portion 301b is disposed on one of every three data lines 171 that are disposed neighboring each other. In this way, the connection of the common voltage line 301 may be disposed one by one per a plurality of pixels that are disposed neighboring each other.

Referring to FIG. 48, a data line 171 of a liquid crystal display according to an exemplary embodiment of the present invention may be bent at least once between two neighboring gate lines 121, and a common voltage line 301 includes the first portion 301a overlapping the gate line 121 and the second portion 301b overlapping the data line 171. The first portion 301a of the common voltage line 301 is disposed on one of every three gate lines 121 that are disposed neighboring each other, and the second portion 301b is disposed on one of every six data lines 171 that are disposed neighboring each other. In this way, the connection of the common voltage line 301 may be disposed on one per a plurality of pixels that are disposed neighboring each other.

Referring to FIG. 49, a data line 171 of a liquid crystal display according to an exemplary embodiment of the present invention may be bent at least once between two neighboring gate lines 121, and a common voltage line 301 includes the first portion 301a overlapping the gate line 121 and the second portion 301b overlapping the data line 171. The first portion 301a of the common voltage line 301 is disposed on one of every three gate lines 121 that are disposed neighboring each other, and the second portion 301b is only disposed at the position overlapping the data line 171 of the pixel disposed at the edge. In this way, the connection of the common voltage line 301 may be disposed on one per a plurality of pixels that are disposed neighboring each other.

Referring to FIG. 50, a data line 171 of a liquid crystal display according to an exemplary embodiment of the present invention may be bent at least once between two neighboring gate lines 121, and a common voltage line 301 includes the first portion 301a overlapping the gate line 121 and the second portion 301b overlapping the data line 171. The first portion 301a of the common voltage line 301 is only disposed at the position overlapping the gate line 131 of the pixel disposed at the edge, and the second portion 301b is disposed on one of every six data lines 171 that are disposed neighboring each other. In this way, the connection of the common voltage line 301 may be disposed on one per a plurality of pixels that are disposed neighboring each other.

However, the arrangement of the common voltage line 301 is not limited thereto and may be variously changed.

It will be apparent to those skilled in the art that various modifications and variations can be made in the present invention without departing from the spirit or scope of the invention. Thus, it is intended that the present invention cover the modifications and variations of this invention provided they come within the scope of the appended claims and their equivalents.

What is claimed is:

1. A liquid crystal display comprising:
  - a first substrate;

a gate line disposed on the first substrate;  
 a data line intersecting the gate line;  
 a thin film transistor connected to the gate line and the data line;  
 a pixel electrode connected to the thin film transistor;  
 a common electrode overlapping the pixel electrode via a first insulating layer; and  
 a common voltage line directly contacting the common electrode and having no layer interposed between the common voltage line and the common electrode,  
 wherein:  
 the pixel electrode comprises a branch electrode;  
 the common voltage line comprises a bent portion having an oblique angle with respect to an extending direction of the gate line;  
 the bent portion of the common voltage line directly contacts the common electrode; and  
 the bent portion of the common voltage line overlaps the data line.

2. The liquid crystal display of claim 1, wherein the width of the common voltage line is equal to or greater than the width of the data line.

3. The liquid crystal display of claim 2, wherein the common voltage line is disposed directly on or directly under the common electrode.

4. The liquid crystal display of claim 1, further comprising:  
 a color filter disposed on the first substrate; and  
 a light blocking member disposed between two neighboring color filters among the plurality of color filters and disposed at a position corresponding to the data line.

5. The liquid crystal display of claim 4, wherein the common voltage line is disposed directly on or directly under the common electrode.

6. The liquid crystal display of claim 1, further comprising:  
 a second substrate facing the first substrate;  
 a color filter disposed on the first substrate or the second substrate; and  
 a light blocking member disposed on the second substrate.

7. The liquid crystal display of claim 6, wherein the width of the common voltage line is equal to or less than the width of the data line.

8. The liquid crystal display of claim 7, wherein the width of the light blocking member is equal to or greater than the width of the data line.

9. The liquid crystal display of claim 7, wherein the common voltage line is disposed directly on or directly under the common electrode.

10. The liquid crystal display of claim 1, wherein the common voltage line is disposed directly on or directly under the common electrode.

11. A liquid crystal display comprising:  
 a first substrate;  
 a gate line and a data line disposed on the first substrate;  
 a thin film transistor connected to the gate line and the data line;  
 a common electrode disposed on the first substrate;  
 a common voltage line directly contacting the common electrode and having no layer interposed between the common voltage line and the common electrode;  
 a first insulating layer disposed on the common electrode; and  
 a pixel electrode disposed on the first insulating layer,  
 wherein:

the common electrode and the pixel electrode overlap each other, and at least one of the common electrode and the plurality of pixel electrodes comprises a branch electrode;  
 the common voltage line comprises a bent portion parallel to the data line and forms an oblique angle with respect to an extending direction of the gate line;  
 the bent portion of the common voltage line directly contacts the common electrode; and  
 the bent portion of the common voltage line overlaps the data line.

12. The liquid crystal display of claim 11, further comprising a plurality of color filters disposed on the first substrate,  
 wherein two neighboring color filters among the plurality of color filters overlap each other at a position corresponding to the data line.

13. The liquid crystal display of claim 12, wherein the common voltage line is disposed directly on or directly under the common electrode.

14. The liquid crystal display of claim 13, wherein the width of the common voltage line is equal to or greater than the width of the data line.

15. The liquid crystal display of claim 14, further comprising  
 a second insulating layer disposed between the plurality of color filters and the common electrode.

16. The liquid crystal display of claim 15, wherein the common voltage line comprises a first portion overlapping at least one of the plurality of gate lines and a second portion overlapping at least one of the plurality of data lines.

17. The liquid crystal display of claim 16, wherein the first portion of the common voltage line is disposed on one of every three neighboring gate lines among the plurality of gate lines.

18. The liquid crystal display of claim 16, wherein the second portion of the common voltage line is disposed on one of every three neighboring data lines among the plurality of data lines.

19. The liquid crystal display of claim 16, wherein the second portion of the common voltage line is disposed on one of every six neighboring data lines among the plurality of data lines.

20. The liquid crystal display of claim 11, further comprising  
 a light blocking member disposed between two neighboring color filters among a plurality of color filters and disposed at a position corresponding to the data line.

21. The liquid crystal display of claim 20, wherein the common voltage line is disposed directly on or directly under the common electrode.

22. The liquid crystal display of claim 21, further comprising  
 a second insulating layer disposed between the plurality of color filters and the common electrode.

23. The liquid crystal display of claim 11, further comprising:  
 a second substrate facing the first substrate; and  
 a light blocking member disposed on the second substrate.

24. The liquid crystal display of claim 23, wherein the width of the common voltage line is equal to or less than the width of the data line.

25. The liquid crystal display of claim 24, wherein the width of the light blocking member is equal to or greater than the width of the data line.

26. The liquid crystal display of claim 11, further comprising

a second insulating layer disposed between the plurality of color filters and the common electrode.

27. The liquid crystal display of claim 26, wherein the common voltage line comprises a first portion overlapping at least one of the plurality of gate lines and a second portion overlapping at least one of the plurality of data lines.

28. The liquid crystal display of claim 11, wherein the common voltage line is disposed directly on or directly under the common electrode.

29. The liquid crystal display of claim 28, wherein the common voltage line comprises a first portion overlapping at least one of the plurality of gate lines and a second portion overlapping at least one of the plurality of data lines.

\* \* \* \* \*

专利名称(译)	液晶显示器		
公开(公告)号	<a href="#">US9835915</a>	公开(公告)日	2017-12-05
申请号	US13/558156	申请日	2012-07-25
[标]申请(专利权)人(译)	金成勋 廉JOO SEOK RYU KYU WAN CHOI SOO JEONG		
申请(专利权)人(译)	KIM, 宋勋 廉, JOO SEOK 刘某KYU WAN CHOI, 郑某SOO		
当前申请(专利权)人(译)	三星DISPLAY CO., LTD.		
[标]发明人	KIM SUNG HOON YEOM JOO SEOK RYU KYU WAN CHOI JEONG SOO		
发明人	KIM, SUNG-HOON YEOM, JOO SEOK RYU, KYU WAN CHOI, JEONG SOO		
IPC分类号	G02F1/1343 G02F1/1362		
CPC分类号	G02F1/136227 G02F1/136209 G02F2201/52 G02F2001/136222 G02F2201/40 G02F2001/134372		
审查员(译)	常, CHARLES		
优先权	1020110096523 2011-09-23 KR		
其他公开文献	US20130077008A1		
外部链接	<a href="#">Espacenet</a> <a href="#">USPTO</a>		

摘要(译)

其中公共电压线直接设置在公共电极上或直接设置在公共电极下方的液晶显示器直接接触公共电极，使得公共电压线的信号延迟可以减小并且同时降低液晶的孔径比。可以防止显示。

