



US006636285B2

(12) **United States Patent**  
**Coleman et al.**

(10) **Patent No.:** **US 6,636,285 B2**  
(45) **Date of Patent:** **Oct. 21, 2003**

(54) **REFLECTIVE LIQUID CRYSTAL DISPLAY WITH IMPROVED CONTRAST**

WO WO 96/37805 11/1996  
WO WO 98/32047 7/1998

(75) Inventors: **Zane Arthur Coleman**, Atlanta, GA (US); **George Thomas Valliath**, Buffalo Grove, IL (US); **Jon Lindsay Schindler**, Glenview, IL (US)

**OTHER PUBLICATIONS**

T. John Trout, William J. Gambogi, Kirk W. Steijn and Steven R. Mackara; "15.3: *Volume Holographic Components for Display Applications*"; Society for Information Display 00 Digest; pp. 1-4.

Herwig Kogelnik; "*Coupled Wave Theory for Thick Hologram Gratings*"; The Bell System Technical Journal, vol. 48, No. 9 (Nov. 1969), pp. 2909-2947.

William J. Gambogi, Andrew M. Weber and T. John Trout; "*Advances and Applications of DuPont Holographic Photopolymers*"; Proc. SPIE. vol. 2043, pp. 2-13 (1993).

H. Hiraki, S. Ueki, S. Mitui, Y. Higashigaki, M. Matsuura; "*P-54: A Reflective TFT-LCD Using Twist PDLC Mode with a Single Polarizer*"; Digest of Technical Papers from Society for Information Display Conference; San Jose, Ca; May 1999; pp. 686-689.

(List continued on next page.)

(73) Assignee: **Motorola, Inc.**, Schaumburg, IL (US)

(\* ) Notice: Subject to any disclaimer, the term of this patent is extended or adjusted under 35 U.S.C. 154(b) by 7 days.

(21) Appl. No.: **10/002,511**

(22) Filed: **Nov. 1, 2001**

(65) **Prior Publication Data**

US 2003/0081154 A1 May 1, 2003

(51) **Int. Cl.**<sup>7</sup> ..... **G02F 1/1335**

(52) **U.S. Cl.** ..... **349/112**

(58) **Field of Search** ..... 349/112, 64, 113

(56) **References Cited**

**U.S. PATENT DOCUMENTS**

3,837,729	A	9/1974	Harsch	
4,298,249	A	11/1981	Gloor et al.	
5,046,827	A	9/1991	Frost et al.	
5,329,386	A	7/1994	Birecki et al.	
5,629,784	A	5/1997	Abileah et al.	
5,659,408	A	8/1997	Wenyon	
5,663,816	A	9/1997	Chen et al.	
5,721,630	A *	2/1998	Horner et al.	359/15
5,731,858	A *	3/1998	Hisatake et al.	349/112
5,796,455	A *	8/1998	Mizobata et al.	349/112
5,847,860	A	12/1998	Hougham et al.	
6,075,579	A *	6/2000	Ueda et al.	349/64
6,166,787	A *	12/2000	Akins et al.	349/57
6,291,146	B1 *	9/2001	Chang et al.	430/394

**FOREIGN PATENT DOCUMENTS**

GB 2306229 A 4/1997

*Primary Examiner*—Kenneth Parker

(74) *Attorney, Agent, or Firm*—Daniel K. Nichols

(57) **ABSTRACT**

A display (200) includes a slanted fringe volume hologram (206) or other optical element that steers light that passes into and out of the display (200) so as to provide angular separation between unmodulated scattered light and modulated reflected light. As a result of the angular separation the effective contrast of the display (200) is improved. By placing the slanted fringe volume hologram (206) below a front polarizer of the display a further reduction in the amount of unmodulated scatter light is achieved. The slanted fringe volume hologram is preferably a hologram of a diffusive object (328), and consequently exhibits a degree of light diffusion that results in a viewing zone of an appreciable angular extent.

**18 Claims, 3 Drawing Sheets**

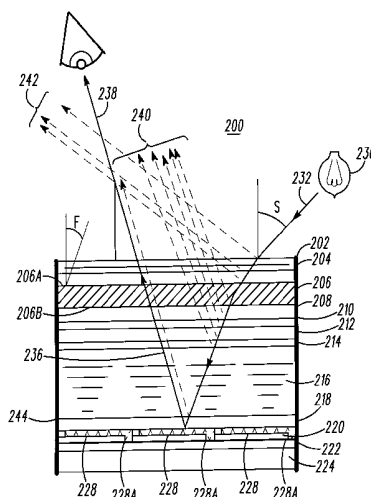

OTHER PUBLICATIONS

G.T. Valliath, Z.A. Coleman, J.L. Schindler, R. Polak, R.B. Akins, K.W. Jelley; “*Design of Hologram for Brightness Enhancement in Color LCDs*”; Digest of technical Papers from Society for Information Display Conference; San Jose, CA; May 1998, p. 1139–1143.

Gregory P. Crawford; “*Liquid Crystal Displays: The Flatter the Better*”; IEEE Potentials; 1998; pp. 38–42.

DuPont Holographics; “*Holographic Front-Diffuser Application Note*”; Rev. Aug. 31, 2000; pp. 1–3.

Sanyo Product Description; “*Reflective LCD Technology Advances from Sanyo*”.

Web Based LCD Comparison Chart located at: <http://www.trl.ibm.com/projects/reflcd/refexpe.htm>.

\* cited by examiner

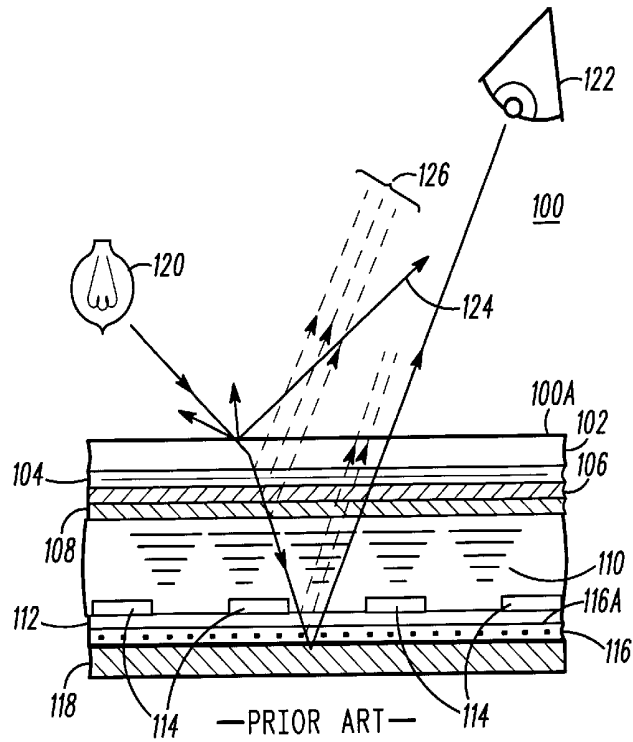

FIG. 1

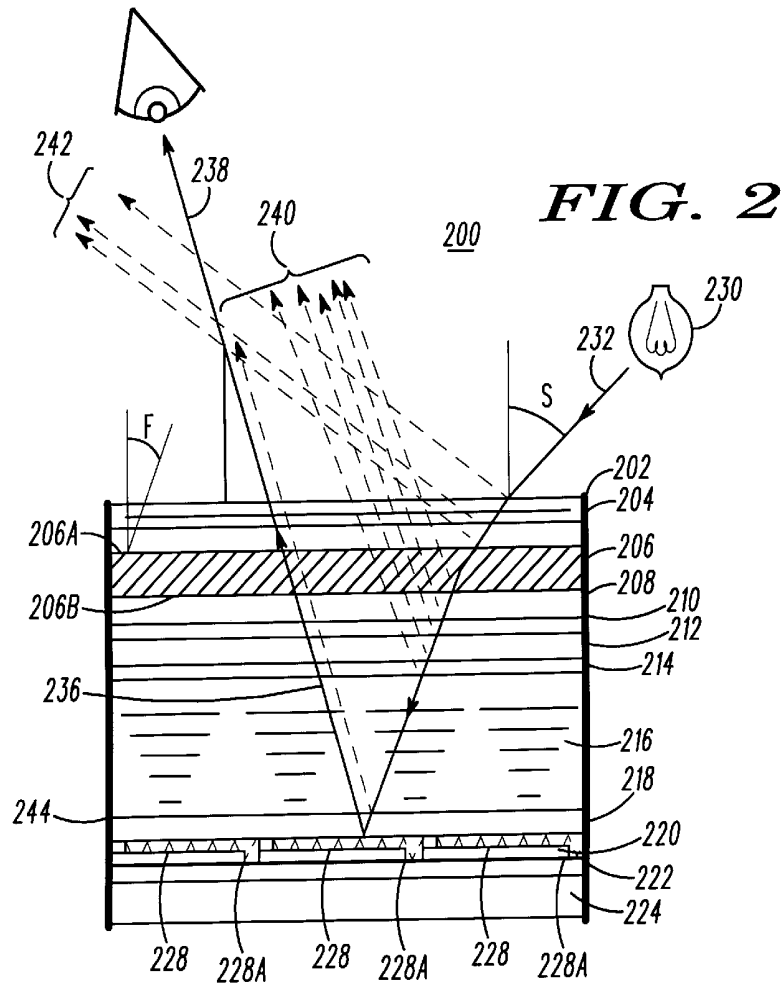

FIG. 2

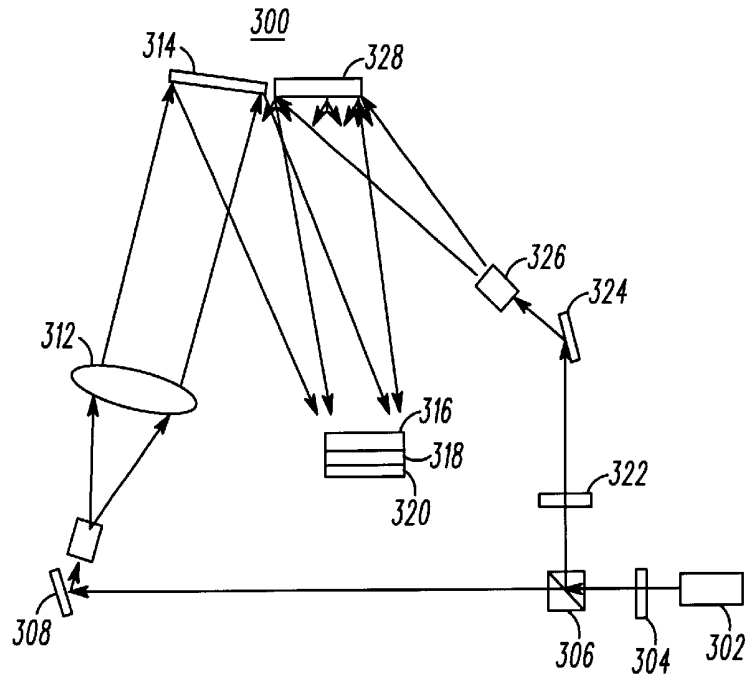

FIG. 3

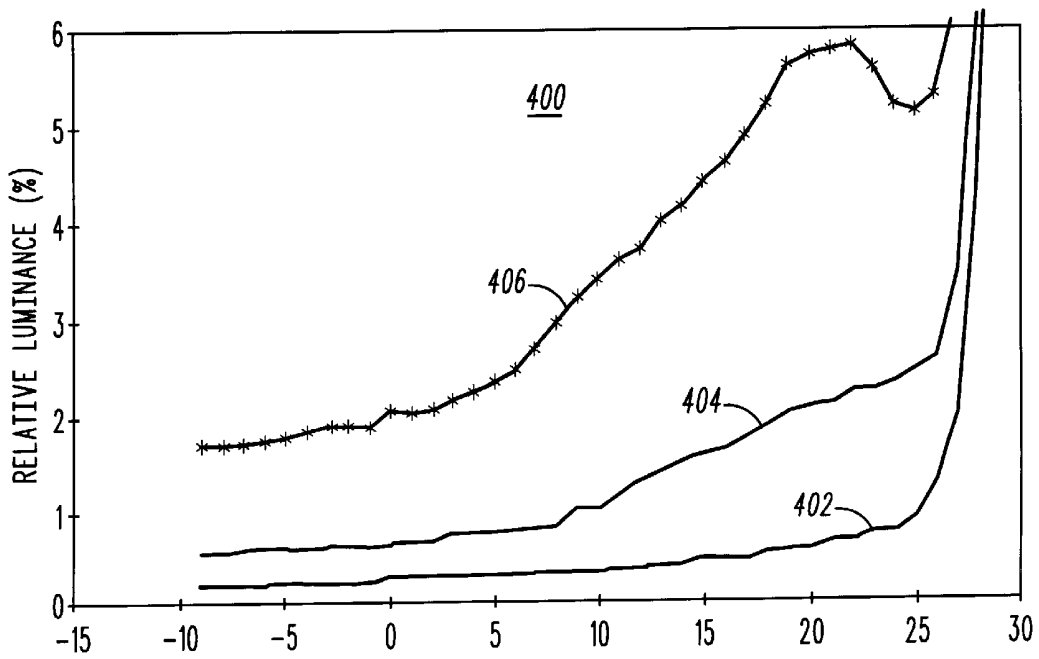
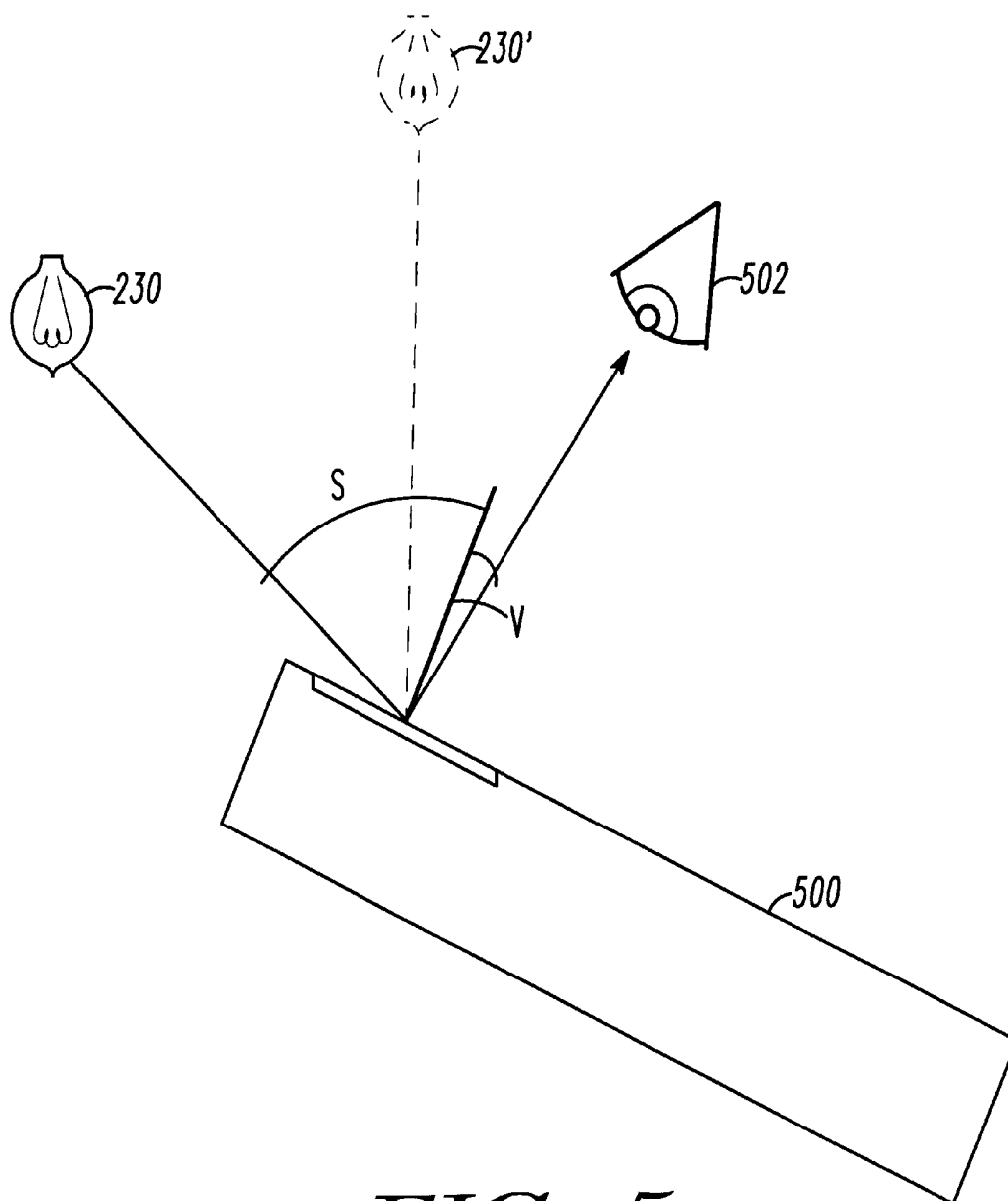

FIG. 4



**FIG. 5**

## REFLECTIVE LIQUID CRYSTAL DISPLAY WITH IMPROVED CONTRAST

### FIELD OF THE INVENTION

This invention pertains to liquid crystal displays. More particularly this invention pertains to reflective liquid crystal displays.

### BACKGROUND OF THE INVENTION

Liquid crystal displays (LCD) are used in a variety of electronic devices including pagers, and portable digital assistants. Liquid crystal displays offer the advantages of compactness and low power consumption. Liquid crystal displays include an array of separately controllable display areas termed pixels. Each pixel includes electrodes for establishing a localized electric field that locally effects the state of a liquid crystal material. Propagation of light through the each pixel is in turn affected by the state of the liquid crystal material. Spatial modulation of light is achieved by applying different signals to the electrodes associated with different pixels of a display.

One variety of liquid crystal display is the reflective type. Reflective liquid crystal displays spatially modulate light by selectively (e.g., according to an image pattern) reflecting incident ambient light. The brightness of reflective liquid crystal displays is determined by the brightness of the ambient light, and the reflectivity of the display. In addition to brightness another important measure of performance of liquid crystal displays that is related to brightness is contrast. Contrast is the difference between the brightness of a display area (pixel) that is set to a non-reflecting (dark) state, and the brightness of a display area that is set to a reflecting (bright) state. Contrast of a display is diminished by reflections off of surfaces, and interfaces within the display that are located in front of the liquid crystal material. Such reflections are not spatially modulated and therefore increase the brightness of the entire display area including areas that are meant to be turned off. The latter problem is somewhat aggravated by the fact users tend to orient reflective liquid display at an angle close to the angle at which specular reflection of light from an ambient light source (e.g., fluorescent lamp, the sun) reaches their eyes. Unfortunately, orienting a liquid crystal display at an angle which leads to specular reflection of source light into a user's eyes leads increases the intensity of both spatially modulated, and unmodulated light reaching the user's eyes. In order to achieve acceptable contrast a user must precisely adjust the orientation of the display to an angle at which the spatially modulated light predominates over unmodulated light. The range of solid angle of orientation in which the display can be viewed (termed the viewing zone) may be quite limited, such that the user must be careful in maintaining the orientation of the display.

Published PCT application WO 98/32047 that is assigned to the assignee of the present invention teaches a liquid crystal display that includes a transmissive holographic element that deflects light so as to provide angular separation between light that has passed through a liquid crystal material layer (modulated light) and light that is reflected by the holographic without passing through the liquid crystal material layer (unmodulated light). The angular separation between the modulated and unmodulated light effectively increases the contrast of the display by allowing a user to view the modulated light without viewing the unmodulated light. A certain amount of reflection of spatially unmodulated light occurs at layer interfaces between the transmis-

sive holographic element and the liquid crystal material. Such unmodulated reflection tends to decrease the contrast of the display

What is needed is a liquid crystal display that increases the intensity of spatially modulated reflected light, relative to the amount of unmodulated reflected light.

What is needed is a display that provides increased contrast.

What is needed is a needed is a system that provides a viewing zone of substantial angular extent.

### BRIEF DESCRIPTION OF THE DRAWINGS

The features of the invention believed to be novel are set forth in the claims. The invention itself, however, may be best understood by reference to the following detailed description of certain exemplary embodiments of the invention, taken in conjunction with the accompanying drawings in which:

FIG. 1 is a schematic sectional elevation view of a prior art liquid crystal display that includes a transmission holographic optical element.

FIG. 2 is a sectional elevation view of a liquid crystal display including a slanted fringe volume hologram according to a preferred embodiment of the invention.

FIG. 3 is a schematic of an apparatus for producing the slanted fringe volume hologram according to the preferred embodiment of the invention.

FIG. 4 is a graph of reflectivity measurements that demonstrate the effect on overall reflectance of switching the order of a polarizer and the slanted fringe volume hologram in a multilayer structure.

FIG. 5 is a schematic illustration of a handheld device that uses the liquid crystal display shown in FIG. 2.

### DETAILED DESCRIPTION OF THE PREFERRED EMBODIMENT

While this invention is susceptible of embodiment in many different forms, there are shown in the drawings and will herein be described in detail specific embodiments, with the understanding that the present disclosure is to be considered as an example of the principles of the invention and not intended to limit the invention to the specific embodiments shown and described. Further, the terms and words used herein are not to be considered limiting, but rather merely descriptive. In the description below, like reference numbers are used to describe the same, similar, or corresponding parts in the several views of the drawings.

FIG. 1 is a schematic sectional elevation view of a prior art liquid crystal display **100** that includes a transmission holographic optical element **102** as taught in published PCT application WO 98/32047. The transmission holographic element **102** is located at a front viewing surface **100A** of the display **100** overlying a first polarizer **104**. A front liquid crystal containment wall **106** is located beneath the first polarizer **104**. A transparent counter electrode **108** is deposited on the bottom of the front liquid crystal containment wall **106**. A back liquid crystal containment wall **112** is located below the front liquid crystal containment wall **106**. A twisted nematic liquid crystal material **110** is located between the front liquid crystal containment wall **106** and back liquid crystal containment wall **112**. The front **106** and back **112** liquid crystal containment walls are transparent. A plurality of drive electrodes **114** are supported on the back liquid crystal containment wall **112**. The drive electrodes **114** are used to in conjunction with the transparent counter

electrode **108** to establish localized electric fields in the liquid crystal material **110** that locally affect the alignment of the liquid crystal **110** in order to spatially modulate the reflection of incident light. A second polarizer **116** is located below the back liquid crystal containment wall **112**. A reflector **118** is located below the second polarizer **116**. Alignment layer coatings (not shown) are applied to the transparent counter electrode **108**, and back liquid crystal containment wall **112** in order to urge the liquid crystal material **110** into a twisted nematic state.

In operation light that emanates from a source **120** is incident on the display **100**, is polarized by the first polarizer **104** and passes into the liquid crystal material **110**. In the reflective state, owing to the twisted nematic state, the polarization of the light is rotated as it passes through the liquid crystal material **110**. The light reaches the second polarizer **116** passes through it to the reflector **118**, is reflected by the reflector **118** and pass back through the display **100** to a user's eye **122**. In passing back through the liquid crystal material, the polarization of the light is again rotated so that it is able to pass through the first polarizer **104**. In order to set a pixel of the display **100** to a dark state, a voltage is applied to an electrode **114** for the pixel in order to establish and electric field in the liquid crystal proximate the particular electrode **114**. The electric field changes the state of the liquid crystal material **110** proximate the particular electrode from the twisted nematic state so that that the liquid crystal material in the vicinity of the particular electrode no longer serves to rotate the polarization of light passing through it. Since the polarization of the light is not rotated it is no longer able to pass through the second polarizer **116** to the reflector **118**.

Light that is modulated by the display **100** passes through the transmission holographic element **100** twice. The transmission holographic element deflects light, so that light that emerges from the display **100** after being spatially modulated propagates in a direction that is different from a main direction **124** that characterizes light scattered off the transmission holographic element **102**. Because of the difference in direction, the amount of unmodulated light reaching a users eye will be reduced, and the contrast of the display will be effectively increased. Note however that a portion of light **126** that is reflected by layer interfaces that are located between the transmission holographic element **102**, and front surface **116A** of the rear polarizer **116**, propagates in the same direction as modulated light. The light reflected by the interfaces **126** is unmodulated and therefore tends to reduce the contrast of the display **100**.

Liquid crystal displays are used in handheld devices such as text messaging pagers, cell phones, and personal digital assistants. When viewing the liquid crystal display of handheld devices, users tend to hold the handheld device so that a their own line of sight to the display makes an angle of up to about 15 degrees from perpendicular to the display surface. (As is conventional in the field of optics, angles of incidence at surfaces as discussed in this application, are measured from perpendiculars to the respective surfaces.) Furthermore handheld devices are commonly held such that a line between the display and the dominant ambient light source in the vicinity (e.g., a particular fluorescent light fixture, the sun) is between about 19 and 49 degrees from the perpendicular to the display. The average of the latter two angles, 34 degrees, is taken as representative of the typical angle at which the ambient light is incident on displays of handheld devices.

What is needed is a display that can accept illumination incident at an angle of between about 19 and 49 degrees, and

output a substantial fraction of modulated light at an angle that is within 15 degrees of the perpendicular to the display surface, and reduce the amount of unmodulated light reflected at an angle within 15 degrees of the perpendicular to the display surface.

FIG. **2** is a sectional elevation view of a liquid crystal display **200** including a slanted fringe volume hologram **206** according to a preferred embodiment of the invention. The liquid crystal display **200** comprises a sequence of layers that will be described starting from the top of FIG. **2**. The top most layer is a polarizer **202**. A compensation layer **204** is located below the polarizer **202**. The compensation layer **204** introduces a fixed polarization rotation. A slanted fringe volume hologram **206** is located below the compensation layer **204**. The function of the slanted fringe volume hologram **206** is described below in more detail.

An upper liquid crystal containment wall **208** is located below the slanted fringe volume hologram **206**. The slanted fringe volume hologram **206** includes a top side **206A** and a bottom side **206B**. A color filter array **210** is located below the upper liquid crystal containment wall **208**. The color filter array **210** comprises an array of color filters.

A transparent counter electrode coating **212** is located below the color filter array and black mask layer **210**. An upper liquid crystal alignment layer **214** is located below the transparent counter electrode coating **212**. A liquid crystal material layer **216** is located below and in contact with the upper liquid crystal alignment layer **214**. A lower liquid crystal alignment layer **218** (having an alignment axis that differs from that of the upper liquid crystal alignment layer **214**) is located below and in contact with the liquid crystal material layer **216**.

A plurality of reflective pixel electrodes **228** are located below the lower liquid crystal alignment layer **218**. The reflective pixel electrodes **228** are preferably specularly reflective. According to a first alternative embodiment of the invention, the reflective pixel electrodes are diffusely reflective. An insulator layer **220** is located below the reflective pixel electrodes **228**. A thin film transistor (TFT) and interconnect grid layer **222** is located below the insulator layer **220**. A plurality of vias **228A** extend from the reflective pixel electrodes **228** through the insulator layer **220** to the TFT and interconnect layer **222**. A lower liquid crystal containment wall **224** is located below the TFT and interconnect layer **222**. The upper **214** and lower **218** liquid crystal alignment layers serve to urge the liquid crystal material layer **216** to assume a twisted nematic state. The twisted nematic state persists in the absence of an applied electric field. In the absence of an applied electric field, the polarization of light is rotated by the liquid crystal material layer **216** by about ninety degrees as the light passes from the polarizer **202**, to the reflective pixel electrodes **228** and back to the polarizer **202**. After being rotated by 90 degrees light is unable to pass through the polarizer. Thus, in the absence of an applied electric field, pixels of the display **200** are in the off-state, meaning that they reflect very little light. In order to switch a particular pixel on a voltage is applied to one of the plurality of pixel electrodes **228** that is associated with that pixel in order to establish a localized electric field that disturbs the twisted nematic state of the liquid crystal material layer **216** in the pixel region. When the twisted nematic state of the liquid crystal material layer **216** is disturbed, the rotation of the polarization of light by the liquid crystal material layer **216** is reduced so that the amount of light that is able to pass the polarizer **202** is commensurately increased. Thus by modulating the polarization of light the intensity of reflect light is modulated. The

liquid crystal material layer **216** serves as a polarization modulation element, however the ultimate purpose is to spatially intensity modulate light to form a displayed image.

Light passes into the display **200** from an ambient light source **230**. The light is incident on the display **200** (i.e., on the polarizer **202**) at an angle of incidence  $S$  (measured with respect to a perpendicular to the display surface). As discussed above  $34$  degrees is considered a typical angle of incidence  $S$  of source light on displays used in handheld devices. A first pencil of light from the source **230** that is incident on the display **200** is represented by ray **232**. The first pencil of light is refracted somewhat at the surface of the upper polarizer **202** due to the index of refraction change, and again at the interface of the polarizer **202** and the compensation layer **204**. An average fringe slant angle  $F$  that characterizes the slant of fringes of the slanted fringe volume hologram **206** is preferably chosen so that a substantial portion of light that is incident from the source **230** at angles within an expected range, preferably between  $19$  and  $49$  degrees, is deflected upon passing through the slanted fringe volume hologram **206**. The first pencil of light is incident on the top side **206A** of slanted fringe volume hologram **206**. A second pencil of light that is formed by deflection of a substantial portion of light in the first pencil of light is represented by ray **234**, and is characterized by a second angle. The fringe slant angle is chosen so that the second angle is non-zero (relative to normal to the display). A small portion of light from the first pencil of light may be diffracted into other diffraction orders outside of the second pencil of light. The second pencil of light emanates from the bottom side **206B** of the slanted fringe volume hologram **206**. Light in the second pencil of light is preferably more diffuse than light in the first pencil of light. The diffusion of light on passing through the slanted fringe volume hologram **206** is due to a degree of randomness in the pattern of fringes in the slanted fringe volume hologram **206**. In the case of the first alternative embodiment of the invention mentioned above the slanted fringe volume hologram need not be diffusive. The degree of randomness is a consequence of the way in which the slanted fringe volume hologram **206** is manufactured. A preferred apparatus and method for manufacturing the slanted fringe volume hologram **206** is described below with reference to FIG. 3. In the pixel on state, the deflected light will pass through the layers (described above) of the display **200** to the reflective pixel electrodes **228**. The deflected light will be reflected by the one of the reflective pixel electrodes **228** forming a third pencil of light represented by ray **236** that will impinge the bottom side **206B** of the slanted fringe volume hologram **206**. The angles characterizing the second and third pencils of light have the same magnitude but opposite signs. A substantial portion of the light in the third pencil of light will pass through the slanted fringe volume hologram **206** forming a fourth pencil of light represented by ray **238** that propagates from the top side **206A** of the slanted fringe volume grating **206**. In the preferred embodiment, the general direction characterizing the fourth pencil of light is substantially undeflected by the slanted fringe volume hologram **206** from the general direction characterizing the third pencil of light. Although not wishing to be bound by any particular theory of operation it is believed that the slanted fringe volume hologram **206** functions as a Bragg volume grating, and that the lack of deflection of the fourth pencil is due to the large angle between the third pencil of light and angles that satisfy Bragg's Law. The fourth pencil of light exits the display at an average view angle  $V$  that is different in both magnitude and direction (from normal) from the

angle of source light incidence  $S$ . The fourth pencil of light includes light that has been modulated by the display **200**. A small amount of light from the third pencil of light may be diffracted by the slanted fringe volume hologram **206** into other diffraction orders characterized by different angles of propagation. By diffusing light the slanted fringe volume hologram **206** serves to increase the angular extent of the viewing zone of the display **200**.

A first quantity of scattered light indicated by rays **240** is scattered by the interfaces located between the slanted fringe volume hologram and the front surface **224A** of the rear polarizer **224**. The first quantity of scattered light exits the display **200** at the view angle  $V$ . The first quantity of scattered light is not modulated in intensity, and results in a small but undesirable decrease in the contrast of the display **200**.

A second quantity of scattered light indicated by rays **242** is scattered from the surface of the upper polarizer **202** and from the interfaces located between the upper polarizer **202** and the top surface **206A** of the slanted fringe volume hologram **206**. The second quantity of scattered light exits the display **200** at an angle that is different from the view angle. By placing the slanted fringe volume hologram **206** below the polarizer **202** and the compensation layer **204**, a liquid crystal display **200** is obtained in which light scattered at the surfaces of the polarizer **202** and the compensation layer **204** are scattered away from the angle of view  $V$ . Light scattered away from the field of view does not adversely effect the contrast of the display **200**. An additional advantage that accrues from placing the hologram **206** below the polarizer **202** is that any light that is scattered in the viewing direction  $V$  by imperfections of the hologram **206** (e.g., localized imperfections or periodic imperfections) will be attenuated in passing through the polarizer **202**.

According to a second alternative embodiment of the invention, the slanted fringe volume hologram **206** is shifted to a position below that shown in FIG. 2 closer to the liquid crystal material layer **216**.

In order to accommodate the typical angles of incidence of source light, and in order to achieve a viewing zone that is centered within  $15$  degrees of perpendicular to the display **200**, the average fringe slant angle  $F$  is preferably between about  $6$  and about  $22$  degrees from normal to the display **200**. Preferably, aforementioned average fringe slant angle extends from normal to the display **200** away from a proximal side **244** of the display **200** which in use faces a user. Note that the view angle  $V$  extends in an opposite direction from normal to the display compared to the average fringe slant angle  $F$ . The average index of refraction of the slanted fringe volume hologram **206** is preferably between about  $1.4$  and  $1.6$ .

FIG. 3 is a schematic of an apparatus **300** for producing the slanted fringe volume hologram **206** according to the preferred embodiment of the invention. The slanted fringe volume hologram **206**, is preferably an off-axis hologram of a diffusive object. The apparatus comprises a laser **302** source. The laser **302** preferably outputs light in the green region of the visible spectrum. Output of the laser **302** is coupled through a first half-wave plate **304** to a polarizing beam splitter **306**. The polarizing beam splitter **306** splits the received beam into first and second sub-beams. The first sub-beam is reflected by a first turning mirror **308** through a first lens-pinhole spatial filter **310**. The first lens-pinhole spatial filter **310** filters undesirable modes from the first sub-beam. The first sub-beam diverges from the first lens-pinhole spatial filter **310** and is coupled through a collimat-

ing lens **312**, to a second turning mirror **314**. The second turning mirror **314** reflects the first sub-beam toward a glass superstrate **316**, that overlies a holographic recording material blank **318**. A black absorber **320** underlies the holographic recording material blank **318**.

The holographic recording material blank **318** preferably comprises a photopolymer sheet that is suitable for making volume holograms. One type of photopolymer that is suitable for fabricating the slanted fringe volume hologram **206** is sold under the trade name "HRF-600" by Dupont Corporation of Wilmington, Del. The holographic recording material blank **318**, and the slanted fringe volume hologram **206** produced from it are preferably less than about 30 microns thick. Too thick a slanted fringe volume hologram **206** would cause excessive scattering.

The second sub-beam produced by the polarizing beam splitter **306** is coupled through a second half wave plate **322**, and in turn reflected by a third turning mirror **324** through a second lens-pinhole spatial filter **326**. The second lens-pinhole spatial filter **326** filters undesirable components from the second sub-beam and diverges the second sub-beam. After passing through the second lens-pinhole spatial filter **326** the second sub-beam illuminates a diffusive object **328**. The diffusive object preferably diffuses light from the second sub-beam over the entire range of solid angle subtended by the holographic recording material blank **318**. As shown the diffusive object is reflective. Barium Sulphate, and Magnesium are two examples of materials that are known for their diffuse reflectance properties. According to a third alternative embodiment of the invention the second sub-beam is coupled through a transmissive diffuser such as a ground glass plate. The first sub-beam serves as a reference beam, and the second sub-beam serves as an object beam for forming the slanted fringe volume hologram **206**.

The average of the angles that characterize the first sub-beam and the diffused second sub-beam as measured relative to the holographic recording material blank **318** is about the average fringe angle  $F$ . There is some variance in the angle of arrival of the light due to finite extent of the diffusive object **328**, and the holographic recording material blank **318**, and due to the diffusion of the second sub-beam. The first sub-beam is preferably incident on the material blank **318** at an angle between about 19 and 49 degrees, whereas the second sub-beam is preferably incident on the material blank **318** at an angle between about 0 and 19 degrees. The foregoing angles are chosen based on the typical source angle  $S$  and view angle  $V$ , in order to achieve high contrast spatial light modulation.

The first sub-beam serves as a reference beam and the second sub-beam serves as an object beam. The first sub-beam and the diffused second sub-beam interfere at the holographic recording material blank **318** thereby exposing the slanted fringe pattern. Exposure leads to localized changes in index of refraction of the blank **318**. Material dependent post exposure development processing steps may be used to fix or enhance the exposed pattern before the slanted fringe volume hologram **206** is ready for use. Post exposure development processes are specified by the manufacturers of the recording material blanks. For example for the HRF-600 photopolymer mentioned above, heating at 120 C for two hours is effective to increase the degree of refractive index modulation produced during exposure.

FIG. 4 is a graph **400** of reflectivity measurements that demonstrate the effect on overall reflectance of switching the order of a polarizer and the slanted fringe volume hologram **206** in a multilayer structure.

The ordinate of the graph **400** is luminance of reflected light on a relative scale. The abscissa of the graph is the angle of a detector used to measure reflectance with respect to the surface being measured (measured from perpendicular). The domain of the graph extends from -15 to 30 degrees. In the measurements each surface or multilayer structure being tested was illuminated by collimated light incident at -34 degrees. The lowest plot **402** shows the baseline reflectivity versus detector angle for a black acrylic that was used as an underlying absorber in two other tests. The middle plot **404** shows the reflectivity versus angle for a first multilayer stack consisting of a polarizer on top of the slanted fringe volume hologram **206** on top of the black acrylic. The upper plot **406** shows the reflectivity versus angle for a second multilayer stack in which the positions of the slanted fringe volume hologram **206** and the polarizer are reversed. Thus it is appreciated from the graph that by placing the slanted fringe volume hologram **206** below the upper polarizer **202**, unwanted reflectance over a broad range of angles (including the viewing zone) is reduced in relative intensity. The reflectance measurements shown in FIG. 4 correspond to unmodulated reflectance of a liquid crystal display. Consequently, by locating the slanted fringe volume hologram **206** below the upper polarizer, a display that reflects less unmodulated light and offers increased contrast is obtained.

According to a fourth alternative embodiment of the invention a surface relief diffraction grating is used in lieu of the slanted fringe volume hologram **206**. The profile of the surface relief grating may be filled with a material that has an index of refraction that differs from an index of refraction of the surface relief grating.

FIG. 5 is a schematic illustration of a handheld device **500** that uses the liquid crystal display **200** of FIG. 2.

The handheld device **500** is positioned so that the line sight between a viewer's eye **502** and the display **200** is at a view angle  $V$  that is preferably less than 15 degrees in magnitude. Light from the source **230** illuminates the display at an angle  $S$  which is typically between 19 and 49 degrees. An alternate position of the source indicated by reference numeral **230'** is shown. The alternate position leads to a smaller source illumination angle within the aforementioned range. The slanted fringe volume hologram **206** establishes a direction of modulated light into a viewing zone that includes the angle of view  $V$ , and directs at least a substantial portion of unmodulated scattered light out of the viewing zone.

While the preferred and other embodiments of the invention have been illustrated and described, it will be clear that the invention is not so limited. Numerous modifications, changes, variations, substitutions, and equivalents will occur to those of ordinary skill in the art without departing from the spirit and scope of the present invention as defined by the following claims.

What is claimed is:

1. A display comprising:

a light modulating element;

a polarizer located on a first side of the light modulating element;

a reflective element located on a second side of the light modulating element; and

an optical element that is:

located between the light modulating element and the polarizer;

includes a first side facing the polarizer, and a second side facing the light modulating element; and

is adopted to:  
 receive a first pencil of light characterized by a first angle at the first side, and in response to receiving the first pencil of light, output a second pencil of light that is characterized by a second angle and includes a substantial portion of light from the first pencil of light at the second side;  
 receive a third pencil of light that is characterized by a third angle at the second side, and in response to receiving the third pencil of light output a fourth pencil of light that is characterized by a fourth angle and includes a substantial portion of light from the third pencil of light at the first side, wherein the first angle differs in magnitude from the fourth angle;  
 the optical element comprising a slanted fringe volume hologram that is characterized by a fringe slant angle.

2. The display according to claim 1 wherein: the reflective element is specular and is adapted to form the third pencil of light by reflecting the second pencil of light.

3. The display according to claim 1 wherein the fringe slant angle is between about 6 and about 22 degrees from normal to the display.

4. The display according to claim 3 wherein the slanted fringe volume hologram is characterized by an average index of refraction of between about 1.4 and about 1.6.

5. The display according to claim 1 wherein the light modulating element comprises a light polarization modulating element.

6. The display according to claim 5 wherein the light polarization modulating element comprises a liquid crystal material.

7. A liquid crystal display comprising:  
 a layer of liquid crystal material;  
 a polarizer located on a first side of the layer of liquid crystal material; and  
 a slanted fringe volume hologram located between the layer of liquid crystal material and the polarizer.

8. The liquid crystal display according to claim 7 wherein the slanted fringe volume hologram is an off-axis hologram of a diffusive object.

9. The liquid crystal display according to claim 7 wherein: the slanted fringe volume hologram is manufactured by making a hologram of a diffuser in a photosensitive material.

10. The liquid crystal display according to claim 9 wherein:  
 the slanted fringe volume hologram is manufactured by impinging a reference beam on the photosensitive material at an angle between about 19 and about 49 degrees; and

impinging an object beam on the photosensitive material at an angle between about zero and about 19 degrees.

11. The liquid crystal display according to claim 7 wherein:  
 the slanted fringe volume hologram is characterized by:  
 a average fringe slant angle of between about 6 and about 22 degrees; and  
 an average index of refraction of between about 1.4 and about 1.6.

12. The liquid crystal display according to claim 11 wherein:  
 the slanted fringe volume hologram is manufactured by creating a hologram of a diffuser in a photosensitive material.

13. The liquid crystal according to claim 12 wherein: the slanted fringe volume hologram is less than about 30 microns thick.

14. The liquid crystal display according to claim 13 wherein:  
 the photosensitive material is a photopolymer.

15. The liquid crystal display according to claim 13 further comprising:  
 a first alignment layer characterized by a first alignment axis in contact with a first side of the layer of liquid crystal material layer;  
 a second alignment layer characterized by a second alignment axis that is different from the first alignment axis in contact with a second side of the layer of liquid crystal material layer; and  
 a plurality of reflective electrodes for applying electric fields to the layer of liquid crystal material in localized areas.

16. A handheld device comprising:  
 liquid crystal display including:  
 a layer of liquid crystal material;  
 a polarizer located on a first side of the layer of liquid crystal liquid crystal; and  
 a slanted fringe volume hologram located between the layer of liquid crystal material and the polarizer.

17. The handheld device according to claim 16 wherein: the slanted fringe volume hologram is characterized by:  
 a average fringe slant angle of between about 6 and about 22 degrees; and  
 an average index of refraction of between about 1.4 and about 1.6.

18. The handheld device according to claim 17 wherein the slanted fringe volume hologram is an off-axis hologram of a diffusive object.

\* \* \* \* \*

专利名称(译)	具有改善对比度的反射型液晶显示器		
公开(公告)号	<a href="#">US6636285</a>	公开(公告)日	2003-10-21
申请号	US10/002511	申请日	2001-11-01
[标]申请(专利权)人(译)	COLEMAN ZANE ARTHUR VALLIATH GEORGE THOMAS 辛德勒JON LINDSAY		
申请(专利权)人(译)	COLEMAN ZANE ARTHUR VALLIATH GEORGE THOMAS 辛德勒JON LINDSAY		
当前申请(专利权)人(译)	MOTOROLA , INC.		
[标]发明人	COLEMAN ZANE ARTHUR VALLIATH GEORGE THOMAS SCHINDLER JON LINDSAY		
发明人	COLEMAN, ZANE ARTHUR VALLIATH, GEORGE THOMAS SCHINDLER, JON LINDSAY		
IPC分类号	G02F1/13 G02F1/1335 G02F1/1362 G02F1/133		
CPC分类号	G02B5/0252 G02F1/133504 G02F2203/02 G02F1/1362 G02F1/133553		
代理机构(译)	NICHOLS , DANIEL K.		
审查员(译)	PARKER , KENNETH		
其他公开文献	US20030081154A1		
外部链接	<a href="#">Espacenet</a> <a href="#">USPTO</a>		

摘要(译)

显示器 ( 200 ) 包括倾斜的条纹体积全息图 ( 206 ) 或其他光学元件 , 其控制进出显示器 ( 200 ) 的光 , 以便在未调制的散射光和调制的反射光之间提供角度分离。作为角度分离的结果 , 显示器 ( 200 ) 的有效对比度得到改善。通过将倾斜的条纹体积全息图 ( 206 ) 放置在显示器的前偏振器下方 , 实现了未调制的散射光量的进一步减少。倾斜的条纹体积全息图优选地是漫射物体的全息图 ( 328 ) , 并且因此表现出一定程度的光漫射 , 这导致可观的角度范围的观察区域。

