



US 20080174543A1

(19) **United States**

(12) **Patent Application Publication**
Nagatani

(10) **Pub. No.: US 2008/0174543 A1**

(43) **Pub. Date: Jul. 24, 2008**

(54) **BACK LIGHT UNIT AND LIQUID CRYSTAL DISPLAY APPARATUS**

(30) **Foreign Application Priority Data**

Nov. 27, 2001 (JP) 2001-360962

(76) Inventor: **Shinpei Nagatani, Kawasaki (JP)**

Publication Classification

Correspondence Address:
Patrick G. Burns, Esq.
Greer, Burns & Crain, Ltd.
Suite 2500, 300 S. Wacker Drive
Chicang, IL 60606

(51) **Int. Cl.**
G09G 3/36 (2006.01)

(52) **U.S. Cl.** **345/102**

(57) **ABSTRACT**

A back light unit includes a lamp, a lamp house where the lamp is housed, a diffusion plate provided parallel to a main surface of the lamp house, a display part receiving light irradiated from the lamp and displaying, a frame member that has a structure in which the diffusion plate and the display part can be housed inside of the frame member and that detachably connects to the lamp house, and a shield member connected in a range from the diffusion plate to the frame member so that a space between the diffusion plate and the frame member is shielded.

(21) Appl. No.: **11/899,082**

(22) Filed: **Sep. 4, 2007**

Related U.S. Application Data

(62) Division of application No. 10/100,423, filed on Mar. 18, 2002, now Pat. No. 7,283,118.

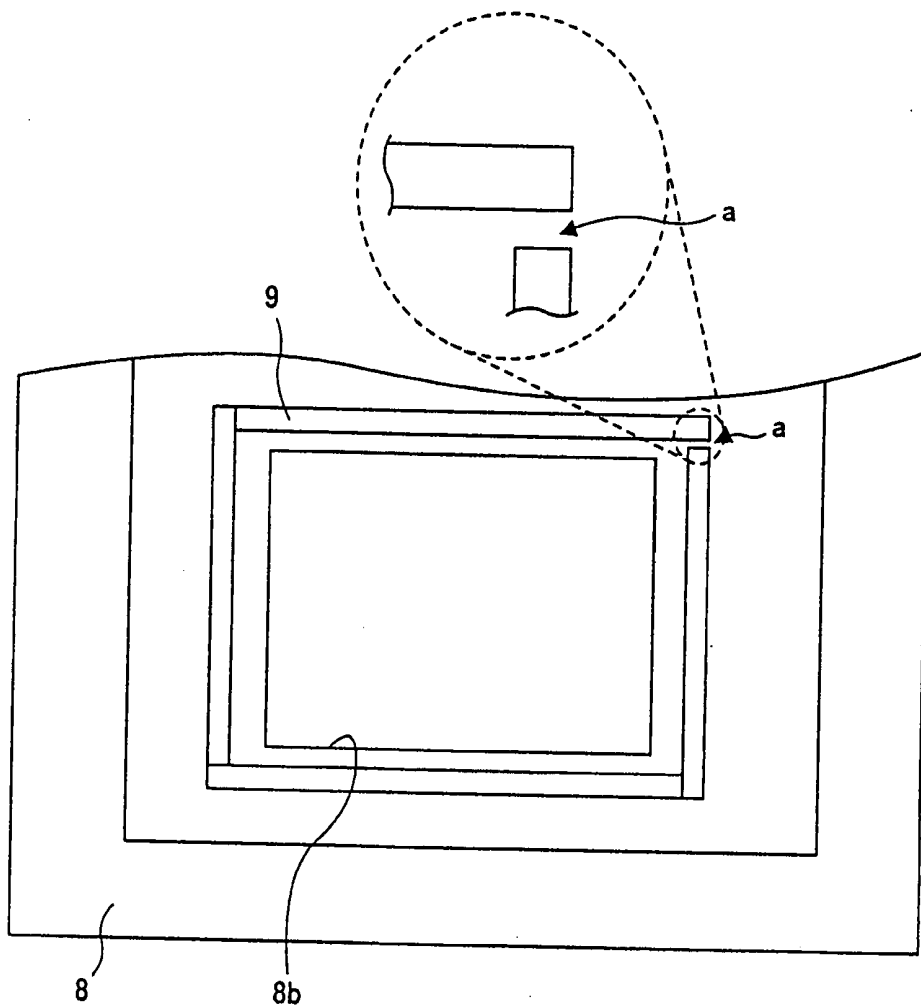

FIG. 1 RELATED ART

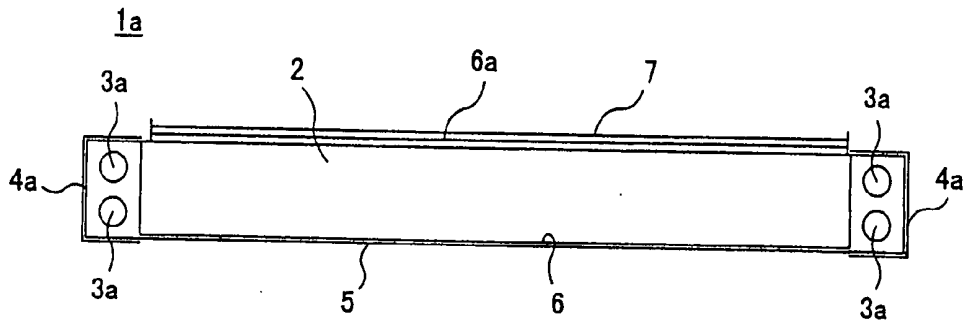

FIG. 2 RELATED ART

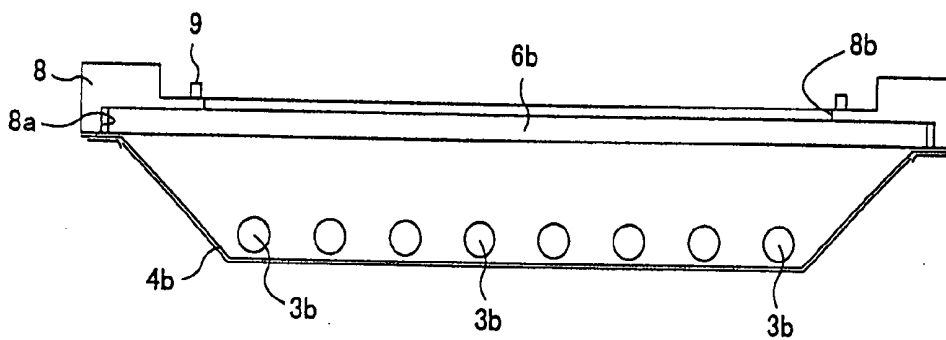

FIG. 3

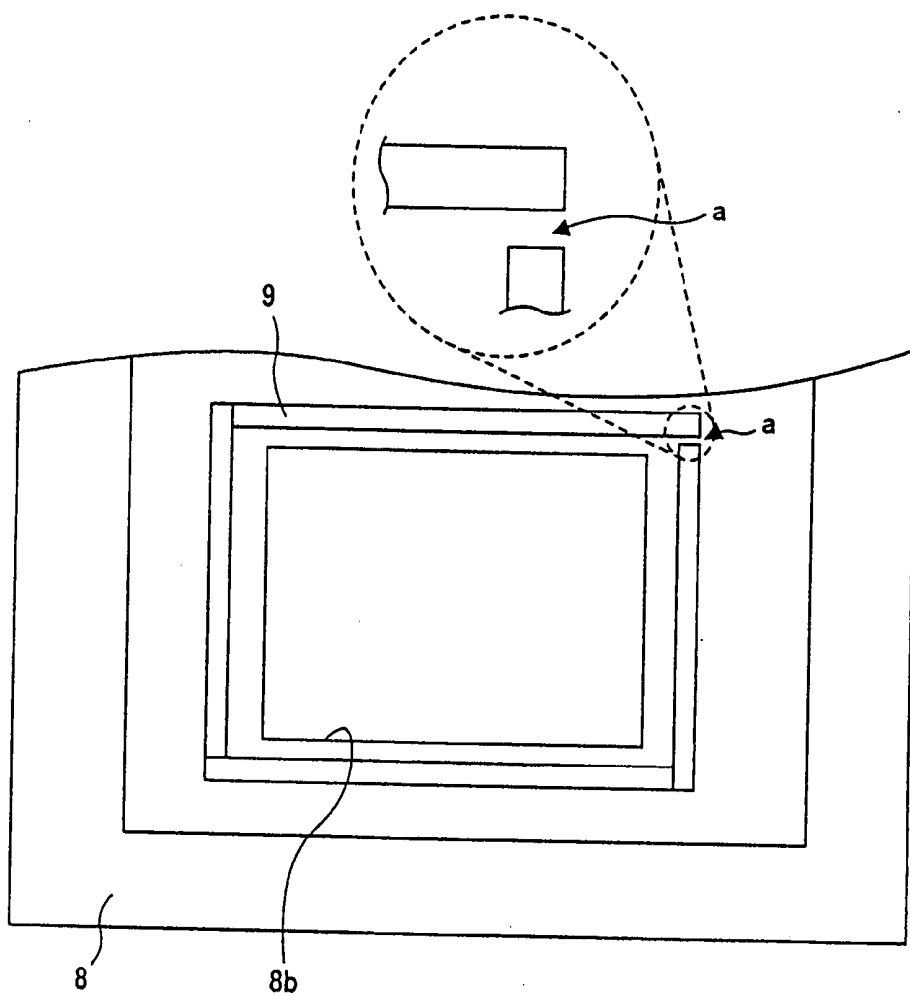

FIG. 4

28

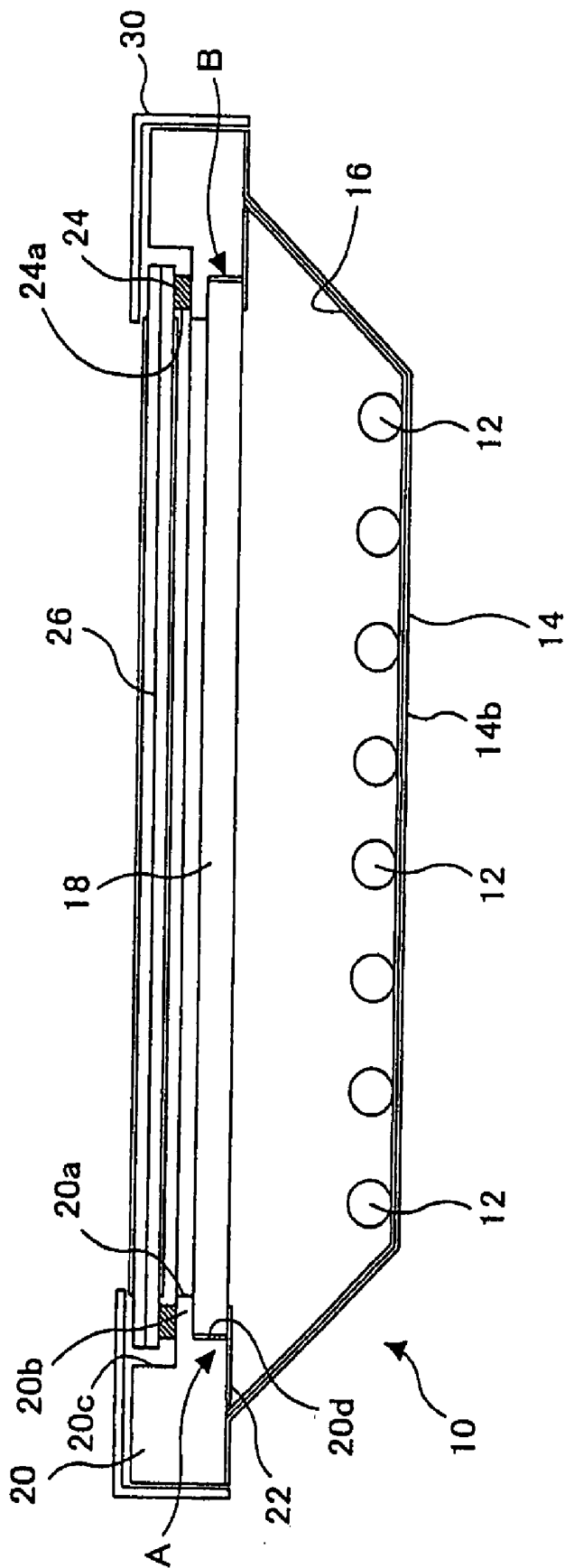

FIG. 5

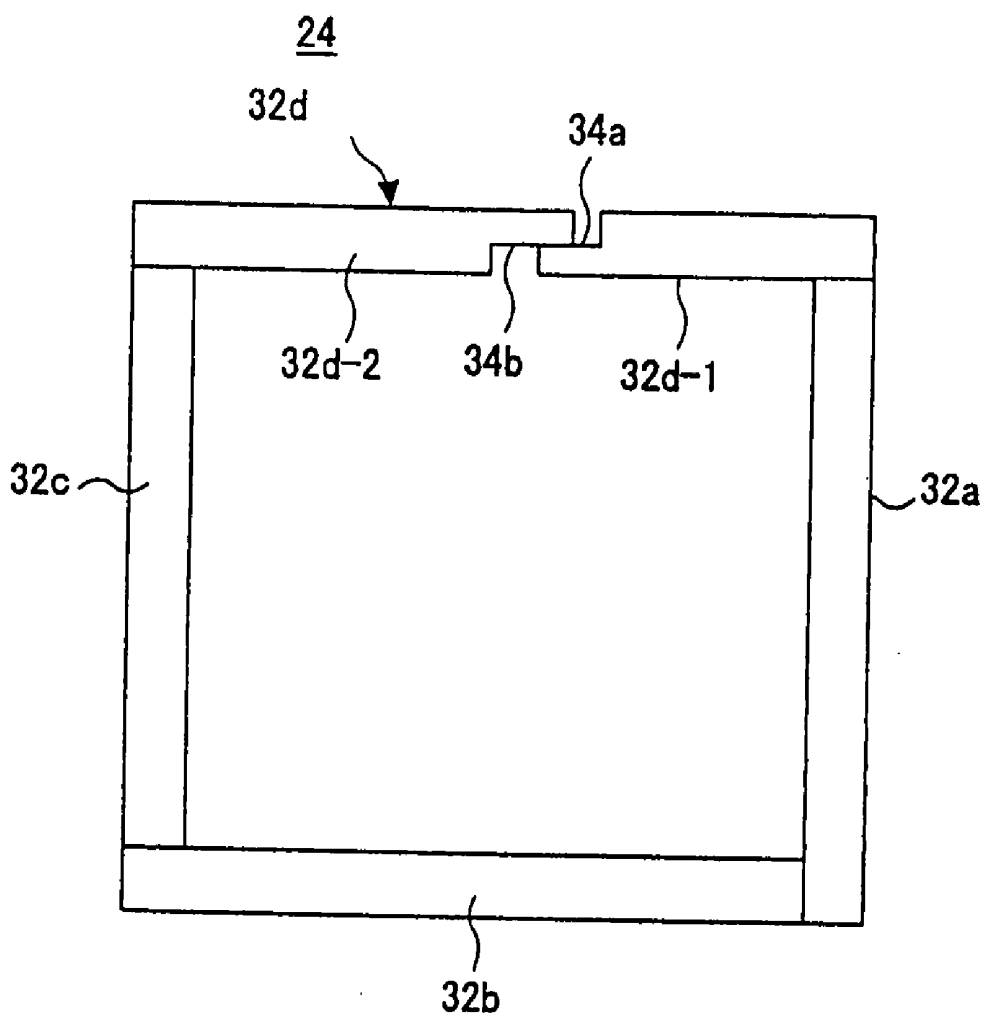

FIG. 6

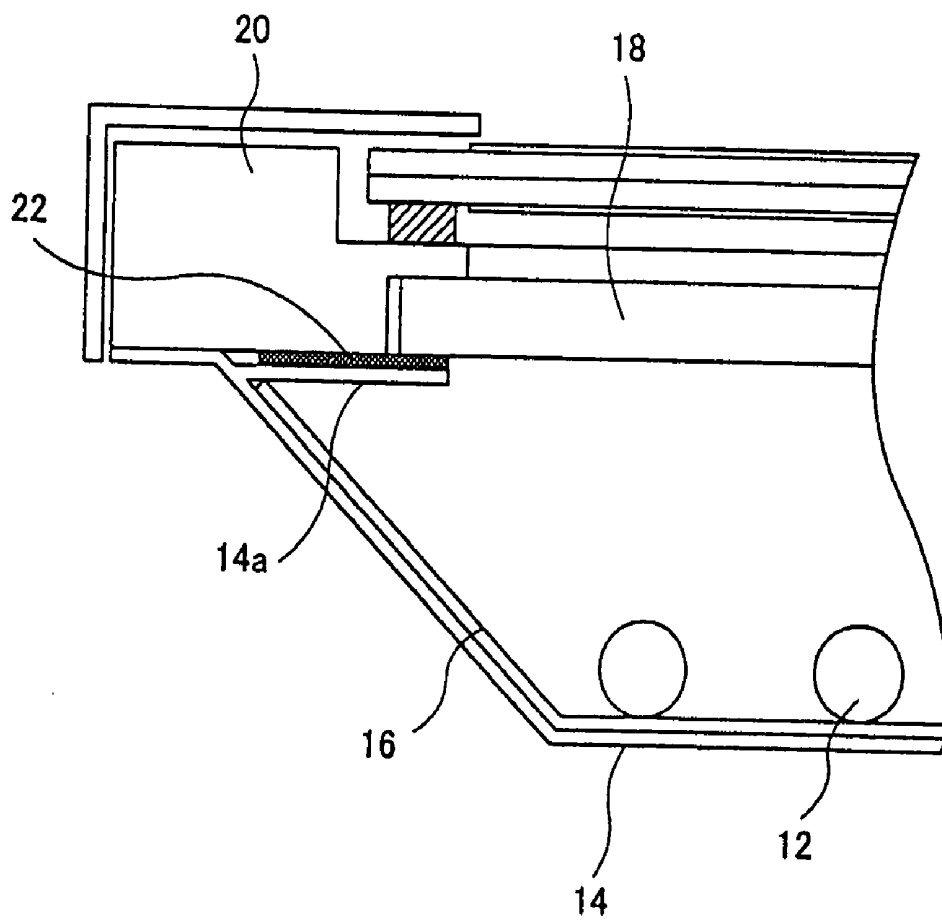

FIG. 7

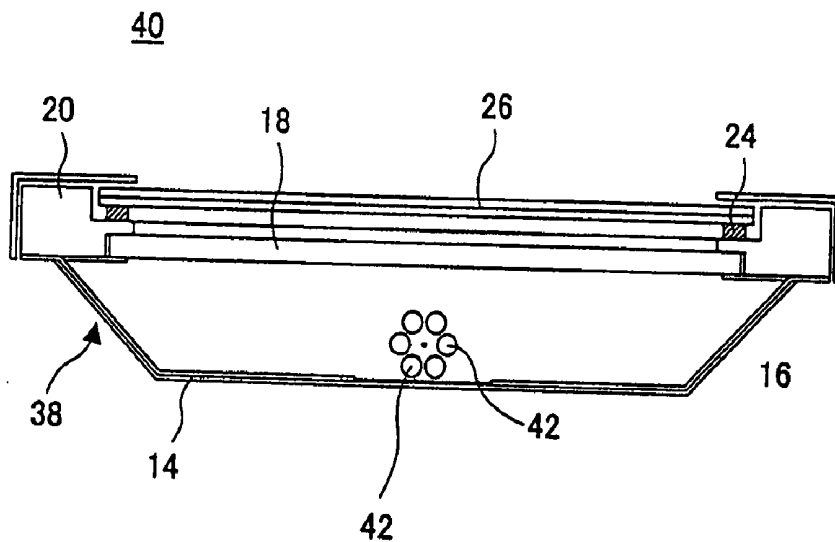
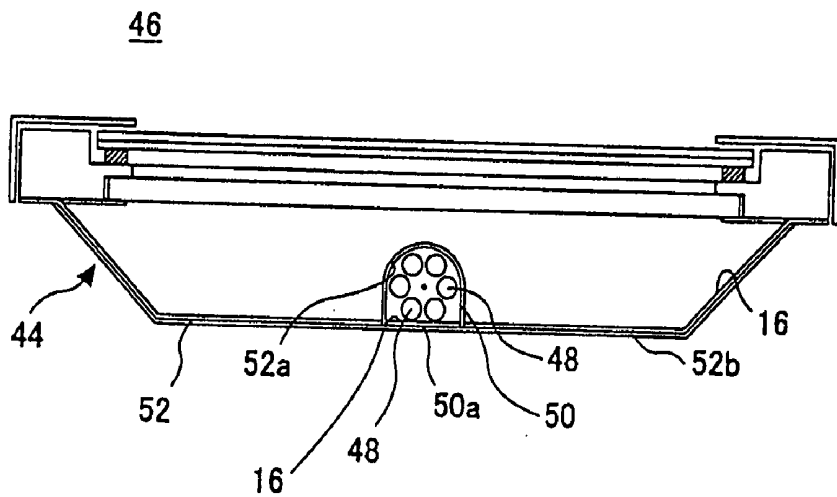

FIG. 8



BACK LIGHT UNIT AND LIQUID CRYSTAL DISPLAY APPARATUS

[0001] This is a divisional of application Ser. No. 10/100,423, filed Mar. 18, 2002.

BACKGROUND OF THE INVENTION

[0002] 1. Field of the Invention

[0003] The present invention generally relates to back light units and liquid crystal displays, and more particularly, to a back light unit and a liquid crystal display having a structure by which a foreign body is prevented from invading the space between the back light unit and a liquid crystal panel.

[0004] 2. Description of the Related Art

[0005] There are several types of display apparatuses, such as a liquid crystal display or a cathode ray tube (CRT).

[0006] Since the liquid crystal display apparatus has several good points such as low consumption of electric power and a small thickness, marketing of the liquid crystal display apparatus has been expanding. Therefore, the liquid crystal display apparatus needs to have various properties more than the CRT.

[0007] The most important property required of the liquid crystal display apparatus is to have high luminance. Particularly, a liquid crystal display is required to have several times the luminance of the related art liquid crystal displays, without increasing manufacturing cost of the liquid crystal display apparatus.

[0008] As a means for realizing the high luminance of the liquid crystal display, up to now, using fluorescent tubes, namely lamps, as a light source, the electrical power provided to the individual fluorescent tubes has been increased, or the number of fluorescent tubes has been increased.

[0009] However, if high luminance of each of the fluorescent tubes is provided, other members in the liquid crystal display apparatus are thermally influenced by the heat generated by the fluorescent tubes. In addition, if the number of the fluorescent tubes is increased, other members in the liquid crystal display apparatus are thermally influenced and miniaturization of the liquid crystal display apparatus is obstructed. Thus, other means are necessary for realizing high luminance of the liquid crystal display apparatus.

[0010] Meanwhile, there are two types of back light units used for the liquid crystal display apparatus, an edge light type and a direct under type.

[0011] FIG. 1 is a schematic illustration of a structure of a related art edge light type back light unit.

[0012] Referring to FIG. 1, the edge light type back light unit 1a includes plural cold cathode fluorescent tubes 3a. Each of the cold cathode fluorescent tubes 3a faces two side surfaces of the light guide plate 2. Reflectors 4a are provided as the reflectors 4a cover circumferences of the cold cathode fluorescent tubes 3a except an irradiation direction of the cold cathode fluorescent tubes 3a. A reflection sheet 5 is provided at a lower surface (back surface) side of the light guide plate 2. A diffuse reflection pattern 6 is formed on a lower surface of the light guide plate 2. The configuration, measurements, and density of the diffuse reflection pattern 6 are arranged appropriately. A diffusion plate (diffusion sheet) 6a is provided at an upper surface side of the light guide plate 2. A prism sheet 7 is further arranged on an upper surface of the diffusion plate 6a. A liquid crystal panel not shown in FIG. 1

is arranged at an upper position of the prism sheet 7 so that the liquid crystal display apparatus can be obtained.

[0013] In the edge light type back light unit 1a, a light radiated from the cold cathode fluorescent tubes 3a irradiates into the light guide plate 2. The light irradiated into the light guide plate 2 is changed to a light having a uniform luminance in a radiation surface of the light guide plate 2 by the diffuse reflection pattern 6. The light radiated from the light guide plate 2 permeates through the diffusion plate 6a and the prism sheet 7 so that a moving direction of the light is controlled. As a result, the liquid crystal panel arranged at the upper position of the prism sheet 7 is irradiated uniformly by the light radiated from the light guide plate 2. Thus, a display having a uniform luminance distribution can be obtained at the liquid crystal panel.

[0014] In this case, if consumption of electricity grows in a narrow space where the cold cathode fluorescent tubes 3a are arranged in order to produce the high luminance of the liquid crystal display, other members in the liquid crystal display apparatus are thermally influenced seriously. In addition, it is difficult to increase the number of the cold cathode fluorescent tubes 3a in the narrow space. In a structure in which the number of the cold cathode fluorescent tubes 3a can be increased, an advantage of the edge light type back light unit, namely a capability of making the liquid crystal display apparatus thin, is obstructed.

[0015] FIG. 2 is a schematic illustration of a structure of the related art direct under type back light unit.

[0016] Referring to FIG. 2, in the direct under type back light unit 1b, the plural cold cathode fluorescent tubes 3b extending to front and back directions in a plane perpendicular to the paper of FIG. 2 are arranged parallel in right and left directions. A lamp house 4b is arranged on a periphery of the line of the plural cold cathode fluorescent tubes 3b as a reflector. A diffusion plate 6b is arranged at an upper position from the cold cathode fluorescent tubes 3b, namely an irradiation side of the cold cathode fluorescent tubes 3b, for example at an upper position of the lamp house 4b. A frame part 8 of the direct under type back light unit 1b has a frame body configuration. The frame part 8 includes a concave part 8a and an opening part 8b. The diffusion plate 6b is grasped between the concave part 8a of the frame 8 and a circumference edge part of the lamp house 4b. An edge part of the frame 8 and a most external circumference edge part of the lamp house 4b are fixed by a screw not shown in FIG. 2. A liquid crystal panel not shown in FIG. 2 is provided on an upper surface of the frame 8 with a spacer 9 having a frame body configuration. The circumference edge part of the liquid crystal panel and the frame part 8 are covered with a frame body not shown in FIG. 2 such as a metal bezel except for a display surface of an upper side of the liquid crystal panel.

[0017] In a case of the direct under type back light unit, it is relatively easy and creates little problem to increase the electrical power or increase the number of the cold cathode fluorescent tubes, as compared with the edge light type back light unit. Hence, it is easy for the direct under type back light unit to produce a high luminance of the liquid crystal display.

[0018] However, in a case of the direct under type back light unit, there are serious problems with regard to an exchange of the cold cathode fluorescent tube and a dispersion of the luminance of the plural cold cathode fluorescent tubes, as compared with the edge light type back light unit.

[0019] That is, in a case of the direct under type back light unit, when the cold cathode fluorescent tube is exchanged, it

is necessary to remove the lamp house in which the plural cold cathode fluorescent tubes are arranged. Hence, it is complicated to exchange the cold cathode fluorescent tubes. Furthermore, in a state where the lamp house and the liquid crystal panel are separated, the diffusion plate is removed at a side where the lamp house is removed by removing the lamp house. Therefore, in this case, the liquid crystal panel faces outside air so that an outside foreign body may adhere to the liquid crystal panel. In addition, as shown in FIG. 3, the spacer 9 of the liquid crystal display apparatus assembled completely has a space shown by arrow a in FIG. 3 in order to have measurement tolerances and efficiency in assembling the liquid crystal display apparatus. In this case, even if a space at the back light unit side is made small so that the foreign particle is prevented from invading, the particle may invade from the liquid crystal panel side.

[0020] When a foreign body adheres to the liquid crystal panel, a problem such as a defect of displaying regarding the liquid crystal panel occurs. In order to prevent the defect, there is an idea to exchange the cold cathode fluorescent tubes in a clean room. However, it is more complicated to exchange the cold cathode fluorescent tubes in a clean room.

[0021] In a case of not only the direct under type back light unit but also the edge light type back light unit, the back light unit is separated based on the need for exchanging the lamps. The same problems in the direct under type back light may occur in the edge light type back light.

[0022] Furthermore, the direct under type back light has a structure in which the cold cathode fluorescent tubes are arranged in parallel. Each of the cold cathode fluorescent tubes irradiates only around the circumferences of the each of the cold cathode fluorescent tubes. Hence, it is difficult to maintain a uniform light level, as compared with the edge light type. Accordingly, if the luminance is reduced due to deterioration of one of the cold cathode fluorescent tubes, the reduced luminance causes a non-uniform luminance distribution of the back light unit and eventually of the liquid crystal panel. Therefore, when the consumption of the electricity increases in order to realize high luminance, non-uniform luminance of the liquid crystal panel occurs frequently since the service life of the cold cathode fluorescent tube is shortened.

SUMMARY OF THE INVENTION

[0023] Accordingly, it is a general object of the present invention to provide a novel and useful back light unit and a liquid crystal display in which one or more of the problems described above are eliminated.

[0024] In addition, there are two more specific objects of the present invention. It is a first object of the present invention to provide a back light unit and the liquid crystal display apparatus wherein it is possible to exchange the lamp easily without adhesion of foreign bodies to the display part such as a liquid crystal panel. It is a second object of the present invention to provide a back light unit and a liquid crystal display apparatus wherein the luminance distribution is not reduced in whole, even if one or more of the plural lamps are deteriorated and the degrees of their luminance are reduced.

[0025] The above objects of the present invention are achieved by a back light unit, including a lamp, a lamp house where the lamp is housed, a diffusion plate provided parallel to a main surface of the lamp house, a display part receiving light irradiated from the lamp and displaying, a frame member that has a structure in which the diffusion plate and the

display part can be housed inside of the frame member and that detachably connects to the lamp house, and a shield member connected in a range from the diffusion plate to the frame member so that a space between the diffusion plate and the frame member is shielded.

[0026] According to the present invention as described above, foreign bodies are prevented from invading from the space between the diffusion plate and the frame member and adhering to the display part, when the lamp house is separated from the frame members and the lamps are exchanged. As a result, the defect of displaying regarding the liquid crystal panel is prevented from occurring when the lamps are exchanged. In addition, it is not necessary to exchange the lamps in a clean room and to handle the lamps carefully.

[0027] In this case, when the shield member is an elastic body such as a silicon gum sheet and a resin sheet, the sealability between the diffusion plate and the frame member improves by putting the shield member between the diffusion plate and the frame member tightly. The shield member and the diffusion plate and the frame member may be connected with the adhesive material.

[0028] The diffusion plate may slide on the shield member.

[0029] According to the present invention as described above, when a deformation of the diffusion plate occurs due to heat or other causes, the deformation of the diffusion plate is absorbed by sliding the diffusion plate against the shield member so that a strain stress does not occur.

[0030] Another object of the present invention is to provide a back light unit, including a lamp, a lamp case wherein a plurality of the lamps being in close formation are housed and that has a surface of an irradiation side made of a transparent material, a lamp house having a main surface wherein the lamp case is detachably connected to an outside surface part situated at a substantially center part of the main surface made of a transparent material, and a diffusion plate provided parallel to the main surface of the lamp house.

[0031] According to the present invention as described above, it is not necessary to remove the lamp house when the lamp is exchanged. Rather, only the lamp case is removed. Hence, a seal structure of the liquid crystal display apparatus may be maintained. As a result, it is possible to prevent foreign bodies from invading at the time of exchanging the lamps, as improvement over the conventional art. In addition, it is easy to exchange the lamps. Furthermore, plural lamps being in close formation form one light source so that there is no luminance distribution even if the luminance of one or more of the lamps is reduced.

[0032] It is another object of the present invention to provide a back light unit, including a lamp, a lamp case wherein a plurality of the lamps being in close formation are housed and that has a surface of an irradiation side made of a transparent material, a lamp house having a concave part made of a transparent material and a main surface wherein the concave part is situated at a substantially center part of the main surface and the lamp case is housed in the concave part, and a diffusion plate provided parallel to the main surface of the lamp house.

[0033] According to the present invention as described above, it is possible to shorten the height of the back light unit by the length of the lamp house housed in the concave part without an outside connection to a main surface of the lamp house.

[0034] It is another object of the present invention to provide a liquid crystal display apparatus, including a back light

unit, and a liquid crystal display mounted on the back light unit, the back light unit including a lamp, a lamp house where the lamp is housed, a diffusion plate provided parallel to a main surface of the lamp house, a display part receiving light irradiated from the lamp and displaying, a frame member that has a structure in which the diffusion plate and the display part can be housed inside of the frame member and that detachably connects to the lamp house, and a shield member connected in a range from the diffusion plate to the frame member so that a space between the diffusion plate and the frame member is shielded.

[0035] According to the present invention as described above, it is possible to obtain a liquid crystal display apparatus in which the effect of the back light unit described above can be provided.

[0036] It is another object of the present invention to provide a liquid crystal display apparatus, including a liquid crystal panel, a back light unit provided on a back surface of the liquid crystal panel, and a spacer member provided at a space between the liquid crystal panel and the frame member of the back light unit and having a frame configuration comprised of four sides, wherein at least one side of the spacer member includes plural divisional parts and an end part of each of the divisional parts comes in contact with an end part of another divisional part.

[0037] As described above, in the related art, the spacer member having a frame body configuration and formed between the liquid crystal panel and the frame member of the back light unit has a partially inevitable space. However, according to the present invention as described above, since the space is shielded, foreign bodies are prevented from invading from the space and adhering to the liquid crystal panel.

[0038] Other objects, features, and advantages of the present invention will become more apparent from the following detailed description when read in conjunction with the accompanying drawings.

BRIEF DESCRIPTION OF THE DRAWINGS

[0039] FIG. 1 is a schematic illustration of a structure of a related art edge light type back light unit;

[0040] FIG. 2 is a schematic illustration of a structure of a related art direct under type back light unit;

[0041] FIG. 3 is a plan view of a spacer of the direct under type back light unit shown in FIG. 2;

[0042] FIG. 4 is a schematic illustration of a structure of a back light unit of a first embodiment of the present invention;

[0043] FIG. 5 is a plan view of a spacer member of the back light unit shown in FIG. 4;

[0044] FIG. 6 is a partially enlarged view of another example of the back light unit according to the first embodiment of the present invention;

[0045] FIG. 7 is a schematic illustration of a structure of a back light unit of a second embodiment of the present invention; and

[0046] FIG. 8 is a schematic illustration of a structure of a back light unit of a third embodiment of the present invention.

DETAILED DESCRIPTION OF THE PREFERRED EMBODIMENTS

[0047] A description will now be given, with reference to the FIGS. 4 through 8, of embodiments of the present invention.

[0048] FIG. 4 is a schematic illustration of a structure of a back light unit of a first embodiment of the present invention.

[0049] Referring to FIG. 4, a back light unit 10 of the first embodiment of the present invention is a direct under type back light unit.

[0050] In the back light unit 10, eight cold cathode fluorescent tubes (lamps) 12 extending to a front and back directions in a plane perpendicular to the paper of FIG. 4 are arranged parallel in right and left directions. The cold cathode fluorescent tubes 12 are housed in a lamp house 14 made of aluminum material, for example. A reflection sheet 16 such as E60L made by TORAY Industries Inc. is applied on an inside surface of the lamp house 14 as a reflector.

[0051] At an upper position of an irradiation side of the cold cathode fluorescent tube 12, the diffusion plate 18 is provided parallel to the main surface 14b of the lamp house 14. A frame member 20 having a frame body configuration is provided in order to support the liquid crystal panel 26. An opening part 20a is situated at the center of the frame member 20. The frame member is, for example, made of polycarbonate resin material. The frame member 20 has a circumference projection part 20b formed toward a side of the opening part 20a. Because of this, the convex parts 20c and 20d having notch configurations are formed on upper and lower parts of the circumference projection part 20b in FIG. 4. The circumference edge part of the diffusion plate 18 is inserted in the concave part 20d. A silicon gum sheet 22 such as a shield member or an elastic body is applied on a lower part in a range from the diffusion plate 18 to the frame member 20 as shown by an arrow A in FIG. 4, by an adhesion layer not shown in FIG. 4. As a result, a circumference edge part of the diffusion plate 18 is united with the frame member 20. Because of this, a space formed between the diffusion plate 18 and the frame member 20 shown by an arrow B in FIG. 4 is shielded by the silicon gum sheet 22. The frame member 20 is fixed at the circumference edge part of the lamp house 14 by a fixing member such as a screw (not shown).

[0052] A spacer member 24 having a frame body configuration is provided on a concave part 20c of the frame member 20. An opening part 24a is situated at a center of the spacer member 24. A liquid crystal panel (display part) 26 that receives light and displays is provided on the spacer member 24 so that the liquid crystal display apparatus can be obtained.

[0053] A frame body 30 such as a metal bezel covers the external circumference of the frame member 20 and fixes the circumference edge part of the liquid crystal panel 26 to the frame body 30. In this case, a space between the frame body 30 and the circumference edge part of the liquid crystal panel 26 is sealed by an elastic sheet, for example. As a result, foreign bodies such as dust are prevented from invading into the inside of the liquid crystal panel 26 primarily.

[0054] Spacer member 24 will be described with reference to FIG. 5. FIG. 5 is a plan view of the spacer member 24 of the back light unit shown in FIG. 4.

[0055] Referring to FIG. 5, the spacer member 24 has a frame configuration formed by four sides having approximately the same measurements.

[0056] Three of frame segments (side construction members) 32a through 32c are prepared in order to construct three sides of the four-sided spacer member 24. Each frame segment 32a through 32c has substantially the same length. Another frame segment 32d having two divisional parts 32d-1 and 32d-2 is prepared in order to construct the fourth side of the spacer member 24. The length where the divisional

parts **32d-1** and **32d-2** are connected is longer than the lengths of other sides (frame segments **32a** through **32c**). Notch parts **34a** and **34b** having step configurations as connection parts are formed on side surfaces of respective end parts of the two of divisional parts **32d-1** and **32d-2**. The notch parts **34a** and **34b** face each other. Adhesion is applied on one side surface of the end parts of the frame segments **32a** through **32d** to fix these members. The remaining side may be divided into more than three parts. In this case, the notch parts having a step configuration as a connection part may be formed on both end parts of at least one divisional part.

[0057] End parts of the three frame segments **32a** through **32c** come in contact so that the spacer member **24** has a rectangle configuration not having one side. And then, one end part of the divisional part **32d-1** comes in contact with an end part of the frame segment **32a**. One end part of the divisional part **32d-2** comes in contact with an end part of the frame segment **32c**. Furthermore, other end parts of two divisional parts **32d-1** and **32d-2** come in contact with each other. In this case, the notch parts **34a** and **34b** come in contact with each other so that the end parts of the two divisional parts **32d-1** and **32d-2** are sealed completely. As a result, the inside and the outside of the spacer member **24** are insulated from each other completely.

[0058] Because of this, it is possible in the present invention to prevent the partially inevitable space formed at the connecting parts of the four sides of the spacer member **24** in the related art from forming. It is possible to apply the above mentioned structure of the spacer member **24** to not only the direct under type back light unit but also the edge light type back light unit, and the edge light type back light unit also can obtain the same effect as the direct under type back light unit.

[0059] Since basic functions of the back light unit **10** and the liquid crystal display apparatus **28** of the present invention are the same as in the related art respectively, an explanation thereof will be omitted.

[0060] In the back light unit **10** and the liquid crystal display apparatus **28** according to the first embodiment, a space formed between the diffusion plate and the frame member is sealed by the silicon gum sheet. Accordingly, when the lamp house is separated from the frame member and the cold cathode fluorescent tube is exchanged, a foreign body is prevented from invading and adhering to the liquid crystal panel. Hence, a defect of displaying can be avoided. Therefore, it is not necessary to remove the lamp house in a clean room and to handle the lamps carefully in order to prevent a foreign body from invading. If a foreign body invades from the space formed between the diffusion plate and the frame member and the lamp house, the foreign body can be prevented from adhering to the liquid crystal panel since the spacer member has a complete seal structure.

[0061] FIG. 6 is a partially enlarged view of another example of the back light unit according to the first embodiment of the present invention. Referring to FIG. 6, a circumference projection part **14a** projecting to an inside of the lamp house **14** may be provided at a circumference edge part of the lamp house **14**, so that the silicon gum sheet **22** may be put between the circumference projection part **14a** and the diffusion plate **18** and the frame member **20**. Because of this, it is possible to improve the sealability between the diffusion plate **18** and the frame member **20**. In this case, a tape made of resin such as polyethylene terephthalate (PET), polypropylene (PP), or polyethylene (PE) may be used instead of the silicon gum sheet **22**.

[0062] In this case, if the adhesion layer is not provided on a part of the silicon gum sheet **22** contacting the diffusion plate **18** and the diffusion plate **18** can slide against the silicon gum sheet **22**, the deformation of the diffusion plate **18** due to heat or other causes is prevented by sliding the diffusion plate **18** against the silicon gum sheet **22**. As a result of this, a strain stress may be prevented.

[0063] Next, a description of a back light unit and a liquid crystal display apparatus of a second embodiment of the present invention will be given, with reference to the FIG. 7. FIG. 7 is a schematic illustration of a structure of a back light unit of a second embodiment of the present invention.

[0064] Since basic structures of a back light unit **38** and a liquid crystal display apparatus **40** are same as the back light unit **10** and the liquid crystal display apparatus **28** respectively, parts in FIG. 7 that are the same as the parts shown in FIG. 4 are given the same reference numerals, and explanation thereof will be omitted.

[0065] In the back light unit **38**, plural cold cathode lamps **42** being in close formation are provided at a substantially center part of a main surface of the lamp house **14**.

[0066] In the back light unit **38** and the liquid crystal display apparatus **40** according to the second embodiment of the present invention, the plural cold cathode fluorescent tubes being in close formation form one light source. Accordingly, even if the luminance of one part of the cold cathode fluorescent tube is reduced, a non-uniform light radiated from the back light unit and a luminance distribution of the liquid crystal panel are not caused. Accordingly, even if luminance of one part of the cold cathode fluorescent tube is reduced, it is not necessary to exchange the back light unit immediately. Hence, a number of exchanging the back light unit decreases so that the foreign bodies have less chance to invade the liquid crystal panel.

[0067] Next, a description of a back light unit and a liquid crystal display apparatus of a third embodiment of the present invention will be given, with reference to the FIG. 8. FIG. 8 is a schematic illustration of a structure of a back light unit of the third embodiment of the present invention

[0068] Since basic structures of a back light unit **44** and a liquid crystal display apparatus **46** are same as the back light unit **38** and the liquid crystal display apparatus **40**, respectively parts in FIG. 8 that are the same as the parts shown in FIG. 7 are given the same reference numerals, and explanation thereof will be omitted.

[0069] In the back light unit **44**, plural cold cathode fluorescent tubes **48** are housed in the lamp case **50**. The lamp case **50** extends to front and back directions in a plane perpendicular to the paper of FIG. 8. The lamp case **50** has a configuration fitting a formation of the plural cold cathode fluorescent tubes **48** arranged as a circumferential configuration. That is, the lamp case **50** long-extending to front and back directions in a plane perpendicular to the paper of FIG. 8 has a cross sectional configuration of a half of an ellipse. The lamp case **50** is made of polycarbonate (PC) resin for example. The irradiation direction of the cold cathode fluorescent tubes is made transparent. The reflection sheet **16** as described above, for example, is applied on a back surface of the lamp house **50** as a reflector.

[0070] On the other hand, the concave part **52a**, long-extending to front and back directions in a plane perpendicular to the paper of FIG. 8 and having a configuration fitting to the lamp case **50**, is formed at a substantially center part of the main surface **52b** of the lamp house **52**. A reflection sheet **16**

is not applied on an inside wall part of the concave part **52a** so that the inside wall part of the concave part **52a** is made transparent. Hence, the light from the cold cathode fluorescent tubes **48** permeates through the concave part **52a**.

[0071] The lamp case **50** where the cold cathode fluorescent tubes **48** are housed is connected to the concave part **52a** of the lamp house **52** detachably by proper fixing means. Because of this, the bottom surface **50a** of the lamp case **50** and the main surface **52b** of the lamp house **52** are the same surface.

[0072] The back light unit **44** and the liquid crystal display apparatus **46** according to the third embodiment of the present invention have the same effect as the effect obtained by the back light unit **38** and the liquid crystal display apparatus **40** of the second embodiment of the present invention. In addition, when the cold cathode fluorescent tube is exchanged, it is not necessary to remove the lamp house. It is necessary to remove just only the lamp case. Accordingly, it is possible to prevent a foreign body from invading when the cold cathode fluorescent tube is exchanged. In addition, it is possible to exchange the cold cathode fluorescent tube easily. Furthermore, the miniaturization of the liquid crystal apparatus is not obstructed by the lamp case.

[0073] The present invention is not limited to these embodiments, but variations and modifications may be made without departing from the scope of the present invention. For instance, in the back light unit **44** of the third embodiment of the present invention, it is not necessary to form the concave part in the main surface of the lamp house. Rather, a lamp case having a rectangular parallelepiped configuration may be connected from outside to the lower surface of the main surface of the lamp house for instance.

[0074] This patent application is based on Japanese priority patent application No. 2001-360962 filed on Nov. 27, 2001, the entire contents of which are hereby incorporated by reference.

What is claimed is:

1. A back light unit, comprising:

- a lamp;
- a lamp house where the lamp is housed;
- a diffusion plate provided parallel to a main surface of the lamp house; and
- a lamp case in which a plurality of the lamps being in close formation are provided at a substantially center part of a main surface of the lamp house.

* * * * *

专利名称(译)	背光单元和液晶显示装置		
公开(公告)号	US20080174543A1	公开(公告)日	2008-07-24
申请号	US11/899082	申请日	2007-09-04
[标]申请(专利权)人(译)	永谷晋平		
申请(专利权)人(译)	永谷晋平		
当前申请(专利权)人(译)	永谷晋平		
[标]发明人	NAGATANI SHINPEI		
发明人	NAGATANI, SHINPEI		
IPC分类号	G09G3/36 G02F1/1333 F21S2/00 F21V8/00 F21Y103/00 G02F1/13357		
CPC分类号	G02F1/133604 G02F2203/68 G02F2001/133317 G02F2001/133311		
优先权	2001360962 2001-11-27 JP		
其他公开文献	US8031165		
外部链接	Espacenet USPTO		

摘要(译)

背光单元包括灯，容纳灯的灯罩，平行于灯罩主表面设置的扩散板，接收从灯照射并显示的光的显示部分，具有结构的框架构件其中扩散板和显示部分可以容纳在框架构件的内部并且可拆卸地连接到灯罩，以及屏蔽构件，其连接在从扩散板到框架构件的范围内，使得扩散板之间的空间并且框架构件被屏蔽。

