



US009104058B2

(12) **United States Patent**  
**Shives et al.**

(10) **Patent No.:** **US 9,104,058 B2**  
(45) **Date of Patent:** **Aug. 11, 2015**

(54) **OPTIMIZED FRAME SYSTEM FOR A LIQUID CRYSTAL DISPLAY DEVICE**

(56) **References Cited**

(75) Inventors: **Gary D. Shives**, Brunswick, OH (US);  
**William Varela**, Parma Heights, OH (US)

(73) Assignee: **GrafTech International Holdings Inc.**, Parma, OH (US)

(\*) Notice: Subject to any disclaimer, the term of this patent is extended or adjusted under 35 U.S.C. 154(b) by 1493 days.

U.S. PATENT DOCUMENTS

1,137,373 A	4/1915	Alysworth	
3,404,061 A	10/1968	Shane et al.	161/125
3,492,197 A	1/1970	Olstowski et al.	161/183
3,560,155 A *	2/1971	Olstowski et al.	423/448
3,981,427 A	9/1976	Brookes	228/122
4,355,684 A	10/1982	Caines	165/154
4,895,713 A	1/1990	Greinke et al.	423/448
4,914,551 A	4/1990	Anschel et al.	361/389
5,100,737 A	3/1992	Colombier et al.	428/612
5,128,209 A	7/1992	Sakai et al.	428/421
5,482,520 A	1/1996	Alam et al.	44/336

(Continued)

(21) Appl. No.: **11/223,804**

FOREIGN PATENT DOCUMENTS

(22) Filed: **Sep. 9, 2005**

EP	1519217 A1	3/2005
WO	PCTUS0007977 A2	10/2000
WO	2005038761 A2	4/2005

(65) **Prior Publication Data**

OTHER PUBLICATIONS

US 2006/0292461 A1 Dec. 28, 2006

Extract from the Wikipedia database, headword "Wärmeleitfähigkeit" ["Thermal conductivity"]. Wärmeleitfähigkeit—Wikipedia. <http://de.wikipedia.org/wiki/W%C3%A4rmeleitf%C3%A4higkeit>.

(Continued)

**Related U.S. Application Data**

*Primary Examiner* — Timothy L Rude

(63) Continuation-in-part of application No. 11/167,935, filed on Jun. 27, 2005.

(74) *Attorney, Agent, or Firm* — Buchanan, Ingersoll & Rooney PC

(51) **Int. Cl.**  
**G02F 1/1333** (2006.01)  
**G02F 1/1335** (2006.01)  
**H05K 7/20** (2006.01)

(57) **ABSTRACT**

(52) **U.S. Cl.**  
CPC .... **G02F 1/133385** (2013.01); **G02F 1/133603** (2013.01); **H05K 7/20963** (2013.01); **G02F 2001/133628** (2013.01)

An image display device comprising an image display panel, a frame system including a framework operatively engaging the image display panel and a plurality of electronic components operatively engaging the framework, heat dispersion material operatively engaging the framework and in operative thermal contact with the electronic components, where the frame system exhibits a support factor of less than about 375 mm-W/m° K.

(58) **Field of Classification Search**  
CPC ..... G02F 1/1333  
USPC ..... 349/58-60; 361/681  
See application file for complete search history.

**16 Claims, 5 Drawing Sheets**

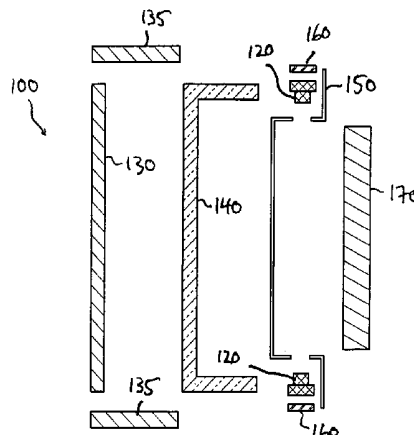

(56)

## References Cited

## U.S. PATENT DOCUMENTS

5,499,120 A *	3/1996	Hansen	349/62
5,644,327 A	7/1997	Onyskevych et al.	345/80
5,773,113 A	6/1998	Akhter	428/41.8
5,831,374 A	11/1998	Morita et al.	313/46
5,869,919 A *	2/1999	Sato et al.	313/17
5,902,762 A	5/1999	Mercuri et al.	501/99
6,007,209 A	12/1999	Pelka	
6,060,166 A	5/2000	Hoover et al.	428/408
6,075,701 A	6/2000	Ali et al.	361/704
6,128,209 A	10/2000	Kuroki	365/63
6,131,651 A *	10/2000	Richey, III	165/185
6,245,400 B1	6/2001	Tzeng et al.	428/40.1
6,407,922 B1	6/2002	Eckblad et al.	361/704
6,409,562 B1 *	6/2002	Asano et al.	445/2
6,432,497 B2	8/2002	Bunyan	428/40.1
6,482,520 B1 *	11/2002	Tzeng	428/408
6,503,626 B1 *	1/2003	Norley et al.	428/408
6,538,892 B2	3/2003	Smalc	361/710
6,621,482 B2 *	9/2003	Fuller	345/102
6,737,790 B2	5/2004	Seki	313/47
6,758,263 B2	7/2004	Krassowski et al.	165/185
6,777,086 B2	8/2004	Norley et al.	428/408
6,835,453 B2	12/2004	Greenwood et al.	428/343
6,856,076 B2	2/2005	Kim et al.	313/46
7,102,703 B1 *	9/2006	Mathew et al.	349/60
7,138,029 B2 *	11/2006	Norley et al.	156/249
7,150,914 B2 *	12/2006	Clovesko et al.	428/408
7,160,619 B2 *	1/2007	Clovesko et al.	428/408
7,276,273 B2 *	10/2007	Clovesko et al.	428/40.1
7,303,820 B2 *	12/2007	Capp et al.	428/408
7,306,847 B2 *	12/2007	Capp et al.	428/408
7,385,819 B1 *	6/2008	Shives et al.	361/704
7,658,999 B2 *	2/2010	Clovesko et al.	428/408
7,666,270 B1 *	2/2010	Smalc et al.	156/249
2002/0140880 A1 *	10/2002	Weindorf et al.	349/70
2002/0157818 A1	10/2002	Norley et al.	
2002/0163076 A1	11/2002	Tzeng et al.	
2002/0164483 A1 *	11/2002	Mercuri et al.	428/408
2002/0166658 A1 *	11/2002	Norley et al.	165/185
2004/0257307 A1	12/2004	Bae et al.	
2005/0007516 A1	1/2005	Hong	
2005/0046618 A1	3/2005	Kim et al.	
2005/0062382 A1 *	3/2005	Kim et al.	313/44
2005/0068738 A1	3/2005	Kim et al.	
2005/0077000 A1 *	4/2005	Norley et al.	156/249
2005/0088097 A1	4/2005	Bae et al.	
2005/0122019 A1	6/2005	Bae	
2005/0174054 A1	8/2005	Kang et al.	
2005/0194900 A1	9/2005	Kim et al.	
2006/0103774 A1 *	5/2006	Han et al.	349/58

## OTHER PUBLICATIONS

Collection of sheets from the Universität der Bundeswehr München to show the temperature dependency of the thermal conductivity of solids.

"Alu-Floor" technical datasheet. Issued: 01 Alu-info 10-99; 09 Alu-Floor 12-99.

International Application No. PCT/US02/16730, WO 02/096615, Dec. 5, 2002.

International Application No. PCT/US02/39749, WO 03/051772, Jun. 26, 2003.

Japan Unexamined Patent Publication Hei 10-56114, JP1998056114A, Feb. 24, 1998.

Japan Unexamined Patent Publication Hei 11-179830, JP1999179830A, Jul. 6, 1999.

\* cited by examiner

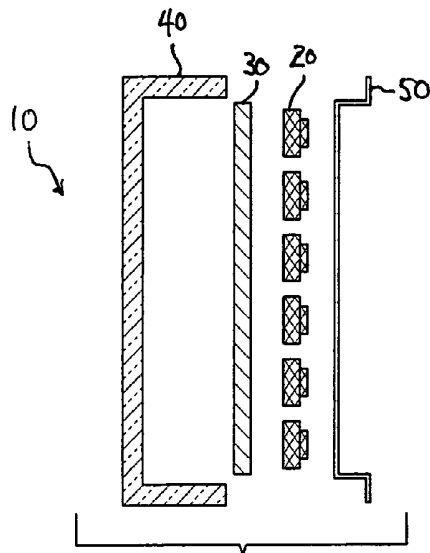

FIG. 2

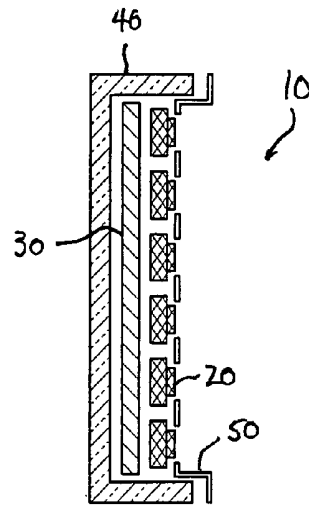

FIG. 3

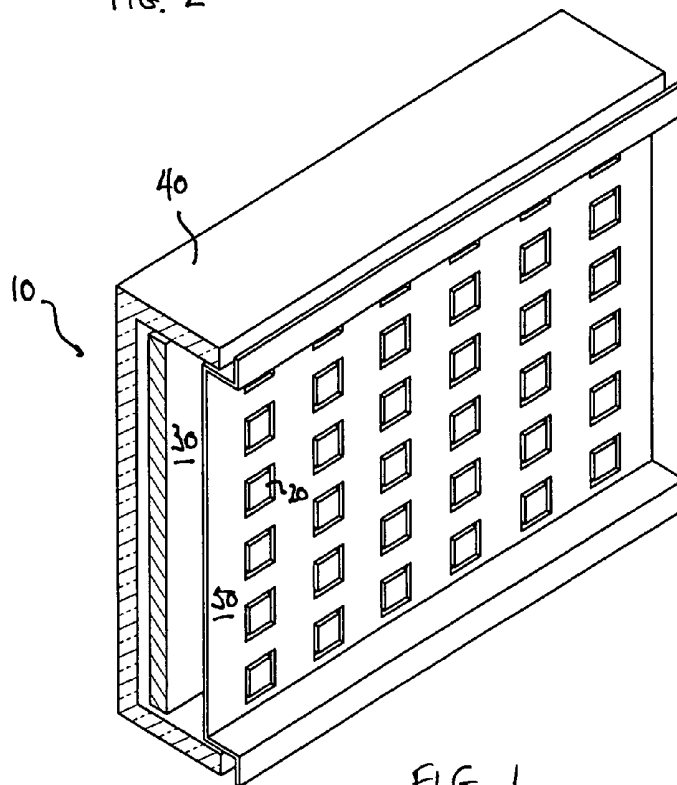

FIG. 1

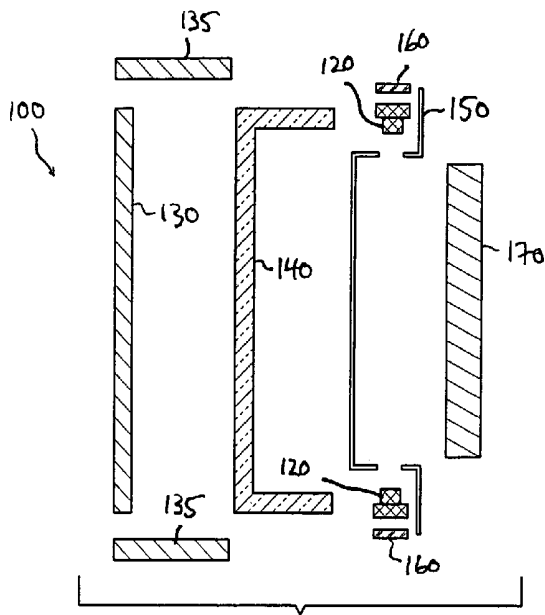

FIG. 5

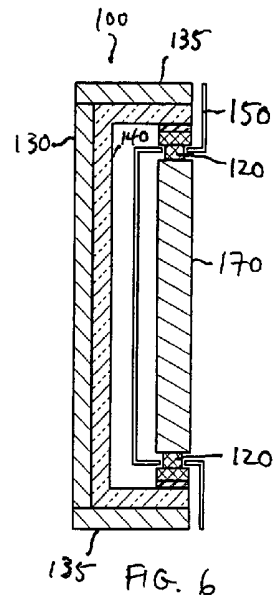

FIG. 6

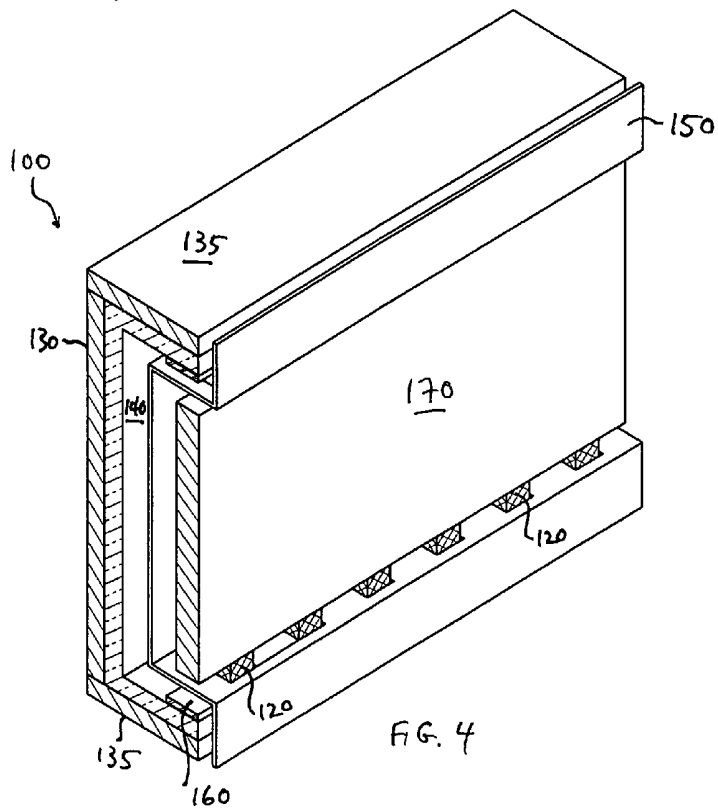

FIG. 4

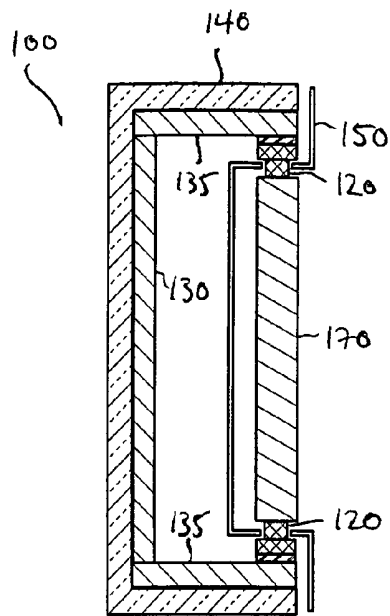

FIG. 7

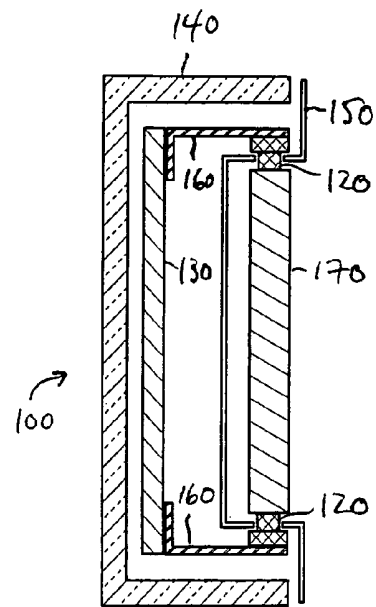

FIG. 8

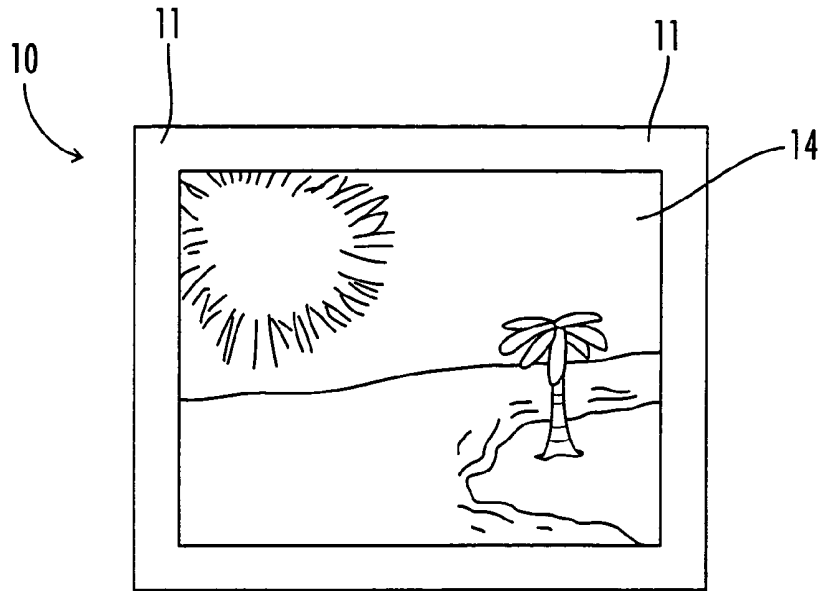

FIG. 9

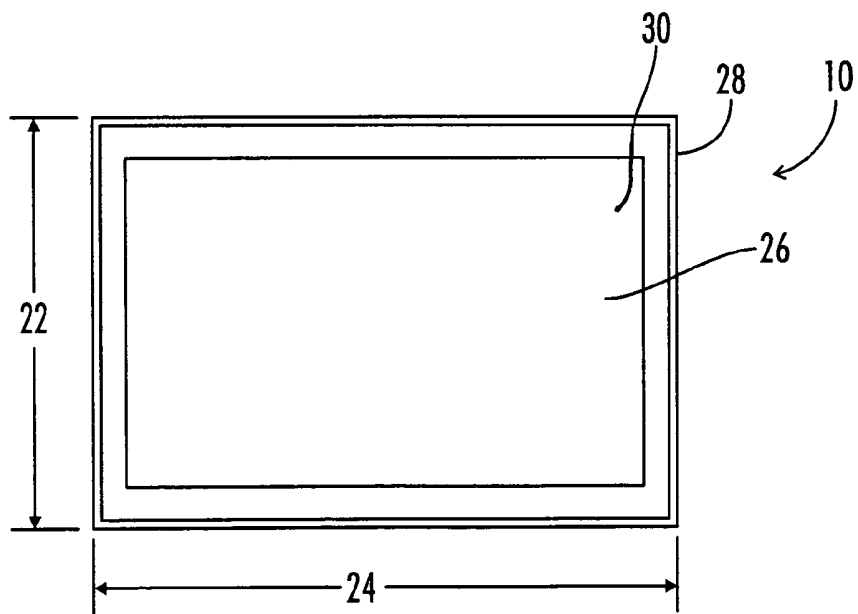

FIG. 11

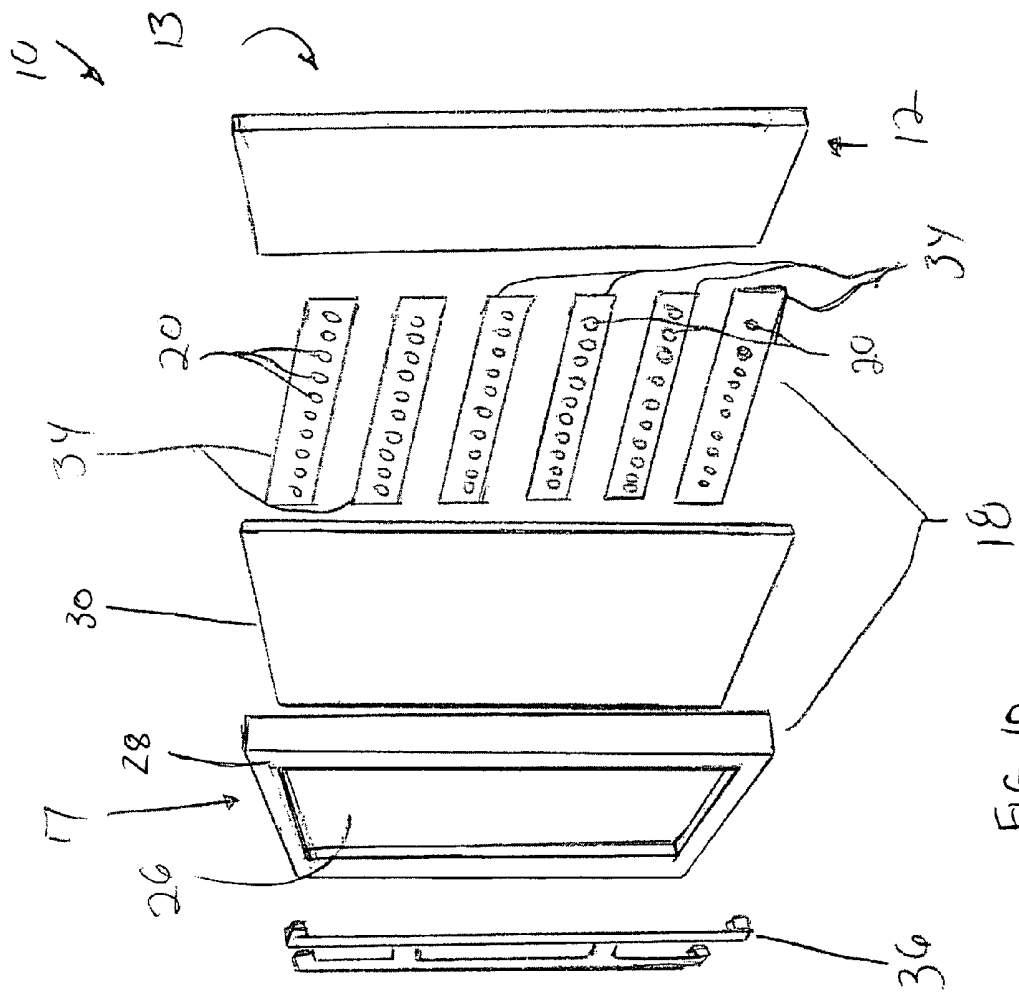

FIG. 10

## OPTIMIZED FRAME SYSTEM FOR A LIQUID CRYSTAL DISPLAY DEVICE

### RELATED APPLICATION

This application is a continuation-in-part of copending and commonly assigned U.S. patent application having Ser. No. 11/167,935, entitled "Optimized Frame System For A Display Device," filed in the names of Shives et al. on Jun. 27, 2005, the disclosure of which is incorporated herein by reference.

### TECHNICAL FIELD

The present invention relates to an optimized frame system used in conjunction with a heat spreader in a display device, such as a liquid crystal display (LCD), and the like, and the design and use of the frame system in view of the unique thermal issues occasioned by these devices.

### BACKGROUND OF THE ART

A liquid crystal display, or LCD, is a display apparatus that utilizes an image display panel formed of two transparent sheets of polarizing material separated by a liquid containing rod-shaped crystals where the polarizing axes of the two sheets are aligned perpendicular to each other. The LCD is constructed to display an image by passing an electric current through the liquid that causes the crystals to align to block light. Each crystal can be controlled individually and basically acts like a shutter. When the current is applied to specific pixel-like areas, those crystals align to create dark area, or images. The dark areas are combined with light areas to create text and images on the panel. LCD panels do not emit light but are usually back-lit or side-lit for better viewing of the text and images on the display panel. In general, back-lit LCDs are used for larger screens (generally considered larger than about 24 inches in the diagonal), whereas side-lit LCDs are used for smaller screens, usually in conjunction with optics for light distribution so the light does not appear to come from the side.

In a liquid crystal display, the back or side lighting used to illuminate and enhance the viewing of the image display panel generates heat and thus constitutes a source of heat, which causes the temperature of the liquid crystal display as a whole to rise. Traditionally, a single light source, or a plurality of heat generating light sources, such as fluorescent lights, such as cold cathode fluorescent lamps (CCFLs) or flat fluorescent lamps (FFLs), have been used as the illuminating light. Recently, arrays of light-emitting diodes, or LED's, are being used as the light source to eliminate environmental issues occasioned by fluorescent lamps and to improve the range of colors capable of being displayed.

The heat generated in the light source is detrimental to the operation and viewing of a liquid crystal display. The light source(s) discharge heat that is transferred to the image display panel, other electrical components in liquid crystal display, and the support structure of the liquid crystal display. Indeed, some of the electrical components in the display panel are themselves heat sources, which compounds the problem. However, these other components of the liquid crystal display normally possess poor thermal spreading properties and are not normally designed to dissipate heat away from the light source, especially in directions parallel to the image display panel face.

In addition, the illuminating light of a liquid crystal display remains in an energized state and at a consistent power level

regardless of the image characteristics on the viewing panel. Variances in the image are control by the arrangement and alignment of the crystals in the image display panel. As such, the components of the liquid crystal display are in need of relief from the constant heat generated by the illuminating light. The constant heat generation can accelerate thermal deterioration of the liquid crystal material from which the display is formed and shorten the useful lifespan of the liquid crystal display device. Heat may also negatively affect the refresh rate of the screen.

The use of so-called "high orientation graphite film" as thermal interface materials for plasma display panels to fill the space between the back of the panel and a heat sinking unit is suggested by Morita, Ichiyanagi, Ikeda, Nishiki, Inoue, Komyoji and Kawashima in U.S. Pat. No. 5,831,374. However, the disclosure is centered on the use of pyrolytic graphite as the graphitic material and makes no mention of the use or distinct advantages of sheets of compressed particles of exfoliated graphite. In addition, the use of a heavy aluminum heat sinking unit is a critical part of the Morita et al. invention. In addition, U.S. Pat. No. 6,482,520 to Tzeng discloses the use of sheets of compressed particles of exfoliated graphite as heat spreaders (referred to in the patent as thermal interfaces) for a heat source such as an electronic component. Indeed, such materials are commercially available from Advanced Energy Technology Inc. of Lakewood, Ohio as its eGraf® SpreaderShield class of materials. The graphite heat spreaders of Tzeng are positioned between a heat generating electronic component and, advantageously, a heat sink, to increase the effective surface area of the heat generating component; the Tzeng patent does not address the specific thermal issues occasioned by display devices.

Graphites are made up of layer planes of hexagonal arrays or networks of carbon atoms. These layer planes of hexagonally arranged carbon atoms are substantially flat and are oriented or ordered so as to be substantially parallel and equidistant to one another. The substantially flat, parallel equidistant sheets or layers of carbon atoms, usually referred to as graphene layers or basal planes, are linked or bonded together and groups thereof are arranged in crystallites. Highly ordered graphites consist of crystallites of considerable size: the crystallites being highly aligned or oriented with respect to each other and having well ordered carbon layers. In other words, highly ordered graphites have a high degree of preferred crystallite orientation. It should be noted that graphites possess anisotropic structures and thus exhibit or possess many properties that are highly directional e.g. thermal and electrical conductivity and fluid diffusion.

Briefly, graphites may be characterized as laminated structures of carbon, that is, structures consisting of superposed layers or laminae of carbon atoms joined together by weak van der Waals forces. In considering the graphite structure, two axes or directions are usually noted, to wit, the "c" axis or direction and the "a" axes or directions. For simplicity, the "c" axis or direction may be considered as the direction perpendicular to the carbon layers. The "a" axes or directions may be considered as the directions parallel to the carbon layers or the directions perpendicular to the "c" direction. The graphites suitable for manufacturing flexible graphite sheets possess a very high degree of orientation.

As noted above, the bonding forces holding the parallel layers of carbon atoms together are only weak van der Waals forces. Natural graphites can be treated so that the spacing between the superposed carbon layers or laminae can be appreciably opened up so as to provide a marked expansion in the direction perpendicular to the layers, that is, in the "c"

direction, and thus form an expanded or intumesced graphite structure in which the laminar character of the carbon layers is substantially retained.

Graphite flake which has been greatly expanded and more particularly expanded so as to have a final thickness or "c" direction dimension which is as much as about 80 or more times the original "c" direction dimension can be formed without the use of a binder into cohesive or integrated sheets of expanded graphite, e.g. webs, papers, strips, tapes, foils, mats or the like (typically referred to as "flexible graphite"). The formation of graphite particles which have been expanded to have a final thickness or "c" dimension which is as much as about 80 times or more the original "c" direction dimension into integrated flexible sheets by compression, without the use of any binding material, is believed to be possible due to the mechanical interlocking, or cohesion, which is achieved between the voluminosly expanded graphite particles.

In addition to flexibility, the sheet material, as noted above, has also been found to possess a high degree of anisotropy with respect to thermal and electrical conductivity and fluid diffusion, comparable to the natural graphite starting material due to orientation of the expanded graphite particles and graphite layers substantially parallel to the opposed faces of the sheet resulting from very high compression, e.g. roll pressing. Sheet material thus produced has excellent flexibility, good strength and a very high degree of orientation.

Briefly, the process of producing flexible, binderless anisotropic graphite sheet material, e.g. web, paper, strip, tape, foil, mat, or the like, comprises compressing or compacting under a predetermined load and in the absence of a binder, expanded graphite particles which have a "c" direction dimension which is as much as about 80 or more times that of the original particles so as to form a substantially flat, flexible, integrated graphite sheet. The expanded graphite particles that generally are worm-like or vermiform in appearance, once compressed, will maintain the compression set and alignment with the opposed major surfaces of the sheet. The density and thickness of the sheet material can be varied by controlling the degree of compression. The density of the sheet material can be within the range of from about 0.04 g/cm<sup>3</sup> to about 2.0 g/cm<sup>3</sup>. The flexible graphite sheet material exhibits an appreciable degree of anisotropy due to the alignment of graphite particles parallel to the major opposed, parallel surfaces of the sheet, with the degree of anisotropy increasing upon roll pressing of the sheet material to increase orientation. In roll pressed anisotropic sheet material, the thickness, i.e. the direction perpendicular to the opposed, parallel sheet surfaces comprises the "c" direction and the directions ranging along the length and width, i.e. along or parallel to the opposed, major surfaces comprises the "a" directions and the thermal, electrical and fluid diffusion properties of the sheet are very different, by orders of magnitude, for the "c" and "a" directions.

While the use of sheets of compressed particles of exfoliated graphite (i.e., flexible graphite) has been suggested as thermal spreaders, thermal interfaces and as component parts of heat sinks for dissipating the heat generated by a heat source (see, for instance, U.S. Pat. Nos. 6,245,400; 6,482,520; 6,503,626; and 6,538,892), the use of graphite materials has heretofore been independent, and not viewed as interrelated with other components, such as the frame system of display panels.

Conventional display devices typically utilize a thick, heavy metal support member (often a thick aluminum sheet, or set of multiple sheets) to which is attached both the display panel unit, the light source (which, in the case of LEDs, may

be mounted to printed circuit boards, such as a metal core printed circuit board (PCB) with a thermally conductive dielectric material) and associated electronic components. Heat passing from these heat sources contributes to uneven temperature distributions created on the panel unit itself, which adversely affects the image presented on the display panels as well as display panel reliability.

The conventional support member provides both a mechanical function (i.e., for mounting the panel unit and associated electronics), as well as a thermal function (i.e., to help sink and spread heat generated by the light source(s) and/or the associated electronics). Accordingly, the support member is typically fabricated from a solid sheet of aluminum, on the order of about 2.0 mm thick. Expressed another way, the conventional display panel having a support member exhibits a support factor of about 440 mm-W/m<sup>o</sup> K or higher. The support factor is determined by multiplying the thickness of the support member present in the display panel by its in-plane thermal conductivity (thus, a 2.0 mm sheet of aluminum has a support factor of 440 mm-W/m<sup>o</sup> K, since the in-plane thermal conductivity of the high thermal conductivity aluminum typically employed is 220 W/m<sup>o</sup> K). It will be recognized that, since most metals are relatively thermally isotropic, the in-plane thermal conductivity is not substantially different from the through-plane thermal conductivity of the material.

A support member such as this can add a significant amount of weight, and can be expensive and difficult to construct, due to physical requirements, the need for many threaded mounting features for the electronics, and the high cost of high thermal conductivity aluminum sheet. Additionally, a framework (often made from steel or aluminum) is used to add further mechanical support to the support member, and allow for a, robust mounting means for attachment of the display panel to a wall bracket or stand unit. Together, the framework and support member constitute a frame system in the conventional display panel.

LCD device manufacturers are under extreme pressure to reduce the cost and weight of their existing display solutions, while there has simultaneously been a desire to increase the brightness and luminous efficiency of the panel units. This can mean more power being sent to the light sources, which increases the thermal load on the system and requires additional heat dissipation capabilities within the display units. Active cooling solutions, such as fans and/or heat pipes, are undesirable due to unreliability, noise, and the fact that they contribute negatively to the cost and weight of the system. In addition to increasing brightness and luminous efficiency of the displays, display manufacturers are also under increasing pressure to produce larger panel sizes, which tends to increase the weight of the frame system (especially the support member) proportionately.

Thus, what is desired is a light weight and cost effective frame system for display devices, especially one which provides enhanced heat transfer capabilities, yet is structurally sound enough to provide both the attachment for the panel units and associated electronics, as well as the structural integrity for mounting and supporting the display device itself. The desired frame system reduces or eliminates the need for a support member, especially one formed of high conductivity aluminum.

#### SUMMARY OF THE INVENTION

Accordingly, it is an object of the present invention to provide a frame system for a display device such as a liquid crystal display or the like, which is lightweight and structurally sound.

Another object of the present invention is to provide a frame system for a display device which comprises a framework having a low support factor.

Another object of the present invention is to provide a display device which comprises a heat dispersion material, sometimes referred to as a heat spreader, disposed adjacent to a heat generating source, such as an array of light-emitting diodes, cold cathode fluorescent lamps or flat fluorescent lamps, of the display device.

Still another object of the present invention is to provide a frame system for a display device comprising a framework that includes a perimeter edge providing structural integrity to the display device.

Another object of the present invention is to provide a frame for a display device having an internal aperture to facilitate heat transfer and dissipation by the heat dispersion material within the display device.

Still another object of the present invention is to provide a frame system for a display device comprising a support member other than a heavy aluminum sheet or set of sheets.

These objects, and others which will be apparent to the skilled artisan upon reading the following description, can be achieved by providing an image display device comprising an image display panel, one or more heat-generating light sources, a frame system exhibiting a support factor of less than about 375 mm-W/m<sup>2</sup> K, and heat dispersion material in operative thermal contact with at least some of the heat-generating light sources; advantageously, the heat dispersion material operatively engages the frame system. In a preferred embodiment the frame system includes a framework operatively engaging the image display panel and a plurality of light sources, such as light-emitting diodes, operatively engaging the framework.

More preferably, the frame system has a support factor less than about 150 mm-W/m<sup>2</sup> K, and in a most preferred embodiment the frame system exhibits a support factor of 0 mm-W/m<sup>2</sup> K; that is, the frame system has no support member altogether.

The LCD can be a back-lit LCD or a side-lit LCD. In a back-lit LCD, rows of light sources, such as PCB-mounted LEDs, sit directly behind the LCD panel to provide direct lighting to the rear of the LCD panel. In side-lit LCDs, the light sources are arrayed along the sides of the LCD panel, and optics (sometimes referred to as light guides) are usually employed to even out the light distribution across the rear of the LCD panel so the light does not appear to be originating from or more pronounced at the edges or sides of the panel. In addition, whether back-lit or side-lit, LCDs often also have a reflective material disposed so as to further facilitate even light distribution from the light sources to the rear of the LCD panel.

The framework of the LCD is composed of a metal such as steel, aluminum, or other structural material and can be screwed, bolted, adhesively bonded, or otherwise securely fastened to the support member, when present. If no support member is present, the framework can be directly attached to the heat dispersion material by an adhesive, mechanical fasteners, or other means known in the art.

The framework can include cross supports spanning the framework where the electronic components can engage the cross support. Additionally, the framework can include a flange to support the heat dispersion material and the electronic components, or alternately the at least one cross member that engages the electronic components. The light sources and heat dispersion material can be positioned substantially within the framework and the framework can include a height

and a width wherein the heat dispersion material substantially spans the height and the width.

Additionally, a plurality of cross supports can span the framework and at least one light source such as a light-emitting diode can engage at least one of the cross supports or any of the remaining framework. While such an arrangement for the framework is preferred, other similar arrangements, such as multiple rows of cross supports, can also be employed within the framework.

When a support member is present, the heat dispersion material is preferably positioned between the light sources and the support member, although this is not required. Either way, the heat dispersion material is in operative thermal contact with the heat generating light sources, by which is meant there is thermal transfer between the light sources and the heat dispersion material. At times, when a support member is present, the support member can be disposed between the heat dispersion material and the light sources, provided the support member is sufficiently thermally conductive to effectively transfer heat from the light sources to the heat dispersion material. Most preferably, however, the heat dispersion material is positioned adjacent to the light sources, such as the light-emitting diodes, and is substantially exposed opposite the light sources. Preferably, when a support member is not present, the heat dispersion material is positioned adjacent to the light sources and is almost entirely exposed opposite the light sources.

In back-lit LCDs, a gap can be present between the heat dispersion material and the PCBs or other structure supporting the light source(s), and/or between the support member and the PCBs or other structure supporting the light source(s); in side-lit displays, the PCBs or other structure supporting the light source(s) are mounted at the edges of the light-spreading optics and a gap can be present between the optics and the heat dispersion material.

In another embodiment, the image display panel includes an image display side engaging a perimeter framework and the heat dispersion material engages the framework opposite to the image display side. The perimeter framework includes a top, a bottom, a first side, and a second side. A plurality of electronic components engages the perimeter frame. The top, bottom, first side, and second side of the perimeter framework define an aperture wherein the heat dispersion material substantially spans the aperture and can engage the top, bottom, first side and second side of the perimeter framework. The heat dispersion material and a plurality of electronic components (especially light sources) can be positioned substantially within the aperture. The framework can include a flange supporting the heat dispersion material and the plurality of electronic components. The image display device can be a liquid crystal display unit, the electronic components can be light sources such as light-emitting diodes, and the heat dispersion material can be comprised of graphite.

In another embodiment the image display device comprises a frame system including a framework operatively engaging an image display panel and a flange positioned opposite the image display panel. A plurality of electronic components engage the flange, while the heat dispersion material is positioned proximate to the plurality of electronic components and opposite the image display panel. The frame system exhibits a support factor of less than about 375 mm-W/m<sup>2</sup> K. A plurality of cross supports can substantially span the framework and engage the flange, wherein each electronic component operatively engages at least one of the cross supports. The heat dispersion material can be positioned between the flange and the plurality of cross supports, while a plurality of fasteners can attach the heat dispersion material and the

plurality of cross supports to the flange. The framework includes a height, a width, and an aperture substantially spanning the height and the width. A plurality of electronic components, such as light sources, engages the framework, can be substantially aligned within the framework, and can be positioned to overlap the aperture.

Where a support member is present, it is generally configured as a sheet, possibly with arms or other extensions, and it is positioned against the framework. The support member, when present, can comprise a metal having a thermal conductivity lower than that previously thought sufficient to provide effective heat dissipation in a display panel, even one also utilizing a graphite or other type of heat dispersion material. For instance, rather than the use of a thick sheet of high thermal conductivity aluminum, a sheet of steel having an in-plane thermal conductivity on the order of less than about 20 W/m<sup>2</sup> K can be employed. Since steel is substantially less expensive than high thermal conductivity aluminum, this results in substantial savings, even if used at the same thickness levels of high thermal conductivity aluminum, i.e., about 2.0 mm. Such a steel sheet would provide the unit with a support factor of 40 mm<sup>2</sup>-W/m<sup>2</sup> K. Alternatively, the support member can be high thermal conductivity aluminum, but employed as a substantially thinner sheet than previously thought feasible, even in a display panel unit also utilizing a graphite or other type of heat dispersion material. For instance, a sheet of high thermal conductivity aluminum of a thickness of 0.5 mm would provide a support factor of about 110 mm<sup>2</sup>-W/m<sup>2</sup> K, resulting in a much lighter weight structure. Of course, when the support member is eliminated altogether, the resulting frame system thus has a support factor of 0 mm<sup>2</sup>-W/m<sup>2</sup> K, and both weight savings and cost savings are substantial.

As noted, the heat dispersion material employed is formed of graphite, and is preferably formed from sheets of compressed particles of exfoliated graphite, commonly known as flexible graphite. Graphite is a crystalline form of carbon comprising atoms covalently bonded in flat layered planes with weaker bonds between the planes. By treating particles of graphite, such as natural graphite flake, with an intercalant of, e.g. a solution of sulfuric and nitric acid, the crystal structure of the graphite reacts to form a compound of graphite and the intercalant. The treated particles of graphite are hereafter referred to as "particles of intercalated graphite." Upon exposure to high temperature, the intercalant within the graphite decomposes and volatilizes, causing the particles of intercalated graphite to expand in dimension as much as about 80 or more times its original volume in an accordion-like fashion in the "c" direction, i.e. in the direction perpendicular to the crystalline planes of the graphite. The exfoliated graphite particles are vermiform in appearance, and are therefore commonly referred to as worms. The worms may be compressed together into flexible sheets that, unlike the original graphite flakes, can be formed and cut into various shapes.

Graphite starting materials suitable for use in the present invention include highly graphitic carbonaceous materials capable of intercalating organic and inorganic acids as well as halogens and then expanding when exposed to heat. These highly graphitic carbonaceous materials most preferably have a degree of graphitization of about 1.0. As used in this disclosure, the term "degree of graphitization" refers to the value g according to the formula:

$$g = \frac{3.45 - d(002)}{0.095}$$

where d(002) is the spacing between the graphitic layers of the carbons in the crystal structure measured in Angstrom

units. The spacing d between graphite layers is measured by standard X-ray diffraction techniques. The positions of diffraction peaks corresponding to the (002), (004) and (006) Miller Indices are measured, and standard least-squares techniques are employed to derive spacing which minimizes the total error for all of these peaks. Examples of highly graphitic carbonaceous materials include natural graphites from various sources, as well as other carbonaceous materials such as graphite prepared by chemical vapor deposition, high temperature pyrolysis of polymers, or crystallization from molten metal solutions and the like. Natural graphite is most preferred.

The graphite starting materials used in the present invention may contain non-graphite components so long as the crystal structure of the starting materials maintains the required degree of graphitization and they are capable of exfoliation. Generally, any carbon-containing material, the crystal structure of which possesses the required degree of graphitization and which can be exfoliated, is suitable for use with the present invention. Such graphite preferably has a purity of at least about eighty weight percent. More preferably, the graphite employed for the present invention will have a purity of at least about 94%. In the most preferred embodiment, the graphite employed will have a purity of at least about 98%.

A common method for manufacturing graphite sheet is described by Shane et al. in U.S. Pat. No. 3,404,061, the disclosure of which is incorporated herein by reference. In the typical practice of the Shane et al. method, natural graphite flakes are intercalated by dispersing the flakes in a solution containing e.g., a mixture of nitric and sulfuric acid, advantageously at a level of about 20 to about 300 parts by weight of intercalant solution per 100 parts by weight of graphite flakes (pph). The intercalation solution contains oxidizing and other intercalating agents known in the art. Examples include those containing oxidizing agents and oxidizing mixtures, such as solutions containing nitric acid, potassium chlorate, chromic acid, potassium permanganate, potassium chromate, potassium dichromate, perchloric acid, and the like, or mixtures, such as for example, concentrated nitric acid and chlorate, chromic acid and phosphoric acid, sulfuric acid and nitric acid, or mixtures of a strong organic acid, e.g. trifluoroacetic acid, and a strong oxidizing agent soluble in the organic acid. Alternatively, an electric potential can be used to bring about oxidation of the graphite. Chemical species that can be introduced into the graphite crystal using electrolytic oxidation include sulfuric acid as well as other acids.

In a preferred embodiment, the intercalating agent is a solution of a mixture of sulfuric acid, or sulfuric acid and phosphoric acid, and an oxidizing agent, i.e. nitric acid, perchloric acid, chromic acid, potassium permanganate, hydrogen peroxide, iodic or periodic acids, or the like. Although less preferred, the intercalation solution may contain metal halides such as ferric chloride, and ferric chloride mixed with sulfuric acid, or a halide, such as bromine as a solution of bromine and sulfuric acid or bromine in an organic solvent.

The quantity of intercalation solution may range from about 20 to about 350 pph and more typically about 40 to about 160 pph. After the flakes are intercalated, any excess solution is drained from the flakes and the flakes are water-washed. Alternatively, the quantity of the intercalation solution may be limited to between about 10 and about 40 pph, which permits the washing step to be eliminated as taught and described in U.S. Pat. No. 4,895,713, the disclosure of which is also herein incorporated by reference.

The particles of graphite flake treated with intercalation solution can optionally be contacted, e.g. by blending, with a reducing organic agent selected from alcohols, sugars, aldehydes and esters which are reactive with the surface film of oxidizing intercalating solution at temperatures in the range of 25° C. and 125° C. Suitable specific organic agents include hexadecanol, octadecanol, 1-octanol, 2-octanol, decylalcohol, 1, 10 decanediol, decylaldehyde, 1-propanol, 1,3 propanediol, ethyleneglycol, polypropylene glycol, dextrose, fructose, lactose, sucrose, potato starch, ethylene glycol monostearate, diethylene glycol dibenzoate, propylene glycol monostearate, glycerol monostearate, dimethyl oxylate, diethyl oxylate, methyl formate, ethyl formate, ascorbic acid and lignin-derived compounds, such as sodium lignosulfate. The amount of organic reducing agent is suitably from about 0.5 to 4% by weight of the particles of graphite flake.

The use of an expansion aid applied prior to, during or immediately after intercalation can also provide improvements. Among these improvements can be reduced exfoliation temperature and increased expanded volume (also referred to as "worm volume"). An expansion aid in this context will advantageously be an organic material sufficiently soluble in the intercalation solution to achieve an improvement in expansion. More narrowly, organic materials of this type that contain carbon, hydrogen and oxygen, preferably exclusively, may be employed. Carboxylic acids have been found especially effective. A suitable carboxylic acid useful as the expansion aid can be selected from aromatic, aliphatic or cycloaliphatic, straight chain or branched chain, saturated and unsaturated monocarboxylic acids, dicarboxylic acids and polycarboxylic acids which have at least 1 carbon atom, and preferably up to about 15 carbon atoms, which is soluble in the intercalation solution in amounts effective to provide a measurable improvement of one or more aspects of exfoliation. Suitable organic solvents can be employed to improve solubility of an organic expansion aid in the intercalation solution.

Representative examples of saturated aliphatic carboxylic acids are acids such as those of the formula  $H(CH_2)_nCOOH$  wherein n is a number of from 0 to about 5, including formic, acetic, propionic, butyric, pentanoic, hexanoic, and the like. In place of the carboxylic acids, the anhydrides or reactive carboxylic acid derivatives such as alkyl esters can also be employed. Representative of alkyl esters are methyl formate and ethyl formate. Sulfuric acid, nitric acid and other known aqueous intercalants have the ability to decompose formic acid, ultimately to water and carbon dioxide. Because of this, formic acid and other sensitive expansion aids are advantageously contacted with the graphite flake prior to immersion of the flake in aqueous intercalant. Representative of dicarboxylic acids are aliphatic dicarboxylic acids having 2-12 carbon atoms, in particular oxalic acid, fumaric acid, malonic acid, maleic acid, succinic acid, glutaric acid, adipic acid, 1,5-pentanedicarboxylic acid, 1,6-hexanedicarboxylic acid, 1,10-decanedicarboxylic acid, cyclohexane-1,4-dicarboxylic acid and aromatic dicarboxylic acids such as phthalic acid or terephthalic acid. Representative of alkyl esters are dimethyl oxylate and diethyl oxylate. Representative of cycloaliphatic acids is cyclohexane carboxylic acid and of aromatic carboxylic acids are benzoic acid, naphthoic acid, anthranilic acid, p-aminobenzoic acid, salicylic acid, o-, m- and p-tolyl acids, methoxy and ethoxybenzoic acids, acetoacetamidobenzoic acids and, acetamidobenzoic acids, phenylacetic acid and naphthoic acids. Representative of hydroxy aromatic acids are hydroxybenzoic acid, 3-hydroxy-1-naphthoic acid, 3-hydroxy-2-naphthoic acid, 4-hydroxy-2-naphthoic acid, 5-hydroxy-1-naphthoic acid, 5-hydroxy-2-naphthoic acid,

6-hydroxy-2-naphthoic acid and 7-hydroxy-2-naphthoic acid. Prominent among the polycarboxylic acids is citric acid.

The intercalation solution will be aqueous and will preferably contain an amount of expansion aid of from about 1 to 10%, the amount being effective to enhance exfoliation. In the embodiment wherein the expansion aid is contacted with the graphite flake prior to or after immersing in the aqueous intercalation solution, the expansion aid can be admixed with the graphite by suitable means, such as a V-blender, typically in an amount of from about 0.2% to about 10% by weight of the graphite flake.

After intercalating the graphite flake, and following the blending of the intercalant coated intercalated graphite flake with the organic reducing agent, the blend is exposed to temperatures in the range of 25° to 125° C. to promote reaction of the reducing agent and intercalant coating. The heating period is up to about 20 hours, with shorter heating periods, e.g., at least about 10 minutes, for higher temperatures in the above-noted range. Times of one half hour or less, e.g., on the order of 10 to 25 minutes, can be employed at the higher temperatures.

The thusly treated particles of graphite are sometimes referred to as "particles of intercalated graphite." Upon exposure to high temperature, e.g. temperatures of at least about 160° C. and especially about 700° C. to 1000° C. and higher, the particles of intercalated graphite expand as much as about 80 to 1000 or more times their original volume in an accordion-like fashion in the c-direction, i.e. in the direction perpendicular to the crystalline planes of the constituent graphite particles. The expanded, i.e. exfoliated, graphite particles are vermiform in appearance, and are therefore commonly referred to as worms. The worms may be compressed together into flexible sheets that, unlike the original graphite flakes, can be formed and cut into various shapes.

Flexible graphite sheet and foil are coherent, with good handling strength, and are suitably compressed, e.g. by roll pressing, to a thickness of about 0.075 mm to 3.75 mm and a typical density of about 0.1 to 1.5 grams per cubic centimeter ( $g/cm^3$ ). From about 1.5-30% by weight of ceramic additives can be blended with the intercalated graphite flakes as described in U.S. Pat. No. 5,902,762 (which is incorporated herein by reference) to provide enhanced resin impregnation in the final flexible graphite product. The additives include ceramic fiber particles having a length of about 0.15 to 1.5 millimeters. The width of the particles is suitably from about 0.04 to 0.004 mm. The ceramic fiber particles are non-reactive and non-adhering to graphite and are stable at temperatures up to about 1100° C., preferably about 1400° C. or higher. Suitable ceramic fiber particles are formed of macerated quartz glass fibers, carbon and graphite fibers, zirconia, boron nitride, silicon carbide and magnesia fibers, naturally occurring mineral fibers such as calcium metasilicate fibers, calcium aluminum silicate fibers, aluminum oxide fibers and the like.

The above described methods for intercalating and exfoliating graphite flake may beneficially be augmented by a pretreatment of the graphite flake at graphitization temperatures, i.e. temperatures in the range of about 3000° C. and above and by the inclusion in the intercalant of a lubricious additive, as described in International Patent Application No. PCT/US02/39749.

The pretreatment, or annealing, of the graphite flake results in significantly increased expansion (i.e., increase in expansion volume of up to 300% or greater) when the flake is subsequently subjected to intercalation and exfoliation. Indeed, desirably, the increase in expansion is at least about 50%, as compared to similar processing without the anneal-

ing step. The temperatures employed for the annealing step should not be significantly below 3000° C., because temperatures even 100° C. lower result in substantially reduced expansion.

The annealing of the present invention is performed for a period of time sufficient to result in a flake having an enhanced degree of expansion upon intercalation and subsequent exfoliation. Typically the time required will be 1 hour or more, preferably 1 to 3 hours and will most advantageously proceed in an inert environment. For maximum beneficial results, the annealed graphite flake will also be subjected to other processes known in the art to enhance the degree expansion—namely intercalation in the presence of an organic reducing agent, an intercalation aid such as an organic acid, and a surfactant wash following intercalation. Moreover, for maximum beneficial results, the intercalation step may be repeated.

The annealing step of the instant invention may be performed in an induction furnace or other such apparatus as is known and appreciated in the art of graphitization; for the temperatures here employed, which are in the range of 3000° C., are at the high end of the range encountered in graphitization processes.

Because it has been observed that the worms produced using graphite subjected to pre-intercalation annealing can sometimes “clump” together, which can negatively impact area weight uniformity, an additive that assists in the formation of “free flowing” worms is highly desirable. The addition of a lubricious additive to the intercalation solution facilitates the more uniform distribution of the worms across the bed of a compression apparatus (such as the bed of a calender station conventionally used for compressing (or “calendering”) graphite worms into flexible graphite sheet. The resulting sheet therefore has higher area weight uniformity and greater tensile strength. The lubricious additive is preferably a long chain hydrocarbon, more preferably a hydrocarbon having at least about 10 carbons. Other organic compounds having long chain hydrocarbon groups, even if other functional groups are present, can also be employed.

More preferably, the lubricious additive is an oil, with a mineral oil being most preferred, especially considering the fact that mineral oils are less prone to rancidity and odors, which can be an important consideration for long term storage. It will be noted that certain of the expansion aids detailed above also meet the definition of a lubricious additive. When these materials are used as the expansion aid, it may not be necessary to include a separate lubricious additive in the intercalant.

The lubricious additive is present in the intercalant in an amount of at least about 1.4 pph, more preferably at least about 1.8 pph. Although the upper limit of the inclusion of lubricious additive is not as critical as the lower limit, there does not appear to be any significant additional advantage to including the lubricious additive at a level of greater than about 4 pph.

The flexible graphite sheet can also, at times, be advantageously treated with resin and the absorbed resin, after curing, enhances the moisture resistance and handling strength, i.e. stiffness, of the flexible graphite sheet as well as “fixing” the morphology of the sheet. Suitable resin content is preferably at least about 5% by weight, more preferably about 10 to 35% by weight, and suitably up to about 60% by weight. Resins found especially useful in the practice of the present invention include acrylic-, epoxy- and phenolic-based resin systems, fluoro-based polymers, or mixtures thereof. Suitable epoxy resin systems include those based on diglycidyl ether of bisphenol A (DGEBA) and other multifunctional resin

systems; phenolic resins that can be employed include resole and novolac phenolics. Optionally, the flexible graphite may be impregnated with fibers and/or salts in addition to the resin or in place of the resin. Additionally, reactive or non-reactive additives may be employed with the resin system to modify properties (such as tack, material flow, hydrophobicity, etc.).

Alternatively, the flexible graphite sheets of the present invention may utilize particles of reground flexible graphite sheets rather than freshly expanded worms, as discussed in International Patent Application No. PCT/US02/16730. The sheets may be newly formed sheet material, recycled sheet material, scrap sheet material, or any other suitable source.

Also the processes of the present invention may use a blend of virgin materials and recycled materials.

The source material for recycled materials may be sheets or trimmed portions of sheets that have been compression molded as described above, or sheets that have been compressed with, for example, pre-calendering rolls, but have not yet been impregnated with resin. Furthermore, the source material may be sheets or trimmed portions of sheets that have been impregnated with resin, but not yet cured, or sheets or trimmed portions of sheets that have been impregnated with resin and cured. The source material may also be recycled flexible graphite proton exchange membrane (PEM) fuel cell components such as flow field plates or electrodes. Each of the various sources of graphite may be used as is or blended with natural graphite flakes.

Once the source material of flexible graphite sheets is available, it can then be comminuted by known processes or devices, such as a jet mill, air mill, blender, etc. to produce particles. Preferably, a majority of the particles have a diameter such that they will pass through 20 U.S. mesh; more preferably a major portion (greater than about 20%, most preferably greater than about 50%) will not pass through 80 U.S. mesh. Most preferably the particles have a particle size of no greater than about 20 mesh. It may be desirable to cool the flexible graphite sheet when it is resin-impregnated as it is being comminuted to avoid heat damage to the resin system during the comminution process.

The size of the comminuted particles may be chosen so as to balance machinability and formability of the graphite article with the thermal characteristics desired. Thus, smaller particles will result in a graphite article which is easier to machine and/or form, whereas larger particles will result in a graphite article having higher anisotropy, and, therefore, greater in-plane electrical and thermal conductivity.

If the source material has been resin impregnated, then preferably the resin is removed from the particles. Details of the resin removal are further described below.

Once the source material is comminuted, and any resin is removed, it is then re-expanded. The re-expansion may occur by using the intercalation and exfoliation process described above and those described in U.S. Pat. No. 3,404,061 to Shane et al. and U.S. Pat. No. 4,895,713 to Greinke et al.

Typically, after intercalation the particles are exfoliated by heating the intercalated particles in a furnace. During this exfoliation step, intercalated natural graphite flakes may be added to the recycled intercalated particles. Preferably, during the re-expansion step the particles are expanded to have a specific volume in the range of at least about 100 cc/g and up to about 350 cc/g or greater. Finally, after the re-expansion step, the re-expanded particles may be compressed into flexible sheets, as hereinafter described.

If the starting material has been impregnated with a resin, the resin should preferably be at least partially removed from the particles. This removal step should occur between the comminuting step and the re-expanding step.

In one embodiment, the removing step includes heating the resin containing regrind particles, such as over an open flame. More specifically, the impregnated resin may be heated to a temperature of at least about 250° C. to effect resin removal. During this heating step care should be taken to avoid flashing of the resin decomposition products; this can be done by careful heating in air or by heating in an inert atmosphere. Preferably, the heating should be in the range of from about 400° C. to about 800° C. for a time in the range of from at least about 10 and up to about 150 minutes or longer.

Additionally, the resin removal step may result in increased tensile strength of the resulting article produced from the molding process as compared to a similar method in which the resin is not removed. The resin removal step may also be advantageous because during the expansion step (i.e., intercalation and exfoliation), when the resin is mixed with the intercalation chemicals, it may in certain instances create toxic byproducts.

Thus, by removing the resin before the expansion step a superior product is obtained such as the increased strength characteristics discussed above. The increased strength characteristics are a result of in part because of increased expansion. With the resin present in the particles, expansion may be restricted.

In addition to strength characteristics and environmental concerns, resin may be removed prior to intercalation in view of concerns about the resin possibly creating a run away exothermic reaction with the acid.

In view of the above, preferably a majority of the resin is removed. More preferably, greater than about 75% of the resin is removed. Most preferably, greater than 99% of the resin is removed.

Once the flexible graphite sheet is comminuted, it is formed into the desired shape and then cured (when resin impregnated) in the preferred embodiment. Alternatively, the sheet can be cured prior to being comminuted, although post-comminution cure is preferred.

Optionally, the flexible graphite sheet used to form the inventive heat dispersion material can be used as a laminate, with or without an adhesive between laminate layers. Non-graphite layers may be included in the laminate stack, although this may necessitate the use of adhesives, which can be disadvantageous, as discussed above. Such non-graphite layers may include metals, plastics or other non-metallics such as fiberglass or ceramics.

As noted above, the thusly-formed sheets of compressed particles of exfoliated graphite are anisotropic in nature; that is, the thermal conductivity of the sheets is greater in the in-plane, or "a" directions, as opposed to the through-sheet, or "c" direction. In this way, the anisotropic nature of the graphite sheet directs the heat along the planar direction of the thermal solution (i.e., in the "a" direction along the graphite sheet). Such a sheet generally has a thermal conductivity in the in-plane direction of at least about 140, more preferably at least about 200, and most preferably at least about 250 W/m° K and in the through-plane direction of no greater than about 12, more preferably no greater than about 10, and most preferably no greater than about 6 W/m° K. Thus, the heat dispersion material has a thermal anisotropic ratio (that is, the ratio of in-plane thermal conductivity to through-plane thermal conductivity) of no less than about 10.

The values of thermal conductivity in the in-plane and through-plane directions of the laminate can be manipulated by altering the directional alignment of the graphene layers of the flexible graphite sheets used to form the thermal solution, including if being used to form a laminate, or by altering the directional alignment of the graphene layers of the laminate

itself after it has been formed. In this way, the in-plane thermal conductivity of the thermal solution is increased, while the through-plane thermal conductivity of the thermal solution is decreased, this resulting in an increase of the thermal anisotropic ratio.

One of the ways this directional alignment of the graphene layers can be achieved is by the application of pressure to the component flexible graphite sheets, either by calendaring the sheets (i.e., through the application of shear force) or by die pressing or reciprocal platen pressing (i.e., through the application of compaction), with calendaring more effective at producing directional alignment. For instance, by calendaring the sheets to a density of 1.7 g/cc, as opposed to 1.1 g/cc, the in-plane thermal conductivity is increased from about 240 W/m° K to about 450 W/m° K or higher, and the through-plane thermal conductivity is decreased proportionally, thus increasing the thermal anisotropic ratio of the individual sheets and, by extension, any laminate formed therefrom.

Alternatively, if a laminate is formed, the directional alignment of the graphene layers which make up the laminate in gross is increased, such as by the application of pressure, resulting in a density greater than the starting density of the component flexible graphite sheets that make up the laminate. Indeed, a final density for the laminated article of at least about 1.4 g/cc, more preferably at least about 1.6 g/cc, and up to about 2.0 g/cc can be obtained in this manner. The pressure can be applied by conventional means, such as by die pressing or calendaring. Pressures of at least about 60 megapascals (MPa) are preferred, with pressures of at least about 550 MPa, and more preferably at least about 700 MPa, needed to achieve densities as high as 2.0 g/cc.

Increasing the directional alignment of the graphene layers can increase the in-plane thermal conductivity of the graphite laminate to conductivities which are equal to or even greater than that of pure copper, while the density remains a fraction of that of pure copper. Additionally, the resulting aligned laminate also exhibits increased strength, as compared to a non-"aligned" laminate.

Surprisingly, by use of such a graphite-based heat dispersion material, the reduction of the support factor for the frame system, indeed the elimination of a support member entirely, can be effected while still providing the necessary mechanical support and effective heat dissipation.

Also included is a method of making a frame system for an image display device. The method includes providing a display panel unit, a heat dispersion material, a framework, and at least one light source, such as a light-emitting diode. The method includes positioning the heat dispersion material so as to be in operative thermal contact with the light source, more preferably so as to be adjacent the light source and between the light source and the framework. The heat dispersion material is preferably substantially open, or exposed, opposite the light source. The light source is positioned to enhance the display of an image on the display panel unit.

It is to be understood that both the foregoing general description and the following detailed description provide embodiments of the invention and are intended to provide an overview or structure of understanding of the nature and character of the invention as it is claimed. The accompanying drawings are included to provide a further understanding of the invention and are incorporated in and constitute a part of the specification. The drawings illustrate various embodiments of the invention and together with the description serve to describe the principles and operations of the invention.

## BRIEF DESCRIPTION OF THE DRAWINGS

FIG. 1 is a side perspective view of components of a back-lit LCD device in accordance with the present invention, including LEDs, reflective material, heat dispersion material and support member.

FIG. 2 is a cross-sectional exploded plan view of the back-lit LCD device of FIG. 1.

FIG. 3 is a cross-sectional plan view of the back-lit LCD device of FIG. 1.

FIG. 4 is a side perspective view of components of a side-lit LCD device in accordance with the present invention, including PCB-mounted LEDs, reflective material, heat dispersion material, light-spreading optics and support member.

FIG. 5 is a cross-sectional exploded plan view of the side-lit LCD device of FIG. 4.

FIG. 6 is a cross-sectional plan view of the side-lit LCD device of FIG. 4.

FIG. 7 is a cross-sectional side plan view of an alternative embodiment of a side-lit LCD device in accordance with the present invention.

FIG. 8 is a cross-sectional side plan view of another alternative embodiment of a side-lit LCD device in accordance with the present invention.

FIG. 9 is a front view of an image display device made in accordance with the current disclosure shown within a casing and having an image displayed thereon.

FIG. 10 is a side exploded perspective view showing an embodiment of an image display device made in accordance with the present invention.

FIG. 11 is a rear view of a framework made in accordance with the present invention.

## DETAILED DESCRIPTION OF THE PREFERRED EMBODIMENTS

Referring generally now to FIGS. 1-3, a back-lit LCD image display device is shown and generally designated by the numeral 10. Device 10 comprises a series of light sources, such as LEDs 20 mounted so as to be directed to an image display panel (not shown). Device 10 further comprises heat dispersion material 30, formed of sheets of compressed particles of exfoliated graphite. Heat dispersion material 30 is in operative thermal contact with LEDs 20, such that heat generated by LEDs 20 is transferred to heat dispersion material 30. In addition, LCD device 10 can also comprise a support member 40, such that the support factor of device 10 is less than about 375 mm-W/m<sup>2</sup> K. More preferably, support member 40 provides a support factor to device 10 of less than about 150 mm-W/m<sup>2</sup> K. As discussed above, however, in the most preferred embodiment of the present invention, the support factor of device 10 is 0 mm-W/m<sup>2</sup> K, meaning there is no support member 40 in LCD device 10. A reflective material 50 can be interposed about LEDs 20 to facilitate even distribution of light from LEDs 20.

Referring now to FIGS. 4-6, a side-lit LCD device, denoted 100, is shown. Device 100 comprises a series of light sources, such as LEDs 120 mounted along at least a portion of the perimeter of device 100; light-spreading optics, such as light guide 170 assists in directing light from LEDs 120 to an image display panel (not shown). Device 100 further comprises heat dispersion material 130, formed of one or more sheets of compressed particles of exfoliated graphite. Heat dispersion material 130 is in operative thermal contact with LEDs 120, such that heat generated by LEDs 120 is transferred to heat dispersion material 130. However, because of the arrangement of LEDs 120 about the perimeter of LCD device

100, operative thermal contact between heat dispersion material 130 and LEDs 120 is effected via thermal connectors 135.

Thermal connectors 135 can be any material capable of making thermal contact between LEDs 120 and heat dispersion material 130. Preferably, thermal connectors 135 are also formed of compressed particles of exfoliated graphite, as is heat dispersion material 130. Indeed, in an especially preferred embodiment, heat dispersion material 130 is formed so as to have thermal connectors 135 formed integrally therein (as illustrated in FIG. 7). In other words, heat dispersion material 130 can have sections bent at an approximately 90° angle to thus form thermal connectors 135.

In an alternative embodiment, the PCBs 160 on which LEDs 120 are mounted can be extended and bent at an approximately 90° angle to make the thermal connection between LEDs 120 and heat dispersion material 130. As noted above, the PCBs 160 on which LEDs 120 are commonly mounted are typically metal core PCBs; thus, the metal core from such PCBs 160 can be extended and bent at the appropriate angle to provide the thermal connection between LEDs 120 and heat dispersion material 130, as shown in FIG. 8. Alternatively, PCBs 160 can be formed of so-called flex-circuit PCBs with LEDs directly mounted to them, with PCBs 160 bonded or otherwise attached directly to heat dispersion material 130. The flex-circuit material from which PCBs 160 are formed could be polyimide, polyester, liquid crystal polymer (LCP), etc. and may have a plurality of thermally conductive vias running through the thin flex-circuit PCBs 160 to heat dispersion material 130, to keep thermal resistance between the two as low as feasible. An adhesive may be used to bond PCBs 160 to heat dispersion material 130.

Side-lit LCD device 100 can also comprise a support member 140, such that the support factor of device 100 is less than about 375 mm-W/m<sup>2</sup> K. More preferably, support member 140 provides a support factor to device 100 of less than about 150 mm-W/m<sup>2</sup> K. In the most preferred embodiment of the present invention, the support factor of device 100 is 0 mm-W/m<sup>2</sup> K, meaning LCD device 100 contains no support member 140. Moreover, a reflective material 150 can be interposed about LEDs 120 or behind light guide 170 to facilitate even distribution of light from LEDs 120.

Referring now to FIGS. 9-11 (directed to a back-lit LCD 10, although the concepts can also be applied to side-lit LCDs), back-lit image display device 10 comprises an image display panel 12 for displaying an image 14, a frame system 18, and heat dispersion material 30 operatively engaging the frame system 18 and positioned opposite the image display panel 12. The frame system 18 can include a framework 17, which can be called a perimeter framework 17, supporting the image display panel 12 and a plurality of LEDs 20 supported by the framework 17. The framework 17 includes a height 22, a width 24 and an aperture 26 substantially spanning the height 22 and width 24. The heat dispersion material 30 can substantially span the height 22 and width 24 of the framework 17. Alternatively, the heat dispersion material 30 can comprise multiple pieces of heat dispersion material collectively substantially spanning the height 22 and width 24 of the framework 17 in sum.

LEDs can be substantially aligned within the framework 17, and can overlap a portion of the aperture 26. This alignment facilitates the heat dispersion material 30 to dissipate heat generated by LEDs 20. LEDs 20 can also be positioned within the aperture 26 of the framework 17.

In a preferred embodiment the heat dispersion material 30 comprises compressed particles of exfoliated graphite while the framework 17 is comprised of steel.

The LCD image display panel **12** can include an image display side **13** on which the image **14** is displayed. The image display side **13** can be seen through the casing **11** of the image display device **10** as best illustrated in FIG. 9.

The heat dispersion material **30** can also include an adhesive and/or thermal interface material (not shown) on the surface facing LEDs **20**. This adhesive, for example a pressure sensitive adhesive, can facilitate good thermal contact between LEDs **20** and heat dispersion material **30** to enhance the heat dissipation within the device **10**.

Additionally, as illustrated in FIG. 10, cross supports **34** can be attached to framework **17**. Cross supports **34** can be used to strengthen and stabilize framework **17** and overall image display device **10**. Cross supports **34** preferably support LEDs **20** and attach LEDs **20** to the framework **17**, whether or not LEDs **20** are mounted to PCBs. Multiple cross supports **34** could be used to add further rigidity to framework **17** and LCD device **10**. The engagement between cross supports **34** and framework **17** could include mechanical fasteners such as screws, bolts, rivets, clips, and the like, as known in the art (not shown).

Traversing members **36** can also be used to add further rigidity to the framework **17**. Traversing members **36** preferably span framework **17** and can engage a flange **28** on framework **17**. Traversing members **36** can be comprised of, individually or in combination, steel, aluminum, and plastic. Traversing members **36** could be used to engage casing **11** and secure casing **11** as part of display device **10**. Traversing members **36** could support a second plurality of electronic components, such as printed circuit boards, to provide controls for LCD device **10**. Traversing members **36** could completely cross framework **17**, as seen in FIG. 10, or alternately extend partially across aperture **26**.

Framework **17** could be manufactured as a single extruded piece and bent, or folded, into shape. Alternately, framework **17** could be manufactured in multiple pieces and mechanically assembled, such as by rivets, welds, Tox-Lok® mechanical attachment or the like, thereby reducing the need to stamp framework **17** from a single sheet of material.

Thus, by the practice of the present invention, a display panel, such as, a liquid crystal display, and the like, can be constructed with a reduced need for a support member, indeed, without the need for a support member at all, resulting in substantial savings in both weight and cost for the display panel while maintaining or increasing heat transfer away from heat generating elements within the image display device.

All cited patents and publications referred to in this application are incorporated by reference.

The invention thus being described, it will obvious that it may be varied in many ways. Such variations are not to be regarded as a departure from the spirit and scope of the present invention and all such modifications as would be obvious to one skilled in the art are intended to be included in the scope of the following claims.

What is claimed is:

1. A frame system for an image display device which comprises a display panel and a plurality of heat sources, the frame system comprising:

- (i) a framework operatively engaging an image display panel, the framework also having the heat sources engaged therewith, wherein the framework comprises a metal support member to which is attached the display panel unit and electronic components
- (ii) heat dispersion material comprising at least one sheet of compressed particles of exfoliated graphite having an in-plane thermal conductivity of at least about 250

W/m-K and a thermal anisotropic ratio of no less than about 10, the heat dispersion material operatively engaging the framework in operative thermal contact with the heat sources; and

wherein the frame system exhibits a support factor of less than about 150 mm-W/m-K, the support factor determined by multiplying the thickness of the support member by its in-plane thermal conductivity and further wherein the image display device exhibits improved temperature uniformity as compared to an image display device having a frame system which exhibits a support factor of less than about 150 mm-W/m-K but does not include a heat dispersion material having an in-plane thermal conductivity of at least about 250 W/m-K positioned proximate to the image display panel.

2. The frame system of claim 1, wherein the heat sources comprise light emitting diodes, cold cathode fluorescent lamps, flat fluorescent lamps, or combinations thereof.

3. The frame system of claim 1, which comprises a side-lit liquid crystal display device.

4. The frame system of claim 3, which further comprises at least one thermal connector between the heat sources and the heat dispersion material.

5. The frame system of claim 4, wherein the at least one thermal connector comprises the printed circuit board on which light emitting diodes are mounted.

6. The frame system of claim 1, which further comprises a reflective material interposed about the heat sources to facilitate even distribution of light therefrom.

7. A frame system for an image display device which comprises a plurality of electronic components, the frame system comprising:

- (i) a perimeter framework operatively engaging an image display panel opposite the image display side, the perimeter framework including a top, bottom, first side, and second side, the framework comprising a support member to which is attached the display panel unit and electronic components; and
- (ii) a plurality of electronic components operatively engaging the framework;

heat dispersion material comprising at least one sheet of compressed particles of exfoliated graphite having an in-plane thermal conductivity of at least about 250 W/m-K and a thermal anisotropic ratio of no less than about 10, the heat dispersion material operatively engaging the framework and in operative thermal contact with the electronic components; and

wherein the framework exhibits a support factor of less than about 150 mm-W/m-K, the support factor determined by multiplying the thickness of the support member by its in-plane thermal conductivity and further wherein the image display device exhibits improved temperature uniformity as compared to an image display device having a frame system which exhibits a support factor of less than about 150 mm-W/m-K but does not include a heat dispersion material having an in-plane thermal conductivity of at least about 250 W/m-K positioned proximate to the image display panel.

8. The frame system of claim 7, wherein the top, bottom first side and second side of the framework define an aperture and the plurality of electronic components are positioned substantially within the aperture.

9. The frame system of claim 8, wherein the heat dispersion material substantially spans the aperture.

10. The frame system of claim 9, wherein the heat dispersion material operatively engages the top, bottom, first side and second side of the framework.

11. The frame system of claim 7, wherein the image display panel is a liquid crystal display panel and the electronic components include light-emitting diodes.

12. The frame system of claim 7, wherein the electronic components comprise light emitting diodes, cold cathode fluorescent lamps, flat fluorescent lamps, or combinations thereof.

13. The frame system of claim 7, which comprises a side-lit liquid crystal display device.

14. The frame system of claim 13, which further comprises at least one thermal connector between the heat sources and the heat dispersion material.

15. The frame system of claim 14, wherein the at least one thermal connector comprises the printed circuit board on which light emitting diodes are mounted.

16. The frame system of claim 7, which further comprises a reflective material can be interposed about the heat sources to facilitate even distribution of light therefrom.

\* \* \* \* \*

专利名称(译)	用于液晶显示装置的优化框架系统		
公开(公告)号	<a href="#">US9104058</a>	公开(公告)日	2015-08-11
申请号	US11/223804	申请日	2005-09-09
[标]申请(专利权)人(译)	植物性杂质GARYD VARELA WILLIAM		
申请(专利权)人(译)	植物性杂质GARYD VARELA WILLIAM		
当前申请(专利权)人(译)	GRAFTECH INTERNATIONAL HOLDINGS INC.		
[标]发明人	SHIVES GARY D VARELA WILLIAM		
发明人	SHIVES, GARY D. VARELA, WILLIAM		
IPC分类号	G02F1/1333 H05K7/20 G02F1/1335		
CPC分类号	G02F1/133385 G02F1/133603 H05K7/20963 G02F2001/133628 G02F1/133308 G02F1/133382		
其他公开文献	US20060292461A1		
外部链接	<a href="#">Espacenet</a> <a href="#">USPTO</a>		

摘要(译)

一种图像显示装置，包括图像显示板，框架系统，包括可操作地接合图像显示板的框架和可操作地接合框架的多个电子元件，可操作地接合框架并与电子元件可操作地接触的热分散材料，其中框架系统的支撑系数小于约 $375 \text{ mm-W} / \text{m}^{\circ}\text{K}$ 。

