



(19) **United States**

(12) **Patent Application Publication** (10) **Pub. No.: US 2007/0001998 A1**  
**Smith et al.** (43) **Pub. Date: Jan. 4, 2007**

(54) **FLAT PANEL DISPLAY DEVICE,  
CONTROLLER, AND METHOD FOR  
DISPLAYING IMAGES**

**Publication Classification**

(51) **Int. Cl.**  
**G09G 3/36** (2006.01)  
(52) **U.S. Cl.** ..... **345/102**

(76) Inventors: **Sterling Smith**, Hsin-Chu Hsien (TW);  
**Chih-Tien Chang**, Hsin-Chu Hsien  
(TW)

(57) **ABSTRACT**

Correspondence Address:  
**NORTH AMERICA INTELLECTUAL  
PROPERTY CORPORATION  
P.O. BOX 506  
MERRIFIELD, VA 22116 (US)**

A flat panel display device, LCD controller and associated method is provided. The flat panel display device includes a display panel, a lamp for providing a backlight source for the display panel, a power transformation module for providing a power source for the lamp, a non-volatile storage unit for storing program code, and a display controller. The display controller includes an image processing module for processing image data and outputting processed results to the display panel, and a digital pulse width modulation module for adjusting on and off time of the power transformation module according to a synchronization signal.

(21) Appl. No.: **11/423,149**

(22) Filed: **Jun. 9, 2006**

**Related U.S. Application Data**

(60) Provisional application No. 60/694,687, filed on Jun. 29, 2005. Provisional application No. 60/596,141, filed on Sep. 2, 2005.

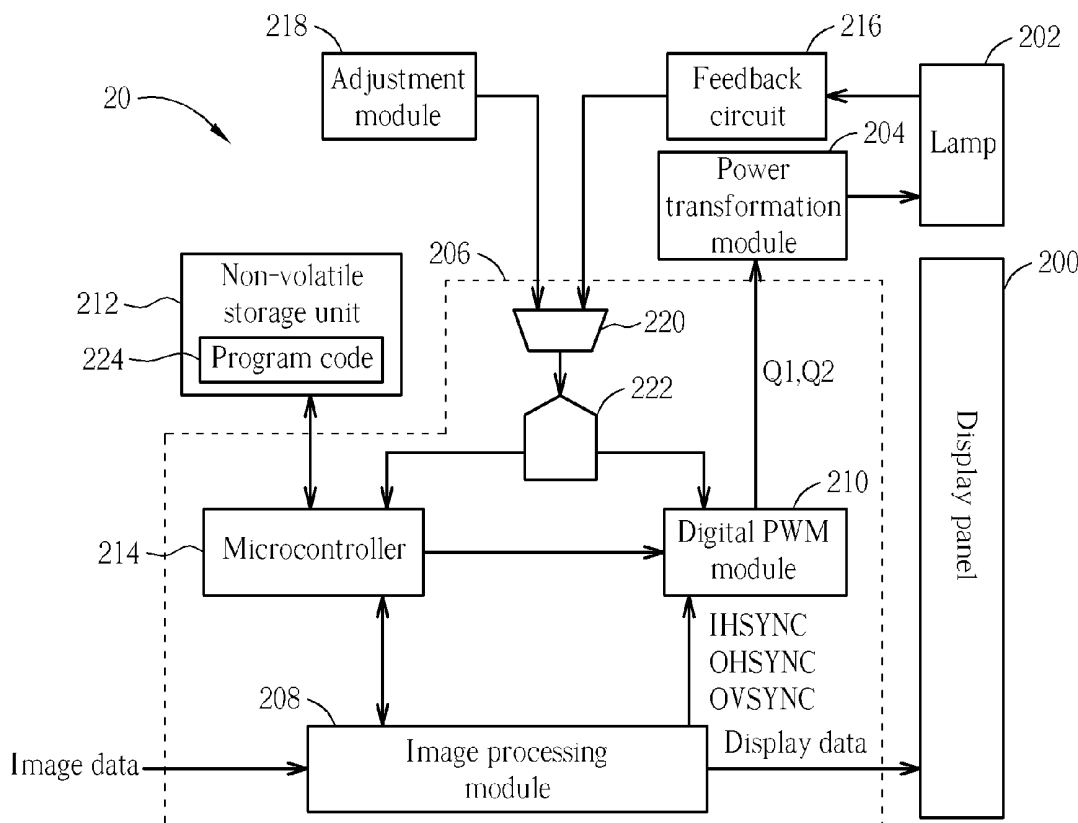

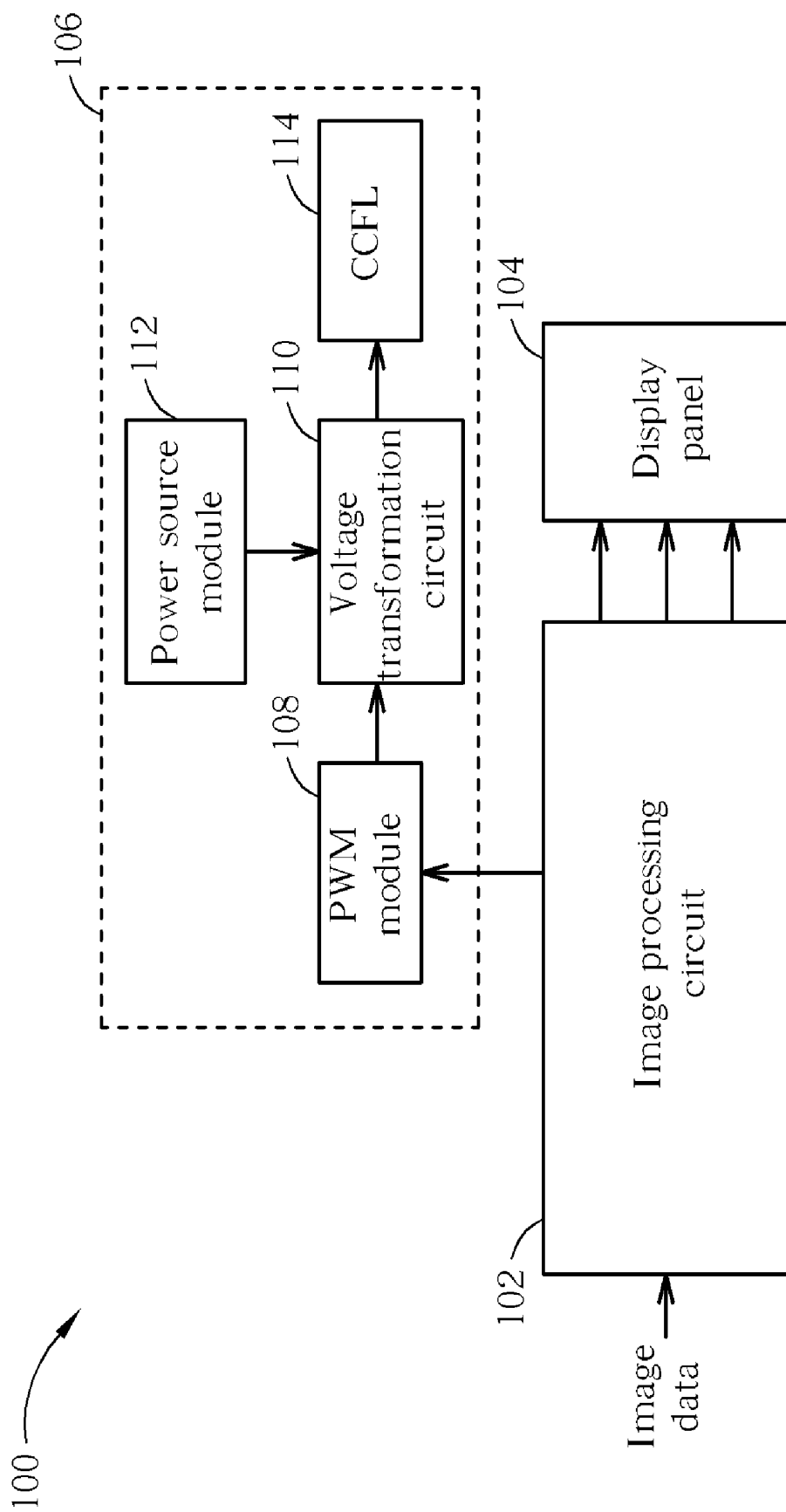

Fig. 1 Prior art

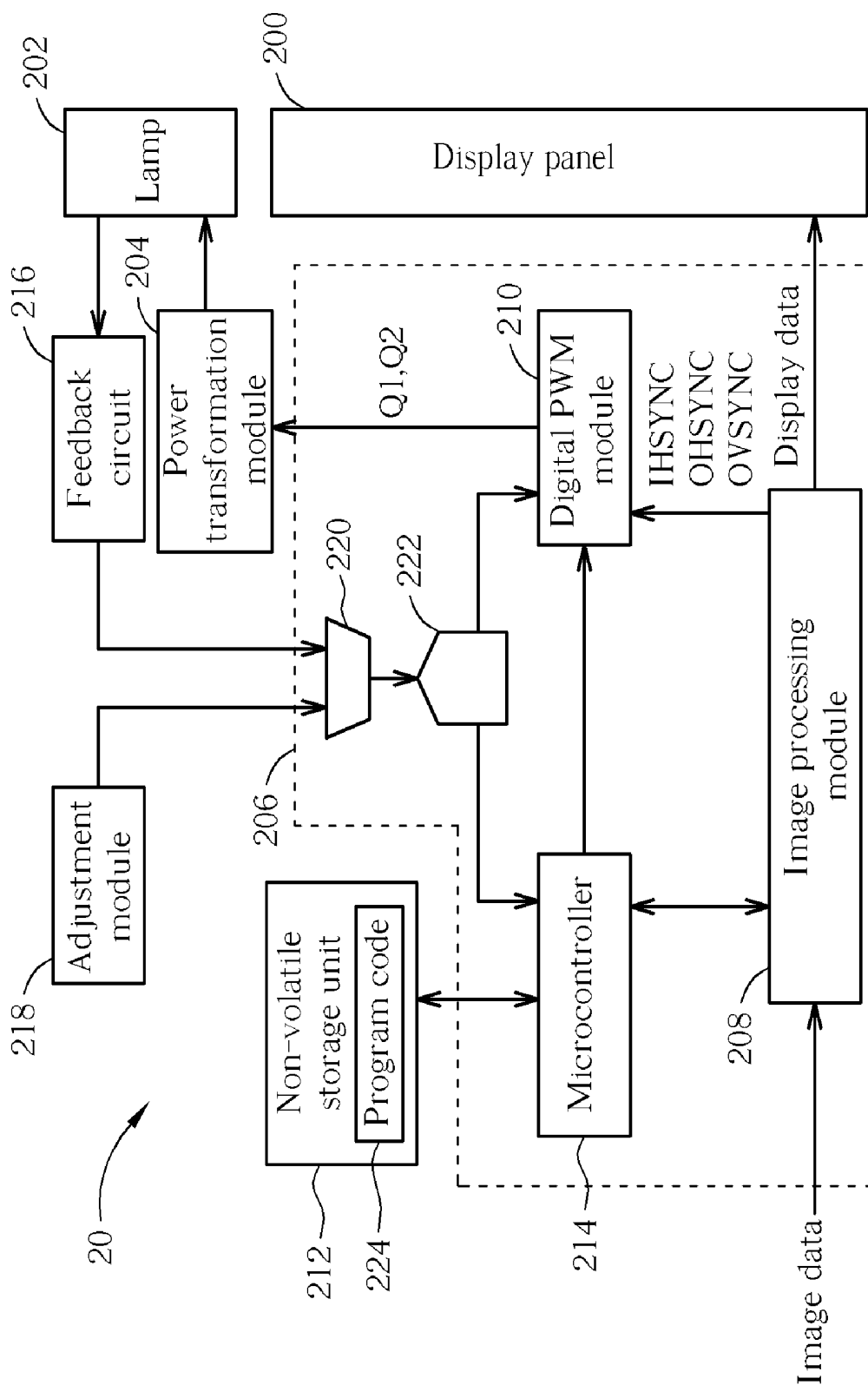

Fig. 2

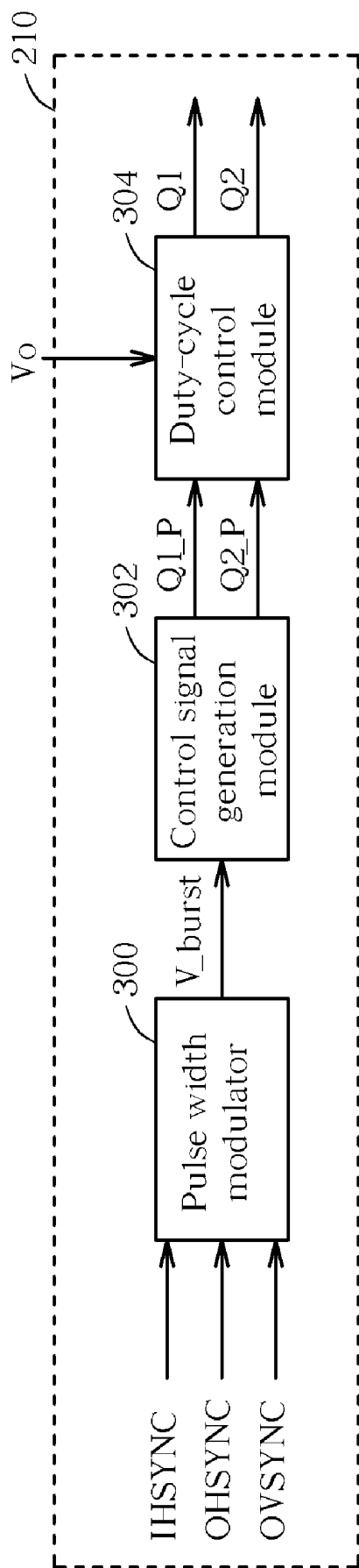

Fig. 3

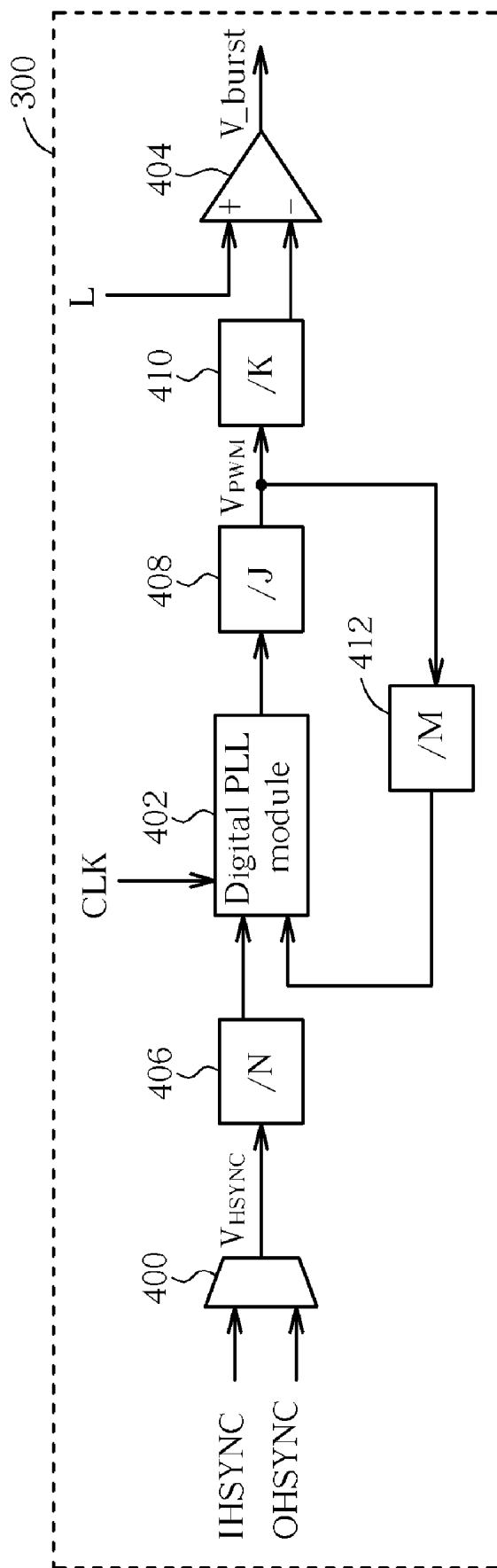

Fig. 4

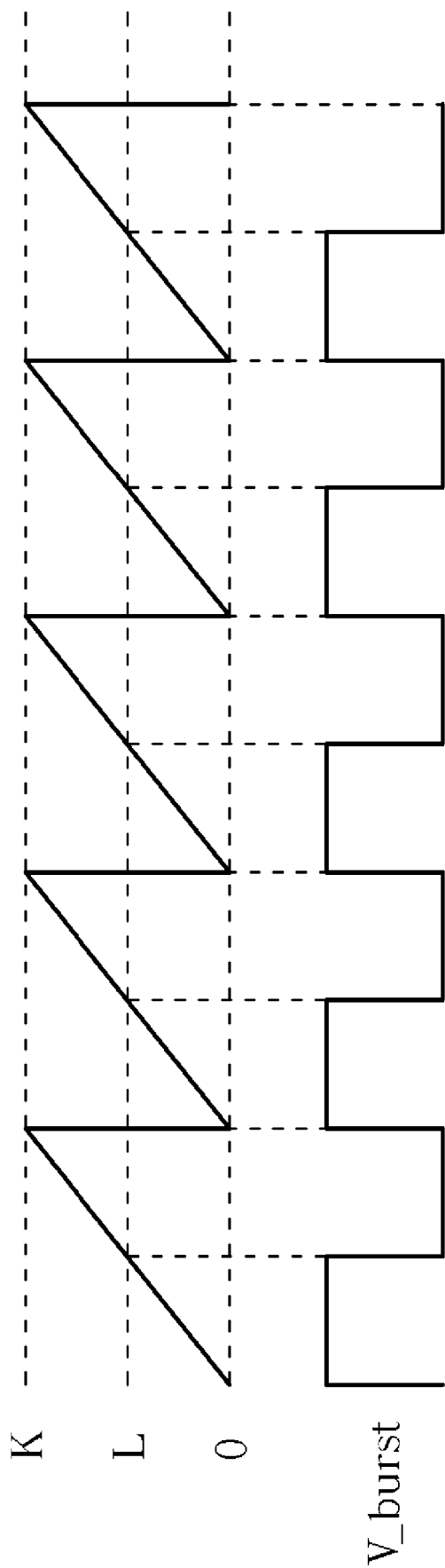

Fig. 5

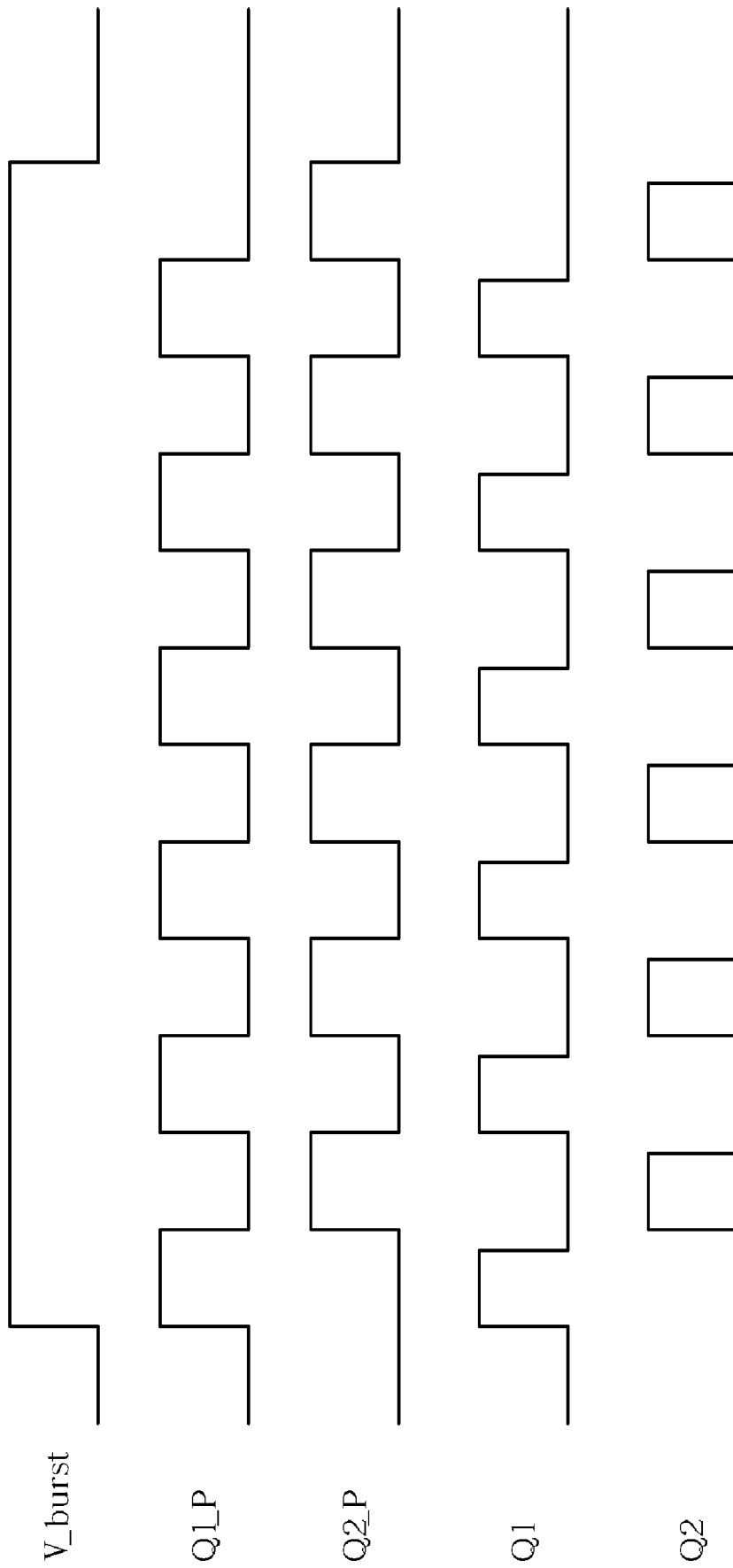

Fig. 6

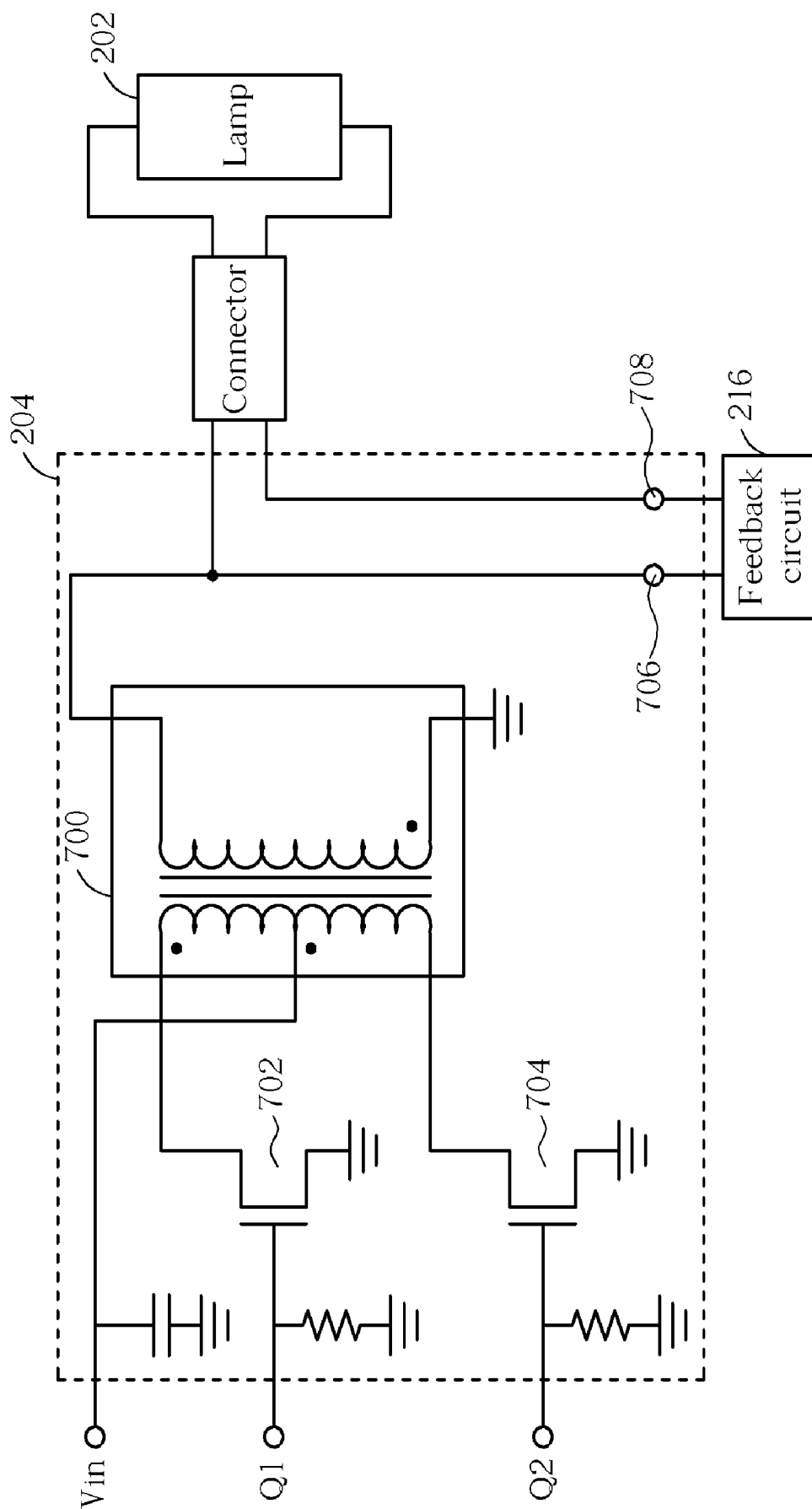

Fig. 7

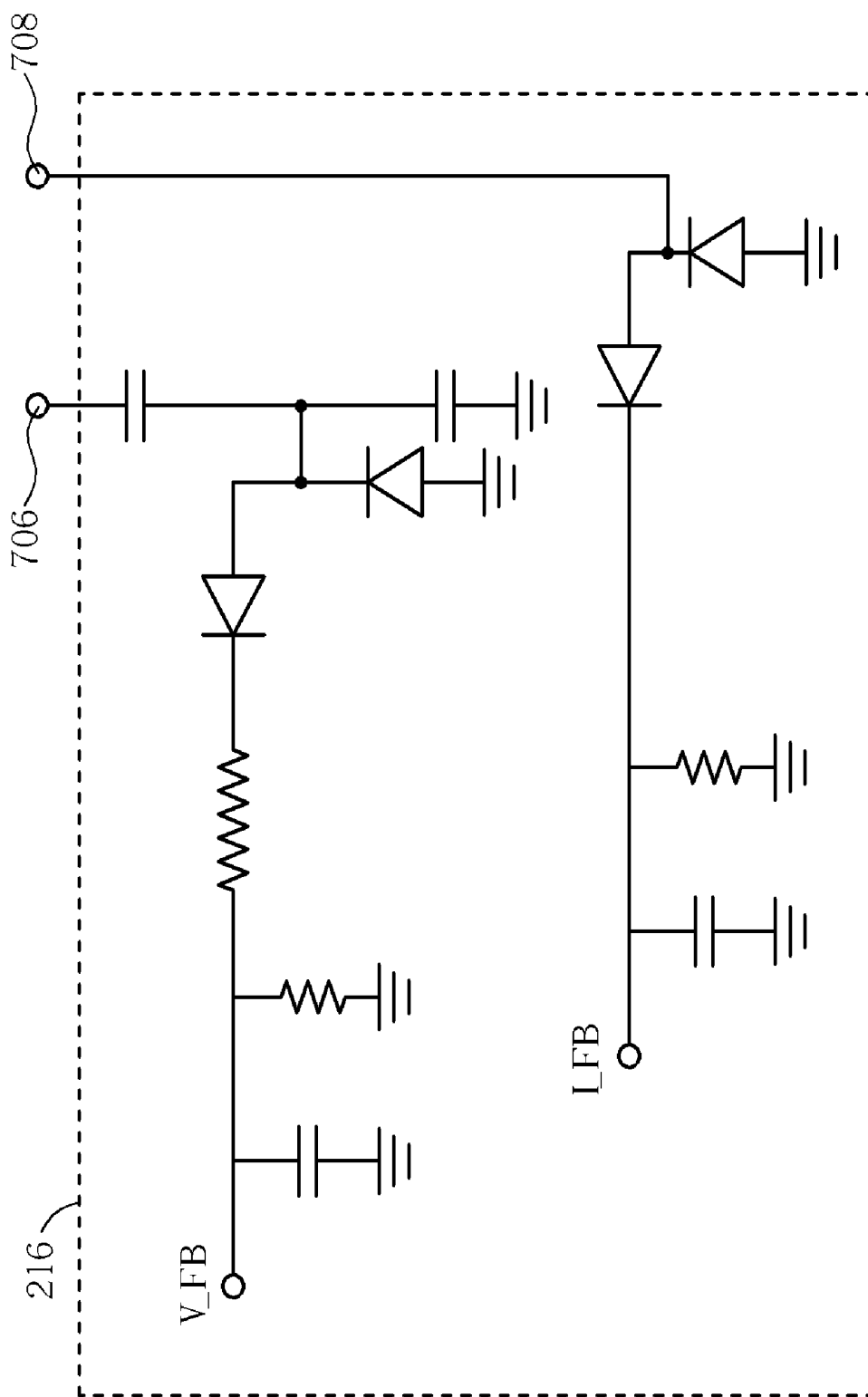

Fig. 8

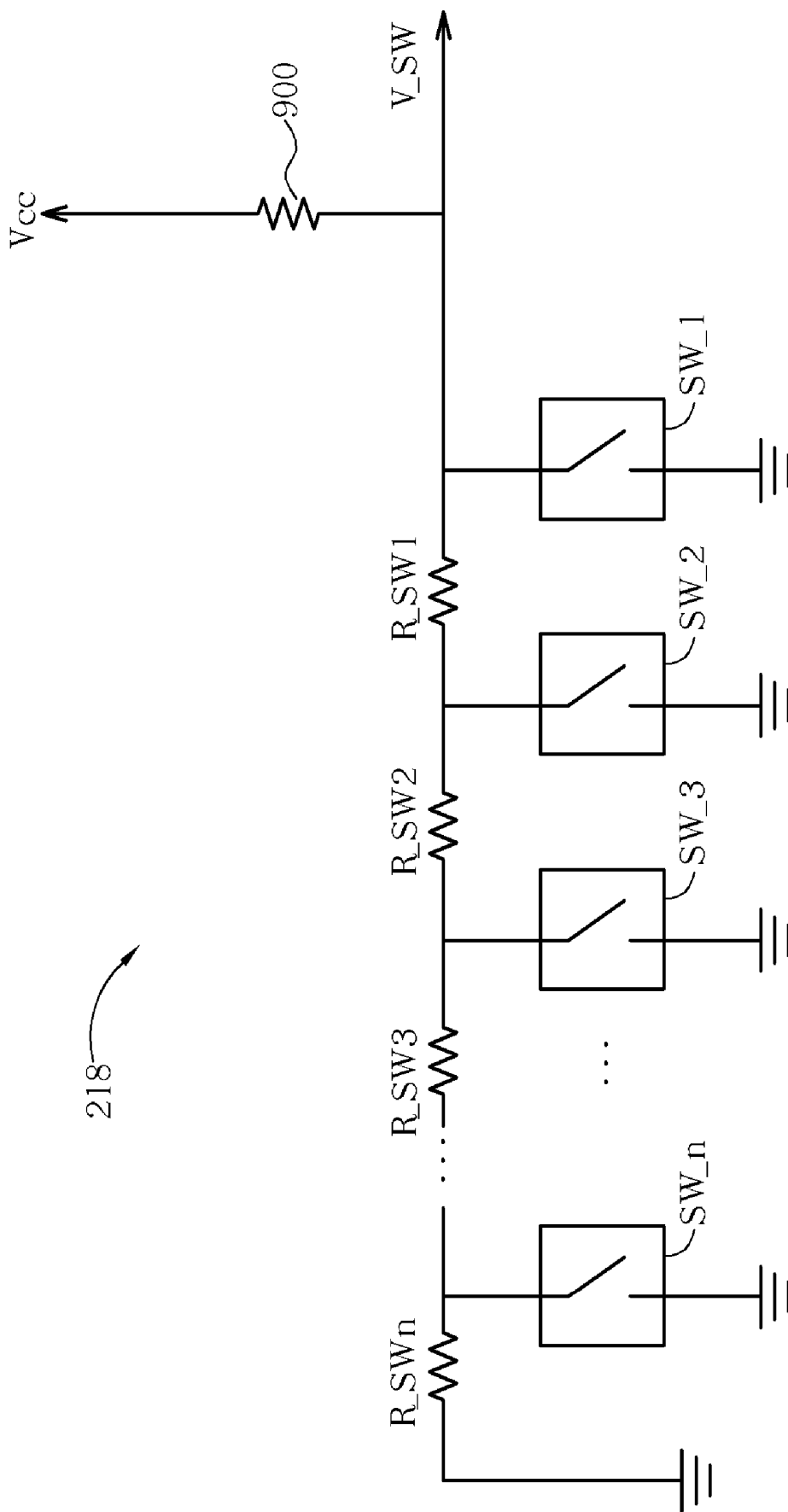

Fig. 9

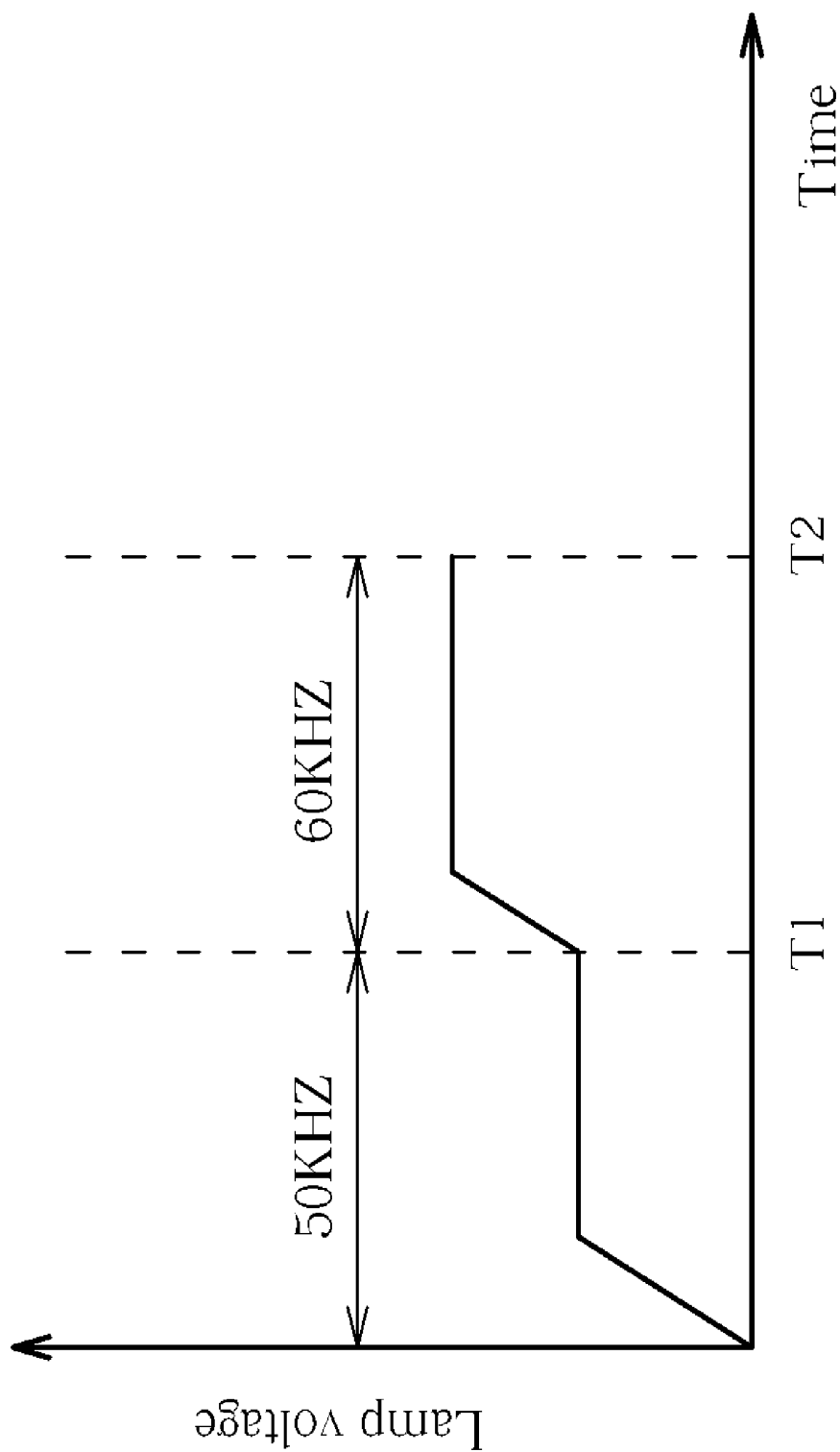

Fig. 10

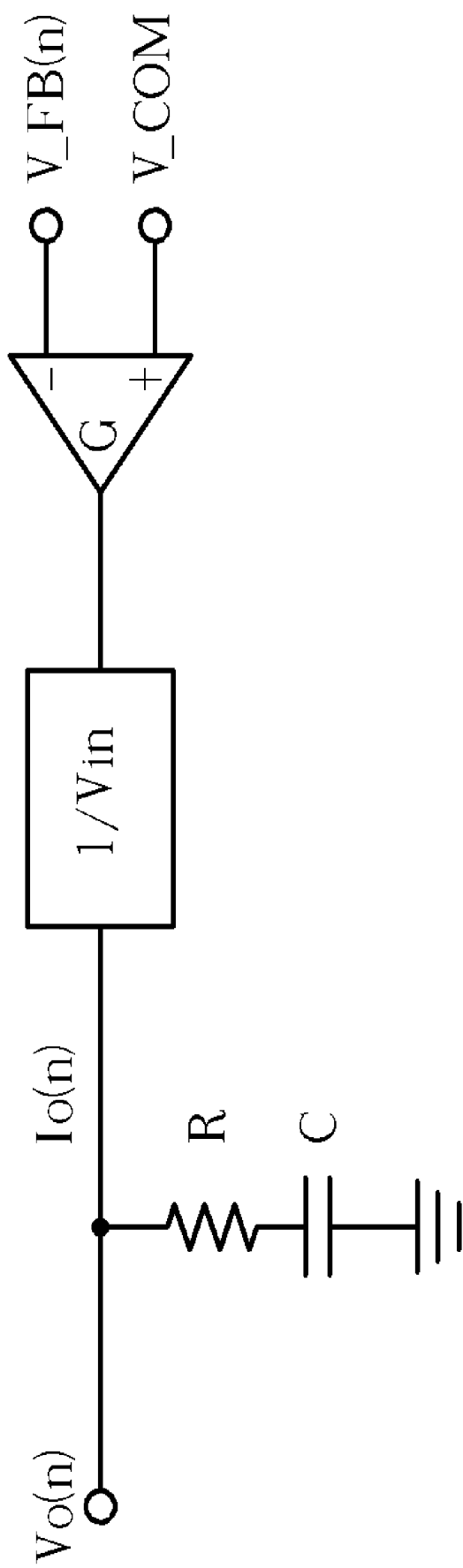

Fig. 11

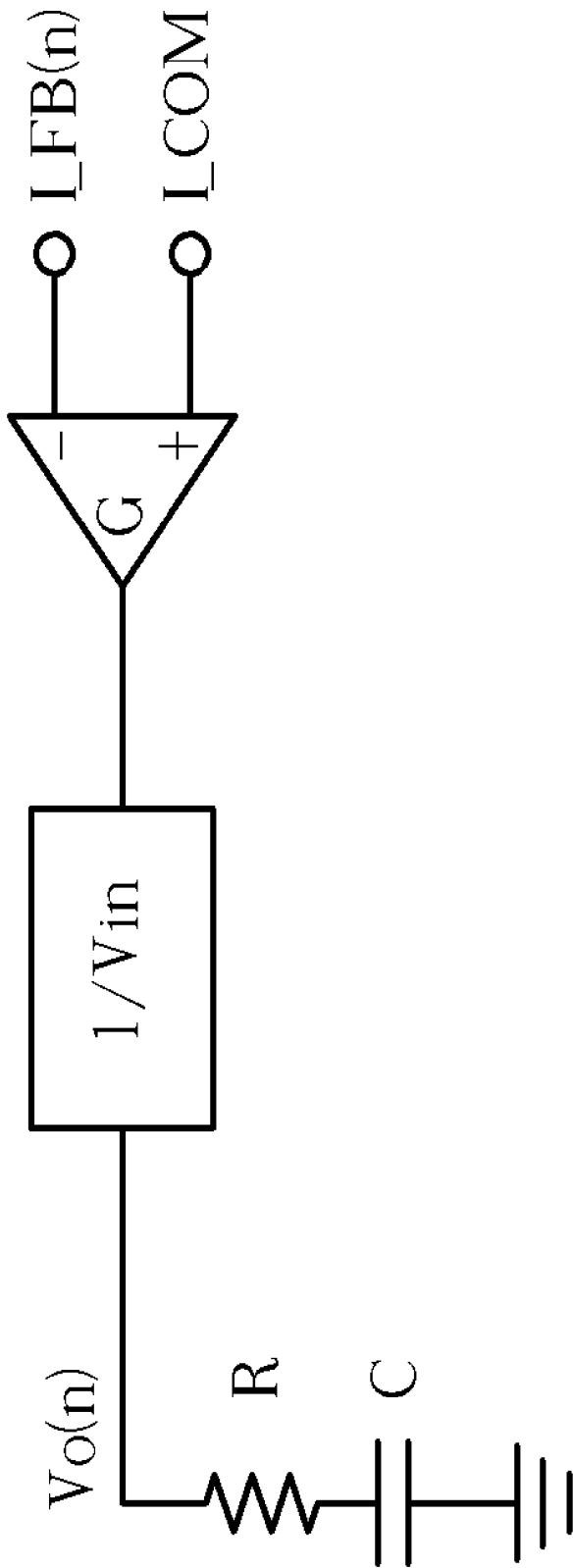

Fig. 12



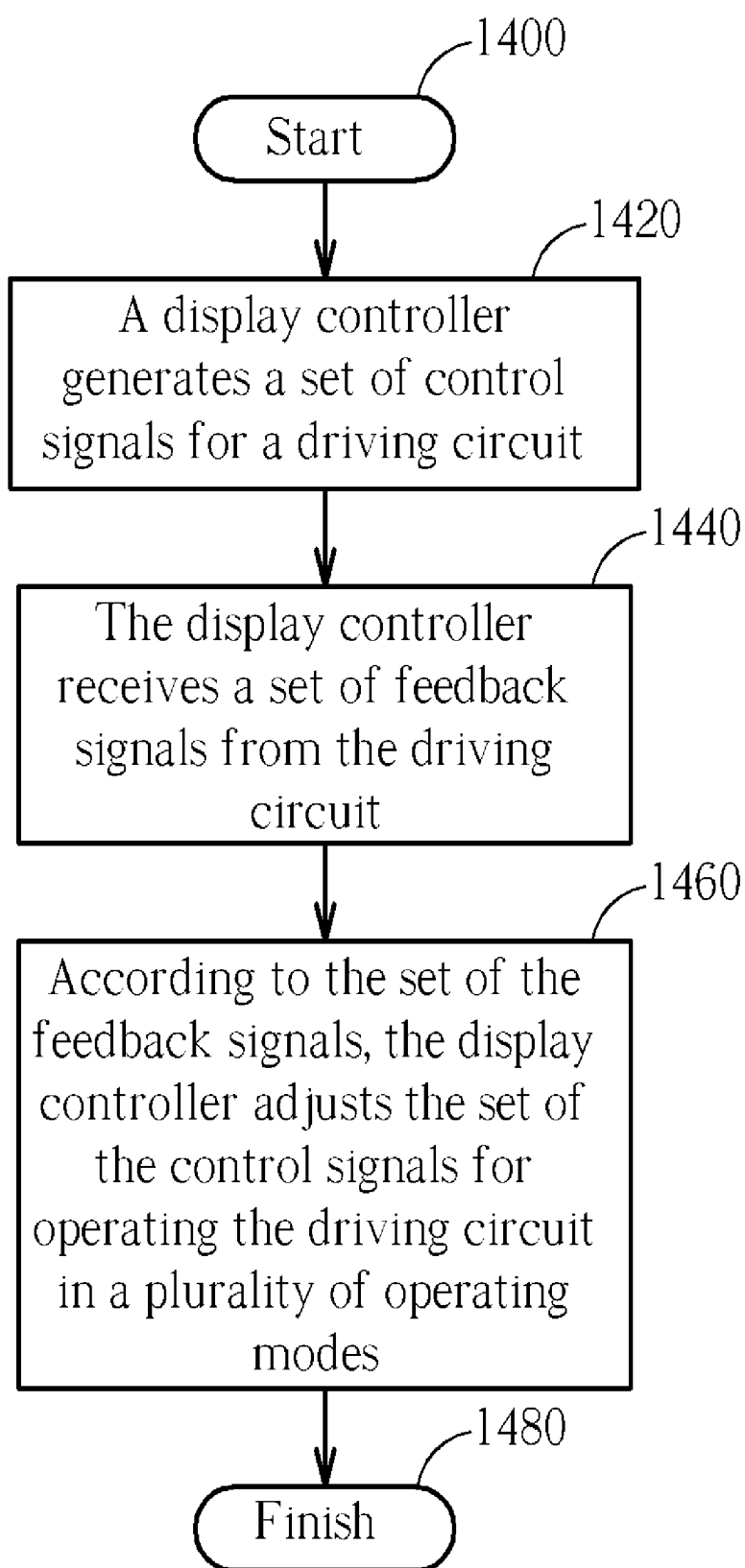

Fig. 14

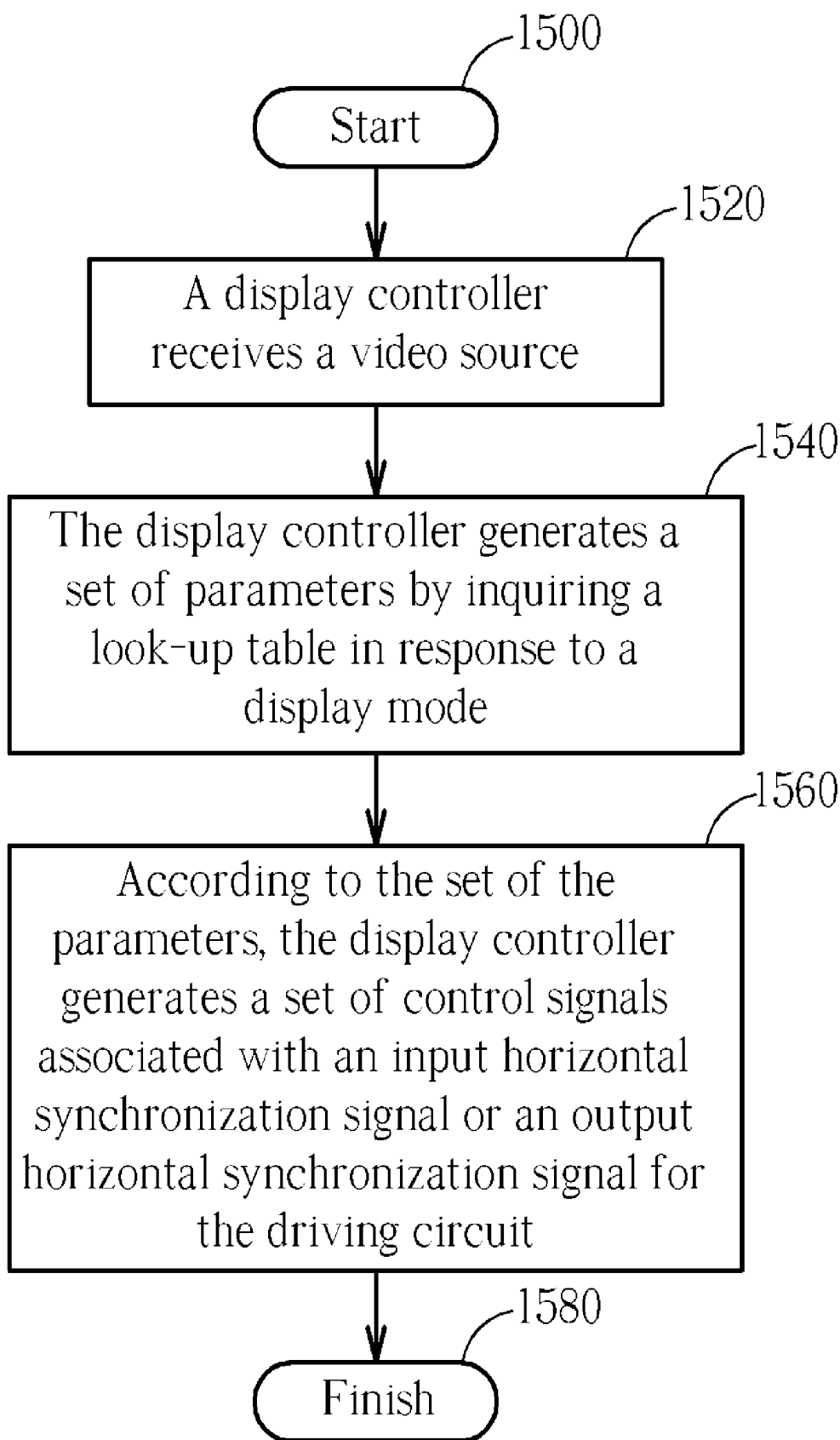

Fig. 15

**FLAT PANEL DISPLAY DEVICE, CONTROLLER,  
AND METHOD FOR DISPLAYING IMAGES**CROSS REFERENCE TO RELATED  
APPLICATIONS

[0001] This application claims the benefit of U.S. Provisional Application No. 60/694,687 and 60/596,141, filed Jun. 29, 2005 and Sep. 2, 2005 respectively, and included herein by reference.

## BACKGROUND OF THE INVENTION

[0002] 1. Field of the Invention

[0003] The present invention relates to a flat panel display device, controller, and method for displaying images, and more particularly, to a flat panel display device, controller, and method for enhancing display quality by associating a frequency of a lamp with a display frequency.

[0004] 2. Description of the Prior Art

[0005] Liquid crystal display (LCD) monitors can be classified into reflective, transmissive, and transreflective LCD monitors. A reflective LCD monitor displays images with an external light source, which penetrates a display panel and is reflected by an internal reflector therein. A transmissive LCD monitor comprises a backlight source behind liquid crystal units, which emits light and penetrates liquid crystal units. A transreflective LCD monitor is a combination of the reflective LCD monitor and the transmissive LCD monitor.

[0006] In the transmissive LCD monitor, one or multiple cold cathode fluorescent lamps (CCFLs) are used as backlight sources. To emit light, the CCFL is driven by a high voltage source. Then, the CCFL excites mercury vapor therein to a high energy level by discharging the electricity. The excited mercury vapor returns to its initial energy state while the extra energy becomes ultraviolet. Finally, a phosphorescence material, spread on the inner surface of the CCFL, transforms ultraviolet into visible light.

[0007] FIG. 1 illustrates a block diagram of a prior art transmissive LCD monitor 100. The LCD monitor 100 includes an image processing circuit 102, a display panel 104, and a backlight module 106. The image processing circuit 102 controls R, G, and B (red, green, and blue) components for each pixel on the display panel 104 to display different color and contrast. The backlight module 106 includes a pulse width modulation (PWM) module 108, a voltage transformation circuit 110, a power source module 112, and a CCFL 114 to provide a light source for displaying images. To drive the CCFL 114, the voltage transformation circuit 110 transforms low-voltage DC power provided by the power source module 112 into high-voltage AC power with high-frequency. The PWM module 108 controls the AC power provided by the voltage transformation circuit 110 to adjust luminance of the CCFL 114. The PWM module 108 controls luminance of the CCFL 114 by adjusting on and off time of the CCFL 114 periodically. Therefore, the PWM module 108 provides a wider dimming range.

[0008] Conventionally, the image processing circuit 102 generates control signals through digital signal processing procedures, while the PWM module 108 is implemented by additional analog circuits, so that the image processing

circuit 102 and the PWM module 108, causing ripples on the display panel 104, and decreasing quality.

## SUMMARY OF THE INVENTION

[0009] It is therefore a primary objective of the claimed invention to provide a flat panel display device, controller, and method for displaying images.

[0010] The present invention discloses a flat panel display device, which comprises a display panel, a lamp for providing a backlight source for the display panel, a power transformation module for providing a power source for the lamp, a non-volatile storage unit for storing program code, and a display controller. The display controller comprises an image processing module for processing image data and outputting processed results to the display panel, and a digital pulse width modulation module for adjusting on and off time of the power transformation module according to a horizontal synchronization signal.

[0011] The present invention further discloses a display controller, comprising an image processing module for processing image data, and a digital pulse width modulation module coupled to the image processing module and an external application circuit, for generating a set of control signals for controlling the external application circuit according to a horizontal synchronization signal, wherein the control signals further associate with a vertical synchronization signal.

[0012] The present invention further discloses a method for controlling a backlight driving circuit. The display controller receives a video source signal, generates a set of parameters corresponding to a display mode by the display controller, and generates a set of control signals associated with a horizontal synchronization signal for the driving circuit by the display controller according to the set of the parameters.

[0013] These and other objectives of the present invention will no doubt become obvious to those of ordinary skill in the art after reading the following detailed description of the preferred embodiment that is illustrated in the various figures and drawings.

## BRIEF DESCRIPTION OF THE DRAWINGS

[0014] FIG. 1 illustrates a block diagram of a prior art transmissive LCD monitor.

[0015] FIG. 2 illustrates a block diagram of a flat panel display device according to a preferred embodiment of the present invention.

[0016] FIG. 3 illustrates a block diagram of the digital PWM module shown in FIG. 2 according to a preferred embodiment of the present invention.

[0017] FIG. 4 illustrates a block diagram of the pulse width modulator shown in FIG. 3 according to a preferred embodiment of the present invention.

[0018] FIG. 5 illustrates a waveform diagram of signal waves corresponding to the pulse width modulator shown in FIG. 4.

[0019] FIG. 6 illustrates a waveform diagram of signals associated with the digital PWM module shown in FIG. 3.

[0020] FIG. 7 illustrates a schematic diagram of the power transformation module shown in FIG. 2.

[0021] FIG. 8 illustrates a schematic diagram of a feedback circuit.

[0022] FIG. 9 illustrates a schematic diagram of an adjustment module.

[0023] FIG. 10 illustrates a schematic diagram of operating frequency changes of the flat panel display device shown in FIG. 2 when operating in a voltage mode.

[0024] FIG. 11 illustrates an equivalent circuit diagram in the flat panel display device at an ignition stage.

[0025] FIG. 12 illustrates an equivalent circuit diagram in the flat panel display device at a current mode.

[0026] FIG. 13 illustrates a schematic diagram of a buffering circuit.

[0027] FIG. 14 illustrates a flowchart of a process for controlling a backlight driving circuit according to a preferred embodiment of the present invention.

[0028] FIG. 15 illustrates a flowchart of a process for controlling a backlight driving circuit according to another embodiment of the present invention.

#### DETAILED DESCRIPTION

[0029] Please refer to FIG. 2, which illustrates a block diagram of a flat panel display device 20 in accordance with a preferred embodiment of the present invention. The flat panel display device 20 includes a display panel 200, a lamp 202, a power transformation module 204, a non-volatile storage unit 212, and a display controller 206. The display controller 206 includes an image processing module 208, a digital PWM module 210, and a microcontroller 214. The flat panel display device 20 preferably includes a feedback circuit 216, an adjustment module 218, a multiplexer 220, and an A/D converter 222. The microcontroller 214 performs program code 224 stored in the non-volatile storage unit 212 to coordinate operations of the display controller 206, to control the display panel 200 and the lamp 202. In the display controller 206, the image processing module 208 receives a video source including an input horizontal synchronization signal IHSYNC, generates an output horizontal synchronization signal OHSYNC, an output vertical synchronization signal OVSYNC, and display data for the display panel 200. The image processing module 208 preferably transmits the input horizontal synchronization signal IHSYNC, the output horizontal synchronization signal OHSYNC, and the output vertical synchronization signal OVSYNC to the digital PWM module 210. The display data includes red, blue, and green signals R, G, and B. According to the input horizontal synchronization signal IHSYNC, the output horizontal synchronization signal OHSYNC, and the output vertical synchronization signal OVSYNC, the digital PWM module 210 controlled by the microcontroller 214 generates control signals Q1 and Q2, so as to control transistors of the power transformation module 204. In this embodiment, according to different operation modes, the digital PWM module 210 can adjust ON time of the transistors in the power transformation module 204 with the control signals Q1 and Q2, so as to control luminance of the lamp 202, while the digital PWM module 210 adjusts luminance of the lamp 202 according to signals outputted

from the feedback circuit 216 and the adjustment module 218. Furthermore, the power transformation module 204 can further generate a plurality of DC voltages for different applications. Notice that, according to the present invention, those skilled in the art can recognize that the power transformation module 204 can be an inverter to control the lamp 202 or a voltage regulator to provide a plurality of voltage sources. The adjustment module 218 and the feedback circuit 216 can share the A/D converter 222 due to low-speed operation, and saves logic gates. Alternatively, two independent A/D converters can be also implemented for converting signals from the adjustment module 218 and the feedback circuit 216 respectively. Moreover, the non-volatile storage unit 212 can be various kind of non-volatile memory, such as flash memory, EEPROM, etc., and the non-volatile storage unit 212 can be outside the display controller 206 or integrated in the display controller 206. Similarly, the microcontroller 214, such as 8051 microcontroller, can be outside the display controller 206 or integrated in the display controller 206. Furthermore, the power transformation module 204 can be utilized for driving not only a CCFL, but also other backlight sources, such as LEDs.

[0030] FIG. 3 illustrates a block diagram of a preferred embodiment of the digital PWM module 210 shown in FIG. 2. The digital PWM module 210 preferably includes a pulse width modulator 300, a control signal generation module 302, and a duty-cycle control module 304. According to the input horizontal synchronization signal IHSYNC, the output horizontal synchronization signal OHSYNC, and the output vertical synchronization signal OVSYNC, the pulse width modulator 300 generates a pulse signal V\_burst to the control signal generation module 302, and the microcontroller 214 controls a frequency of the pulse signal V\_burst. In this embodiment, the control signal generation module 302 toggles control signals Q1\_P and Q2\_P at high state of the pulse signal V\_burst. The duty-cycle control module 304 adjusts duty cycles of the control signals Q1\_P and Q2\_P to prevent overlapping of assertions between the control signals Q1\_P and Q2\_P. If the assertions of Q1 and Q2 are overlapped and received by the power transformation module 204, the power transformation module 204 will keep providing power for the lamp 202, which may burn out the power transformation module 204, such as an inverter circuitry. Through the duty-cycle control module 304, the assertions of Q1\_P and Q2\_P are prevented from overlapping, so are the control signals Q1 and Q2 received by the power transformation module 204. Preferably, the duty-cycle control module 304 adjusts the duty cycles of the control signals Q1 and Q2 according to an output voltage V<sub>o</sub>.

[0031] FIG. 4 illustrates a block diagram of a preferred embodiment of the pulse width modulator 300 shown in FIG. 3. The pulse width modulator 300 includes a multiplexer 400, a digital PLL module 402, a comparator 404, and dividers 406, 408, 410, and 412. The multiplexer 400 is controlled by the microcontroller 214, and utilized for outputting a signal VHSYNC to the divider 406 according to the input horizontal synchronization signal IHSYNC or the output horizontal synchronization signal OHSYNC. The dividers 406, 408, 410, and 412 divide received signals by divisors N, J, K, and M. The digital PLL module 402 receives a clock signal CLK, and adjusts a frequency of signals outputted to the divider 408 according to signals outputted from the dividers 406 and 412. In this embodiment, the divisors N, J, K, and M are determined by the

microcontroller **214**, obtained by inquiring a look-up table, and associated with the horizontal and vertical synchronization signals received by the multiplexer **400**. Suppose that a frequency of the signal  $V_{HSYNC}$  outputted from the multiplexer **400** is  $f_{HSYNC}$ , and a frequency of a signal  $V_{PWM}$  outputted from the divider **408** is  $f_{PWM}$ , then a frequency of a signal inputted to the digital PLL module **402** is  $(f_{HSYNC} \times (M/N) \times J)$ . After being synchronized by the digital PLL module **402**,  $f_{PWM} = f_{HSYNC} \times (M/N)$ , and a frequency of the pulse signal  $V_{burst}$  is  $f_{burst} = f_{PWM} / K$ . Furthermore, the frequency  $f_{burst}$  of the pulse signal  $V_{burst}$  can be synchronized with the frequency  $f_{VSYNC}$  of the vertical synchronization signal  $V_{VSYNC}$ . For example, set  $(f_{HSYNC} \times M/N/K)$  is an integral multiple of the frequency  $f_{VSYNC}$ , eg. 3 or 4 times, then the frequency of the signal outputted from the power transformation module **204** is associated with the frequencies of the vertical and horizontal synchronization signals, so as to prevent visible signal interference, such as ripples on the display panel **200**. The comparator **404** determines the duty cycle of the pulse signal  $V_{burst}$  according to the signal  $L$  outputted from the microcontroller **214**.

[0032] Please refer to FIG. 5, which illustrates a waveform diagram of signals associated with the pulse width modulator **300** shown in FIG. 4. As shown in FIG. 5, the divisor  $K$  determines the frequency of the pulse signal  $V_{burst}$ . The greater the divisor  $K$ , the longer the period of the pulse signal  $V_{burst}$  is. The parameter  $L$  determines a duty cycle of the pulse signal  $V_{burst}$ . The smaller the parameter  $L$ , the shorter the positive duration of each square wave of the pulse signal  $V_{burst}$  is. Therefore, by adjusting the divisor  $K$  and the parameter  $L$ , the frequencies and the duty cycles of the control signals  $Q1$  and  $Q2$  outputted to the power transformation module **204** are controlled, and thus luminance of the lamp can be adjusted.

[0033] Refer to FIG. 3 again, the control signal generation module **302** generates the square-wave signals  $Q1\_P$  and  $Q2\_P$  during positive square waves of the pulse signal  $V_{burst}$ , and the duty-cycle control module **304** can adjust the duty cycles of the square-wave signals  $Q1\_P$  and  $Q2\_P$ , so as to prevent the lamp **202** from burning out due to overlapping between the square-wave signals  $Q1\_P$  and  $Q2\_P$ . Please refer to FIG. 6, which illustrates a waveform diagram of signals associated with the digital PWM module **210** shown in FIG. 3. The control signal generation module **302** toggles the square-wave signals  $Q1\_P$  and  $Q2\_P$  during positive square waves of the pulse signal  $V_{burst}$ , and the duty-cycle control module **304** can adjust the duty cycles of the square-wave signals  $Q1\_P$  and  $Q2\_P$ . Preferably, the duty cycles of the square-wave signals  $Q1\_P$  and  $Q2\_P$  are 45%, and assertion durations of the control signals  $Q1$  and  $Q2$  are separated without overlapping.

[0034] Please refer to FIG. 7, which illustrates a schematic diagram of the power transformation module **204** shown in FIG. 2. According to the control signals  $Q1$  and  $Q2$  provided by the digital PWM module **210**, the power transformation module **204** switches the transistors **702** and **704** to control a primary end of a transformer **700** and adjust luminance of the lamp **202** coupled to a secondary end of the transformer **700**. As shown in FIG. 3, when the pulse signal  $V_{burst}$  outputted from the pulse width modulator **300** is high, the control signal generation module **302** toggles the control signals. As mentioned above, the frequency of the pulse

signal  $V_{burst}$  is determined by the divisors  $N$ ,  $J$ ,  $K$ , and  $M$ , and the duty cycle of the pulse signal  $V_{burst}$  is determined by the parameter  $L$ . Therefore, by adjusting  $N$ ,  $J$ ,  $K$ ,  $M$ , and  $L$ , the frequencies and periods of the control signals  $Q1$  and  $Q2$  can be adjusted. For example, increasing a value of the parameter  $L$  can increase on time of the transformer **700** shown in FIG. 7, so that lighting period of the lamp **202** increases, and thus brightness of the lamp **202** is increased. Preferably, values of  $N$ ,  $J$ ,  $K$ ,  $M$ , and  $L$  corresponding to different brightness can be stored in the non-volatile storage unit **212**, and the microcontroller **214** can obtain the values of  $N$ ,  $J$ ,  $K$ ,  $M$ , and  $L$  corresponding to a required brightness when adjusting brightness of the lamp **202**. Preferably, the secondary end of the transformer **700** and the lamp **202** provide feedback signals to the display controller **206** from the feedback circuit **216** through the terminals **706** and **708**.

[0035] FIG. 8 illustrates a schematic diagram of the feedback circuit **216**. The feedback circuit **216** can generate a feedback voltage  $V_{FB}$  and a feedback current  $I_{FB}$  according to signals outputted from the secondary end of the transformer **700** and the lamp **202**. Moreover, the feedback circuit **216** can feedback an input voltage  $V_{in}$  provided to the power transformation module **204** and an open-lamp protection signal  $OLPZ$  (not shown in FIG. 8) to the display controller **206**, which is useful for portable or multi-lamp applications.

[0036] FIG. 9 illustrates a schematic diagram of the adjustment module **218** shown in FIG. 2, including a resistor **900**, switches  $SW\_1$  to  $SW\_n$ , and resistors  $R_{SW1}$  to  $R_{SWn}$ . The switches  $SW\_1$  to  $SW\_n$  are turned off initially, and corresponding to specific items respectively, such as menu, volume up, volume down, etc. If one of the switches  $SW\_1$  to  $SW\_n$  is turned on, resistance from a system voltage source  $V_{cc}$  to a system ground is changed, and a voltage  $V_{SW}$  outputted to the display controller **206** is changed accordingly. Therefore, according to the voltage  $V_{SW}$ , the microcontroller **214** can adjust an operating status of the display controller **206**, such as brightness of the lamp **202**, contrast of the display panel **200**, etc.

[0037] In this embodiment, the digital PWM module **210** adjusts brightness of the lamp **202** according to the vertical and horizontal synchronization signals. Therefore, luminance frequency of the lamp **202** associates with display frequency of the display panel **200**, and thus display quality can be improved. Take XGA for example, suppose that the display frequency of the flat panel display device **20** is 60 HZ, each frame includes 1344 horizontal lines and 804 vertical lines ( $V_{TOTAL} = 804$ ), then the vertical synchronization signal and the pulse signal  $V_{burst}$  is synchronized as follows:

$$\begin{aligned} f_{VSYNC} &= 60 \text{ and } V_{TOTAL} = 804 \\ \text{then} \\ f_{HSYNC} &= f_{VSYNC} * V_{TOTAL} = 60 * 804 = 48240 \\ f_{PWM} &= (M/N) * 60 * 804 \\ \text{set } f_{burst} &= 4 * f_{VSYNC} = 240 \\ \text{then } (M/N) * (1/K) &= 4 / V_{TOTAL} = 4 / 804 \\ \text{choose} \\ M=1, N=1, K &= 201 \end{aligned}$$

[0038] Therefore,  $f_{burst} = 240$  HZ, and  $f_{PWM} = 48.24$  KHZ. Similarly, for SXGA, suppose that the display frequency of

the flat panel display device **20** is 60 HZ, each frame includes 1688 horizontal lines and 1056 vertical lines ( $V_{TOTAL}=1056$ ), then:

$f_{VSYNC}=60$  and  $V_{TOTAL}=1056$   
 then  
 $f_{HSYNC}=60 \times 1056 = 63360$   
 $f_{PWM}=(M/N) \times 60 \times 804$   
 set  $f_{burst}=4 \times f_{VSYNC}=240$   
 then  $(M/N) \times (1/K)=4/V_{TOTAL}=4/1056$   
 choose  
 $M=5, N=6, K=220$

[0039] Therefore,  $f_{burst}=240$  HZ, and  $f_{PWM}=52.8$  KHZ. Then, according to the values of M, N, and K corresponding to the display qualities (ex. XGA and SXGA) stored in the non-volatile storage unit **212**, the microcontroller **214** can synchronize the luminance frequency of the lamp **202** and the display frequency of the display panel **200**. Moreover, increasing or decreasing brightness of the lamp **202** can be achieved by adjusting the value of the parameter L for changing the operation cycles of the control signals Q1 and Q2.

[0040] In other words, the operation cycles of the control signals Q1 and Q2 associate with the frequency  $f_{HSYNC}$  of the horizontal synchronization signal HSYNC and the  $f_{VSYNC}$  of the vertical synchronization signal VSYNC, and thus an ignition frequency (or starting frequency) of the lamp **202** associates with the frequencies  $f_{HSYNC}$  and  $f_{VSYNC}$ . Therefore, ripples caused by non-synchronization between the display frequency and the ignition frequency of the lamp **202** can be relieved.

[0041] Preferably, the flat panel display device **20** can operate in a plurality of operation modes, and associated operation program code **224** is designed and stored in the non-volatile storage unit **212** in advance. Please refer to FIG. **10**, at an ignition stage, the flat panel display device **20** operates in a voltage mode, and operating frequencies are 50 KHZ from time points **0** to T1 and 60 KHZ from time points T1 to T2. Please refer to FIG. **11**, which illustrates an equivalent circuit diagram of the program code **224** at the ignition stage. Notice that, elements of the circuit shown in FIG. **11** are utilized for narrating the operation of the program code **224**, but are not required physically. An algorithm of the voltage mode is concluded as follows, where  $V_{FB}(n)$ ,  $V_{in}(n)$  are results of the voltages  $V_{FB}$  and  $V_{in}$  after being converted by the A/D converter **222**, and T represents sampling time:

$$I_o(n)=(V_{COM}-V_{FB}(n)) \times G/V_{in}(n)$$

$$V_o(n+1)=I_o(n) \times R+V_c(n)+I_o(n) \times T/C$$

[0042] Wherein  $V_c(0)=0$  begins soft start.

[0043] Being divided by  $V_{in}(n)$  is to compensate variation of the input voltage  $V_{in}$ . After the open-lamp protection signal OLPZ stays in a high level for a predetermined duration, the program code **224** can then entering a current mode. Please refer to FIG. **12**, which illustrates an equivalent circuit diagram of the program code **224** at the current mode. An algorithm of the current mode is as follows:

$$I_o(n)=(I_{COM}-I_{FB}(n)) \times G/V_{in}(n)$$

$$V_o(n+1)=I_o(n) \times R+V_c(n)+I_o(n) \times T/C$$

[0044] When  $V_c(0)=0$ , soft start.

[0045] In FIGS. **11** and **12**, the blocks of  $1/V_{in}(n)$  compensate variation of the input voltage  $V_{in}$ , especially for flat panel display devices having unstable input voltages, such as portable or vehicle flat panel display devices. Of course, for flat panel display devices having stable input voltages, the block of  $1/V_{in}(n)$  is unnecessary. Note that, the circuits shown in FIGS. **11** and **12** are equivalent circuits of the program code **224**, but are not required physically, so that the present invention can realize any desired performance of the flat panel display device **20** by flexibly adjusting resistors and capacitors in the equivalent circuits.

[0046] In the current mode, the present invention can preferably drive the flat panel display device **20** in a burst mode, in which the operating frequency is synchronized with an integral multiple, e.g. 3 or 4 of the frequency of the vertical synchronization signal. In the voltage mode, stable voltages are provided, so as to drive the lamp **202** at the ignition stage. In the current mode, stable currents are provided, so as to drive the lamp **202** with highest luminance. In the burst mode, luminance of the lamp **202** can be well-controlled by adjusting the resistor R, the capacitor C, and the gain G of the equivalent circuit of the program code **224**. For example, when the raising and descending speeds of the output voltage  $V_o$  are high, dimming control of the lamp **202** is efficient. When the raising and descending speeds of the output voltage  $V_o$  are low, audible noises of the transformer can be eliminated.

[0047] Regarding fail-safe protection, the present invention can reset the transformer **700** when a user adjusts the display panel through the adjustment module **218** or turns on and off AC power. In order to prevent the microcontroller **214** from dead lock, an output pin of the display controller **206** can be coupled to a buffering circuit, such as a buffering circuit **1300** shown in FIG. **13**, through a de-coupling capacitor. Preferably, the control signals Q1 and Q2 are set to the high level when the microcontroller **214** is in an uncertain state or just started.

[0048] FIG. **14** illustrates a flowchart of a method for controlling a backlight driving circuit in accordance with a preferred embodiment of the present invention. The driving circuit can be used for driving a CCFL. The method starts at step **1400** and finishes at step **1480**. In a step **1420**, a display controller generates a set of control signals for the driving circuit, preferably including the first transistor control signal Q1 and the second transistor control signal Q2 shown in FIG. **2**, which are separated without overlapping. The set of the control signals are associated with an input horizontal synchronization signal or an output horizontal synchronization signal, preferably in an integral multiple of frequency or in an rising edge or falling edge alignment relationship, so as to remove visible interference on a display panel. In a step **1440**, the display controller receives a set of feedback signals from the driving circuit, preferably including a current feedback signal  $I_{FB}$ , a voltage feedback signal  $V_{FB}$ , an input voltage signal  $V_{in}$ , and an open-circuit detection signal OPLZ.

[0049] In a step **1460**, according to the set of the feedback signals, the display controller adjusts the set of the control signals for operating the driving circuit in a plurality of operation modes, preferably including a voltage mode, a current mode, and a burst mode. For example, when the CCFL is at an ignition stage, the step **1460** adjusts the set of

the control signals to operate the driving circuit in the voltage mode with stable voltages. When the CCFL is at a normal operation stage, the step 1460 adjusts the set of the control signals to operate the driving circuit in the current mode with sufficient current. When the CCFL is at a dimming stage, the step 1460 adjusts the set of the control signals to operate the driving circuit in the burst mode, so as to adjust luminance of the CCFL by changing duty cycles of the control signals. For example, a digital PWM module generates the set of the control signals for the driving circuit, including the first transistor control signal Q1 and the second transistor control signal Q2. The display controller calculates an output voltage  $V_o(n+1)$  according to the set of the feedback signals, and the digital PWM module adjusts duty cycles of the set of the control signals according to the output voltage  $V_o(n+1)$ .

[0050] In the voltage mode, signals  $V_{FB}(n)$  and  $V_{in}(n)$  are obtained by sampling the voltage feedback signal  $V_{FB}$  and the input voltage signal  $V_{in}$ , and the output voltage  $V_o(n+1)$  can be calculated as follows:

$$I_o(n) = (V_{COM} - V_{FB}(n)) \times G / V_{in}(n)$$

$$V_o(n+1) = I_o(n) \times R + V_c(n) + I_o(n) \times T / C$$

[0051] where R, C, and G represents parameters of a resistor, a capacitor, and a gain,  $V_{COM}$  represents a voltage comparison value, T represents time,  $I_o(n)$  represents a sampled output current, and  $V_c(n)$  represents a crossing voltage between two ends of the capacitor with an initial value  $V_c(0)=0$ .

[0052] In the current mode, signals  $I_{FB}(n)$  and  $V_{in}(n)$  are obtained by sampling the current feedback signal  $I_{FB}$  and the input voltage signal  $V_{in}$ , and the output voltage  $V_o(n+1)$  can be calculated as follows:

$$I_o(n) = (I_{COM} - I_{FB}(n)) \times G / V_{in}(n)$$

$$V_o(n+1) = I_o(n) \times R + V_c(n) + I_o(n) \times T / C$$

[0053] wherein R, C, and G represents parameters of a resistor, a capacitor, and a gain,  $I_{COM}$  represents a reference current value, T represents time,  $I_o(n)$  represents a sampled output current, and  $V_c(n)$  represents a crossing voltage of the capacitor with an initial value  $V_c(0)=0$ .

[0054] FIG. 15 illustrates a flowchart of a process for controlling a backlight driving circuit in accordance with an embodiment of the present invention. The driving circuit can be used for driving a CCFL. The process starts from a step 1500 and finishes at a step 1580. In a step 1520, a display controller receives a video source. In a step 1540, the display controller generates a set of parameters by inquiring a look-up table in response to a display mode, preferably including VGA, XGA, SXGA, WGA, WXGA, etc. The set of the parameters can be the associated parameters shown in FIG. 4. In a step 1560, according to the set of the parameters, the display controller generates a set of control signals associated with an input horizontal synchronization signal or an output horizontal synchronization signal for the backlight driving circuit.

[0055] In summary, the frequencies of the control signals Q1 and Q2 generated by the digital PWM module 210 associates with the display frequency of the display panel 200, so that a switching frequency of the lamp 202 is associated with the display frequency of the display panel 200. Thus, the visible interference on the display is effectively

relieved, and display quality is improved. Preferably, the digital PWM module 210 is integrated into the display controller 206. Persons skilled in the art can realize that the digital PWM module 210 can drive the power transformation module 204 to light up not only the CCFL, but also other kinds of backlight sources, such as LED. Also, the resistor R, the capacitor C, and the gain G can be adjusted to reach any required performance of system manufacturers.

[0056] Those skilled in the art will readily observe that numerous modifications and alterations of the device and method may be made while retaining the teachings of the invention. Accordingly, the above disclosure should be construed as limited only by the metes and bounds of the appended claims.

What is claimed is:

1. A flat panel display device, comprising:

a display panel;

a lamp for providing a backlight source for the display panel;

a power transformation module for providing a power source for the lamp;

a non-volatile storage unit for storing program code; and

a display controller, comprising:

an image processing module for processing a video source and outputting a processed results to the display panel; and

a digital pulse width modulation module for controlling the power transformation module according to a synchronization signal.

2. The flat panel display device of claim 1, wherein the display controller further comprises a microcontroller for performing the program code stored in the non-volatile storage unit.

3. The flat panel display device of claim 2, wherein the power transformation module comprises:

a transformer having a primary end and a secondary end coupled to the lamp; and

a plurality of switch transistors coupled to the primary end and the digital pulse width modulation module, for switching current direction of the primary end according to a plurality of square waveforms outputted from the digital pulse width modulation module.

4. The flat panel display device of claim 2, wherein the digital pulse width modulation module adjusts duty cycles of the square waveforms for adjusting on and off time of the power transformation module to control a luminance of the lamp.

5. The flat panel display device of claim 4, wherein the digital pulse width modulation module comprises:

a pulse width modulator for generating a plurality of first square waveforms and adjusting duty cycles of the first square waveforms in response to a control signal from the microcontroller; and

a control signal generation module for outputting a plurality of second square waveforms to the power transformation module during positive durations of the first square waveforms;

wherein each duty cycle of the second square waveforms is smaller than that of the first square waveforms.

6. The flat panel display device of claim 5, wherein the second square waveforms comprise a first control signal and a second control signal.

7. The flat panel display device of claim 6, wherein assertion duration of the first control signal is separated from that of assertion duration of the second control signal.

8. The flat panel display device of claim 5, wherein the pulse width modulator comprises:

a multiplexer for receiving an input horizontal synchronization signal and an output horizontal synchronization signal, to selectively output the input horizontal synchronization signal or the output horizontal synchronization signal;

a first divider coupled to the multiplexer, for generating a first output signal by dividing a frequency of an output from the multiplexer by a first divisor;

a phase lock loop unit for generating a phase lock signal;

a second divider for generating a second output signal by dividing a frequency of the phase lock signal by a second divisor;

a third divider for generating a third output signal by dividing a frequency of the second output signal by a third divisor;

a fourth divider for generating a fourth output signal by dividing the frequency of the second output signal by a fourth divisor; and

a comparator for comparing a threshold value and the fourth output signal, and outputting corresponding square waveforms to the control signal generation module;

wherein the phase lock loop unit generates the phase lock signal according to the first output signal and the third output signal.

9. The flat panel display device of claim 5, wherein the digital pulse width modulation module further comprises a duty-cycle control module for adjusting duty cycles of the second square waveforms to prevent overlapping in the second square waveforms.

10. The flat panel display device of claim 1, wherein the program code stored in the non-volatile storage unit comprises controlling a frequency of signals outputted from the digital pulse width modulation module according to a horizontal synchronization signal and a vertical synchronization signal generated by the image processing module.

11. The flat panel display device of claim 1, further comprising:

a feedback circuit coupled to the lamp for outputting a sensing current of the lamp; and

an analog to digital converter coupled between the feedback circuit and the display controller, for converting analog signals outputted from the feedback circuit into digital signals.

12. The flat panel display device of claim 11, wherein the microcontroller controls a frequency of signals outputted from the digital pulse width modulation module according to the digital signals outputted from the analog to digital converter.

13. The flat panel display device of claim 11, further comprises an adjustment module coupled to the analog to digital converter, for adjusting a plurality of display functions of the display controller, comprising:

a power source;

a resistor coupled to the power source;

a resistor sequence coupled to the resistor, comprising a plurality of resistors in series connection;

a plurality of switches each coupled between the resistor sequence and ground; and

an output terminal between the resistor and the resistor sequence, for outputting voltage to the analog to digital converter.

14. A display controller of a flat panel display device, comprising:

an image processing module for processing image data; and

a digital pulse width modulation module coupled to the image processing module and an external application circuit, for generating a set of control signals for controlling the external application circuit according to a synchronization signal.

15. The display controller of claim 14, wherein the external application circuit is a power transformation module for providing an alternating-current voltage.

16. The display controller of claim 14, wherein the external application circuit is a power transformation module for driving a plurality of light emitting diodes.

17. The display controller of claim 14, wherein the external application circuit is a power transformation module for driving a lamp.

18. The display controller of claim 17, wherein the lamp is a cold cathode fluorescent lamp.

19. The display controller of claim 14, wherein the synchronization signal is an input horizontal synchronization signal.

20. The display controller of claim 14, wherein the synchronization signal is an output horizontal synchronization signal.

21. The display controller of claim 18, wherein the external application circuit controls on and off time of the cold cathode fluorescent lamp.

22. The display controller of claim 14, wherein the digital pulse width modulation module adjusts duty cycles of square waveforms for adjusting on and off time of the power transformation module for controlling luminance of the lamp.

23. The display controller of claim 14, wherein the digital pulse width modulation module comprises:

a pulse width modulator for generating a plurality of first square waveforms and adjusting duty cycles of the first square waveforms according to signals outputted from the image processing module; and

a control signal generation module for outputting a plurality of second square waveforms to the external application circuit during positive durations of the first square waveforms;

wherein each duty cycle of the second square waveforms is smaller than that of the first square waveforms.

**24.** The display controller of claim 23, wherein the second square waveforms are formed by interlacing a first control signal and a second control signal, and assertion duration of the first control signal is separated from that of assertion duration of the second control signal.

**25.** The display controller of claim 23, wherein the pulse width modulator comprises:

a multiplexer for receiving an input horizontal synchronization signal and an output horizontal synchronization signal, to selectively output the input horizontal synchronization signal or the output horizontal synchronization signal;

a first divider coupled to the multiplexer, for generating a first output signal by dividing a frequency of an output from the multiplexer by a first divisor;

a phase lock loop unit for generating a phase lock signal;

a second divider for generating a second output signal by dividing a frequency of the phase lock signal by a second divisor;

a third divider for generating a third output signal by dividing a frequency of the second output signal by a third divisor;

a fourth divider for generating a fourth output signal by dividing the frequency of the second output signal by a fourth divisor; and

a comparator for comparing a threshold value and the fourth output signal, to generate a comparison output to the control signal generation module;

wherein the phase lock loop unit generates the phase lock signal according to the first output signal and the third output signal.

**26.** The display controller of claim 23, wherein the digital pulse width modulation module further comprises a duty-cycle control module for adjusting duty cycles of the second square waveforms to prevent overlapping in the second square waveforms.

**27.** The display controller of claim 14, wherein the synchronization signal is a horizontal synchronization signal and the set of control signals associate with a vertical synchronization signal.

**28.** A method for controlling a backlight driving circuit, comprising:

a display controller receiving a video source signal;

generating a set of parameters corresponding to a display mode by the display controller; and

generating a set of control signals associated with a synchronization signal for the backlight driving circuit by the display controller according to the set of the parameters.

**29.** The method of claim 28, wherein the synchronization signal is an input horizontal synchronization signal.

**30.** The method of claim 28, wherein the synchronization signal is an output horizontal synchronization signal.

**31.** The method of claim 28, wherein the set of the parameters are generated by querying a look-up table.

**32.** The method of claim 28, wherein the display mode is a display mode selected from a group consisting of VGA, XGA, SXGA, WGA, and WXGA.

**33.** The method of claim 28, wherein the synchronization signal is a horizontal synchronization signal and the set of control signals associate with a vertical synchronization signal.

\* \* \* \* \*

专利名称(译)	平板显示设备，控制器和用于显示图像的方法		
公开(公告)号	<a href="#">US20070001998A1</a>	公开(公告)日	2007-01-04
申请号	US11/423149	申请日	2006-06-09
[标]申请(专利权)人(译)	SMITH STERLING 张之洞田		
申请(专利权)人(译)	SMITH STERLING 张之洞田		
当前申请(专利权)人(译)	SMITH STERLING 张之洞田		
[标]发明人	SMITH STERLING CHANG CHIH TIEN		
发明人	SMITH, STERLING CHANG, CHIH-TIEN		
IPC分类号	G09G3/36		
CPC分类号	G09G3/20 G09G3/3406 G09G2320/064 G09G2320/02 G09G2320/0233 G09G2310/08		
优先权	60/694687 2005-06-29 US 60/596141 2005-09-02 US		
其他公开文献	US8542181		
外部链接	<a href="#">Espacenet</a> <a href="#">USPTO</a>		

摘要(译)

提供了一种平板显示装置，LCD控制器和相关方法。平板显示装置包括显示面板，用于为显示面板提供背光源的灯，用于为灯提供电源的电源转换模块，用于存储程序代码的非易失性存储单元，以及显示控制器。显示控制器包括：图像处理模块，用于处理图像数据并将处理结果输出到显示面板；以及数字脉冲宽度调制模块，用于根据同步信号调节电力变换模块的接通和断开时间。

