



US 20050265048A1

(19) **United States**

(12) **Patent Application Publication** (10) **Pub. No.: US 2005/0265048 A1**

Wang et al.

(43) **Pub. Date: Dec. 1, 2005**

(54) **BACK LIGHT MODULE AND SYSTEM FOR LIQUID CRYSTAL PANELS**

(30) **Foreign Application Priority Data**

May 11, 2004 (TW)..... 93113243

(75) Inventors: **Tzuchang Wang, (US); Shunta Hong, (US)**

Publication Classification

Correspondence Address:
**TOWNSEND AND TOWNSEND AND CREW, LLP
TWO EMBARCADERO CENTER
EIGHTH FLOOR
SAN FRANCISCO, CA 94111-3834 (US)**

(51) **Int. Cl.⁷ G02F 1/1335**

(52) **U.S. Cl. 362/612**

(57) **ABSTRACT**

A back light module for a liquid crystal display. The module has a rear cover, a reflective film and a high-reflective mode frame. The rear cover has a bottom plate and a side plate; a first side of the side plate is connected to a side of the bottom plate. The reflective film is disposed on a top surface of the bottom plate and an internal side surface, so as to replace a lamp reflector. The high-reflective mode frame is put on the second side, which is opposite the first side of the side plate.

(73) Assignee: **Chi Mei Optoelectronics Corp., Tainan Science Based Industrial Park (TW)**

(21) Appl. No.: **11/123,847**

(22) Filed: **May 6, 2005**

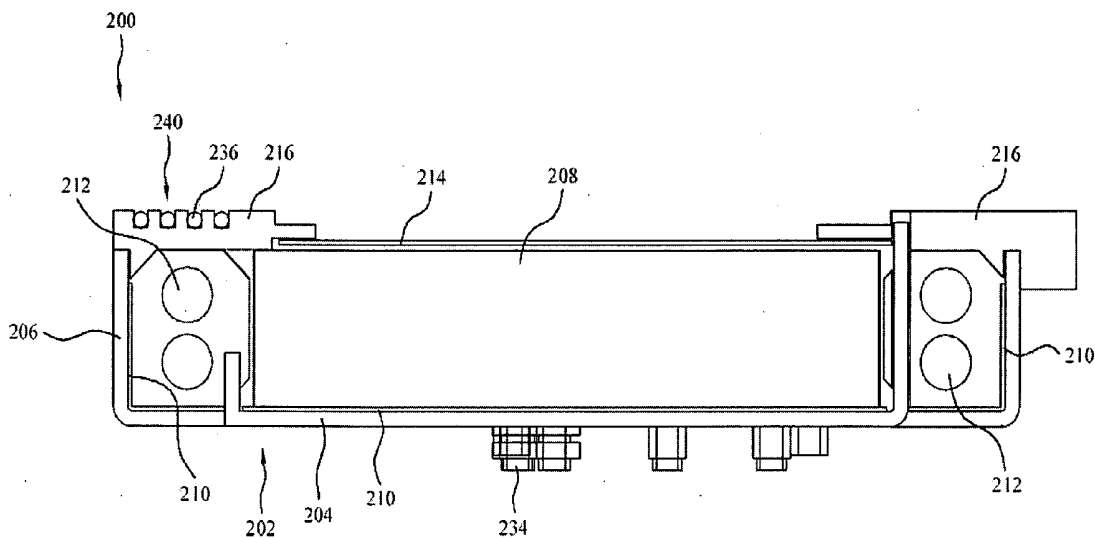

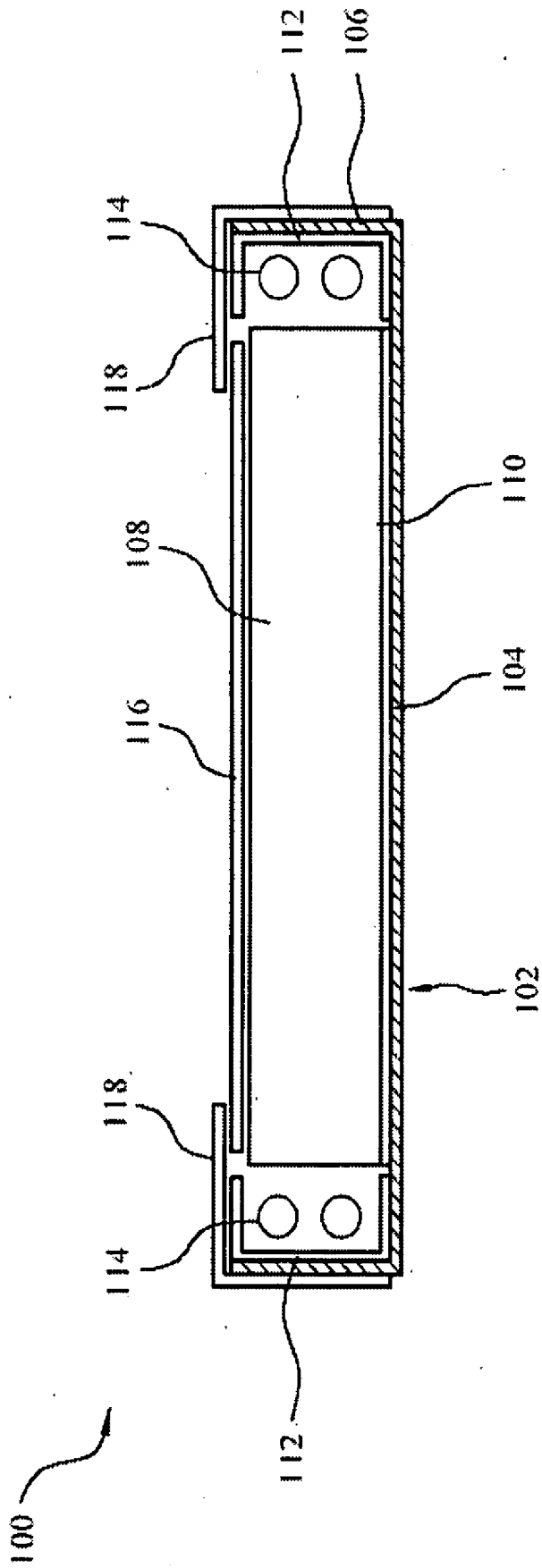

FIG. 1 (PRIOR ART)

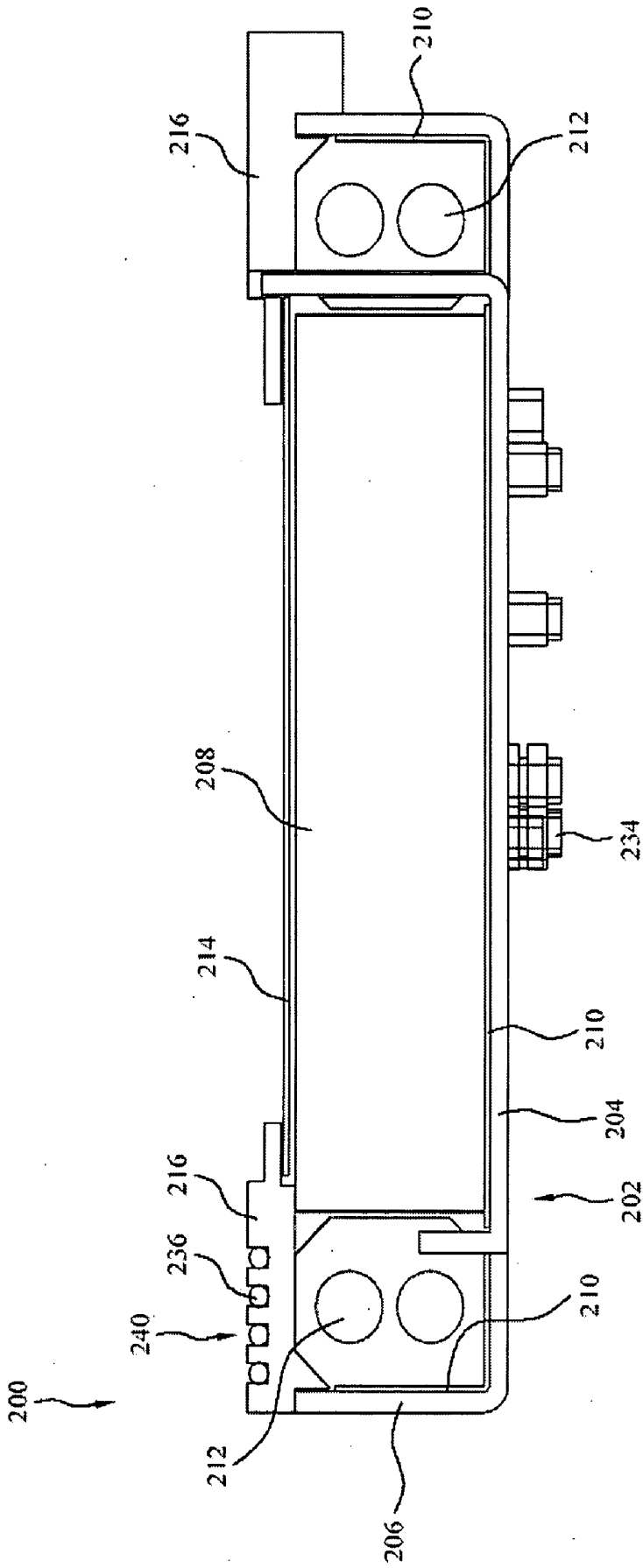

FIG. 2

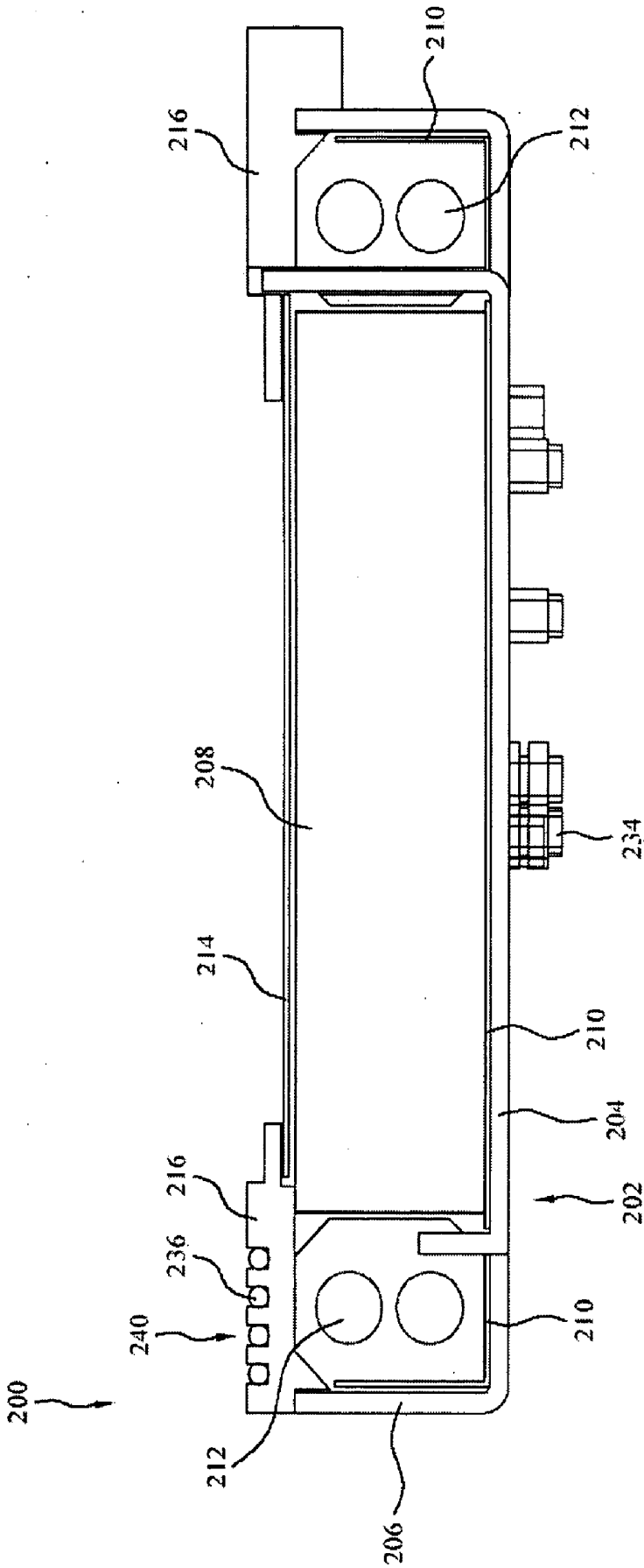

FIG. 3

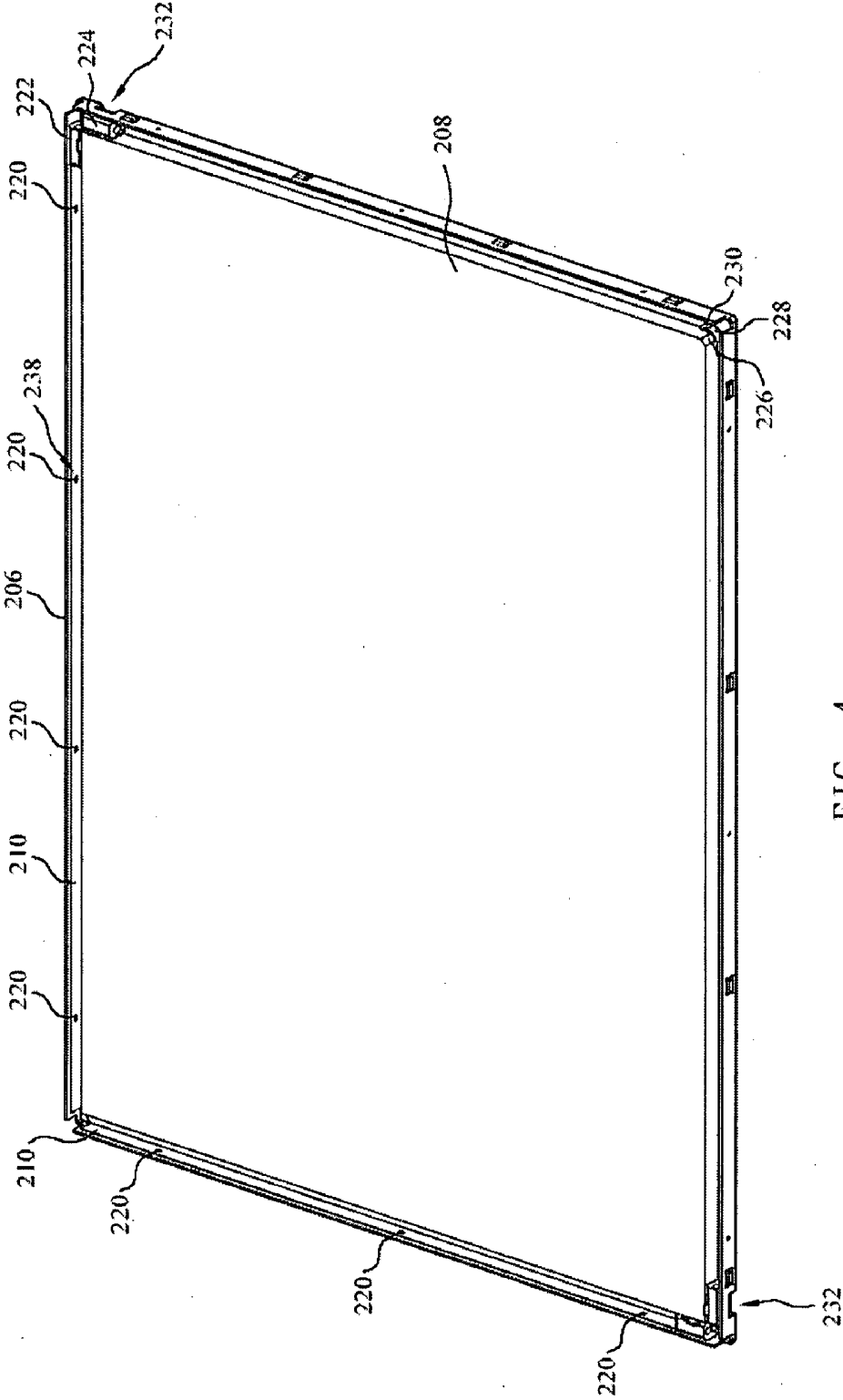

FIG. 4

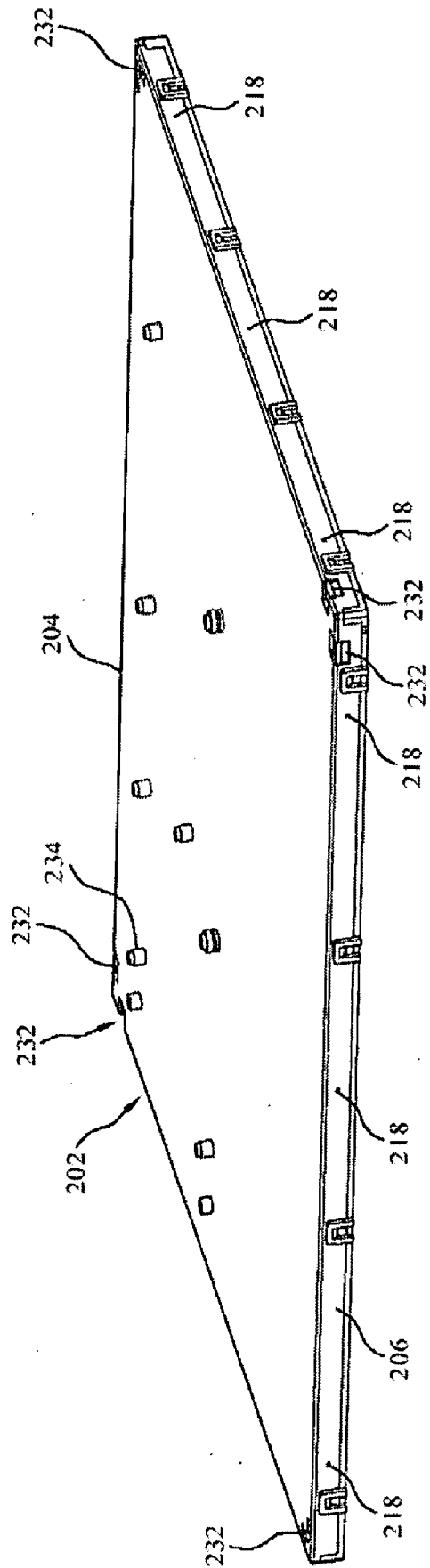

FIG. 5

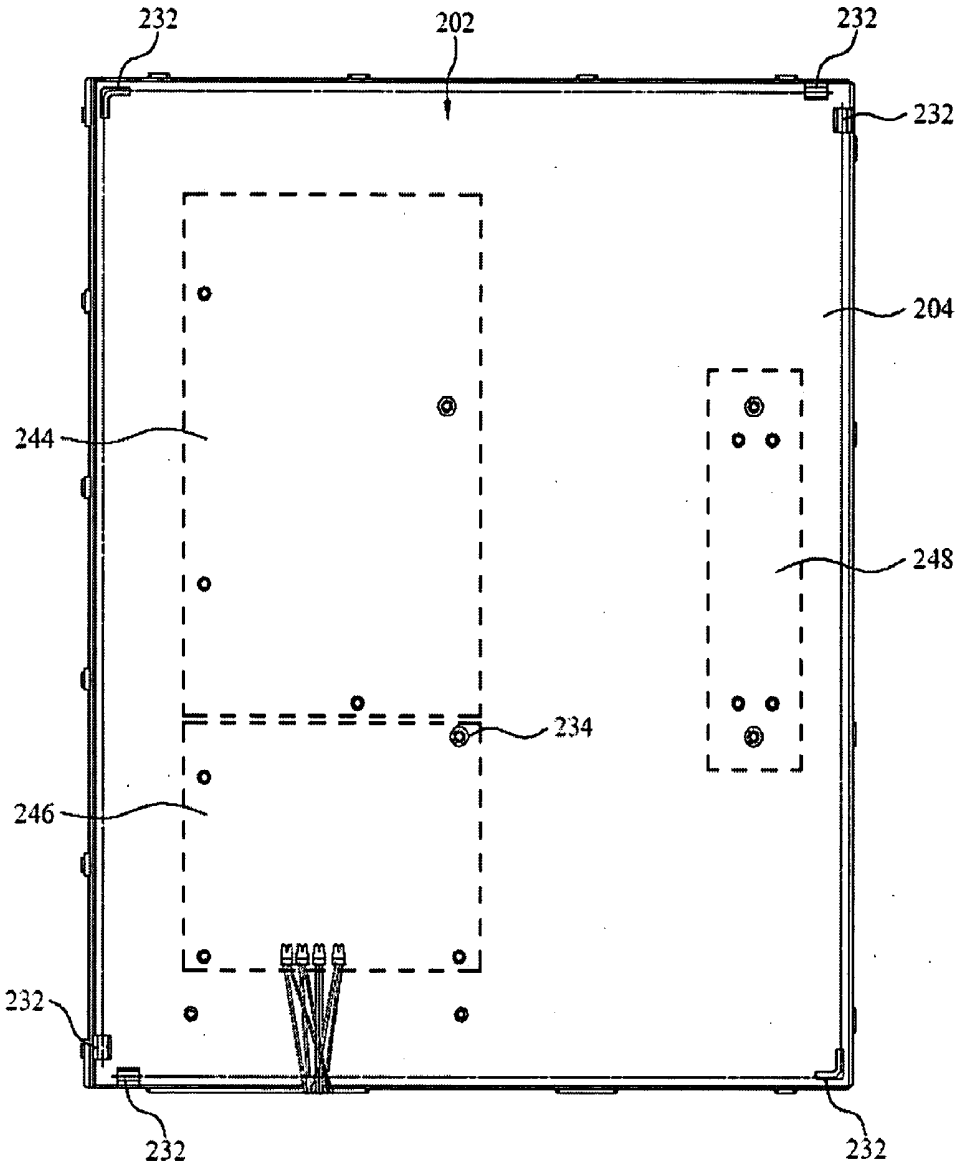

FIG. 6

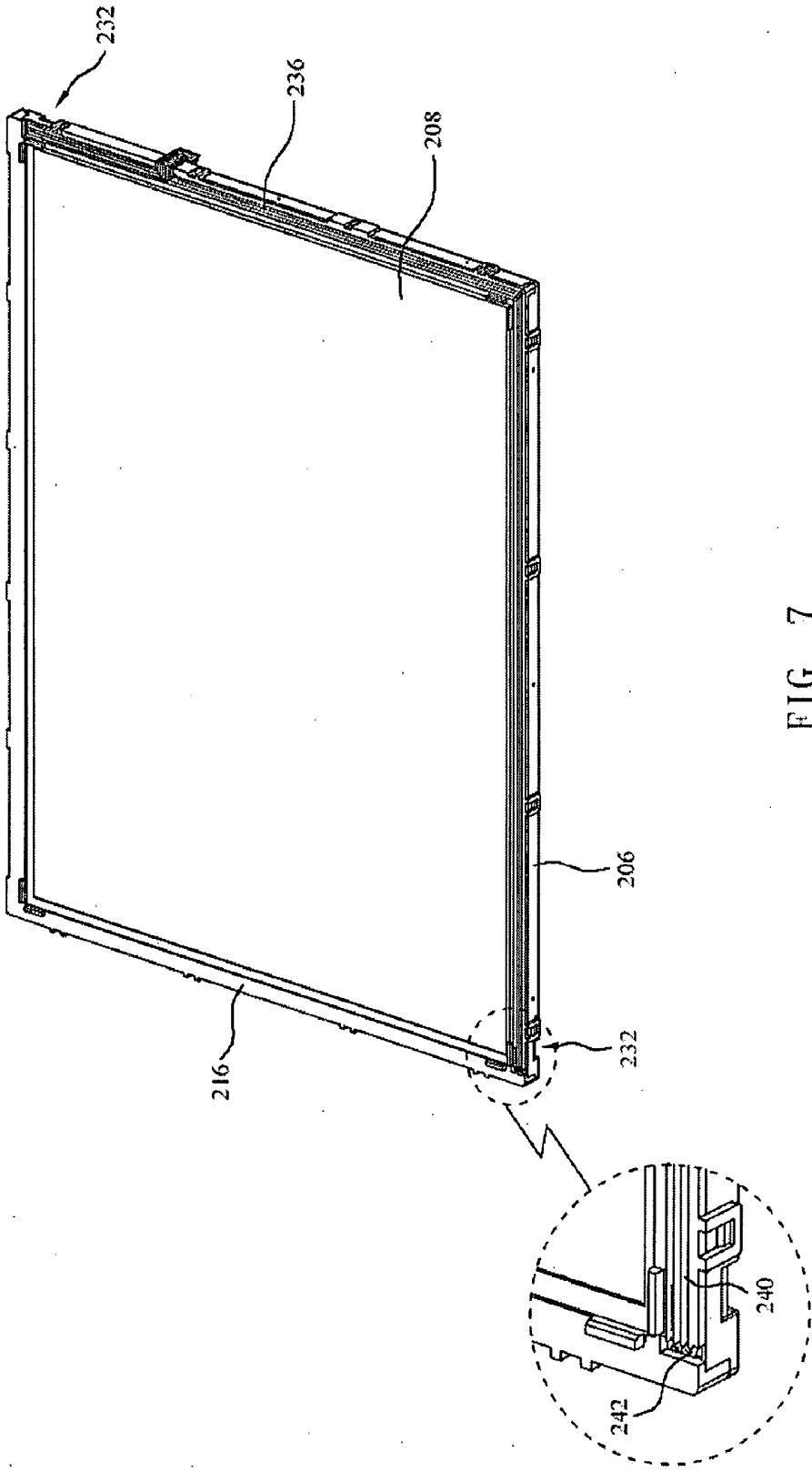

FIG. 7

BACK LIGHT MODULE AND SYSTEM FOR LIQUID CRYSTAL PANELS

CROSS-REFERENCE TO RELATED APPLICATION

[0001] The instant nonprovisional patent application claims priority to Taiwanese Patent Application No. 93113243, filed May 11, 2004 and incorporated by reference herein for all purposes.

BACKGROUND OF THE INVENTION

[0002] The present invention relates to a liquid crystal panels. More particularly, the present invention provides a back light module including an edge-type back light module for a liquid crystal panel. But it would be recognized that the invention has a much broader range of applicability.

[0003] Electronic display technologies have rapidly developed over the years. From the early days, cathode ray tube technology, commonly called CRTs, outputted selected pixel elements onto a glass screen in conventional television sets. These television sets originally output black and white moving pictures. Color television sets soon replaced most if not all black and white television units. Although very successful, CRTs were often bulky, difficult to make larger, and had other limitations.

[0004] CRTs were soon replaced, at least in part, with liquid crystal panel displays. These liquid crystal panel displays commonly called LCDs used an array of transistor elements coupled to a liquid crystal material and color filter to output moving pictures in color. Many computer terminals and smaller display devices often relied upon LCDs to output video, text, and other visual features. Various components make up the LCD display. As merely an example, a back light module is one of the key components of a liquid crystal panel. Since liquid crystals cannot emit light, the back light module provides a light source of sufficient brightness and uniformity, so that the liquid crystal can provide display images of normal and uniform brightness.

[0005] Referring to FIG. 1, a cross-sectional view of a back light module of a conventional liquid crystal display device has been illustrated. The back light module 100 of the conventional liquid crystal display device is an edge-type back light module. The back light module 100 includes a rear cover 102, and the rear cover 102 is mainly composed of a bottom plate 104 and a side plate 106 surrounding the bottom plate 104. An edge of the side plate 106 is joined to an edge of the bottom plate 104 at about 90 degrees. A reflective sheet 110 is adhered to a top surface of the bottom plate 104, a cold cathode fluorescent lamp (CCFL) 114 used for providing light is installed in the interior of the rear cover 102 adjacent to an inner side of the side plate 106, and a lamp reflector 112 is installed close to the inner side of the side plate 106. The lamp reflector 112 is between the cold cathode fluorescent lamp 114 and the side plate 106 of the rear cover 102. A cross-sectional profile of the lamp reflector 112 is U-shaped, a bottom surface of the lamp reflector 112 stays close to the side plate 106, and two side surface of the lamp reflector 112 extend outward from two edges of the bottom surface of the lamp reflector 112 and straightly over the bottom plate 104 and the cold cathode fluorescent lamp 114, respectively.

[0006] A light guide plate 108 is installed over the reflective sheet 110 in the interior of the rear cover 102 and surrounded by the cold cathode fluorescent lamp 114. The light guide plate 108 is principally used for guiding the location light emission, to enhance the luminance of a panel and to maintain the illumination uniformity of panel. The reflective sheet 110 and the lamp reflector 112 are used to reflect or guide the light emitted by the cold cathode fluorescent lamp 114 to the light guide plate 108, so as to increase the efficiency of light use. A diffusion sheet 116 located on the light guide plate 108 is used to keep the distribution of the light emitted from the light guide plate 108 more uniform. Furthermore, a prism sheet (not shown) with a light-condensing property is set on the diffusion sheet 116 to increase the orientation of the emitting light, thereby achieving the objective of enhancing the front illumination of the panel. After the diffusion sheet 116 is set, mode frames 118 are installed on another edge of the side plate 106 to cover an upper side of the lamp reflector 112, a portion of the light guide plate 108 and a portion of the diffusion sheet 116.

[0007] The edge-type back light module is set with a reflective sheet and a lamp reflector, and the lamp reflector is expensive, comprising about 7% of the cost of the back light module, so that the lamp reflector becomes a burdensome cost in fabricating the back light module.

[0008] From the above, it seen that an improved display is highly desirable.

BRIEF SUMMARY OF THE INVENTION

[0009] According to the present invention, techniques related to a liquid crystal panels are included. More particularly, the present invention provides a back light module, and more particularly, to including an edge-type back light module for a liquid crystal panel. But it would be recognized that the invention has a much broader range of applicability.

[0010] In a specific embodiment, the present invention provides a back light module, in which a reflective sheet is set in the interior of a rear cover of the back light module, so that a lamp reflector can be replaced to reduce the cost of the back light module. Here, the term "back" does not have any special meaning with respect to gravity or other fixed reference point, but should be interpreted according to one of ordinary skill in the art.

[0011] Another embodiment of the present invention provides a back light module of a liquid crystal display device, in which a white reflective paint layer is coated on the interior of a metal rear cover and can replace the reflective sheet and the lamp reflector. Here, the term "rear" does not have any special meaning with respect to gravity or other fixed reference point, but should be interpreted according to one of ordinary skill in the art. Therefore, the cost of the back light module can be reduced greatly. Additionally, the reflective film is directly coated on the metal rear cover; the direct heat dissipating effect can thus be achieved by the metal rear cover to enhance substantially the heat dissipation efficiency of the back light module.

[0012] Still another embodiment of the present invention provides a back light module of a liquid crystal display device, in which a plurality of positioning sheets and a plurality of openings corresponding to the positioning sheets are set in a bottom plate of a metal rear cover, and a plurality

of slots with locations and sizes corresponding to the positioning sheets are set in a reflective sheet. Therefore, the reflective sheet can be effectively fixed on the bottom plate of the metal rear cover.

[0013] According to the aforementioned description, the present invention provides a back light module comprising: a rear cover, a reflective film and a high-reflective mode frame. The rear cover comprises a bottom plate and a side plate, and a first edge of the side plate is joined to an edge of the bottom plate. The reflective film is disposed on a top surface of the bottom plate and an inner side surface of the side plate. The high-reflective mode frame is set on a second edge of the side plate opposite the first edge.

[0014] According to a preferred embodiment of the present invention, a material of the reflective film is a white reflective paint layer with anti-yellowing and heat-resistant properties. The white reflective paint layer is coated on the interior of the rear cover, so a lamp reflector and a reflective sheet can be replaced to reduce greatly the cost of the back light module. As merely an example, the white reflective paint is manufactured by TAI YING PAINT INDUSTRIAL CO., LTD. and called PU 800 White, Product Number: T3U8W01, but other types of paint products and/or coatings can be used, depending upon the embodiment. Furthermore, the bottom plate of the rear cover is punched to form a plurality of positioning sheets protruding through the top surface of the bottom plate and to form a plurality of corresponding openings in the bottom plate. At least one of the positioning sheets is formed having a curve in at least one corner of the bottom plate, and a corner of the light guide plate corresponding to the at least one corner of the bottom plate having the curve has a cut breach, such as a triangle cut breach. Therefore, when the light guide plate is put into the interior of the rear cover, the collocation of the curved position sheet and the cut breach of the light guide plate can provide a foolproof function and can effectively fix the light guide plate. In addition, electrodes of the cold cathode fluorescent lamp can be set in a part of the openings for the heat dissipating benefit of the electrodes. Further, because it is not necessary to install a lamp reflector, a line assembling trace of the connecting lines may run through at least one opening in a top surface of the high-reflective mode frame on the back light module, thereby enhancing the convenience of assembling the connecting lines.

[0015] Various additional objects, features and advantages of the present invention can be more fully appreciated with reference to the detailed description and accompanying drawings that follow.

BRIEF DESCRIPTION OF THE DRAWINGS

[0016] The foregoing aspects and many of the attendant advantages of this invention will become more readily appreciated as the same becomes better understood by reference to the following detailed description, when taken in conjunction with the accompanying drawings, wherein:

[0017] FIG. 1 illustrates a cross-sectional view of a back light module of a conventional liquid crystal display device;

[0018] FIG. 2 illustrates a simplified cross-sectional view of a back light module in accordance with a preferred embodiment of the present invention;

[0019] FIG. 3 illustrates a simplified three-dimensional view of a back light module in accordance with another preferred embodiment of the present invention;

[0020] FIG. 4 illustrates a simplified three-dimensional diagram of a back light module in accordance with a preferred embodiment of the present invention;

[0021] FIG. 5 illustrates a simplified three-dimensional diagram of a back side of a rear cover of a back light module in accordance with a preferred embodiment of the present invention;

[0022] FIG. 6 illustrates a simplified top view of a back-side of a rear cover of a back light module in accordance with a preferred embodiment of the present invention; and

[0023] FIG. 7 illustrates a simplified diagram of a line assembling trace of connecting lines of a back light module in accordance with a preferred embodiment of the present invention.

DETAILED DESCRIPTION OF THE INVENTION

[0024] According to the present invention, techniques related to a liquid crystal panels are included. More particularly, the present invention provides a back light module, and more particularly, to including an edge-type back light module for a liquid crystal panel. But it would be recognized that the invention has a much broader range of applicability. In order to make the illustration of embodiments of the present invention more explicit and complete, the following description is stated with reference to FIG. 2 to FIG. 7.

[0025] A liquid crystal display device is typically composed of a panel, a back light module and a frame, in which the panel is located on the back light module, and the frame is located on the panel. After the frame is assembled with the back light module, the panel is fixed between the frame and the back light module to complete the basic structure of the liquid crystal display device.

[0026] Referring to FIG. 2, a cross-sectional view of a back light module in accordance with a preferred embodiment of the present invention is illustrated. This diagram is merely an example, which should not unduly limit the scope of the claims herein. One of ordinary skill in the art would recognize many variations, modifications, and alternatives. As shown, the back light module 200 is one of the key components of a liquid crystal display device, and the back light module 200 is mainly composed of a rear cover 202, a light guide plate 208, at least a cold cathode fluorescent lamp 212, a diffusion sheet 214 and a mode frame 216, and other elements. The rear cover 202 is preferably composed of a material with high thermal conductivity, such as metal, or other combination of materials that may include metals or metallic species. In a specific embodiment of the present invention, the material of the rear cover 202 can be galvanized steel plate, stainless steel plate, or aluminum plate, or multi-layered materials, or any combination of these. The rear cover 202 comprises a bottom plate 204 and a side plate 206, in which an edge of the side plate 206 is joined to an edge of the bottom plate 204, and another edge of the side plate 206 opposite the edge joined to the edge of the bottom plate 204 forms an opening of the rear cover 202, as shown in FIG. 4. A top surface of the bottom plate 204 of the rear cover 202 and an inner side surface of the side plate 206 are both covered with a reflective film 210. In the present invention, as shown in FIG. 2, a material of the reflective film 210 is preferably a white reflective paint layer covering

the top surface of the bottom plate **204** and the inner side surface of the side plate **206** by coating, and the reflective film **210** preferably has anti-yellowing and heat-resistant properties. In addition, the reflective film **210** can be a white reflective sheet covering the top surface of the bottom plate **204** and the inner side surface of the side plate **206** by putting, as shown in **FIG. 3**, where the reflective film **210** preferably has anti-yellowing and heat-resistant properties. In a preferred embodiment, the white reflective plate **206** can be stuck to cover the top surface of the bottom plate **204** and the inner side surface of the side plate **206** by using an adhesive material.

[0027] In a preferred embodiment of the present invention, when the reflective film **210** is a white reflective sheet, to achieve the objective of effectively fixing the reflective film **210**, position sheets **230** can be formed and protrude from the top surface of the bottom plate **204** by punching the bottom plate **204** of the rear cover **202**, as illustrated in **FIG. 4** to **FIG. 7**. Openings (not shown) with a size slightly larger than that of the side surfaces the position sheets **230** are set on the reflective film **210** corresponding to the position sheets **230**. Accordingly, when the sheet-like reflective film **210** is disposed in the interior of the rear cover **202**, the positioning sheets **230** can be inserted into the openings of the reflective film **210**, so that the location of the reflective film **210** can be effectively fixed in the bottom plate **204** to prevent the reflective film **210** from shifting caused by slipping. Furthermore, referring to **FIG. 4**, a plurality of positioning bumps **220** can be set in the side plate **206** of the rear cover **202**. In forming the positioning bumps **220**, the side plate **206** is punched from the outer side of the side plate **206** to the inner side to form a plurality of punching holes **218**, so that the positioning bumps **220** corresponding to the punching holes **218** and spreading outwardly are formed on the inner side surface of the side plate **206**. A plurality of fixing holes **238** with a size slightly smaller than that of the positioning bumps **220** are set at the positions, which correspond to the positions of the positioning bumps **220**, in the sheet-like reflective film **210**. Accordingly, when the sheet-like reflective film **210** is installed into the interior of the rear cover **202**, the positioning holes **238** in the reflective film **210** can be inserted by the corresponding position bumps **220**, and then the positioning bumps **220** spreading outwardly are used to fix the side portions of the reflective film **210** on the inner side surface of the side plate **206**.

[0028] In a preferred embodiment of the present invention, a plurality of positioning sheets **230** may be set in the bottom plate **204**, where a part of the positioning sheets **230** may be located in at least one corner, and preferably two opposite corners, and the positioning sheets **230** in the corners are formed with curves **228**, such as arched curves, as illustrated in **FIG. 4**. Each of the curves **228** is formed by at least one of the positioning sheets **230**.

[0029] In addition, the light guide plate **208** is disposed on the reflective film **210** in the interior of the rear cover **202**, and in the light guide plate **208**, which corners corresponding to the corners of the bottom plate **204** having the positioning sheets **230** with the curves **228** can be respectively set with a cut breach **226**, such as a triangle cut breach. Thus, each corner of the light guide plate **208** having the cut breach **226** can be smoothly disposed into the corner of the bottom plate **204** having the positioning sheet **230** with the curve **228**. The corners of the light guide plate **208** having

cut breaches **226** and the corners of the bottom plate **230** having the positioning sheets **230** with the curves **228** constitute a foolproof design for installing the light guide plate **208**. For example, when the corner of the light guide plate **208** is formed in a right angle, the right-angled corner of the light guide plate **208** cannot be disposed into the corner of the bottom plate **204** having the positioning sheet **230** with the curve **228**, such as an arched curve, due to the restriction of the positioning sheet **230** with the curve **228**.

[0030] After the bottom plate **204** is punched to form the positioning sheets **230** on the top surface of the bottom plate **204**, openings **232** are formed at the places, which are relating to the positioning sheets **230**, in the bottom plate **204**. The sizes are the same with those of the relating positioning sheets **230**. The cold cathode fluorescent lamp **212** is installed surrounding the inner side surface of the side plate **206** of the rear cover **202**, and the cold cathode fluorescent lamp **212** is located between the sides of the light guide plate **208** and the side parts of the reflective film **210**. The cold cathode fluorescent lamp **212** can be a single or multiple lamp design. Further, the cold cathode fluorescent lamp **212** can be a rectilinear lamp or an L-shaped lamp, among others. The cold cathode fluorescent lamp **212** includes two sets of electrodes **222** and **224** with opposite polarities. The locations of the openings **232** are preferably at the corners of the rear cover **202** and corresponding to those of the electrodes **222** and **224**. When the back light module **200** is operating, the electrodes **222** and **224** induce more waste heat, so it is easier for the electrodes **222** and **224** to dissipate heat by installing the electrodes **222** and **224** in the openings **232** of the rear cover **202**, thereby greatly increasing the heat-dissipating efficiency of the electrodes **222** and **224**. Moreover, in order to prevent the cold cathode fluorescent lamp **212** from slipping, the cold cathode fluorescent lamp **212** may be equipped with at least one lamp fixed support to fix the cold cathode fluorescent lamp **212**.

[0031] The diffusion sheet **214** is flatly disposed on the light guide plate **208**, and a plurality of slots are set at the places, which are corresponding to the locations of the positioning sheets **230**, in the diffusion sheet **214**, so that the location of the diffusion sheet **214** can be effectively fixed on the light guide plate **208**, to prevent the diffusion sheet **214** from shifting caused by slipping. The mode frame **216** is installed on the edge of the side plate **206** forming the opening. The mode frame **216** extends toward the inside of the rear cover **202**, and the mode frame **216** covers the space between the light guide plate **208** and the side plate **206**, the whole cold cathode fluorescent lamp **212**, and the rim of the light guide plate **208** and the rim of the diffusion sheet **214**. In the present invention, the mode frame **216** is composed of a high-reflective material, such as polycarbonate (PC), although other materials may be used.

[0032] In a specific embodiment of the present invention, includes by way of coating or putting of the reflective film **210** on the top surface of the bottom plate **204** and the inner side surface of the side plate **206** in the rear cover **202**, and use of the high-reflective mode frame **216**, the light emitted by the cold cathode fluorescent lamp **212** can be successfully reflected, so the conventional lamp reflector can be replaced. In the preferred embodiment of the present invention, by coating a white reflective paint on the top surface of the bottom plate **204** and the inner side surface of the side plate **206** in the rear cover **202** as the reflective film **210** and using

the high-reflective mode frame **216**, the cost of the back light module **200** can be reduced by about 11% to 13% according to a specific embodiment. Further, because the heat can be directly transmitted to the rear cover **202** coated by the white reflective paint, and the rear cover **202** is composed of the material with high thermal conductivity, the heat-dissipating efficiency of the back light module **200** can be effectively enhanced.

[0033] Referring to **FIG. 5** and **FIG. 6**, the bottom plate **204** of the rear cover **202** can comprise a plurality of bosses **234** protruding from the backside surface of the bottom plate **204** according to the need of the device. Outer devices, such as an AD board, an inverter and a hinge, can be screwed and fixed on the bottom plate **204** of the rear cover **202**, such as an AD board locking site **244**, an inverter locking site **246** and a hinge locking site **248**, by the bosses **234** and a plurality of locking elements, such as screws. The surfaces of the bosses **234** joined to the bottom plate **204** are coated with white reflective films to prevent light leakage.

[0034] Referring to **FIG. 7**, the cold cathode fluorescent lamp **212** further comprises a plurality of connecting lines **236**, and a line assembling trace of the connecting lines **236** preferably runs through a top surface of the high-reflective mode frame **216** on the back light module **200**. A plurality of fillisters are set on the top surface of the mode frame **216** by injection molding, for a benefit of assembling the connecting lines **236** of the cold cathode fluorescent lamp **212**, as shown in **FIG. 2**, **FIG. 3** and **FIG. 7**. In the preferred embodiment of the present invention, the top surface of the mode frame **216** further includes at least one opening **242** through which the connecting lines **236** to facilitate line-assembling, as shown in **FIG. 7**.

[0035] According to the aforementioned description, an advantage of the present invention is that by setting a reflective sheet in the interior of a rear cover of a back light module, a lamp reflector of a conventional back light module can be replaced to reduce a cost of the back light module.

[0036] According to the aforementioned description, another advantage of the present invention is that by coating white reflective paint film on the interior of a metal rear cover of a back light module as a reflective film, a reflective sheet and a lamp reflector in a conventional back light module can be replaced. Therefore, the cost of the back light module can be reduced greatly. Additionally, the reflective film is directly coated on the rear cover composed of the material with high thermal conductivity; thus the direct heat dissipating effect can be achieved by the rear cover with high thermal conductivity to enhance substantially the heat dissipation efficiency of the back light module.

[0037] According to the aforementioned description, still another advantage of the present invention is that a plurality of positioning sheets and a plurality of openings corresponding to the positioning sheets are set in a bottom plate of a rear cover, and a plurality of slots with locations and sizes corresponding to the positioning sheets are set in a reflective sheet. Therefore, the reflective sheet can be effectively fixed on the bottom plate of the metal rear cover.

[0038] As is understood by a person skilled in the art, the foregoing preferred embodiments of the present invention are illustrative of the present invention rather than limiting of the present invention. It is intended to cover various

modifications and similar arrangements be included within the spirit and scope of the appended claims, the scope of which should be accorded the broadest interpretation so as to encompass all such modifications and similar structures.

What is claimed is:

1. A back light module for a display panel, comprising:
 - a rear cover, the rear cover comprising a bottom plate and a side plate coupled to the bottom plane, the side plate having a first edge region, a second edge region, and an inner side surface, the first edge region being coupled to the bottom plate, the bottom plate comprising an edge region and a top surface, the edge region being joined to the first edge region of the side plate;
 - a reflective film disposed overlaying the top surface of the bottom plate and the inner side surface of the side plate; and
 - a reflective mode frame set on the second edge region of the side plate opposite the first edge region.
2. The back light module according to claim 1, wherein the rear cover is substantially a metal bearing material.
3. The back light module according to claim 1, wherein the rear cover is made of a material selected from the group consisting of galvanized steel plate, stainless steel plate, and aluminum plate.
4. The back light module according to claim 1, wherein the reflective film comprises a white reflective paint layer coated on the rear cover.
5. The back light module according to claim 1, wherein the reflective film comprises a white reflective sheet.
6. The back light module according to claim 5, wherein the bottom plate of the rear cover includes at least one positioning sheet protruding from the top surface of the bottom plate, and the reflective film is set within at least one slot corresponding to the at least one positioning sheet.
7. The back light module according to claim 6, further comprising a light guide plate disposed on the reflective film on the bottom plate.
8. The back light module according to claim 7, further comprising a diffusion sheet on the light guide plate, and a plurality of slots corresponding to the at least one positioning sheet provided by the diffusion sheet.
9. The back light module according to claim 7, wherein the light guide plate comprises at least one corner, the at least one corner has a cut breach, at least one corner of the bottom plate of the rear cover corresponding to the at least one corner of the light guide plate has at least one positioning sheet with a curve protruding from the top surface of the bottom plate, and the cut breach of the at least one corner of the light guide plate is coupled to the at least one positioning sheet in the at least one corner of the bottom plate.
10. The back light module according to claim 9, wherein the bottom plate of the rear cover comprises a plurality of openings, the plurality of openings comprising respective locations and sizes, each of the openings corresponding to the at least one positioning sheet of the bottom plate.
11. The back light module according to claim 10, further comprising a cold cathode fluorescent lamp surrounding the inner side surface of the side plate of the rear cover, wherein the cold cathode fluorescent lamp includes two electrodes, and the electrodes are located in a part of the openings.
12. The back light module according to claim 1, wherein the inner side surface of the side plate of the rear cover

comprises a plurality of positioning bumps, a plurality of positioning holes, corresponding to the positioning bumps, are set in the reflective film, and the positioning bumps are inserted into the corresponding positioning holes to maintain the reflective film to the inner side surface of the side plate of the rear cover.

13. The back light module according to claim 1, wherein the reflective film comprises a white reflective sheet characterized by an anti-yellowing and heat-resistant properties.

14. The back light module according to claim 1, further includes at least one L-shaped cold cathode fluorescent lamp surrounding the inner side surface of the side plate of the rear cover.

15. The back light module according to claim 1, wherein the rear cover comprises a lower surface, the lower surface comprising a plurality of bosses, and surfaces of the bosses joined with the rear cover are coated with white reflective films.

16. The back light module according to claim 15, wherein the bosses, the rear cover and a plurality of outer devices are screwed altogether, and the outer devices comprises an AD board, an inverter and a hinge.

17. A liquid crystal display device, comprising:

a back light module, comprising:

a rear cover, the rear cover comprising a bottom plate and a side plate coupled to the bottom plane, the side plate having a first edge region, a second edge region, and an inner side surface, the first edge region being coupled to the bottom plate, the bottom plate comprising an edge region and a top surface, the edge region being joined to the first edge region of the side plate;

a reflective film disposed overlaying the top surface of the bottom plate and the inner side surface of the side plate; and

a reflective mode frame set on the second edge region of the side plate opposite the first edge region;

a panel coupled to the back light module; and

a frame coupled to the panel, the frame being associated with the back light module to maintain the panel between the frame and the back light module.

18. The liquid crystal display device according to claim 17, wherein a material of the reflective film is a white reflective paint layer coated on the rear cover.

19. The liquid crystal display device according to claim 17, wherein a material of the reflective film is a white reflective sheet.

20. A method for assembling a liquid crystal display device, comprising:

providing a back light module, comprising:

a rear cover, the rear cover comprising a bottom plate and a side plate coupled to the bottom plane, the side plate having a first edge region, a second edge region, and an inner side surface, the first edge region being coupled to the bottom plate, the bottom plate comprising an edge region and a top surface, the edge region being joined to the first edge region of the side plate;

a reflective film disposed overlaying the top surface of the bottom plate and the inner side surface of the side plate; and

a reflective mode frame set on the second edge region of the side plate opposite the first edge region;

coupling a panel to the back light module; and

coupling a frame to the panel, the frame being associated with the back light module to maintain the panel between the frame and the back light module.

* * * * *

专利名称(译)	背光模块和液晶面板系统		
公开(公告)号	US20050265048A1	公开(公告)日	2005-12-01
申请号	US11/123847	申请日	2005-05-06
[标]申请(专利权)人(译)	群创光电股份有限公司		
申请(专利权)人(译)	奇美电子股份有限公司.		
当前申请(专利权)人(译)	群创光电		
[标]发明人	WANG TZUCHANG HONG SHUNTA		
发明人	WANG, TZUCHANG HONG, SHUNTA		
IPC分类号	G02F1/13357 F21V8/00 F21V29/00 F21Y103/00 G02F1/1335		
CPC分类号	G02B6/0055 G02B6/0031		
优先权	093113243 2004-05-11 TW		
其他公开文献	US7371002		
外部链接	Espacenet USPTO		

摘要(译)

一种用于液晶显示器的背光模块。该模块具有后盖，反射膜和高反射模式框架。后盖有底板和侧板；侧板的第一侧连接到底板的一侧。反射膜设置在底板的顶表面和内侧表面上，以代替灯反射器。高反射模式框架放在第二侧，第二侧与侧板的第一侧相对。

