



US 20060012743A1

(19) **United States**

(12) **Patent Application Publication**

Yun et al.

(10) **Pub. No.: US 2006/0012743 A1**

(43) **Pub. Date: Jan. 19, 2006**

(54) **LIQUID CRYSTAL DISPLAY**

(30) **Foreign Application Priority Data**

(76) Inventors: **Sai Chang Yun, Kumi-shi (KR); Hong Sung Song, Kumi-shi (KR)**

Apr. 20, 2002 (KR) 2002-21794

Publication Classification

Correspondence Address:
MCKENNA LONG & ALDRIDGE LLP
1900 K STREET, NW
WASHINGTON, DC 20006 (US)

(51) **Int. Cl.**
G02F 1/1345 (2006.01)

(52) **U.S. Cl.** 349/149

(21) Appl. No.: **11/229,619**

(57) **ABSTRACT**

(22) Filed: **Sep. 20, 2005**

A liquid crystal display includes driver integrated circuits for applying a video signal to data lines, output pins and at least one dummy output pin are arranged within each data driver integrated circuit, and a switching pin is arranged within each data driver integrated circuit for controlling whether or not the dummy output pin outputs a signal.

Related U.S. Application Data

(62) Division of application No. 10/318,023, filed on Dec. 13, 2002.

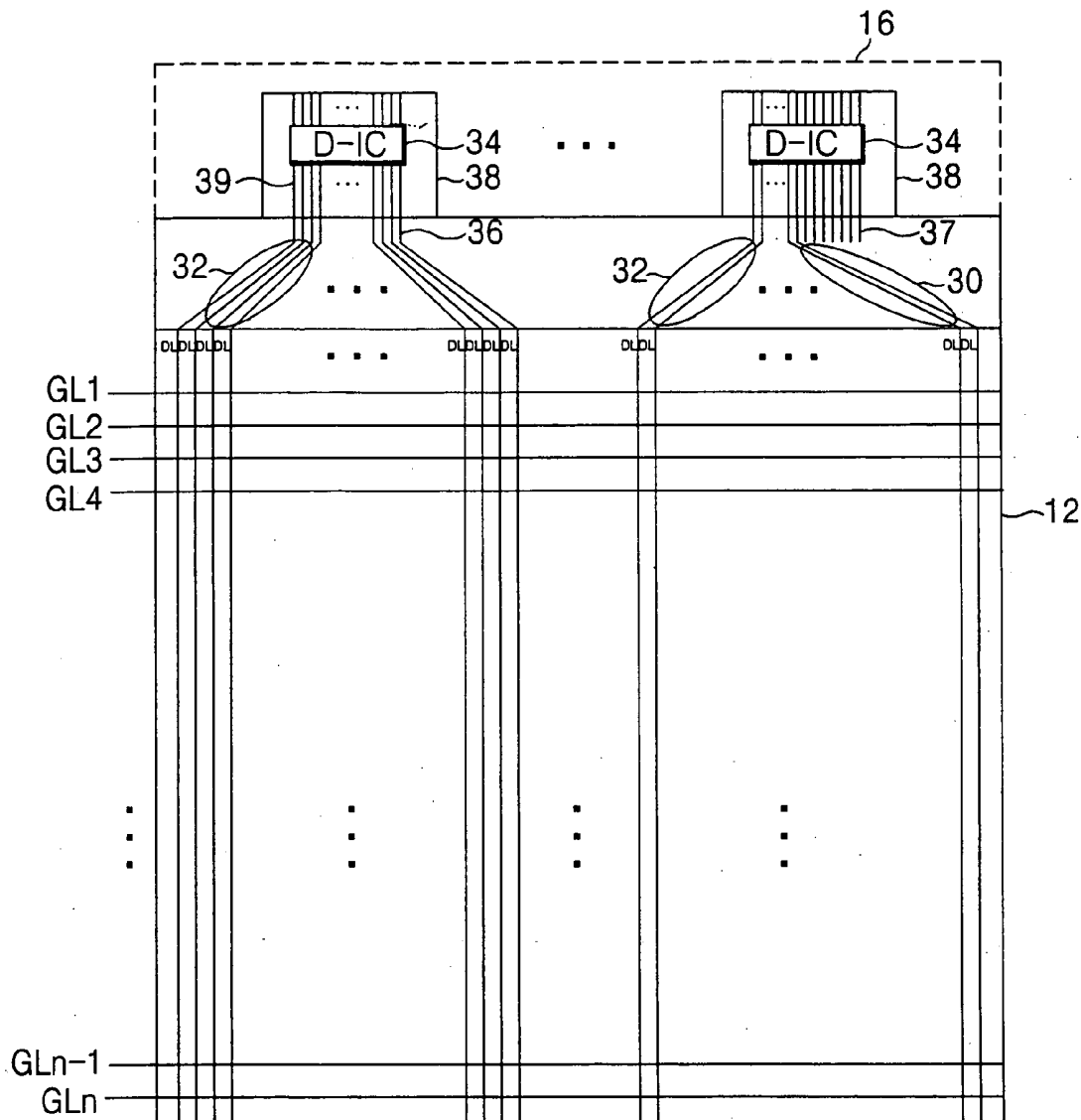

FIG. 1
RELATED ART

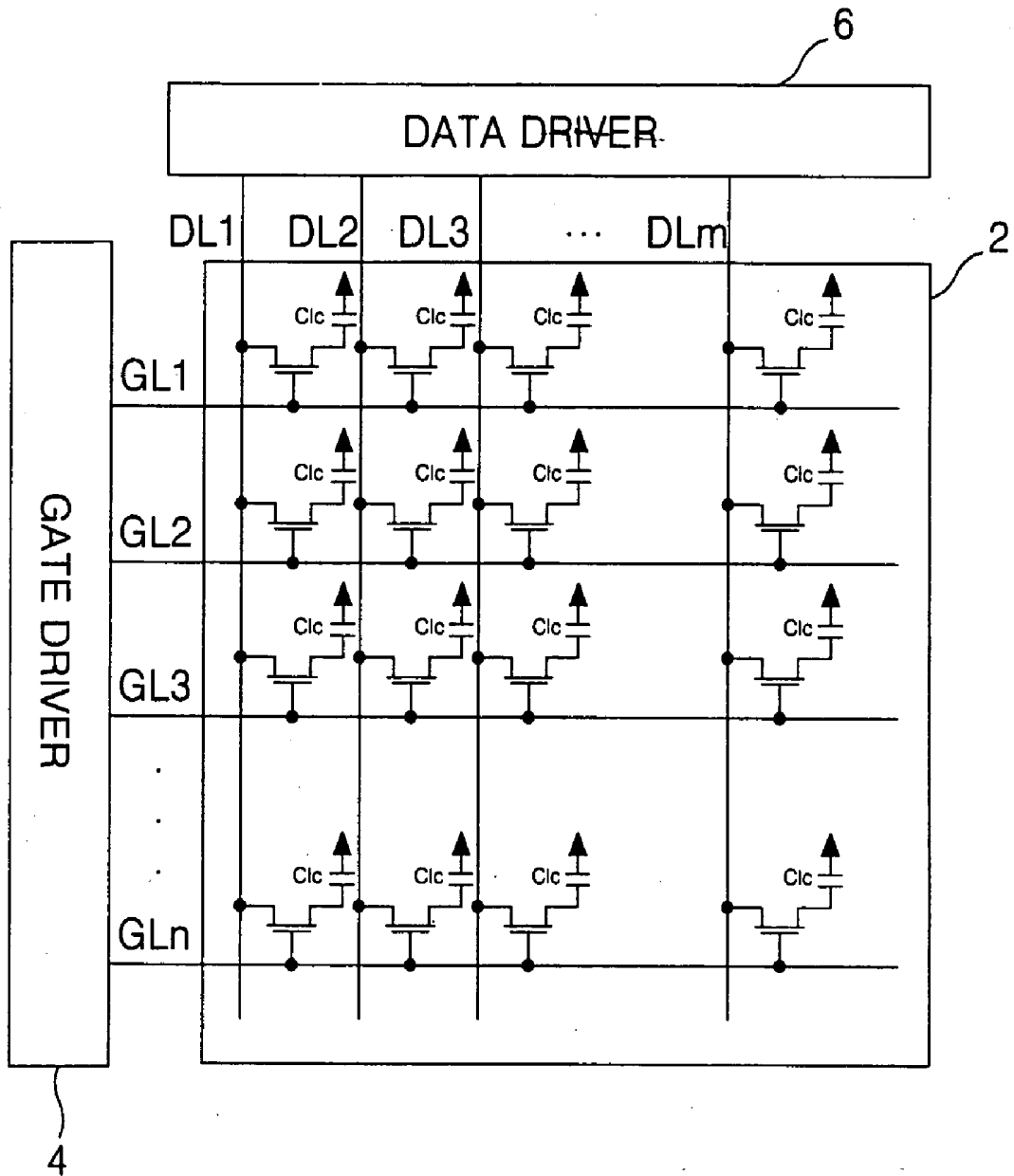

FIG. 2A
RELATED ART

+	+	+	+	+	+	+	+
-	-	-	-	-	-	-	-
+	+	+	+	+	+	+	+
-	-	-	-	-	-	-	-
+	+	+	+	+	+	+	+
-	-	-	-	-	-	-	-
+	+	+	+	+	+	+	+
-	-	-	-	-	-	-	-

FIG. 2B
RELATED ART

-	-	-	-	-	-	-	-
+	+	+	+	+	+	+	+
-	-	-	-	-	-	-	-
+	+	+	+	+	+	+	+
-	-	-	-	-	-	-	-
+	+	+	+	+	+	+	+
-	-	-	-	-	-	-	-
+	+	+	+	+	+	+	+

FIG. 4A
RELATED ART

+	-	+	-	+	-	+	-
-	+	-	+	-	+	-	+
+	-	+	-	+	-	+	-
-	+	-	+	-	+	-	+
+	-	+	-	+	-	+	-
-	+	-	+	-	+	-	+
+	-	+	-	+	-	+	-
-	+	-	+	-	+	-	+

FIG. 4B
RELATED ART

-	+	-	+	-	+	-	+
+	-	+	-	+	-	+	-
-	+	-	+	-	+	-	+
+	-	+	-	+	-	+	-
-	+	-	+	-	+	-	+
+	-	+	-	+	-	+	-
-	+	-	+	-	+	-	+
+	-	+	-	+	-	+	-

FIG. 5

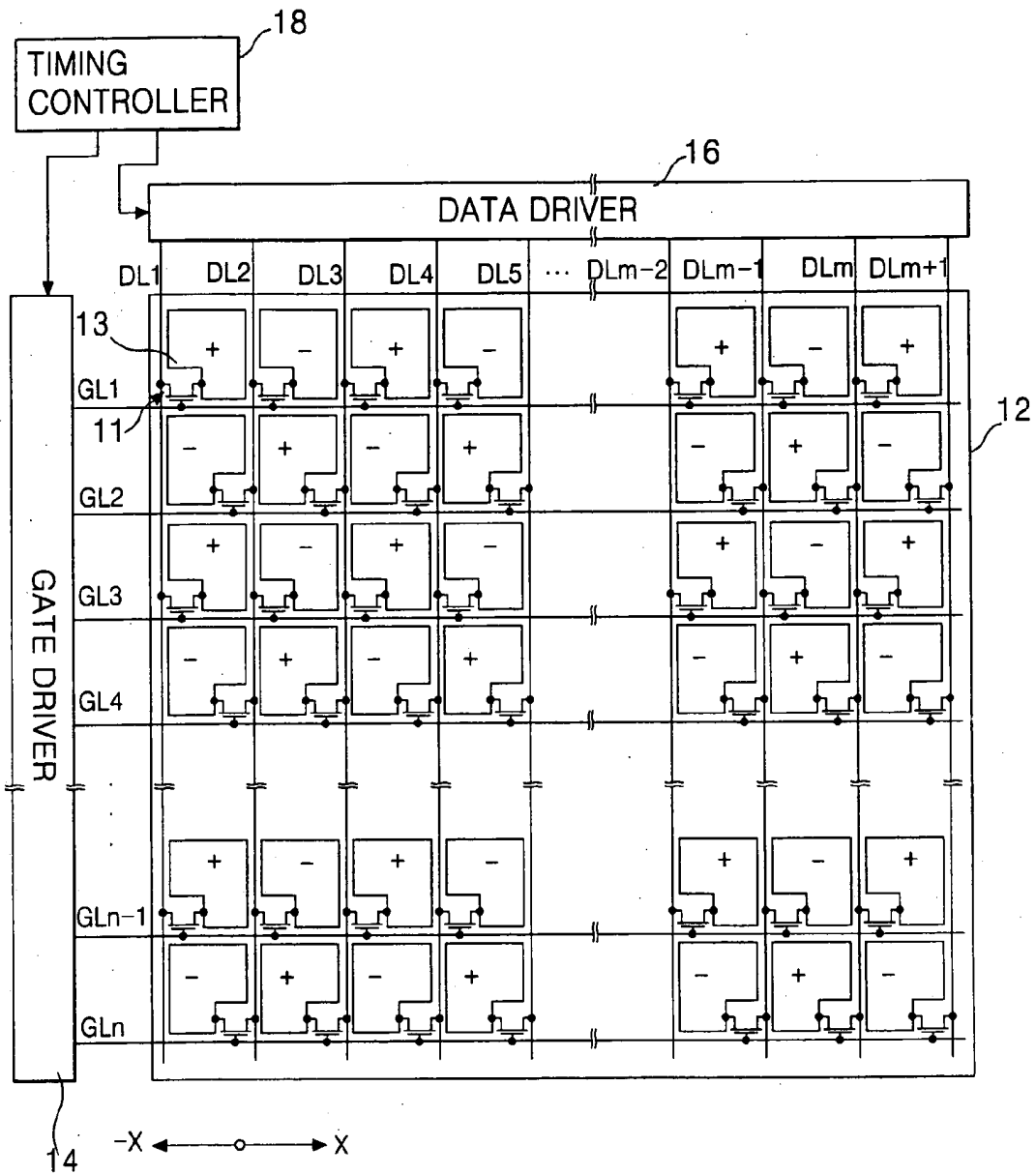
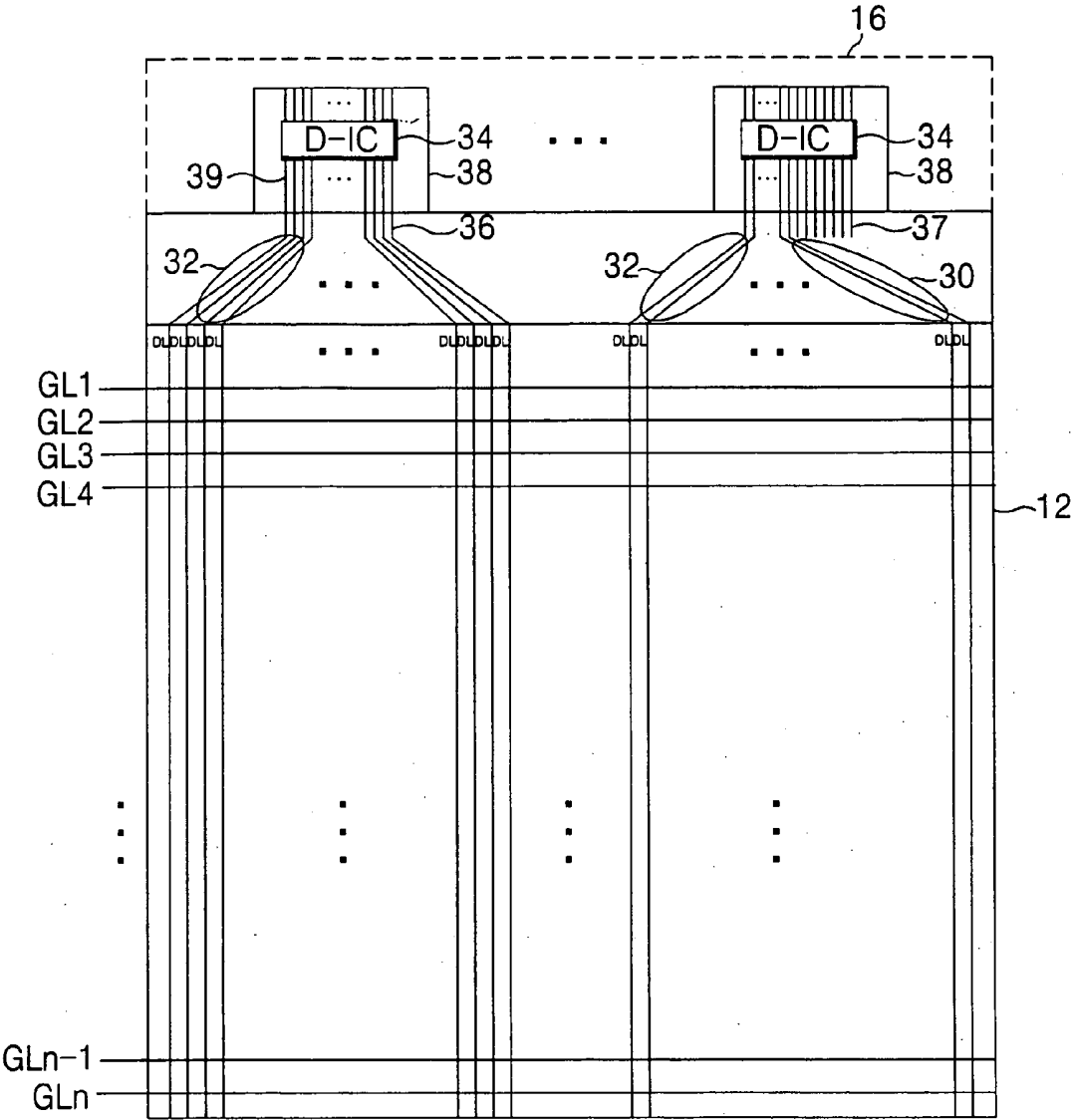

FIG. 6



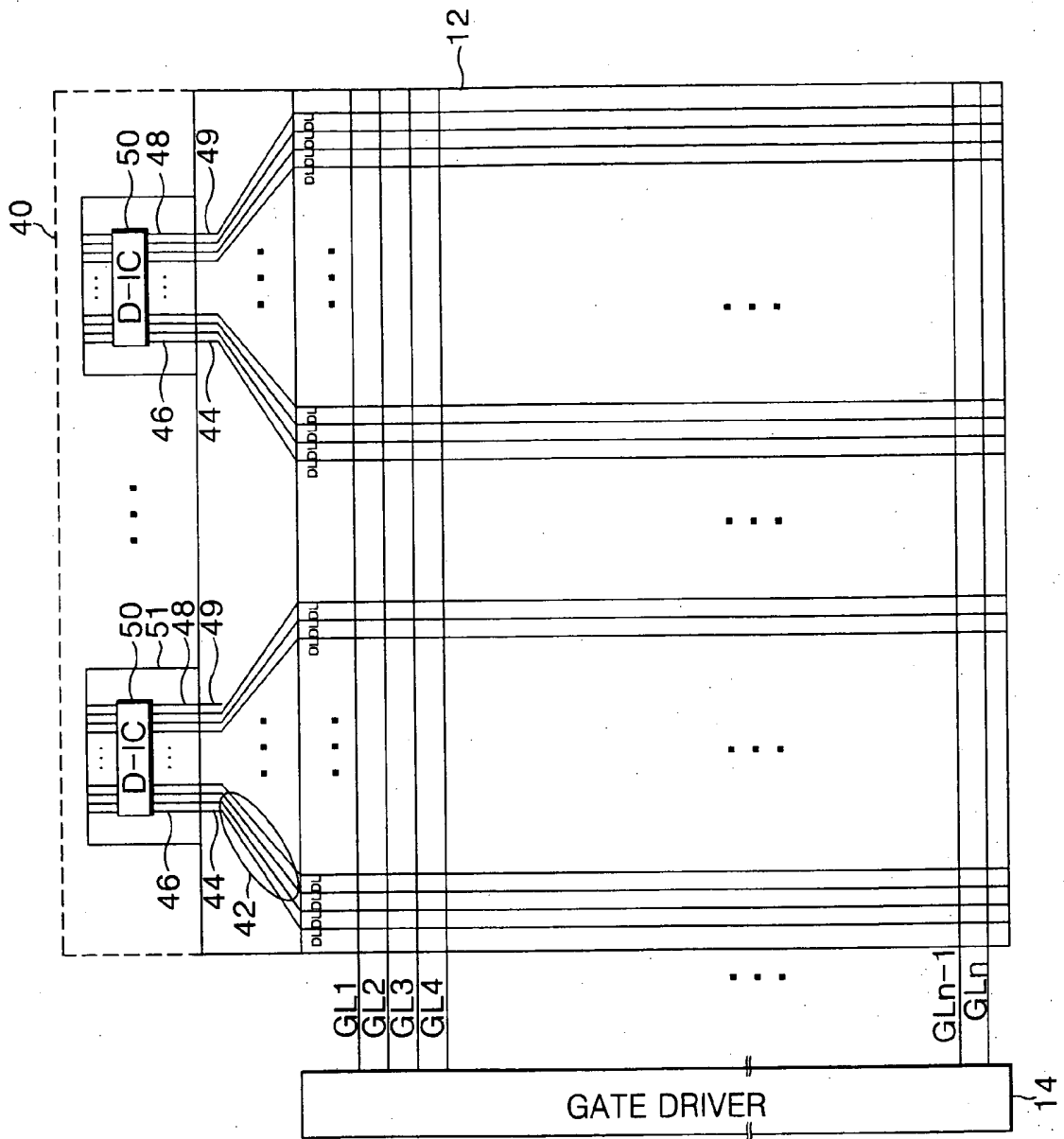

FIG. 7

LIQUID CRYSTAL DISPLAY

[0001] This application claims the benefit of Korean Patent Application No. 2002-21794, filed on Apr. 20, 2002, which is hereby incorporated by reference for all purposes as if fully set forth herein.

BACKGROUND OF THE INVENTION

[0002] 1. Field of the Invention

[0003] This present invention relates to a liquid crystal display, and more particularly to a liquid crystal display driven according to a dot inversion method using a data driver driven according to a column inversion method, wherein a short circuit of a link is prevented.

[0004] 2. Description of the Related Art

[0005] Generally, liquid crystal displays typically include a liquid crystal display panel having a plurality of liquid crystal cells arranged in a matrix pattern and driving circuit for driving the liquid crystal display panel. To display pictures, liquid crystal displays control light transmittance characteristics of the liquid crystal cells in accordance with inputted video signals.

[0006] The liquid crystal cells are located at areas defined by crossings of gate lines and data lines. Each the liquid crystal cell is provided with a common electrode and a pixel electrode with which an electric field may be generated. Each pixel electrode is connected to a corresponding data line via a switching device such as a thin film transistor (TFT). A terminal of a TFT is connected to a gate line such that video signals may be applied to corresponding pixel electrodes. The driving circuit includes a gate driver for driving gate lines, a data driver for driving data lines, and a common voltage generator for driving the common electrode.

[0007] The gate driver sequentially scans the gate lines of the liquid crystal display panel, supplies gate signals to gate lines, and drives the liquid crystal cells on the liquid crystal display panel one gate line at a time. Whenever a gate signal is supplied to a gate line, the data driver supplies suitable video signals to each of data lines crossing that scanned gate line while the common voltage generator supplies common voltage signals to the common electrode. Depending on the video signal applied to the data line, an orientation of molecules of liquid crystal material provided within the liquid crystal cell, between the pixel and common electrodes, may be altered and the light transmittance of the liquid crystal cell may be controlled. Accordingly, as the light transmittances of each of the liquid crystal cells in the liquid crystal display panel are individually controlled, the liquid crystal display panel may display a picture.

[0008] FIG. 1 illustrates a schematic view of a related art liquid crystal display.

[0009] Referring to FIG. 1, liquid crystal displays typically include a liquid crystal display panel 2 having a plurality of liquid crystal cells arranged in a matrix pattern, a gate driver 4 for driving gate lines GL1 to GLn arranged in the liquid crystal display panel 2, and a data driver 6 for driving data lines DL1 to DLm also arranged in the liquid crystal display panel 2.

[0010] Each of the liquid crystal cells includes a TFT that responds to gate signals applied to the gate lines GL1 to GLn

by supplying video signals, applied to the data lines DL1 to DLm, to the liquid crystal cells. Each liquid crystal cell can be represented as a pixel electrode and a common electrode connected to each other via a TFT and a liquid crystal capacitor Clc. A storage capacitor (not shown), for maintaining a voltage of the video signal, is included within the liquid crystal cell. The storage capacitor maintains the charge within liquid crystal capacitor Clc until the next video signal is supplied.

[0011] Storage capacitors of liquid crystal cells are formed between preceding gate electrodes and pixel electrodes of each liquid crystal cell. The gate driver 4 sequentially applies gate signals to gate lines GL1 to GLn to drive the corresponding TFTs. The data driver 6 converts inputted video data into analog video signals and supplies analog video signals, specific to the scanned gate line, to the data lines DL1 to DLm during the period when the gate signal is supplied to the scanned gate line. Additionally, the data driver 6 converts inputted video data into liquid crystal cells by the column inversion method, however, is disadvantageous in that a flicker phenomenon is induced in vertical lines due to electrical cross-talk between liquid crystal cells arranged along the data lines.

[0012] Referring to FIGS. 4A and 4B, when driven according to the dot inversion method, the polarity of a video signal supplied to a liquid crystal cell is opposite the polarity of video signals supplied to adjacent liquid crystal cells (e.g., liquid crystal cells connected to adjacent gate and data lines). Further, the polarities of the video signals applied to the liquid crystal cells are inverted every frame. Driving liquid crystal cells by the dot inversion method offsets any flicker phenomenon that may be induced between vertically or horizontally adjacent liquid crystal cells. Accordingly, pictures generated by the liquid crystal display panel driven using the dot inversion method have superior qualities over pictures generated by liquid crystal display panels driven using other inversion methods.

[0013] Use of the dot inversion method, however, is disadvantageous in that the polarity of video signals supplied from the data driver to the data line need to be inverted in horizontal and vertical directions and individual pixel voltages required by the dot inversion method are typically greater than those required by other inversion methods. Accordingly, liquid crystal displays driven using a dot inversion method typically consume a relatively large amount of power during their operation.

SUMMARY OF THE INVENTION

[0014] Accordingly, the present invention is directed to a liquid crystal display that substantially obviates one or more of the problems due to limitations and disadvantages of the related art.

[0015] An advantage of the present invention provides a liquid crystal display driven by a dot inversion method using a data driver driven by a column inversion method, wherein such a liquid crystal display is capable of consuming a relatively small amount of power during its operation.

[0016] Additional features and advantages of the invention will be set forth in the description which follows, and in part will be apparent from the description, or may be learned by practice of the invention. These and other advan-

tages of the invention will be realized and attained by the structure particularly pointed out in the written description and claims hereof as well as the appended drawings.

[0017] To achieve these and other advantages and in accordance with the purpose of the present invention, as embodied and broadly described, a liquid crystal display device may include data driver including driver integrated circuits for applying video signals to the data lines, a plurality of output pins and at least one dummy output pin arranged within each driver integrated circuit, and a switching pin arranged within each driver integrated circuit for controlling whether or not the dummy output pin outputs a video signal.

[0018] In one aspect of the present invention, only one dummy output pin is arranged within each of the driver integrated circuits.

[0019] In another aspect of the present invention, only one dummy output pin may output a video signal.

[0020] In yet another aspect of the present invention, only the dummy output pin arranged within the driver integrated circuit applying a driving signal to the first data line may output the video signal.

[0021] In still another aspect of the present invention, only the dummy output pin arranged within the driver integrated circuit applying a driving signal to last data line may output the video signal.

[0022] According to the principles of the present invention, the liquid crystal display may further include tape carrier packages, wherein each of the driver integrated circuits may be mounted to a respective tape carrier package, tape carrier package pads connected to respective ones of the output pins, a dummy tape carrier package pad connected to a dummy output pin, data pads connected to the tape carrier package pads, a dummy data pad connected to the dummy tape carrier package pad, and links for electrically connecting the data pads to respective ones of the data lines.

[0023] In one aspect of the present invention, only one dummy data pad is connected to a link.

[0024] In another aspect of the present invention, a driving signal may be applied from a driver integrated circuit to the first data line via a dummy data pad.

[0025] In yet another aspect of the present invention, a driving signal may be applied from a driver integrated circuit to the last data line via a dummy data pad.

[0026] It is to be understood that both the foregoing general description and the following detailed description are exemplary and explanatory and are intended to provide further explanation of the invention as claimed.

BRIEF DESCRIPTION OF THE DRAWINGS

[0027] The accompanying drawings, which are included to provide a further understanding of the invention and are incorporated in and constitute a part of this specification, illustrate embodiments of the invention and together with the description serve to explain the principles of the invention.

[0028] In the drawings:

[0029] **FIG. 1** illustrates a schematic view of a related art liquid crystal display;

[0030] **FIGS. 2A and 2B** illustrate a line inversion method of driving a liquid crystal display;

[0031] **FIGS. 3A and 3B** illustrate a column inversion method of driving a liquid crystal display;

[0032] **FIGS. 4A and 4B** illustrate a dot inversion method of driving a liquid crystal display;

[0033] **FIG. 5** illustrates a schematic view of a liquid crystal display according to a first aspect of the present invention;

[0034] **FIG. 6** illustrates a schematic view of driver integrated circuits arranged within the data driver shown in **FIG. 5**; and

[0035] **FIG. 7** illustrates a schematic view of driver integrated circuits arranged within a data driver according to a second aspect of the present invention.

DETAILED DESCRIPTION OF THE ILLUSTRATED EMBODIMENTS

[0036] Reference will now be made in detail to embodiments of the present invention, examples of which are illustrated in the accompanying drawings.

[0037] **FIG. 5** illustrates a schematic view of a liquid crystal display according to a first aspect of the present invention.

[0038] Referring to **FIG. 5**, a liquid crystal display may, for example, include a liquid crystal display panel **12** having a plurality of liquid crystal cells arranged in a matrix pattern, a gate driver **14** for driving gate lines GL1 to GLn arranged in the liquid crystal display panel **12**, a data driver **16** for driving data lines DL1 to DLm+1 also arranged in the liquid crystal display panel **12**, and a timing controller **18** for controlling the gate and data drivers **14** and **16**, respectively. analog video signals using gamma voltages supplied from a gamma voltage generator (not shown).

[0039] Liquid crystal cells within liquid crystal display panels such as those illustrated in **FIG. 1** may be driven according to various inversion methods including frame, line, column, and dot inversion methods.

[0040] When driven according to the frame inversion method, the polarity of video signals supplied to the liquid crystal cells is inverted every frame.

[0041] Referring to **FIGS. 2A and 2B**, when driven according to the line inversion method, the polarity of video signals supplied to liquid crystal cells connected to a gate line is opposite the polarity of video signals supplied to liquid crystal cells connected to gate lines adjacent that gate line. Further, the polarities of the video signals applied to the liquid crystal cells are inverted every frame. Driving liquid crystal cells by the line inversion method, however, is disadvantageous in that a flicker phenomenon is induced in horizontal lines due to electrical cross-talk between liquid crystal cells arranged along the gate lines.

[0042] Referring to **FIGS. 3A and 3B**, when driven according to the column inversion method, the polarity of video signals supplied to liquid crystal cells connected to a data line is opposite the polarity of video signals supplied to

liquid crystal cells connected to data lines adjacent that data line. Further, the polarities of the video signals applied to the liquid crystal cells are inverted every frame. Driving

[0043] In one aspect of the present invention, a plurality of gate lines GL1 to GLn and a plurality of data lines DL1 to DLm+1 may be insulated from each other where they cross in the liquid crystal display panel 12. The liquid crystal cells, arranged in a matrix pattern, are provided at every crossing of the gate lines GL1 to GLn and the data lines DL1 to DLm+1. Each liquid crystal cell may include a thin film transistor (TFT) 11 connected to one of gate lines GL1 to GLn and a corresponding one of data lines DL1 to DLm+1.

[0044] Still referring to FIG. 5, liquid crystal cells consecutively arranged within a column may include TFTs 11 that are alternately connected left and right adjacent data lines DL. For example, liquid crystal cells arranged in odd numbered horizontal lines (e.g., liquid crystal cells including TFTs 11 connected to odd numbered gate lines GL1, GL3, GL5, etc.) may be connected to the first to mth data lines DL1 to DLm arranged in a -X axis direction with respect to a terminal connecting the TFT 11 to the gate line GL. Liquid crystal cells of even numbered horizontal lines (e.g., liquid crystal cells including TFTs 11 connected to even numbered gate lines GL2, GL4, GL6, etc.) may be connected to the second to (m+1)th data lines DL2 to DLm+1 arranged in a +X axis direction with respect to a terminal connecting the TFT 11 to the gate line GL.

[0045] The TFTs 11 respond to gate signals applied to gate lines GL1 to GLn by supplying video signals, applied to the data lines DL1 to DLm+1, to the liquid crystal cells. Depending on the video signal applied to the data line, an orientation of liquid crystal molecules (not shown) included within the liquid crystal cell, between a common electrode (not shown) and a pixel electrode 13, may be altered and the light transmittance of the liquid crystal cell may thereby be controlled. Accordingly, as the light transmittances of each of the liquid crystal cells in the liquid crystal display panel are individually controlled, the liquid crystal display panel may display a picture.

[0046] The gate driver 14 scans and sequentially applies gate signals to the gate lines GL1 to GLn to drive the corresponding TFTs 11. The data driver 16 converts inputted video data into analog video signals and supplies analog video signals, specific to the scanned gate line, to the data lines DL1 to DLm+1 during the period when the gate signal is supplied to the scanned gate line. Additionally, the data driver 16 may convert inputted video data into analog video signals using gamma voltages supplied from a gamma voltage generator (not shown).

[0047] In one aspect of the present invention, the data driver 16 may supply video signals to data lines DL1 to DLm+1 using a column inversion driving method. For example, the data driver 16 may supply video signals having a first polarity to the odd numbered data lines DL1, DL3, etc., and supply video signals having a second polarity, opposite the first polarity, to the even numbered data lines DL2, DL4, etc. In one aspect of the present invention, the data driver 16 may supply video signals to the liquid crystal cells in the liquid crystal display illustrated in FIG. 5 via data lines DL1 to DLm+1 in every horizontal period. Alternatively, the data driver 16 may supply the video signals by shifting them to the right by one channel. Accordingly, the

data driver 16 may be driven by a column inversion method and the video signals may be applied directly to the data lines or they may be shifted to the right by one channel before being applied to the data lines, thereby driving the liquid crystal cells of the liquid crystal display by a dot inversion method.

[0048] In one aspect of the present invention, the data driver 16 may apply video signals to odd numbered horizontal lines via the first to mth data lines DL1 to DLm. Subsequently, the data driver 16 may apply video signals to even numbered horizontal lines via the second to (m+1)th data lines DL2 to DLm+1 by shifting the previously applied video signals to the right by one channel to each of the data lines.

[0049] For example, in a first horizontal period when the first gate line GL1 is driven, video signals having a positive polarity applied from the data driver 16 may be supplied to the odd numbered liquid crystal cells connected to odd numbered data lines DL1, DL3, etc., while video signals having a negative polarity applied from the data driver 16 may be supplied to the even numbered liquid crystal cells connected to the even numbered data lines DL2, DL4, etc. Subsequently, in a second horizontal period when, for example, the second gate line GL2 is driven, the data driver 16 shifts the video signals applied in the first horizontal period to the right by one channel such that video signals having a negative polarity are applied to the odd numbered liquid crystal cells connected to the even numbered data lines DL2, DL4, etc., video signals having a positive polarity may be applied to the even numbered liquid crystal cells connected to the odd numbered data lines DL3, DL5, etc. Accordingly, the data driver 16 may be driven by a column inversion method while liquid crystal cells of the liquid crystal display panel 12 may be driven by a dot inversion method.

[0050] As shown in FIG. 5, consecutive liquid crystal cells arranged within a column may be alternately connected to left and right adjacent data lines may be driven using a dot inversion method while the data driver is driven by a column inversion method. Accordingly, the liquid crystal display shown in FIG. 5 may consume a relatively small amount of power during its operation compared to liquid crystal displays using data drivers driven according to dot inversion methods such as those illustrated in FIG. 1.

[0051] Referring now to FIG. 6, according one aspect of the present invention, the data driver 16 may include a plurality of driver integrated circuits (D-ICs) 34 mounted onto respective ones of tape carrier packages (TCPs) 38. The D-ICs 34 may be electrically connected to the data lines DL1 to DLm+1 via TCP pads 39, data pads 36, and links 30 and 32. Accordingly, the D-ICs 34 may apply predetermined video signals to the data lines DL1 to DLm+1 in response to externally supplied driving signals.

[0052] According to the principles of the present invention, the number of TCP pads 39 connected to each of the D-ICs 34 may correspond to a resolution of the liquid crystal display panel. For example, eight D-ICs 34 may be arranged within an XGA liquid crystal display panel to supply video signals to sets of 384 (128x3) data lines DL for driving the 3072 (1024x3) data lines DL. Further, ten D-ICs 34 may be arranged within an SXGA liquid crystal display panel to supply video signals to sets of 420 (140x3) data lines DL for

driving the 4200 (1400×3) data lines DL. Still further, ten D-ICs **34** may be arranged within a UXGA liquid crystal display panel to supply video signals to sets of 480 (160×3) data lines DL for driving the 4800 (1600×3) data lines DL.

[0053] The liquid crystal display panel **12** may, for example, include one more data line (DL_{m+1}) than liquid crystal display panels such as those illustrated in **FIG. 1** having only DL_m data lines. Accordingly, each of the D-IC **34** may, for example, include one extra output line compared to D-ICs within data drivers such as those illustrated in **FIG. 1**. For example, each of the D-ICs **34** may include 385 output lines connected to respective ones of data lines DL within the XGA liquid crystal display panel. Further, each of the D-ICs **34** may include 421 output lines connected to respective ones of data lines DL within the SXGA liquid crystal display panel. Still further, each of the D-ICs **34** may include 481 output lines connected to respective ones of data lines DL within the UXGA liquid crystal display panel.

[0054] Since each of the additional output lines arranged within the D-ICs **34** are connected to data lines DL within the liquid crystal display panel, a dummy output line **37** included within the D-IC **34** connected to the last data line DL_{m+1} is not used. Because each of the D-ICs **34** include an additional output line, one dummy output pin (not shown) is formed in each of the D-ICs **34**. Accordingly, seven additional (dummy) output lines **37** are provided in one D-IC **34** because consecutive ones of the additional output lines in preceding D-ICs **34** are connected to data lines DL. Therefore, a length of the last link **30** connected to the last data line DL_{m+1} has a length greater than lengths of other links **32** connected to other data lines DL₁ to DL_m.

[0055] As the length of the last link **30** increases, a timing with which video signals may be applied to the data lines DL to DL_{m+1} becomes non-uniform and accurate video data cannot be uniformly supplied to the data lines DL within the liquid crystal display panel. Additionally, a spacing between last link **30** and a link adjacent the last link is smaller than a spacing between other adjacent links **32**. Accordingly, a short circuit in the last link **30** may occur as a result of the reduced spacing.

[0056] **FIG. 7** illustrates a schematic view of driver integrated circuits arranged within a data driver according to a second aspect of the present invention

[0057] Referring to **FIG. 7**, the configuration liquid crystal display of the second aspect of the present invention is essentially the same as that shown in **FIG. 5**, with the exception of the data driver **40**. Accordingly, the liquid crystal display according to the second aspect of the present invention may, for example, include a liquid crystal display panel **12** having a plurality of liquid crystal cells arranged in a matrix pattern, a gate driver **14** for driving gate lines GL₁ to GL_n arranged in the liquid crystal display panel **12**, and a data driver **40** for driving data lines DL₁ to DL_{m+1} also arranged in the liquid crystal display panel **12**.

[0058] In one aspect of the present invention, a plurality of gate lines GL₁ to GL_n and a plurality of data lines DL₁ to DL_{m+1} may be insulated from each other where they cross in the liquid crystal display panel **12**. The liquid crystal cells, arranged in a matrix pattern, are provided at every crossing of the gate lines GL₁ to GL_n and the data lines DL₁ to DL_{m+1}. Each liquid crystal cell may include a thin film

transistor (TFT) connected to one of gate lines GL₁ to GL_n and a corresponding one of data lines DL₁ to DL_{m+1}

[0059] Although not shown, liquid crystal cells consecutively arranged within a column may include TFTs that are alternately connected left and right adjacent data lines DL. For example, liquid crystal cells arranged in odd numbered horizontal lines (e.g., liquid crystal cells including TFTs connected to odd numbered gate lines GL₁, GL₃, GL₅, etc.) may be connected to the first to mth data lines DL₁ to DL_m arranged to the left of a terminal connecting the TFT to the gate line GL. Liquid crystal cells of even numbered horizontal lines (e.g., liquid crystal cells including TFTs connected to even numbered gate lines GL₂, GL₄, GL₆, etc.) may be connected to the second to (m+1)th data lines DL₂ to DL_{m+1} arranged to the right of a terminal connecting the TFT to the gate line GL.

[0060] The gate driver **14** scans and sequentially applies gate signals to the gate lines GL₁ to GL_n to drive the corresponding TFTs. The data driver **40** converts inputted video data into analog video signals and supplies analog video signals, specific to the scanned gate line, to the data lines DL₁ to DL_{m+1} during the period when the gate signal is supplied to the scanned gate line. Additionally, the data driver **40** may convert inputted video data into analog video signals using gamma voltages supplied from a gamma voltage generator (not shown).

[0061] In one aspect of the present invention, the data driver **40** may supply video signals to the data lines DL₁ to DL_{m+1} using a column inversion driving method. For example, the data driver **40** may supply video signals having a first polarity to the odd numbered data lines DL₁, DL₃, etc., and supply video signals having a second polarity, opposite the first polarity, to the even numbered data lines DL₂, DL₄, etc. In one aspect of the present invention, the data driver **40** may supply video signals to the liquid crystal display illustrated in **FIG. 7** via data lines DL₁ to DL_{1+m} in every horizontal period. Alternatively, the data driver **40** may supply the video signals by shifting them to the right by one channel. Accordingly, the data driver **40** may be driven by a column inversion method and the video signals may be applied directly to the data lines or they may be shifted to the right by one channel before being applied to the data lines, thereby driving the liquid crystal cells of the liquid crystal display by a dot inversion method.

[0062] According to the principles of the present invention, the data driver **40** may include a plurality of driver integrated circuits (D-ICs) **50**. The D-ICs **50** may be mounted onto respective ones of tape carrier packages (TCPs) **51**. The D-ICs **50** may be electrically connected to the data lines DL₁ to DL_{m+1} via TCP pads **46**, data pads **44**, and links **42**. The D-ICs **50** may apply predetermined video signals to the data lines DL₁ to DL_{m+1} in response to externally supplied driving signals.

[0063] According to the principles of the present invention, the D-ICs **50** may include one dummy output pin (not shown) connected between a dummy TCP pad **48** and a corresponding dummy data pad **49**. For example, eight D-ICs **50** may be arranged within an XGA liquid crystal display panel. Accordingly, each of the eight D-ICs **50** may include a dummy TCP pad **48** connected to a respective ones of the dummy data pads **49** via a dummy output pin (not shown) provided in each of the D-ICs **50**. Video signals may

be applied only to the dummy TCP pad **48** and the dummy data pad **49** of the D-IC **50** connected to the last data line DL_{m+1} . Accordingly, video signals may not be applied to dummy TCP pads **48** and dummy data pads **49** of any of the other seven D-ICs **50**.

[**0064**] According to another aspect of the present invention, each of the D-ICs **50** may further include a switching pin. Generally, the switching pin determines whether or not the video signals are applied to the dummy output pin. For example, when the switching pin is in an OFF state, video signals are not applied to the dummy output pin. When the switching pin is in an ON state, video signals are applied to the dummy output pin. In one aspect of the present invention, each of the D-ICs **50** includes only one switching pin that is in an ON state while the rest of the switching pins within that D-IC **50** are in an OFF state.

[**0065**] For example, only the switching pin of the D-IC **50** connected to the last data line DL_{m+1} or the first data line DL_1 is in an ON state. Accordingly, a predetermined video signal may be selectively applied to the last data line DL_{m+1} . In one aspect of the present invention, dummy output lines included in the D-IC **50** may be connected to the last data line DL_{m+1} . In another aspect of the present invention, the length of all the link **42** is substantially uniform.

[**0066**] For example, compared to the data driver **16** shown in **FIG. 6** where a plurality of dummy output lines **37** exist in the D-IC **34** connected to the last data line DL_{m+1} , no dummy output line exists in the D-IC **50** connected to the last data line DL_{m+1} within the liquid crystal display panel **12** shown in **FIG. 7**. Accordingly, both the lengths of and the gaps between the adjacent links **42** may be substantially uniform.

[**0067**] According to the principles of the present invention, TFTs of liquid crystal cells within a column may be alternately connected to adjacent data lines on the left and right, thereby enabling the liquid crystal display panel to be driven by a dot inversion method while the data driver is driven by a column inversion method. The liquid crystal display panel is capable of operating under a reduced power consumption compared to liquid crystal display panels driven using dot inversion systems such as those illustrated in **FIG. 1**.

[**0068**] Additionally, one dummy output pin may be formed in each of D-ICs included within the data driver such that only one of the dummy output pins within each of the D-ICs applies video signals. Further, lengths of and gaps between adjacent links are substantially uniform.

[**0069**] It will be apparent to those skilled in the art that various modifications and variation can be made in the present invention without departing from the spirit or scope of the invention. Thus, it is intended that the present invention cover the modifications and variations of this invention provided they come within the scope of the appended claims and their equivalents.

1-12. (canceled)

13. The liquid crystal display according to claim **10**, wherein only the dummy output pin arranged within the driver integrated circuit connected to the first one of the plurality of successively arranged data lines transmits the video signal.

14. The liquid crystal display according to claim **10**, wherein only the dummy output pin arranged within the driver integrated circuit connected to the last one of the plurality of successively arranged data lines transmits the video signal.

15. The liquid crystal display according to claim **10**, wherein the video signal is applied to the first one of the plurality of successively arranged data lines via the dummy output pin.

16. The liquid crystal display according to claim **10**, wherein the video signal is applied to the last one of the plurality of successively arranged data lines via the dummy output pin.

17. The liquid crystal display according to claim **10**, wherein one data pad is connected to a single link.

18. A data driver for a display device, comprising:

at least one driver integrated circuit for applying a signal to a plurality of successively arranged conductive structures in a column inversion method;

a plurality of output pins arranged within the at least one driver integrated circuit; and a switching pin arranged within the at least one driver integrated circuit for controlling whether the signal is applied to a predetermined one of the plurality of output pins.

19. The data driver according to claim **18**, wherein the predetermined one of the plurality of output pins corresponds to a location of one of the plurality of successively arranged conductive structures.

20. The data driver according to claim **18**, wherein only one of the predetermined one of the plurality of output pins within the at least one driver circuit transmits the signal.

* * * * *

专利名称(译)	液晶显示器		
公开(公告)号	US20060012743A1	公开(公告)日	2006-01-19
申请号	US11/229619	申请日	2005-09-20
[标]申请(专利权)人(译)	YUN SAI常 宋泓SUNG		
申请(专利权)人(译)	YUN SAI常 宋泓SUNG		
当前申请(专利权)人(译)	LG DISPLAY CO. , LTD.		
[标]发明人	YUN SAI CHANG SONG HONG SUNG		
发明人	YUN, SAI CHANG SONG, HONG SUNG		
IPC分类号	G02F1/1345 G02F1/133 G02F1/13 G09G3/36		
CPC分类号	G02F1/13452 G09G3/3648 G09G3/3614		
优先权	1020020021794 2002-04-20 KR		
其他公开文献	US7379147		
外部链接	Espacenet USPTO		

摘要(译)

液晶显示器包括用于将视频信号施加到数据线的驱动器集成电路，输出引脚和至少一个虚拟输出引脚布置在每个数据驱动器集成电路内，并且开关引脚布置在每个数据驱动器集成电路内用于控制是否或者不是虚拟输出引脚输出信号。

