

FIG. 1 (PRIOR ART)

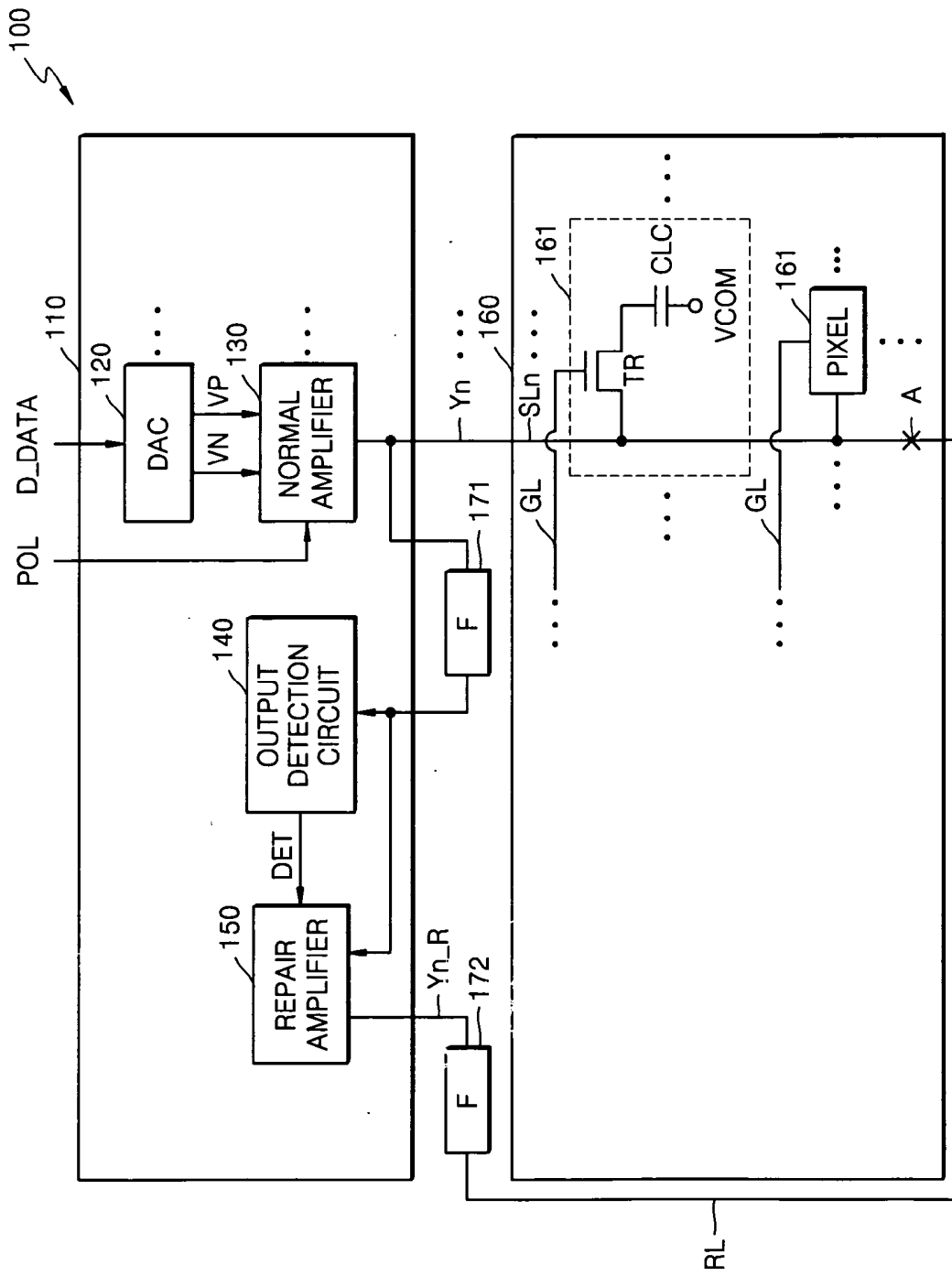

FIG. 2 (PRIOR ART)

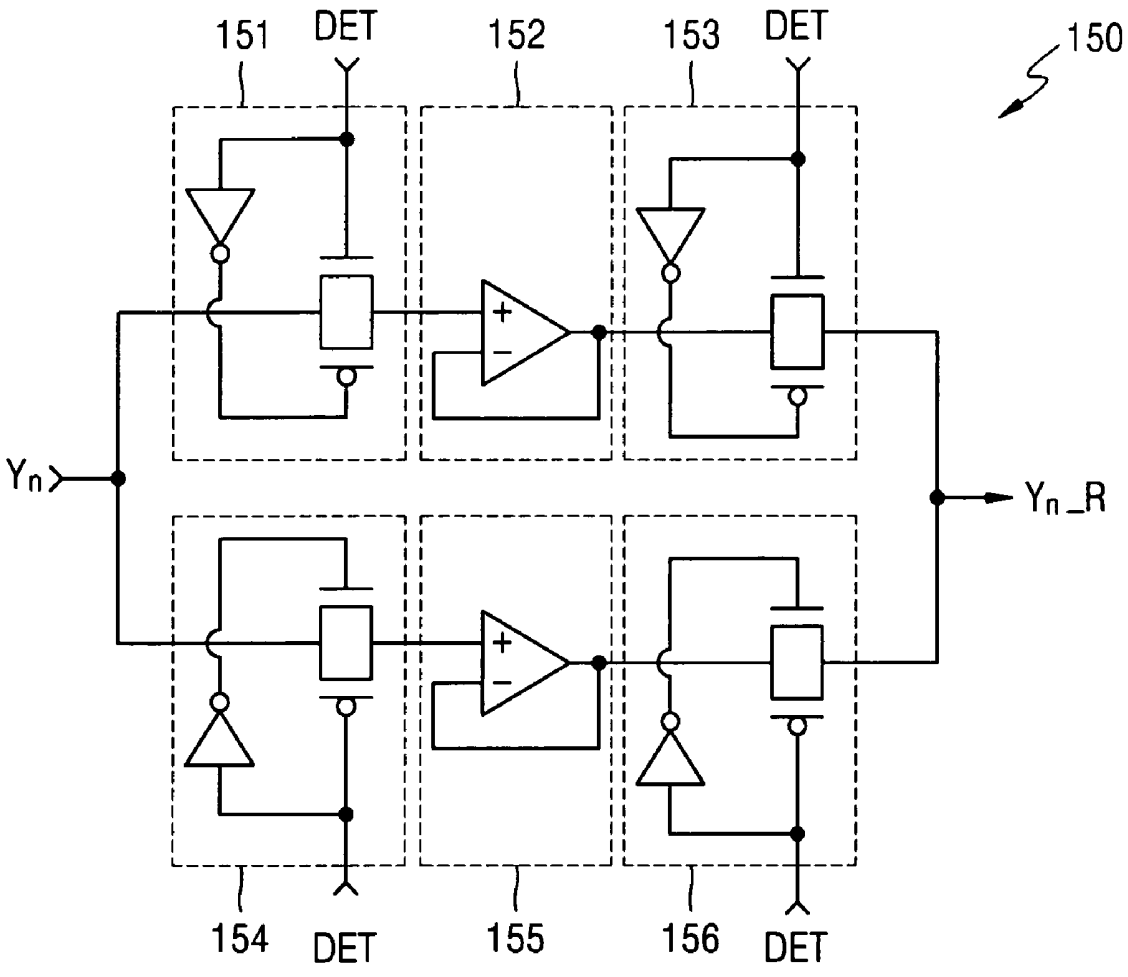

FIG. 3

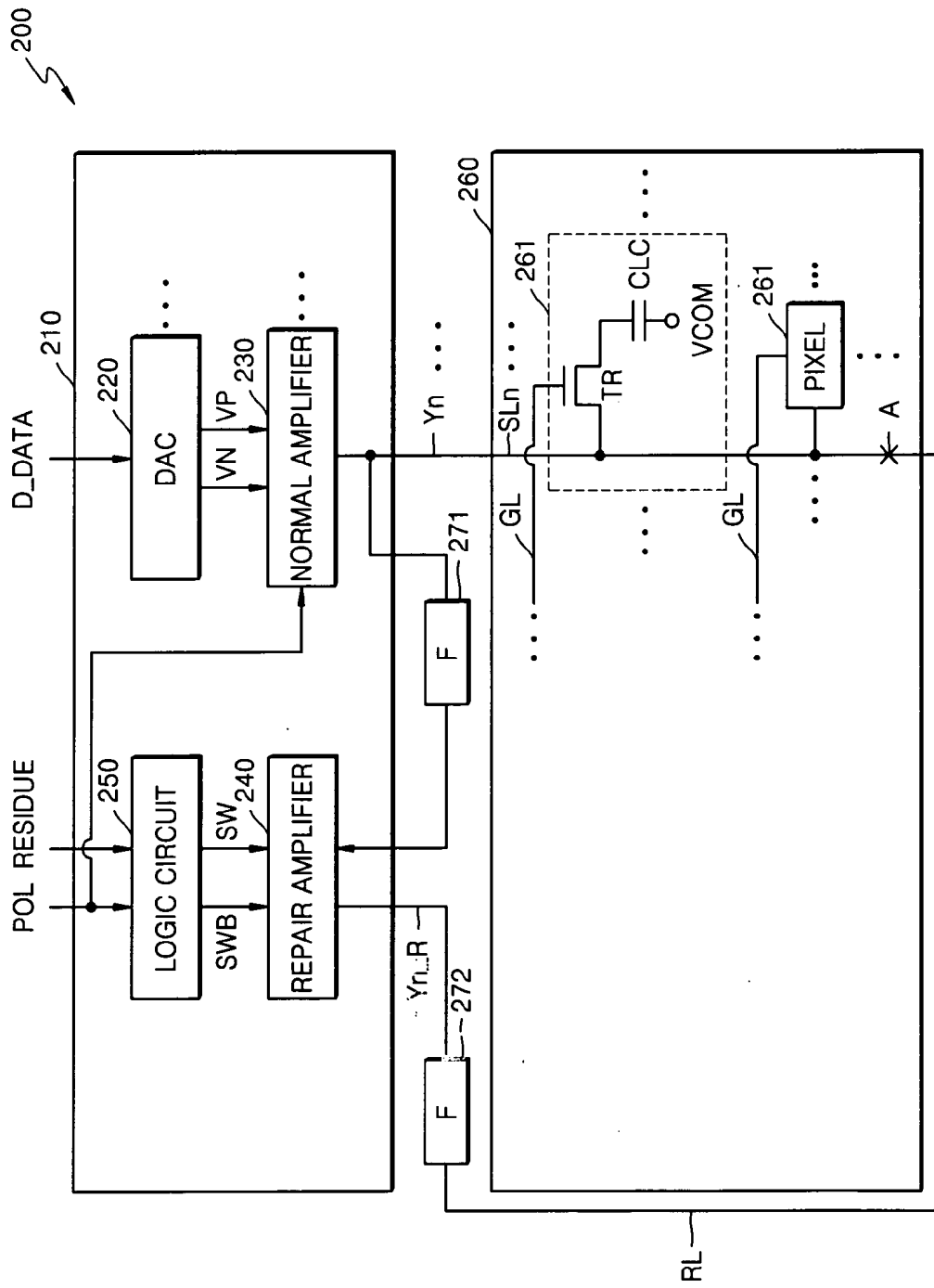

FIG. 6

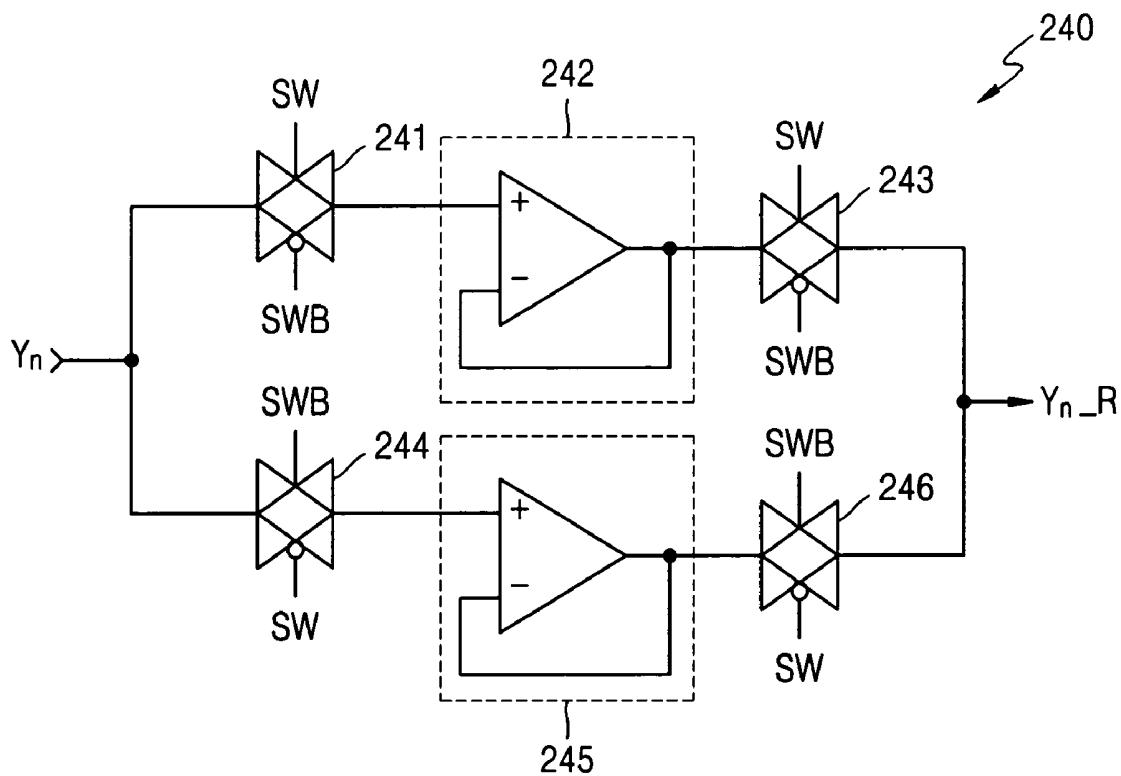
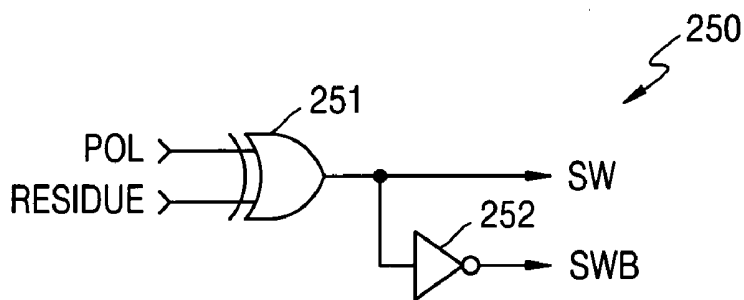

FIG. 7



LIQUID CRYSTAL DISPLAY DEVICE HAVING A SOURCE DRIVER AND A REPAIR AMPLIFIER

CROSS-REFERENCE TO RELATED APPLICATION

[0001] This application claims the priority of Korean Patent Application No. 10-2004-0008253, filed on Feb. 9, 2004, in the Korean Intellectual Property Office, the disclosure of which is incorporated herein in its entirety by reference.

BACKGROUND OF THE INVENTION

[0002] 1. Technical Field

[0003] The present invention relates to a liquid crystal display device, and more specifically, to a source driver having a repair amplifier and a liquid crystal display device comprising the source driver.

[0004] 2. Discussion of the Related Art

[0005] Liquid crystal display devices have merits such as decreased size, decreased thickness and lower power consumption over other types of display devices. They have been used for various types of electronic equipment such as notebook computers, office automation equipment and audio/video equipment. Specifically, active matrix type liquid crystal display devices, employing thin film transistors as switch elements, are suitable for displaying moving images.

[0006] FIG. 1 is a block diagram schematically illustrating a conventional liquid crystal display device. The conventional liquid crystal display device 100 comprises a source driver 110, a liquid crystal panel 160, a first fuse (F) 171 and a second fuse (F) 172.

[0007] The source driver 110 comprises digital-to-analog converters (DAC) 120, normal amplifiers 130, an output detection circuit 140 and a repair amplifier 150.

[0008] A plurality of digital-to-analog converters 120 and a plurality of normal amplifiers 130 are provided in the source driver 110. Source line driving signals, which are outputs of the normal amplifiers 130, are also output from the source driver 110. Each source line driving signal is represented by the reference numeral Y_n . The source line driving signals Y_n are generated by an inverted signal of a polarity control signal POL, and are inverted signals of an n-th source line driving signal Y_n .

[0009] Each DAC 120 converts a digital image signal D_DAT into analog image signals, VP and VN, and outputs the converted signal. The analog image signals VP and VN indicate a gray level voltage.

[0010] Each normal amplifier 130 amplifies the analog image signals VP and VN in response to the polarity control signal POL and generates the source line driving signal Y_n , which drives source line SL_n of the liquid crystal panel 160. The polarity control signal POL is a signal controlling the polarity of liquid crystal and is to be inverted every frame so as to prevent deterioration of the liquid crystal panel 160. Each normal amplifier 130 can be implemented as a single amplifier or a rail-to-rail amplifier.

[0011] When an open circuit defect (indicated by the letter A in the figure) is generated in one of the source lines SL_n ,

which can be due to errors made during the manufacture of the liquid crystal panel 160, the first and second fuses 171 and 172 can be melted with a laser to connect the metal lines arranged at both ends of the first and second fuses 171 and 172.

[0012] The output detection circuit 140 generates a detection signal DET, in response to the source line driving signal Y_n , that is applied when the metal lines at both ends of the first fuse 171 are connected by a laser. For example, when the voltage level of the source line driving signal Y_n ranges between VDD/2 and VDD, which is hereinafter referred to as a positive voltage, the output detection circuit 140 generates the detection signal DET of a high level. Similarly, when the voltage level of the source line driving signal Y_n ranges between VSS and VDD/2, which is hereinafter referred to as a negative voltage, the output detection circuit 140 generates the detection signal DET of a low level. The output detection circuit 140 can be implemented as an operational amplifier, wherein a reference voltage applied to the inverting input terminal of the operational amplifier may be VDD/2.

[0013] The repair amplifier 150 amplifies the source line driving signal Y_n transmitted through the first melted fuse 171, in response to the detection signal DET and generates a repair source line driving signal $Y_{n,R}$. The repair source line driving signal $Y_{n,R}$ drives, through a repair line RL, a part of the source line SL_n that is not driven due to an open-circuit defect A.

[0014] The liquid crystal panel 160 comprises a plurality of pixels 161. Each pixel 161 has a switch transistor TR and a liquid crystal capacitor CLC. The switch transistor TR is turned on or turned off in response to a signal driving a gate line GL. One end of the switch transistor TR is connected to source lines SL_n . The liquid crystal capacitor CLC is connected between the other end of the switch transistor TR and a common voltage VCOM. The common voltage VCOM can be VDD/2.

[0015] FIG. 2 is a circuit diagram illustrating an example of the repair amplifier shown in FIG. 1. Referring to FIG. 2, the repair amplifier 150 has switch circuits (151, 153, 154 and 156) and amplifiers (152 and 155). The two amplifiers 152 and 155 constitute a single amplifier.

[0016] Each switch circuit 151, 153, 154 and 156 includes an inverter and a transmission gate. Each switch circuit 151, 153, 154 and 156 is turned on or turned off in response to the detection signal DET.

[0017] Each amplifier 152 and 155 can be implemented with an operational amplifier configured as a voltage follower. The first amplifier 152 amplifies a positive voltage of the source line driving signal Y_n , transmitted when the detection signal DET has a high level, and supplies the amplified positive voltage to the repair source line driving signal $Y_{n,R}$. The second amplifier 155 amplifies a negative voltage of the source line driving signal Y_n , transmitted when the detection signal DET has a low level, and supplies the amplified negative voltage to the repair source line driving signal $Y_{n,R}$.

[0018] Since the conventional source driver 110 of a liquid crystal display device comprises the output detection circuit 140 implemented with an operational amplifier, which is an analog circuit, power consumption can be high due to

consumption of standby current, etc. In addition, generation of the repair source line driving signal Y_{n_R} can be delayed due to resistor-capacitor (RC) delay of the output detection circuit 140.

SUMMARY OF THE INVENTION

[0019] According to an exemplary embodiment of the present invention, there is provided a source driver of a liquid crystal display device that drives adjacent source lines with source line driving signals having a mutually inverted phase relationship. The source driver has a normal amplifier that amplifies an analog image signal, and generates the source line driving signal driving one of the source lines in response to a polarity control signal. There is also a repair amplifier that, when connected to the source line driving signal, amplifies the source line driving signal in response to the polarity control signal. It is then used to generate a repair source line driving signal that drives a repair line. The repair line can be connected to a part of the source line that is not driven by the source line driving signal due to a of the source line.

[0020] In another exemplary embodiment of the present invention the source driver may further comprise a logic circuit that generates a switch signal and an inverted signal of the switch signal allowing a repair source line driving signal to be generated as an output of the repair amplifier in response to the polarity control signal and an external control signal. The phase of the switch signal may be equal or opposite to the phase of the polarity control signal in response to a logic state of the external control signal.

[0021] In another exemplary embodiment of the present invention the phase of the switch signal may be equal to the phase of the polarity control signal when the external control signal has a logic low level. The phase of the switch signal may be opposite to the phase of the polarity control signal when the external control signal has a logic high level. The repair source line driving signals can be generated to have a phase opposite to that of the switch signal.

[0022] In another exemplary embodiment of the present invention the repair-amplifier may comprise a charging amplifier that amplifies a positive voltage of the source line driving signal and supplies the amplified positive voltage to the repair source line driving signal; and a discharging amplifier that amplifies a negative voltage of the source line driving signal and supplies the amplified negative voltage to the repair source line driving signal.

[0023] In another exemplary embodiment of the present invention the repair amplifier may further comprise. a first switch circuit that transmits the positive voltage of the source line driving signal to an input terminal of the charging amplifier in response to the switch signal. A second switch circuit that supplies the positive voltage amplified by the charging amplifier to the repair source line driving signal in response to the switch signal. A third switch circuit that transmits the negative voltage of the source line driving signal to an input terminal of the discharging amplifier in response to the inverted signal of the switch signal. A fourth switch circuit that supplies the negative voltage of the source line driving signal amplified by the discharging amplifier to the source line driving signal in response to the inverted signal of the switch signal.

[0024] In another exemplary embodiment of the present invention the logic circuit may comprise an exclusive OR gate that generates the switch signal in response to the polarity control signal and the external control signal, and an inverter that inverts the switch signal to generate the inverted signal of the switch signal.

[0025] In another exemplary embodiment of the present invention the normal amplifier may comprise a charging amplifier that amplifies a positive voltage of the analog image signal, and a discharging amplifier that amplifies a negative voltage of the analog image signal. A first switch circuit that supplies the amplified positive voltage to the source line driving signal in response to the polarity control signal, and a second switch circuit that supplies the amplified negative voltage to the source line driving signal in response to the polarity control signal.

[0026] In an exemplary embodiment of the present invention the repair amplifier comprises a single amplifier.

[0027] According to another exemplary embodiment of the present invention, there is provided a liquid crystal display device including a liquid crystal panel having a plurality of pixels connected to a plurality of source lines. There is also included a source driver that produces a plurality of source line driving signals to drive the plurality of source lines so that adjacent source lines are driven with the source line driving signals having a mutually inverted phase relationship. The source driver comprises a repair amplifier that, when connected to one of the plurality of source line driving signals that drives a defective one of the plurality of source lines and the defective source line, drives the pixels connected to a part of the defective source line that is not driven by the one of the source line driving signals. The repair amplifier is controlled by a polarity control signal controlling a polarity inversion of a liquid crystal corresponding to one of the pixels.

[0028] In another exemplary embodiment of the present invention there is provided a method of driving a liquid crystal panel using adjacent source lines and source line driving signals that have a mutually inverted phase relationship. The method steps comprising providing a source line driving signal that drives a source line. Processing the source line driving signal, in response to a polarity control signal, to generate a repair source line driving signal that is used to drive a part of the source line. This part of the source line is not being driven by the source line driving signal due to a defect of the source line.

[0029] In another exemplary embodiment of the present invention the processing of the source line driving signal comprises the method steps of receiving a switch signal and an inverted signal of the switch signal; the switch signal has been generated in response to the polarity control signal and an external control signal so the phase of the switch signal is equal or opposite to the phase of the polarity control signal in response to a logic state of the external control signal. Processing the source line driving signal, in response to the switch signal and the inverted signal of the switch signal, whereby the source line driving signal is processed in response to the polarity control signal.

[0030] In another exemplary embodiment of the present invention the switch signal is generated using explosive OR logic to process the polarity control signal and the external control signal.

[0031] In another exemplary embodiment of the present invention the step of processing the source line driving signal comprises amplifying a positive portion of the source line driving signal. Amplifying a negative portion of the source line driving signal. Combining the amplified positive and negative portions to generate the repair source line driving signal.

[0032] In another exemplary embodiment of the present invention the step of providing a source line driving signal comprises amplifying an analog image signal in response to a polarity control signal and outputting the source line driving signal.

[0033] In another exemplary embodiment of the present invention the step of amplifying an analog image signal comprises receiving a positive and a negative portion of the analog image signal. Amplifying the positive portion of the analog image signal. Amplifying the negative portion of the analog image signal. Combining, in response to the polarity control signal, the positive and negative portions of the analog image signal to form the source line driving signal.

[0034] In another exemplary embodiment of the present invention the positive and negative portions of the analog image signal are amplified relative to a common voltage.

[0035] According to an embodiment of the present invention, since the source driver described above comprises the logic circuit using the existing polarity control signal without detecting the output of the source line driving signal so as to control the repair amplifier, power consumption can be reduced and the repair source line driving signal can be more rapidly generated.

BRIEF DESCRIPTION OF THE DRAWINGS

[0036] The above and features of the present invention will become more apparent from the detailed description of exemplary embodiments thereof with reference to the attached drawings in which:

[0037] FIG. 1 is a block diagram schematically illustrating a conventional liquid crystal display device;

[0038] FIG. 2 is a circuit diagram illustrating an example of the repair amplifier shown in FIG. 1;

[0039] FIG. 3 is a block diagram schematically illustrating a liquid crystal display device according to an exemplary embodiment of the present invention;

[0040] FIG. 4 is a circuit diagram illustrating in more detail an exemplary embodiment of the normal amplifier shown in FIG. 3;

[0041] FIG. 5 is an exemplary timing diagram illustrating an operation of the normal amplifier shown in FIG. 4;

[0042] FIG. 6 is a circuit diagram illustrating in more detail an exemplary embodiment of the repair amplifier shown in FIG. 3;

[0043] FIG. 7 is a circuit diagram illustrating in more detail an exemplary embodiment of the logic circuit shown in FIG. 3.

DETAILED DESCRIPTION OF PREFERRED EMBODIMENTS

[0044] FIG. 3 is a block diagram schematically illustrating a liquid crystal display device in accordance with an

exemplary embodiment of the present invention. The liquid crystal display device 200 comprises a source driver 210, a liquid crystal panel 260, a first fuse (F) 271 and a second fuse (F) 272.

[0045] The exemplary source driver 210 comprises digital-to-analog converters (DAC) 220, normal amplifiers 230, a repair amplifier 240 and a logic circuit 250.

[0046] A plurality of digital-to-analog converters 220 and a plurality of normal amplifiers 230 are arranged in the source driver 210, and source line driving signals which are outputs of the normal amplifiers 230 may be, for example, Y_{n-1} or Y_{n+1} (not shown). The Y_{n-1} and Y_{n+1} are generated by an inverted signal of a polarity control signal POL and are inverted signals of an n-th source line driving signal Y_n .

[0047] Each DAC 220 converts digital image signal D_DATA into analog image signals (VP and VN) and outputs the converted signals. The analog image signals VP and VN indicate a gray level voltage.

[0048] Each normal amplifier 230 amplifies the analog image signals (VP and VN) in response to the polarity control signal POL and generates the source line driving signal Y_n that drives source line SL_n of the liquid crystal panel 260. The polarity control signal POL is a signal controlling the polarity of liquid crystal. It can be inverted every frame to prevent deterioration of the liquid crystal panel 260. An exemplary source line driving method using the normal amplifiers 230 is a column inversion method in which adjacent source lines are driven with the source line driving signals having a mutually inverted phase. Each normal amplifier 230 can be implemented as a single amplifier or a rail-to-rail amplifier.

[0049] Referring still to FIG. 3, when an open-circuit defect A is generated in the source line SL_n because of errors in the manufacturing of the liquid crystal panel 260, the first and second fuses 271 and 272 are melted by a laser to connect metal lines arranged at both ends of the first and second fuses 271 and 272.

[0050] In another exemplary embodiment of the present invention open-circuits may be generated in four source lines of a total eight source lines. In this case, four repair amplifiers 240, four logic circuits 250, four first fuses 271, four second fuses 272 and four repair lines RL may be required.

[0051] Referring to the exemplary embodiment of FIG. 3 repair amplifier 240 amplifies the source line driving signal Y_n , transmitted through the first melted fuse 271, in response to a switch signal SW and an inverted signal SWB of the switch signal SW. The repair amplifier 240 also generates a repair source line driving signal $Y_{n,R}$. The repair source line driving signal $Y_{n,R}$ drives, through the repair line RL, the part of a source line SL_n that is not driven due to the open-circuit defect A; the phase of $Y_{n,R}$ is equal to the phase of the polarity control signal POL. The adjacent (n-1)-th or (n+1)-th repair source line driving signal $Y_{n-1,R}$ or $Y_{n+1,R}$, not shown in FIG. 3, is an inverted signal of the n-th repair source line driving signal $Y_{n,R}$, and the phase thereof is opposite to the phase of the polarity control signal POL. That is, the phase difference between $Y_{n-1,R}$ (or $Y_{n+1,R}$) and PLO is 180 degrees.

[0052] The logic circuit 250 generates the switch signal SW and the inverted signal SWB of the switch signal SW in

response to the polarity control signal POL and an external control signal RESIDUE. The external control signal RESIDUE is applied from outside the source driver **210**.

[0053] In the exemplary embodiment depicted in **FIG. 3** the phase of the switch signal SW may be equal or opposite to the phase of the polarity control signal POL in accordance with a logic state of the external control signal RESIDUE. That is, when the external control signal RESIDUE has a low level, the phase of the switch signal SW is equal to the phase of the polarity control signal POL. The n-th repair source line driving signal Y_{n_R} is generated from the switch signal SW. The adjacent (n-1)-th or (n+1)-th repair source line driving signal Y_{n-1_R} or Y_{n+1_R} is an inverted signal of the n-th repair source line driving signal Y_{n_R} , and is generated from the switch signal SW based on the external control signal RESIDUE of a high level. That is, when the external control signal RESIDUE has a high level, the phase of the switch signal SW is opposite to the phase of the polarity control signal POL.

[0054] Therefore, since the source driver **210** according to an exemplary embodiment of the present invention comprises the logic circuit **250** using the existing polarity control signal POL without detecting outputs of the source line driving signals Y_{n-1} , Y_n and Y_{n+1} the power consumption can be further reduced and repair source line driving signals Y_{n-1_R} , Y_{n_R} and Y_{n+1_R} can be generated more rapidly as compared with the conventional source driver. In addition, since a liquid crystal display device **200** according to the present invention comprises the above source driver, power consumption can be reduced and stable images can be displayed.

[0055] An exemplary liquid crystal panel **260** comprises a plurality of pixels **261**. Each pixel **261** has a switch transistor TR and a liquid crystal capacitor CLC. The switch transistor TR is turned on or turned off in response to a signal driving a gate line GL, and one end of the switch transistor TR is connected to source lines SL_n . The liquid crystal capacitor CLC is connected between the other end of the switch transistor TR and a common voltage VCOM. For example, the common voltage VCOM may be VDD/2.

[0056] **FIG. 4** is a circuit diagram illustrating in more detail an exemplary embodiment of the normal amplifier shown in **FIG. 3**, in accordance with the present invention. Referring to **FIG. 4**, the normal amplifier **230** comprises a charging amplifier **231**, a discharging amplifier **233** and switch circuits **232** and **234**. The charging amplifier **231** and the discharging amplifier **233** constitute a single amplifier.

[0057] The charging amplifier **231** can be implemented with an operational amplifier configured as a voltage follower. The charging amplifier **231** amplifies a positive voltage VP of an analog image signal and transmits the amplified positive voltage to the first switch circuit **232**.

[0058] The discharging amplifier **233** can be implemented with an operational amplifier configured as a voltage follower. The discharging amplifier **233** amplifies a negative voltage VN of the analog image signal and transmits the amplified negative voltage to the second switch circuit **234**.

[0059] The first switch circuit **232** comprises an inverter INV1 and a transmission gate TG1. The first switch circuit **232** is turned on in response to the polarity control signal

POL of a high level and supplies the positive voltage VP amplified by the charging amplifier **231** to the source line driving signal Y_n .

[0060] The second switch circuit **234** comprises an inverter INV2 and a transmission gate TG2. The second switch circuit **234** is turned on in response to the polarity control signal POL of a low level and supplies the negative voltage VN amplified by the discharging amplifier **233** to the source line driving signal Y_n .

[0061] **FIG. 5** is an exemplary timing diagram illustrating an operation of the normal amplifier shown in **FIG. 4**.

[0062] The operation of the normal amplifier **230** will be described with reference to **FIGS. 4 and 5**. The charging amplifier **231** amplifies the periodic positive voltage VP, and the discharging amplifier **233** amplifies the periodic negative voltage VN. At that time, when the switch circuits **232** and **234** are turned on in accordance with a high level and a low level, respectively, of the polarity control signal POL. The source line driving signal Y_n is periodically generated from the amplified positive voltage VP and the amplified negative voltage VN. In the source line driving signal Y_n , a voltage larger than the common voltage VCOM (equal to VDD/2 in this case) indicates a positive voltage, and a voltage smaller than the common voltage VCOM indicates a negative voltage.

[0063] Another exemplary embodiment of a normal amplifier, in accordance with the present invention, can be implemented as follows. This normal amplifier can be used to generate the source line driving signals (Y_{n-1} and Y_{n+1}) driving the adjacent source lines of the source line SL_n (depicted in **FIG. 3**). It can be implemented by connecting the charging amplifier **231** to the second switch circuit **234** and connecting the discharging amplifier **233** to the first switch circuit **232**.

[0064] This exemplary embodiment of a normal amplifier can generate the inverted signal Y_{n-1} or Y_{n+1} of the source line driving signal Y_n . In this case, the phase of the inverted signal Y_{n-1} or Y_{n+1} of the source line driving signal Y_n is opposite to the phase of the polarity control signal POL.

[0065] **FIG. 6** is a circuit diagram illustrating in more detail an exemplary embodiment of the repair amplifier shown in **FIG. 3**, in accordance with the present invention. The repair amplifier **240** comprises switch circuits **241**, **243**, **244** and **246**. It also comprises a charging amplifier **242** and a discharging amplifier **245**. The charging amplifier **242** and the discharging amplifier **245** constitute a single amplifier. Each of the switch circuits **241**, **243**, **244** and **246** comprises a transmission gate.

[0066] The switch circuits **241** and **243**, connected to the input and output terminals of the charging amplifier **242**, are turned on in response to a switch signal SW of a high level and an inverted signal SWB, of the switch signal SW, where the inverted signal SWB has a low level.

[0067] The charging amplifier **242** can be implemented with an operational amplifier configured as a voltage follower. The charging amplifier **242** amplifies a positive voltage of the source line driving signal Y_n , transmitted from the first switch circuit **241**, and supplies the amplified positive voltage to the repair source line driving signal Y_{n_R} transmitted to the second switch circuit **243**.

[0068] The switch circuits 244 and 246 connected to the input and output terminals of the discharging amplifier 245 are turned on in response to the inverted signal SWB of the switch signal SW and the switch signal SW of a low level, where the inverted signal SWB has a high level.

[0069] The discharging amplifier 245 can be implemented with an operational amplifier configured as a voltage follower. The discharging amplifier 245 amplifies a negative voltage of the source line driving signal Y_n , transmitted from the third switch circuit 244, and supplies the amplified negative voltage to the repair source line driving signal Y_{n_R} transmitted to the fourth switch circuit 246.

[0070] The phase of the repair source line driving signal Y_{n_R} is equal to the phase of the polarity control signal POL. On the other hand, although not shown in FIG. 6, the phase of the repair source line driving signal Y_{n-1_R} or Y_{n+1_R} is opposite to the phase of the polarity control signal POL.

[0071] FIG. 7 is a circuit diagram illustrating in more detail an exemplary embodiment of the logic circuit shown in FIG. 3, in accordance with the present invention. The logic circuit 250 comprises an exclusive OR (XOR) gate 251 and an inverter 252.

[0072] The XOR gate 251 generates the switch signal SW in response to the polarity control signal POL and the external control signal RESIDUE. The inverter 252 generates the inverted signal SWB of the switch signal SW.

[0073] When the external control signal RESIDUE is at a low level, the switch signal SW that is generated has a phase equal to the phase of the polarity control signal POL. Thus, the n-th repair source line driving signal Y_{n_R} is generated from the switch signal SW. However, when the external control signal RESIDUE is at a high level, the switch signal SW that is generated has a phase opposite to the phase of the polarity control signal POL. Thus, the (n-1)-th repair source line driving signal Y_{n-1_R} or the (n+1)-th repair source line driving signal Y_{n+1_R} is generated from the switch signal SW. Therefore, the phases of the adjacent repair source line driving signals are opposite to each other.

[0074] While the present invention has been particularly shown and described with reference to exemplary embodiments thereof, it will be understood by those skilled in the art that various changes in form and details may be made therein without departing from the spirit and scope of the present invention as defined by the appended claims.

What is claimed is:

1. A source driver of a liquid crystal display device that drives adjacent source lines with source line driving signals having a mutually inverted phase relationship, the source driver comprising:

a normal amplifier that amplifies an analog image signal and generates a source line driving signal that drives one of the source lines in response to a polarity control signal; and

a repair amplifier that, when connected to the source line driving signal, amplifies the source line driving signal, in response to the polarity control signal, to generate a repair source line driving signal that drives a repair line, wherein the repair line is connected to a part of the source line that is not driven by the source line driving signal due to a defect of the source line.

2. A source driver of claim 1, further comprising a logic circuit that generates both a switch signal and an inverted signal of the switch signal that allows the repair source line driving signal to be generated as an output of the repair amplifier in response to the polarity control signal and an external control signal, wherein the phase of the switch signal is equal or opposite to the phase of the polarity control signal in response to a logic state of the external control signal.

3. A source driver of claim 2, wherein the phase of the switch signal is equal to the phase of the polarity control signal when the external control signal has a logic low level, and the phase of the switch signal is opposite to the phase of the polarity control signal when the external control signal has a logic high level, whereby the repair source line driving signal is generated to have the opposite phase of the switch signal.

4. A source driver of claim 3, wherein the repair amplifier comprises:

a charging amplifier that amplifies a positive voltage of the source line driving signal and supplies the amplified positive voltage to the repair source line driving signal; and

a discharging amplifier that amplifies a negative voltage of the source line driving signal and supplies the amplified negative voltage to the repair source line driving signal.

5. A source driver of claim 4, wherein the repair amplifier further comprises:

a first switch circuit that transmits the positive voltage of the source line driving signal to an input terminal of the charging amplifier in response to the switch signal;

a second switch circuit that supplies the amplified positive voltage to the repair source line driving signal in response to the switch signal;

a third switch circuit that transmits the negative voltage of the source line driving signal to an input terminal of the discharging amplifier in response to the inverted signal of the switch signal; and

a fourth switch circuit that supplies the amplified negative voltage to the source line driving signal in response to the inverted signal of the switch signal.

6. A source driver of claim 5, wherein each of the switch circuits includes a transmission gate.

7. A source driver of claim 6, wherein the logic circuit comprises:

an exclusive OR gate that generates the switch signal in response to the polarity control signal and the external control signal; and

an inverter that inverts the switch signal to generate the inverted signal of the switch signal.

8. A source driver of claim 7, wherein each of the charging amplifiers and the discharging amplifiers comprises an operational amplifier configured as a voltage follower.

9. A source driver of claim 3, wherein the normal amplifier comprises:

a charging amplifier that amplifies a positive voltage of the analog image signal;

a discharging amplifier that amplifies a negative voltage of the analog image signal;

a first switch circuit that supplies the amplified positive voltage to the source line driving signal in response to the polarity control signal; and

a second switch circuit that supplies the amplified negative voltage to the source line driving signal in response to the polarity control signal.

10. A source driver of claim 9, wherein each of the charging amplifiers and the discharging amplifiers comprises an operational amplifier configured as a voltage follower.

11. The source driver according to claim 10, wherein each of the first and second switch circuits comprises a transmission gate and an inverter.

12. A source driver of claim 1, wherein the repair amplifier comprises a single amplifier.

13. A liquid crystal display device, comprising:

a liquid crystal panel having a plurality of pixels connected to a plurality of source lines; and

a source driver that produces a plurality of source line driving signals to drive the plurality of source lines so that adjacent source lines are driven with the source line driving signals having a mutually inverted phase relationship,

wherein the source driver comprises a repair amplifier that, when connected to one of the plurality of source line driving signals that drives a defective one of the plurality of source lines and the defective source line, drives the pixels connected to a part of the defective source line that is not driven by the one of the source line driving signals,

wherein the repair amplifier is controlled by a polarity control signal that also controls a polarity inversion of a liquid crystal corresponding to one of the pixels.

14. A method of driving a liquid crystal panel using adjacent source lines and source line driving signals that have a mutually inverted phase relationship, comprising:

providing a source line driving signal that drives a source line;

processing the source line driving signal, in response to a polarity control signal, to generate a repair source line driving signal that is used to drive a part of the source line, wherein the part of the source line is not driven by the source line driving signal due to a defect of the source line.

15. A method of claim 14, wherein the processing of the source line driving signal comprises:

receiving a switch signal and an inverted signal of the switch signal, which is generated in response to the polarity control signal and an external control signal so the phase of the switch signal is equal or opposite to the phase of the polarity control signal in response to a logic state of the external control signal; and

processing the source line driving signal, in response to the switch signal and the inverted signal of the switch signal, whereby the source line driving signal is processed in response to the polarity control signal.

16. A method of claim 15, wherein the switch signal is generated using explosive OR logic to process the polarity control signal and the external control signal.

17. A method of claim 14, wherein the step of processing the source line driving signal comprises:

amplifying a positive portion of the source line driving signal;

amplifying a negative portion of the source line driving signal; and

combining the amplified positive and negative portions to generate the repair source line driving signal.

18. A method of claim 14, wherein the step of providing a source line driving signal comprises: amplifying an analog image signal in response to a polarity control signal; and

outputting the source line driving signal.

19. A method of claim 18, wherein the step of amplifying an analog image signal comprises:

receiving a positive and a negative portion of the analog image signal;

amplifying the positive portion of the analog image signal;

amplifying the negative portion of the analog image signal; and

combining, in response to the polarity control signal, the positive and negative portions of the analog image signal to form the source line driving signal.

20. A method of claim 19, wherein the positive and negative portions of the analog image signal are amplified relative to a common voltage.

* * * * *

专利名称(译)	液晶显示装置具有源极驱动器和修复放大器		
公开(公告)号	US20050174316A1	公开(公告)日	2005-08-11
申请号	US11/038358	申请日	2005-01-19
[标]申请(专利权)人(译)	三星电子株式会社		
申请(专利权)人(译)	SAMSUNG ELECTRONICS CO. , LTD.		
当前申请(专利权)人(译)	SAMSUNG ELECTRONICS CO. , LTD.		
[标]发明人	KANG CHANG SIG		
发明人	KANG, CHANG-SIG		
IPC分类号	G09G3/36		
CPC分类号	G09G2330/08 G09G3/3688		
优先权	1020040008253 2004-02-09 KR		
其他公开文献	US7432904		
外部链接	Espacenet USPTO		

摘要(译)

提供了一种具有修复放大器的源极驱动器和处理信号的方法。还提供了一种包含源极驱动器的液晶显示装置。源极驱动器利用源极线驱动信号驱动相邻的源极线。修复放大器放大源极线驱动信号以驱动源极线的一部分。

