



US008189135B2

(12) **United States Patent**
Bae et al.

(10) **Patent No.:** **US 8,189,135 B2**
(45) **Date of Patent:** **May 29, 2012**

(54) **LED BACK-LIGHT UNIT AND LIQUID CRYSTAL DISPLAY DEVICE USING THE SAME**

(75) Inventors: **Seung Choon Bae**, Suwon-si (KR); **Seung Se Kim**, Yongin-si (KR); **Hoon Hur**, Seoul (KR)

(73) Assignee: **LG Electronics Inc.**, Seoul (KR)

(*) Notice: Subject to any disclaimer, the term of this patent is extended or adjusted under 35 U.S.C. 154(b) by 231 days.

(21) Appl. No.: **12/453,885**

(22) Filed: **May 26, 2009**

(65) **Prior Publication Data**

US 2009/0296026 A1 Dec. 3, 2009

(30) **Foreign Application Priority Data**

| | | |
|---------------|------|-----------------|
| May 27, 2008 | (KR) | 10-2008-0049146 |
| Jun. 27, 2008 | (KR) | 10-2008-0061487 |
| Oct. 10, 2008 | (KR) | 10-2008-0099569 |
| Apr. 22, 2009 | (KR) | 10-2009-0035029 |

(51) **Int. Cl.**
G02F 1/1335 (2006.01)
G02F 1/1333 (2006.01)
F21V 7/04 (2006.01)

(52) **U.S. Cl.** **349/61**; 349/58; 349/65; 362/612; 362/616

(58) **Field of Classification Search** 349/61, 349/65, 67, 58; 362/612-613, 602, 623, 362/616

See application file for complete search history.

(56) **References Cited**

U.S. PATENT DOCUMENTS

| | | |
|-------------|--------|---------------|
| 5,704,703 A | 1/1998 | Yamada et al. |
| 5,717,422 A | 2/1998 | Ferguson |

(Continued)

FOREIGN PATENT DOCUMENTS

EP 0 987 490 5/2010

(Continued)

OTHER PUBLICATIONS

PCT International Search Report dated Oct. 27, 2010 issued in Application No. PCT/KR2010/001492.

(Continued)

Primary Examiner — Nathanael R Briggs

(74) *Attorney, Agent, or Firm* — KED & Associates, LLP

(57) **ABSTRACT**

An LED back-light unit and other devices using the LED back-light unit are discussed. According to one embodiment, an LED back-light unit includes a light guide portion that includes a light guide plate and a reflection plate coupled to the light guide plate, wherein the light guide plate has a light input part and a first connection part, and wherein the reflection plate has a second connection part connected to the first connection part, and a light source including at least one light emitting diode, the light source emitting light toward the light guide portion.

25 Claims, 25 Drawing Sheets

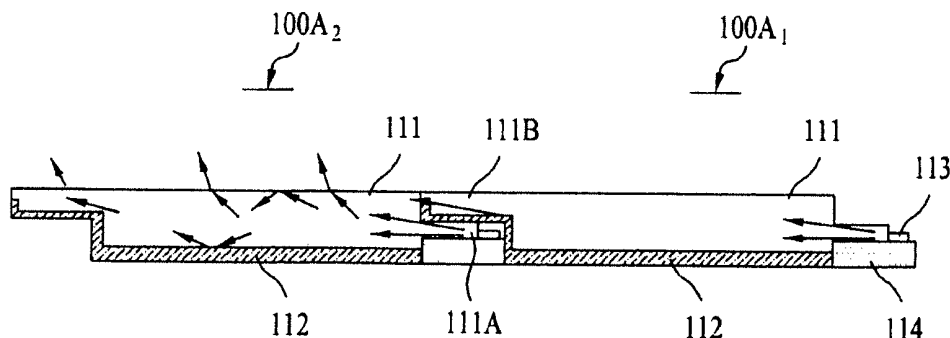

U.S. PATENT DOCUMENTS

| | | | | |
|--------------|-----|---------|----------------------|---------|
| 6,241,358 | B1 | 6/2001 | Higuchi et al. | |
| 6,456,343 | B2 | 9/2002 | Kim et al. | |
| 6,816,141 | B1 | 11/2004 | Ferguson | |
| 7,125,152 | B2 | 10/2006 | Lin et al. | |
| 7,311,431 | B2 | 12/2007 | Chew et al. | |
| 7,312,838 | B2 | 12/2007 | Hwang et al. | |
| 7,413,330 | B2 | 8/2008 | Furukawa | |
| 7,641,375 | B2* | 1/2010 | Fujita et al. | 362/617 |
| 8,113,704 | B2 | 2/2012 | Bae et al. | 362/613 |
| 2001/0017774 | A1 | 8/2001 | Ito | |
| 2003/0206253 | A1* | 11/2003 | Cho | 349/61 |
| 2005/0248939 | A1 | 11/2005 | Li et al. | |
| 2005/0276075 | A1 | 12/2005 | Chen et al. | |
| 2006/0044830 | A1 | 3/2006 | Inoue et al. | 362/614 |
| 2006/0114690 | A1 | 6/2006 | Iki et al. | 362/612 |
| 2006/0209564 | A1 | 9/2006 | Lin et al. | |
| 2006/0221638 | A1 | 10/2006 | Chew et al. | |
| 2006/0239033 | A1 | 10/2006 | Jung et al. | 362/612 |
| 2006/0245213 | A1 | 11/2006 | Beil et al. | 362/616 |
| 2007/0019419 | A1 | 1/2007 | Hafuka et al. | |
| 2007/0058390 | A1 | 3/2007 | Sugawara et al. | 356/560 |
| 2007/0076434 | A1 | 4/2007 | Uehara et al. | 362/616 |
| 2007/0247869 | A1 | 10/2007 | Lang et al. | |
| 2007/0247871 | A1* | 10/2007 | Yoo | 362/612 |
| 2008/0205080 | A1* | 8/2008 | Erchak et al. | 362/613 |
| 2011/0051045 | A1 | 3/2011 | Hur et al. | |

FOREIGN PATENT DOCUMENTS

| | | |
|----|---------------|---------|
| JP | 64029708 | 2/1989 |
| JP | 01-261692 | 10/1989 |
| JP | 08-160425 | 6/1996 |
| JP | 09-171111 A | 6/1997 |
| JP | 09-186825 | 7/1997 |
| JP | 09-292531 | 11/1997 |
| JP | 11-288611 | 10/1999 |
| JP | 2002-228844 A | 8/2002 |
| JP | 2004-206916 | 7/2004 |
| JP | 2005-259361 | 9/2005 |
| JP | 2005-259361 A | 9/2005 |
| JP | 2005-317480 | 11/2005 |
| JP | 2006-054410 A | 2/2006 |
| JP | 2006-108033 | 4/2006 |
| JP | 2006-0134748 | 5/2006 |
| JP | 2006-269364 A | 10/2006 |
| JP | 2006-286638 | 10/2006 |
| JP | 2007-250197 A | 9/2007 |
| JP | 2007-250979 A | 9/2007 |
| JP | 2007-265837 A | 10/2007 |
| JP | 2007-293339 | 11/2007 |
| JP | 2007-293339 A | 11/2007 |
| JP | 2008-108622 | 5/2008 |
| JP | 2008-108623 | 5/2008 |
| JP | 2008-108623 A | 5/2008 |

| | | |
|----|-------------------|---------|
| JP | 2008-192395 | 8/2008 |
| JP | 2008/192395 | 8/2008 |
| JP | 2009-054990 A | 3/2009 |
| KR | 2001-0012532 | 2/2001 |
| KR | 10-2001-0085460 A | 9/2001 |
| KR | 10-2003-016631 | 3/2003 |
| KR | 10-2005-0067858 | 7/2005 |
| KR | 10-2005-0067903 | 7/2005 |
| KR | 10-2006-0106774 | 10/2006 |
| KR | 10-2007-0001657 | 1/2007 |
| KR | 10-2007-0029365 A | 3/2007 |
| KR | 10-2007-0104149 A | 10/2007 |
| KR | 10-2009-0022350 A | 3/2009 |
| WO | WO 2009/017067 | 2/2009 |
| WO | WO 2010/038516 | 4/2010 |

OTHER PUBLICATIONS

PCT International Search Report dated Oct. 29, 2010 issued in Application No. PCT/KR2010/001485.
 Korean Office Action dated Dec. 21, 2010 issued in Application No. 10-2008-0049146.
 Korean Office Action dated Dec. 21, 2010 issued in Application No. 10-2008-0099569.
 PCT International Search Report dated Sep. 30, 2010 issued in Application No. PCT/KR2010/001067.
 PCT International Search Report dated Sep. 30, 2010 issued in Application No. PCT/KR2010/001420.
 Search Report dated Oct. 28, 2010 for Application No. PCT/KR2010/010422.
 Search Report dated Oct. 28, 2010 for Application No. PCT/KR2010/010423.
 Search Report dated Oct. 28, 2010 for Application No. PCT/KR2010/010424.
 Search Report dated Oct. 28, 2010 for Application No. PCT/KR2010/010425.
 Office Action dated Feb. 17, 2011 for U.S. Appl. No. 12/618,603.
 Office Action dated Sep. 7, 2010 from U.S. Appl. No. 12/618,603.
 European Search Report for Application 10015492.1 dated Apr. 26, 2011.
 Korean Notice of Allowance for Application No. 10-2008-0049146 dated Nov. 30, 2011 and English translation.
 Korean Notice of Allowance dated Aug. 30, 2011 for Application No. 10-2008-0049146 (English translation).
 European Search Report dated Aug. 30, 2011 for Application No. 09 75 5013.
 U.S. Office Action dated Oct. 25, 2011 for U.S. Appl. No. 12/727,966.
 Office Action dated Feb. 1, 2012 for U.S. Appl. No. 12/632,694.
 Notice of Allowance dated Apr. 4, 2012 for U.S. Appl. No. 12/768,982.

* cited by examiner

FIG. 1

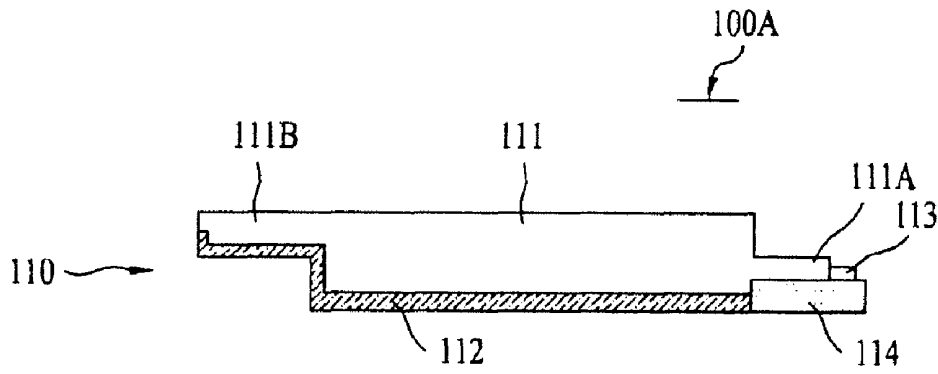

FIG. 2

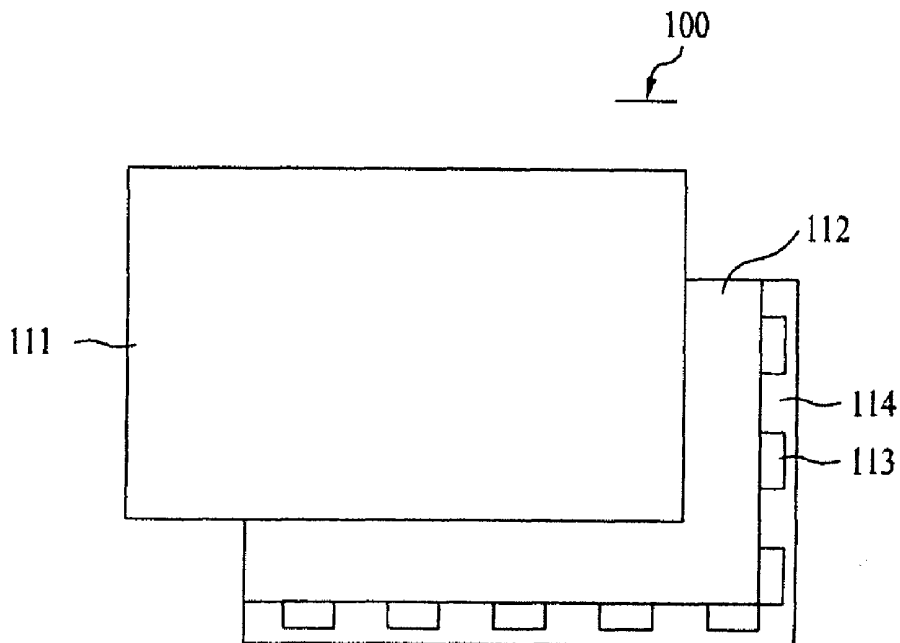

FIG. 3

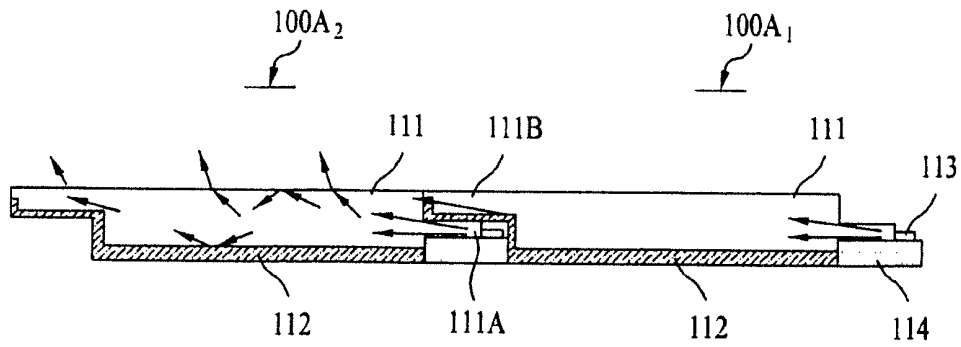

FIG. 4

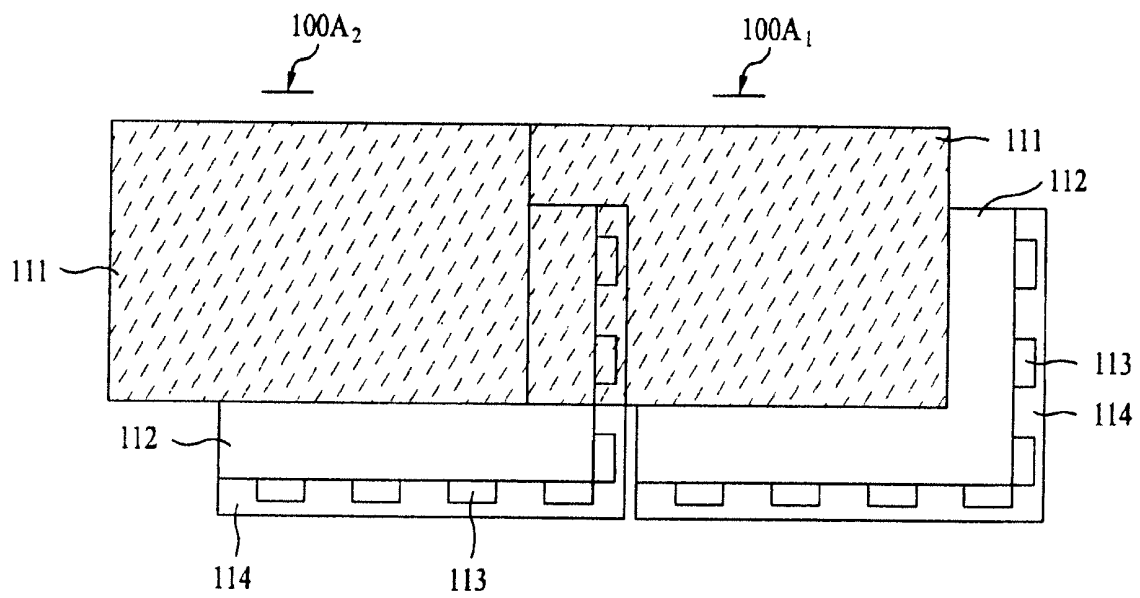

FIG. 5

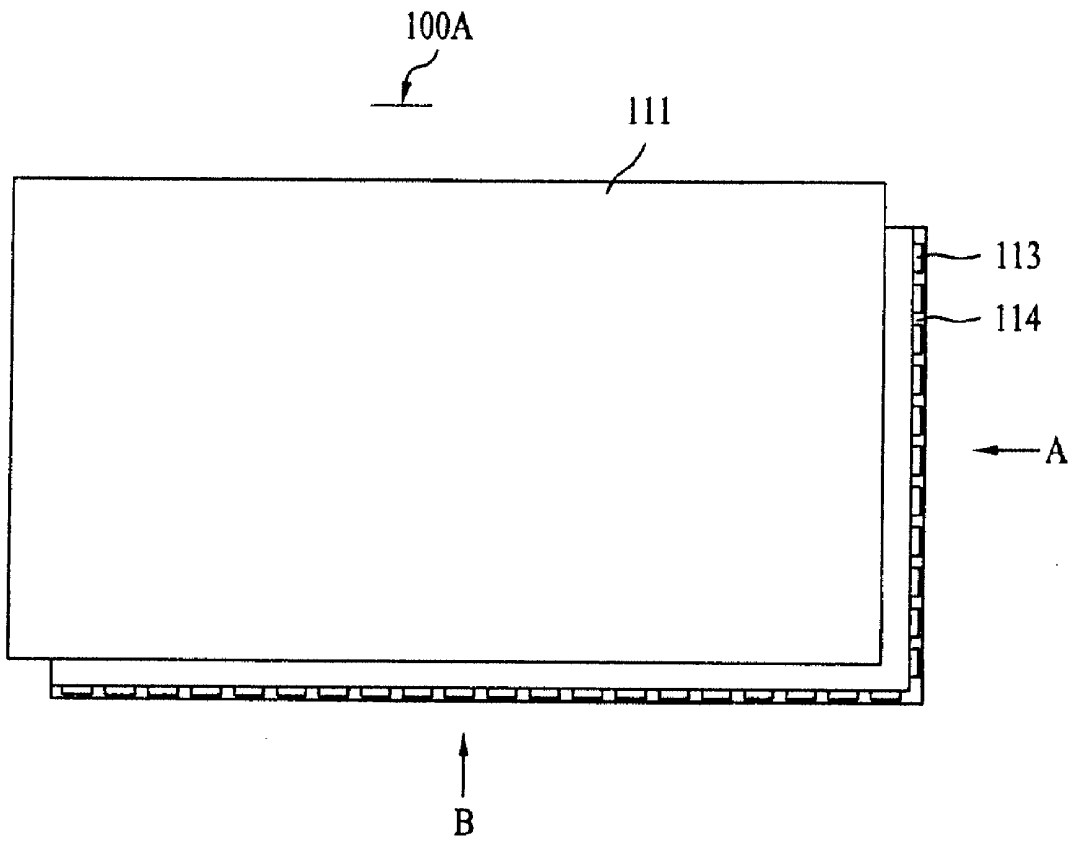

FIG. 6

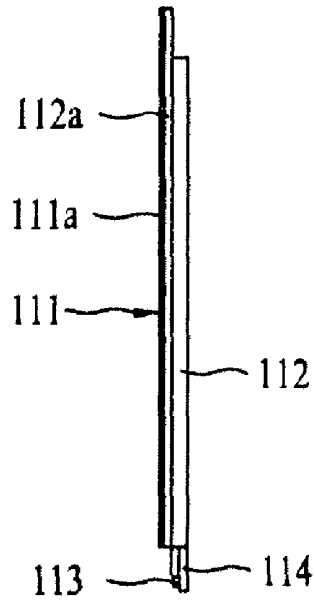

FIG. 7

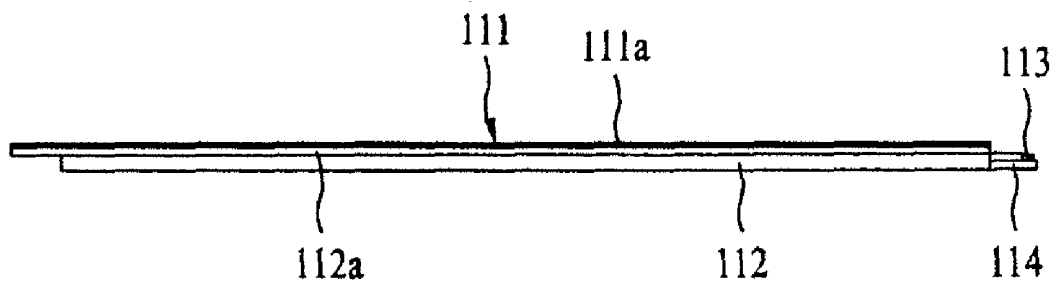

FIG. 8

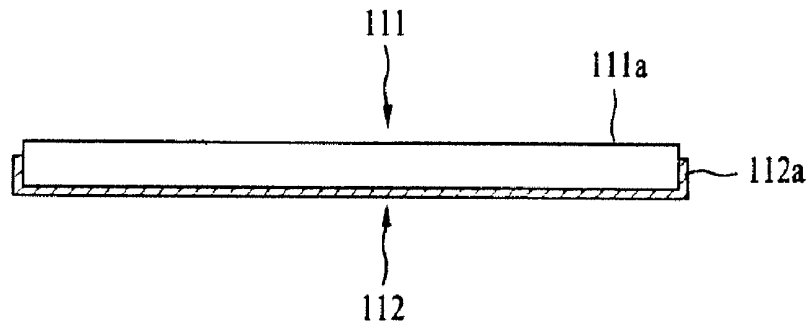

FIG. 9

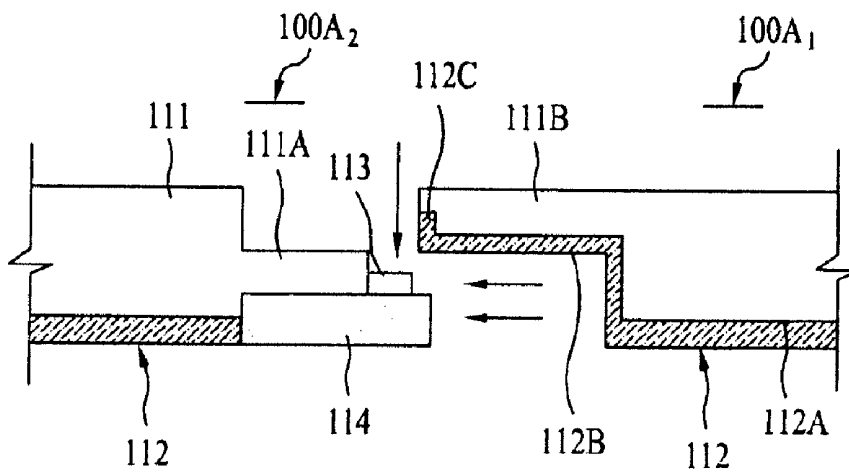

FIG. 10

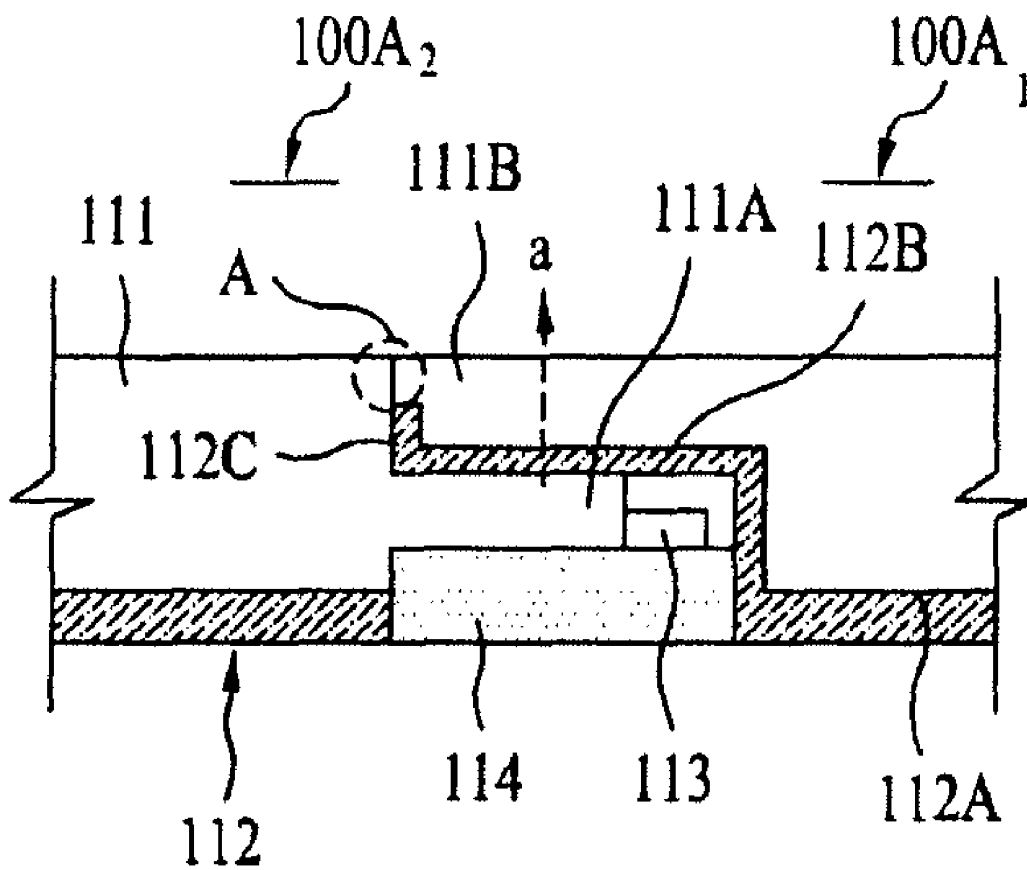

FIG. 11

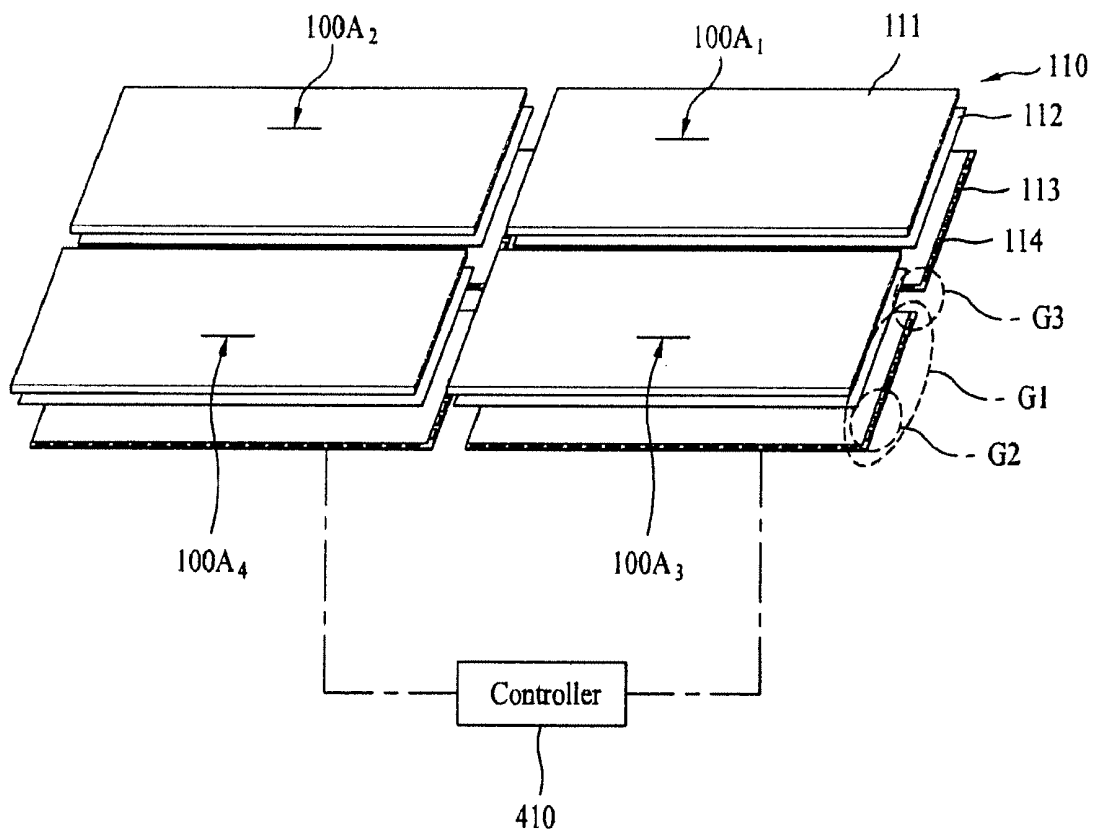

FIG. 12

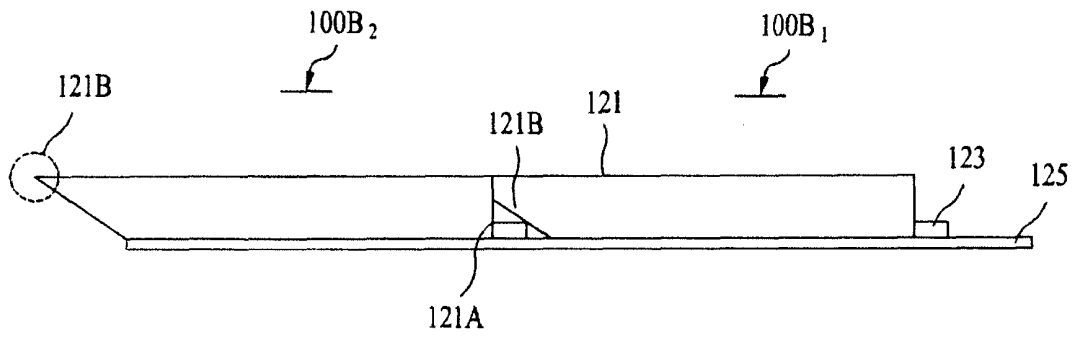

FIG. 13

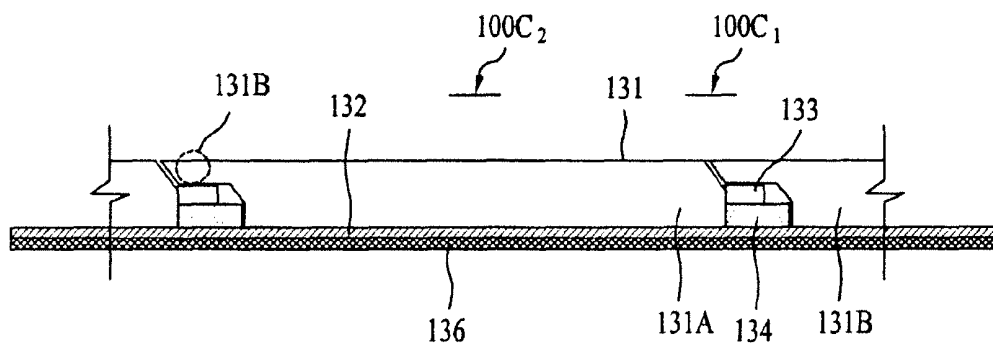

FIG. 14

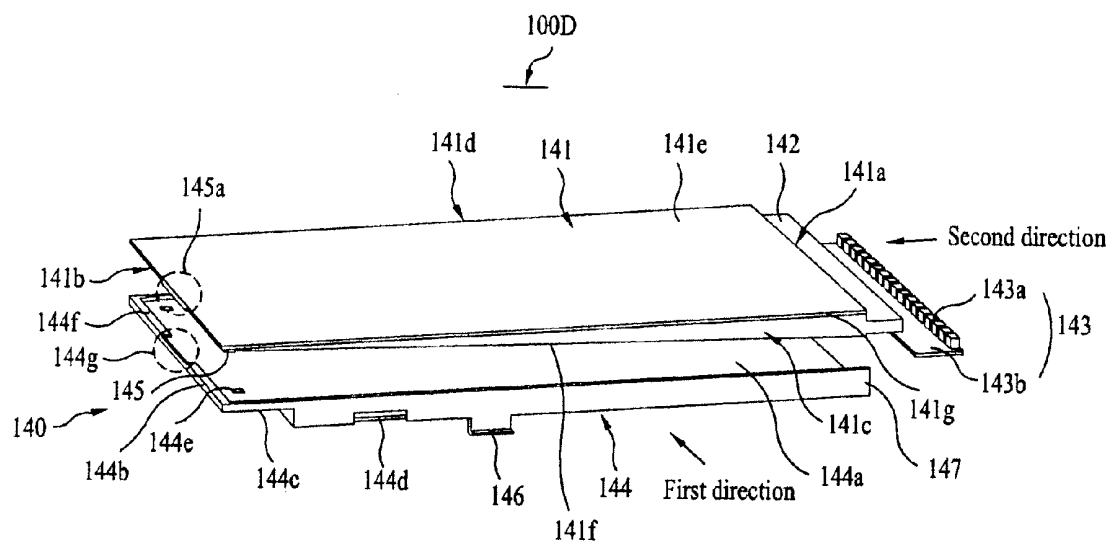

FIG. 15

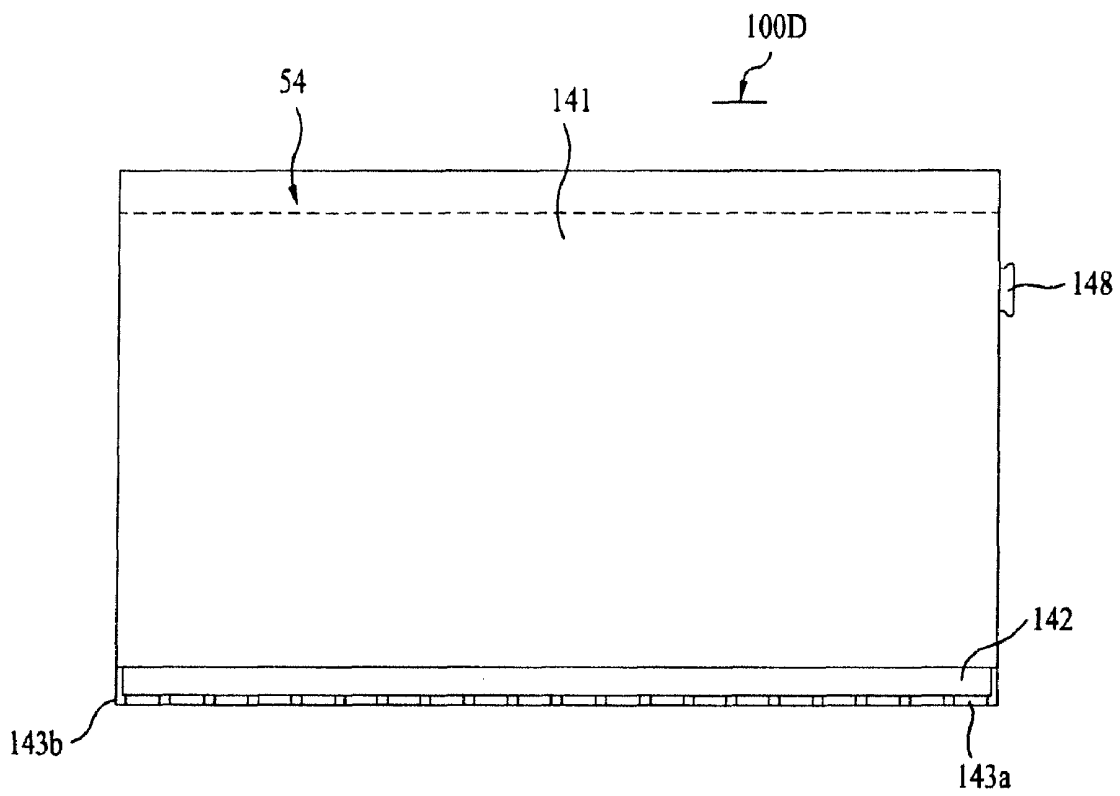

FIG. 16

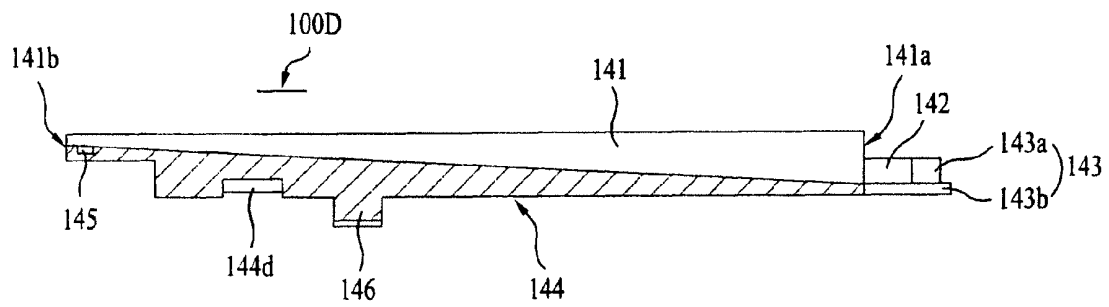

FIG. 17

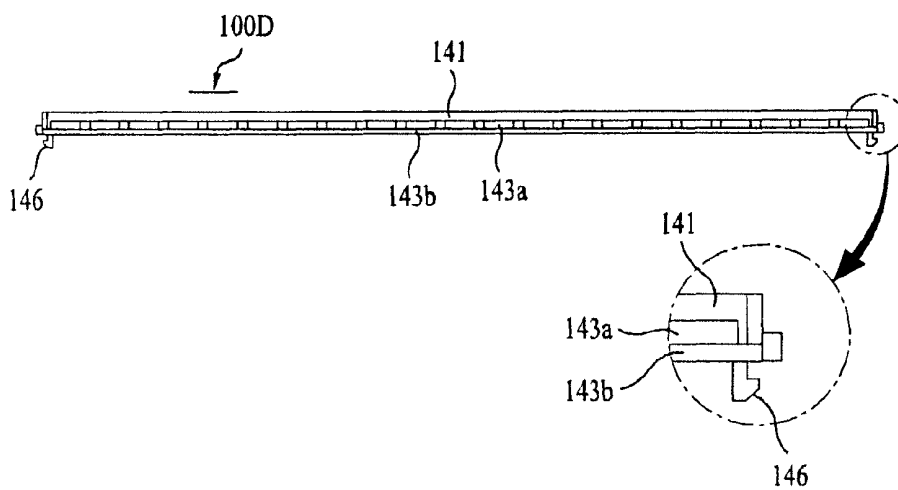

FIG. 18

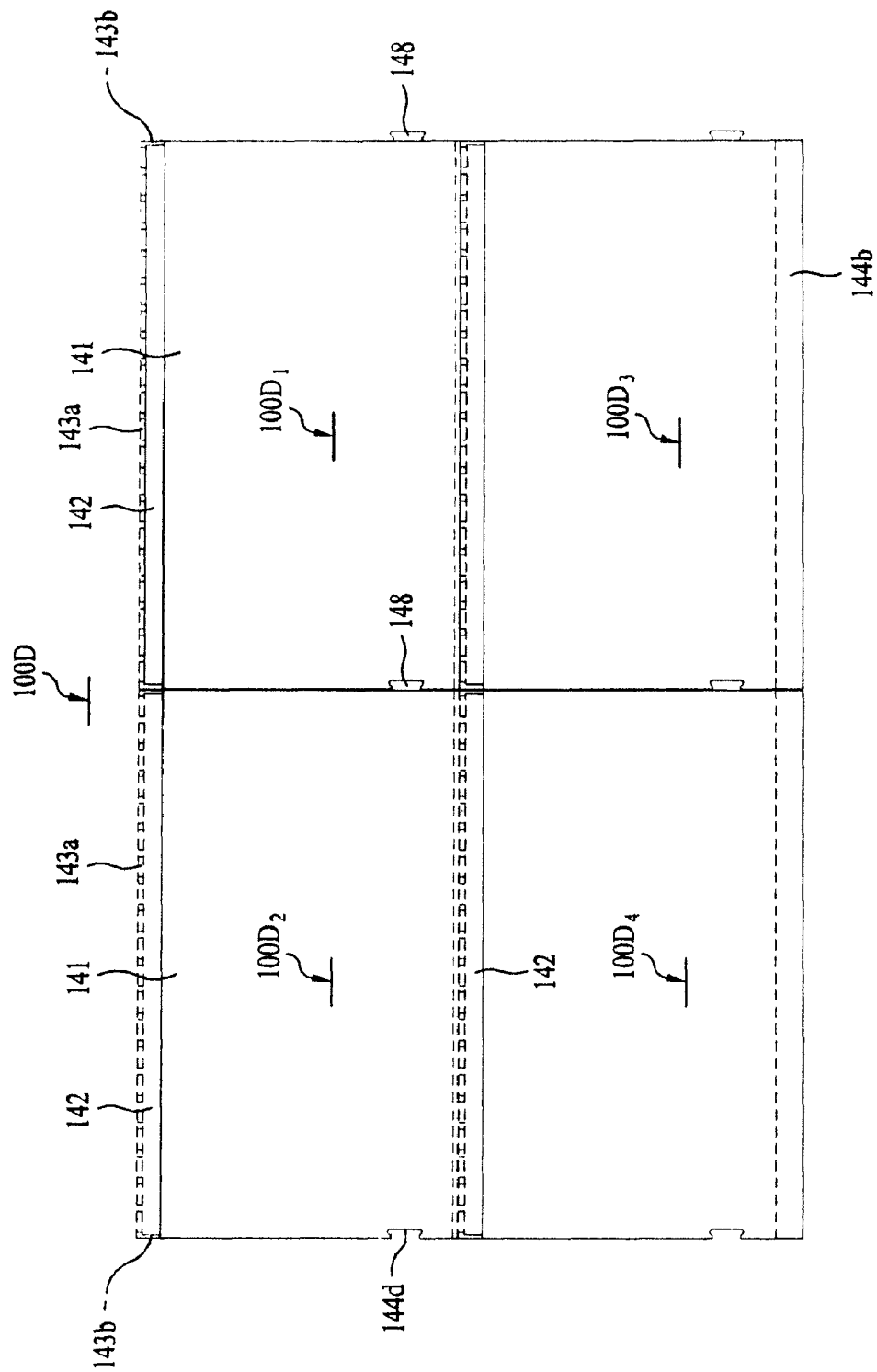

FIG. 19

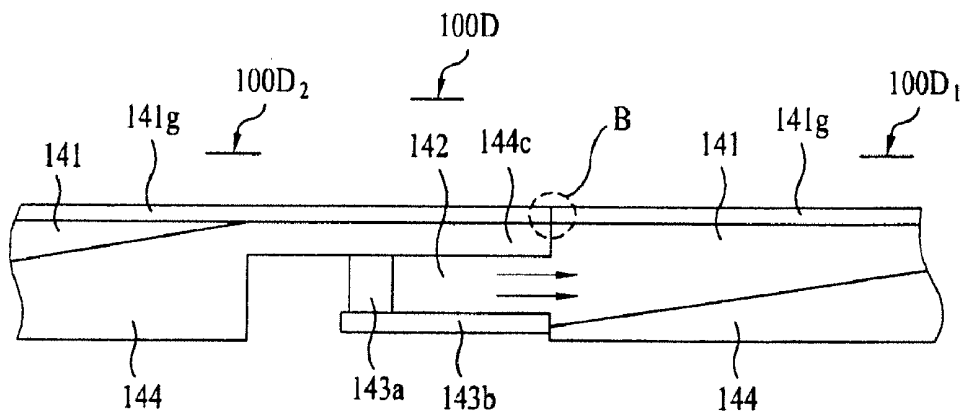

FIG. 20

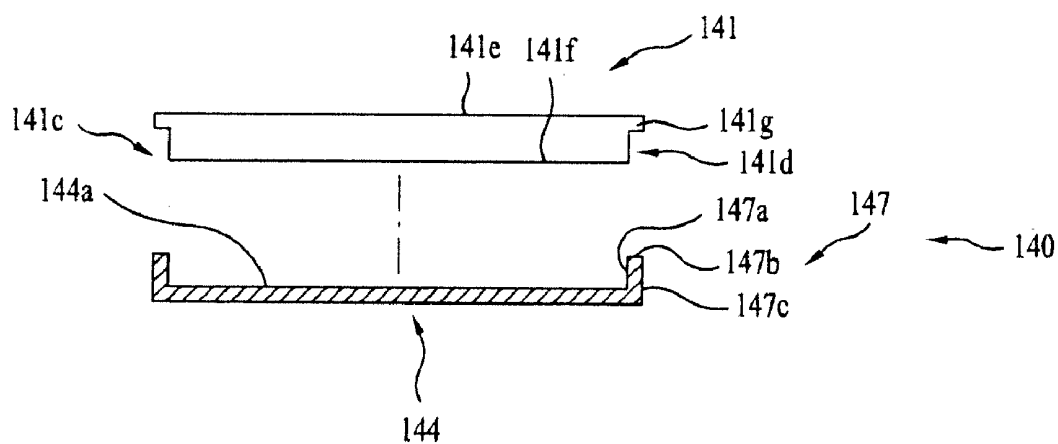

FIG. 22

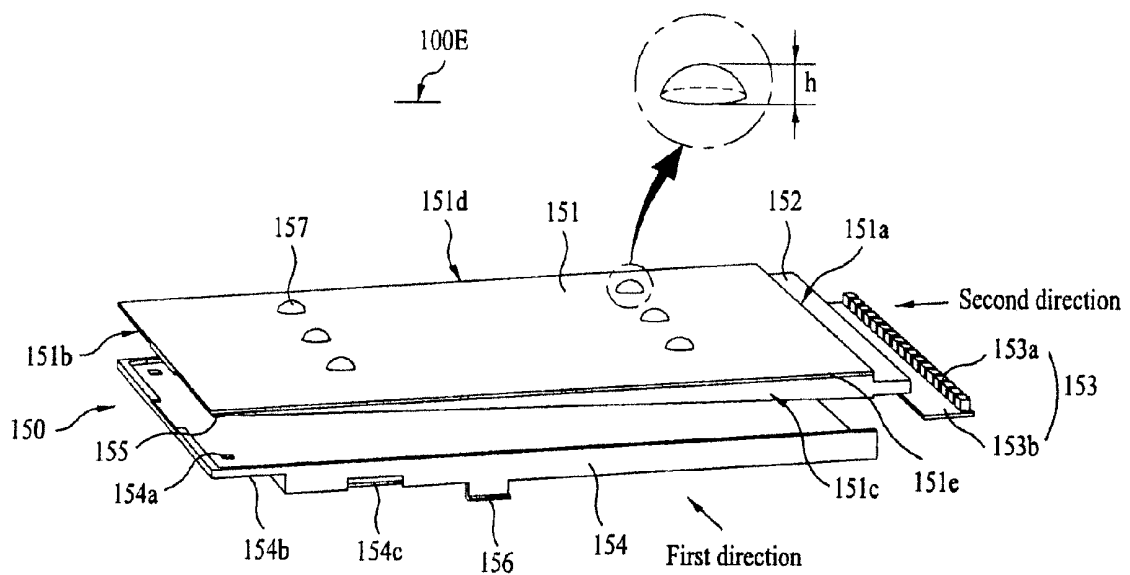

FIG. 23

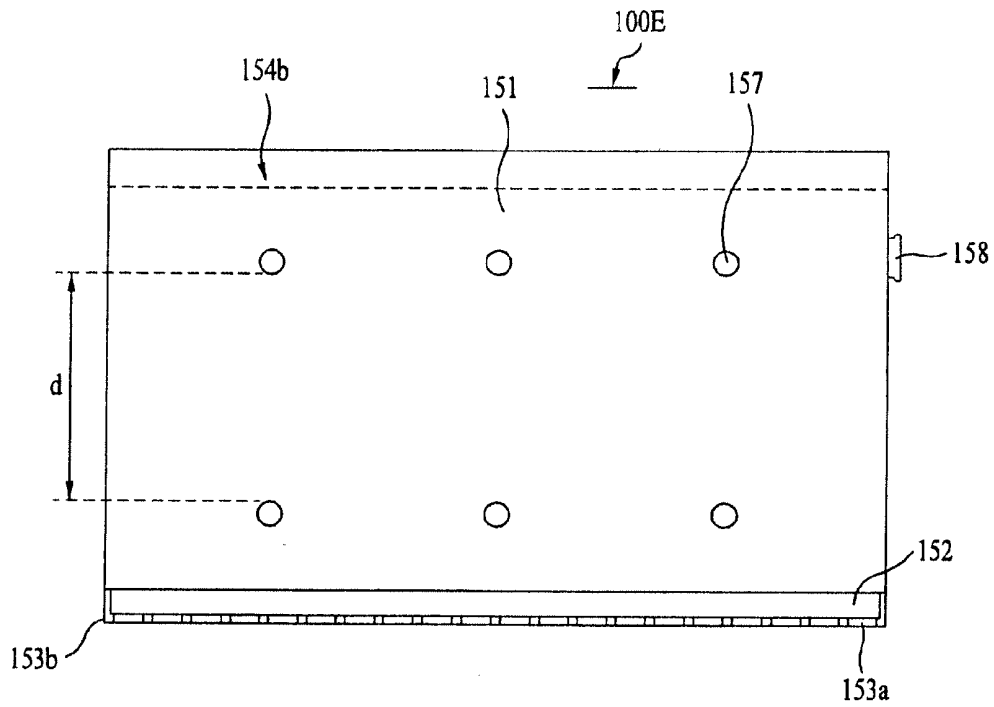

FIG. 24

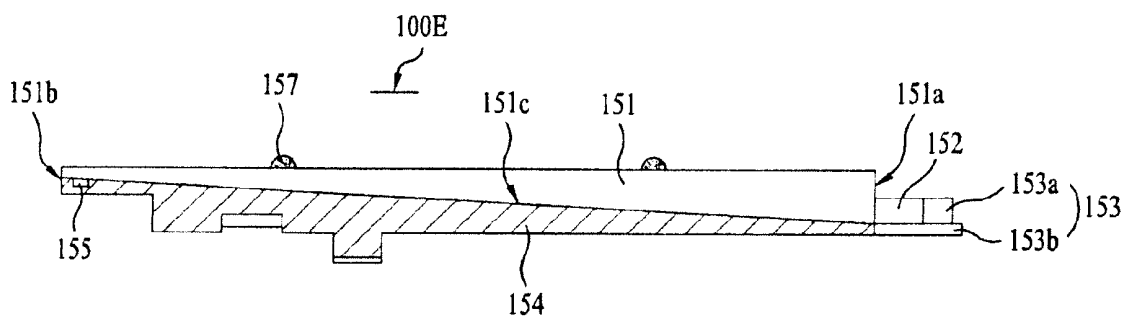

FIG. 25

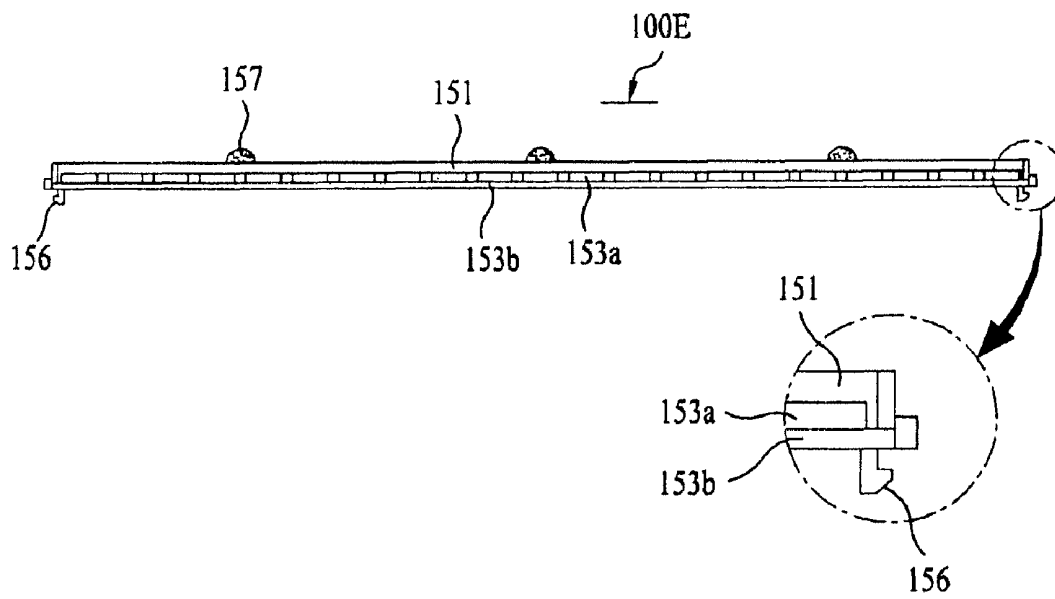

FIG. 27

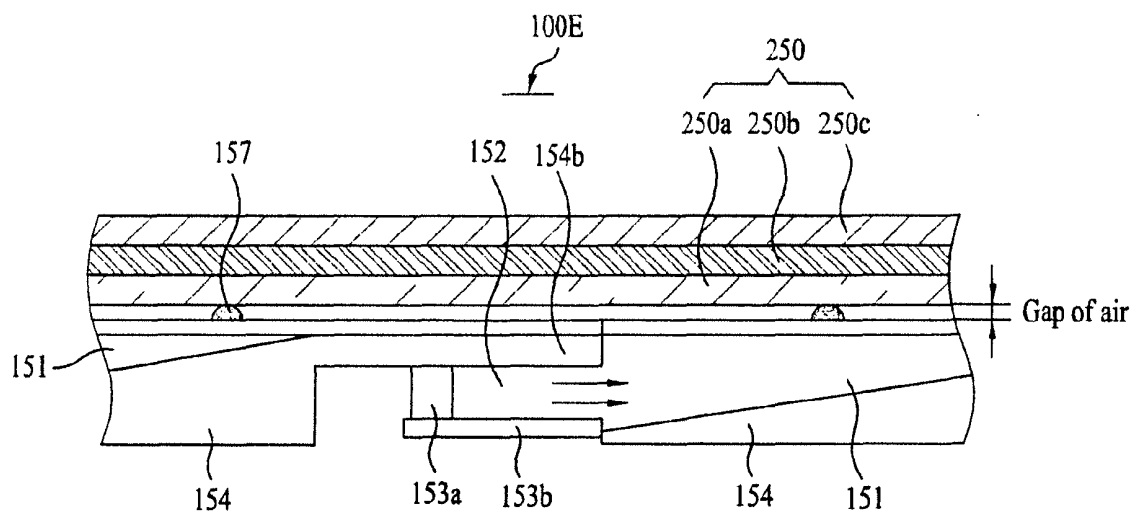

FIG. 28

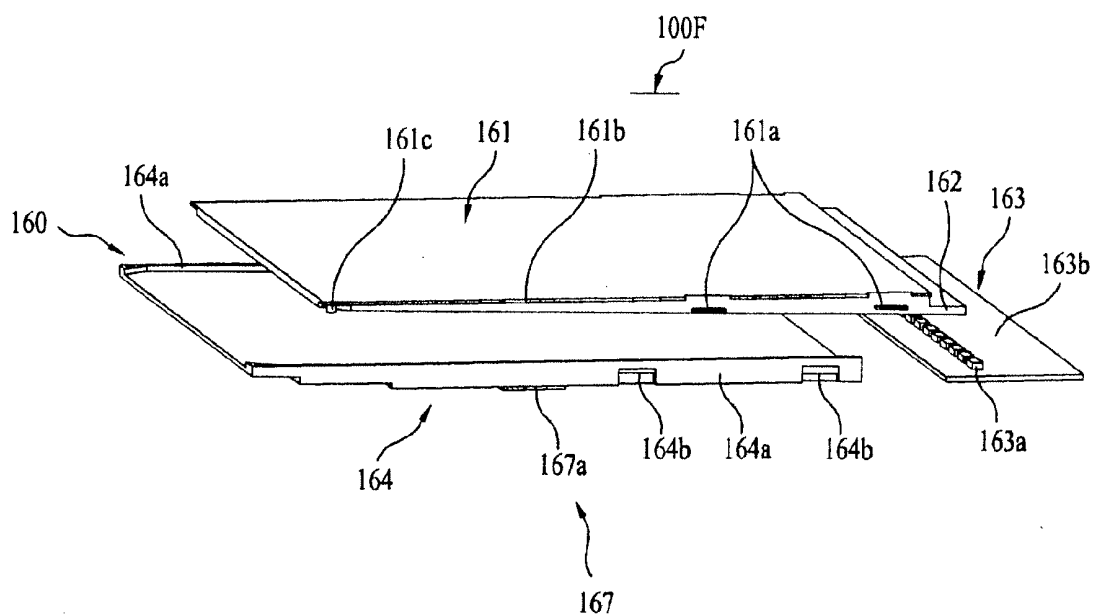

FIG. 29

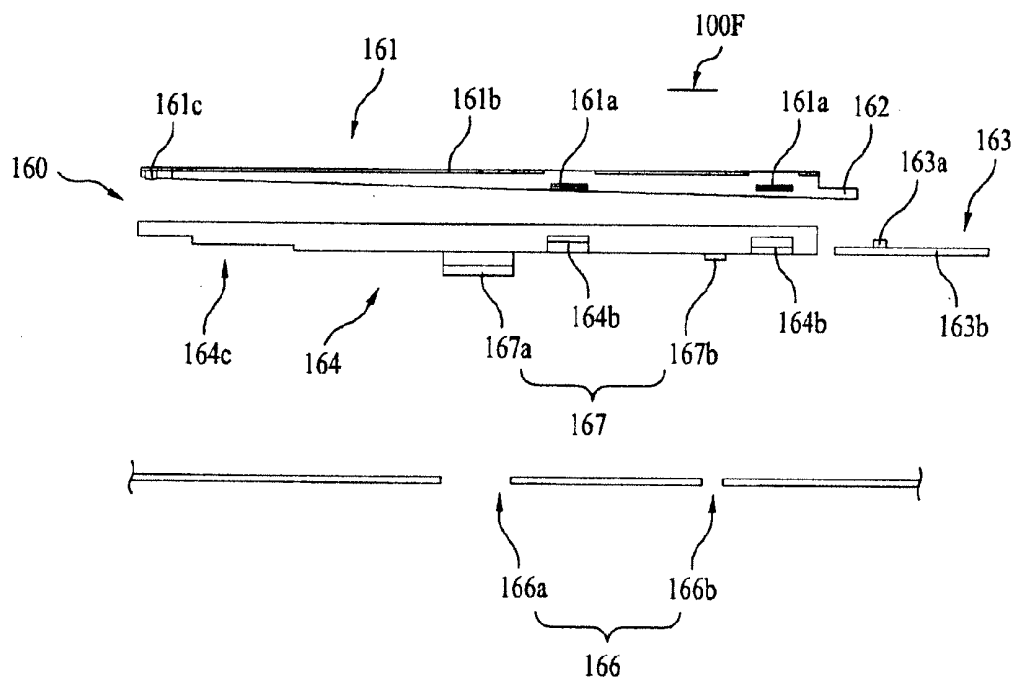

FIG. 30

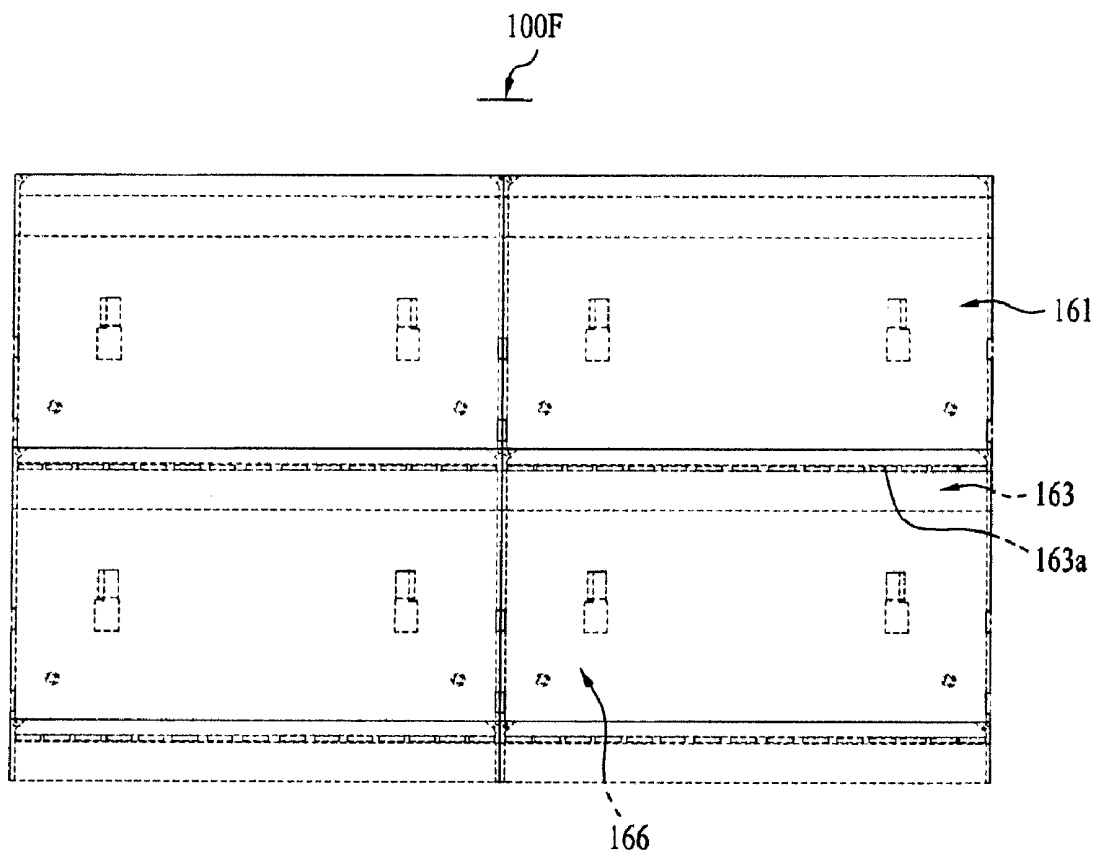

FIG. 31

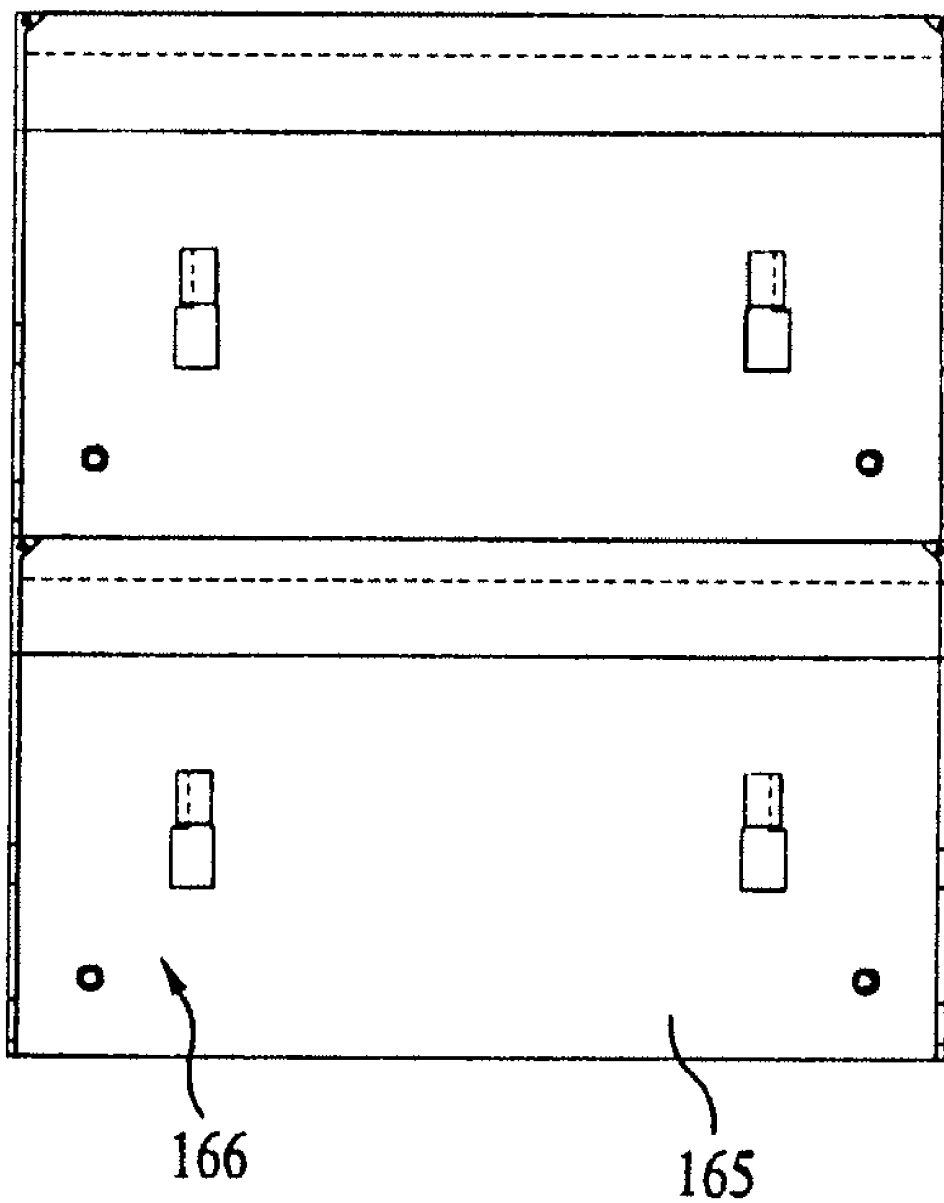

FIG. 32

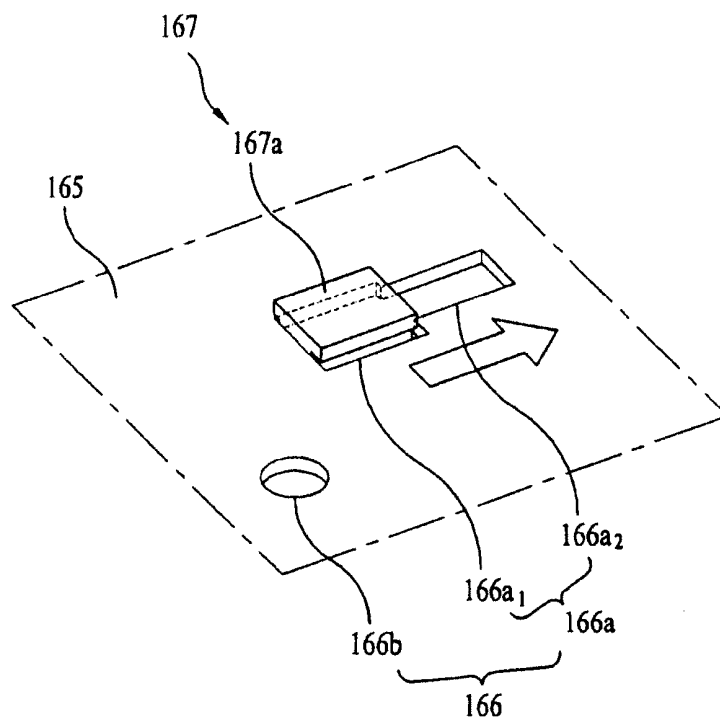

FIG. 33

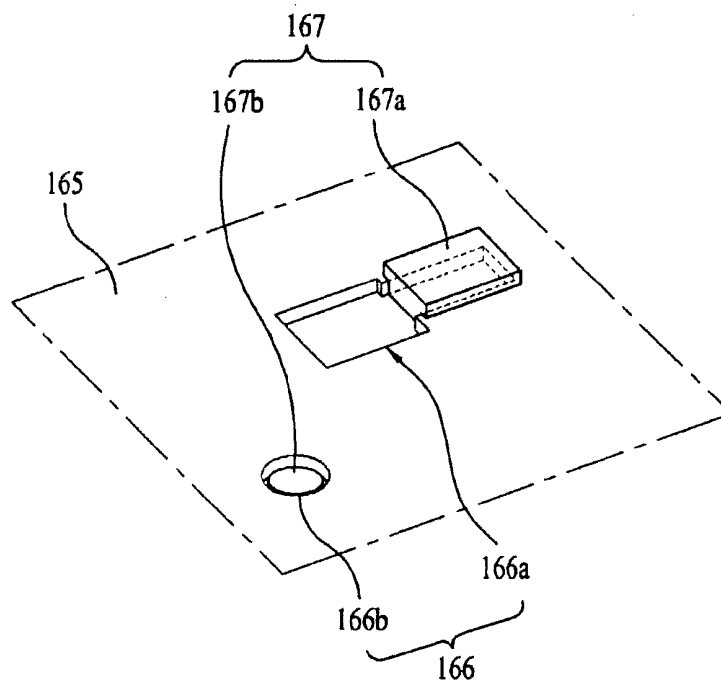

FIG. 34

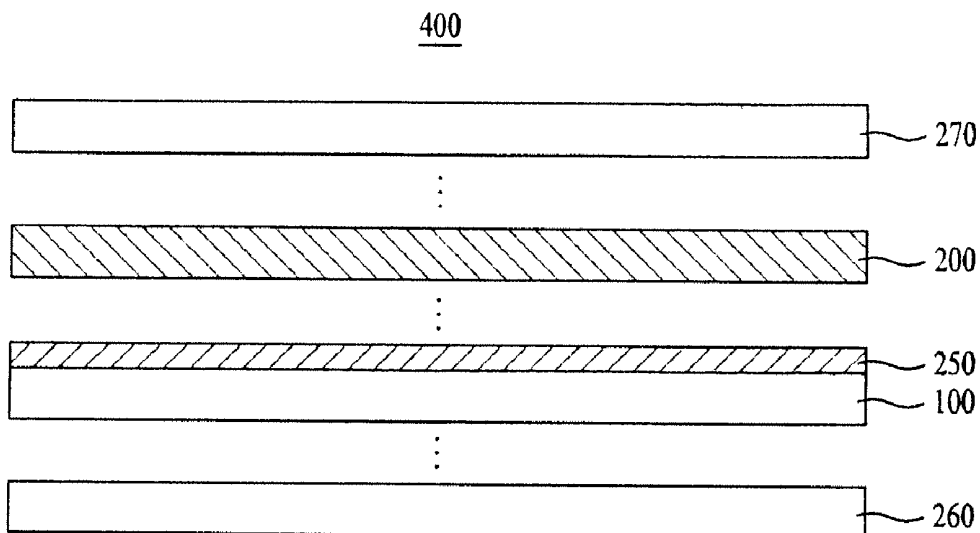

FIG. 35

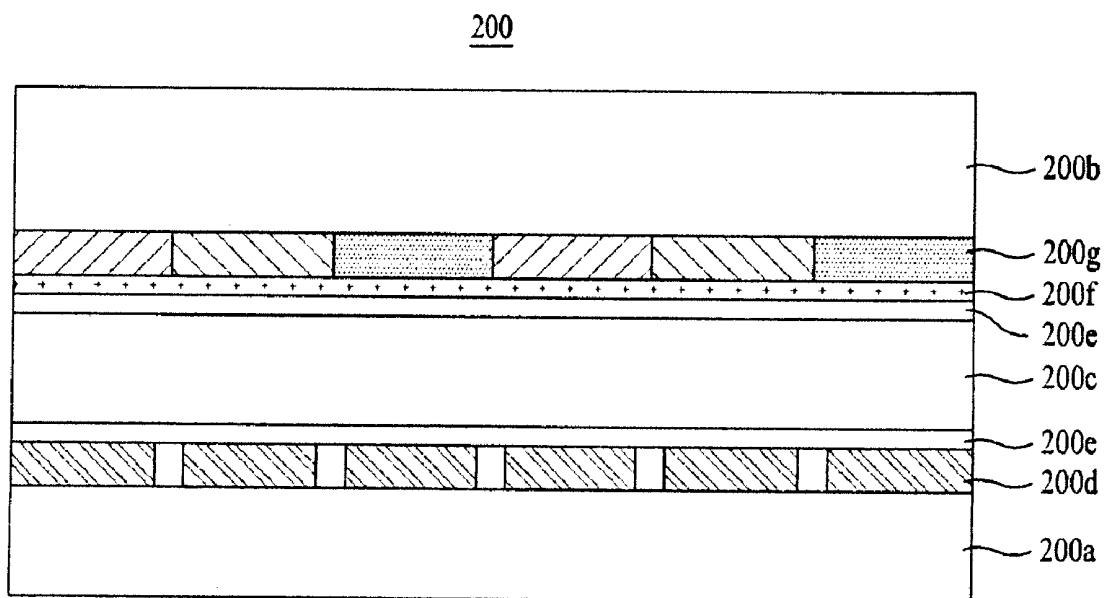
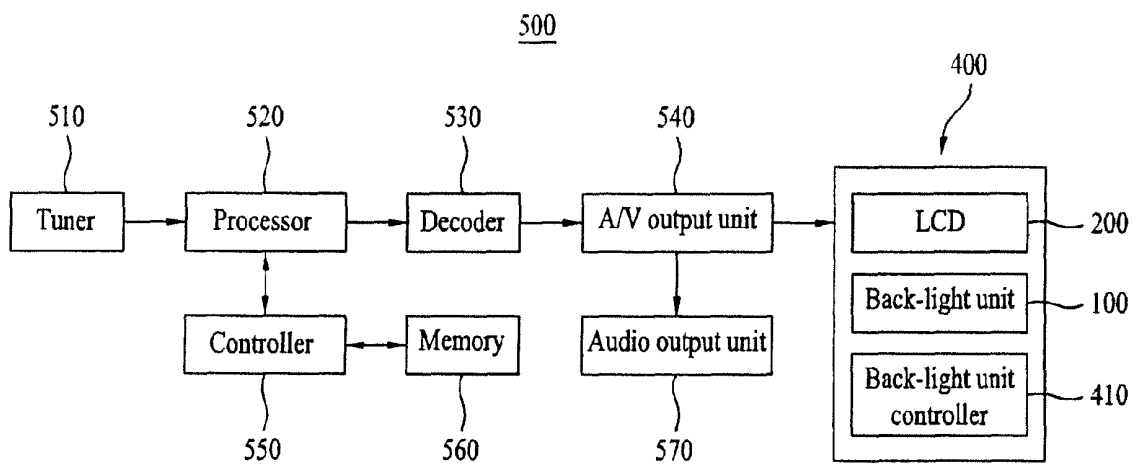

FIG. 36



**LED BACK-LIGHT UNIT AND LIQUID
CRYSTAL DISPLAY DEVICE USING THE
SAME**

CROSS REFERENCE TO RELATED
APPLICATION

This application claims the benefit of the Korean Patent Application No. 10-2008-0049146, filed on May 27, 2008, Korean Patent Application No. 10-2008-0061487, filed on Jun. 27, 2008, Korean Patent Application No. 10-2008-0099569, filed on Oct. 10, 2008, and Korean Patent Application No. 10-2009-0035029, filed on Apr. 22, 2009, which are hereby incorporated by reference as if fully set forth herein.

BACKGROUND OF THE DISCLOSURE

1. Field of the Disclosure

The present invention relates to an LED back-light unit and a liquid crystal display device using the same.

2. Discussion of the Related Art

In general, of display devices, LCD (Liquid Crystal Display Device) has various applications, starting from television sets, to laptop computers, monitors for desk top computers, and cellular phones.

Since the LCD can not emit a light for itself, in order to display image information, a light emitting device is required for illumination of a liquid crystal display panel.

Since the light emitting device for the LCD is coupled to a back side of the liquid crystal display panel, the light emitting device is called as a back-light unit that forms a facial light source for providing a light to the liquid crystal display panel.

A general back-light unit is provided with a light source, a light plate, diffusion sheets, a prism, a protective sheet, and so on. As the light source, fluorescent lamps, such as mercury cold cathode fluorescent lamps, light emitting diodes, or the like can be used.

SUMMARY OF THE DISCLOSURE

The present invention relates to an LED back-light unit. The present invention further relates to a liquid crystal display device using the same.

In one embodiment, an LED back-light unit includes a light guide portion that includes a light guide plate and a reflection plate coupled to the light guide plate, wherein the light guide plate has a light input part and a first connection part, and wherein the reflection plate has a second connection part connected to the first connection part, and a light source including at least one light emitting diode, the light source emitting light toward the light guide portion.

In another embodiment, a modular LED back-light unit includes a plurality of adjacent light guide portions, wherein each of the light guide portions includes a light guide plate having a light input part and a first connection part, and a reflection plate coupled to the light guide plate, the reflection plate having a second connection part connected to the first connection part, and a light source including at least one light emitting diode, the light source emitting light toward the light guide portion.

In one embodiment, a liquid crystal display device includes a liquid crystal display panel and a back-light unit, wherein the back-light unit includes, a plurality of adjacent light guide portions, wherein each of the light guide portions includes a light guide plate having a light input part and a first connection part, and a reflection plate coupled to the light guide plate, the reflection plate having a second connection part

connected to the first connection part, and a light source including at least one light emitting diode, the light source emitting light toward the light guide portion.

It is to be understood that both the foregoing general description and the following detailed description of the present invention are exemplary and explanatory and are intended to provide further explanation of the invention as claimed.

BRIEF DESCRIPTION OF THE DRAWINGS

The accompanying drawings, which are included to provide a further understanding of the disclosure and are incorporated in and constitute a part of this application, illustrate embodiment(s) of the disclosure and together with the description serve to explain the principle of the disclosure. In the drawings:

FIG. 1 illustrates a side view of a back-light unit in accordance with a first embodiment of the present invention, schematically.

FIG. 2 illustrates an exploded view of the back-light unit in FIG. 1.

FIG. 3 illustrates a side view of an assembly of a back-light unit in accordance with a first embodiment of the present invention, schematically.

FIG. 4 illustrates an exploded view of the assembly of the back-light unit in FIG. 3.

FIG. 5 illustrates an exploded view of a back-light unit in accordance with a first embodiment of the present invention.

FIG. 6 illustrates a side view of the back-light unit in FIG. 5 seen from A.

FIG. 7 illustrates a side view of the back-light unit in FIG. 5 seen from B.

FIG. 8 illustrates a section of a light guide portion.

FIGS. 9 and 10 illustrate steps of coupling of a light guide portion in accordance with a first embodiment of the present invention, schematically.

FIG. 11 illustrates an exploded perspective view showing coupling of back-light unit modules in accordance with a first embodiment of the present invention.

FIG. 12 illustrates a side view of a back-light unit in accordance with a second embodiment of the present invention, schematically.

FIG. 13 illustrates a side view of a back-light unit in accordance with a third embodiment of the present invention, schematically.

FIGS. 14-21 illustrate diagrams each showing a structure of a back-light unit in accordance with a fourth embodiment of the present invention.

FIGS. 22-27 illustrate diagrams each showing a structure of a back-light unit in accordance with a fifth embodiment of the present invention.

FIGS. 28-33 illustrate diagrams each showing a structure of a back-light unit in accordance with a sixth embodiment of the present invention.

FIG. 34 illustrates an exploded view of an exemplary liquid crystal display device having a back-light unit in accordance with a seventh embodiment of the present invention applied thereto.

FIG. 35 illustrates a section of an exemplary liquid crystal display panel in accordance with a seventh embodiment of the present invention.

FIG. 36 illustrates a block diagram of a liquid crystal TV set having a liquid crystal display device in accordance with an eighth embodiment of the present invention applied thereto.

DESCRIPTION OF SPECIFIC EMBODIMENTS

Reference will now be made in detail to the specific embodiments of the present invention, examples of which are illustrated in the accompanying drawings. Wherever possible, the same reference numbers will be used throughout the drawings to refer to the same or like parts.

The terms “module”, “portion”, and “part” on elements of the present invention used in description hereafter are ones given or used together with others only taking easiness of writing the specification into account, and are not distinctive in definitions between themselves, or in functions.

Though the present invention has variations and modifications, specific embodiment thereof will be illustrated with drawings. However, the present invention is not intended to limit the present invention to a specific one disclosed herein, and contrary to this, the present invention includes all modifications, substitutions, equivalences thereof in agreement of the aspect of the present invention defined by the claims of the present invention.

In a case it is described that an element, like a layer, a region, or a substrate, is “on” other element, it is understandable that the element is on the other element directly, or there may be another intermediate element between the two elements.

It will be understood that the words intend to include other directions in addition to a direction described in the drawings. Finally, the word of ‘directly’ means that there is no other element disposed inbetween. The words of ‘and/or’ as is used herein include one or more than one or all combinations of written items.

It will be also understood that although the terms first, second, and so forth are used herein to describe various regions, layers and/or sections, these regions, layers and/or sections should not be limited by these terms.

<A First Embodiment>

FIG. 1 illustrates a side view of a back-light unit in accordance with a first embodiment of the present invention schematically, and FIG. 2 illustrates an exploded view of the back-light unit in FIG. 1.

Referring to FIGS. 1 and 2, the back-light unit 100A includes a light guide plate 111, a reflection plate 112 on an underside of the light guide plate 111, and a light source 113. The light guide plate 111 and the reflection plate 112 together may be called as a light guide portion 110 or a light guide plate module 110.

As for the light source 113, light emitting diodes (LEDs) may be used, the light guide plate 111 includes a light input part 111A formed at a portion of the light guide plate 111 where a light is incident thereto from the LED 113, and the other side (opposite to the light input part 111A) edge 111B which is stepped.

Referring to FIGS. 1 and 2, the light input part 111A is projected from the light guide plate 111 in a side direction, and, if the light input part 111A is projected from the light guide plate 111 in the side direction thus, the LEDs 113 can be arranged at an edge of the light input part 111A on the circuit board 114.

The reflection plate 112 on the light guide plate 111 is on the underside of the light guide plate 111 and an underside of the other edge 111B of the light input part 111A. In addition to this, the reflection plate 112 may cover sides of the light guide plate 111.

The LED 113 and the circuit board 114 may be positioned on a first side which is a light input part 111A side of the light guide plate 111, or on the first side and a second side which is

substantially perpendicular to the first side such that the light is incident to the light guide plate 111 from the LED 113 in two directions.

A plurality of the light guide portions 110 each including the light guide plate 111 and the reflection plate 112 shown in FIGS. 1 and 2 may be arranged as shown in FIGS. 3 and 4 to form a full set of a back-light unit 100A₁ or 100A₂.

For convenience’s sake, referring to FIGS. 3 and 4, a right side back-light unit 100A will be called as a first module A₁, and a left side back-light unit 100A will be called as a second module A₂.

Referring to FIGS. 3 and 4, the first module 100A₁ and the second module 100A₂ are coupled such that the other edge 111B opposite to the light input part of the first module A₁ covers the light input part 111A of the second module A₂.

This is for preventing the light from the LED 113 at the light input part 111A of the first module 100A₁ from leaking to an outside of the back-light unit.

By arranging the other edge 111B of the first module 100A₁ coupled to the light input part 111A of the second module 100A₂, a function of the light guide plate 111 as well as a function of covering the LED 113 of the second module 100A₂ can be performed. That is, the light from the LED 113 of the second module 100A₂ is not exposed, directly.

Owing to above configuration, the light from the second module 100A₂ advances along a side of the light guide plate 111 of the second module A₂, and comes out of an outside surface of the light guide plate 111 uniformly.

The reflection plate 112 of the second module 100A₂ can improve light efficiency of the light comes out of the outside surface of the light guide plate 111 thus. That is, the light from the LED 113 of the second module A₂ advances along the side of the light guide plate 111A, and the reflection plate 112 of the first module 100A₁ over the light input part 111A adjacent to the light input part 111A assists such advance of the light.

By arranging the back-light units 100A each having the light guide plate 111 and the reflection plate 112 of the first embodiment in a tiling fashion, a large sized back-light unit 100A can be fabricated, which can be used in TV sets, sign boards with lamps, and so on.

Thus, by projecting the light input part 111A from a light forwarding surface extensively, relatively dark portions shown on a portion caused by gaps between each of the LEDs 113 can be decreased, and direct leakage of the light from the LEDs 113 through connected portion between each of the light guide plates 111 can be prevented or substantially reduced.

Though the light can transmit from one light guide plate 111 to an adjacent light guide plate 111 through the other edge 111B of the light input part 111A, by not placing the reflection plate 112 between the adjacent light guide plates 111 to shield the light transmission completely, but by permitting the light to transmit through the adjacent light guide plates 111, formation of the relatively dark portions (shadow images) caused by a step between the light input part 111A and the adjacent edge 111B of the light guide plate 111 can be prevented or substantially reduced.

FIGS. 5 to 7 illustrate the back-light unit in more detail, each showing a state in which the LED 113 on the circuit board 114 is in contact with the light guide plate 111.

Referring to FIGS. 6 and 7, the reflection plate 112 is arranged, not only on an underside of the light guide plate 111, but also on sides of light guide plate 111 as a rim 112a of the reflection plate 112 such that a portion of the light guide plate 111 is exposed and rest of the light guide plate 111 is covered by the rim 112a. That is, a section as shown in FIG. 8 is made.

Or, depending on cases, the reflection plate **112** may be folded at the sides of the light guide plate **111** more than one time.

Coupling to the modules **100A₁** and **100A₂** can be made as shown in FIGS. **9** and **10**.

That is, in a state the LED **113** of the second module **A₂** is coupled to the light input part **111A** of the light guide plate **111** with the LED **113** in contact with the light input part **111A**, the edge **111B** of the first module **A₁** is coupled to the light input part **111A** of the second module **A₂** adjacent thereto.

According to this, the edge **111B** of the first module **100A₁** having the reflection plate **112** attached thereto is positioned over the LED **113** of the second module **A₂**, such that the light from the LED **113** of the second module **A₂** is not exposed to an upper side, but incident on the light input part **111A**, transmits through the light guide plate **111** and comes out of the light guide plate **111**.

In this instance, the reflection plate **112B** on the underside of the other edge of the light input part **111A** and an edge **112C** of the reflection plate **112B** extended therefrom can shield at least a portion of the light guide plate **111**, optically.

In other words, though the first module **A₁** and the second module **A₂** are coupled together optically, enabling the light to transmit from the second module **100A₂** to the first module **A₁**, and vice versa, a portion of the light can be shielded.

That is, a portion of the light from the second module **A₂** to the edge **111B** of the first module **A₁** can be shielded by the edge **112c** of the reflection plate of the first module **100A₁**, at least preventing a brighter line from forming at a boundary of the modules **A₁** and **A₂**. However, adjacent modules are made to be connected with a connection portion **A** over the edge **112c** of the reflection plate optically, formation of a relatively dark line can be prevented or decreased.

Referring to FIG. **11**, by arranging a plurality of the modules **100A₁**, **100A₂**, **100A₃**, and **100A₄** each having the light guide plate **111** and the reflection plate **112**, a set of a back-light unit **100A** can be fabricated.

The circuit board **114** and the LEDs **113** are arranged on one or two sides of the light guide portion **110**, and a plurality of the modules **100A₁**, **100A₂**, **100A₃**, and **100A₄** each having the light guide plate **111** and the reflection plate **112**, to fabricate a set of a back-light unit **100A**.

The back-light unit **100A** having the plurality of the modules **100A₁**, **100A₂**, **100A₃**, and **100A₄** or the plurality of the LEDs connected thereto may be driven by a controller **410** independently or in groups with the back-light unit **100A** divided into groups of predefined number of LEDs depending on cases, enabling to reduce power consumption, significantly.

That is, the controller **410** independently controls the brightness of the light source (LEDs) **113** of each of the light guide portions **110**.

The brightness of the light source **113** of each of the light guide portions **110** is controlled according to image data associated with the light source **113**. The image data is in relation to images displayed on a display panel, such as a liquid crystal display panel. For example, if the image data has dark images, a group of light source **113** in relation to the dark images can be turned out or dimmed, and if the image data has bright images, a group of light source **113** in relation to the bright images can be driving more brightly. As a result, the contrast ratio of the images is increased or improved.

In this instance, the unit of driving by the controller **410** may be a set of all LEDs in an individual module, an individual LED, or a set of LEDs grouped within each of the module (logical group).

That is, the LEDs may be driven as a unit of a group of all LEDs set **G1** located along a side of each module, or as a unit of a sub group of LED set **G2** within the set **G1**. In some case, the unit can be a logical group **G3** (as a unit of driving) which comprises LEDs (or an LED) located in a module **100A₁** and LEDs (or an LED) located in the adjacent module **100A₂**.

In other words, the light source **113** of the light guide portion **110** includes groups (**G1**, **G2**, or **G3**) of LEDs, and the controller **410** independently controls brightness of each group of the LEDs **113**.

Thus, as described, in the back-light unit in accordance with the first embodiment of the present invention, small sized light guide plates are formed, and the LEDs are attached to a side of each of the light guide plates, for securing a light quantity and dispersing heat, and particularly, LEDs at the side of the light guide plate can be hidden, optically.

Moreover, the back-light unit in accordance with the first embodiment of the present invention permits to arrange the LEDs between the light guide plates as an entire area of the display can be covered with the small sized light guide plate modules, and to use the same light guide plate regardless of a size of the display.

In the meantime, fabrication of the large sized display by connecting the light guide plates fabricated as modules piece by piece in a tiling fashion enables to standardize parts since the same part can be applied to various sized TV sets by varying a number of modules only.

<A Second Embodiment>

Referring to FIG. **12**, the back-light unit **100B** in accordance with a second embodiment of the present invention includes a light guide plate **121**, a back panel (or a frame) **125** under the light guide plate **121** and a light source **123**.

A plurality of modules **100B₁** and **100B₂** each having the light guide plate **121** of the second embodiment are arranged on a plane to form a full set of the back-light unit **100B**.

For convenience's sake, a right side module **100B** will be called as a first module **100B₁**, and a left side module **100B** will be called as a second module **100B₂**.

That is, a back light portion **121B** of the light guide plate **121** of the first module **100B₁** is coupled to a light input part **121A** of the second module **100B₂** adjacent thereto in a position of covering the light input part **121A**. This is for preventing the light from the LED **123** at the light input part **121A** of the second module **100B₂** adjacent thereto from leaking to an outside of the back-light unit.

In order to connect the light guide plate **121** of the first module **100B₁** and light guide plate **121** of the second module **100B₂** adjacent thereto in a tiling fashion, the LED **123** is located on a lower side of a connection portion, i.e., on a lower side of an edge **121B** of the light guide plate **121**.

Therefore, it is provided to secure a space for placing the LED **123**, which may be selected according to optical characteristics of a structure of the light guide plate **121**.

That is, referring to FIG. **12**, different from the first embodiment, the edge **121B** of the light guide plate **121** is triangular, and the LED **123** may be placed on the lower side of the edge **121B**. In this instance, instead of a separate circuit board, the light guide plate **121** and the LED **123** may be mounted to one frame **125** having circuits formed thereon.

Parts not explained herein may be identical to the first embodiment.

<A Third Embodiment>

Referring to FIG. **13**, a back-light unit **100D** in accordance with a third embodiment of the present invention includes a light source portion **130** having a light guide plate **131** and a reflection plate **132** on an underside of the light guide plate

131, a light source **133**, and a circuit board **134** having the light source **133** mounted thereto.

Referring to FIG. 13, there are a plurality of modules **100C₁** and **100C₂** each having the light guide plate **131** arranged on a plane to form a full set of a back-light unit **100C**.

Referring to FIG. 13, for convenience's sake, a right side back-light unit **100C** will be called as a first back-light unit **100C₁** and a left side back-light unit **100C** will be called as a second back-light unit **100C₂**.

In order to connect the light guide plate **131** of the first back-light unit **100C₁** to the light guide plate **131** of the second module **100C₂** in a tiling fashion, the LED **133** is located on a lower side of a connection portion, i.e., on a lower side of the edge **131B**.

According to this, it is provided to secure a space for placing the LED **133** therein, by selecting the space according to optical characteristic of a structure of the light guide plate **131**.

The structure may have a sloped back light portion **131B** of the first module **100C₁** in contact with the second module **C₂**. In this instance, the LED **133** is mounted to a separate circuit board, and the reflection plate **132** and the frame **136** may be positioned under the light guide plate **131**.

<A Fourth Embodiment>

Referring to FIGS. 14 to 17, the back-light unit **100D** in accordance with a fourth embodiment of the present invention includes a light guide plate **141**, a light source **143**, and a reflection plate **144**. Parts unexplained herein may have things identical to foregoing embodiments applied thereto.

The light guide plate **141** and the reflection plate **144** together may be called as a light guide portion **140** or a light guide plate module **140**.

The light guide plate **141** has a flat upper side, a sloped lower surface, and a side having a light input part **142** formed thereon.

The light guide plate **141** has opposite first side **141a** and a second side **141b**, and opposite third side **141c** and fourth side **141d**. The third side **141c** and the fourth side **141d** are sides substantially perpendicular to the light input part **142**. The light guide plate **141** has an underside surface **141f** spaced from or in contact with a light forwarding surface **141e** and the reflection plate **144**.

The light guide plate **141** has a thickness which becomes the thinner as the thickness goes from the first side **141a** to the second side **141b** the more, forming the underside of the light guide plate **141** to be sloped, partially or entirely.

The light input part **142** at the first side **141a** of the light guide plate **141** may have a thickness thinner than a thickness of the first side **141a** of the light guide plate **141**. According to this, an upper side of the light input part **142** and an upper side **141e** of the light guide plate **141** are positioned on planes different from each other.

Depending on cases, in order to transmit the light sufficiently uniformly throughout the light guide plate **141**, a portion of a lower side of the light input part **142** may be formed unevenly.

An upper side of the circuit board **143b** of the light source **143** coupled to the underside of the light input part **142** may also be formed unevenly at the same position.

The reflection plate **144** has a rim **147** substantially perpendicular to the light source **143**, which may be coupled to at least a portion of the third side **141c** and the fourth side **141d** of the light guide plate **141**.

The light guide plate **141** may have at least one fastening protrusion **145** protruding from an underside periphery as a fastening member for fastening to an upper side **144a** of the reflection plate **144**.

The fastening protrusion **145** is placed in a fastening recess **144e** in the upper side of the reflection plate **144** for maintaining a position even against an external impact or vibration.

As a member for fastening the light guide plate **141** to the reflection plate **144**, the light guide plate **141** may have a supplementary (or auxiliary) protrusion **145a** from the second side **141b** and the reflection plate **144** may have a cut-off portion **144g** formed in conformity with the supplementary protrusion **145a**.

In the meantime, the light source **143**, positioned at a side of the light input part **142** for emitting a light to the light input part **142**, may include at least one LED **143a** and a circuit board **143b**.

The LED **143a** is positioned at a side of the light input part **142** for generating and emitting the light to the light input part **142**. The circuit board **143b** may be coupled to and support undersides of the LED **143a** and the light input part **142**.

Thus, by projecting the light input part **142** from the side of the light guide plate **141**, relatively dark portions between the LEDs **143a** can be eliminated or decreased, and direct leakage of the light through connection portion between modules **100D** can be prevented.

The reflection plate **144** is coupled to the underside **141f** of the light guide plate **141** for reflection of the light to the light guide plate **141**, and may cover at least a portion of the second to fourth sides **141b**, **141c**, and **141d** of the light guide plate **141** for preventing the light from transmitting to an outside of the back-light unit or an adjacent light guide plate from the light guide plate **141** at least partially.

Referring to FIG. 16, an upper side **144a** of the reflection plate **144** has a slope opposite to the slope of the underside **141f** of the light guide plate **141**.

Accordingly, if the reflection plate **144** is placed on the light guide plate **141** such that the upper side **144a** of the reflection plate **144** couples to the underside **141f** of the light guide plate **141**, the underside of the reflection plate **144** and the upper side **141e** of the light guide plate **141** are parallel to each other.

That is, the reflection plate **144** has opposite first and second sides, and has a thickness which becomes the thicker as the thickness goes from the first side to the second side the more.

The light source **143** is positioned at the first side of the reflection plate **144**, and a cover projection **144c** is formed at the second side of the reflection plate **144** for accommodating and covering the light source **143**.

The cover projection **144c** receives the light source **143** to cover an upper side of the light source **143** of an adjacent module when a plurality of the back-light unit modules are assembled, and may prevent the LED **143a** at the light input projection **142** of the light guide plate **141** from showing on a display screen.

As described before, the reflection plate **144** has a rim **147** substantially perpendicular to the light source **143**, which may be coupled to at least a portion of the third side **141c** and the fourth side **141d** of the light guide plate **141**, for at least partially preventing the light from transmitting to an adjacent light guide portion **140** from the light guide plate **141** through the third side **141c** and the fourth side **141d** of the light guide plate **141**.

Moreover, if a plurality of the light guide portions **130** or the back-light unit modules are assembled by making the

back-light units as modules, the modules can be coupled together as a side hook recess **144d** in the reflection plate **144** is placed on a side hook **148** (See FIG. **15**) of adjacent module, and the side hook **148** of the reflection plate **144** is placed in the side hook recess **144d** in adjacent module.

The side hook **148** and the side hook recess **144d** enable easy alignment and assembly of the plurality of modules in a first direction, for example, a transverse (or longitudinal, as seen from the other side) direction.

As a fastening member for fastening the frame (not shown) of the back-light unit, the reflection plate **144** has at least one underside hook **146** at an underside periphery for coupling to the frame (not shown).

The underside hook **146** enables easy fastening of the light guide plate module to the frame without screws.

FIG. **18** illustrates a plan view of a large sized back-light unit that is an assembly of a plurality of the back-light unit modules in FIG. **14**.

Thus, after fabricating the back-light units as a module, the side hook **148** of a first module **100D₁** is placed in the side hook recess **144d** of the second module adjacent thereto, to couple the first and second modules together.

Thus, by connecting other back-light unit modules to left and right sides of one back-light module, a plurality of modules can be fastened in a first direction (transverse direction; See FIG. **14**.) on a plane.

Referring to FIG. **19**, modules to be coupled in a second direction (a longitudinal direction; See FIG. **14**.) are coupled such that the cover projection **144c** of the reflection plate **144** of each of the modules covers the upper side of the LED **143a** of the back-light unit module adjacent thereto.

In this instance, at least some of boundaries between the modules (FIG. **19** illustrates a longitudinal direction boundary) may be made to couple a portion of the light optically. That is, portions of a light input part **142** side of the first module **100D₁**, and an edge side of the second module **100D₂** can be made to be at least partially shielded by the cover projection **144c** of the reflection plate **144**, optically.

That is, the cover projection **144c** of the reflection plate **144** is configured to reduce light from the corresponding module (the second module **100D₂**) passing into an adjacent module (the first module **100D₁**).

Therefore, a "B" portion of the boundary of the adjacent modules can be made to be coupled optically, and by adjusting a thickness of the cover projection **144c** or a shape of the edge side, an extent of the optical coupling of the modules can be adjusted. Accordingly, the "B" portion is a light transmitting part enabling optical coupling with the adjacent modules.

By adjusting or regulating the extent of the optical coupling, formation of a bright line of which light is stronger than the light from the light output surface **141e** of the light guide plate **141** or a relatively dark line of which light is weaker than the light from the light output surface **141e** of the light guide plate **141** can be at least partially prevented. According to this, in case the back-light unit is fabricated by connecting the plurality of modules side by side, a substantially uniform light can be formed by decreasing optical singular point at the light forwarding surface or an interconnected part between adjacent modules.

FIGS. **20** and **21** illustrate sections of coupling states of the light guide portions each having the light guide plate **141** and the reflection plate **144**, and a transverse direction coupling state of the modules coupled side by side.

As described before, though most of area of the underside **141f** of the light guide plate **141** couples to most of area of the upper side **144a** of the reflection plate **144**, the rim **147** of the reflection plate **144** couples to the third side **141c** and the

fourth side **141d** of the light guide plate **141**, when it can be made that a coupling projection **141g** of the light guide plate **141** is positioned over the upper side **147b** of the rim **147**.

That is, the rim **147** may have an inner side **147a**, an upper side **147b** and an outer side **147c**, wherein the inner side **147a** couples to the third side **141c** and the fourth side **141d**, and the upper side **147b** couples to the coupling projection **141g**. The outer side **147c** may be positioned to be in contact with the outer side **147c** of an adjacent module.

Thus, of the boundaries between modules, a portion of the transverse direction boundary can also be coupled optically. In other words, the other portion of the transverse direction boundary can also be shielded optically by the rim **147** of the reflection plate **144**.

Accordingly, a C portion of the boundary of the modules adjacent to each other can be made to be coupled optically, and by adjusting a height of the rim **147** or a thickness of the coupling projection **141g**, the extent of the optical coupling of the modules can be adjusted. Accordingly, the C portion is another light transmitting part enabling optical coupling with the adjacent modules.

Such an adjusted optical coupling at the C portion may also enable to suppress the formation of the relatively bright line or the dark line at the light output surface of the entire back-light unit.

The plurality of back-light unit modules coupled in the transverse and longitudinal directions thus are suitable for using as a back-light unit of a large sized display device.

Since the assembly of the plurality of back-light unit modules is made to be easy according to the described structure, a production cost may be reduced.

Moreover, the fabrication of the back-light unit by using the light guide plate may enable to reduce a thickness of the back-light unit, leading to reduction of a total thickness of the display device.

<A Fifth Embodiment>

Referring to FIGS. **22** to **27**, the back-light unit **100E** in accordance with a fifth embodiment of the present invention includes a light guide plate **151**, a light source **153**, a reflection plate **154** and at least one space retaining part **157**. The light guide plate **151** and the reflection plate **154** together may be called as a light guide portion **150** or a light guide plate module **150**. Unexplained parts may have things identical to the foregoing embodiments applied thereto.

The light guide plate **151** has a flat upper side, and sloped underside, and a light input part **152** is projected from a portion of a side.

The light guide plate **151** has opposite first side **151a** and a second side **151b**, and opposite third side **151c** and fourth side **151d**.

The light guide plate **151** has a thickness which becomes the thinner as the thickness goes from the first side **151a** to the second side **151b** the more, forming the underside of the light guide plate **151** to be sloped, may be entirely.

The light input part **152** at the first side **151a** of the light guide plate **151** may have a thickness thinner than a thickness of the first side **151a** of the light guide plate **151**.

According to this, an upper side of the light input part **152** and an upper side of the light guide plate **151** are positioned on planes different from each other.

Depending on cases, in order to transmit the light uniformly throughout the light guide plate **151**, a portion of a lower side of the light input part **152** may be formed unevenly.

An upper side of the circuit board **153b** of the light source **153** coupled to the underside of the light input part **152** may also be formed unevenly at the same position.

The light guide plate **151** may have at least one fastening protrusion **155** protruding from an underside periphery as a fastening member for coupling to the upper side of the reflection plate **154**, additionally.

The fastening protrusion **155** is placed in a fastening recess **154a** in the upper side of the reflection plate **154** for retaining a position even against an external impact or vibration.

The light guide plate **151** has at least one space retaining part **157** on an upper side.

The space retaining part **157** is at least one protrusion, for supporting an optical sheet **250** shown in FIG. **27** to retain a gap of an air layer between the light guide plate **151** and the optical sheet **250**.

Of the surfaces of the protrusion **157**, a surface in contact with the light guide plate **151** is flat, and a surface in contact with a surface of the optical sheet **250** may be formed to be semi-circular to have a curvature.

It is beneficial that a radius of the curvature of the protrusion **157** in contact with the surface of the optical sheet **250** is about 0.1~1 mm.

This is because a loss of the light due to reflection or refraction at the protrusion **157** may become larger if the radius of the curvature is below about 0.1 mm or over about 1 mm.

Therefore, it is beneficial to fabricate the protrusion **157** by adjusting the curvature of the protrusion **157** appropriately such that the light incident onto the protrusion **157** is not lost, but proceeds in a direction of the optical sheet **250** as much as possible.

Moreover, it is beneficial that the protrusion **157** has a height "h" of about 1~2 mm, one of which reason is that, if the height "h" of the protrusion **157** is below about 1 mm, the gap of the air layer is too small for an incident light to diffuse, making effectiveness of the air layer gap poor, and if the height "h" of the protrusion **157** is over about 2 mm, a total thickness of the back-light unit **100E** becomes thick, making effectiveness of the back-light unit poor.

It is beneficial that a distance "d" between adjacent protrusion **157** is about 1/3 of a distance from a light input surface (the light input part **152**) to a light output surface (a light forwarding surface) of the light guide plate **151**.

That is, it is beneficial that the distance "d" between adjacent protrusion **157** is about 2~3 cm. This is because, if the distance "d" between adjacent protrusion **157** is below about 2 mm, a number of the protrusion **157** formed on the surface of the light guide plate **151** increases, causing a light loss coming from reflection and refraction of the incident light, and if the distance "d" between adjacent protrusions **157** is over about 3 mm, the optical sheet **250** supported by the protrusion **157** can overhang or sag, causing improper diffusion of the light.

Therefore, it is beneficial that adjacent projections **157** are symmetric in left/right directions with respect to the surface of the light guide plate **151**, and formed at an appropriate distance and number.

Depending on cases, it is beneficial that the protrusion **157** is formed of a material that is transparent and has a low surface tension so that the protrusion **157** can be adhered to the light guide plate **151**, easily.

For an example, the protrusion **157** may be formed of PMMA (Polymethylmethacrylate), polycarbonate, cyclic olefin copolymer, and so on, or, depending on cases, the same material with the light guide plate **151**.

In the meantime, the light source **153** is at a side of the light input part **152** for emitting the light to the light guide plate **151**, and may include at least one LED **152a** and a circuit board **153b**.

The LED **153a**, at the side of the light input part **152**, generates and emits the light to the light input part **152**.

The circuit board **153b** supports and couples to undersides of the LED **153a** and the light input part **152**.

The light input part **152** is projected from the side of the light guide plate **151** for decreasing relatively dark portions between the LEDs **153a**, and at least partially preventing the light from the LED **153a** from leaking directly through interconnected portions between the back-light units.

The reflection plate **154** couples to an underside of the light guide plate **151** for reflecting the light to the light guide plate **151**, and covers the second to fourth sides **151b**, **151c** and **151d** of the light guide plate **151** for adjusting transmission of the light from the light guide plate **151** to an outside of the back-light unit or adjacent modules.

An upper side of the reflection plate **154** has a slope opposite to the slope of the underside of the light guide plate **151**.

Accordingly, if the reflection plate **154** is placed on the light guide plate **151** such that the upper side of the reflection plate **154** couples to the underside of the light guide plate **151**, the underside of the reflection plate **154** and the upper side of the light guide plate **151** are parallel to each other.

That is, the reflection plate **154** has opposite first and second sides, and has a thickness which becomes the thicker as the thickness goes from the first side to the second side the more.

The light source **153** is positioned at the first side of the reflection plate **154**, and a cover projection **154b** is formed at the second side of the reflection plate **154**.

The cover projection **154b** covers an upper side of the light source of an adjacent back-light unit when a plurality of the back-light units are assembled, and may prevent the LED **153a** at the light input part **152** of the light guide portion **151** from showing on a display screen.

As a fastening member for coupling to the light guide plate **151**, the reflection plate **154** may have at least one fastening recess **154a** at an upper side periphery.

As described, the fastening protrusion **155** of the light guide plate **151** is placed in the fastening recess **154a** in the reflection plate **154** for maintaining a position even against an external impact or vibration.

Moreover, the reflection plate **154** has opposite third side and fourth side, wherein the third side has a side hook recess **154c** as a fastening member for coupling to the back-light unit adjacent thereto at the time a plurality of the back-light units are assembled, and the fourth side has a side hook **158** as a member for coupling to the back-light unit adjacent thereto.

If the back-light units are fabricated as modules and a plurality of the back-light units assembled, the back-light units can be coupled together as the side hook recess **154c** in the reflection plate **154** is placed on the side hook of the back-light unit adjacent thereto, and the side hook **158** of the reflection plate **154** is placed in the side hook recess in the back-light unit adjacent thereto.

The side hook **158** and the side hook recess **154c** enable easy alignment and assembly of the plurality of the back-light units in a transverse (or longitudinal, as seen from the other side) direction.

As a fastening member for fastening the back cover (not shown) of the back-light unit, the reflection plate **154** has at least one underside hook **156** at an underside periphery for coupling to the back cover (or a frame; not shown).

The underside hook **156** enables easy fastening of the reflection plate **154** to the back cover of the back-light unit without screws like the related art.

FIG. 26 illustrates a large sized back-light unit having a plurality of the back-light units in FIG. 22 fabricated into modules and assembled together.

Referring to FIG. 26, after fabricating the light guide portion 150 having the light guide plate 151 and the reflection plate 154 under the light guide plate 151 as a module, the side hook 158 of one module may be placed in the side hook recess 154c in the other back-light unit adjacent thereto to couple the one module to the other back-light unit.

By connecting the back-light units on opposite side of the back-light unit, a plurality of the back-light units can be aligned in a transverse direction.

Referring to FIG. 27, in the back-light units arranged in a longitudinal direction, the cover projection 154b of the reflection plate 154 of the back-light unit covers an upper side of the LED 153a of the back-light unit adjacent thereto, for at least partially preventing the LED 153a at the light input part 152 of the light guide plate 151 from showing on a display screen.

Since the back-light unit has an underside hook 156, for fastening to the back cover (not shown) of the back-light unit.

The protrusion 157 on the upper side of the light guide plate 151 supports the optical sheet 250, for retaining a gap of the air layer between the light guide plate 151 and the optical sheet 250.

The air layer diffuses the light from the light guide plate 151 like a related art diffusion plate owing to a difference of refractive indices.

The light diffused at the air layer incidents on the display panel such that the light is distributed throughout display panel uniformly as the light pass through the optical sheet 250, enabling the display panel to obtain a relatively uniform brightness.

As an example, the optical sheet 250 has the diffusion sheet 250a, a prism sheet 250b, and a protective sheet 250c stacked in succession, wherein the diffusion sheet 250a scatters the light from the light guide plate 151 to make a brightness distribution of the light uniform, the prism sheet 250b converges the light to the display panel, and the protective sheet 250c protects the prism sheet 250b.

Thus by forming the gap of the air layer between the light guide plate and optical sheet with the projection of the light guide plate, an optical unevenness taking place at a boundary of adjacent light guide plates can be reduced.

<A Sixth Embodiment>

Referring to FIGS. 28 and 29, the back-light unit 100F in accordance with a sixth embodiment of the present invention includes a light guide plate 161, a light source 163, a reflection plate 164 and a frame 165. Things applied to the foregoing embodiments can be applied to part unexplained herein. The light guide plate 161 and the reflection plate together may be called as a light guide portion or a light guide module 160.

The light guide plate 161 has a flat upper side, a sloped underside, and a light input part 162 at a portion of a side for receiving a light from the light source 163.

The light guide plate 161 has a thickness which becomes the thinner as the thickness goes the farther from the light input part 162, making the underside of the light guide plate 161 sloped on the whole.

The light source 163 includes a circuit board 163b having the LED 163a mounted thereon.

The light input part 162 of the light guide plate 161 may have a thickness thinner than the light guide plate 161 and projected from the light guide plate 161. That is, since the light input part 162 is projected from an effective screen, the light input part 162 can decrease a relatively dark portion caused by a gap between the light sources 163, and prevent

the light from leaking direct from the light source 163 through a connection portion between the light guide plates 161.

The reflection plate 164 is coupled to an underside of the light guide plate 161, for an example, by means of a fastening protrusion 161a of the light guide plate 161 to a fastening hole 164b in the reflection plate 164.

In this instance, the reflection plate 164 may have a rim 164a at least a side for the light guide plate 161 to couple to the reflection plate 164, securely.

Referring to FIGS. 28 and 29, the rim 164a is shown angled upward from opposite edges of the reflection plate 164 and extended therefrom, with the light guide plate 161 disposed therebetween.

At least one fastening hole 164b may be formed in the rim 164a, enabling the fastening protrusion 161a on the light guide plate 161 to be fastened to the fastening hole 164b more securely.

The light guide plate 161 may have projection 161b along opposite edges of the light guide plate 161 in contact with edges of the rim 164a for positioning the light guide plate 161 with respect to the reflection plate 164.

Since the projection 161b is positioned over the edge of the rim 164a and connected to the projection 161b on an adjacent light guide plate 161, the rim 164a can prevent the light from being discontinued and adjust an extent of light coupling to an adjacent light guide portion 160.

In a case the back-light units 100F in accordance with the sixth embodiment of the present invention having the light guide plate 161 and the reflection plate 164 are connected side by side, it can be made that the rim 164a is invisible if seen from a light output side.

The rim 164a may also include a function of the reflection plate 164, to cover at least a portion (a portion excluding the projection 161b) of a side of the light guide plate 161, such that, when the back-light units in accordance with the sixth embodiment of the present invention adjacent to each other are coupled together as modules, the transmission of the light to an adjacent back-light unit is adjusted, enabling to adjust a relatively bright line or a dark line formed at a boundary of the modules.

Since the light input part 162 and the edge opposite thereto of the light guide plate 161 are not covered with the rim 164a, possible formation of relatively bright/dark line at the boundary of the light guide plates 161 and relatively dark portion at the light input part 162 caused by the step of the light input part 162 can be reduced, thereby improving uniformity of the light from a plurality of the light guide plates 161 significantly.

In the meantime, by providing a connection part 161c at the other edge of the light input part 162 of the light guide plate 161 for fastening to the reflection plate 164 additionally, the light guide plate 161 can be coupled to the reflection plate 164 more rigidly.

When the light guide plate 161 is coupled to the reflection plate 164 together, the edge 164c of the reflection plate 164 on an opposite side of the light input part 162 has a step such that the edge 164c is positioned over adjacent light input part 162, for an example, as shown in FIG. 29.

If the edge 164c of the reflection plate 164 is positioned over the adjacent light input part 162 thus, direct emission of the light from the LED 163a at the light source 163 to an outside of the back-light unit can be prevented.

That is, by placing the LED 163a at a side of the light guide plate 161 and the reflection plate 164 formed in a small size, an adequate light quantity can be secured, heat from the LED

163a can be dispersed, and, especially, the LED **163a** at the side of the light guide plate **161** and the reflection plate **164** can be hidden, optically.

Referring to FIG. **30**, since a large sized back-light unit can be fabricated by coupling the light guide plate **161** and the reflection plate **164** adjacent to each other, it is beneficial to maintain a relative position of the light guide plate **161** and the reflection plate **164** constant.

That is, when a plurality of the back-light units **100F** each having the light guide plate **161** and the reflection plate **164** in accordance with the sixth embodiment of the present invention are coupled together, size variation of the light guide plate **161** and the reflection plate **164** of the back-light unit can be kept small.

Thus, when the plurality of the back-light units **100F** in accordance with the sixth embodiment of the present invention are coupled together to form the large sized back-light unit, the back-light unit **100F** includes a light guide portion connection part **167** for coupling the light guide portion **160** having the light guide plate **161** and the reflection plate **164** to a frame **165**.

The light guide portion connection part **167** is fastened to a frame connection part **166** at the frame **165**.

In this instance, referring to FIGS. **31** to **33**, the light guide portion connection part **167** can be slidably fastened to the frame connection part **166**.

That is, the light guide portion connection part **167** has a projection **167a**, and the frame connection part **166** has a sliding slot **166a** for placing the projection **167a** therein and sliding the projection **167a** thereon until the projection is fastened.

Referring to FIG. **32**, the sliding slot **166a** has a first slot **166a₁**, for placing the projection **167a** therein, and a second slot **166a₂** extended from and narrower than the first slot **166a₁**.

Accordingly, by fastening the light guide portion connection part **167** to the frame connection part **166**, the light guide plate **161** and the reflection plate **164** can be coupled to the frame **165**, easily.

That is, without additional screw fastening, the light guide plate **161** and the reflection plate **164** can be coupled to the frame **165**, a fastening direction (an arrow direction in FIG. **32**) of the slidable fastening can be in any direction of upper/lower, left/right directions.

Moreover, referring to FIG. **33**, the light guide portion connection part **167** may have a supplementary (or auxiliary) protrusion **167b** additionally and the frame connection part **166** may have an inserting hole (opening) **166b** additionally for inserting the supplementary protrusion **167b** therein.

By making the supplementary protrusion **167b** and the inserting hole **166b** to be fastened together at a position the protrusion **167a** and the sliding slot **166a** are fastened together, after the light guide plate **161** and the reflection plate **164** are slidably coupled to the frame **165**, the coupling state can be kept rigidly.

In the meantime, as shown, it may be beneficial that the light guide portion connection part **167** is positioned at the reflection plate **164**.

Thus, the light guide plate **161** and the reflection plate **164** coupled adjacent to each other can be coupled in a transverse direction or a longitudinal direction, and by connecting the light guide plate **161** and the reflection plate **164** and the light source **163**, a back-light unit for a large sized display device can be fabricated.

Moreover, by connecting the light guide plate **161** and the reflection plate **164** in a tiling fashion, reliability of the large sized back-light unit can be improved, and local dimming in

which the light source **163** is driven partially according to an image can be applicable, enabling to produce an image of a high contrast ratio.

<A Seventh Embodiment>

Referring to FIGS. **34** and **35**, a liquid crystal display device **400** can be fabricated by using the back-light unit in accordance with one of the first to sixth embodiment of the present invention (reference numerals **100A** to **100F**, hereinafter represented with a reference numeral **100**) described before and the liquid crystal display panel **200**.

Referring to FIG. **35**, the liquid crystal display panel **200** on the back-light unit **100** of the present invention includes an upper substrate **200a**, a lower substrate **200b** and a liquid crystal layer **200c** injected between the upper substrate **200a** and the lower substrate **200b**.

On one side of the liquid crystal display panel **200**, there is a driver (not shown) for driving the liquid crystal display panel.

Referring to FIG. **34**, there are a lower cover **260** which covers the back-light unit **100** under the back-light unit **100**, and an upper cover **270** which covers a front of the liquid crystal display panel **200** on the liquid crystal display panel **200**.

The liquid crystal display panel **200** includes a matrix of liquid crystal cells, for forming an image by controlling light transmission ratios of the liquid crystal cells according to information on an image signal from the driver.

The driver may include a flexible printed circuit board FPC, a driver chip mounted to the FPC, and a printed circuit board PCB connected to the other side of the FPC.

In the meantime, referring to FIG. **35**, the back-light unit **100** may be position in rear of the liquid crystal display panel **200**, and a plurality of optical sheets **250** may be provided on the back-light unit **100**.

The optical sheets (Also, refer to FIG. **27**.) are on a back side of the liquid crystal display panel **200**, and may include a diffusion sheet **250a**, a prism sheet **250b**, and a protective sheet **250c**.

The diffusion sheet **250a** diffuses the light from the back-light unit **100** and supplies the light to the liquid crystal display panel **200**.

The prism sheet **250b** has an array of triangular prisms on an upper side, for covering the light diffused at the diffusion sheet in a direction perpendicular to a plane of the liquid crystal display panel **200** position over the prism sheet **250b**.

The micro-prism on the prism sheet **250b** has a predefined angle. Most of the light passed through the prism sheet **250b** proceeds perpendicular to the prism sheet **250b** to provide a uniform luminance distribution.

The protective sheet **250c** at the uppermost side protects the prism sheet **250b** which is susceptible to scratch.

Referring to FIG. **35**, formed on the lower substrate **200a** of the liquid crystal display panel **200**, there are a matrix of gate lines and data lines, and a pixel electrode and a thin film transistor TFT **200d** at every cross point of the gate lines and the data lines.

A signal voltage applied to the liquid crystal display panel **200** through the thin film transistor **200d** is supplied to the liquid crystal layer **200c** by the pixel electrode, and the liquid crystal layer **200c** is aligned according to the signal voltage to fix a light transmission ratio.

Formed on the upper substrate **200b**, there are a color filter **200g** having R, G, B pixels for producing a predefined color as the light passes therethrough, and a common electrode **200f** of a transparent conductive material, such as ITO (Indium Tin Oxide) or IZO (Indium Zinc Oxide).

Alignment films may be positioned on upper/lower sides of the liquid crystal layer **200c**.

The liquid crystal display device can maximize a performance by using the back-light unit in accordance with one of the first to sixth embodiments of the present invention.

<An Eighth Embodiment>

FIG. **36** illustrates a block diagram of a liquid crystal TV set having a liquid crystal display device in accordance with an eighth embodiment of the present invention applied thereto.

The liquid crystal TV set has a system as shown in FIG. **36**, for transmission and display of a broadcasting data stream from a tuner **510** to the liquid crystal display device **400** through a processor **520**, a decoder **530**, and an A/V output unit **540**.

The tuner **510** or the processor **520** is controlled by a control unit **550**, and the controller **550** may include a memory **560** additionally.

If a user selects and set a broadcasting channel by operating the liquid crystal TV set **500**, the controller **550** controls the tuner **510** and the processor **520**, to select a broadcasting channel the user set thus, and the processor **520** splits the data stream of a broadcasting program provided through the broadcasting channel into an audio and video data, and forwards the audio and video data split thus.

Then, the decoder **530** decodes the data the processor **520** into audio and video signals, for forwarding the audio and video signals to the liquid crystal display device **400** or an audio output unit **570** such as a speaker unit through the A/V output unit **540**.

In this instance, the back-light unit **100** is driven by a back-light unit controller **410**, for illuminating an image forwarded to the liquid crystal display panel **200**.

In the meantime, the processor **520** may receive the broadcasting data stream through the Internet.

Thus, the back-light unit **100**, the liquid crystal display device **400** with the back-light unit **100** and the liquid crystal TV set **500** with the liquid crystal display device **400** of the present invention have been described in detail.

In the back-light unit **100** of the present invention, an upper side width of the light input part is formed smaller than a lower side width of the light input part, shifting a light path of the light reflected totally, to increase a light quantity of the light forwarded upward from the light guide plate.

The arrangement of the LEDs at a side of the light guide plate permits to reduce a total thickness of the back-light unit, thereby enabling to reduce a display panel, such as the LCD.

Fabricating the back-light unit having the light guide plate and the LEDs coupled thereto as a module, and assembling a plurality of the modules by connecting the modules in a tiling fashion permits to provide a back-light unit suitable for a large sized display device.

The fastening hook and fastening member on the reflection plate of the back-light unit fabricated as the module permits easy and simple assembly, not only with an adjacent back-light unit, but also with a back cover of the back-light unit.

The projection on the light guide plate to form an air layer gap between the light guide plate and the optical sheet reduces an optical unevenness taking place at a boundary of adjacent light guide plates.

The formation of fastening members at the light guide plate modules permits easy and simple assembly with an adjacent module, as well as with the frame.

The applicability of the local dimming in which the light source is driven partially according to an image permits to produce an image of a high contrast ratio.

A portion of the boundary of the adjacent modules can be made to be coupled optically, and an extent of the optical coupling of the modules can be adjusted. By adjusting or regulating the extent of the optical coupling, a relatively bright line or a dark line on light forwarding surface or on an interconnected part between adjacent modules can be prevented or reduced.

According to this, in case the back-light unit is fabricated by connecting the plurality of modules side by side, a substantially uniform light can be formed by decreasing optical singular point at the interconnected part.

It will be apparent to those skilled in the art that various modifications and variations can be made in the present invention without departing from the spirit or scope of the inventions. Thus, it is intended that the present invention covers the modifications and variations of this invention provided they come within the scope of the appended claims and their equivalents.

What is claimed is:

1. A backlight comprising:
 - a circuit board;
 - a plurality of light emitting diode (LED) sources arranged on the circuit board, the LED source having a top surface and a bottom surface that are opposite surfaces and side surfaces between the top surface and the bottom surface, and light is emitted from at least one of the side surfaces; and
 - a plurality of light guide plates, the light guide plate including an input part to receive light emitted from the LED source, an opposite edge, and a side part, wherein the light guide plates have a thickness changing part that changes in thickness based on distance from the corresponding input part,
 wherein the opposite edge of the light guide plate is arranged such that the opposite edge covers the input part of another one of the light guide plates and the LED sources provided on the circuit board, and
 - wherein the light guide plates are optically coupled by the opposite edge and the side part, and wherein the side part is partially optically shielded from the adjacent side part and is optically coupled to the adjacent side part.
2. The backlight of claim 1, wherein the thickness changing part is a thickness decreasing part that decreases in thickness based on distance from the corresponding input part.
3. The backlight of claim 1, wherein the LED sources are directly mounted on the circuit board.
4. The backlight of claim 1, further comprising:
 - a reflection plate arranged on a backside of the light guide plate.
5. The backlight of claim 1, wherein sizes and appearances of the light guide plates are substantially the same on each of the light guide plates.
6. The backlight of claim 1, wherein the plurality of the light guide plates are arranged in a tiled manner.
7. The backlight of claim 1, wherein the light guide plate comprises a first side wall connected to the input part and a second side wall facing the first side wall, and an end of the circuit board corresponds to the first side wall.
8. The backlight of claim 1, wherein the plurality of the light guide plates include a first light guide plate and a second light guide plate adjacent to the first light guide plate, and the LED sources are provided in a recess portion formed by the first light plate and the second light guide plate.
9. A liquid crystal display (LCD) comprising:
 - a LCD panel;
 - a backlight unit provided on one side of the LCD panel, wherein the backlight unit comprises:

a circuit board,
 a plurality of light emitting diode (LED) light sources arranged on the circuit board, and
 a plurality of light guide plates including an input part to receive light emitted from the LED light source, an opposite edge to face the input part, and a side part, wherein the plurality of light guide plates are optically coupled by the opposite edge and the side part;
 a reflection plate on one side of the light guide plate, the reflection plate having a rim, wherein the rim partially optically shields a portion of at least one of the opposite edge or the side part; and
 a frame on one side of the reflection plate such that the reflection plate is between the light guide plate and the frame, the frame having a plurality of holes formed therein,
 wherein the opposite edge of the light guide plate is arranged such that the opposite edge of the light guide plate overlaps at least a portion of the input part of another one of the light guide plates.

10. The LCD of claim 9, wherein the LED light source has a top surface and a bottom surface that are opposite surfaces and side surfaces between the top surface and the bottom surface, and light is emitted from at least one of the side surfaces.

11. The LCD of claim 9, further comprising:
 a front cover to cover a front surface of the LCD panel; and
 a rear cover to cover a rear surface of the backlight unit.

12. The LCD of claim 9, wherein each of the light guide plates has a thickness changing part that changes in thickness based on distance from the corresponding input part.

13. The LCD of claim 12, wherein the thickness changing part is a thickness decreasing part that decreases in thickness from the input part to the opposite edge.

14. A backlight comprising:
 a first module including a first circuit board, a plurality of light emitting diode (LED) light sources arranged on the first circuit board and a first light guide plate having an input part to receive light emitted from the LED light source, an opposite edge, and a side part, and a first reflection member arranged over a rear surface of the first light guide plate, wherein the first reflection member comprises a first rim; and
 a second module including a second circuit board, a plurality of LED light sources arranged on the second circuit board and a second light guide plate having an input part to receive light emitted from the LED light source, an opposite edge, and a side part, and a second reflection member arranged over a rear surface of the second light guide plate, wherein the second reflection member comprises a second rim;

wherein the first module is adjacent to the second module, wherein the LED light source of the first module is provided between the first circuit board and the second reflection member, wherein the second reflection member is provided between the LED light source of the first module and the opposite edge of the second light guide plate, wherein the first light guide plate and the second light guide plate are optically coupled by the opposite edge and the side part that are facing each other, and wherein at least one of the first rim or the second rim partially optically shields a portion between the first light guide plate and the second light guide plate.

15. The backlight of claim 14, wherein at least one of the first light guide plate and the second light guide plate has a thickness changing part that changes in thickness based on distance from the corresponding input part.

16. The backlight of claim 15, wherein the thickness changing part is a thickness decreasing part that decreases in thickness based on distance from the corresponding input part.

17. The backlight of claim 14, wherein the LED light source of the first module has a top surface and a bottom surface that are opposite surfaces and side surfaces between the top surface and the bottom surface, and light is emitted from at least one of the side surfaces.

18. The backlight of claim 14, wherein a gap is provided between the second reflection member and the LED light source of the first module.

19. The backlight of claim 14, wherein the LED light source of the first module is provided to a side of the first circuit board.

20. The backlight of claim 14, wherein the LED light source of the first module directly contacts the first light guide plate.

21. The backlight of claim 1, wherein the portion of the side part is optically shielded such that optical coupling of an adjacent light guide plate can be adjusted.

22. The backlight of claim 1, wherein the reflection plate comprises a rim.

23. The backlight of claim 22, wherein the portion of the side part is optically shielded by the rim.

24. The backlight of claim 14, wherein the portion includes a portion between the input part of the first light guide plate and the opposite edge of the second light guide plate.

25. The backlight of claim 14, wherein the portion includes a portion between the side part of the first light guide plate and the side part of the second light guide plate.

* * * * *

| | | | |
|----------------|--|---------|------------|
| 专利名称(译) | LED背光单元和使用该单元的液晶显示装置 | | |
| 公开(公告)号 | US8189135 | 公开(公告)日 | 2012-05-29 |
| 申请号 | US12/453885 | 申请日 | 2009-05-26 |
| [标]申请(专利权)人(译) | BAE SEUNG CHOON 金胜SE HUR勋 | | |
| 申请(专利权)人(译) | BAE SEUNG CHOON 金胜SE HUR勋 | | |
| 当前申请(专利权)人(译) | LG电子株式会社. | | |
| [标]发明人 | BAE SEUNG CHOON KIM SEUNG SE HUR HOON | | |
| 发明人 | BAE, SEUNG CHOON KIM, SEUNG SE HUR, HOON | | |
| IPC分类号 | G02F1/1335 G02F1/1333 F21V7/04 | | |
| CPC分类号 | G02B6/008 G02F1/133615 G02B6/0031 G02B6/0046 G02B6/0055 G02B6/0088 G02F1/133605 | | |
| 优先权 | 1020080049146 2008-05-27 KR 1020080061487 2008-06-27 KR 1020080099569 2008-10-10 KR 1020090035029 2009-04-22 KR | | |
| 其他公开文献 | US20090296026A1 | | |
| 外部链接 | Espacenet USPTO | | |

摘要(译)

讨论了LED背光单元和使用LED背光单元的其他装置。根据一个实施例，一种LED背光单元，包括导光部分，所述导光部分包括导光板和耦合到所述导光板的反射板，其中所述导光板具有光输入部分和第一连接部分，以及其中，反射板具有连接到第一连接部分的第二连接部分，以及包括至少一个发光二极管的光源，光源朝向光导部分发光。

