



US007515229B2

(12) **United States Patent**  
**Chang**

(10) **Patent No.:** **US 7,515,229 B2**  
(45) **Date of Patent:** **Apr. 7, 2009**

(54) **DIRECT TYPE BACKLIGHT MODULE AND LIQUID CRYSTAL DISPLAY USING SAME**

2005/0088593	A1*	4/2005	Yamauchi	349/114
2005/0201077	A1*	9/2005	Tsai	362/26
2007/0047228	A1*	3/2007	Thompson et al.	362/237
2007/0133097	A1*	6/2007	Lubart et al.	359/641

(75) Inventor: **Jen-Tsorng Chang**, Tu-Cheng (TW)

(73) Assignee: **Hon Hai Precision Industry Co., Ltd.**, Tu-Cheng, Taipei Hsien (TW)

(\* ) Notice: Subject to any disclaimer, the term of this patent is extended or adjusted under 35 U.S.C. 154(b) by 232 days.

FOREIGN PATENT DOCUMENTS

CN	2604706	Y	2/2004
JP	2002-298629	A	10/2002

(21) Appl. No.: **11/478,413**

(22) Filed: **Jun. 28, 2006**

(65) **Prior Publication Data**

US 2007/0030414 A1 Feb. 8, 2007

(30) **Foreign Application Priority Data**

Aug. 5, 2005 (CN) ..... 2005 1 0036429

(51) **Int. Cl.**  
**G02F 1/1335** (2006.01)  
**F21V 7/04** (2006.01)

(52) **U.S. Cl.** ..... **349/114; 362/606**

(58) **Field of Classification Search** ..... None  
See application file for complete search history.

(56) **References Cited**

U.S. PATENT DOCUMENTS

6,561,663	B2*	5/2003	Adachi et al.	362/616
6,867,829	B2	3/2005	Chiou	

\* cited by examiner

*Primary Examiner*—Michelle R. Connelly-Cushwa

*Assistant Examiner*—Chris Chu

(74) *Attorney, Agent, or Firm*—Andrew C. Cheng

(57) **ABSTRACT**

A direct type backlight module (1) includes at least one light source (11) for emitting light beams, and a light guide plate (12) having a first surface (13), an opposite second surface (14), and at least one transmissive unit (16) arranged on the first surface adjacent to the corresponding at least one light source. The at least one transmissive unit is configured for reflecting a first part of the incident light beams, and allowing a second part of the incident light beams to pass therethrough. The present backlight module has a high level of brightness uniformity.

**20 Claims, 9 Drawing Sheets**

1

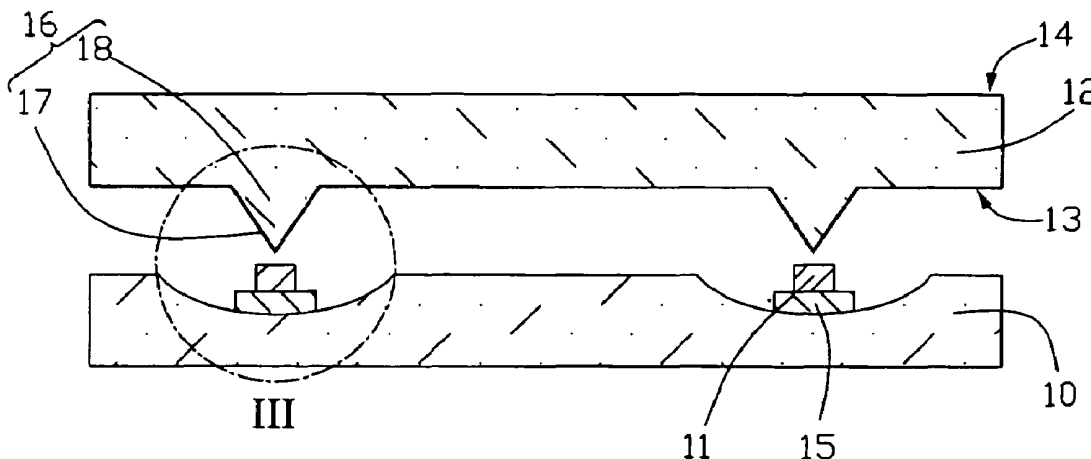

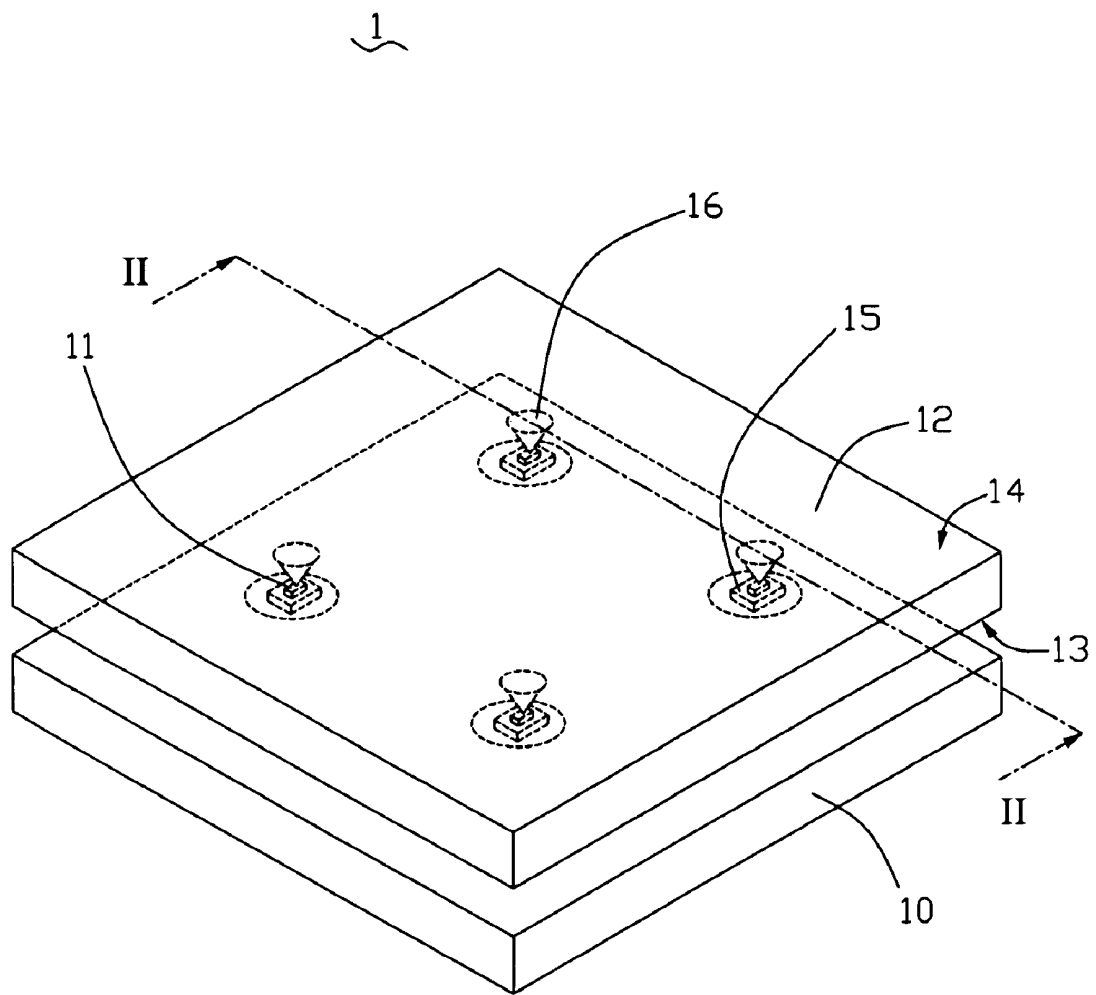

FIG. 1

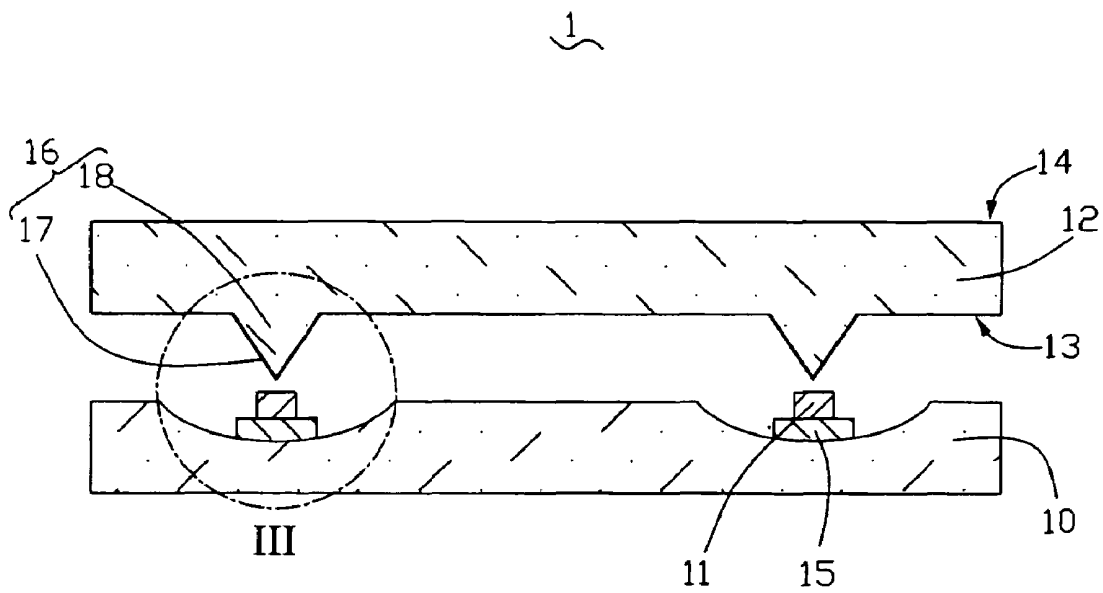

FIG. 2

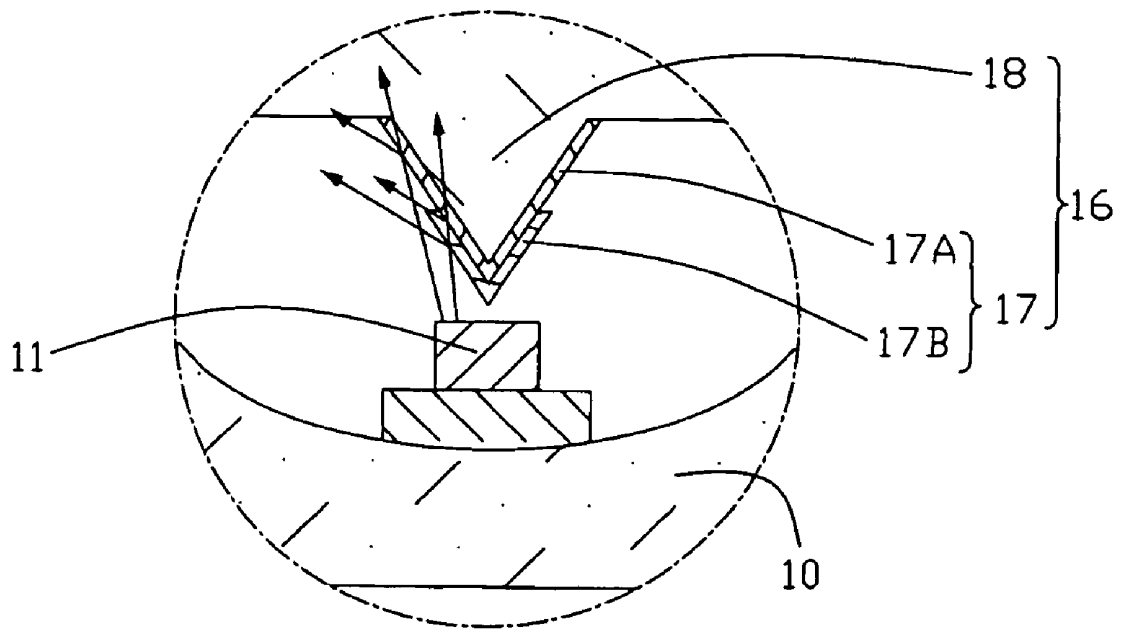
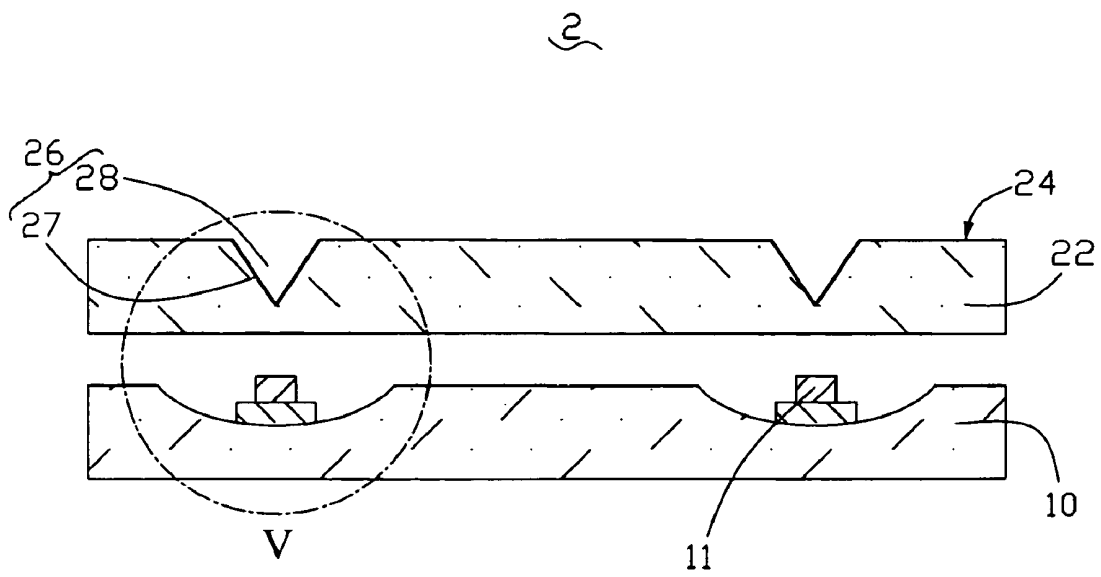

FIG. 3



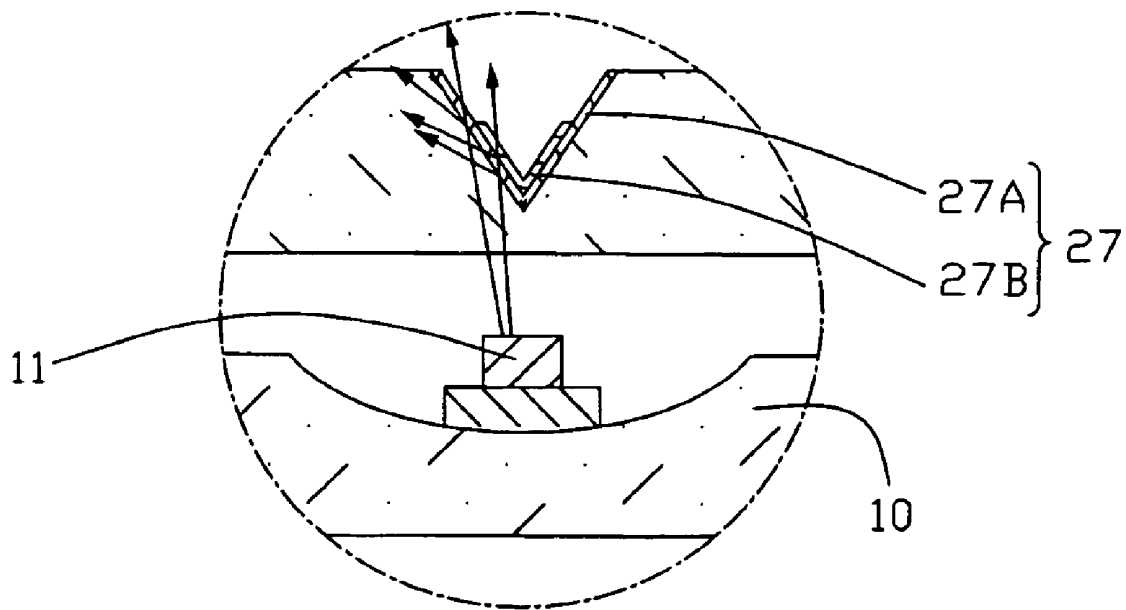

FIG. 5

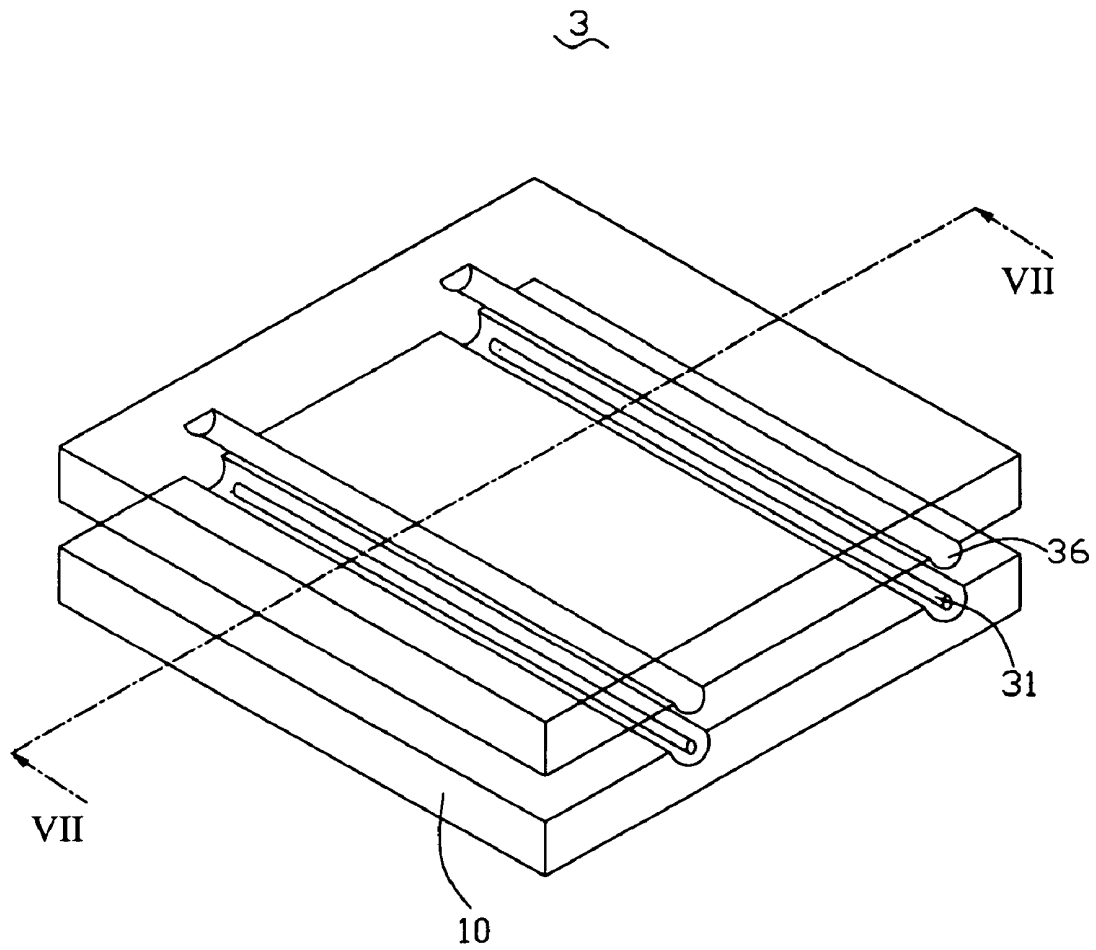

FIG. 6

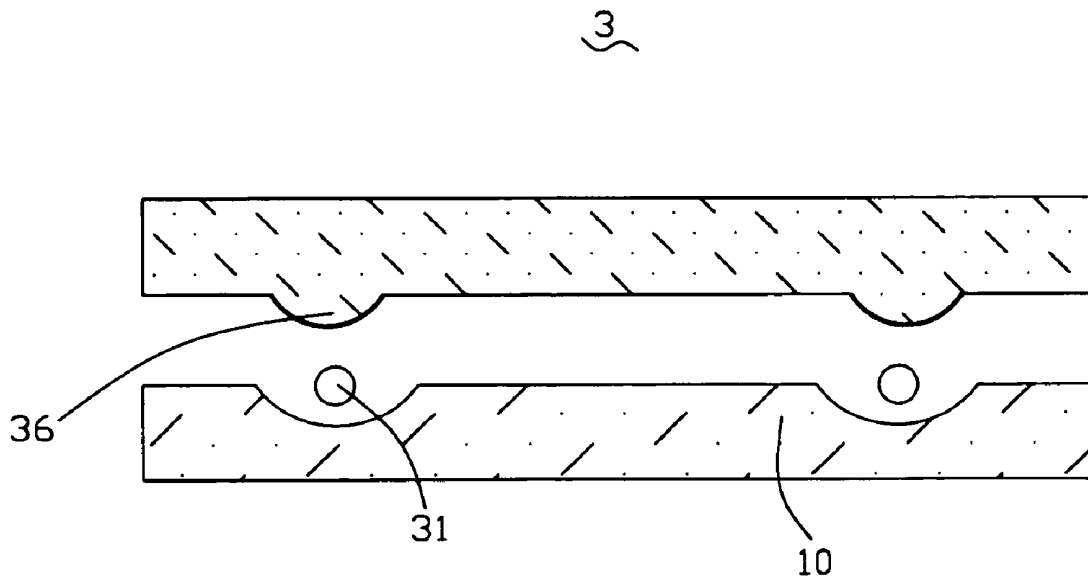

FIG. 7

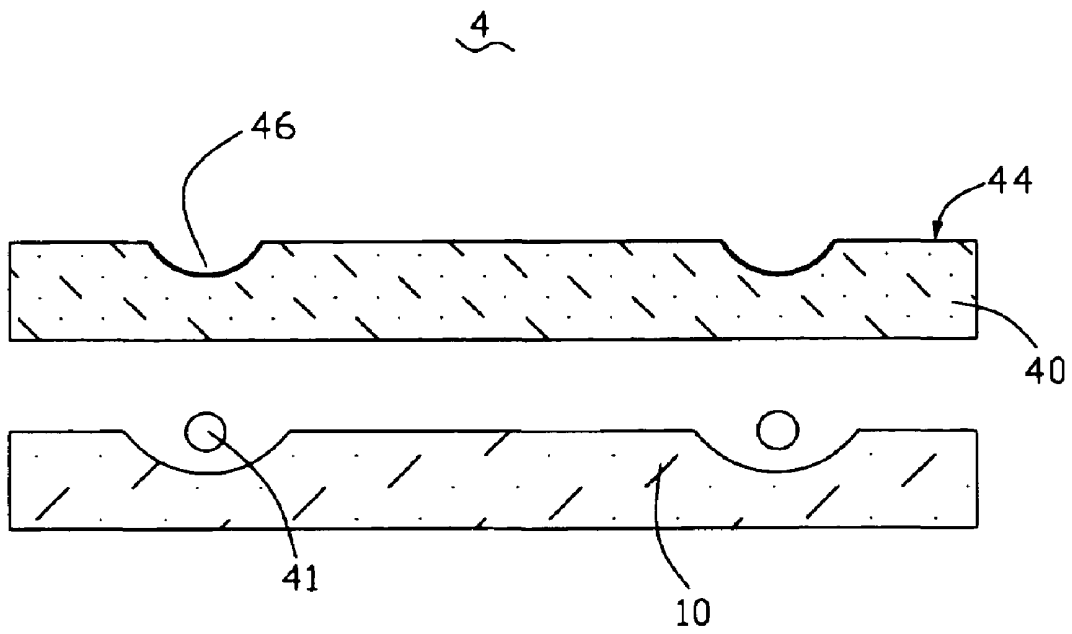

FIG. 8

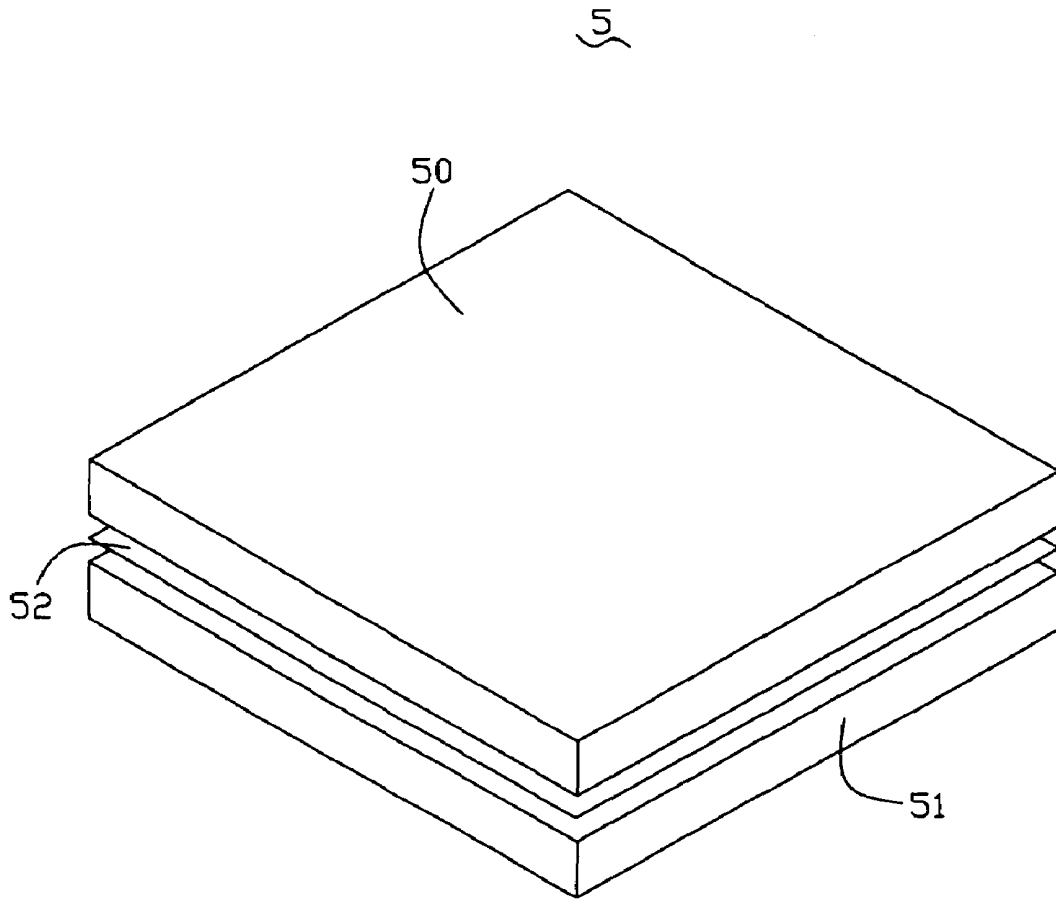

FIG. 9

# DIRECT TYPE BACKLIGHT MODULE AND LIQUID CRYSTAL DISPLAY USING SAME

## TECHNICAL FIELD

The present invention relates to a backlight module and, more particularly, to a direct type backlight module and a liquid crystal display having the same.

## BACKGROUND

Nowadays, liquid crystal materials are widely utilized in various liquid crystal displays having different sizes for different applications, such as TVs, liquid crystal projectors, mobile telephones, personal digital assistants (PDA), etc. Because liquid crystal itself cannot emit light, light sources must be utilized to illuminate liquid crystal for image display. The light sources are called backlight sources since they are usually configured behind liquid crystal panels. A combination of all components behind the liquid crystal panels, including the light sources, is generally referred to as a backlight module. Usually, the backlight modules can be classified into edge type backlight modules and direct type backlight modules.

A typical direct type backlight device includes a light guide plate and a plurality of light sources arranged behind the light guide plate. Because the plurality of light sources are arranged behind the light guide plate, the regions of the light guide plate adjacent to the light sources are brighter than those further away from the light sources. Thus brightness uniformity of the direct type backlight device is impaired. One method for solving this problem includes adding an amount of light sources, but this will produce new problems, such as high cost and over-heating. It cannot satisfy needs of the high quality of direct type backlight devices and liquid crystal displays.

What is needed, therefore, is a direct type backlight module with high brightness uniformity and a corresponding liquid crystal display.

## SUMMARY

A direct type backlight module according to one preferred embodiment includes at least one light source for emitting light beams, and a light guide plate having a first surface, an opposite second surface and at least one transmissive unit arranged on the first surface adjacent to the corresponding at least one light source. The at least one transmissive unit is configured for reflecting a first part of the incident light beams, and allowing a second part of the incident light beams to pass therethrough.

A liquid crystal display according to another preferred embodiment includes a liquid crystal display panel, and a direct type backlight module arranged adjacent to the liquid crystal panel. The direct type backlight module includes at least one light source for emitting light beams, and a light guide plate having a first surface, an opposite second surface and at least one transmissive unit arranged on the first surface adjacent to the corresponding at least one light source. The at least one transmissive unit is configured for reflecting a first part of the light beams incident thereon, and allowing a second part of the light beams incident thereon to pass there-through.

Comparing with conventional direct type backlight module, the present backlight module has several advantages. As at least one transmissive unit is used, incident light beams can be split up into first and second parts, with the first part being

reflected away to be emitted from another part of the guide plate and the second part being directly transmitted. That is, the transmissive unit weakens the brightness of the regions of the light guide plate adjacent to the light source relative to the rest of the light guide plate. Therefore, the present backlight module has a high level of brightness uniformity.

Other advantages and novel features will become more apparent from the following detailed description of present display device, when taken in conjunction with the accompanying drawings.

## BRIEF DESCRIPTION OF THE DRAWINGS

Many aspects of the present direct type backlight module can be better understood with reference to the following drawings. The components in the drawings are not necessarily drawn to scale, the emphasis instead being placed upon clearly illustrating the principles of the present direct type backlight module. Moreover, in the drawings, like reference numerals designate corresponding parts throughout the several views.

FIG. 1 is an isometric view of a direct type backlight module in accordance with a first preferred embodiment;

FIG. 2 is a schematic, cross-sectional view of the direct type backlight module taken along line II-II of FIG. 1;

FIG. 3 is a schematic, enlarged view of a circled region III of the direct type backlight module of FIG. 2;

FIG. 4 is a schematic, cross-sectional view of a direct type backlight module in accordance with a second preferred embodiment;

FIG. 5 is a schematic, enlarged view of a circled region V of the direct type backlight module of FIG. 4;

FIG. 6 is an isometric view of a direct type backlight module in accordance with a third preferred embodiment;

FIG. 7 is a schematic, cross-sectional view of the direct type backlight module of FIG. 6, taken along line VII-VII thereof;

FIG. 8 is a schematic, cross-sectional view of a direct type backlight module in accordance with a fourth preferred embodiment; and

FIG. 9 is an isometric view of a liquid crystal display in accordance with a fifth preferred embodiment.

## DETAILED DESCRIPTION OF PREFERRED EMBODIMENTS

Reference will now be made to the drawings to describe a preferred embodiment of the present direct type backlight module and liquid crystal display, in detail.

Referring to FIGS. 1 to 3, a direct type backlight module 1, in accordance with a first preferred embodiment, is shown. The direct type backlight module 1 includes at least one light source 11 and a light guide plate 12 having a first surface 13 and an opposite second surface 14. The light guide plate 12 further includes at least one transmissive unit 16 arranged on the first surface 13, and the at least one transmissive unit 16 is positioned spatially corresponding to the at least one light source 11. In this embodiment, the first surface 13 is a light incident surface where light beams emitted from the light source 11 enter the light guide plate 12, and the second surface 14 is a light emitting surface where light beams exit from the light guide source 11.

The direct type backlight module 1 further includes a reflection plate 10 configured for reflecting the light beams from the at least one light source 11 to the light guide plate 12. The at least one light source 11 is mounted on the reflection plate 10 through corresponding light source base 15. In this

embodiment, the at least one light source **11** is for example a light emitting diode. The light source base **15** is made of a material with insulating and thermal properties.

The light guide plate **12** is utilized to diffuse the light beams coming from the at least one light source **11** and the light beams reflected by the reflection plate **10**. The light guide plate is made of polycarbonate (PC) or polymethyl methacrylate (PMMA). In the present embodiment, the at least one transmissive unit **16** is formed on the first surface **13** of the light guide plate **12**. Each transmissive unit **16** includes a block **18** extending from the light guide plate **12**. The block **18** may have a tapered surface or a semispherical surface. In this embodiment, the block **18** may have a tapered surface, the tapered surface tapering in a direction toward the corresponding at least one light source **11**.

Each transmissive unit **16** includes at least one transmissive layer **17** coated on the block **18** configured for reflecting the first part of the light beams emitted from the light source, and allowing the second part of the light beams emitted from the light source to pass therethrough. The at least one transmissive layer **17** has a reflective capability which gradually decreases in a direction away from the light source **11**. The transmissive layer **17** is made of a material selected from a group of magnesium fluoride (MgF<sub>2</sub>), titanium dioxide (TiO<sub>2</sub>), tantalum oxide (Ta<sub>2</sub>O<sub>5</sub>), or silicon dioxide (SiO<sub>2</sub>). In this embodiment, a first transmissive layer **17A** and a second transmissive layer **17B** applied onto the transmissive unit **16**. The first transmissive layer **17A** covers block **18**, and the second transmissive layer **17B** partially covers the first transmissive layer **17A**. The second transmissive layer **17B** covers part of the first transmissive layer **17A** adjacent to the light source **11**. The transmissive layer **17** transmits the second part of light beams emitted from the light source **11** and reflects the first part of light beams emitted from the light source **11**.

Compared to the conventional direct type backlight module, the present direct type backlight module **1** has following advantages. As at least one transmissive unit **16** is used, incident light beams can be split up into first and second parts, with the first part being reflected away to be emitted from another part of the light guide plate **12** and the second part being directly transmitted. That is, the transmissive unit **16** weakens the brightness of the regions of the light guide plate **12** adjacent to the light source **11** relative to the rest of the light guide plate **12**. Therefore, the present backlight module **1** has a high level of brightness uniformity.

Referring to FIGS. **4** and **5**, a direct type backlight module **2**, in accordance with a second preferred embodiment is shown. The direct type backlight module **2** is similar to the first embodiment, except that at least one transmissive unit **26** includes a recess **28** defined in the light guide plate **22** and at least one transmissive layer **27** covering the recess **28**. The at least one transmissive layer **27** includes a first transmissive layer **27A** covering the recess **28** and a second transmissive layer **27B** covering part of the first transmissive layer **27A**. The recess **28** may have a tapered surface or a hemispherical surface. The at least one transmissive layer **27** is similar to the transmissive layer **17** in the first preferred embodiment. In this embodiment, the first surface **24** is a light emitting surface. The at least one transmissive unit **26** can also include a block instead of a recess **28**.

Referring to FIGS. **6** and **7**, a direct type backlight module **3**, in accordance with a third preferred embodiment, is shown. The direct type backlight module **3** is similar to the first embodiment, except that at least one light source **31** is a cold cathode fluorescent lamp. The at least one transmissive unit **36** includes a protrusion extending from the light guide plate and at least one transmissive layer covering the protrusion.

The cross section of the protrusion may be semicircular-shaped, V-shaped, etc. The at least one transmissive layer is similar to the transmissive layer **17** in the first preferred embodiment. The at least one transmissive unit **36** may also include a groove instead of a protrusion. In this embodiment, the first surface is a light incident surface.

Referring to FIG. **8**, a direct type backlight module **4**, in accordance with a fourth preferred embodiment, is shown. The direct type backlight module **4** is similar to the first embodiment, except that it includes at least one cold cathode fluorescent lamp as a light source **41**, and at least one transmissive unit **46** includes a groove and at least one transmissive layer. The cross section of the groove may be semicircular-shaped, V-shaped, etc. The at least one transmissive layer is similar to the transmissive layer **17** in the first preferred embodiment. The at least one transmissive unit **46** can also include a protrusion instead of a groove. In this embodiment, the first surface **44** is a light emitting surface of the light guide plate.

Referring to FIG. **9**, a liquid crystal display **5**, in accordance with a fifth preferred embodiment is shown. The liquid crystal display **5** includes a liquid crystal panel **50**, a diffuser plate **52** arranged behind the liquid crystal panel **50**, and a direct type backlight module **51** arranged behind the light guide plate **52**. The direct type backlight module **51** can be any one of the direct type backlight modules as shown in FIG. **1**, FIG. **4**, FIG. **6**, or FIG. **8**.

It is to be understood that the above-described embodiment is intended to illustrate rather than limit the invention. Variations may be made to the embodiment without departing from the spirit of the invention as claimed. The above-described embodiments are intended to illustrate the scope of the invention and not restricted to the scope of the invention.

What is claimed is:

1. A direct type backlight module, comprising:
  - at least one light source for emitting light beams; and
  - a light guide plate having a first surface and a second surface at opposite sides thereof, and at least one transmissive unit arranged on the first surface adjacent to the corresponding at least one light source, the at least one transmissive unit comprising at least one transmissive layer coated thereon, the at least one transmissive layer having a reflective capability which gradually decreases in a direction away from the corresponding at least one light source, the at least one transmissive unit being configured for reflecting a first part of the incident light beams, and allowing a second part of the incident light beams to pass therethrough.
2. The direct type backlight module as claimed in claim **1**, wherein the at least one transmissive layer is configured for reflecting the first part of the incident light beams and allowing the second part of the incident light beams to pass therethrough.
3. The direct type backlight module as claimed in claim **1**, wherein the at least one transmissive layer is made of a material selected from a group consisting of magnesium fluoride, titanium dioxide, tantalum oxide and silicon dioxide.
4. The direct type backlight module as claimed in claim **1**, wherein the first surface of the light guide plate is selected from a group consisting of a light incident surface and a light emitting surface.
5. The direct type backlight module as claimed in claim **4**, wherein the at least one transmissive unit includes one of a block and a recess.
6. The direct type backlight module as claimed in claim **5**, wherein the one of the block and the recess has a tapered

surface, the tapered surface tapering in a direction toward the corresponding at least one light source.

7. The direct type backlight module as claimed in claim 1, wherein the one of the block and the recess has a hemispherical surface.

8. The direct type backlight module as claimed in claim 1, wherein the at least one light source is at least one light emitting diode.

9. The direct type backlight module as claimed in claim 1, wherein the at least one light source is at least one cold cathode fluorescent lamp.

10. The direct type backlight module as claimed in claim 9, wherein the at least one transfective unit includes one of a groove and a protrusion.

11. The direct type backlight module as claimed in claim 10, wherein a cross section of the one of the groove and the protrusion is one of V-shaped and semicircular-shaped.

12. The direct type backlight module as claimed in claim 1, further comprising a reflection plate arranged adjacent to the at least one light source, facing the light guide plate.

13. The direct type backlight module as claimed in claim 1, wherein each of the at least one transfective layer is configured for reflecting at least a part of the first part of the incident light beams, and allowing at least a part of the second part of the incident light beams to pass therethrough.

14. A liquid crystal display, comprising:  
a liquid crystal display panel; and  
a direct type backlight module arranged adjacent to the liquid crystal panel, the direct type backlight module comprising:  
at least one light source for emitting light beams; and at least one light source for emitting light beams; and  
a light guide plate having a first surface and a second surface at opposite sides thereof, and at least one transfective unit arranged on the first surface adjacent to the corresponding at least one light source, the at least one transfective unit comprising at least one transfective layer coated thereon, the at least one transfective layer having a reflective capability which gradually decreases in a direction away from the corresponding at least one light source, the at least one transfective unit being configured for reflecting a first part of the incident light

beams, and allowing a second part of the incident light beams to pass therethrough.

15. The liquid crystal display as claimed in claim 14, wherein the at least one transfective layer is configured for reflecting the first part of the incident light beams and allowing the second part of the incident light beams to pass therethrough.

16. The liquid crystal display as claimed in claim 14, wherein each of the at least one transfective layer is configured for reflecting at least a part of the first part of the incident light beams, and allowing at least a part of the second part of the incident light beams to pass therethrough.

17. The liquid crystal display as claimed in claim 14, wherein the first surface of the light guide plate is selected from a group consisting of a light incident surface and a light emitting surface.

18. A direct type backlight module, comprising:  
at least one light source for emitting light beams; and  
a light guide plate having a first surface and a second surface at opposite sides thereof, and at least one transfective unit arranged on the first surface adjacent to the corresponding at least one light source, the first surface being selected from a group consisting of a light incident surface and a light emitting surface, the at least one transfective unit comprising one of a block and a recess, the one of the block and the recess having a tapered surface, the tapered surface tapering in a direction toward the corresponding at least one light source, the at least one transfective unit being configured for reflecting a first part of the incident light beams, and allowing a second part of the incident light beams to pass therethrough.

19. The direct type backlight module as claimed in claim 18, wherein the at least one transfective unit comprises at least one transfective layer coated thereon and being configured for reflecting the first part of the incident light beams, and allowing the second part of the incident light beams to pass therethrough.

20. The direct type backlight module as claimed in claim 18, wherein the at least one transfective layer has a reflective capability which gradually decreases in a direction away from the corresponding at least one light source.

\* \* \* \* \*

专利名称(译)	直下式背光模组和使用它的液晶显示器		
公开(公告)号	<a href="#">US7515229</a>	公开(公告)日	2009-04-07
申请号	US11/478413	申请日	2006-06-28
[标]申请(专利权)人(译)	鸿海精密工业股份有限公司		
申请(专利权)人(译)	鸿海精密工业股份有限公司.		
当前申请(专利权)人(译)	GOLD CHARM LIMITED		
[标]发明人	CHANG JEN TSORNG		
发明人	CHANG, JEN-TSORNG		
IPC分类号	G02F1/1335 F21V7/04		
CPC分类号	G02B6/0018 G02B6/002 G02F1/133611 G02F1/133604 G02F2001/133607		
代理机构(译)	程, ANDREW C.		
助理审查员(译)	CHU, CHRIS		
优先权	200510036429.7 2005-08-05 CN		
其他公开文献	US20070030414A1		
外部链接	<a href="#">Espacenet</a> <a href="#">USPTO</a>		

摘要(译)

直下式背光模块 ( 1 ) 包括至少一个用于发射光束的光源 ( 11 ) , 以及具有第一表面 ( 13 ) , 相对的第二表面 ( 14 ) 和至少一个的导光板 ( 12 ) 透反单元 ( 16 ) 设置在与相应的至少一个光源相邻的第一表面上。至少一个透射反射单元被配置用于反射入射光束的第一部分, 并允许入射光束的第二部分通过。本背光模块具有高水平的亮度均匀性。

