



US007330232B2

(12) **United States Patent**
Jeon et al.

(10) **Patent No.:** **US 7,330,232 B2**
(45) **Date of Patent:** **Feb. 12, 2008**

(54) **VERTICALLY ALIGNED LIQUID CRYSTAL DISPLAY HAVING NEGATIVE COMPENSATION FILM**

(58) **Field of Classification Search** 349/178, 349/120, 118, 119, 117, 96, 123, 126, 128, 349/129

See application file for complete search history.

(75) Inventors: **Byoung-kun Jeon**, Daejeon (KR);
Sergey Belyaev, Daejeon (KR);
Jeong-su Yu, Daejeon (KR)

(56) **References Cited**

U.S. PATENT DOCUMENTS

4,889,412 A 12/1989 Clerc et al. 350/347 E
(Continued)

(73) Assignee: **LG.Chem, Ltd**, Seoul (KR)

FOREIGN PATENT DOCUMENTS

(*) Notice: Subject to any disclaimer, the term of this patent is extended or adjusted under 35 U.S.C. 154(b) by 37 days.

EP 0 239 433 A1 2/1987
(Continued)

OTHER PUBLICATIONS

(21) Appl. No.: **10/543,624**

PCT International Search Report, PCT/KR2004/000132, no date.

(22) PCT Filed: **Jan. 27, 2004**

Primary Examiner—Brian M. Healy

(86) PCT No.: **PCT/KR2004/000132**

(74) *Attorney, Agent, or Firm*—McKenna Long & Aldridge LLP

§ 371 (c)(1),

(2), (4) Date: **Jun. 26, 2006**

(57) **ABSTRACT**

(87) PCT Pub. No.: **WO2004/068225**

The present invention relates to a vertically aligned LCD (VA-LCD) comprising a negative compensation film including one or more of a first retardation film (+A-plate) satisfying the condition of $n_x > n_y = n_z$ and a first retardation film (-A-plate) satisfying the condition of $n_x < n_y = n_z$, and one or more of a second retardation film (-C-plate) satisfying the condition of $n_x = n_y > n_z$, wherein the first retardation film is arranged such that its optical axis is perpendicular to an optical absorption axis of a neighboring polarizing plate, and a total thickness retardation ($R_{-C} + R_{VA}$) including the thickness retardation of the second retardation film and the thickness retardation of a VA-panel has a negative value. The VA-LCD in accordance with the present invention improves contrast characteristics on a front surface and at a tilt angle and minimizes coloring in a black state according to the tilt angle.

PCT Pub. Date: **Aug. 12, 2004**

(65) **Prior Publication Data**

US 2006/0244884 A1 Nov. 2, 2006

(30) **Foreign Application Priority Data**

Jan. 28, 2003 (KR) 10-2003-0005467

(51) **Int. Cl.**

G02F 1/1335 (2006.01)

(52) **U.S. Cl.** 349/119; 385/118; 385/117; 385/129

15 Claims, 7 Drawing Sheets

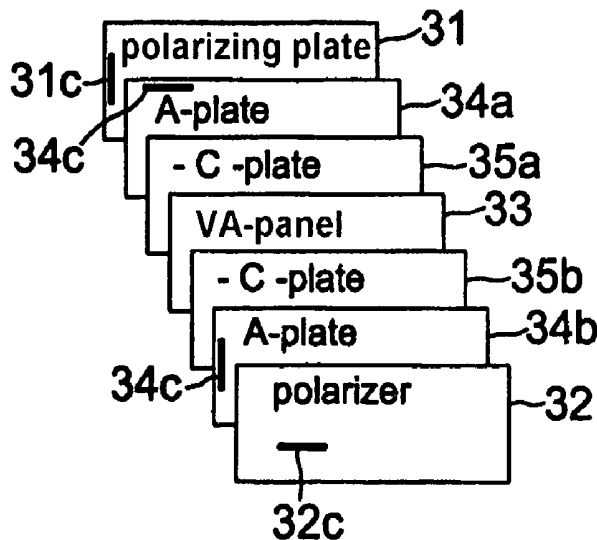

US 7,330,232 B2

Page 2

U.S. PATENT DOCUMENTS

6,141,075 A 10/2000 Ohmuro et al. 349/130
6,638,582 B1 10/2003 Uchiyama et al. 428/1.2
6,642,981 B1 11/2003 Ohmuro et al. 349/120
7,072,015 B2* 7/2006 Maeda 349/120
7,151,582 B2* 12/2006 Yoshida et al. 349/119
2004/0135949 A1* 7/2004 Maeda 349/119
2006/0244884 A1* 11/2006 Jeon et al. 349/119
2007/0177084 A1* 8/2007 Ishitani et al. 349/117

FOREIGN PATENT DOCUMENTS

EP 0 793 133 A2 9/1997

EP 1 118 885 A1 7/2001
JP 62-210423 9/1987
JP 10-123576 5/1998
JP 2001-042127 2/2001
JP 3330574 7/2002
KR 1997-0062749 9/1997
KR 10-0259111 3/2000
TW 520449 B 2/2003
TW 523620 B 3/2003
WO WO 95/00879 1/1995
WO WO 01/09649 A1 2/2001

* cited by examiner

FIGURE 1

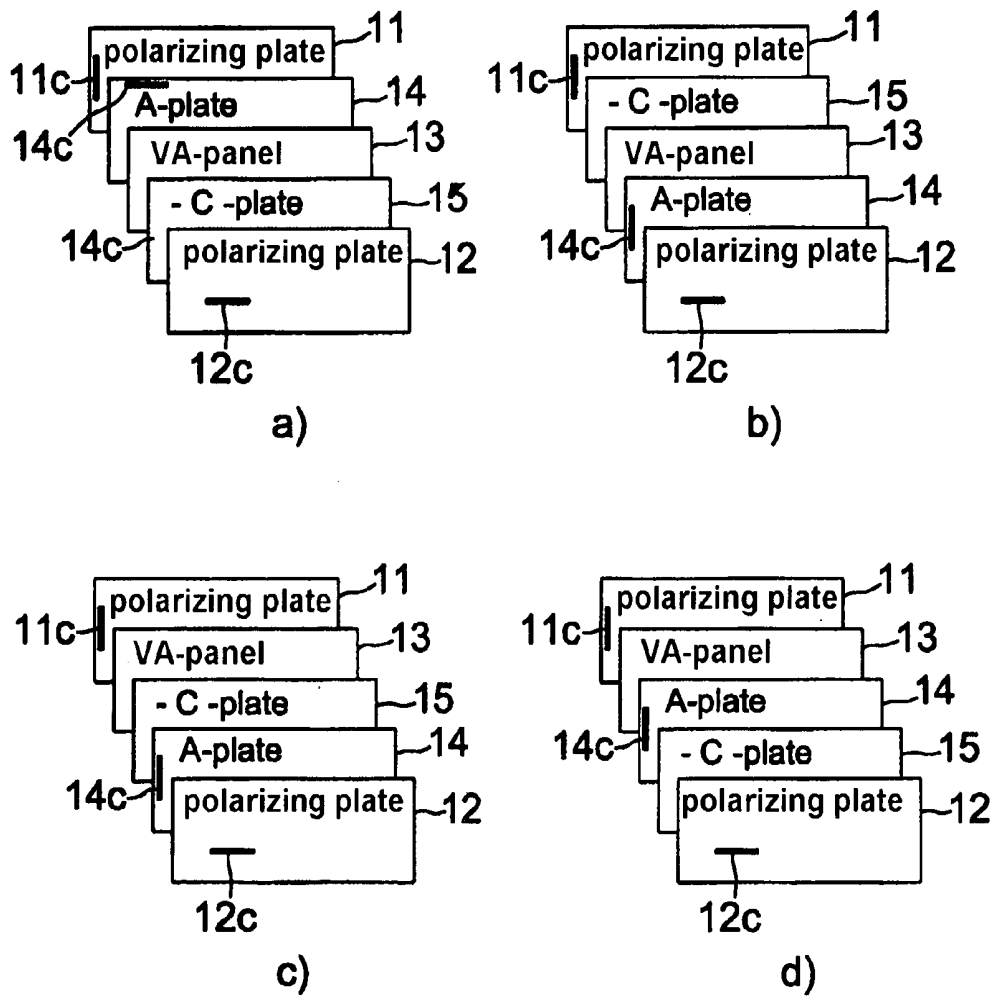

FIGURE 2

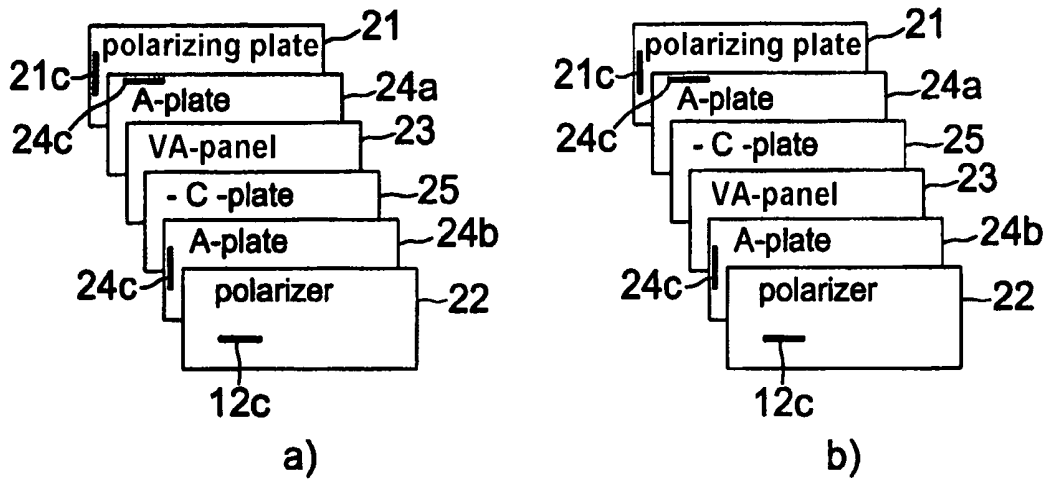

FIGURE 3

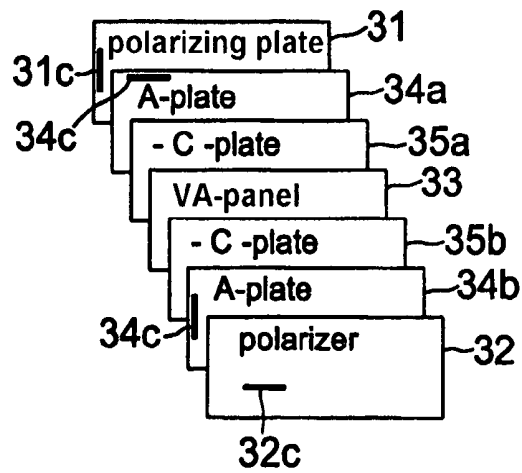

FIGURE 4

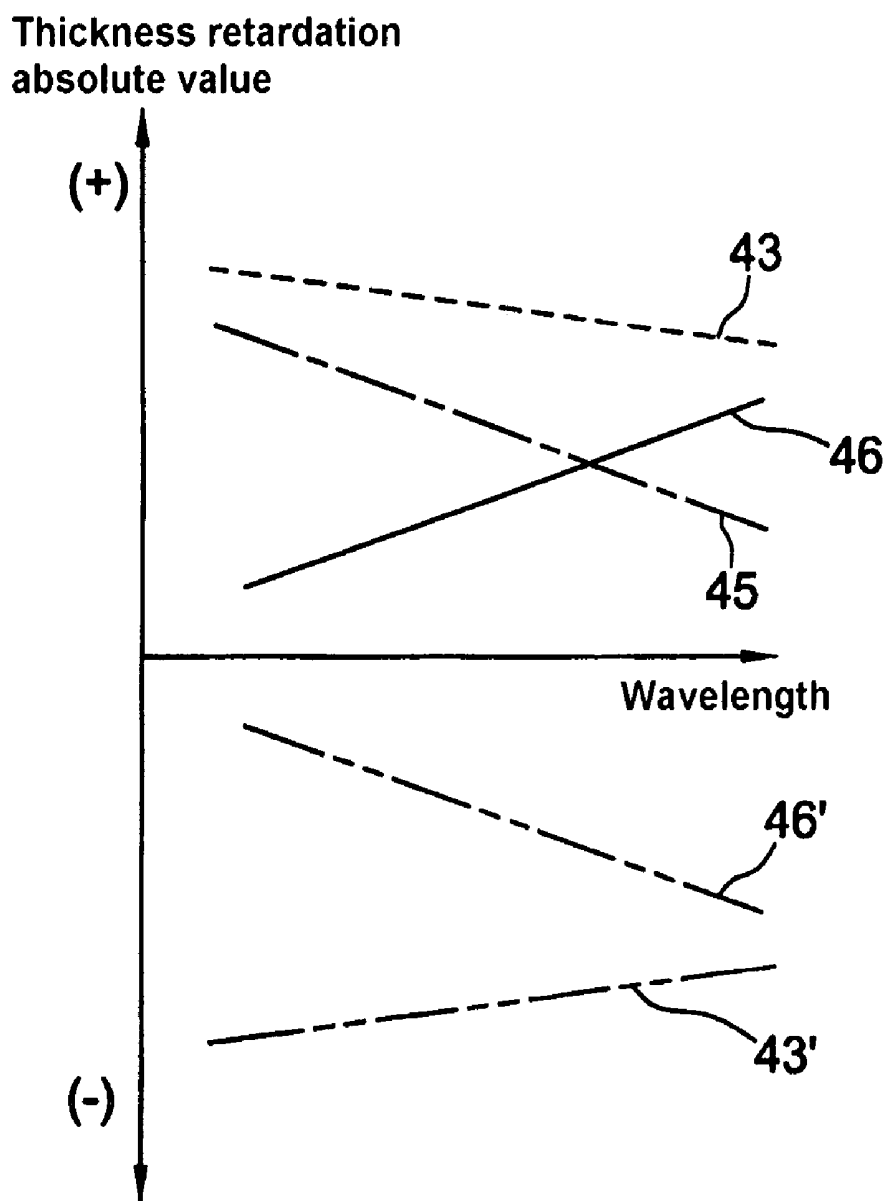

FIGURE 5

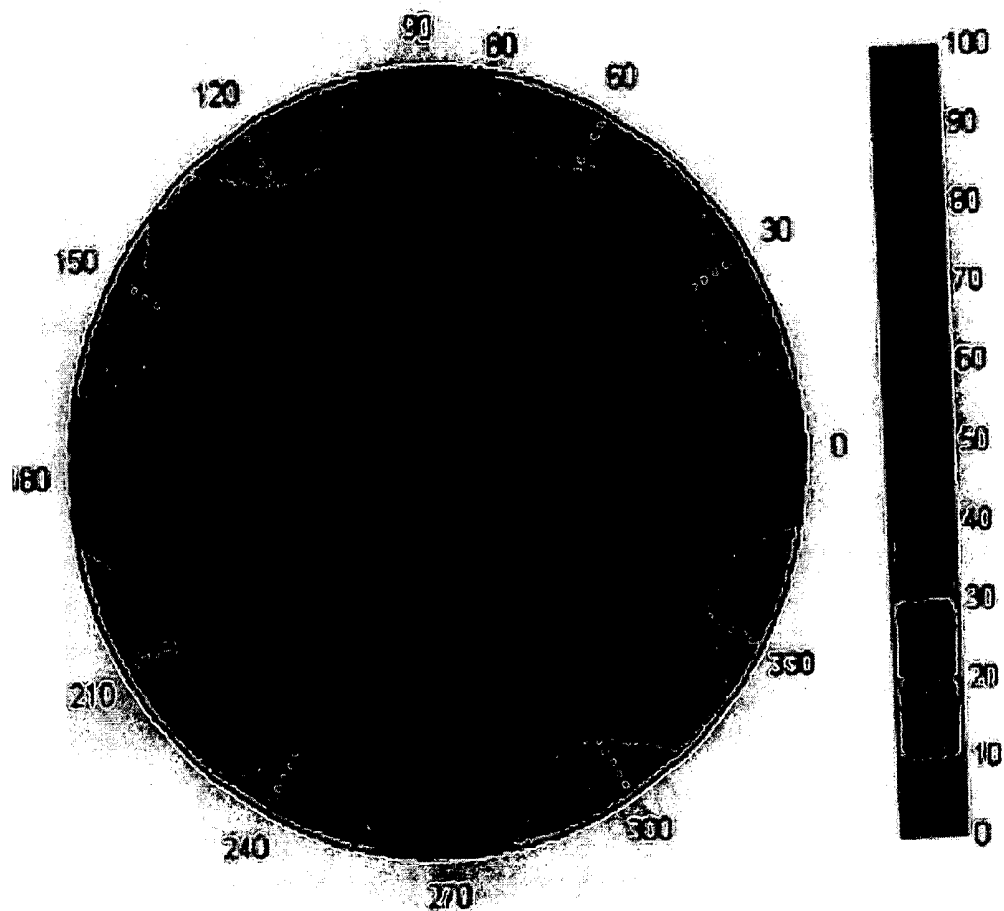

FIGURE 6

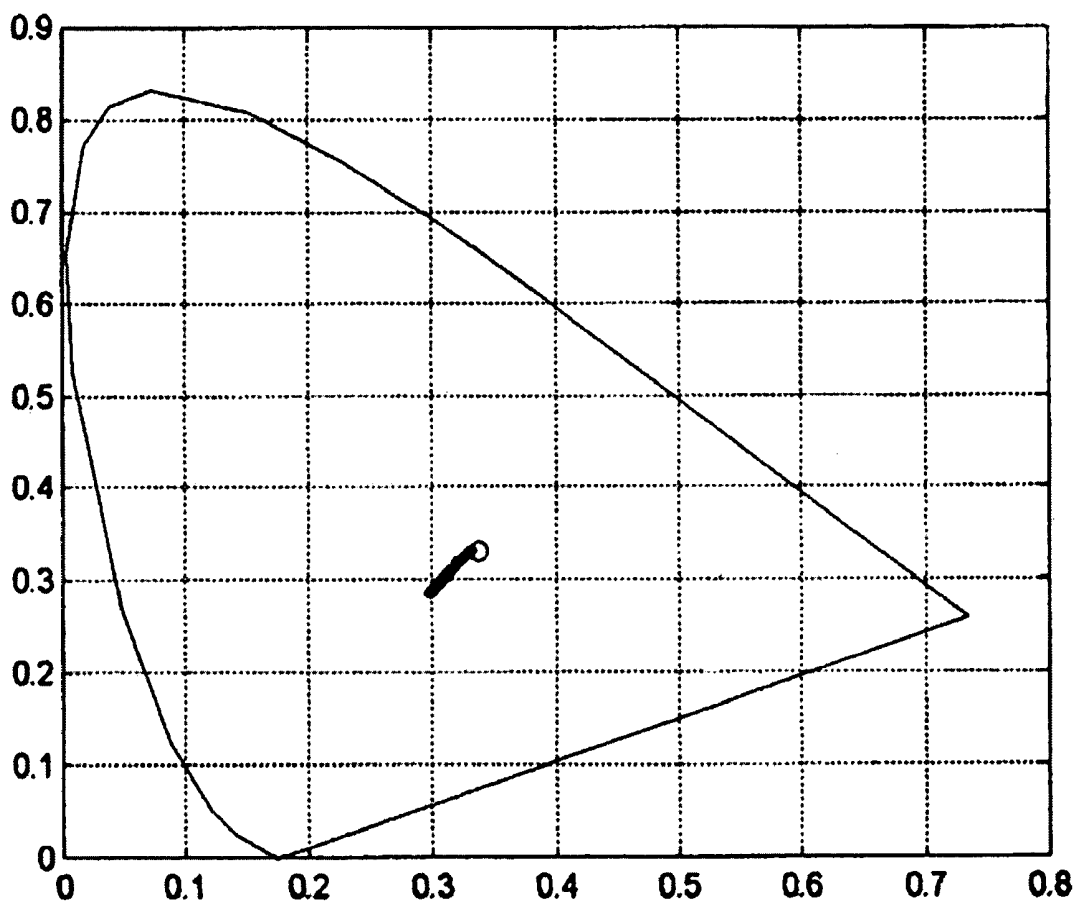

FIGURE 7

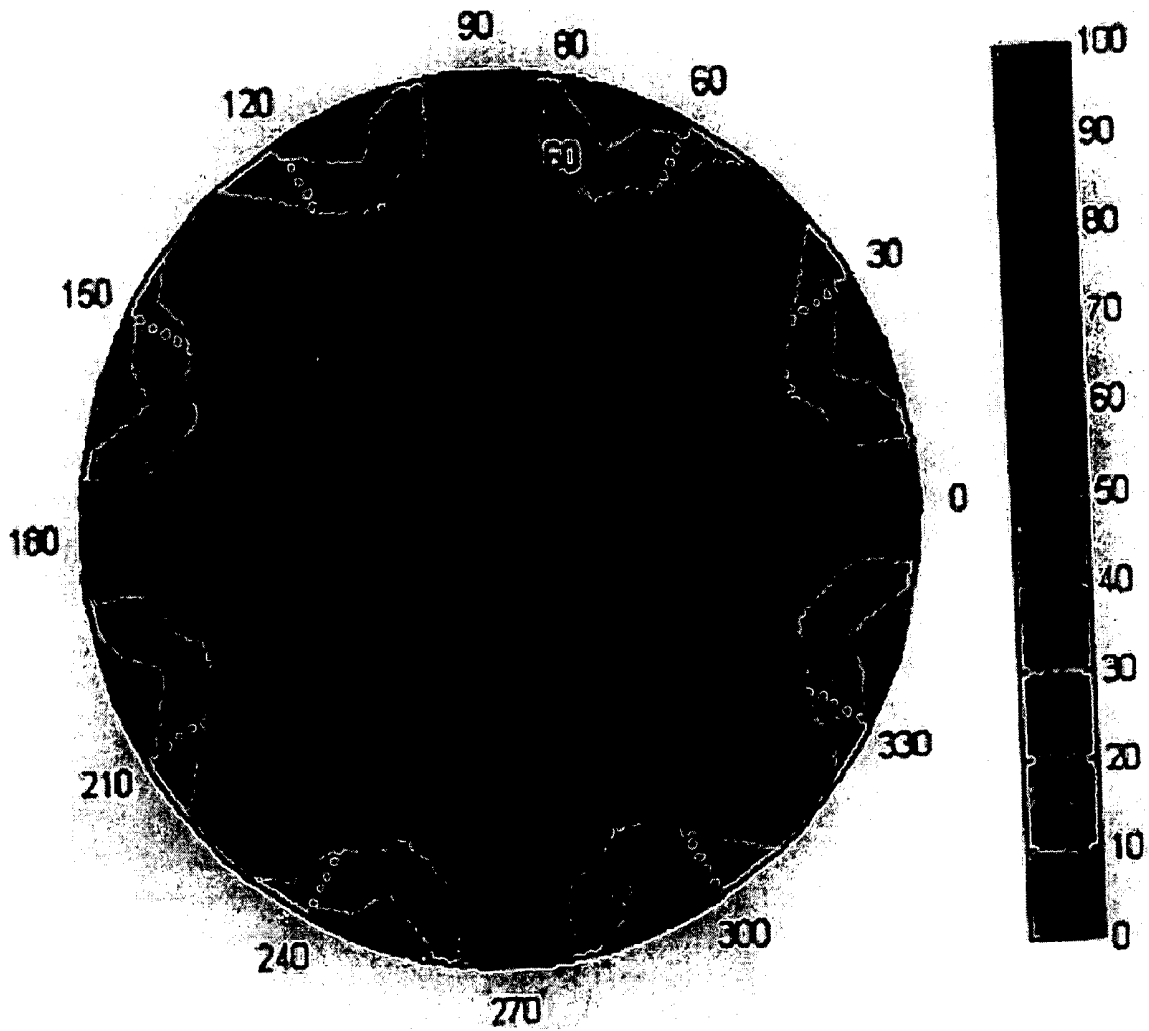
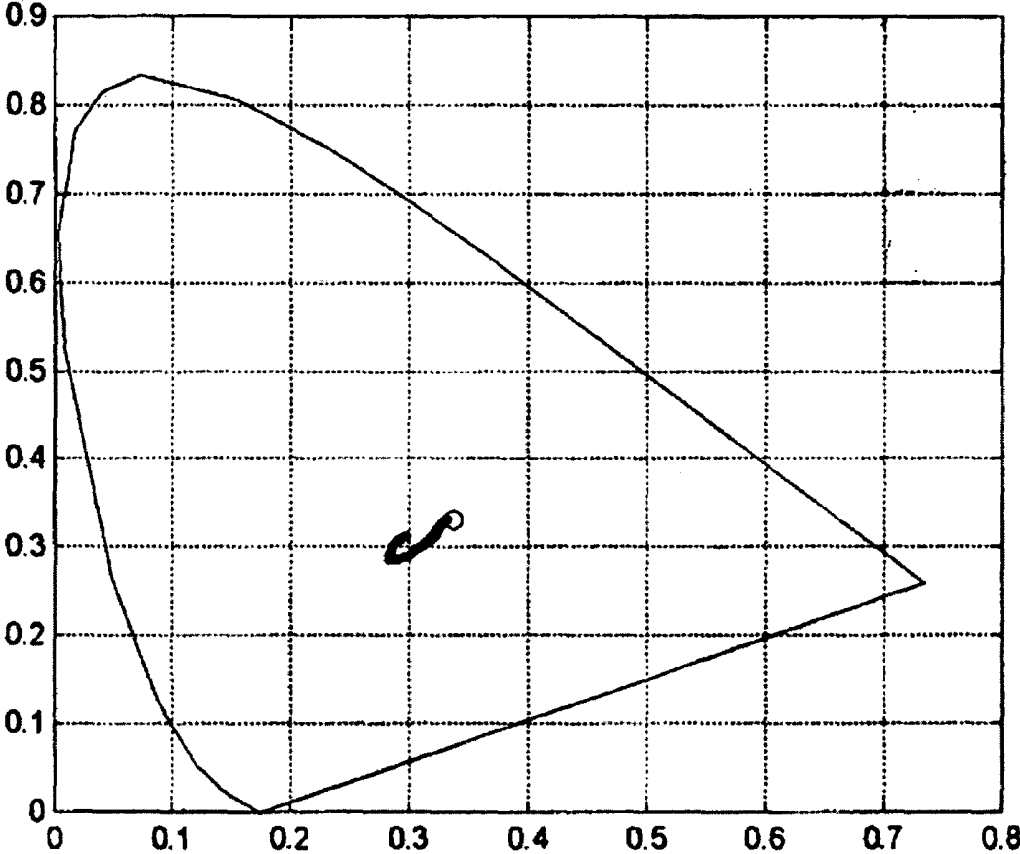

FIGURE 8



VERTICALLY ALIGNED LIQUID CRYSTAL DISPLAY HAVING NEGATIVE COMPENSATION FILM

This application claims priority to Korean Patent Appli- 5
cation No. 10-2003-0005467, filed Jan. 28, 2003, which is
hereby incorporated by reference.

TECHNICAL FIELD

The present invention relates to a vertically aligned liquid 10
crystal display (hereinafter, referred to as a "VA-LCD")
using a compensation film having a negative retardation
value so as to improve viewing angle characteristics.

BACKGROUND ART

As well known to those skilled in the art, a -C-plate 20
compensation film and an A-plate compensation film have
been used to compensate for a black state of a VA-LCD
under the condition that small drive voltage is applied. U.S.
Pat. No. 4,889,412 discloses a conventional VA-LCD using
the -C-plate compensation film.

However, the conventional VA-LCD using the -C-plate 25
compensation film does not completely compensate for a
black state, thus having a disadvantage such as a leakage of
light at a viewing angle.

Further, U.S. Pat. No. 6,141,075 discloses a conventional 30
VA-LCD comprising both the -C-plate compensation film
and the A-plate compensation film.

The above VA-LCD comprising both the -C-plate com- 35
pensation film and the A-plate compensation film more
completely achieves compensation of a black state under the
condition that small drive voltage is applied.

However, the above-described conventional VA-LCDs 40
require improvements of contrast and coloring at a front
surface and a tilt angle in order to completely compensate
for the black state.

DISCLOSURE OF THE INVENTION

Therefore, the present invention has been made in view of 45
the above problems, and it is an object of the present
invention to provide an achromatic VA-LCD comprising a
negative compensation film, in which contrast at a front
surface and a tilt angle of the VA-LCD filled with liquid
crystal having a positive or negative dielectric anisotropy is
improved, and coloring at the tilt angle in a black state is
minimized, thus improving viewing angle characteristics.

In accordance with the present invention, the above and 50
other objects can be accomplished by the provision of a
vertically aligned LCD (VA-LCD) in a multi-domain mode
or using a chiral additive, provided with a negative com-
pensation film, in which a vertically aligned panel (VA-
panel) is obtained by injecting liquid crystal having a 55
negative dielectric anisotropy ($\Delta\epsilon < 0$) or a positive dielectric
anisotropy ($\Delta\epsilon > 0$) into a gap between upper and lower glass
substrates, upper and lower polarizing plates are arranged
above the upper and lower surfaces of the VA-panel so that
optical absorption axes of the polarizing plates are perpen- 60
dicular to each other, and a cell gap in the range of 3 μm to
8 μm is maintained, comprising: the negative compensation
film including one or more of a first retardation film (+A-
plate) satisfying the condition of $n_x > n_y = n_z$, and a first
retardation film (-A-plate) satisfying the condition of 65
 $n_x < n_y = n_z$, and one or more of a second retardation film
(-C-plate) satisfying the condition of $n_x = n_y > n_z$, for forming

a liquid crystal cell, the n_x and n_y representing in-plane 70
refractive indexes between the VA-panel and the upper and
lower polarizing plates and the n_z representing a thickness
refractive index, wherein the first retardation film is arranged
such that an optical axis of the first retardation film is
perpendicular to an optical absorption axis of the neigh-
boring polarizing plate, and a total thickness retardation ($R_{-C}+$
 R_{VA}) including the thickness retardation of the second retar-
dation film and the thickness retardation of the VA-panel has
a negative value.

10 Preferably, the negative compensation film may include
one of a first retardation film (+A-plate or -A-plate) and one
of a second retardation film (-C-plate) in which one of the
first retardation film and the second retardation film may be
selectively arranged between the VA-panel and the upper 15
polarizing plate, and the other one of the second retardation
film is arranged between the VA-panel and the lower polar-
izing plate, or the first retardation film and the second
retardation film are arranged at one area between the VA-
panel and the upper polarizing plate, or between the VA-
panel and the lower polarizing plate.

Further, preferably, the negative compensation film may 20
include two of a first retardation film (+A-plates or
-A-plates) and one of a second retardation film (-C-plate) in
which one of the first retardation film and one of the second
retardation film may be arranged at one area between the
VA-panel and the upper polarizing plate, or between the 25
VA-panel and the lower polarizing plate, and the other one
of the first retardation film is arranged at the other area
between the VA-panel and the upper polarizing plate, or
between the VA-panel and the lower polarizing plate.

Moreover, preferably, the negative compensation film 30
may include two of a first retardation film (+A-plates or
-A-plates) and two of a second retardation film (-C-plate)
in which one of the first retardation film and one of the
second retardation film may be arranged between the VA-
panel and the upper polarizing plate, and the other one of the
first retardation film and the other one of the second retar-
dation film are arranged between the VA-panel and the lower
polarizing plate.

40 Preferably, a first retardation films (+A-plate and
-A-plate) may have a reversed wavelength dispersion in
which retardation is increased in proportion to the increase
of a wavelength in the range of visible rays. The first
retardation film (+A-plate) has an in-plane retardation (R_A
(550)) at a wavelength of 550 nm, which is in the range of
250 nm to 500 nm, and the first retardation film (-A-plate)
has an in-plane retardation ($R_A(550)$) at a wavelength of 550
nm, which is more than -250 nm (i.e. $-250 \text{ nm} \leq R_A(550) \leq 0$
nm). The ratio ($R_{A,450}/R_{A,550}$) of the in-plane retardations of
the first retardation film (A-plate) is in the range of 0.6 to
0.9; and the ratio ($R_{A,550}/R_{A,650}$) of the in-plane retardations
of the first retardation film (A-plate) is in the range of 1.1 to
1.5, wherein the $R_{A,450}$, $R_{A,550}$ and $R_{A,650}$ represent in-plane
retardations at wavelengths of 450 nm, 550 nm and 650 nm,
respectively.

Further, preferably, the total thickness retardation ($R_{-C}+$
 R_{VA}) including the thickness retardation of a second retar-
dation film and the thickness retardation of the VA-panel
may be in the range of -10 nm to -180 nm, being propor-
tional to a wavelength in the range of visible rays.

Moreover, preferably, a second retardation film (-C-plate) 65
may have a thickness retardation ($R_{-C}(550)$) at a wave-
length of 550 nm, which is in the range of -500 nm to -180
nm, and the absolute value ($|R_{-C}(550)|$) thereof, which is
larger than the absolute value ($|R_{VA}(550)|$) of the thickness
retardation of the VA-panel. The ratio (R_{450}/R_{550}) of the

thickness retardations of the second retardation film (-C-plate) is smaller than that of the VA-panel, and the ratio (R_{550}/R_{650}) of the thickness retardations of the second retardation film (-C-plate) is larger than that of the VA-panel, wherein the R_{450} , R_{550} and R_{650} represent thickness retardations of the second retardation film (-C-plate) at wavelengths of 450 nm, 550 nm and 650 nm, respectively. The ratio ($R_{-C,450}/R_{-C,550}$) of the thickness retardations of the second retardation film (-C-plate) is in the range of 0.9 to 1.2, and the ratio ($R_{-C,550}/R_{-C,650}$) of the thickness retardations of the second retardation film (-C-plate) is in the range of 0.9 to 1.2, wherein the $R_{-C,450}$, $R_{-C,550}$ and $R_{-C,650}$ represent thickness retardations at wavelengths of 450 nm, 550 nm and 650 nm, respectively.

Preferably, directors of liquid crystalline polymers of the VA-panel, under the condition that no voltage is applied to the VA-panel, may have a pretilt angle in the range of 75° to 90° between the upper and lower glass substrates. The pretilt angle is more preferably in the range of 87° to 90°, and most preferably in the range of 89° to 90°.

A liquid crystalline layer formed on the VA-panel may have a retardation at a wavelength of 550 nm, preferably in the range of 80 nm to 400 nm, and more preferably in the range of 80 nm to 300 nm. A rubbed direction of the liquid crystals injected into the VA-panel may have an angle of 45° with the optical absorption axes of the polarizing plates.

BRIEF DESCRIPTION OF THE DRAWINGS

The above and other objects, features and other advantages of the present invention will be more clearly understood from the following detailed description taken in conjunction with the accompanying drawings, in which:

FIGS. 1a to 1d are perspective views of a VA-LCD cell comprising a negative compensation film in accordance with a first embodiment of the present invention;

FIGS. 2a and 2b are perspective views of a VA-LCD cell comprising a negative compensation film in accordance with a second embodiment of the present invention;

FIG. 3 is a perspective view of a VA-LCD cell comprising a negative compensation film in accordance with a third embodiment of the present invention;

FIG. 4 is a graph showing the results of simulation for wavelength dependability of a thickness retardation of the VA-LCD cell, a thickness retardation of a C-plate, its absolute value, and a total thickness retardation in the VA-LCD cell comprising the negative compensation film of the present invention;

FIG. 5 is a diagram showing the result of simulation for a contrast ratio of the VA-LCD cell in accordance with the first embodiment of the present invention at a tilt angle in the range of 0° to 80° at all azimuth angles, in case that a white ray is applied;

FIG. 6 is a diagram showing the result of simulation for coloring of the VA-LCD cell in accordance with the first embodiment of the present invention in a black state at a tilt angle in the range of 0° to 80°, which is varied by an interval of 2°, at an azimuth angle of 45°, in case that a white ray is applied;

FIG. 7 is a diagram showing the results of simulation for a contrast ratio of the VA-LCD cells in accordance with the second and third embodiments of the present invention at a tilt angle in the range of 0° to 80° at all azimuth angles, in case that a white ray is applied; and

FIG. 8 is a diagram showing the results of simulation for coloring of the VA-LCD cells in accordance with the second and third embodiments of the present invention in a black

state at a tilt angle in the range of 0° to 80°, which is varied by an interval of 2°, at an azimuth angle of 45°, in case that a white ray is applied.

BEST MODE FOR CARRYING OUT THE INVENTION

Now, preferred embodiments of the present invention will be described in detail with reference to the annexed drawings.

FIGS. 1 to 3 respectively illustrate VA-LCD cells comprising a negative compensation film in accordance with each of Examples of the present invention.

FIGS. 1a to 1d are perspective views of a VA-LCD cell comprising a negative compensation film including one (hereinafter, +A-plate is selected) of a first retardation film (+A-plate or -A-plate) and one of a second retardation film (-C-plate), in accordance with Example 1 of the present invention. FIGS. 2a and 2b are perspective views of a VA-LCD cell comprising a negative compensation film including two of the first retardation film (+A-plates) and one of the second retardation film (-C-plate), in accordance with Example 2 of the present invention. FIG. 3 is a perspective view of a VA-LCD cell comprising a negative compensation film including two of the first retardation film (+A-plates) and two of the second retardation film (-C-plates), in accordance with Example 3 of the present invention.

EXAMPLE 1

As shown in FIGS. 1a to 1d, a VA-LCD in accordance with Example 1 of the present invention comprises a vertically aligned panel (VA-panel) 13 obtained by injecting liquid crystal having a negative dielectric anisotropy ($\Delta\epsilon < 0$) or a positive dielectric anisotropy ($\Delta\epsilon > 0$) into a gap between upper and lower glass substrates, two polarizing plates 11 and 12 arranged above the upper and lower surfaces of the VA-panel 13 so that optical absorption axes 11c and 12c are perpendicular to each other, and a negative compensation film including a first retardation film (+A-plate) 14 and a second retardation film (-C-plate) 15, which are arranged between the VA-panel 13 and the polarizing plates 11 and 12.

In FIG. 1a, a first retardation film (+A-plate) 14 is arranged between the VA-panel 13 and the lower polarizing plate 11, and a second retardation film (-C-plate) 15 is arranged between the VA-panel 13 and the upper polarizing plate 12. Here, the first retardation film (+A-plate) 14 is arranged such that an optical axis 14c of the first retardation film (+A-plate) 14 is perpendicular to the optical absorption axis 11c of the lower polarizing plate 11, thus serving as a compensation film for compensating for retardation.

In FIG. 1b, illustrating a modification of Example 1 shown in FIG. 1a, a first retardation film (+A-plate) 14 is arranged between the VA-panel 13 and the upper polarizing plate 12, and a second retardation film (-C-plate) 15 is arranged between the VA-panel 13 and the lower polarizing plate 11. Here, the first retardation film (+A-plate) 14 is arranged such that the optical axis 14c of the first retardation film (+A-plate) 14 is perpendicular to the optical absorption axis 12c of the upper polarizing plate 12.

In FIG. 1c illustrating another modification of Example 1 shown in FIG. 1a, a first retardation film (+A-plate) 14 and a second retardation film (-C-plate) 15 are arranged between the VA-panel 13 and the upper polarizing plate 12. Here, the first retardation film (+A-plate) 14 is arranged such that the

optical axis **14c** of the first retardation film (+A-plate) **14** is perpendicular to the optical absorption axis **12c** of the upper polarizing plate **12**.

In FIG. **1d** illustrating yet another modification of Example 1 shown in FIG. **1a**, a first retardation film (+A-plate) **14** and a second retardation film (-C-plate) **15** are arranged between the VA-panel **13** and the upper polarizing plate **12**. However, the positions of the first retardation film (+A-plate) **14** and the second retardation film (-C-plate) **15** are opposite to the positions of the first retardation film (+A-plate) **14** and the second retardation film (-C-plate) **15** in FIG. **1c**. Here, the first retardation film (+A-plate) **14** is arranged such that the optical axis **14c** of the first retardation film (+A-plate) **14** is perpendicular to the optical absorption axis **12c** of the upper polarizing plate **12**.

EXAMPLE 2

As shown in FIGS. **2a** and **2b**, a VA-LCD in accordance with Example 2 of the present invention comprises two polarizing plates **21** and **22** arranged such that optical absorption axes **21c** and **22c** are perpendicular to each other, a vertically aligned panel (VA-panel) **23** is interposed between the two polarizing plates **21** and **22**, and a negative compensation film including two of the first retardation film (+A-plate) **24a** and **24b** and one of the second retardation film (-C-plate) **25**, which are arranged between the VA-panel **23** and the polarizing plates **21** and **22**. One of the first retardation films (+A-plates) **24a** and **24b** and the second retardation film (-C-plate) **25** are arranged at one area between the VA-panel **23** and the upper polarizing plate **22**, or between the VA-panel **23** and the lower polarizing plate **21**, and the other one of the first retardation film is arranged at the other area between the VA-panel **23** and the upper polarizing plate **22**, or between the VA-panel **23** and the lower polarizing plate **21**.

In FIG. **2a**, a first retardation film (+A-plate) **24a** is arranged between the VA-panel **23** and the lower polarizing plate **21**, and a first retardation film (+A-plate) **24b** and a second retardation film (-C-plate) **25** are arranged between the VA-panel **23** and the upper polarizing plate **22**. Here, the first retardation film (+A-plate) **24a** is arranged between the VA-panel **23** and the lower polarizing plate **21** such that an optical axis **24c** of the first retardation film (+A-plate) **24a** is perpendicular to the optical absorption axis **21c** of the lower polarizing plate **21**, and the first retardation film (+A-plate) **24b** is arranged between the VA-panel **23** and the upper polarizing plate **22** such that an optical axis **24c** of the first retardation film (+A-plate) **24b** is perpendicular to the optical absorption axis **22c** of the upper polarizing plate **22**.

In FIG. **2b** illustrating a modification of Example 2 shown in FIG. **2a**, a first retardation film (+A-plate) **24b** is arranged between the VA-panel **23** and the upper polarizing plate **22**, and a first retardation film (+A-plate) **24a** and a second retardation film (-C-plate) **25** are arranged between the VA-panel **23** and the lower polarizing plate **21**. Here, the first retardation film (+A-plate) **24b** is arranged between the VA-panel **23** and the upper polarizing plate **22** such that the optical axis **24c** of the first retardation film (+A-plate) **24b** is perpendicular to the optical absorption axis **22c** of the upper polarizing plate **22**, and the first retardation film (+A-plate) **24a** is arranged between the VA-panel **23** and the lower polarizing plate **21** such that the optical axis **24c** of the first retardation film (+A-plate) **24a** is perpendicular to the optical absorption axis **21c** of the lower polarizing plate **21**.

EXAMPLE 3

As shown in FIG. **3**, a VA-LCD in accordance with Example 3 of the present invention comprises two polarizing plates **31** and **32** arranged such that optical absorption axes **31c** and **32c** are perpendicular to each other, a vertically aligned panel (VA-panel) **33** is interposed between the two polarizing plates **31** and **32**, and a negative compensation film including two of a first retardation film (+A-plates) **34a** and **34b** and two of a second retardation film (-C-plates) **35a** and **35b**, which are arranged between the VA-panel **33** and the polarizing plates **31** and **32**. One of the first retardation films (+A-plates) **34a** and **34b** and one of the second retardation films (-C-plates) **35a** and **35b** are arranged at one area between the VA-panel **33** and the upper polarizing plate **32** and between the VA-panel **33** and the lower polarizing plate **31**, and the other one of the first retardation films (+A-plates) **34a** and **34b** and the other one of the second retardation films (-C-plates) **35a** and **35b** are arranged at the other area between the VA-panel **33** and the upper polarizing plate **32** and between the VA-panel **33** and the lower polarizing plate **31**.

In FIG. **3**, a first retardation film (+A-plate) **34a** and a second retardation film (-C-plate) **35a** are arranged between the VA-panel **33** and the lower polarizing plate **31**, and a first retardation film (+A-plate) **34b** and a second retardation film (-C-plate) **35b** are arranged between the VA-panel **33** and the upper polarizing plate **32**. Here, the first retardation film (+A-plate) **34a** is arranged between the VA-panel **33** and the lower polarizing plate **31** such that an optical axis **34c** of the first retardation film (+A-plate) **34a** is perpendicular to the optical absorption axis **31c** of the lower polarizing plate **31**, and the first retardation film (+A-plate) **34b** is arranged between the VA-panel **33** and the upper polarizing plate **32** such that an optical axis **34c** of the first retardation film (+A-plate) **34b** is perpendicular to the optical absorption axis **32c** of the upper polarizing plate **32**.

The above-described VA-LCD in accordance with each of Example 1 to 3 of the present invention is a multi-domain vertically aligned LCD (MVA-LCD) or a VA-LCD using a chiral additive, which maintains a cell gap in the range of 3 μm to 8 μm and is obtained by forming the VA-panel by injecting liquid crystal having a negative dielectric anisotropy ($\Delta\epsilon < 0$) or a positive dielectric anisotropy ($\Delta\epsilon > 0$) into a gap between upper and lower glass substrates and arranging two polarizing plates above the upper and lower surfaces of the VA-panel so that optical absorption axes of the polarizing plates are perpendicular to each other. Here, since the negative compensation film including at least one of a first retardation film (+A-plate) and at least one of a second retardation film (-C-plate) is arranged between the VA-panel and the upper and lower polarizing plates, the VA-LCD has a characteristic such that a total thickness retardation ($R_{-C} + R_{VA}$) including a retardation of the second retardation film (-C-plate) and a retardation of the VA-panel has a negative value.

Two types (+A-plate and -A-plate) of a first retardation films, which are used as the compensation film of the respective embodiments of the present invention, have a reversed wavelength dispersion in which retardation is increased in proportion to the increase of a wavelength in the range of visible rays. One type (+A-plate) of the first retardation films has an in-plane retardation in the range of 250 nm to 500 nm at a wavelength of 550 nm (i.e., $250 \text{ nm} \leq R_A(550) \leq 500 \text{ nm}$), and the other type (-A-plate) of the

first retardation films has an in-plane retardation of more than -250 nm at a wavelength of 550 nm (i.e., -250 nm $\leq R_A(550) \leq 0$ nm).

The total thickness retardation ($R_{-C}+R_{VA}$) including the retardation of a second retardation film ($-C$ -plate) and the retardation of the VA-panel has a value in the range of -10 nm to -180 nm, being proportional to a wavelength in the range of visible rays. Particularly, the second retardation film ($-C$ -plate) has a thickness retardation in the range of -500 nm to -180 nm at a wavelength of 550 nm (i.e., -500 nm $\leq R_{-C}(550) \leq -180$ nm). The absolute value ($|R_{-C}(550)|$) of the thickness retardation of the second retardation film ($-C$ -plate) is larger than the absolute value ($|R_{VA}(550)|$) of the thickness retardation of the VA-panel. The ratio (R_{450}/R_{550}) of the thickness retardation of the second retardation film ($-C$ -plate) at a wavelength of 450 nm to the thickness retardation of the second retardation film ($-C$ -plate) at a wavelength of 550 nm is smaller than the ratio of the thickness retardation of the VA-panel at a wavelength of 450 nm to the thickness retardation of the VA-panel at a wavelength of 550 nm, and the ratio (R_{550}/R_{650}) of the thickness retardation of the second retardation film ($-C$ -plate) at a wavelength of 550 nm to the thickness retardation of the second retardation film ($-C$ -plate) at a wavelength of 650 nm is larger than the ratio of the thickness retardation of the VA-panel at a wavelength of 550 nm to the thickness retardation of the VA-panel at a wavelength of 650 nm.

Under the condition that no voltage is applied to the VA-panel in accordance with each of Examples of the present invention, directors of liquid crystalline polymers of the VA-panel have a pretilt angle in the range of 75° to 90° between the upper and lower substrates, preferably in the range of 87° to 90° , and more preferably in the range of 89° to 90° .

Further, a liquid crystalline layer formed on the VA-panel in accordance with each of the embodiments of the present invention has a retardation in the range of 80 nm to 400 nm at a wavelength of 550 nm, and preferably in the range of 80 nm to 300 nm. A rubbed direction of liquid crystals injected into the VA-panel has an angle of 45° with the optical absorption axis of the polarizing plate.

The polarizing plate applied to each of Examples of the present invention includes a TAC (Triacetate Cellulose) protective film having a designated thickness retardation, or one of other protective films having no designated thickness retardation.

FIG. 4 is a graph showing the results of simulation for wavelength dependability of a thickness retardation ($R_{VA}>0$) of the VA-panel, a thickness retardation ($R_{-C}<0$) of a second retardation film ($-C$ -plate), its absolute value, a total thickness retardation ($R_{VA}+R_{-C}<0$), and its absolute value. Here, there is applied an achromatic negative compensation film in which the total thickness retardation ($R_{VA}+R_{-C}<0$) of the retardations of the VA-panel and a second retardation film ($-C$ -plate) has a negative value.

The thickness retardation ($R_{-C,550}$) of a second retardation film ($-C$ -plate), which is required to compensate for the VA-LCD so as to solve a leakage of light caused by the VA-LCD, is obtained by the below equation.

$$R_{VA,550}+R_{-C,550}=-20 \text{ nm} \sim -150 \text{ nm} \text{ (mean value: } -85 \text{ nm)}$$

$$R_{VA,550}=(d \times \Delta n_{550})_{VA}$$

Here, $R_{VA,550}$ represents a thickness retardation of the VA-panel at a wavelength of 550 nm, and $R_{-C,550}$ represents a thickness retardation of the second retardation film ($-C$ -

plate) at a wavelength of 550 nm. A wavelength dispersion required by the second retardation film ($-C$ -plate) is calculated by the below equation.

$$\frac{(\Delta n_x/\Delta n_{550})_{VA} \times R_{VA,550} + (\Delta n_x/\Delta n_{550})_{-C} \times R_{-C,550}}{\text{nm}} = -85$$

Here, $(\Delta n_x/\Delta n_{550})_{VA}$ represents a wavelength dispersion of the thickness retardation of the VA-panel, and $(\Delta n_x/\Delta n_{550})_{-C}$ represents a wavelength dispersion of the thickness retardation of a second retardation film ($-C$ -plate).

A first retardation film is either a retardation film ($+A$ -plate), in which one of an in-plane refractive index (n_x) in an X direction and an in-plane refractive index (n_y) in an Y direction is the same as a thickness refractive index (n_z) and the other one of the in-plane refractive indexes (n_x and n_y) is larger than the thickness refractive index (n_z), i.e., the condition of $n_x > n_y = n_z$, or a retardation film ($-A$ -plate), in which one of an in-plane refractive index (n_x) in an X direction and an in-plane refractive index (n_y) in an Y direction is the same as a thickness refractive index (n_z) and the other one of the in-plane refractive indexes (n_x and n_y) is smaller than the thickness refractive index (n_z), i.e., the condition of $n_x < n_y = n_z$. The negative compensation film of the VA-LCD in accordance with the present invention includes one of the first retardation film ($+A$ -plate) satisfying the condition of $n_x > n_y = n_z$, and the first retardation film ($-A$ -plate) satisfying the condition of $n_x < n_y = n_z$. Here, one of the retardation films ($+A$ -plate and $-A$ -plate) included by the negative compensation film is arranged such that its optical axis is perpendicular to an optical absorption axis of a neighboring polarizing plate, and has a reversed wavelength dispersion in which retardation is increased in proportion to the increase of a wavelength. Preferably, the absolute value of the retardation of the first retardation film ($+A$ -plate) does not exceed 500 nm, and the absolute value of the retardation of the first retardation film ($-A$ -plate) does not exceed -250 nm (i.e., -250 nm $\leq R_A(550) \leq 0$ nm).

A second retardation film ($-C$ -plate) is designed such that the absolute value of the retardation of the second retardation film ($-C$ -plate) is larger than the absolute value of the retardation of the VA-panel, i.e., $|R_{-C}| > |R_{VA}|$, and the total thickness retardation ($R_{-C}+R_{VA}$) is in the range of -10 nm to -180 nm. Preferably, the absolute value of the total thickness retardation ($R_{-C}+R_{VA}$) is increased in proportion to the increase of a wavelength.

Hereinafter, optical characteristics of a first and a second retardation films are described.

A first retardation film ($+A$ -plate) has a ratio (R_{450}/R_{550}) of the retardations of 450 nm and 550 nm in the range of 0.6 to 0.9 , and a ratio (R_{550}/R_{650}) of the retardations at wavelength of 550 nm and 650 nm in the range of 1.1 to 1.5 . Here, R_{450} represents a retardation of the first retardation film ($+A$ -plate) at a wavelength of 450 nm, R_{550} represents a retardation of the first retardation film ($+A$ -plate) at a wavelength of 550 nm, and R_{650} represents a retardation of the first retardation film ($+A$ -plate) at a wavelength of 650 nm.

A second retardation film ($-C$ -plate) has a retardation (R_{-C}) in the range of -500 nm to -180 nm at a wavelength of 550 nm. The second retardation film ($-C$ -plate) has a ratio (R_{450}/R_{550}) of the retardations at wavelengths of 450 nm and 550 nm in the range of 0.95 to 1.2 , and a ratio (R_{550}/R_{650}) of the retardations at wavelength of 550 nm and 650 nm in the range of 0.95 to 1.2 . Here, R_{450} represents a retardation of the second retardation film ($-C$ -plate) at a wavelength of 450 nm, R_{550} represents a retardation of the second retardation

film (C-plate) at a wavelength of 550 nm, and R_{650} represents a retardation of the second retardation film (C-plate) at a wavelength of 650 nm.

FIGS. 5 to 8 show the results of simulation obtained in respective Examples of the present invention. FIGS. 5 and 7 show the results of simulation for a contrast ratio, using a color coordinate, obtained by the VA-LCD of the respective examples of the present invention at a tilt angle in the range of 0° to 80° at all azimuth angles, in case that a white ray is applied. FIGS. 6 and 8 show the results of simulation for coloring in a black state, using a color coordinate, obtained by the VA-LCD of the respective Examples of the present invention at a tilt angle in the range of 0° to 80°, which is varied by an interval of 2°, at an azimuth angle of 45°, in case that a white ray is applied.

Hereinafter, experimental examples for testing contrast characteristics of samples selected from the above Examples of the present invention will be described. Improvements of the contrast characteristics in the respective Examples will be more easily understood by the below experimental examples. The below experimental examples will be disclosed for illustrative purposes, but do not limit the subject matter of the present invention.

EXPERIMENTAL EXAMPLE 1

A sample employed by Experimental Example 1 was the VA-LCD using a compensation film including one of a first retardation film (+A-plate) and one of a second retardation film (-C-plate) in accordance with Example 1 of the present invention, as shown in FIG. 1a. The VA-LCD comprises the VA-panel 13 having a cell gap of 3 μm. Here, a pretilt angle of directors of liquid crystalline polymers is 89°, a dielectric anisotropy ($\Delta\epsilon$) is -4.9, a refractive anisotropy (Δn) is 0.099, and a wavelength dispersion ($\Delta n_{400}/\Delta n_{550}$) is 1.05.

Accordingly, a thickness retardation ($R_{VA,550}$) of the VA-panel 13 at a wavelength of 550 nm is 297 nm.

The above second retardation film (-C-plate) of the compensation film employed a polymer film having a thickness retardation ($R_{-C,550}$) of -354 nm and a wavelength dispersion ($R_{-C,450}/R_{-C,550}$) of 1.01.

The above first retardation film (+A-plate) of the compensation film employed a polymer film made of TAC having an in-plane retardation ($R_{A,550}$) of 395 nm and a wavelength dispersion ($R_{A,450}/R_{A,550}$) of 0.82.

Each of the two polarizing plates 11 and 12 employed a protective film made of COP (cycloolefin) instead of TAC (Triacetate cellulose).

FIG. 5 shows the result of simulation for a contrast ratio of the above VA-LCD at a tilt angle in the range of 0° to 80° at all azimuth angles, in case that a white ray is applied. FIG. 6 shows the result of simulation for coloring of the above VA-LCD in a black state at a tilt angle in the range of 0° to 80°, which is varied by an interval of 2°, at an azimuth angle of 45°, in case that a white ray is applied.

Table 1 comparatively shows contrasts of the sample (hereinafter, referred to as a "first sample") employed by Experimental Example 1 and a sample (hereinafter, referred to as a "second sample") serving as a comparative example. Here, in the first sample, the retardation (R_{VA}) of the VA-panel, the retardation (R_{-C}) of a second retardation film, the total retardation (R_{TOTAL}) and the retardation (R_A) were 297, -354, -57 and 395, respectively. On the other hand, in the second sample, the retardation (R_{VA}) of the VA-panel, the retardation (R_{-C}) of the second retardation film, the total retardation (R_{TOTAL}) and the retardation (R_A) were 297,

-500, +203 and 460, respectively. The minimum contrasts of the first and second samples at a tilt angle of 70° were 350 and 5, respectively.

TABLE 1

	R_{VA}	R_{-C}	R_{TOTAL}	R_A	Minimum contrast (at a tilt angle of 70°)
First sample (Experimental Example)	297	-354	-57	395	350
Second sample (Comparative Example)	297	-500	+203	460	5

In Table 1, the minimum contrasts of the first and second samples at a tilt angle of 70° were 350 and 5. Since the tilt angle of 70° has the minimum contrast, other tilt angles rather than the tilt angle of 70° have contrasts higher than the minimum contrast. Accordingly, the contrasts at other tilt angles rather than the tilt angle of 70° are higher than the minimum contrast.

FIRST MODIFIED EXAMPLE OF EXPERIMENTAL EXAMPLE 1

A sample employed by the first modified example of Experimental Example 1 was the VA-LCD using a compensation film including one of a first retardation film (+A-plate) and one of a second retardation film (-C-plate).

The VA-LCD of FIG. 1a comprises the VA-panel 13 having a cell gap of 3 μm. Here, a pretilt angle of directors of liquid crystalline polymers is 89°, a dielectric anisotropy ($\Delta\epsilon$) is -4.9, a refractive anisotropy (Δn) is 0.099, and a wavelength dispersion ($\Delta n_{400}/\Delta n_{550}$) is 1.05. Accordingly, the thickness retardation ($R_{VA,550}$) of the VA-panel 13 at a wavelength of 550 nm is 297 nm.

The above second retardation film (-C-plate) of the compensation film employed a polymer film made of TAC having a thickness retardation ($R_{-C,550}$) of -316 nm and a wavelength dispersion ($R_{-C,450}/R_{-C,550}$) of 1.01. The above first retardation film (+A-plate) of the compensation film employed a polymer film made of TAC having an in-plane retardation ($R_{A,550}$) of 316 nm and a wavelength dispersion ($R_{A,450}/R_{A,550}$) of 0.79.

FIG. 5 shows the result of simulation for contrast ratio of the above VA-LCD at a tilt angle in the range of 0° to 80° at all azimuth angles, in case that a white ray is applied. FIG. 6 shows the result of simulation for coloring of the above VA-LCD in a black state at a tilt angle in the range of 0° to 80°, which is varied by an interval of 20°, at an azimuth angle of 45°, in case that a white ray is applied.

SECOND MODIFIED EXAMPLE OF EXPERIMENTAL EXAMPLE 1

A sample employed by the second modified example of Experimental Example 1 was the VA-LCD using a compensation film including one of a first retardation film (-A-plate) and one of a second retardation film (-C-plate).

The VA-LCD of FIG. 1a comprises the VA-panel 13 having a cell gap of 3 μm. Here, a pretilt angle of directors of liquid crystalline polymers is 89°, a dielectric anisotropy ($\Delta\epsilon$) is -4.9, a refractive anisotropy (Δn) is 0.099, and a wavelength dispersion ($\Delta n_{400}/\Delta n_{550}$) is 1.05. Accordingly, the thickness retardation ($R_{VA,550}$) of the VA-panel 13 at a wavelength of 550 nm is 297 nm.

11

The above second retardation film (−C-plate) of the compensation film employed a polymer film made of TAC having a thickness retardation ($R_{-C,550}$) of −352 nm and a wavelength dispersion ($R_{-C,450}/R_{-C,550}$) of 1.01. The above first retardation film (−A-plate) of the compensation film employed a polymer film made of polystyrene having an in-plane retardation ($R_{A,550}$) of −150 nm and a wavelength dispersion ($R_{A,450}/R_{A,550}$) of 0.82.

Each of the two polarizing plates **11** and **12** employed a protective film made of COP (cycloolefin) instead of TAC (Triacetate cellulose).

FIG. **5** shows the result of simulation for contrast ratio of the above VA-LCD at a tilt angle in the range of 0° to 80° at all azimuth angles, in case that a white ray is applied. FIG. **6** shows the result of simulation for coloring of the above VA-LCD in a black state at a tilt angle in the range of 0° to 80°, which is varied by an interval of 2°, at an azimuth angle of 45°, in case that a white ray is applied.

THIRD MODIFIED EXAMPLE OF EXPERIMENTAL EXAMPLE 1

A sample employed by the third modified example of Experimental Example 1 was the VA-LCD using a compensation film including one of a first retardation film (−A-plate) and one of a second retardation film (−C-plate).

The VA-LCD of FIG. **1b** comprises the VA-panel **13** having a cell gap of 3 μm. Here, a pretilt angle of directors of liquid crystalline polymers is 89°, a dielectric anisotropy ($\Delta\epsilon$) is −4.9, a refractive anisotropy (Δn) is 0.099, and a wavelength dispersion ($\Delta n_{400}/\Delta n_{550}$) is 1.05. Accordingly, the thickness retardation ($R_{VA,550}$) of the VA-panel **13** at a wavelength of 550 nm is 297 nm.

The above second retardation film (−C-plate) of the compensation film employed a polymer film made of TAC having a thickness retardation ($R_{-C,550}$) of −390 nm and a wavelength dispersion ($R_{-C,450}/R_{-C,550}$) of 1.01. The above first retardation film (−A-plate) of the compensation film employed a polymer film made of polystyrene having an in-plane retardation ($R_{A,550}$) of −206 nm and a wavelength dispersion ($R_{A,450}/R_{A,550}$) of 0.92.

Each of the two polarizing plates **11** and **12** employed a protective film made of COP (cycloolefin) instead of TAC (Triacetate cellulose).

FIG. **5** shows the result of simulation for contrast ratio of the above VA-LCD at a tilt angle in the range of 0° to 80° at all azimuth angles, in case that a white ray is applied. FIG. **6** shows the result of simulation for coloring of the above VA-LCD in a black state at a tilt angle in the range of 0° to 80°, which is varied by an interval of 2°, at an azimuth angle of 45°, in case that a white ray is applied.

EXPERIMENTAL EXAMPLE 2

A sample employed by the second experimental example was the VA-LCD using a compensation film including two of a first retardation films (A-plates) and one of a second retardation films (−C-plates). The VA-LCD of FIG. **2a** comprises the VA-panel **23** having a cell gap of 3 μm. Here, a pretilt angle of directors of liquid crystalline polymers is 89°, a dielectric anisotropy ($\Delta\epsilon$) is −4.9, a refractive anisotropy (Δn) is 0.099, and a wavelength dispersion ($\Delta n_{400}/\Delta n_{550}$) is 1.05. Accordingly, the thickness retardation ($R_{VA,550}$) of the VA-panel **23** at a wavelength of 550 nm is 297 nm.

The above second retardation film (−C-plate) of the compensation film employed a polymer film having a thick-

12

ness retardation ($R_{-C,550}$) of −425 nm and a wavelength dispersion ($R_{-C,450}/R_{-C,550}$) of 1.02. Each of the above first retardation films (A-plates) of the compensation film employed a polymer film having an in-plane retardation ($R_{A,550}$) of 436 nm and a wavelength dispersion ($R_{A,450}/R_{A,550}$) of 0.82.

Each of the two polarizing plates **21** and **22** employed a protective film made of COP (cycloolefin) instead of TAC (Triacetate cellulose).

FIG. **7** shows the result of simulation for contrast ratio of the above VA-LCD at a tilt angle in the range of 0° to 80° at all azimuth angles, in case that a white ray is applied. FIG. **8** shows the result of simulation for coloring of the above VA-LCD in a black state at a tilt angle in the range of 0° to 80°, which is varied by an interval of 2°, at an azimuth angle of 45°, in case that a white ray is applied.

FIRST MODIFIED EXAMPLE OF EXPERIMENTAL EXAMPLE 2

A sample employed by the first modified example of Experimental Example 2 was the VA-LCD using a compensation film including two of a first retardation film (−A-plates) and one of a second retardation film (−C-plate).

The VA-LCD of FIG. **2b** comprises the VA-panel **23** having a cell gap of 3 μm. Here, a pretilt angle of directors of liquid crystalline polymers is 89°, a dielectric anisotropy ($\Delta\epsilon$) is −4.9, a refractive anisotropy (Δn) is 0.099, and a wavelength dispersion ($\Delta n_{400}/\Delta n_{550}$) is 1.05. Accordingly, the thickness retardation ($R_{VA,550}$) of the VA-panel **23** at a wavelength of 550 nm is 297 nm.

The above second retardation film (−C-plate) of the compensation film employed a polymer film made of TAC having a thickness retardation ($R_{-C,550}$) of −390 nm and a wavelength dispersion ($R_{-C,450}/R_{-C,550}$) of 1.01. Each of the above first retardation films (−A-plates) of the compensation film employed a polymer film made of polystyrene having an in-plane retardation ($R_{A,550}$) of −80 nm and a wavelength dispersion ($R_{A,450}/R_{A,550}$) of 0.82.

Each of the two polarizing plates **21** and **22** employed a protective film made of COP (cycloolefin) instead of TAC (Triacetate cellulose).

FIG. **7** shows the result of simulation for contrast ratio of the above VA-LCD at a tilt angle in the range of 0° to 80° at all azimuth angles, in case that a white ray is applied. FIG. **8** shows the result of simulation for coloring of the above VA-LCD in a black state at a tilt angle in the range of 0° to 80°, which is varied by an interval of 2°, at an azimuth angle of 45°, in case that a white ray is applied.

EXPERIMENTAL EXAMPLE 3

A sample employed by Experimental Example 3 was the VA-LCD using a compensation film including two of a first retardation film (+A-plates) and two of a second retardation film (−C-plates). The VA-LCD of FIG. **3** comprises the VA-panel **33** having a cell gap of 3 μm. Here, a pretilt angle of directors of liquid crystalline polymers is 89°, a dielectric anisotropy ($\Delta\epsilon$) is −4.9, a refractive anisotropy (Δn) is 0.099, and a wavelength dispersion ($\Delta n_{400}/\Delta n_{550}$) is 1.05. Accordingly, the thickness retardation ($R_{VA,550}$) of the VA-panel **33** at a wavelength of 550 nm is 297 nm.

Each of the above second retardation films (−C-plates) of the compensation film employed a polymer film having a thickness retardation ($R_{-C,550}$) of −212 nm and a wavelength dispersion ($R_{-C,450}/R_{-C,550}$) of 1.01. Each of the above first retardation films (+A-plates) of the compensation film

employed a polymer film having an in-plane retardation ($R_{A,550}$) of 436 nm and a wavelength dispersion ($R_{A,450}/R_{A,550}$) of 0.82.

Each of the two polarizing plates **31** and **32** employed a protective film made of COP (cycloolefin) instead of TAC (Triacetate cellulose).

FIG. 7 shows the result of simulation for contrast ratio of the above VA-LCD at a tilt angle in the range of 0° to 80° at all azimuth angles, in case that a white ray is applied. FIG. 8 shows the result of simulation for coloring of the above VA-LCD in a black state at a tilt angle in the range of 0° to 80° , which is varied by an interval of 2° , at an azimuth angle of 45° , in case that a white ray is applied.

FIRST MODIFIED EXAMPLE OF EXPERIMENTAL EXAMPLE 3

A sample employed by the first modified example of Experimental Example 3 was the VA-LCD using a compensation film including two of a first retardation film ($-A$ -plates) and two of a second retardation film ($-C$ -plates). The VA-LCD of FIG. 3 comprises the VA-panel **33** having a cell gap of 3 μm . Here, a pretilt angle of directors of liquid crystalline polymers is 89° , a dielectric anisotropy ($\Delta\epsilon$) is -4.9 , a refractive anisotropy (Δn) is 0.099, and a wavelength dispersion ($\Delta n_{400}/\Delta n_{550}$) is 1.05. Accordingly, the thickness retardation ($R_{VA,550}$) of the VA-panel **33** at a wavelength of 550 nm is 297 nm.

Each of the above second retardation films ($-C$ -plates) of the compensation film employed a polymer film made of TAC (Triacetate cellulose) having a thickness retardation ($R_{-C,550}$) of -195 nm and a wavelength dispersion ($R_{-C,450}/R_{-C,550}$) of 1.01. Each of the above first retardation films ($-A$ -plates) of the compensation film employed a polymer film made of polystyrene having an in-plane retardation ($R_{A,550}$) of -80 nm and a wavelength dispersion ($R_{A,450}/R_{A,550}$) of 0.82.

Each of the two polarizing plates **31** and **32** employed a protective film made of COP (cycloolefin) instead of TAC (Triacetate cellulose).

FIG. 7 shows the result of simulation for contrast ratio of the above VA-LCD at a tilt angle in the range of 0° to 80° at all azimuth angles, in case that a white ray is applied. FIG. 8 shows the result of simulation for coloring of the above VA-LCD in a black state at a tilt angle in the range of 0° to 80° , which is varied by an interval of 2° , at an azimuth angle of 45° , in case that a white ray is applied.

INDUSTRIAL APPLICABILITY

As apparent from the above description, the present invention provides a VA-LCD comprising a negative compensation film including at least one of a first retardation film (A -plate) and at least one of a second retardation film ($-C$ -plate), which compensates for a dark state at a tilt angle of the VA-LCD and minimizes coloring in dark, white and RGB states, thus improving viewing angle characteristics.

Although the preferred embodiments of the present invention have been disclosed for illustrative purposes, those skilled in the art will appreciate that various modifications, additions and substitutions are possible, without departing from the scope and spirit of the invention as disclosed in the accompanying claims.

What is claimed is:

1. A vertically aligned LCD (VA-LCD) in a multi-domain mode or using a chiral additive, provided with a negative compensation film, in which a vertically aligned panel

(VA-panel) is obtained by injecting liquid crystal having a negative dielectric anisotropy ($\Delta\epsilon < 0$) or a positive dielectric anisotropy ($\Delta\epsilon > 0$) into a gap between upper and lower glass substrates, upper and lower polarizing plates are arranged above the upper and lower surfaces of the VA-panel so that optical absorption axes of the polarizing plates are perpendicular to each other, and a cell gap in the range of 3 μm to 8 μm is maintained, comprising:

the negative compensation film including one or more of a first retardation film ($+A$ -plate) satisfying the condition of $n_x > n_y = n_z$, and a first retardation film ($-A$ -plate) satisfying the condition of $n_x < n_y = n_z$, and one or more of a second retardation film ($-C$ -plate) satisfying the condition of $n_x = n_y > n_z$, for forming a liquid crystal cell, wherein said n_x and n_y represent in-plane refractive indexes between the VA-panel and the upper and lower polarizing plates, and said n_z represents a thickness refractive index,

wherein said first retardation film is arranged such that an optical axis of said first retardation film is perpendicular to an optical absorption axis of the neighboring polarizing plate, and a total thickness retardation ($R_{-C} + R_{VA}$) including the thickness retardation of said second retardation film and the thickness retardation of the VA-panel has a negative value.

2. The VA-LCD according to claim 1, wherein

said negative compensation film includes one of said first retardation film ($+A$ -plate and $-A$ -plate) and one of said second retardation film ($-C$ -plate) in which one of said first retardation film and said second retardation film is selectively arranged between the VA-panel and the upper polarizing plate, and the other one of said second retardation film is arranged between the VA-panel and the lower polarizing plate, or said first retardation film and said second retardation film are arranged at one area between the VA-panel and the upper polarizing plate, or between the VA-panel and the lower polarizing plate.

3. The VA-LCD according to claim 1, wherein

said negative compensation film includes two of said first retardation film ($+A$ -plates or $-A$ -plates) and one of said second retardation film ($-C$ -plate) in which one of said first retardation film, and one of said second retardation film are arranged at one area between the VA-panel and the upper polarizing plate, or between the VA-panel and the lower polarizing plate, and the other one of said first retardation films is arranged at the other area between the VA-panel and the upper polarizing plate, or between the VA-panel and the lower polarizing plate.

4. The VA-LCD according to claim 1, wherein

said negative compensation film includes two of said first retardation film ($+A$ -plates or $-A$ -plates) and two of said second retardation film ($-C$ -plate) in which one of said first retardation film and one of said second retardation film are arranged between the VA-panel and the upper polarizing plate, and the other one of said first retardation film and the other one of said second retardation film are arranged between the VA-panel and the lower polarizing plate.

5. The VA-LCD according to claim 1, wherein

said first retardation film ($+A$ -plate and $-A$ -plate) has a reversed wavelength dispersion in which retardation is increased in proportion to the increase of a wavelength in the range of visible rays; and the total thickness retardation ($R_{-C} + R_{VA}$) including the thickness retardation of said second retardation film

15

and the thickness retardation of the VA-panel is in the range of -10 nm to -180 nm, being proportional to a wavelength in the range of visible rays.

6. The VA-LCD according to 5, wherein said first retardation film (+A-plate) has an in-plane retardation ($R_A(550)$) at a wavelength of 550 nm, which is in the range of 250 nm to 500 nm, and said first retardation film (-A-plate) has an in-plane retardation ($R_A(550)$) at a wavelength of 550 nm, which is more than -250 nm; and

said second retardation film (-C-plate) has a thickness retardation ($R_{-C}(550)$) at a wavelength of 550 nm, which is in the range of -500 nm to -180 nm, and the absolute value ($|R_{-C}(550)|$) thereof, which is larger than the absolute value ($|R_{VA}(550)|$) of the thickness retardation of the VA-panel.

7. The VA-LCD according to 5, wherein the ratio (R_{450}/R_{550}) of the thickness retardations of said second retardation film (-C-plate) is smaller than that of the VA-panel; and

the ratio (R_{550}/R_{650}) of the thickness retardations of said second retardation film (-C-plate) is larger than that of the VA-panel, wherein said R_{450} , R_{550} and R_{650} represent thickness retardations of said second retardation film (-C-plate) at wavelengths of 450 nm, 550 nm and 650 nm, respectively.

8. The VA-LCD according to 5, wherein directors of liquid crystalline polymers of the VA-panel, under the condition that no voltage is applied to the VA-panel, have a pretilt angle in the range of 75° to 90° between the upper and lower glass substrates.

9. The VA-LCD according to claim 8, wherein said pretilt angle is in the range of 87° to 90° .

16

10. The VA-LCD according to claim 8, wherein said pretilt angle is in the range of 89° to 90° .

11. The VA-LCD according to claim 5, wherein a liquid crystalline layer formed on said VA-panel has a retardation in the range of 80 nm to 400 nm at a wavelength of 550 nm.

12. The VA-LCD according to claim 11, wherein a liquid crystalline layer formed on said VA-panel has a retardation in the range of 80 nm to 300 nm at a wavelength of 550 nm.

13. The VA-LCD according to claim 5, wherein a rubbed direction of the liquid crystals injected into said VA-panel has an angle of 45° with the optical absorption axes of said polarizing plates.

14. The VA-LCD as set forth in claim 5, wherein the ratio ($R_{A,450}/R_{A,550}$) of the in-plane retardations of said first retardation film (A-plate) is in the range of 0.6 to 0.9; and

the ratio ($R_{A,550}/R_{A,650}$) of the in-plane retardations of said first retardation film (A-plate) is in the range of 1.1 to 1.5, wherein said $R_{A,450}$, $R_{A,550}$ and $R_{A,650}$ represent in-plane retardations at wavelengths of 450 nm, 550 nm and 650 nm, respectively.

15. The VA-LCD as set forth in claim 5, wherein: the ratio ($R_{-C,450}/R_{-C,550}$) of the thickness retardations of said second retardation film (-C-plate) is in the range of 0.9 to 1.2; and

the ratio ($R_{-C,550}/R_{-C,650}$) of the thickness retardations of said second retardation film (-C-plate) is in the range of 0.9 to 1.2, wherein said $R_{-C,450}$, $R_{-C,550}$ and $R_{-C,650}$ represent thickness retardations at wavelengths of 450 nm, 550 nm and 650 nm, respectively.

* * * * *

专利名称(译)	具有负补偿膜的垂直排列的液晶显示器		
公开(公告)号	US7330232	公开(公告)日	2008-02-12
申请号	US10/543624	申请日	2004-01-27
[标]申请(专利权)人(译)	乐金化学股份有限公司		
申请(专利权)人(译)	LG化学有限公司.		
当前申请(专利权)人(译)	LG化学有限公司. (起诉)		
[标]发明人	JEON BYOUNG KUN BELYAEV SERGEY YU JEONG SU		
发明人	JEON, BYOUNG-KUN BELYAEV, SERGEY YU, JEONG-SU		
IPC分类号	G02F1/1335 G02F1/13363 G02F1/139		
CPC分类号	G02F1/133634 G02F1/1393		
优先权	1020030005467 2003-01-28 KR		
其他公开文献	US20060244884A1		
外部链接	Espacenet USPTO		

摘要(译)

本发明涉及一种垂直排列的LCD (VA-LCD)，其包括负补偿膜，该负补偿膜包括满足 $n_x > n_y = n_z$ 条件的第一延迟膜 (+ A-板) 和第一延迟膜 (- 中的一个或多个。满足 $n_x = n_z$ 条件的第二延迟膜 (-C板) 中的一个或多个，其中第一延迟膜布置成使得其光学轴垂直于相邻偏振片的光学吸收轴，并且包括第二延迟膜的厚度延迟和VA-面板的厚度延迟的总厚度延迟 (R-C + RVA) 具有负值。根据本发明的VA-LCD改善了前表面上的对比度特性和倾斜角度，并且根据倾斜角度使黑色状态下的着色最小化。

