



US 20080068543A1

(19) **United States**

(12) **Patent Application Publication**
Mitsui et al.

(10) **Pub. No.: US 2008/0068543 A1**

(43) **Pub. Date: Mar. 20, 2008**

(54) **LIQUID CRYSTAL DISPLAY DEVICE**

Publication Classification

(75) Inventors: **Masashi Mitsui**, Anpachi-cho (JP);
Norio Koma, Motosu-gun (JP)

(51) **Int. Cl.**
G02F 1/1335 (2006.01)

(52) **U.S. Cl.** 349/114

Correspondence Address:
OLIFF & BERRIDGE, PLC
P.O. BOX 320850
ALEXANDRIA, VA 22320-4850

(57) **ABSTRACT**

A liquid crystal display device includes, in sequence, a first substrate, a liquid crystal layer, and a second substrate. The first substrate, the liquid crystal layer, and the second substrate are disposed in a subpixel having a transmissive portion for performing transmissive display and a reflective portion for performing reflective display. The first substrate includes a first electrode and a second electrode. The second substrate includes a third electrode. The first electrode and the second electrode are disposed in the transmissive portion and at least the first electrode and the third electrode are disposed in the reflective portion. Alignment of the liquid crystal layer is controlled by an electric field occurring between the first electrode and the second electrode in the transmissive portion and by an electric field occurring between the first electrode and the third electrode in the reflective portion.

(73) Assignee: **EPSON IMAGING DEVICES CORPORATION**, Azumino-shi (JP)

(21) Appl. No.: **11/902,036**

(22) Filed: **Sep. 18, 2007**

(30) **Foreign Application Priority Data**

Sep. 19, 2006 (JP) 2006-252658

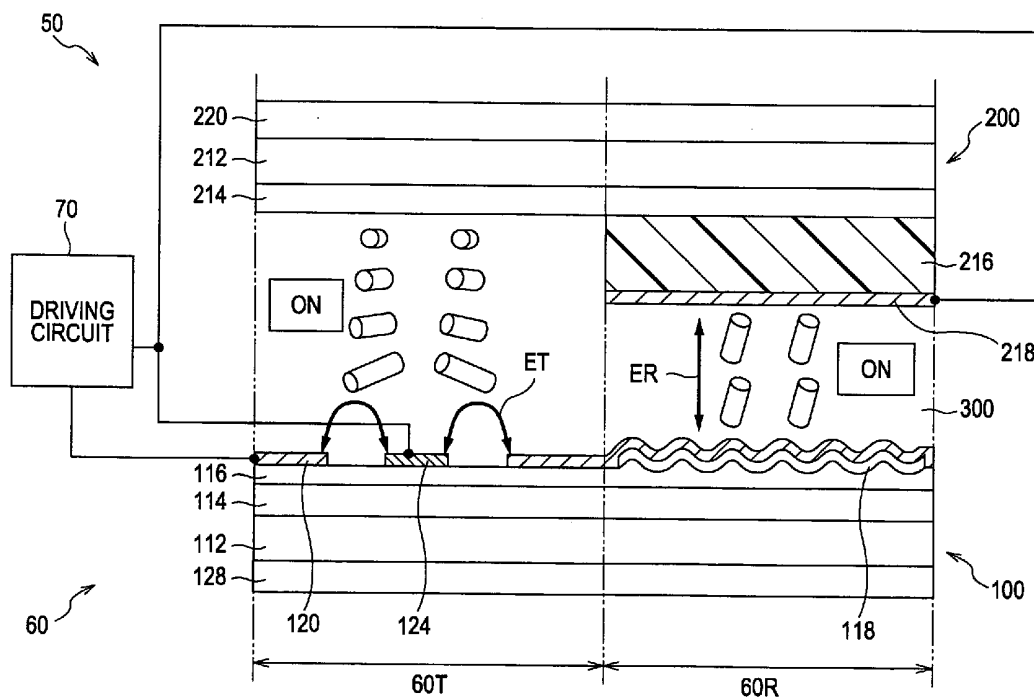

FIG. 1

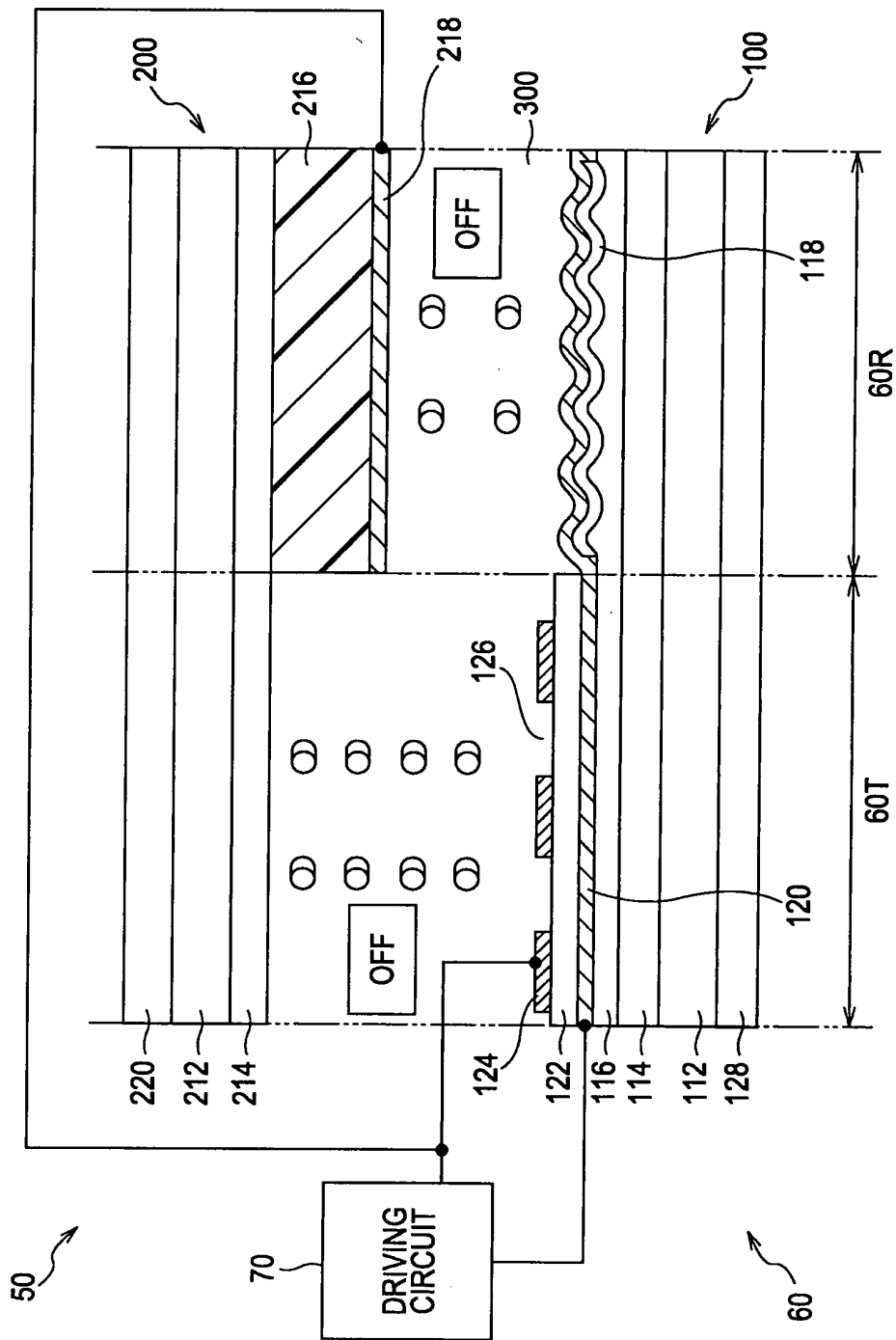
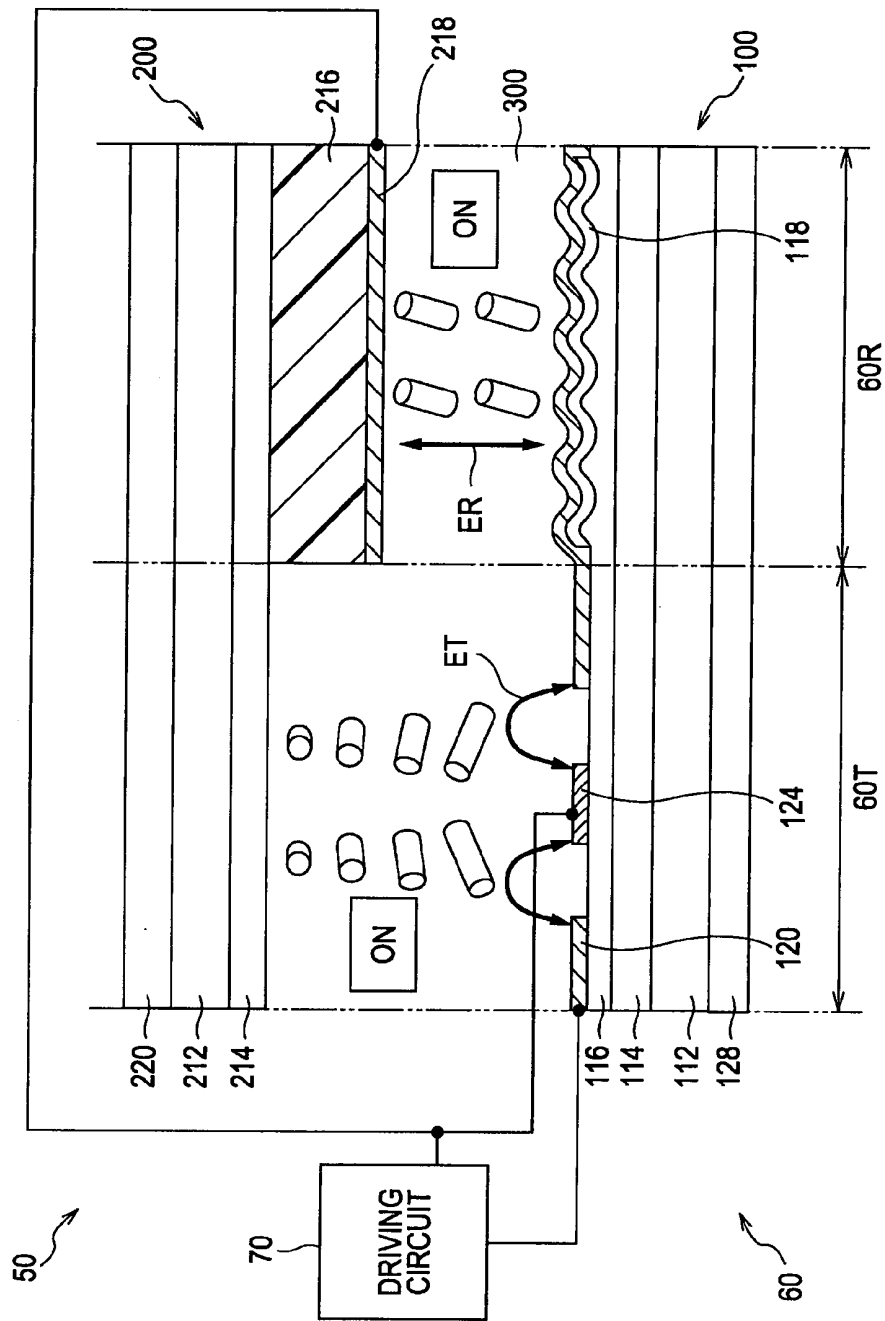

FIG. 3



LIQUID CRYSTAL DISPLAY DEVICE

BACKGROUND

[0001] 1. Technical Field

[0002] The present invention relates to a liquid crystal display device and, more specifically, to a liquid crystal display device that includes both a transmissive portion for performing transmissive display and a reflective portion for performing reflective display in one subpixel and includes two electrodes for controlling alignment of liquid crystal molecules in one substrate.

[0003] 2. Related Art

[0004] One example of a liquid crystal panel with a wide viewing angle is a liquid crystal panel of the fringe field switching (FFS) or in-plane switching (IPS) type. In these types, both a pixel electrode and a common electrode are provided in an element substrate, and liquid crystal molecules are rotated by control of an electric field occurring between both electrodes, thereby controlling alignment of the liquid crystal molecules.

[0005] Liquid crystal panels are broadly divided into the following types: a transmissive type which uses a backlight for displaying, a reflective type which uses reflection of outside light for displaying, and a transfective type which uses both transmissive and reflective structures built in one subpixel (see, for example, JP-A-2003-270627 and JP-A-2004-198922).

[0006] Existing transfective display devices of the twisted nematic (TN) type or electrically controlled birefringence (ECB) type suffer from an insufficient contrast and a narrow viewing angle. Transfective display devices of the vertical alignment (VA) type can have a high contrast and a wide viewing angle, but suffer from color changes in viewing from an angle.

[0007] In contrast to these TN or ECB display devices, transfective displays of the FFS or IPS type have excellent viewing-angle characteristics and have significantly small color changes in viewing from an angle, unlike VA transfective display devices. However, it is necessary to attach a retardation layer in order to perform both transmissive display and reflective display. This results in a problem of low contrast. In addition, the transfective FFS or IPS liquid crystal display device is thicker than transmissive FFS or IPS liquid crystal display devices.

SUMMARY

[0008] An advantage of some aspects of the invention is that it provides excellent display in a liquid crystal display device that includes both a transmissive portion for performing transmissive display and a reflective portion for performing reflective display in one subpixel and includes two electrodes for controlling alignment of liquid crystal molecules in one substrate.

[0009] According to an aspect of the invention, a liquid crystal display device includes, in sequence, a first substrate, a liquid crystal layer, and a second substrate. The first substrate, the liquid crystal layer, and the second substrate are disposed in a subpixel having a transmissive portion for performing transmissive display and a reflective portion for performing reflective display. The first substrate includes a first electrode and a second electrode. The second substrate includes a third electrode. The first electrode and the second electrode are disposed in the transmissive portion and at

least the first electrode and the third electrode are disposed in the reflective portion. Alignment of the liquid crystal layer is controlled by an electric field occurring between the first electrode and the second electrode in the transmissive portion and by an electric field occurring between the first electrode and the third electrode in the reflective portion.

[0010] In accordance with the above structure, the reflective portion can be controlled by the first electrode in the first substrate and the third electrode in the second substrate. Therefore, a transfective liquid crystal display device that includes a transmissive portion of the FFS type with a wide viewing angle can be realized. Since a retardation layer is not arranged in the transmissive portion, a contrast decrease caused by a retardation layer in the transmissive portion can be reduced.

[0011] The liquid crystal display device may preferably include a retardation layer incorporated in the reflective portion.

[0012] The retardation layer may preferably be included in the second substrate.

[0013] The retardation layer may preferably be a half-wave plate.

[0014] The first electrode, an insulating layer, and the second electrode may preferably be stacked in the first substrate in this sequence. The second electrode may preferably have a slit in an area facing the first electrode.

[0015] A cell gap in the reflective portion may preferably be thinner than a cell gap in the transmissive portion.

[0016] The cell gap in the reflective portion may preferably be thinner than the cell gap in the transmissive portion due to the retardation layer.

[0017] The same electric potential may preferably be applied to the second electrode and the third electrode.

[0018] With the above described structure, excellent display can be obtained in a liquid crystal display device that includes both a transmissive portion and a reflective portion in one subpixel and includes two electrodes for controlling alignment of liquid crystal molecules in one substrate.

BRIEF DESCRIPTION OF THE DRAWINGS

[0019] The invention will be described with reference to the accompanying drawings, wherein like numbers reference like elements.

[0020] FIG. 1 is a schematic diagram for describing a liquid crystal display device according to an embodiment of the invention.

[0021] FIG. 2 is a schematic diagram for describing the liquid crystal display device according to the embodiment of the invention.

[0022] FIG. 3 is a schematic diagram for describing a liquid crystal display device according to another embodiment of the invention.

DESCRIPTION OF EXEMPLARY EMBODIMENTS

[0023] Embodiments of the invention will be described below with reference to the accompanying drawings.

[0024] FIGS. 1 and 2 are schematic diagrams for describing a liquid crystal display device 50 according to an embodiment of the invention. The liquid crystal display device 50 includes a liquid crystal panel 60, a driving circuit 70 for driving the liquid crystal panel 60, and a backlight unit (not shown) arranged so as to face the liquid crystal

panel 60. In FIGS. 1 to 3, one sub-pixel (also called a dot) in the liquid crystal panel 60 in cross section is illustrated. In these drawings, for the sake of brevity, hatching for some components is omitted.

[0025] The liquid crystal panel 60 includes a transmissive section 60T for performing transmissive display and a reflective section 60R for performing reflective display in one subpixel. Each of the transmissive section 60T and the reflective section 60R indicates not only a two-dimensional region in plan view of a subpixel but also a three-dimensional region in the liquid crystal panel 60 defined by projecting the two-dimensional region in the direction of thickness of the liquid crystal panel 60, i.e., in the direction of placement of substrates 100 and 200, which will be described below.

[0026] In the present embodiment, a case in which the liquid crystal panel 60 performs FFS transmissive display and performs ECB reflective display is illustrated.

[0027] The liquid crystal panel 60 includes the element substrate 100, the opposed substrate 200 opposed to the element substrate 100, and liquid crystal (a liquid crystal layer) 300 disposed between the substrates 100 and 200. Liquid crystal molecules in the liquid crystal 300 are schematically illustrated in the drawings.

[0028] The element substrate 100 includes a light-transmitting substrate 112. The element substrate 100 also includes, inside the light-transmitting substrate 112, i.e., adjacent to the liquid crystal 300 with respect to the light-transmitting substrate 112, a circuit layer 114, a planarization layer 116, a reflective film 118, a first electrode 120, an insulating film 122, a second electrode 124, and an alignment layer (not shown).

[0029] The light-transmitting substrate 112 can include, for example, a transparent glass plate.

[0030] The circuit layer 114 is a layer where various elements and a circuit for driving a subpixel are formed. The circuit layer 114 can have, for example, a pixel thin film transistor (TFT) and various leads. It is noted that, although the details of the circuit are not described here, various circuits are applicable. The circuit layer 114 is disposed on the light-transmitting substrate 112 across the transmissive section 60T and the reflective section 60R.

[0031] The planarization layer 116 can be made of, for example, insulating and light-transmitting resin and is disposed on the circuit layer 114 and is adjacent to the liquid crystal 300. The planarization layer 116 is disposed across the transmissive section 60T and the reflective section 60R. A surface of the planarization layer 116 adjacent to the opposed substrate 200 is flat in the transmissive section 60T and has asperities in the reflective section 60R. The asperities can be formed by any method, for example, by forming the planarization layer 116 from a photoresist material and pattern-exposing and developing the photoresist material.

[0032] The reflective film 118 can be made of a material that can reflect outside light (visible light) for reflective display, for example, aluminum. The reflective film 118 is disposed in the reflective section 60R and arranged on the asperities of the planarization layer 116. The shape of a surface of the reflective film 118 adjacent to the opposed substrate 200 is similar to the shape of the asperities of the planarization layer 116.

[0033] The first electrode 120 can be made of a light-transmitting conductive material, for example, indium tin oxide (ITO). The first electrode 120 is disposed on the

planarization layer 116 so as to cover the reflective film 118. The first electrode 120 is disposed across the transmissive section 60T and the reflective section 60R. That is, the first electrode 120 is a common electrode for both the transmissive section 60T and the reflective section 60R. A surface of the first electrode 120 adjacent to the opposed substrate 200 is flat in the transmissive section 60T and has a shape similar to that of the asperities of the reflective film 118 and the planarization layer 116 in the reflective section 60R.

[0034] When the reflective film 118 is conductive, the first electrode 120 may cover only a part of the entire surface of the reflective film 118 as long as the first electrode 120 is connected to the reflective film 118. In other words, the reflective film 118 can function as a portion of the first electrode 120 in the reflective section 60R.

[0035] In FIGS. 1 to 3, for the sake of clarity, a connection between the first electrode 120 and the driving circuit 70 is schematically illustrated. An electric potential can be applied to the first electrode 120 via, for example, the pixel TFT in the circuit layer 114.

[0036] The insulating film 122 can be made of, for example, silicon oxide or silicon nitride. The insulating film 122 is disposed on the flat surface of the first electrode 120 in the transmissive section 60T. A surface of the insulating film 122 adjacent to the opposed substrate 200 is flat.

[0037] The second electrode 124 can be made of a light-transmitting conductive material, for example, ITO. The second electrode 124 is disposed on the insulating film 122 in the transmissive section 60T. The second electrode 124 faces the first electrode 120 with the insulating film 122 disposed therebetween. That is, the first electrode 120, the insulating film 122, and the second electrode 124 are stacked in this sequence. Both the second electrodes 124 and the first electrode 120 are provided in the element substrate 100, which means that both electrodes are situated at the same side with respect to the liquid crystal 300. The second electrode 124 has a slit 126 at a portion that faces the first electrode 120. In the present embodiment, a case in which the slit 126 extends in a substantially vertical direction in the drawings is illustrated. An electric field ET resulting from a potential difference between the first electrode 120 and the second electrode 124 occurs through the slit 126 and the insulating film 122 (see FIG. 2). The electric field ET controls the alignment state of the liquid crystal molecules in the liquid crystal 300 in the transmissive section 60T.

[0038] In FIGS. 1 to 3, for the sake of clarity, a connection between the second electrode 124 and the driving circuit 70 is schematically illustrated. An electric potential can be applied to the second electrode 124 via, for example, the leads in the circuit layer 114.

[0039] The alignment layer (not shown) is arranged so as to cover the second electrode 124, the insulating film 122, and the first electrode 120 and be in contact with the liquid crystal 300.

[0040] The opposed substrate 200 includes a light-transmitting substrate 212. The opposed substrate 200 also includes, inside the light-transmitting substrate 212, i.e., adjacent to the liquid crystal 300 with respect to the light-transmitting substrate 212, a color filter 214, a retardation film 216, a third electrode 218, and an alignment layer (not shown).

[0041] The light-transmitting substrate 212 can include, for example, a transparent glass plate.

[0042] The color filter 214 can be made of, for example, colored resin and is disposed across the transmissive section 60T and the reflective section 60R on the light-transmitting substrate 212. The color filter 214 colors light incident from the backlight adjacent to the element substrate 100 and light incident from the outside adjacent to the opposed substrate 200, thus causing a subpixel to light with a predetermined color. The color of the color filter 214 is set in accordance with a display color (a single color) of each subpixel. One unit constituted of adjacent subpixels of a plurality of colors is called a pixel.

[0043] In the present embodiment, a case in which the retardation film 216 corresponds to a half-wave plate is described. In this case, the direction of polarization of linearly polarized light can be rotated approximately 45° clockwise (or counterclockwise) by the retardation film 216. The retardation film 216 is more adjacent to the liquid crystal 300 than the color filter 214 and is disposed on the color filter 214 in the reflective section 60R. In this case, the retardation film 216 is incorporated in the liquid crystal panel 60. The term "incorporated" used herein indicates a state of being arranged between the light-transmitting substrates 112 and 212. For example, the pixel TFT is regarded as being incorporated in the liquid crystal panel 60.

[0044] The retardation film 216 can be formed by use of ultraviolet curable liquid crystal, which is liquid crystal curable by ultraviolet rays. More specifically, the retardation film 216 can be formed by forming an alignment layer (not shown) on the color filter 214, applying UV-curable liquid crystal in a liquid state to the alignment layer, and curing the UV-curable liquid crystal with ultraviolet radiation. In this case, the retardation film 216 includes the UV-curable liquid crystal, or, in addition thereto, the alignment layer. This alignment layer controls alignment of the UV-curable liquid crystal molecules, not alignment of the liquid crystal molecules in the liquid crystal 300. Various alignment layers can be used as the alignment layer for the UV-curable liquid crystal. For example, an optical alignment layer that carries out a function of aligning liquid crystal molecules in response to light irradiation is applicable. The use of such an optical alignment layer obviates the necessity of rubbing. The UV-curable liquid crystal functions as a retardation film by being UV-cured (cured by UV radiation). The phase difference is adjustable by changing the thickness of the UV-curable liquid crystal.

[0045] The third electrode 218 can be made of a light-transmitting conductive material, for example, ITO. The third electrode 218 is more adjacent to the liquid crystal 300 than the retardation film 216 and is disposed on the retardation film 216 in the reflective section 60R. The third electrode 218 faces the first electrode 120 with the liquid crystal 300 disposed therebetween. That is, the third electrode 218 and the first electrode 120 are disposed on opposite sides of the liquid crystal 300. An occurring electric field ER resulting from a potential difference between the third electrode 218 and the first electrode 120 controls the alignment state of the liquid crystal molecules in the liquid crystal 300 in the reflective section 60R (see FIG. 2).

[0046] The same potential as that applied to the second electrode 124 can be applied to the third electrode 218. In FIGS. 1 to 3, a case in which the leads branch off from the driving circuit 70 in directions that reach the third electrode 218 and second electrode 124 is schematically illustrated. As an alternative to this case, a structure may be used in which

a branch point is present in the liquid crystal panel 60 and the same potential can be applied to both the second electrode 124 and the third electrode 218. Alternatively, the third electrode 218 and the second electrode 124 may be provided with respective leads from the driving circuit 70, and the same potential may be output thereto from the driving circuit 70.

[0047] The alignment layer (not shown) is arranged so as to cover the third electrode 218, the retardation film 216, and the color filter 214 and be in contact with the liquid crystal 300.

[0048] The liquid crystal panel 60 further includes polarizers 128 and 220. The polarizer 128 is disposed outside the element substrate 100, that is, on a side opposite to the liquid crystal 300 with respect to the light-transmitting substrate 112. The polarizer 220 is disposed outside the opposed substrate 200, that is, on a side opposite to the liquid crystal 300 with respect to the light-transmitting substrate 212.

[0049] The driving circuit 70 is connected to the first electrode 120, the second electrode 124, and the third electrode 218 and includes various elements for generating a potential to be applied thereto and transmitting the potential. These various elements can be attached externally, incorporated, or implemented and can include a pixel TFT in the circuit layer 114. The driving circuit 70 generates the potential to be applied and applies the generated potential to each of the first electrode 120, the second electrode 124, and the third electrode 218 with a predetermined timing.

[0050] An example operation of the liquid crystal display device 50 will now be described with reference to FIGS. 1 and 2. Here, as previously above, a case in which FFS transmissive display and ECB reflective display are performed is illustrated. For the liquid crystal 300, dielectric anisotropy is, for example, positive, and anisotropy of refractive index (also called birefringence) Δn is, for example, 0.1.

[0051] The liquid crystal panel 60 is structured such that, when the potential difference between the first electrode 120 and the second electrode 124 is an OFF voltage, the transmissive display is in dark display, at which luminance is lowest, and, when the potential difference between the first electrode 120 and the third electrode 218 is an OFF voltage, the reflective display is in dark display (see FIG. 1). The luminance in the transmissive display corresponds to transmittance, and the luminance in the reflective display corresponds to reflectance. The dark display is also called a dark state and black display. A state in which the luminance is highest is referred to as bright display. The bright display is also called a bright state and white display. The OFF voltage is a voltage that realizes the dark display or bright display and produces almost none of the electric fields ET and ER. In contrast to this, a voltage that realizes the dark display or bright display and produces the electric fields ET and ER larger than when the OFF voltage is applied is referred to as an ON voltage.

[0052] Therefore, in the present embodiment, both the transmissive section 60T and the reflective section 60R operate in the normally black mode, and the pixels as a whole also operates in the normally black mode. This structure is practicable by adjustment of a material of the liquid crystal 300, an alignment state of the liquid crystal molecules in the liquid crystal 300 during application of the OFF voltage (a so-called initial alignment state), the direc-

tion of rubbing of the alignment layer, and characteristics and arrangement of the polarizers **128** and **220** and the retardation film **216**.

[0053] Since the same potential is applied to the second electrode **124** and the third electrode **218** in the liquid crystal display device **50**, the transmissive section **60T** and the reflective section **60R** become the dark display at the same time in response to application of the OFF voltage. That is, the entire pixels become the dark display. The transmissive section **60T** and the reflective section **60R** can become the bright display at the same time in response to application of the ON voltage, and, at this time, the entire pixels become the bright display (see FIG. 2).

[0054] A more specific example operation will be described below.

[0055] For example, the liquid crystal molecules in the liquid crystal **300** are initially aligned (that is, are aligned in a substantially vertical direction in the drawings) such that the major axis of the liquid crystal molecules is substantially parallel to the surface of each of the first electrode **120**, the second electrode **124**, and the third electrode **218** and is substantially parallel to a direction in which the slit **126** extends during application of the OFF voltage in the transmissive section **60T** and the reflective section **60R**. The rubbing direction in the transmissive section **60T** and that in the reflective section **60R** are set at the same direction. The polarizer **128** is arranged such that its polarization axis is substantially perpendicular to the major axis of the liquid crystal molecules in the initial alignment state. The polarizer **220** is arranged such that its polarization axis is substantially perpendicular to the polarization axis of the polarizer **128** (so-called perpendicular arrangement).

[0056] In this case, for the transmissive display, light from the backlight adjacent to the element substrate **100** enters the polarizer **128** and then linearly polarized light that is substantially perpendicular to the major axis of the liquid crystal molecules exits from the polarizer **128**. From the relationship between the polarization direction of the linearly polarized light and the alignment direction of the liquid crystal molecules, birefringence of the liquid crystal **300** have little effect on the linearly polarized light, the linearly polarized light reaches the polarizer **220** while maintaining its polarized state. Because the polarization direction of the linearly polarized light is substantially perpendicular to the polarization axis of the polarizer **220**, the linearly polarized light cannot pass through the polarizer **220**. As a result, the transmissive display is in dark display.

[0057] For the reflective display, light from the outside adjacent to the opposed substrate **200** enters the polarizer **220** and then linearly polarized light that is substantially parallel to the major axis of the liquid crystal molecules exits from the polarizer **220**. The polarization direction is rotated approximately 45° by the previously described operation of the retardation film **216**, and the linearly polarized light enters the liquid crystal **300** in this polarized state. The liquid crystal **300** in the reflective section **60R** has been adjusted so as to function similarly to a quarter-wave plate using their birefringence. In this case, the linearly polarized light is transformed to clockwise (or counterclockwise) substantially circularly polarized light. The substantially circularly polarized light transformed by the liquid crystal **300** after having been externally input is reflected by the reflective film **118**, passes through the liquid crystal **300**, and is transformed to linearly polarized light whose polarization is

rotated approximately 90° with respect to linearly polarized light entering the liquid crystal **300** from the retardation film **216**. Then, the light is transformed by the retardation film **216** to light whose polarization direction is rotated approximately -45° and reaches the polarizer **220**. Because the polarization direction of the linearly polarized light that has returned the polarizer **220** is substantially perpendicular to the polarization axis of the polarizer **220**, the linearly polarized light cannot pass through the polarizer **220**. As a result, the reflective display is in dark display.

[0058] When the voltage is changed from the OFF to ON voltage, both the transmissive display and the reflective display leave the dark display (see FIG. 2). The luminance in each of the transmissive display and the reflective display increases with an increase in the magnitude of an applied voltage.

[0059] In the transmissive section **60T**, in response to application of the ON voltage, liquid crystal molecules near the element substrate **100** are aligned in a direction that is substantially parallel to the surface of each of the first electrode **120** and the second electrode **124** and substantially perpendicular to a direction in which the slit **126** extends. In contrast, liquid crystal molecules near the opposed substrate **200** remain in the initial alignment state.

[0060] Therefore, the liquid crystal molecules in the transmissive section **60T** are aligned as a whole so as to be twisted approximately 90° around the normal of each of the second electrode **124** and the first electrode **120**. In this case, the polarization direction of light linearly polarized by the polarizer **128** after having been input from the backlight is substantially parallel to the major axis of the liquid crystal molecules near the element substrate **100**, and the linearly polarized light is optically rotated in accordance with the twisted alignment direction of the liquid crystal molecules. Therefore, the linearly polarized light is substantially parallel to the major axis of the liquid crystal molecules near the opposed substrate **200** when reaching the polarizer **220**. Because the polarization direction of this linearly polarized light is substantially parallel to the polarization axis of the polarizer **220**, the transmissive display is in bright display.

[0061] In the reflective section **60R**, in response to application of the ON voltage, the liquid crystal molecules are aligned in a direction that is substantially perpendicular to the surface of each of the first electrode **120** and the third electrode **218**. Light incident from the outside adjacent to the opposed substrate **200** follows the same similar path (optical path) as in the dark display and then returns to the polarizer **220**, and, because of the alignment state described above, birefringence of the liquid crystal **300** have little effect thereon. Therefore, the externally input light that has returned to the polarizer **220** is linearly polarized light that is substantially parallel to the polarization axis of the polarizer **220** as a result of being subjected to the rotation operation of the retardation film **216** twice, i.e., going and returning, in total. Therefore, the linearly polarized light passes through the polarizer **220**. As a result, the reflective display is in bright display.

[0062] In the foregoing, how the dark display and the bright display are performed is described. The luminance level between the dark display and the bright display, so-called halftones, can be controlled by control of the magnitude of the applied voltage.

[0063] According to the above described structure, since the transmissive section **60T** is of the FFS type and the

reflective section 60R is of the ECB type, excellent display can be obtained in both the reflective display and the transmissive display. With a structure in which a retardation layer is disposed within a reflective portion, it is not necessary to attach another retardation film to the outer surface. Therefore, a liquid crystal panel of this type can be thinner than a transmissive liquid crystal panel of other types. The retardation film 216 also serves as a layer for reducing the cell gap in the reflective section 60R smaller than that in the transmissive section 60T. This can reduce manufacturing steps.

[0064] Since the reflective section 60R of the ECB type, which has higher reflectance than that in the FFS type, the reflective display can exhibit higher luminance, compared with when both the transmissive section 60T and the reflective section 60R are of the FFS type.

[0065] Since the reflective section 60R is not of the FFS type, even when the planarization layer 116 has asperities, it is not necessary to form the second electrode 124 having the slit 126 on these asperities. Therefore, there are no patterning defects caused by a slit on the asperities. Therefore, excellent reflective display can be obtained. In the transmissive display, the FFS type offers a wide viewing angle and a high contrast.

[0066] In typical FFS display devices, an ITO film is often provided to the outer surface of an opposed substrate in order to shield an external electric field. However, according to the above described structure, it is not necessary to have an external shielding structure. This is because the third electrode 218 of the opposed substrate 200 carries out the shielding function. Even when not all areas of the opposed substrate 200 are covered by the third electrode 218, the third electrode 218 can perform the shielding function.

[0067] Since the retardation film 216 is not provided to the transmissive section 60T, unlike when the retardation film 216 is externally attached without making a distinction between the transmissive section 60T and the reflective section 60R, the FFS transmissive display ensures a wide viewing angle and high contrast.

[0068] The presence of the retardation film 216 reduces the cell gap in the reflective section 60R smaller than that in the transmissive section 60T (so-called multi-gap construction). For example, the cell gap in the transmissive section 60T is approximately 3.0 μm , and that in the reflective section 60R is approximately 1.4 μm . As a result, the cell gap in each of the transmissive section 60T and the reflective section 60R can be adjusted without additional top coating layer. For example, the cell gap in the reflective section 60R can be adjusted to a value suitable for the ECB type.

[0069] In the foregoing, the transmissive display is of the FFS type. However, the transmissive display may be of the IPS type. In the case of the IPS type, as illustrated in FIG. 3, the first electrode 120 and the second electrode 124 are

disposed on the planarization layer 116, i.e., on the same layer. FIG. 3 illustrates a state in which the entire pixels are in bright display.

[0070] The normally white mode can also be realized by arranging the polarizers 128 and 220 such that their respective polarization axes are substantially parallel to each other.

What is claimed is:

1. A liquid crystal display device comprising, in sequence: a first substrate; a liquid crystal layer; and a second substrate,

wherein the first substrate, the liquid crystal layer, and the second substrate are disposed in a subpixel having a transmissive portion for performing transmissive display and a reflective portion for performing reflective display,

the first substrate includes a first electrode and a second electrode,

the second substrate includes a third electrode,

the first electrode and the second electrode are disposed in the transmissive portion and at least the first electrode and the third electrode are disposed in the reflective portion, and

alignment of the liquid crystal layer is controlled by an electric field occurring between the first electrode and the second electrode in the transmissive portion and by an electric field occurring between the first electrode and the third electrode in the reflective portion.

2. The liquid crystal display device according to claim 1, further comprising:

a retardation layer incorporated in the reflective portion.

3. The liquid crystal display device according to claim 2, wherein the retardation layer is included in the second substrate.

4. The liquid crystal display device according to claim 3, wherein the retardation layer is a half-wave plate.

5. The liquid crystal display device according to claim 2, wherein, due to the retardation layer, a cell gap in the reflective portion is thinner than a cell gap in the transmissive portion.

6. The liquid crystal display device according to claim 1, wherein a cell gap in the reflective portion is thinner than a cell gap in the transmissive portion.

7. The liquid crystal display device according to claim 1, wherein the first electrode, an insulating layer, and the second electrode are stacked in the first substrate in this sequence, and

the second electrode has a slit in an area facing the first electrode.

8. The liquid crystal display device according to claim 1, wherein the same electric potential is applied to the second electrode and the third electrode.

* * * * *

专利名称(译)	液晶显示装置		
公开(公告)号	US20080068543A1	公开(公告)日	2008-03-20
申请号	US11/902036	申请日	2007-09-18
[标]申请(专利权)人(译)	爱普生映像元器件有限公司		
申请(专利权)人(译)	爱普生影像设备公司		
当前申请(专利权)人(译)	爱普生影像设备公司		
[标]发明人	MITSUI MASASHI KOMA NORIO		
发明人	MITSUI, MASASHI KOMA, NORIO		
IPC分类号	G02F1/1335		
CPC分类号	G02F1/133753 G02F2203/09 G02F2001/134381 G02F1/134309		
优先权	2006252658 2006-09-19 JP		
其他公开文献	US8018553		
外部链接	Espacenet USPTO		

摘要(译)

液晶显示装置依次包括第一基板，液晶层和第二基板。第一基板，液晶层和第二基板设置在子像素中，子像素具有用于执行透射显示的透射部分和用于执行反射显示的反射部分。第一基板包括第一电极和第二电极。第二基板包括第三电极。第一电极和第二电极设置在透射部分中，并且至少第一电极和第三电极设置在反射部分中。通过在透射部分中的第一电极和第二电极之间发生的电场以及在反射部分中在第一电极和第三电极之间发生的电场来控制液晶层的对准。

