

FIG. 1
RELATED ART

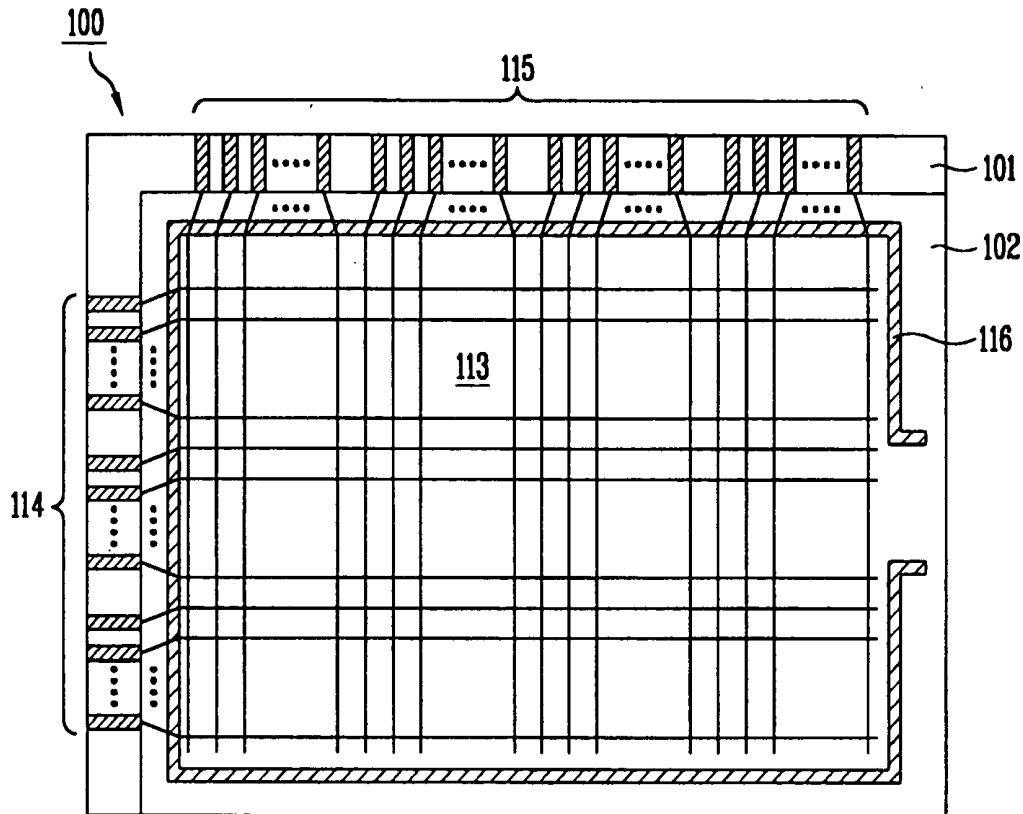

FIG. 2A
RELATED ART

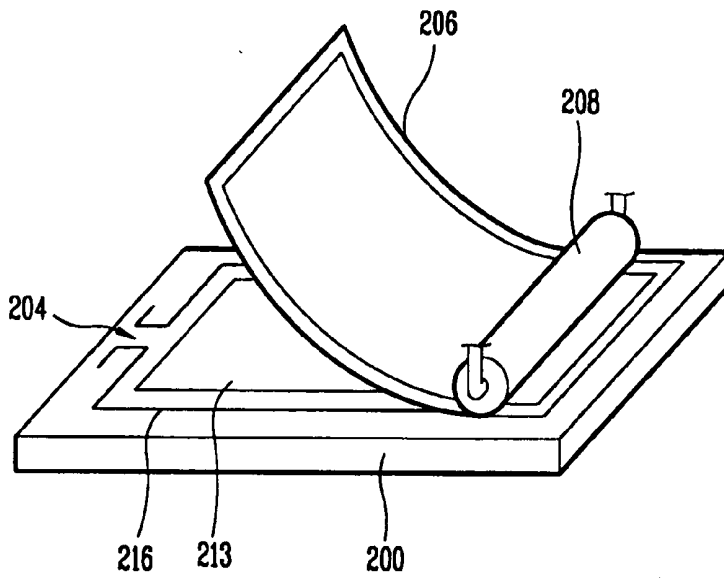

FIG. 2B
RELATED ART

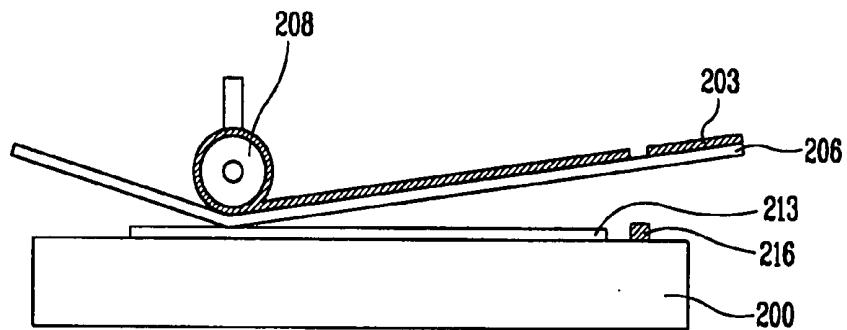

FIG. 3
RELATED ART

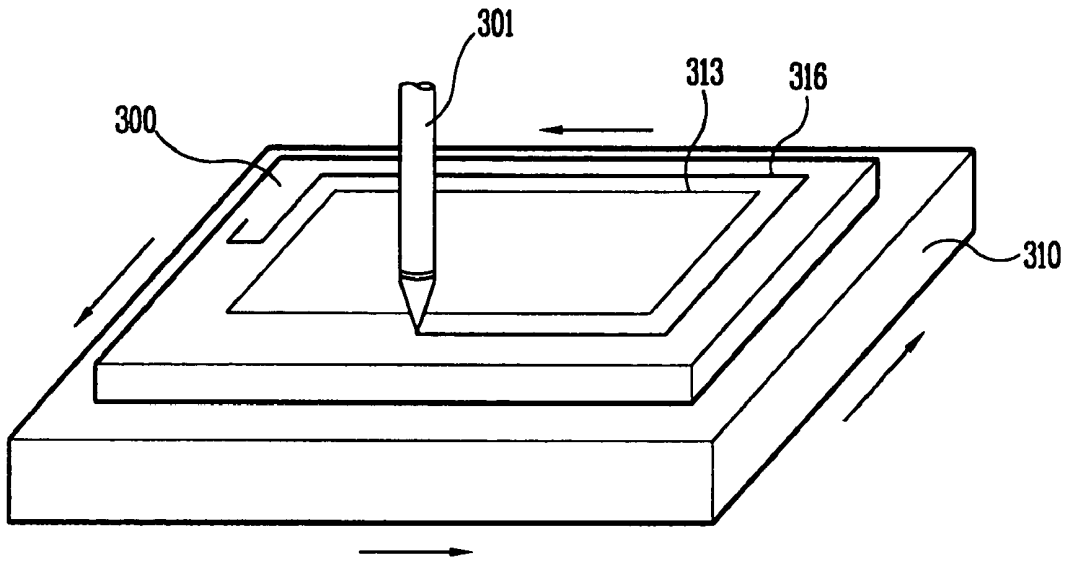

FIG. 4
RELATED ART

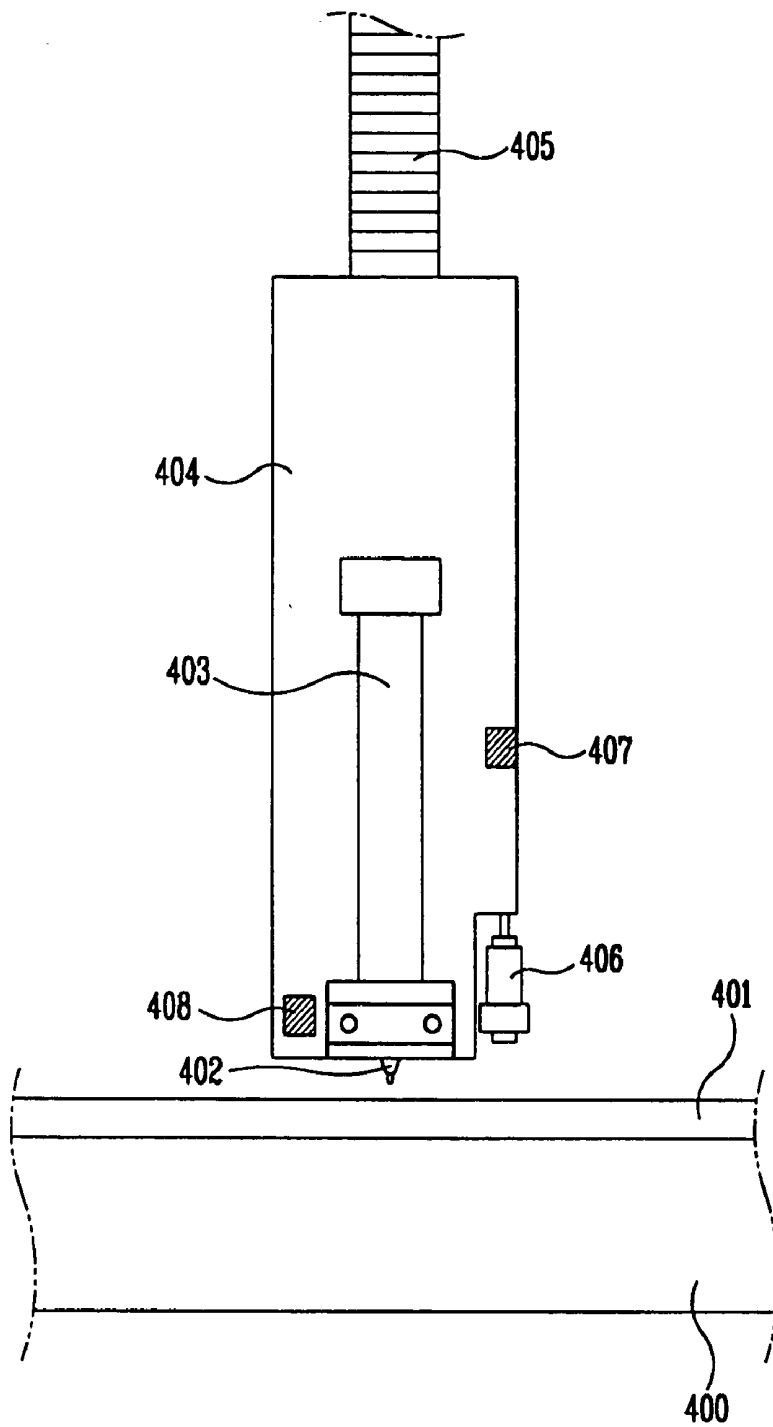

FIG. 5

RELATED ART

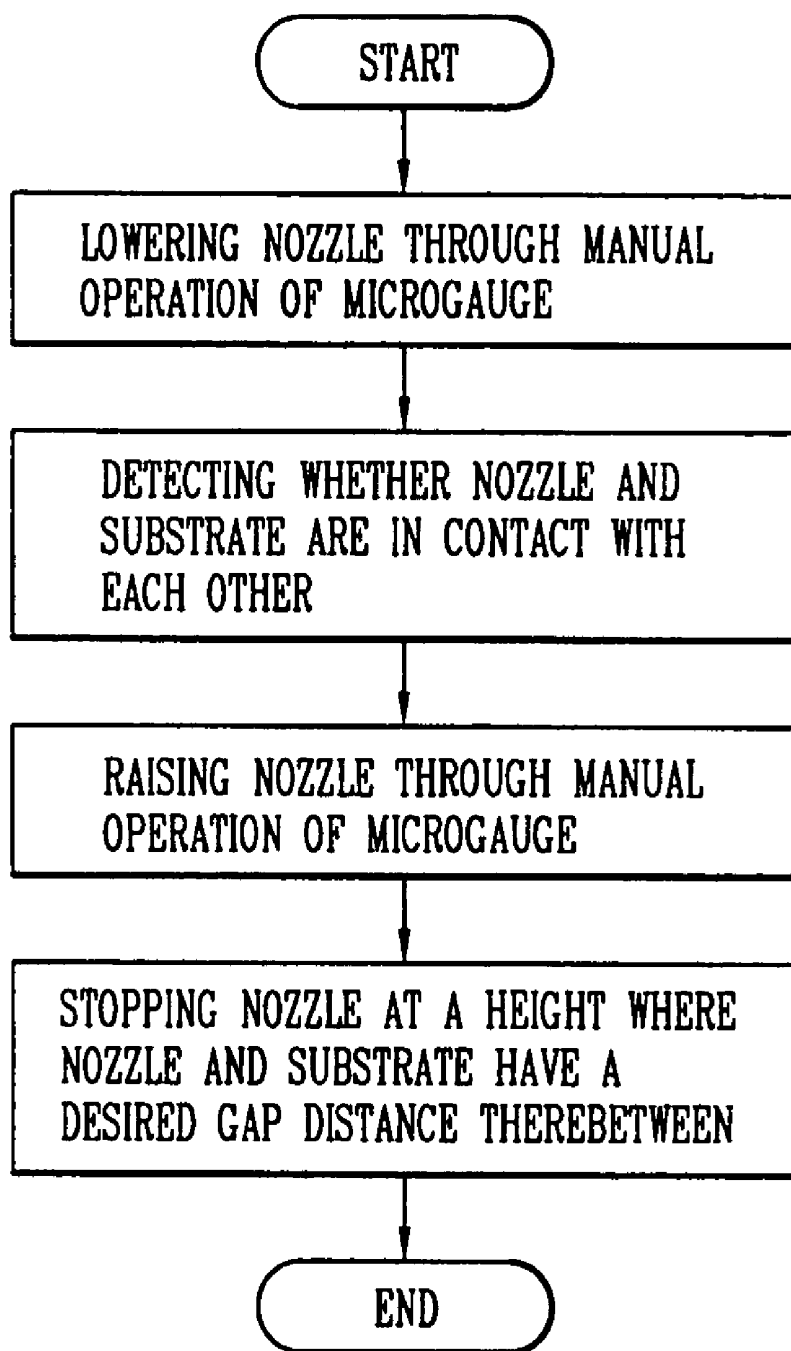

FIG. 6

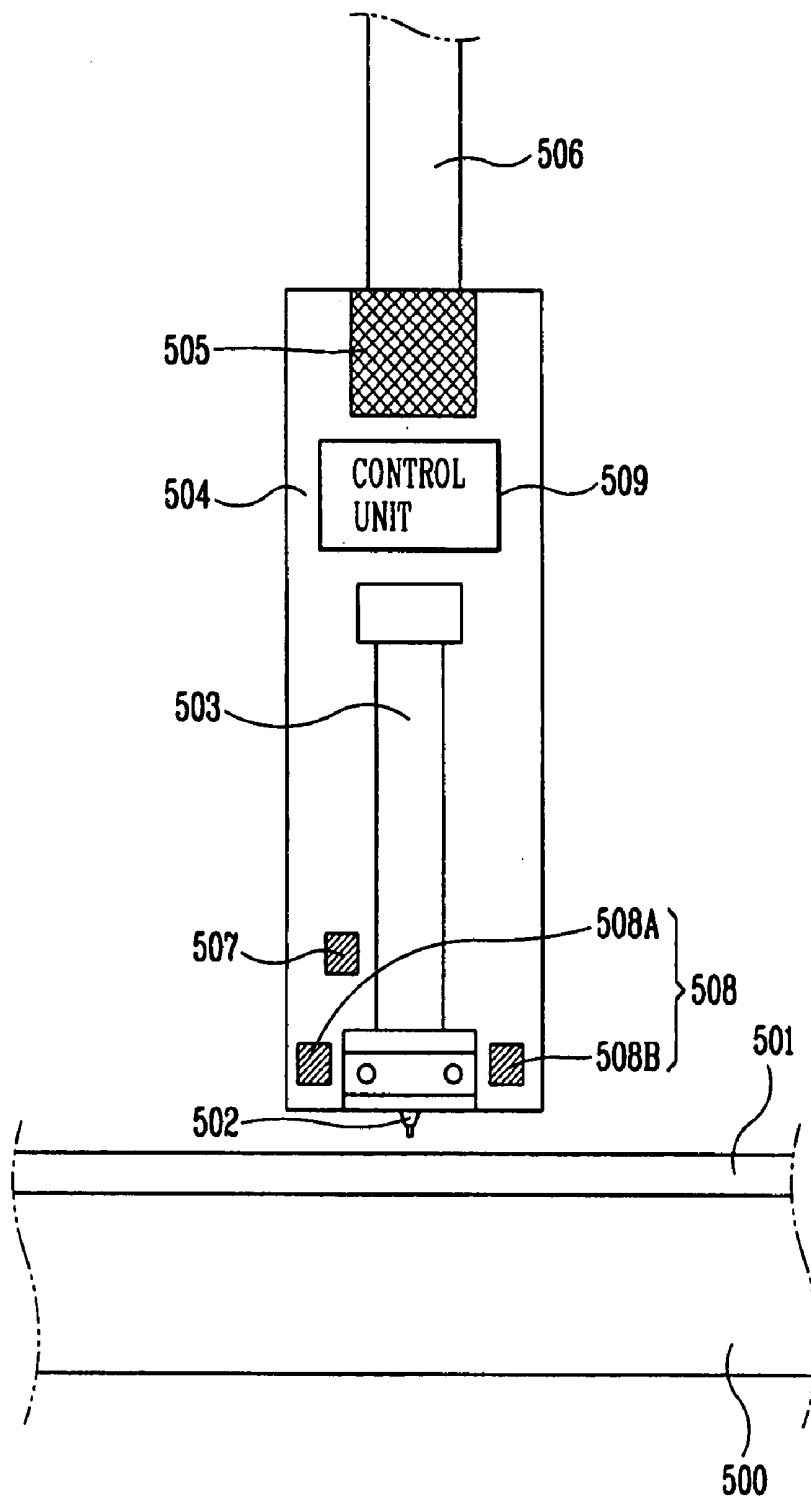

FIG. 7

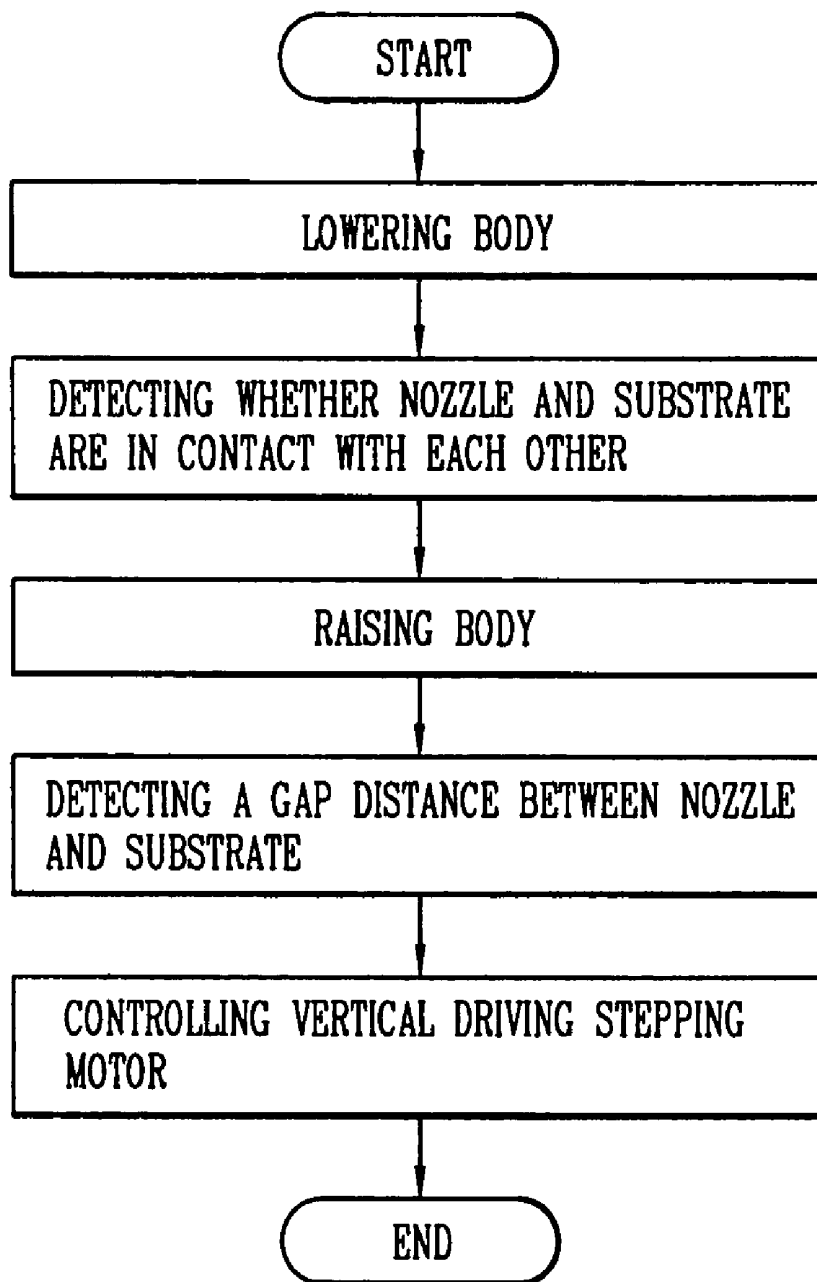

FIG. 8

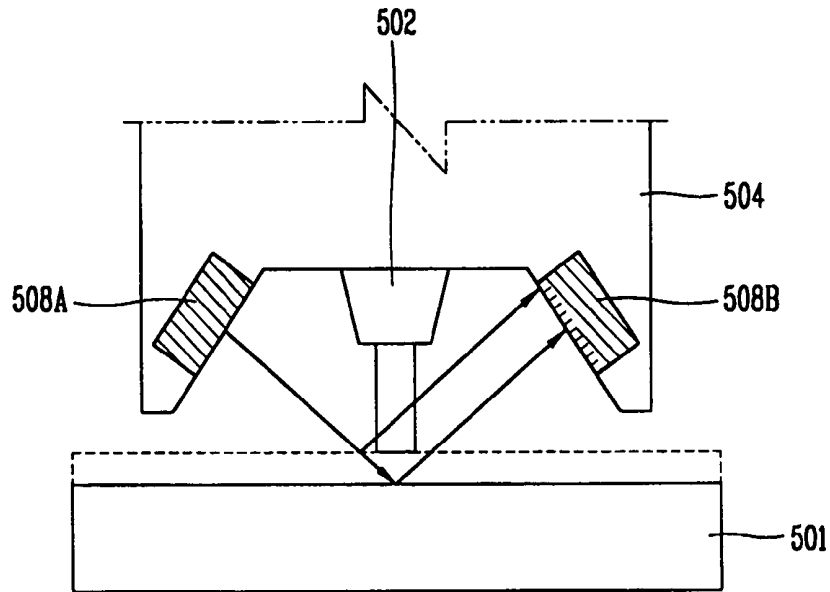
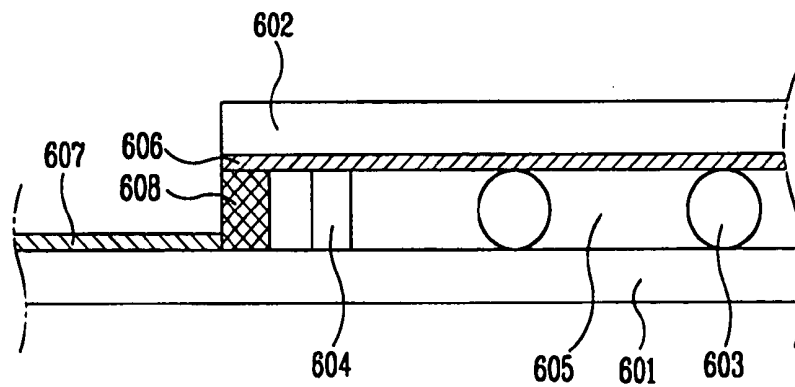

FIG. 9



**DISPENSER FOR LIQUID CRYSTAL DISPLAY
PANEL AND METHOD FOR CONTROLLING GAP
BETWEEN SUBSTRATE AND NOZZLE USING
THE SAME**

[0001] This application claims the benefit of the Korean Application No. P2002-081439 filed on Dec. 18, 2002, which is hereby incorporated by reference.

BACKGROUND OF THE INVENTION

[0002] 1. Field of the Invention

[0003] The present invention relates to a dispenser for a liquid crystal display panel and a method for controlling a gap distance between a nozzle and a substrate when using the dispenser, and more particularly, to a dispenser for a liquid crystal display panel and a method for controlling a gap distance between a nozzle and a substrate when using the dispenser to control a gap distance between the substrate, where a liquid crystal display panel is formed, and the nozzle.

[0004] 2. Discussion of the Related Art

[0005] In general, a liquid crystal display device is a display device where data signals according to picture information are individually supplied to liquid crystal cells arranged in a matrix form. Light transmittance of the liquid crystal cells is controlled in accordance with the data signals to display a desired picture. The liquid crystal display device includes a liquid crystal display panel where the liquid crystal cells are arranged in a matrix form, and a driver integrated circuit (IC) for driving the liquid crystal cells. The liquid crystal display panel includes a color filter substrate and a thin film transistor array substrate attached to each other. The liquid crystal display panel further includes a liquid crystal layer between the color filter substrate and the thin film transistor array substrate.

[0006] Data lines and gate lines are formed on the thin film transistor array substrate of the liquid crystal display panel and cross each other at right angles so as to define liquid crystal cells. The data lines transmit a data signal supplied from the data driver integrated circuit to the liquid crystal cells. The gate lines transmit a scan signal supplied from the gate driver integrated circuit to the liquid crystal cells. At an end portion of each of the data lines and the gate lines, a data pad and a gate pad are respectively provided in which data signals and scan signals are respectively applied from the data driver integrated circuit and the gate driver integrated circuit. The gate driver integrated circuit sequentially supplies a scan signal to the gate lines so that the liquid crystal cells arranged in a matrix form can be sequentially selected line by line while a data signal is supplied to the selected line of the liquid crystal cells from the data driver integrated circuit.

[0007] A common electrode and a pixel electrode are respectively formed on the inner side of the color filter substrate and the thin film transistor array substrate for applying an electric field to the liquid crystal layer of a liquid crystal cell. More particularly, a pixel electrode is respectively formed in each liquid crystal cell on the thin film transistor array substrate, while the common electrode is integrally formed across the entire surface of the color filter substrate. Therefore, by controlling a voltage applied to the pixel electrode while a voltage is applied to the common

electrode, light transmittance of the liquid crystal cells can be individually controlled. To control the voltage applied to the pixel electrode by liquid crystal cells, a thin film transistor is formed in each liquid crystal cell and used as a switching device.

[0008] FIG. 1 is a plane view of the unit liquid crystal display panel formed by a thin film transistor array substrate and a color filter substrate according to the related art. As shown in FIG. 1, the liquid crystal display panel 100 includes an image display part 113 where the liquid crystal cells are arranged in a matrix form, a gate pad part 114 connected to the gate lines of the image display part 113, and a data pad part 115 connected to the data lines of the image display part 113. The gate pad part 114 and the data pad part 115 are formed along an edge region of the thin film transistor array substrate 101, which does not overlap with the color filter substrate 102. The gate pad part 114 supplies a scan signal from the gate driver integrated circuit to the gate lines of the image display part 113, and the data pad part 115 supplies image information from the data driver integrated circuit to the data lines of the image display part 113.

[0009] Data lines to which image information is applied and gate lines to which a scan signal is applied are provided on the thin film transistor array substrate 101. The data lines and the gate lines cross each other. Additionally, a thin film transistor for switching the liquid crystal cells is provided at each crossing of the data lines and the gate lines. A pixel electrode for driving the liquid crystal cells is connected to the thin film transistor and provided on the thin film transistor array substrate 101. A passivation film for protecting the pixel electrode and the thin film transistor is formed at the entire surface of the thin film transistor array substrate 101.

[0010] Color filters are provided on the color filter substrate 102 for each cell region. The color filters are separated by a black matrix. A common transparent electrode is also provided on the color filter substrate 102.

[0011] A cell gap is formed by a spacer between the thin film transistor array substrate 101 and the color filter substrate 102. A seal pattern 116 is formed along an outer edge of the image display part 113. The thin film transistor array substrate 101 and the color filter substrate 102 are attached by the seal pattern 116 to thereby form a unit liquid crystal display panel.

[0012] In fabricating the unit liquid crystal display panel, a method for simultaneously forming unit liquid crystal display panels on a large-scale mother substrate is generally used. Thus, a process is required for separating the unit liquid crystal display panels from the large-scale mother substrate. For example, a cutting process can be used on the mother substrate to separate the plurality of unit liquid crystal display panels formed thereon.

[0013] The seal pattern 116, as discussed above, has an opening. After the unit liquid crystal display panel is separated from the large-scale mother substrate, liquid crystal is injected through a liquid crystal injection opening to form a liquid crystal layer at the cell-gap, which separates the thin film transistor array substrate 101 and the color filter substrate 102. Then, the liquid crystal injection opening is sealed.

[0014] As mentioned above, the following steps are required to fabricate the unit liquid crystal display panel: the

thin film transistor array substrate **101** and the color filter substrate **102** are separately fabricated on the first and second mother substrates, the first and second mother substrates are attached in such a manner that a uniform cell-gap is maintained therebetween, the attached first and second mother substrates are cut into unit panels, and then liquid crystal is injected to the cell-gap between the thin film transistor array substrate **101** and the color filter substrate **102**. In particular, the process of forming the seal pattern **116** along an outer edge of the image display part **113** is required to attach the thin film transistor array substrate **101** and the color filter substrate **102**. The related art process of forming a seal pattern will now be described.

[0015] FIGS. 2A and 2B illustrate a screen printing method to form a seal pattern. As shown in FIGS. 2A and 2B, there is provided a screen mask **206** patterned so that a of seal pattern forming region is exposed. A rubber squeegee **208** is used to selectively supply a sealant **203** to the substrate **200** through the screen mask **206** so as to simultaneously form a seal pattern **216**. The seal pattern **216** formed on the substrate **200** creates a gap in which liquid crystal layer is later injected and prevent leakage of the liquid crystal. Thus, the seal pattern **216** is formed along each outer edge of the image display part **213** of the substrate **200** and liquid crystal injection opening **204** is formed for the seal pattern **216**.

[0016] The screen printing method includes: applying the sealant **203** on the screen mask **206** with the seal pattern forming region patterned thereon, forming the seal pattern **216** on the substrate **200** through printing with the rubber squeegee **208**; and evaporating a solvent contained in the seal pattern **216** and leveling the pattern. The screen printing method is widely used because it is an easy process. However, the screen printing method is disadvantageous in that sealant **203** is wasted because a lot of sealant is discarded after the squeegee **208** is drawn across the screen mask to form the seal pattern **216**. In addition, the screen printing method has a problem in that rubbing of an orientation film (not shown) formed on the substrate **200** can incur defects when the screen mask **206** and the substrate **200** come into contact with each other. These defects will degrade picture quality of the liquid crystal display device.

[0017] To overcome the shortcomings of the screen printing method, a seal dispensing method has been proposed. FIG. 3 is an exemplary view of a related art dispensing method for forming a seal pattern. As shown in FIG. 3, while a table **310** with the substrate **300** loaded thereon is moved in forward/backward and left/right directions, a seal pattern **316** is formed along an outer edge of image display part **313** on the substrate **300** by applying a predetermined pressure to syringe **301** filled with a sealant. The seal pattern **316** is sequentially formed for the image display part **313**.

[0018] In the seal dispensing method, since the sealant is selectively supplied to the region where the seal pattern **316** is to be formed, sealant waste is prevented. In addition, the syringe **301** does not contact the orientation film (not shown) of the image display part **313** of the substrate **300** so that the rubbed orientation film will not be damaged. Thus, picture quality of the liquid crystal display device will be maintained.

[0019] In the case of forming the seal pattern **316** on the substrate **300** by using the syringe **301**, a technique for

precisely controlling a gap distance between the substrate **300** and the syringe **301** is required. That is, if the substrate **300** and the syringe **301** are too close compared to a desired gap distance, the seal pattern **316** formed on the substrate **300** is wide and thin. If, however, the substrate **300** and the syringe **301** are separated too much compared to the desired gap distance, the seal pattern **316** formed on the substrate **300** becomes narrow and may become noncontiguous, which causes a defect in the liquid crystal display device.

[0020] If the sealant in the syringe **301** is completely used up while forming a seal pattern, the seal pattern **316** cannot be completely formed. Thus, a syringe **301** should be replaced with another syringe **301** filled with the sealant before it is completely used up. At this time, however, the gap distance between the substrate **300** and the syringe **301** varies depending on the syringe **301** in use. Thus, the gap distance between the substrate **300** and a syringe **301** should be reset and/or checked every time a syringe **301** is replaced with a new syringe. Replacement of the syringe **301** is frequently done during actual manufacturing of products. Therefore, a technique for setting or checking the gap distance between the substrate **300** and the syringe **301** within a short time is preferable.

[0021] In the related art, a manual operation method has been adopted to control the gap distance between the substrate **300** and the syringe **301**, which will now be described in detail. FIG. 4 is an exemplary view showing a seal dispenser of a liquid crystal display panel in accordance with the related art. As shown in FIG. 4, a seal dispenser includes a syringe **403** with a nozzle **402** at one end thereof for supplying a sealant onto a substrate **401** that is loaded onto a table **400**, a body **404** for mounting the syringe **403** above the substrate **401**, a vertical driving servo motor **405** for moving the body **404** in a vertical direction; a microgauge **406** for turning the vertical driving servo motor **405** via manual operation, a first sensor **407** for detecting whether the substrate **401** and the nozzle **402** are in contact with each other; and a second sensor **408** for detecting a gap distance between the substrate **401** and the nozzle **402**.

[0022] FIG. 5 is a flow chart of a method according to the related art for controlling a gap distance between the nozzle and the substrate by using the seal dispenser of the liquid crystal display panel. As shown in FIG. 5, the method according to the related art for controlling a gap distance between the nozzle and the substrate by using the seal dispenser of the liquid crystal display panel includes lowering the nozzle **402** by manually manipulating the microgauge **406**; detecting whether the nozzle **402** and the substrate **401** are in contact with each other; raising the nozzle **402** by manually manipulating the microgauge **406**; and stopping the nozzle at the gap distance between the nozzle **402** and the substrate **401**.

[0023] The related art of the seal dispenser of the liquid crystal display panel and the method for controlling a gap distance between the nozzle and the substrate using the dispenser will now be described in more detail. First, when the substrate **401** is loaded on the table **400**, a user turns the vertical driving servo motor **405** by manually manipulating the microgauge **406** to thereby lower the syringe **403** mounted in the body **404**. At this time, the user detects whether the nozzle **402** provided at an end portion of the syringe **403** and the substrate **401** loaded on the table **400** are

in contact with each other through monitoring of a value measured by the first sensor 407.

[0024] When the substrate 401 and the nozzle 402 are detected to be in contact with each other by the first sensor 407, the user turns the vertical driving servo motor 405 by manually manipulating the microgauge 406, thereby raising the syringe 403 mounted in the body 404. At this time, the user detects whether the gap distance between the substrate 401 and the nozzle 402 reaches a desired value through monitoring of a value measured by the second sensor 408 and stops manipulating the microgauge 406 when the value measured by the second sensor 408 reaches a desired value.

[0025] The related art of the seal dispenser of the liquid crystal display panel and the method for controlling a gap distance between the nozzle and the substrate have the following problems. First, since the user controls the gap distance between the substrate 401 and the nozzle 402 by manually manipulating the microgauge 406, reliability and consistency are low, which increases the defective occurrence rate in the manufactured liquid crystal display panels. In addition, even a skilled user requires a lot of time to set the gap distance between the substrate 401 and the nozzle 402 precisely, which degrades productivity. Furthermore, since the gap distance is set by the user's manual operation, a strong and constant concentration, which quickly tires users, is required for users to maintain a good process pace.

SUMMARY OF THE INVENTION

[0026] Accordingly, the present invention is directed to a dispenser for a liquid crystal display panel and method for controlling gap between substrate and nozzle using the same that substantially obviates one or more of the problems due to limitations and disadvantages of the related art.

[0027] An object of the present invention is to provide a dispenser for a liquid crystal display panel and a method for controlling a gap distance between a nozzle and a substrate using the same that are capable of automatically controlling a gap distance between a nozzle provided at a dispenser and a substrate.

[0028] To achieve these and other advantages and in accordance with the purpose of the present invention, as embodied and broadly described herein, there is provided a dispenser for a liquid crystal display panel including: a syringe having a nozzle provided at an end thereof; a body in which the syringe is mounted; a vertical driving stepping motor for moving the body in a vertical direction; a first sensor for detecting whether the nozzle of the syringe is in contact with a substrate, a second sensor for detecting a gap distance between the nozzle and the substrate; and a main unit for controlling the vertical driving stepping motor in response to an output from the second sensor to obtain a desired gap distance between the nozzle and the substrate.

[0029] In another aspect, there is also provided a method for controlling a gap between a nozzle and a substrate using a dispenser for a liquid crystal display panel including: lowering a body with a syringe mounted therein using a vertical driving stepping motor; detecting whether a nozzle of the syringe is in contact with a substrate; raising the body; detecting a gap distance between the nozzle and the substrate; and controlling the vertical driving stepping motor so that a desired gap distance is obtained between the nozzle and the substrate.

[0030] It is to be understood that both the foregoing general description and the following detailed description are exemplary and explanatory and are intended to provide further explanation of the invention as claimed.

BRIEF DESCRIPTION OF THE DRAWINGS

[0031] The accompanying drawings, which are included to provide a further understanding of the invention and are incorporated in and constitute a part of this specification, illustrate embodiments of the invention and together with the description serve to explain the principles of the invention.

[0032] FIG. 1 is a plane view of the unit liquid crystal panel formed by attaching a thin film transistor array substrate and a color filter substrate according to the related art.

[0033] FIGS. 2A and 2B illustrate formation of a seal pattern through a screen printing method in accordance with the related art.

[0034] FIG. 3 illustrates formation of a seal pattern through a seal dispensing method in accordance with the related art.

[0035] FIG. 4 illustrates a seal dispenser of a liquid crystal display panel in accordance with the related art.

[0036] FIG. 5 is a flow chart of a method according to the related art for controlling a gap distance between a nozzle and a substrate using the seal dispenser of FIG. 4.

[0037] FIG. 6 illustrates a dispenser for a liquid crystal display panel in accordance with an embodiment of the present invention.

[0038] FIG. 7 is a flow chart of a method in accordance with an embodiment of the present invention for controlling a gap distance between a nozzle and a substrate using the dispenser of FIG. 6.

[0039] FIG. 8 shows a detailed construction of a second sensor in FIG. 6.

[0040] FIG. 9 is a schematic view showing a sectional structure of one edge of the liquid crystal display panel.

DETAILED DESCRIPTION OF THE ILLUSTRATED EMBODIMENTS

[0041] Reference will now be made in detail to the illustrated embodiments of the present invention, examples of which are illustrated in the accompanying drawings.

[0042] FIG. 6 illustrates a dispenser for a liquid crystal display panel in accordance with the present invention. As shown in FIG. 6, a dispenser for a liquid crystal display panel in accordance with the present invention includes a table 500 for supporting a substrate 501, a syringe 503 with a nozzle 502 provided at an end portion thereof for supplying a sealant onto the substrate 501, a body 504 in which the syringe 503 is mounted, a vertical driving stepping motor 505 for moving the body 504 along a vertical shaft 506 in a vertical direction, a first sensor 507 for detecting whether the nozzle 502 of the syringe 503 is in contact with the substrate 501, a second sensor 508 for detecting a gap distance between the nozzle 502 and the substrate 501 and a control unit 509 for controlling the vertical driving stepping motor 505. The control unit 509 controls the vertical driving

stepping motor **505** based upon signals from the first sensor **507** and the second sensor **508**. The control unit **509** can be located in the body **504**, on an external surface of the body **504**, integrated into one of the sensors, integrated into both of the sensors or at a location completely separate from the body **504**.

[0043] FIG. 7 is a flow chart of a method in accordance with an embodiment of the present invention for controlling a gap distance between a nozzle and a substrate using the dispenser of FIG. 6. As shown in FIG. 7, a method for controlling a gap distance between a nozzle and a substrate using the dispenser includes lowering the body **504** having the syringe **503** mounted therein using the vertical driving stepping motor **505**; detecting whether the nozzle **502** of the syringe **503** is in contact with the substrate **501**; raising body **504**; detecting a gap distance between the nozzle **502** and the substrate **501**; and controlling the vertical driving stepping motor **505** so that the gap distance between the nozzle **502** and the substrate **501** obtains a desired gap distance.

[0044] The dispenser for a liquid crystal display panel and the method for controlling a gap distance between the nozzle and the substrate using the dispenser will now be described in detail. First, the substrate **501** is loaded onto the table **500**. The vertical driving stepping motor **505** is then driven to lower the body **504** having the syringe **503** mounted therein. After the body **504** is lowered, the first sensor **507** is used to detect whether the nozzle **502** provided at an end portion of the syringe **503** is in contact with the substrate **501**.

[0045] If the table **500** is metallic, a magnetic sensor, for example, can be used as the first sensor **507**. The magnetic sensor in the body **504** sends a signal to the control unit **509** that changes as the body **504** is lowered by the vertical driving stepping motor **505** toward the table **500**. When the nozzle **502** is in contact with the substrate **501**, the lowering of the body **504** stops so that the electric signal stops changing. The control unit **509** recognizes an absence of change in the electric signal as the nozzle **502** being in contact with the substrate **501**. When the control unit **509** recognizes that lowering of the body **504** has stopped, the control unit **509** stops the vertical driving stepping motor **505**.

[0046] After the control unit **509** has controlled the vertical driving stepping motor **505** to stop the lowering of the body **504**, the control unit **509** controls the vertical driving stepping motor **505** to raise the body **504**. A second sensor **508** is used to detect the gap distance between the nozzle **502** and the substrate **501**. Based upon an output from the second sensor **508**, the control unit **509** controls the vertical driving stepping motor **505** to raise the body **504** so that a desired gap distance can be obtained between the nozzle **502** and the substrate **501**. Subsequently, the control unit **509** controls the vertical driving stepping motor **505** to raise and lower the body **504** so that a desired gap distance can be maintained between the nozzle **502** and the substrate **501**. A laser displacement sensor, which has an accuracy, for example, of 200 μm can be adopted as the second sensor **508**.

[0047] FIG. 8 shows a detailed construction of a second sensor of FIG. 6 in accordance with an embodiment of the present invention. As shown in FIG. 8, the laser displacement sensor is provided near the nozzle **502** of the body **504**, and includes a light emitting unit **508A** irradiating laser on the surface of the substrate **501** and a light receiving unit

508B on which the laser irradiated from the light emitting unit **508A** is incident after being reflected from the substrate **501**. The light receiving unit **508B** is constructed to detect a gap distance between the nozzle **502** and the substrate **501** according to a position on the surface of the light receiving unit **508B** at which the laser is incident. For example, if the gap distance between the nozzle **502** and the substrate **501** is to be about as 40 μm , the light receiving unit **508B** is set such that the laser reflected from the substrate **501** is made incident at the center of the light receiving unit **508B**. Accordingly, when the nozzle **502** is too close to the substrate **501**, the laser reflected from the substrate **501** is made incident at an upper end of the light receiving unit **508B**. Then, the vertical driving stepping motor **505** is controlled by the control unit **509** to raise the body **504** so that the laser reflected from the substrate **501** may be made incident at the center of the light receiving unit **508B**. On the other hand, if the nozzle **502** is too far away from the substrate **501** so as to cause the laser reflected from the substrate **501** to be incident at a lower end of the light receiving unit **508B**, the control unit **509** lowers the body **504** so that the laser reflected from the substrate **501** may be made incident at the center of the light receiving unit **508B**. Thus, the gap distance between the nozzle **502** and the substrate **501** can be consistently set and maintained at about 40 μm .

[0048] After the gap distance between the substrate **501** and the nozzle **502** is controlled to be at a desired gap, either the table **500**, on which the substrate **501** has been loaded, or the body **504**, in which the syringe **503** mounted therein, is horizontally moved to change position while the sealant is being applied to the substrate **501** to form a seal pattern on the substrate **501**. In the case that the body **504** having the syringe **503** mounted therein is moved, a foreign material may be generated due to the movement of the dispenser that can be adsorbed into the substrate **501**. Thus, the table **500** with the substrate **501** loaded thereon may be moved in forward/backward and left/right directions to form the seal pattern. The control unit **509** can maintain the desired gap distance as the table is moved base upon an output from the second sensor **508**.

[0049] According to the dispenser for a liquid crystal display panel and the method for controlling the gap between the nozzle and the substrate in accordance with the present invention, the laser is irradiated for reception by the second sensor while the seal pattern is being formed by horizontally moving the table **500** with the substrate **501** loaded thereon in the forward/backward and left/right directions. Thus, the gap distance between the nozzle **502** and the substrate **501** can be controlled or maintained on a real time basis. Even if there is a small uneven portion in the surface of the substrate **501**, the seal pattern can still be formed with a uniform height and width because of the real time control of the gap distance between the nozzle **502** and the substrate **501**.

[0050] The method for controlling a gap distance between the substrate and the nozzle in accordance with the present invention is started with a driving instruction being input from a user through an input unit such as a touch panel or a keyboard. In the alternative, the process can start when a substrate is detected via other types of input devices. The vertical driving stepping motor **505** automatically lowers the body **504** after the input is received. Then, the contact of the

nozzle **502** to the substrate **501** is detected by the first sensor **507**. The body **504** is raised by the vertical driving stepping motor **505** and is controlled to be maintained at a predetermined distance from the substrate **501** based upon an output from the second sensor **508** such that the gap distance between the substrate **501** and the nozzle **502** is consistently and/or constantly controlled to be at a desired gap distance.

[**0051**] Degradation of picture quality and yield of the liquid crystal display panel due to a defective seal pattern can be prevented by using the dispenser for a liquid crystal display panel and the method for controlling a gap distance between the substrate and the nozzle in accordance with the present invention. In addition, even an unskilled user can precisely set and control the gap distance between the substrate **501** and the nozzle **502** in a short time period so that productivity is improved.

[**0052**] The shape of the seal pattern formed according to the present invention may be varied depending on the method of forming a liquid crystal layer. The method for forming the liquid crystal layer may be divided into a vacuum injection method and a dropping method, which will now be described in detail. First, the vacuum injection method begins with a unit liquid crystal display panel having a liquid crystal injection opening being separated from a large-scale mother substrate and positioned in a container filled with liquid crystal in a vacuum chamber. Then, liquid crystal is injected into the liquid crystal display panel according to a pressure difference between an inner side and an outer side of the liquid crystal display panel by varying a vacuum degree. After the liquid crystal is filled into the liquid crystal display panel, the liquid crystal injection opening is sealed to form the liquid crystal layer of the liquid crystal display panel. The liquid crystal injection opening in the vacuum injection method is defined as a region opened at each side of the seal patterns. Thus, in the case of forming a liquid crystal layer at the liquid crystal display panel through the vacuum injection method, the seal patterns are formed with each opened portion to function as a liquid crystal injection opening.

[**0053**] The vacuum injection method has the following problems. First, it takes a long time to fill liquid crystal into the liquid crystal display panel using the vacuum injection method. In general, the attached liquid crystal display panel with an area of several hundreds cm^2 has only a gap of a few μm . Thus, even with the vacuum injection method, which uses the pressure difference, the injection quantity of liquid crystal by unit time is naturally quite small. For instance, in the case of fabricating a liquid crystal display panel of about 15 inches, 8 hours are required to fill it with liquid crystal. Such a long time taken for fabrication of the liquid crystal display panel degrades productivity. As the size of liquid crystal display panel increase, the time required for filling liquid increases such that productivity further degrades. Therefore, the vacuum injection method does not readily cope with the fabrication of large-scale liquid crystal display panels.

[**0054**] Second, a lot of liquid crystal is consumed using the vacuum injection method. In general, the actual injected quantity of liquid crystal is very small compared to the amount of liquid crystal filled into the container. Liquid crystal degrades when exposed to air or to a specific gas. Thus, a large amount of liquid crystal remaining after filling

has to be discarded, which increases the unit price of the liquid crystal display device so that price competitiveness of the product is weakened.

[**0055**] In order to overcome such problems of the vacuum injection method, the dropping method has been recently adopted. The dropping method is when liquid crystal is dispensed by dropping onto one of a large-scale mother substrate on which a plurality of thin film transistor array substrates are fabricated or onto another large-scale mother substrate on which color filter substrates is fabricated, and then the two mother substrates are attached to each other so that liquid crystal is uniformly distributed at the entire image display regions by the attaching pressure so as to form the liquid crystal layer. Unlike the vacuum injection method, the dropping method then proceeds with attaching the two mother substrates and separating unit liquid crystal display panels from the attached two mother substrates after the liquid crystal layer is formed.

[**0056**] Because liquid crystal is dropped directly onto the substrate, rather than being filled from outside, the seal patterns are formed in a closed pattern encompassing each outer edge of the image display parts to prevent leakage of liquid crystal to the outside. By using the dropping method, liquid crystal may be dropped within a short time compared to the vacuum injection method, and even though the liquid crystal display panel is large in size, the liquid crystal layer may be formed quickly. Price competitiveness is strengthened because the unit price of the liquid crystal display panel decreases compared to using the vacuum injection method since only the required amount of liquid crystal is dropped onto the substrate and thus the high-priced liquid crystal is not discarded.

[**0057**] Unlike the vacuum injection method, the dropping method proceeds with separating the unit liquid crystal panels from the large-scale mother substrate after the liquid crystal layer is formed. In embodiments of the present invention as described above, the seal pattern is formed on the substrate **501** using a syringe **503** filled with the sealant. However, the dispenser for a liquid crystal display panel and the method for controlling the gap between the nozzle and the substrate in accordance with the present invention can be used for dropping liquid crystal on the substrate through the dropping method. As discussed above, the dispenser for the liquid crystal display panel in accordance with embodiments of the present invention maintains a gap distance between the nozzle **502** provided at an end of the syringe **503** and the substrate **501** is precisely controlled while dispensing material from the syringe **503**. In the case of dispensing liquid crystal, the syringe **503** is filled with liquid crystal and a gap between the nozzle **502** and the substrate **501** is precisely controlled while the body **504** is repositioned to drop liquid crystal at predetermined positions on the substrate **501**.

[**0058**] In addition, the dispenser for a liquid crystal display panel and the method of controlling a gap distance between a nozzle and a substrate in accordance with the present invention can also be used in the formation of a silver (Ag) dot during the fabrication of a liquid crystal display panel. The Ag dot will now be described in detail with reference to **FIG. 9**, which is a schematic view showing a sectional structure of one edge of the liquid crystal display panel. As shown in **FIG. 9**, a liquid crystal panel is formed such that a thin film transistor array substrate **601** and a color

filter substrate **602** are attached in a facing manner with a certain gap distance maintained by a spacer **603** and a seal pattern **604**. The liquid crystal layer **605** is formed in the gap distance between the thin film transistor array substrate **601** and the color filter substrate **602**.

[**0059**] The thin film transistor array substrate **601** is formed with a protrusion and an image display part. In the protrusion part, a gate pad part connected to gate lines of the thin film transistor array substrate **601** and a data pad part connected to data lines of the thin film transistor array substrate **601** are formed. In the image display part of the thin film transistor array substrate **601**, the gate lines to which a scan signal is applied through the gate pad part and the data lines to which image information is applied through the data pad part are arranged to cross each other, and a thin film transistor for switching the liquid crystal cells is formed at the crossing. Further, a pixel electrode connected to the thin film transistor is formed at the image display part of the thin film transistor array substrate **601**.

[**0060**] In the image display part of the color filter substrate **602**, there are provided color filters separately formed at the cell regions by a black matrix. A common transparent electrode for driving the liquid crystal layer together with the pixel electrode is also formed on the thin film transistor array substrate **601**. A common voltage line **607** for applying a common voltage to the common electrode **606** on the color filter substrate **602** is formed on the thin film transistor array substrate **601**. An Ag dot **608** is formed either on the thin film transistor array substrate **601** or the color filter substrate **602** to electrically connect the common voltage line **607** and the common electrode **606** so that the common voltage applied to the common voltage line **607** may be applied to the common electrode **606** by way of the Ag dot **608**. At least one or more Ag dots **608** can be formed in each of the plurality of unit liquid crystal display panels fabricated on the large-scale mother substrate by using the dispenser for a liquid crystal display panel in accordance with embodiments of the present invention. More particularly, the syringe **503** (shown in **FIG. 6**) is filled with Ag and a gap between the nozzle **502** and the substrate **601** is precisely controlled while the body **504** is repositioned to deposit Ag dots at predetermined positions on the substrate **601**.

[**0061**] As so far described, the dispenser for a liquid crystal display panel and the method for controlling a gap distance between the substrate and the nozzle using the dispenser in accordance with the present invention has several advantages. For example, the gap distance can be set automatically with little or no input from the user. Accordingly, reliability is much improved compared to manual operation such that degradation of picture quality and yield due to a defective seal pattern can be prevented. In addition, even an unskilled user can precisely control and set the gap distance between the substrate and the nozzle in a short time so that productivity can be remarkably improved. Further, the gap distance between the nozzle and the substrate may be controlled on a real time basis while the seal pattern is being formed. Therefore, even if there is a small unevenness in the surface of the substrate, the seal pattern may be formed with a uniform height and width. Moreover, the time, effort and expense for dropping liquid crystal or forming Ag dots can also be reduced because liquid crystal or Ag, as well as the sealant, can be filled into the syringe within the body and dispensed.

[**0062**] It will be apparent to those skilled in the art that various modifications and variations can be made in the dispenser for liquid crystal display panel and method for controlling gap between substrate and nozzle using the same of the present invention without departing from the spirit or scope of the inventions. Thus, it is intended that the present invention covers the modifications and variations of this invention provided they come within the scope of the appended claims and their equivalents.

What is claimed is:

1. A dispenser for a liquid crystal display panel, comprising:

a syringe having a nozzle provided at an end thereof;

a body in which the syringe is mounted;

a vertical driving stepping motor for moving the body in a vertical direction;

a first sensor for detecting whether the nozzle of the syringe is in contact with a substrate;

a second sensor for detecting a gap distance between the nozzle and the substrate; and

a main unit for controlling the vertical driving stepping motor in response to an output from the second sensor to obtain a desired gap distance between the nozzle and the substrate.

2. The dispenser of claim 1, wherein the first sensor is a magnetic sensor.

3. The dispenser of claim 1, wherein the second sensor is a laser displacement sensor.

4. The dispenser of claim 1, further comprising:

a table for mounting the substrate.

5. The dispenser of claim 4, wherein the table is horizontally movable in forward/backward and left/right directions.

6. The dispenser of claim 1, wherein the second sensor comprises:

a light emitting unit for irradiating laser on the surface of the substrate; and

a light receiving unit for receiving laser reflected from the substrate.

7. The dispenser of claim 6, wherein the light receiving unit detects a gap distance between the nozzle and the substrate according to a position on a surface of the light receiving unit.

8. The dispenser of claim 1, wherein the syringe is filled with sealant.

9. The dispenser of claim 1, wherein the syringe is filled with liquid crystal.

10. The dispenser of claim 1, wherein the syringe is filled with Silver (Ag).

11. A method for controlling a gap between a nozzle and a substrate using a dispenser for a liquid crystal display panel, comprising:

lowering a body with a syringe mounted therein using a vertical driving stepping motor;

detecting whether a nozzle of the syringe is in contact with a substrate;

raising the body;

detecting a gap distance between the nozzle and the substrate; and

controlling the vertical driving stepping motor so that a desired gap distance is obtained between the nozzle and the substrate.

12. The method of claim 11, wherein controlling the vertical driving stepping motor includes obtaining the desired gap distance of about **40**µm.

13. The method of claim 11, further comprising repositioning the body above the substrate while maintaining the desired gap distance between the body and the substrate.

14. The method of claim 11, wherein raising the body includes raising the body when the nozzle is detected to be in contact with the substrate.

15. The method of claim 11, wherein detecting the gap distance between the nozzle and the substrate includes:

irradiating light from a light emitting unit mounted on the body onto the substrate;

receiving a reflected light from the substrate using a light receiving unit mounted on the body; and

determining the gap distance according to a position on a surface of the light receiving unit when the reflected light is incident and received.

* * * * *

专利名称(译)	用于液晶显示板的分配器和使用该分配器控制基板和喷嘴之间的间隙的方法		
公开(公告)号	US20040131758A1	公开(公告)日	2004-07-08
申请号	US10/726584	申请日	2003-12-04
[标]申请(专利权)人(译)	乐金显示有限公司		
申请(专利权)人(译)	LG.PHILIPS LCD CO. , LTD.		
当前申请(专利权)人(译)	LG DISPLAY CO. , LTD.		
[标]发明人	JUNG SUNG SU KWAK YONG KEUN		
发明人	JUNG, SUNG-SU KWAK, YONG-KEUN		
IPC分类号	G02F1/13 B05C5/02 G02F1/1339 G02F1/1341 B05D5/12 B05D1/02 B05D1/00 B05D5/06 B05C11/00		
CPC分类号	G02F1/1339 B05C5/0216		
优先权	1020020081439 2002-12-18 KR		
其他公开文献	US7547362		
外部链接	Espacenet USPTO		

摘要(译)

一种用于液晶显示板的分配器，包括：注射器，其具有设置在其端部的喷嘴；安装注射器的主体；垂直驱动步进电机，用于在垂直方向上移动主体；第一传感器，用于检测是否注射器的喷嘴与基板接触，第二传感器用于检测喷嘴和基板之间的间隙距离，主单元用于响应于第二传感器的输出控制垂直驱动步进电机以获得所需的喷嘴和基板之间的间隙距离。

