



(19) **United States**

(12) **Patent Application Publication**
Stephenson et al.

(10) **Pub. No.: US 2003/0169221 A1**

(43) **Pub. Date: Sep. 11, 2003**

(54) **UNIPOLAR DRIVE CHIP FOR
CHOLESTERIC LIQUID CRYSTAL
DISPLAYS**

Publication Classification

(51) **Int. Cl.⁷ G09G 3/36**

(52) **U.S. Cl. 345/87**

(75) **Inventors: Stanley W. Stephenson**, Spencerport,
NY (US); **David M. Johnson**,
Rochester, NY (US); **Xiang-Dong Mi**,
Rochester, NY (US)

(57) **ABSTRACT**

Apparatus for driving a cholesteric liquid crystal display wherein the display includes cholesteric liquid crystals having a first planar reflective state and a second transparent focal conic state, which is respectively responsive to different applied fields. The apparatus further includes an addressing structure having rows and columns of conductors arranged so that when a column and a row overlap, they define a selectable pixel or segment to be viewable or non-viewable, and a single drive chip responsive to a single input voltage for applying selected voltages to rows and columns of conductors, so that selectable unipolar fields are applied across the cholesteric liquid crystals of the pixels to selectively change the state of the cholesteric liquid crystal.

Correspondence Address:

Thomas H. Close
Patent Legal Staff
Eastman Kodak Company
343 State Street
Rochester, NY 14650-2201 (US)

(73) **Assignee: Eastman Kodak Company**

(21) **Appl. No.: 10/094,070**

(22) **Filed: Mar. 8, 2002**

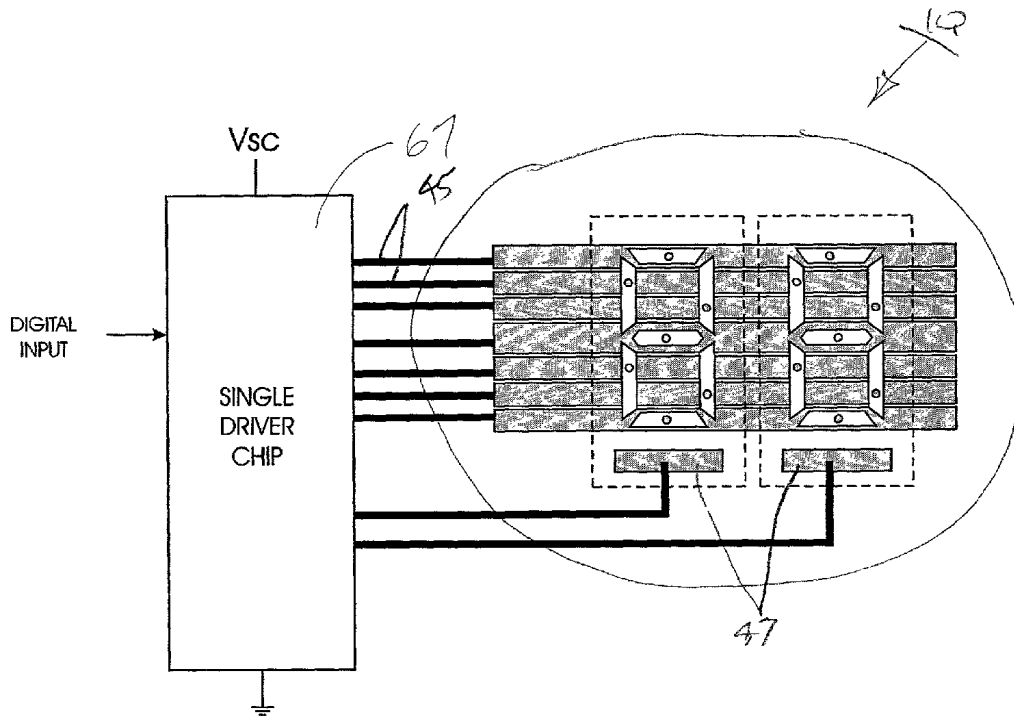

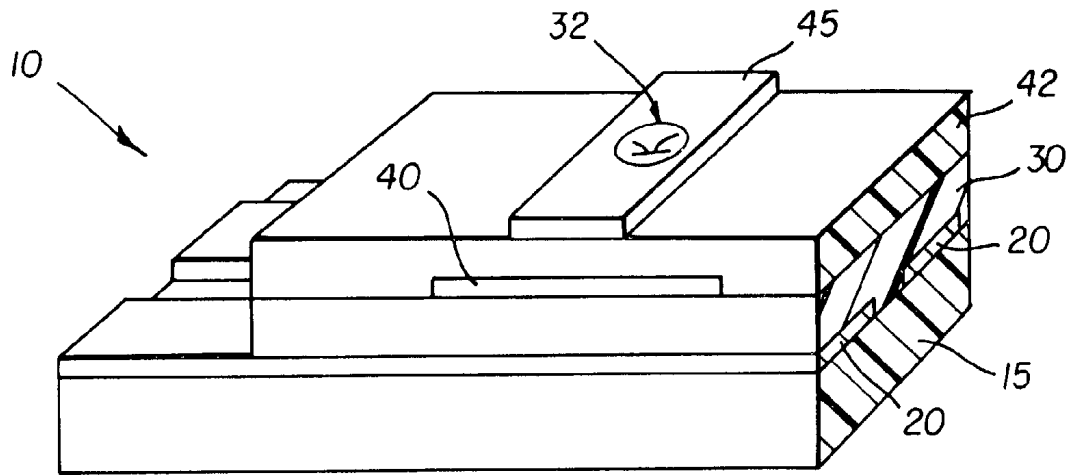

FIG. 1

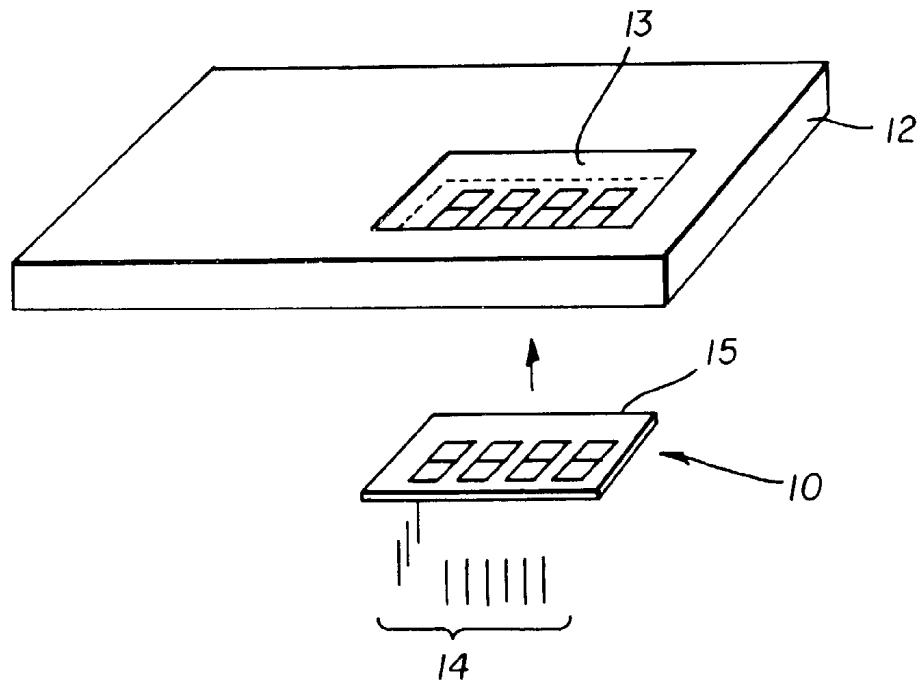

FIG. 2

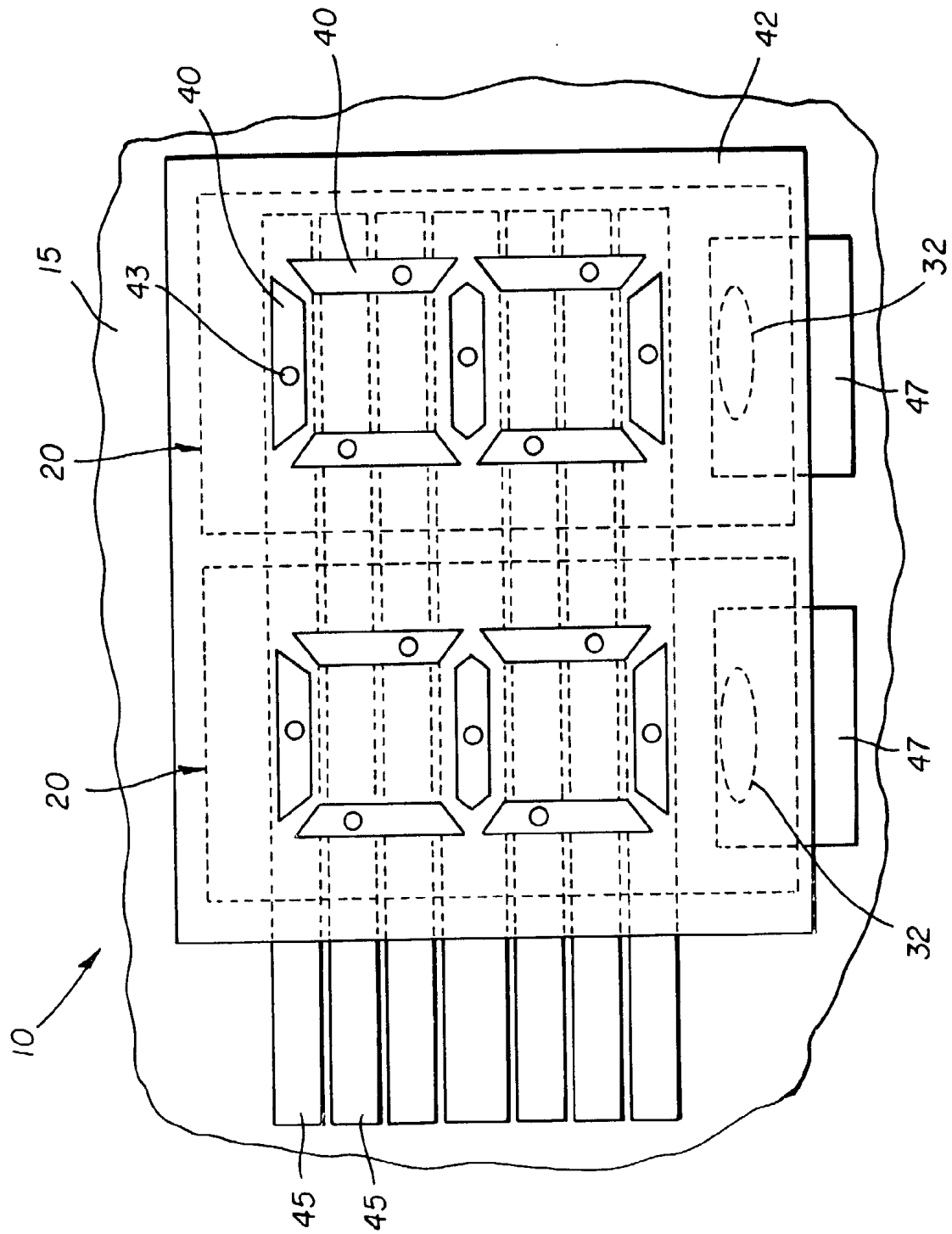

FIG. 3

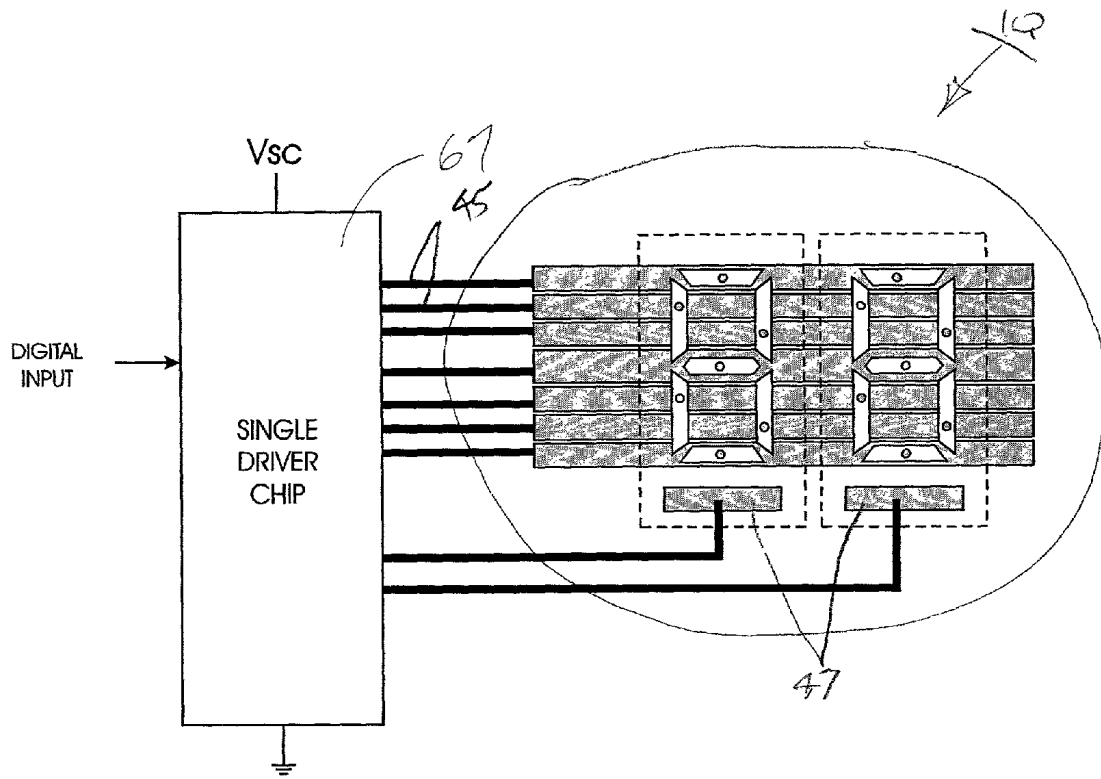

FIG. 4

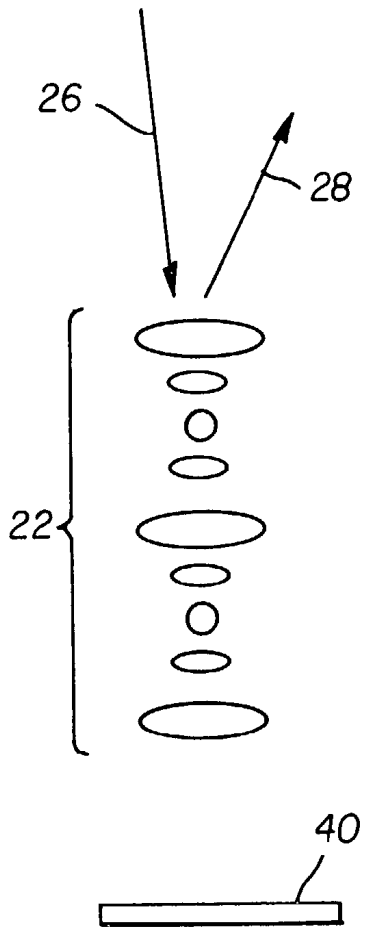

FIG. 5A

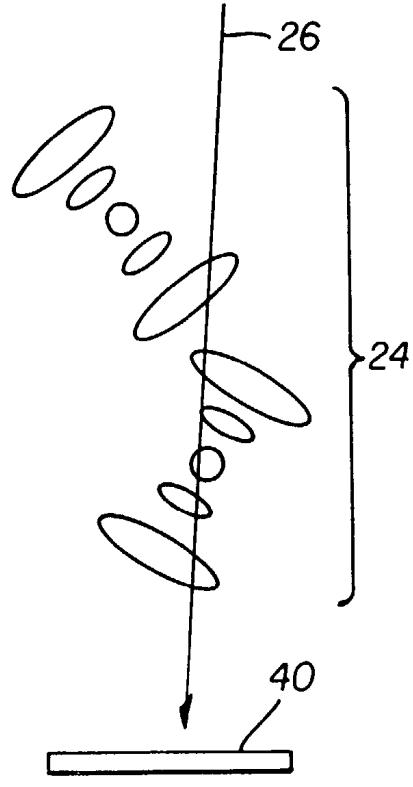

FIG. 5B

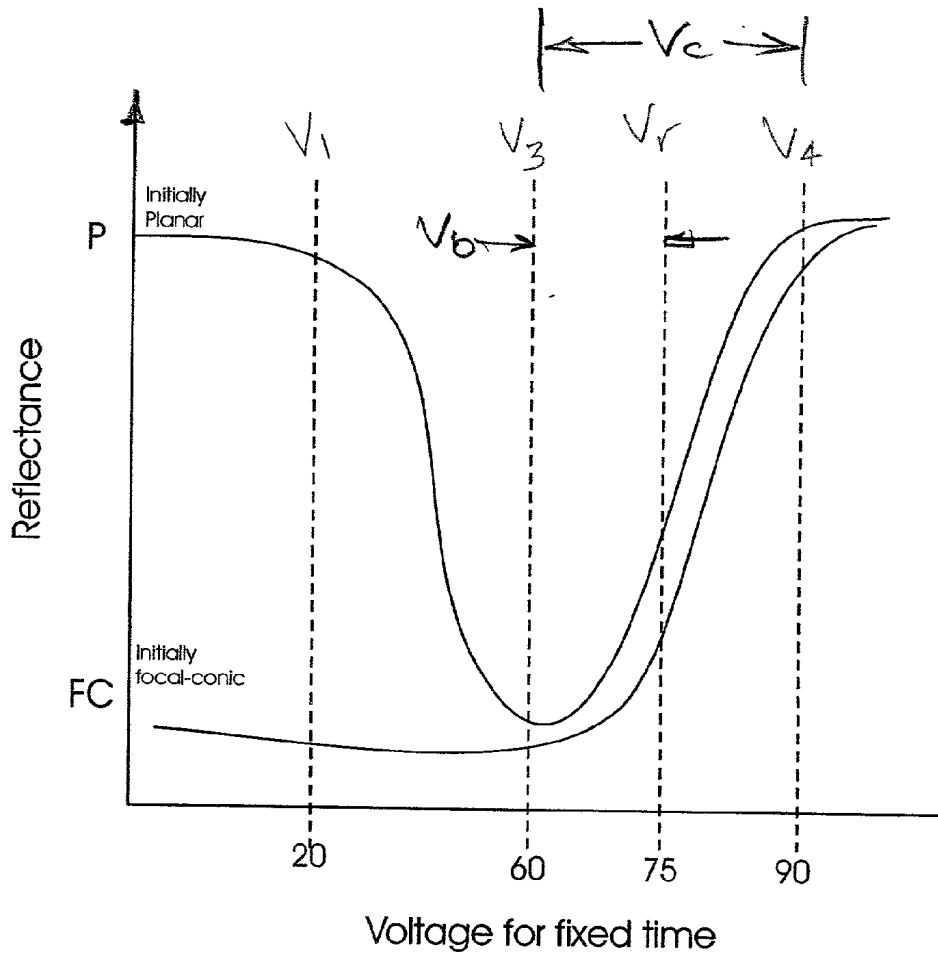

FIG. 6

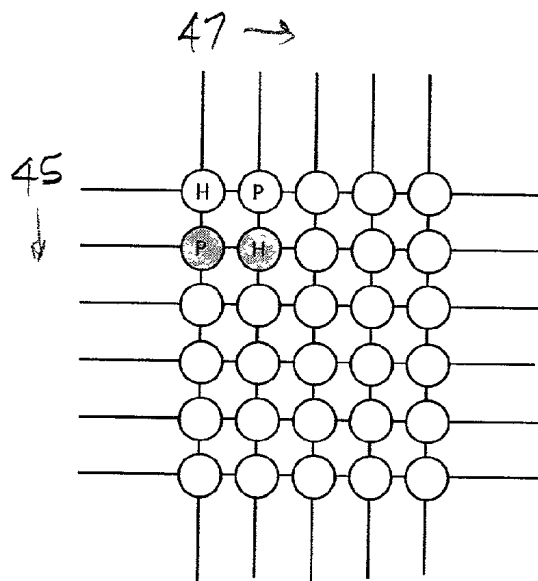

FIG. 7

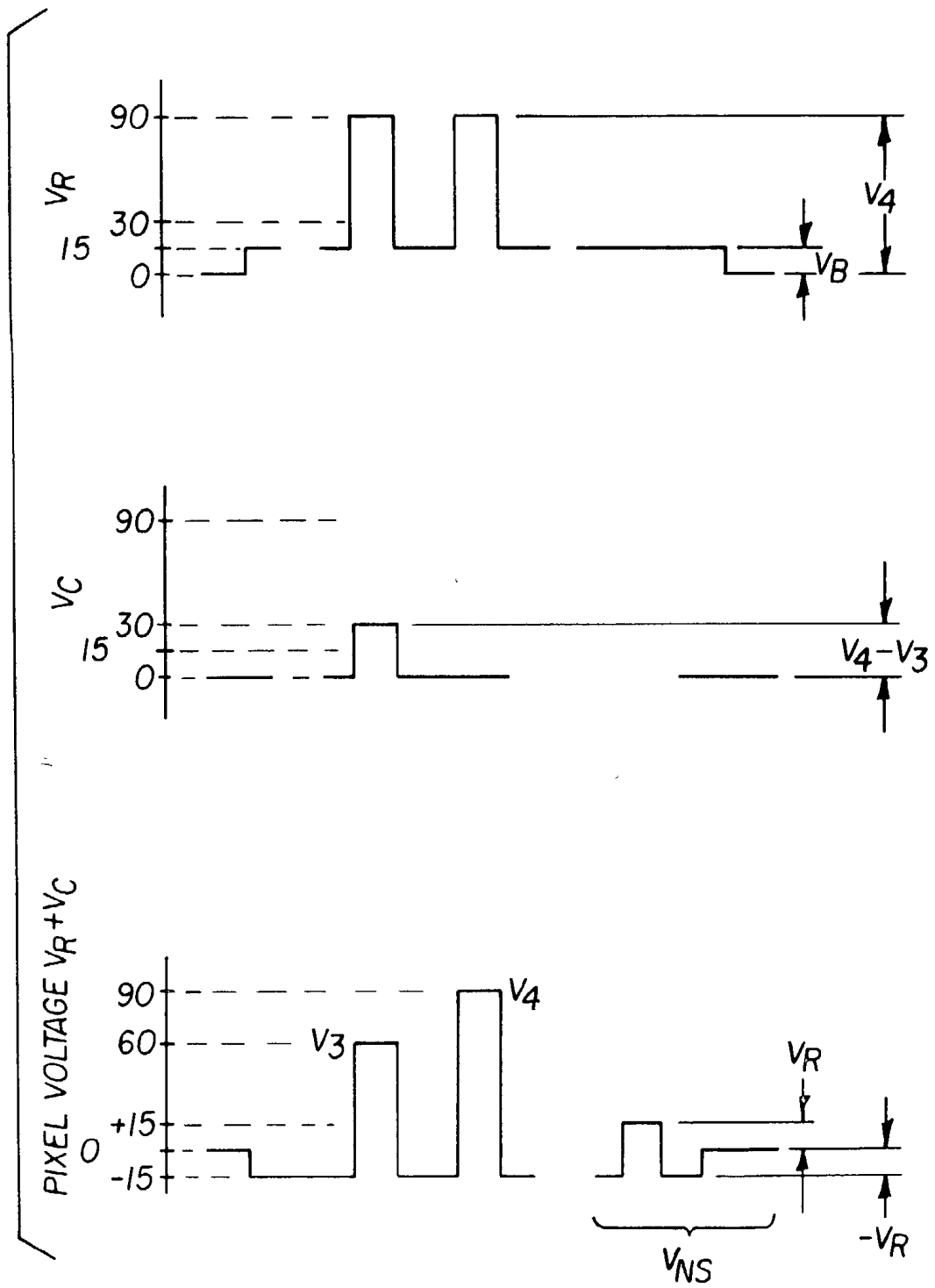

FIG 8

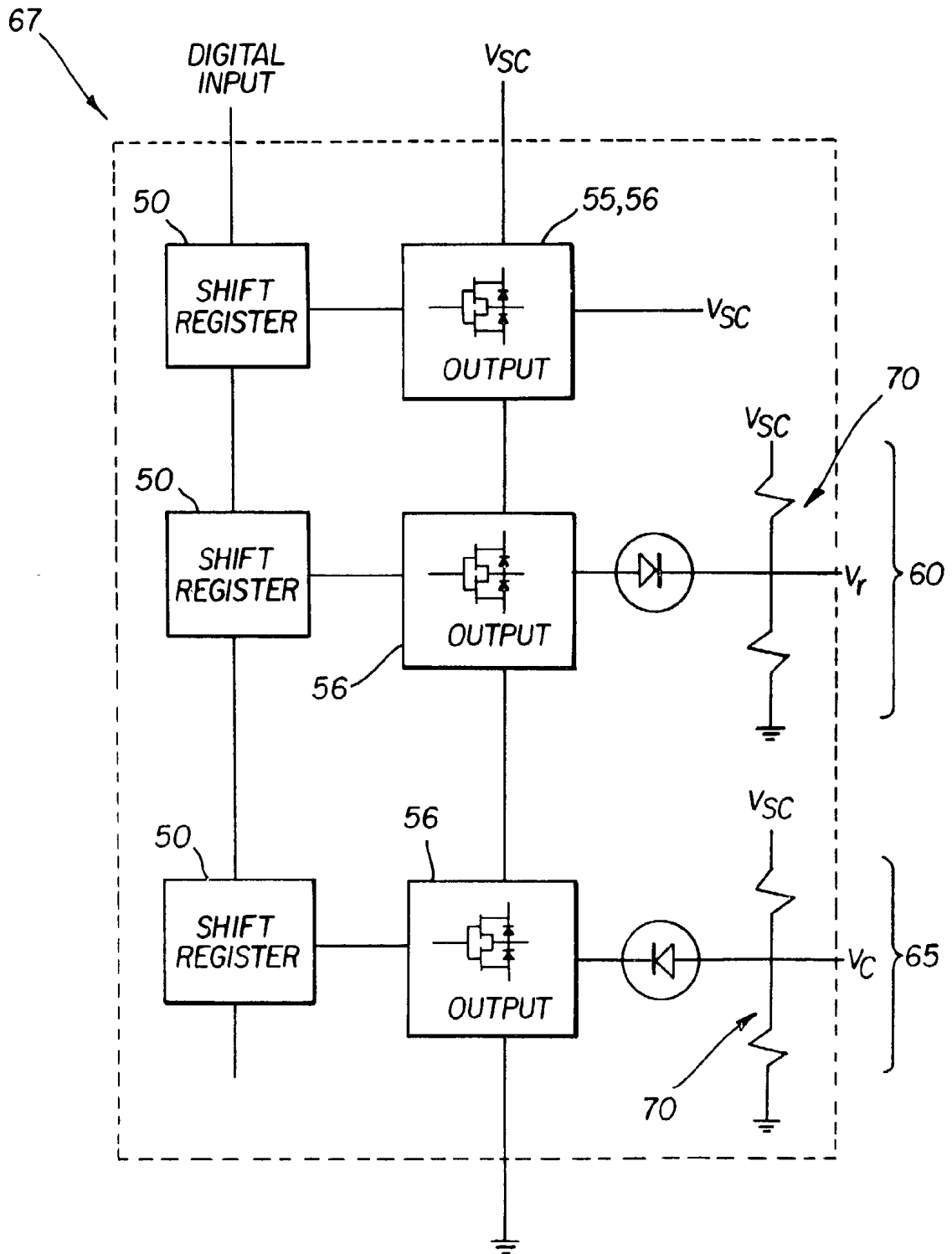

FIG. 9

UNIPOLAR DRIVE CHIP FOR CHOLESTERIC LIQUID CRYSTAL DISPLAYS

CROSS REFERENCE TO RELATED APPLICATION

[0001] Reference is made to commonly assigned U.S. patent application Ser. No. 09/379,776, filed Aug. 24, 1999 by Dwight J. Petruichik et al.; U.S. patent application Ser. No. 09/723,389, filed Nov. 28, 2000 by David M. Johnson et al.; and U.S. patent application Ser. No. 09/851,868, filed May 9, 2001 by Stanley W. Stephenson et al.; the disclosures of which are incorporated herein by reference.

FIELD OF THE INVENTION

[0002] The present invention relates to electronic drives for cholesteric liquid crystal displays.

BACKGROUND OF THE INVENTION

[0003] Currently, information on flat substrates can be displayed using assembled sheets of paper carrying permanent inks or displayed on electronically modulated surfaces such as cathode ray displays or liquid crystal displays. Other sheet materials can carry magnetically written areas to carry ticketing or financial information, however magnetically written data is not visible.

[0004] Current flat panel displays use two transparent glass plates as substrates. In a typical embodiment, such as one set forth in U.S. Pat. No. 5,503,952, a set of electrical traces is sputtered in a pattern of parallel lines that form a first set of conductive traces. A second substrate is similarly coated with a set of traces having a transparent conductive coating. Coatings are applied and the surfaces rubbed to orient liquid crystals. The two substrates are spaced apart and the space between the two substrates is filled with a liquid crystal material. Pairs of conductors from either set are selected and energized to alter the optical transmission properties of the liquid crystal material. Such displays are expensive, and currently are limited to applications having long lifetimes.

[0005] Fabrication of flexible, electronically written display sheets using conventional nematic liquid crystal materials is disclosed in U.S. Pat. No. 4,435,047. A first sheet has transparent indium-tin-oxide (ITO) conductive areas and a second sheet has electrically conductive inks printed on display areas. The sheets can be thin glass, but in practice have been formed of Mylar polyester. A dispersion of liquid crystal material in a binder is coated on the first sheet, and the second sheet is bonded to the liquid crystal material. Electrical potential is applied to opposing conductive areas to operate on the liquid crystal material and expose display areas. The display uses nematic liquid crystal materials, which ceases to present an image when de-energized. Privacy windows are created from such structures using the scattering properties of polymer dispersed nematic liquid crystals. Polymer dispersed nematic liquid crystals require continuous electrical drive to remain transparent.

[0006] U.S. Pat. No. 5,437,811 discloses a light-modulating cell having a chiral nematic liquid crystal in polymeric domains contained by conventional patterned glass substrates. The chiral nematic liquid crystal has the property of being driven between a planar state reflecting a specific

visible wavelength of light and a light scattering focal conic state. Chiral nematic material has the capacity of maintaining one of the given states in the absence of an electric field.

[0007] In "Liquid Crystal Dispersions", World Science, Singapore, 1995, page 408, Paul Drzaic discusses the electrical drive of cholesteric liquid crystal displays. Drzaic also states on page 29 that "The use of gelatin, however, creates a material that is too conductive for practical use in electrically addressed PDLC systems". Drzaic further states ". . . actual displays require AC signals to prevent electrochemical degradation." Subsequent patents support Drzaic's assumptions. Later patents such as U.S. Pat. Nos. 5,251,048, 5,644,330, and 5,748,277 all require AC fields having a net zero field for matrix cholesteric liquid crystal displays to prevent ionic damage to the display. The cited patents have display structures formed using expensive display structures and processes applicable to long life situations that require AC drive schemes.

[0008] The drive schemes require that each element be written using alternating electrical fields that provide a net zero field across the display to prevent ionic migration. AC drives require large numbers of power supplies and large numbers of switching elements per line.

[0009] Prior art electrical schemes, such as U.S. Pat. No. 5,644,330, require four power supplies to supply +Vc, -Vc, +VR, -VR and ground. Each line output must switch one of three voltages to each line of a matrix display. Conventional bipolar drive schemes, as disclosed in U.S. Pat. No. 5,748,277, require the use of expensive analog switching elements as found in a Supertex HV204 8-Channel High Voltage Analog Switch. One analog switch is required for each voltage applied to each trace of the display. Such expensive chips prohibit low cost commercialization. Even more complex switching schemes have been proposed which increase the number of power supplies and analog switches and are disclosed in other patents, such as U.S. Pat. No. 5,748,277.

[0010] U.S. Pat. No. 5,251,048 by Doane et al., discloses a method for driving a cholesteric liquid crystal display using a single chip HD44780 CMOS dot matrix driver integrated circuit available from Hitachi America, Ltd. of Brisbane, Calif. A current model of that chip is HD66712U of the same company. The chips are used to drive nematic liquid crystal display. The Doane et al. patent discloses a method of using nematic liquid crystal drive chips to drive a chiral nematic (cholesteric) liquid crystal display. The table at the bottom of column 8 in the cited reference shows that for each positive voltage, there is an equal and opposite negative voltage for a bipolar drive. The chip for nematic systems is complex due to the use of a bipolar drive system that is also used for cholesteric displays in the Doane patent. Such drives require multiple drive voltages (V1 to V5) to write a display.

[0011] Cholesteric displays use expensive conventional flat panel display processes. Consequently, current state of the art requires bipolar voltage drive schemes for cholesteric displays to prevent ionic damage. The bipolar drives require at least two voltages and two separate semiconductor switching elements for each drive line.

[0012] Prior art for driving cholesteric liquid crystal displays has been directed towards matrix displays with large numbers of rows and columns, which require multiple drive

chips. Display architecture has been directed towards multiple drive chips and power supplies and control logic. Single chip drive systems require multiple voltages that are switched to create bipolar drive schemes. Such architectures are expensive. Certain display applications require few drive lines to present information. It would be useful to drive a simple cholesteric display with a single drive chip using a simple drive method.

SUMMARY OF THE INVENTION

[0013] It is an object of the present invention to provide a drive for low cost cholesteric memory displays generated using coated polymeric dispersed cholesteric liquid crystals which overcome the problems associated with bipolar fields in liquid crystals.

[0014] It is another object of the present invention to provide a simpler, lower cost method of driving coated polymer dispersed cholesteric materials on flexible substrates.

[0015] These objects are achieved by an apparatus for driving a cholesteric liquid crystal display comprising:

[0016] a) the display including cholesteric liquid crystals having a first planar reflective state and a second transparent focal conic state, which is respectively responsive to different applied fields;

[0017] b) an addressing structure having rows and columns of conductors arranged so that when a column and a row overlap, they define a Selectable pixel or segment to be viewable or non-viewable; and

[0018] c) a single drive chip responsive to a single input voltage for applying selected voltages to rows and columns of conductors, so that selectable unipolar fields are applied across the cholesteric liquid crystals of the pixels to selectively change the state of the cholesteric liquid crystal.

[0019] The present invention makes use of unipolar drive systems for cholesteric liquid crystal displays that simplifies the drive structure and requires only a single voltage to drive such a display. Moreover, the present invention reduces the number of voltage switching elements and requirement for a complex power supply. It is a feature of the present invention that it requires only a single drive chip and a single power supply to write a display.

BRIEF DESCRIPTION OF THE DRAWINGS

[0020] FIG. 1 is an isometric partial view of a cholesteric liquid crystal display made in accordance with the present invention;

[0021] FIG. 2 is an assembly diagram of the display in FIG. 1 being attached to a card;

[0022] FIG. 3 is a top view of the display of FIG. 1;

[0023] FIG. 4 is a schematic showing the interconnect of a display to a drive chip in accordance with the present invention;

[0024] FIG. 5A is a schematic sectional view of a chiral nematic material in a planar state reflecting light;

[0025] FIG. 5B is a schematic sectional view of a chiral nematic material in a focal conic state transmitting light;

[0026] FIG. 6 is a plot of the response of a first polymer dispersed cholesteric material to a series of pulsed electrical fields;

[0027] FIG. 7 is a schematic representation of a matrix array of cholesteric liquid crystal elements;

[0028] FIG. 8 is an electrical schematic of drive waveforms in accordance with the present invention; and

[0029] FIG. 9 is a diagram of the internal architecture of a drive chip in accordance with the present embodiment.

DETAILED DESCRIPTION OF THE INVENTION

[0030] FIG. 1 is an isometric partial view of a new structure for a display 10 made in accordance with the invention. Display 10 includes a flexible substrate 15, which is a thin transparent polymeric material, such as Kodak Estar film base formed of polyester plastic that has a thickness of between 20 and 200 microns. In an exemplary embodiment, substrate 15 can be a 125-micron thick sheet of polyester film base. Other polymers, such as transparent polycarbonate, can also be used.

[0031] First patterned conductors 20 are formed over substrate 15. First patterned conductors 20 can be tin-oxide or indium-tin-oxide (ITO), with ITO being the preferred material. Typically the material of first patterned conductors 20 is sputtered as a layer over substrate 15 having a resistance of less than 250 ohms per square. The layer is then patterned to form first patterned conductors 20 in any well known manner. Alternatively, first patterned conductors 20 can be an opaque electrical conductor material such as copper, aluminum, or nickel. If first patterned conductors 20 are opaque metal, the metal can be a metal oxide to create light absorbing first patterned conductors 20. First patterned conductors 20 are formed in the conductive layer by conventional lithographic or laser etching means.

[0032] A polymer dispersed cholesteric layer 30 overlays first patterned conductors 20. Polymer dispersed cholesteric layer 30 includes a polymeric dispersed cholesteric liquid crystal material, such as those disclosed in U.S. Pat. No. 5,695,682, the disclosure of which is incorporated by reference. Application of electrical fields of various intensity and duration can drive a chiral nematic material (cholesteric) into a reflective state, to a transmissive state, or an intermediate state. These materials have the advantage of maintaining a given state indefinitely after the field is removed. Cholesteric liquid crystal materials are, for example, supplied by Merck BL112, BL118 or BL126, available from E.M. Industries of Hawthorne, N.Y.

[0033] In the preferred embodiment, polymer dispersed cholesteric layer 30 is E.M. Industries' cholesteric material BL-118 dispersed in deionized photographic gelatin. The liquid crystal material is dispersed at 8% concentration in a 5% deionized gelatin aqueous solution. The mixture is dispersed to create 10-micron diameter domains of the liquid crystal in aqueous suspension. The material is coated over a patterned ITO polyester sheet to provide a 9-micron thick polymer dispersed cholesteric coating. Other organic binders such as polyvinyl alcohol (PVA) or polyethylene oxide

(PEO) can be used. Such compounds are machine coatable on equipment associated with photographic films.

[0034] Second patterned conductors **40** overlay polymer dispersed cholesteric layer **30**. Second patterned conductors **40** should have sufficient conductivity to carry a field across polymer dispersed cholesteric layer **30**. Second patterned conductors **40** can be formed in a vacuum environment using materials such as aluminum, tin, silver, platinum, carbon, tungsten, molybdenum, tin, or indium or combinations thereof. The second patterned conductors **40** are as shown in the form of a deposited layer. Oxides of said metals could be used to darken second patterned conductors **40**. The metal material can be excited by energy from resistance heating, cathodic arc, electron beam, sputtering, or magnetron excitation. Tin-oxide or indium-tin oxide coatings permit second patterned conductors **40** to be transparent.

[0035] In a preferred embodiment, second patterned conductors **40** are printed conductive ink such as Electrodag 423SS screen printable electrical conductive material from Acheson Corporation. Such printed materials are finely divided graphite particles in a thermoplastic resin. The second patterned conductors **40** are formed using printed inks to reduce cost display. The use of a flexible support for substrate **15**, the sputter layer laser etched to form first patterned conductors **20**, machine coating polymer dispersed cholesteric layer **30**, and printing second patterned conductors **40** permits the fabrication of very low cost memory displays. Small displays formed using these methods can be used as electronically rewritable tags for inexpensive, limited rewrite applications.

[0036] A dielectric **42** can be printed over second patterned conductors **40** and has through vias **43** that permit interconnection between second patterned conductors **40** and conductive material that create row lines **45**. Row lines **45** can be formed from the same screen printed, electrically conductive material used to form second patterned conductors **40**. The connection of sets of second conductors **40** creates functional rows of electrically responsive areas.

[0037] FIG. 2, an assembly diagram of display **10** in FIG. 1, beings attached to a card **12**. Card **12** can be a transparent sheet, approximately 0.5 millimeter in thickness which has information printed on one surface. A non-printed area **13** provides a clear window for viewing the contents of display **10**, which has been bonded to the opposite side of card **12**. Display **10** in this example has a transparent substrate **15**, and is inverted from the position shown in FIG. 1 during the attachment process. Information written to display **10** is seen through non-printed area **13** of card **12** and through transparent substrate **15**. Alternatively, non-printed area **13** of card **12** can be an opening through an opaque card **12**. Card **12** with attached display **10** can be inserted into a holder (not shown) and contacts **14** can connect to first patterned conductors **20** and row lines **45** on display **10** to update information on display **10**. Display **10** can be used a financial transaction (credit/debit) card typically requiring less than 10,000 updated images.

[0038] FIG. 3 is a front view of display **10** having a matrix addressing structure in accordance with the present invention. Display **10** has two seven-segment characters built so that segments from each character are connected to seven row lines **45** and transparent electrodes in front of each character acting as column lines **47**. Looking through sub-

strate **15**, first patterned conductors **20** are transparent conductive electrodes over each seven-segment character. Polymer dispersed cholesteric layer **30** is coated behind patterned first conductors **20**. A portion of polymer dispersed cholesteric material **30** is removed to form connection area **32** for each column line **47**. Second patterned conductors **40** are printed to form the seven segments of each character within the boundaries of first patterned conductor **20**. Dielectric **42** is printed across the display and has through via **43** to permit electrical connection of common character segments in each character to row lines **45**. A final layer of conductive material is printed across the back of the display to form row lines **45** and column lines **47**. Where one of the column **47** and the second patterned conductor **40** connected to row **45** overlap, they define a selectable pixel or segment to be viewable or non-viewable. The completed display is a matrix addressable cholesteric display. Display **10** has seven rows **45** and two columns **47** for each of two characters, and uses less than nine driven lines.

[0039] It is advantageous to write to display **10** directly with a single drive chip **67**. FIG. 4 is a schematic diagram showing the interconnect of display **10** to drive chip **67** in accordance with the present invention. Display **10** is connected directly to output pins on single drive chip **67** which connect to both row lines **45** and column lines **47**.

[0040] FIG. 5A and FIG. 5B show two stable states of cholesteric liquid crystals. In FIG. 5A, a high voltage field has been applied and quickly switched to zero potential, which converts cholesteric liquid crystal to a planar state **22**. Incident light **26** striking cholesteric liquid crystal in planar state **22** is reflected as reflected light **28** to create a bright image. In FIG. 5B, application of a lower voltage field leaves cholesteric liquid crystals in a transparent focal conic state **24**. Incident light **26** striking a cholesteric liquid crystal in focal conic state **24** will be transmitted through the cholesteric material. Second patterned conductors **40** can be black which will absorb incident light **26** to create a dark image when the liquid crystal material is in focal conic state **24**. As a result, a viewer perceives a bright or dark image depending on if the cholesteric material is in planar state **22** or focal conic state **24**, respectively.

[0041] FIG. 6 is a plot of the response of cholesteric material to a pulsed electrical field. Such curves can be found in U.S. Pat. Nos. 5,453,863 and 5,695,682 and are also found in the above-cited Drzaic reference. For a given pulse time, typically between 5 and 200 milliseconds, a pulse at a given voltage can change the optical state of a cholesteric liquid crystal. Disturbance voltage **V1** is the highest voltage pulse that can be applied to cholesteric material without changing a written state. Focal conic voltage **V3** is a higher voltage pulse that drives cholesteric material into the focal conic state irrespective of the materials initial state. Planar voltage **V4** is an even higher voltage that drives cholesteric material into the planar, reflective state irrespective of the cholesteric material's initial state.

[0042] FIG. 7 is a schematic representation of a matrix array of cholesteric liquid crystal elements written using a unipolar drive scheme. Row voltage V_r is set midway between **V3** and **V4** on a selected row while the remaining rows are set to a ground voltage. Either a positive or negative column voltage V_c is applied to columns **47** in a written row offset V_r to either focal conic voltage **V3** or planar voltage

V4 on the cholesteric material, depending on the desired final state of a row of pixels. The positive column voltage V_c and negative column voltage $-V_c$ are individually below disturbance voltage V_1 so that unwritten rows held at ground potential experience voltages less than disturbance voltage V_1 and are not changed. These material characteristics permit sequential row writing.

[0043] In an experiment, gelatin dispersed cholesteric material dispersed and coated to the preferred embodiment was coated over ITO coated flexible substrate 15 to form polymer dispersed cholesteric layer 30. A one inch square conductive patch was printed over the gelatin dispersed cholesteric material to create a test display 10. A 20 millisecond unipolar field was switched across the material every 5 seconds to switch the state of the material between the planar and focal conic states. The gelatin dispersed cholesteric material was driven through a limited life test of 10,000 rewrites. The test patch operated with no apparent visible degradation throughout the life test. The life test was then extended to 100,000 cycles. The test display 10 continued to perform with little degradation. From this experiment, it was concluded that polymeric dispersed cholesteric materials on flexible substrates 15 with printed conductors can be intermittently driven by unipolar (DC) fields for the limited number of life cycles needed for limited-life display applications. Such displays in simple seven-segment format benefit from a drive scheme that uses a single drive chip 67. It is of further benefit that single drive chip 67 can use a single chip voltage V_{sc} .

[0044] FIG. 8 is a diagram of the waveforms used to write display 10 using the new DC drive scheme. When display 10 is not being written, the voltage supplied to rows and columns are all set to ground (zero) potential. When writing is initiated, drive chip 67 creates a positive 15 volt bias voltage V_b on the row drivers. The bias voltage is set to a potential equal to half the difference in voltage between focal conic voltage V_3 and planar voltage V_4 , which in the exemplary embodiment is 15 volts. During the writing process row lines will receive either 15 or 90 volts. The row being written is set to 90 volts, while the non-written rows are maintained at the 15 volt bias voltage V_b . Single chip voltage V_{sc} is converted within the chip to a lower column voltage V_c , equal to $V_4 - V_3$. In the exemplary embodiment column lines are switched between a 30 volt column voltage V_c and ground. Unwritten rows experience half the column voltage because the unwritten rows are held at the bias voltage V_b instead of ground. Unwritten rows experience half the column voltage. The configuration permits sequential writing of a matrix display using DC fields.

[0045] A row of data is written by switching row voltage V_r from 15 volts to 90 volts. Column voltages V_c are held at either ground or 30 volts. If column voltage V_c is at 30 volts, cholesteric liquid crystal material experiences a unipolar focal conic voltage V_3 and is switched into the focal conic state (FC). If column voltage is at ground state (0 volts), cholesteric liquid crystal experiences a unipolar planar voltage V_3 and is switched into the planar state (P). Unwritten rows are held at bias voltage V_b when and experience either -15 and $+15$ volts from column voltage V_c as rows are written. The 15 volt column voltage is below disturbance voltage V_1 , and image data in unwritten rows are not disturbed. At the end of writing, all outputs of drive chip 67 are immediately returned to the ground state, and no

fields are present on display 10. The method permits sequential row writing of a cholesteric matrix display 10 with very simple unipolar pulses that have a minimum of switched states. The drivers of single drive chip 67 can be simple source-sink semiconductor structures. Such waveforms can be generated directly by simple microprocessors with simple processing algorithms, and do not require complex switching logic required to generate bipolar fields on cholesteric materials.

[0046] FIG. 9 is a diagram of the internal architecture of drive chip 67 in accordance with the present embodiment. Within the drive chip 67, a set of conventional shift registers/latches 50 are sequentially loaded with binary data and are connected to outputs 56 that are in of conventional push-pull CMOS design. A single drive voltage V_{sc} is applied to drive chip 67. A first output 55 provides single chip voltage V_{sc} to passive components attached to each output 56. Passive components are resistors and diodes that provide voltage divider network 70 voltages to create appropriate voltages for each row line 45 and each column line 47. When first output 55 is switched off, all outputs 56 are at ground potential. When first output chip 55 supplies single chip voltage V_{sc} to the other outputs, row voltage outputs switch between 90 or 15 volts, and column voltage outputs switch between 0 and 30 volts due to the voltage divider networks 70 attached to each output. A microprocessor (not shown) sequentially loads shift registers/latches 50 to produce the waveforms shown in FIG. 8 to provide the desired display image. With the unipolar drive scheme, the time between state changes of drive chip 67 is in milliseconds and few state changes are required, permitting a microprocessor to directly control writing of display 10. Single chip 67 provides a simple interface between a microprocessor and display 10. The slow speed and few state changes eliminate complex circuitry found internal to chips using bipolar signals.

[0047] The invention has been described in detail with particular reference to certain preferred embodiments thereof, but it will be understood that variations and modifications can be effected within the spirit and scope of the invention.

PARTS LIST

- [0048] 10 display
- [0049] 12 card
- [0050] 13 non-printed area
- [0051] 14 contacts
- [0052] 15 substrate
- [0053] 20 first patterned conductors
- [0054] 22 planar state
- [0055] 24 focal conic state
- [0056] 26 incident light
- [0057] 28 reflected light
- [0058] 30 polymer dispersed cholesteric layer
- [0059] 32 connection area
- [0060] 40 second patterned conductors

- [0061] 42 dielectric
- [0062] 43 through via
- [0063] 45 row lines
- [0064] 47 column lines
- [0065] 50 shift registers/latches
- [0066] 55 first output
- [0067] 56 outputs
- [0068] 67 single drive chip
- [0069] 70 voltage divider network
- [0070] V1 disturbance voltage
- [0071] V3 focal conic voltage
- [0072] V4 planar voltage
- [0073] Vc column voltage

PARTS LIST (con't)

- [0074] Vr row voltage
- [0075] Vsc single chip voltage
- [0076] Vb bias voltage

What is claimed is:

1. Apparatus for driving a cholesteric liquid crystal display comprising:

- a) the display including cholesteric liquid crystals having a first planar reflective state and a second transparent focal conic state, which is respectively responsive to different applied fields;
- b) an addressing structure having rows and columns of conductors arranged so that when a column and a row overlap, they define a selectable pixel or segment to be viewable or non-viewable; and
- c) a single drive chip responsive to a single input voltage for applying selected voltages to rows and columns of conductors, so that selectable unipolar fields are applied across the cholesteric liquid crystals of the pixels to selectively change the state of the cholesteric liquid crystal.

2. The apparatus of claim 1 wherein said single drive chip includes voltage dividing means for providing one of two selectable voltages for each column and one of two selectable voltages for each row; and means for selecting one of the first and second fixed voltages for causing the voltage divider means to provide one of two voltages for a column and one of the two voltages for a row so that a voltage for a particular pixel or segment causes such pixel or segment to be in a transparent focal conic state or planar reflective state.

* * * * *

专利名称(译)	用于胆甾型液晶显示器的单极驱动芯片		
公开(公告)号	US20030169221A1	公开(公告)日	2003-09-11
申请号	US10/094070	申请日	2002-03-08
[标]申请(专利权)人(译)	伊斯曼柯达公司		
申请(专利权)人(译)	伊士曼柯达公司		
当前申请(专利权)人(译)	工业技术研究院		
[标]发明人	STEPHENSON STANLEY W JOHNSON DAVID M MI XIANG DONG		
发明人	STEPHENSON, STANLEY W. JOHNSON, DAVID M. MI, XIANG-DONG		
IPC分类号	G02F1/141 G02F1/133 G02F1/137 G09G3/18 G09G3/20 G09G3/36		
CPC分类号	G09G3/18 G09G3/3629 G09G2300/0486 G09G3/3692 G09G3/3681		
其他公开文献	US7307608		
外部链接	Espacenet USPTO		

摘要(译)

用于驱动胆甾型液晶显示器的装置，其中显示器包括具有第一平面反射状态和第二透明焦锥状态的胆甾型液晶，其分别响应于不同的施加场。该装置还包括寻址结构，该寻址结构具有行和列的导体，其布置成使得当列和行重叠时，它们限定可选择的像素或片段以便可观看或不可观看，并且单个驱动芯片响应于单个输入电压为了将选定的电压施加到导体的行和列，使得可选择的单极场施加在像素的胆甾型液晶上，以选择性地改变胆甾型液晶的状态。

