



US 20070195249A1

(19) **United States**

(12) **Patent Application Publication** (10) **Pub. No.: US 2007/0195249 A1**

Mun et al.

(43) **Pub. Date: Aug. 23, 2007**

(54) **LIQUID CRYSTAL DISPLAY HAVING WIDE VIEWING ANGLE**

Nov. 22, 2000 (KR)..... 2000-0069723

Publication Classification

(76) Inventors: **Joong-Hyun Mun**, Suwon-City (KR);
Jang-Kun Song, Seoul (KR)

(51) **Int. Cl.**
G02F 1/1343 (2006.01)
(52) **U.S. Cl.** **349/139**

Correspondence Address:
MACPHERSON KWOK CHEN & HEID LLP
2033 GATEWAY PLACE
SUITE 400
SAN JOSE, CA 95110 (US)

(57) **ABSTRACT**

Disclosed is a liquid crystal display comprising a first substrate; pixel electrodes formed on the first substrate, the pixel electrodes having formed thereon a first aperture pattern; a second substrate provided opposing the first substrate; a common electrode formed on the second substrate, the common electrode having formed thereon a second aperture pattern; liquid crystal material injected between the first and second substrates; and spacers provided between the first and second substrates for maintaining a predetermined gap between the first and second substrates, wherein center portions of the first aperture pattern and the second aperture pattern are substantially straight and formed alternately in parallel, and wherein the spacers are positioned at ends of the second aperture pattern.

(21) Appl. No.: **11/788,486**

(22) Filed: **Apr. 19, 2007**

Related U.S. Application Data

(63) Continuation of application No. 09/970,994, filed on Oct. 5, 2001, now Pat. No. 7,209,204.

(30) **Foreign Application Priority Data**

Jan. 12, 2001 (KR)..... 2001-001791

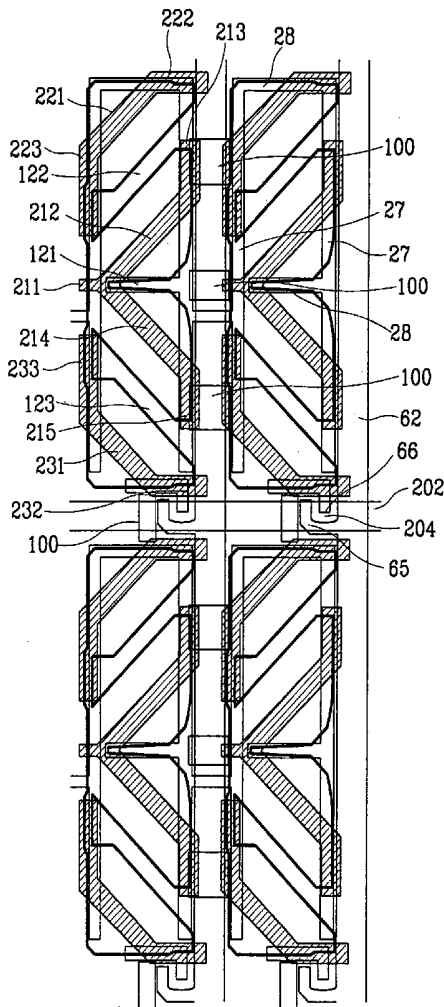

FIG. 1

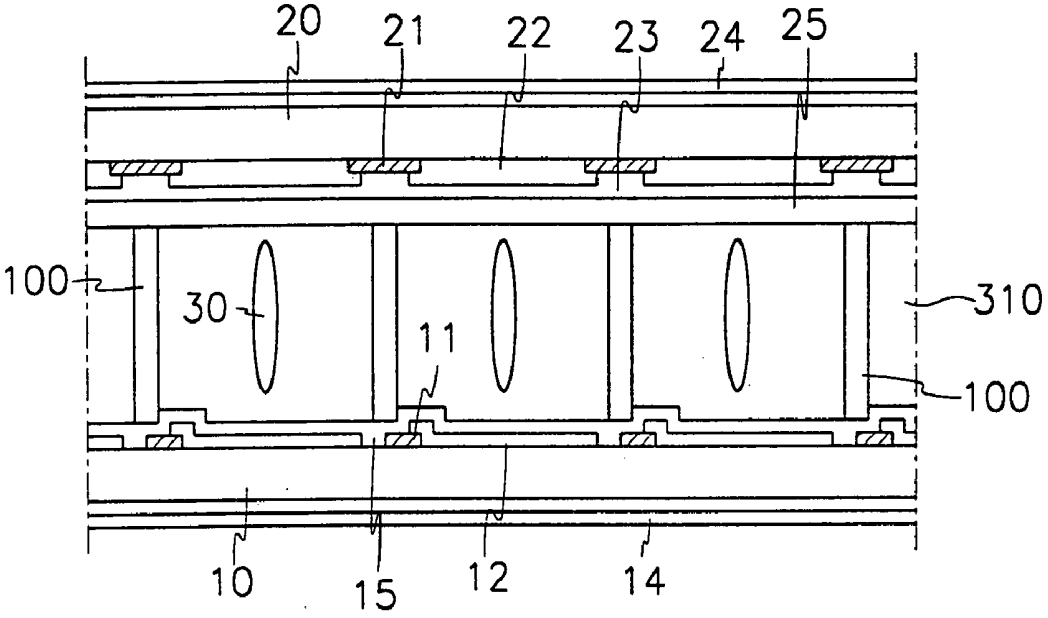

FIG. 2

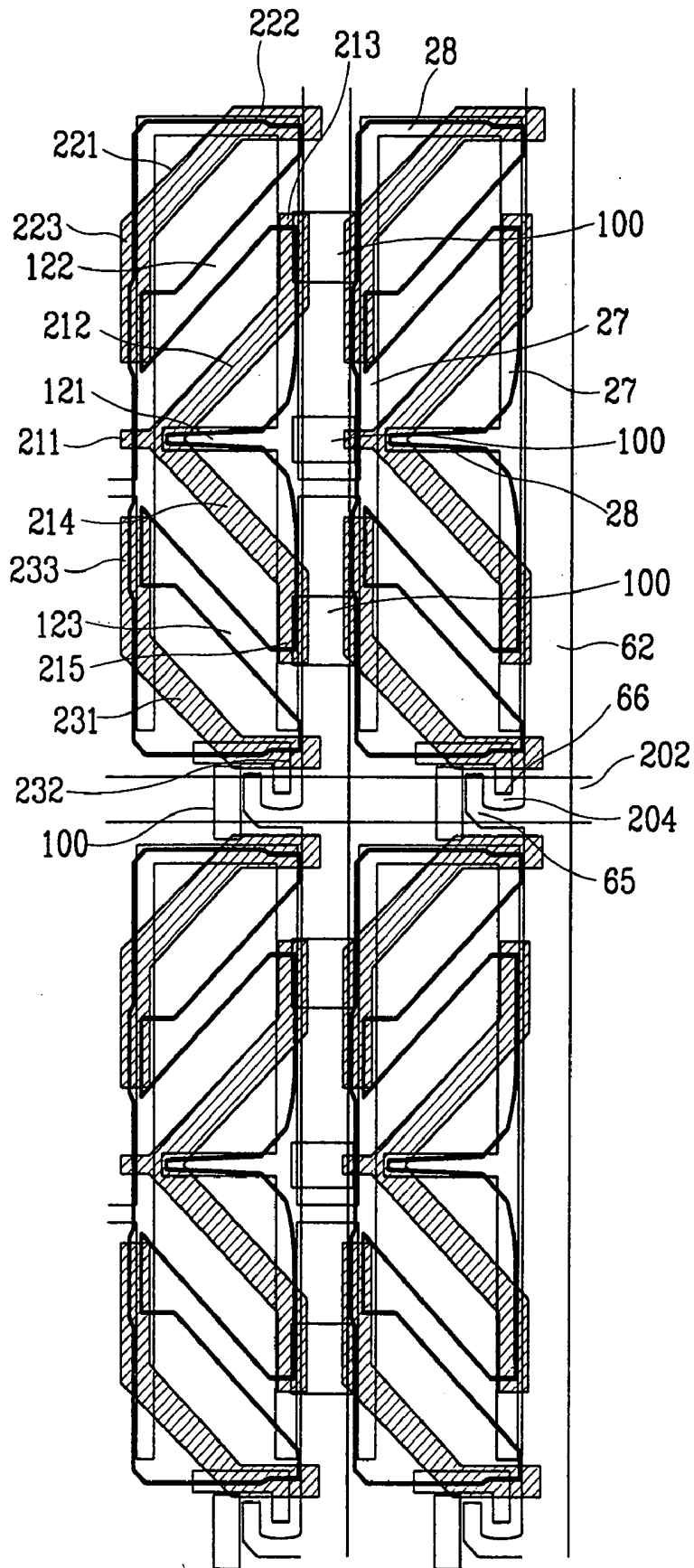
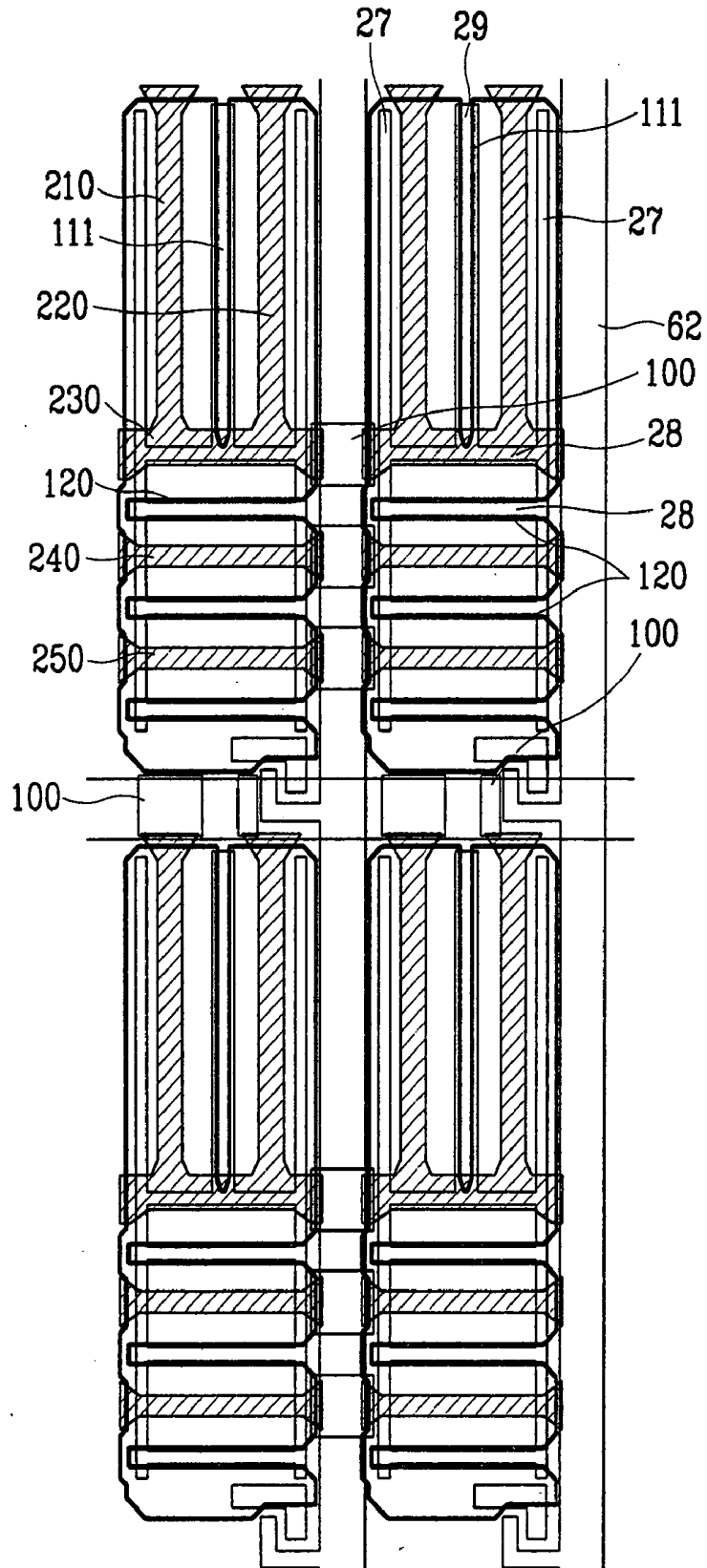

FIG. 3



LIQUID CRYSTAL DISPLAY HAVING WIDE VIEWING ANGLE

BACKGROUND OF THE INVENTION

[0001] (a) Field of the Invention

[0002] The present invention relates to a liquid crystal display having a wide viewing angle, and more particularly, to a liquid crystal display in which a predetermined pattern is formed on common electrodes and pixel electrodes to obtain a wide viewing angle.

[0003] (b) Description of the Related Art

[0004] A liquid crystal display (LCD) is structured having liquid crystal material injected between an upper substrate, on which common electrodes and a color filter are formed, and a lower substrate, on which thin film transistors and pixel electrodes are formed. Voltages of different potentials are applied to the pixel electrodes and common electrodes to form an electric field, thereby varying the alignment of liquid crystal molecules of the liquid crystal material. In this way, the transmittance of incident light is controlled to enable the display of images.

[0005] In a vertically aligned (VA) LCD, long axes of the liquid crystal molecules align themselves vertically to the substrates in a state where no electric field is formed between the substrates. Accordingly, using polarizing plates, light is completely blocked when there is no electric field. That is, in a normally black mode, since brightness of an off state is extremely low, a higher contrast ratio than obtained in a twisted nematic LCD is realized.

[0006] When an electric field is formed, however, since the slanting direction of the liquid crystal molecules is irregular, there exist areas where a polarizing direction of polarizing plates of the upper and lower substrates corresponds to the direction of the long axes of the liquid crystal molecules. In these areas, the liquid crystal molecules cannot rotate the polarizing direction of light such that the light is cut off by the polarizing plates. This results in dark areas on the screen, which is referred to as texture. Accordingly, it becomes necessary to pattern the electrodes.

[0007] Further, permanent damage to brightness may occur in the vertically aligned LCD if the display receives outside shock. That is, outside shock to the LCD may significantly alter a thickness of a liquid crystal cell is significantly altered as a result of the elastic properties of spacers used to maintain a cell gap between the substrates. Hence, the screen becomes spotted.

SUMMARY OF THE INVENTION

[0008] The present invention has been made in an effort to solve the above problems.

[0009] It is an object of the present invention to provide a liquid crystal display having a wide viewing angle, which improves picture quality and reduces brightness variations.

[0010] To achieve the above object, the present invention provides a liquid crystal display comprising a first substrate, pixel electrodes formed on the first substrate, and having a first aperture pattern, a second substrate provided opposing the first substrate, a common electrode formed on the second substrate having a second aperture pattern, liquid crystal

material injected between the first and second substrates, and spacers provided between the first and second substrates for maintaining a predetermined gap between the first and second substrates, wherein center portions of the first aperture pattern and the second aperture pattern are substantially straight and formed alternately in parallel, and wherein the spacers are positioned at ends of the second aperture pattern.

[0011] According to a feature of the present invention, the first aperture pattern includes a first aperture formed in a first direction in an upper region of the pixel electrodes, and a second aperture formed in a lower region of the pixel electrodes in a second direction, which forms a right angle with the first direction, and the second aperture pattern includes a first base aperture formed in the first direction at a position corresponding to the upper region of the pixel electrodes, and a second base aperture formed in the second direction at a position corresponding to the lower region of the pixel electrodes.

[0012] According to another feature of the present invention, the first direction forms an oblique angle with edges of the pixel electrodes.

[0013] According to yet another feature of the present invention, the second aperture pattern includes a first branch aperture that overlaps upper and lower edges of the pixel electrodes, and a second branch aperture that overlaps left and right edges of the pixel electrodes the first aperture pattern includes third apertures positioned at upper and lower center portions of the pixel electrodes uniformly provided with respect to the upper and lower edges of the pixel electrodes and the first and second aperture patterns divide the pixel electrodes into a plurality of closed polygonal shapes.

[0014] According to still yet another feature of the present invention, the second branch aperture than the base apertures.

[0015] According to still yet another feature of the present invention, the first direction is formed uniformly with one edge of the pixel electrodes.

[0016] In another aspect, the present invention provides a liquid crystal display comprising a first substrate pixel electrodes formed on the first substrate having a first aperture pattern, a second substrate provided opposing the first substrate, a common electrode formed on the second substrate formed thereon a second aperture pattern, liquid crystal material injected between the first and second substrates, and spacers provided between the first and second substrates for maintaining a predetermined gap between the first and second substrates, wherein the first aperture pattern includes a first aperture formed horizontally from a first side of the pixel electrodes, and second and third apertures formed obliquely from the first aperture and symmetrically about the first aperture, and formed such that an interval between the second and third apertures decreases as a second side of the pixel electrodes, which is opposite the first side, is approached, wherein the second aperture pattern includes (a) a base portion formed horizontally, (b) a fourth aperture having first and second branches formed obliquely from the base portion such that a distance between the first and second branches increases in a direction away from the base portion, and having first and second branch ends formed vertically in opposite directions from distal ends

respectively of the first and second branches, (c) a fifth aperture having a first center portion formed substantially in parallel with the first branch, and having first and second bends forming horizontal and vertical portions, and (d) a sixth aperture formed symmetrically with the fifth aperture about the fourth aperture, wherein the first and second aperture patterns are formed alternately when the liquid crystal display is viewed from above, and wherein the spacers are provided at ends of the second aperture pattern.

[0017] In yet another aspect, the present invention provides a liquid crystal display comprising a first substrate, pixel electrodes formed on the first substrate having a first aperture pattern, a second substrate provided opposing the first substrate, a common electrode formed on the second substrate having a second aperture pattern, and liquid crystal material injected between the first and second substrates, wherein the first aperture pattern includes first apertures dividing an upper portion of the pixel electrodes into vertical regions, and second apertures formed below the first apertures to divide a lower portion of the pixel electrodes into horizontal regions, wherein the second aperture pattern includes third apertures formed vertically, and fourth apertures formed horizontally below the third apertures, and wherein the first apertures and the third apertures are alternately formed to divide the upper portion of the pixel electrodes into a plurality of regions, and the second apertures and fourth apertures are alternately formed to divide the lower portion of the pixel electrodes into a plurality of regions.

BRIEF DESCRIPTION OF THE DRAWINGS

[0018] The accompanying drawings, which are incorporated in and constitute a part of the specification, illustrate an embodiment of the invention, and, together with the description, serve to explain the principles of the invention.

[0019] FIG. 1 is a schematic sectional view of a portion of a liquid crystal display according to a preferred embodiment of the present invention.

[0020] FIGS. 2 and 3 are schematic plan views of an aperture pattern formed on upper and lower substrates of an LCD, and spacers provided between the substrates, according to first and second preferred embodiments, respectively, of the present invention.

DETAILED DESCRIPTION OF THE PREFERRED EMBODIMENTS

[0021] Preferred embodiments of the present invention will now be described in detail with reference to the accompanying drawings.

[0022] FIG. 1 shows a schematic sectional view of a portion of a liquid crystal display according to a preferred embodiment of the present invention.

[0023] The liquid crystal display includes a first (lower) substrate 10 and a second (upper) substrate 20, which are provided substantially in parallel with a predetermined gap therebetween, a liquid crystal layer 310 formed of liquid crystal material between the substrates 10 and 20, and comprised of liquid crystal molecules 30 that are aligned perpendicular to the substrates 10 and 20, and spacers 100 provided between the substrates 10 and 20, the spacers 100 maintaining a predetermined gap between the substrates 10 and 20.

[0024] Pixel electrodes 12 are formed on the first substrate 10, the first substrate 10 being made of a transparent insulating material. The pixel electrodes 12 are made of a transparent conducting material such as ITO (indium tin oxide) or IZO (indium zinc oxide), and have an aperture pattern (not shown) formed thereon. Each pixel electrode 12 is connected to a switching element 11 to receive an image signal voltage. A thin film transistor is generally used for the switching elements 11. Each thin film transistor is connected to a gate line (not shown), which transmits scanning signals, and to a data line (not shown), which transmits image signals. The thin film transistors turn the pixel electrodes 12 on and off according to the scanning signals. Further, an orientation layer 15 for orienting the liquid crystal molecules 30 is also formed on the first substrate 10. Finally, a lower polarizing plate 14 is provided on an outer surface of the first substrate 10. In a reflective-type LCD, it is not necessary that the pixel electrodes 12 be made of a transparent material, nor is it necessary to attach the lower polarizing plate 14 to the first substrate 10.

[0025] Formed on the second substrate 20, which is made of a transparent insulating material like the first substrate 10, are a black matrix 21 for preventing light leakage; a red, green, blue color filter 22 a common electrode 23 made of a transparent conducting material such as ITO and IZO, and having an aperture pattern (not shown) formed thereon; and an orientation layer 25 for orienting the liquid crystal molecules of the liquid crystal layer 310. It is possible for the black matrix 21 or the color filter 22 to be formed on the first substrate. There is also provided an upper polarizing plate 24 on an outer surface of the second substrate 20.

[0026] The lower and upper polarizing plates 14 and 24 are arranged such that their polarizing directions are perpendicular to each other in the normally black mode, and in the normally white mode, the polarizing directions are parallel. The following description will be about the normally black mode.

[0027] FIG. 2 shows a schematic plan view of an aperture pattern formed on first and second substrates, and spacers provided between the substrates, according to a first preferred embodiment of the present invention. The drawing depicts the substrates in a combined state, that is, in a state where the second substrate is provided opposing the first substrate with a predetermined gap therebetween.

[0028] Formed on the first substrate is gate wiring, which includes gate lines 202 for transmitting scanning signals and gate signals, and gate electrodes 204 of thin film transistors, which are connected to the gate lines 202. Also formed on the first substrate is data wiring. The data wiring includes data lines 62 intersecting the gate lines 202 to define unit pixels, the data lines 62 transmitting data signals; source electrodes 65 of the thin film transistors, which are connected to the data lines 62; and drain electrodes 66 of the thin film transistors, which oppose the source electrodes 65 centered about the gate electrodes 204. Here, the pixel electrodes 12 and the drain electrodes 66 are electrically connected such that the pixel electrodes 12 receive data signals from the data wiring 62, 65 and 66. Further, storage wiring 27 and 28 is formed on a circumference of the unit pixels, the storage wiring 27 and 28 overlapping the pixel electrodes 12 to form a storage capacitance, and preventing the leakage of light through the edges of the unit pixel.

[0029] A first aperture 121 is formed in each pixel electrode 12. The first apertures 121 penetrate through a center portion of the pixel electrodes 12 starting from a right side thereof (in the drawing), and extend almost the entire width of the pixel electrodes 12 to divide the pixel electrodes 12 into an upper half and a lower half. The first apertures 121 are wide where they begin (their "openings") on the right side of the pixel electrodes 12 then taper at two different predetermined angles to a predetermined width, after which the first apertures 121 continue at this width for the remainder of their length. Further, second and third apertures 122 and 123 are formed respectively in the upper and lower half of each pixel electrode 12. The second and third apertures 122 and 123 are symmetrical about the first apertures 121, and are formed starting from the right side of the pixel electrodes 12 and extend to a left side (in the drawing) of the same at a predetermined angle. The left sides of the pixel electrodes 12 where the second and third apertures 122 and 123 end are protruded outwardly to prevent connection defects caused by the second and third apertures 122 and 123.

[0030] A fourth aperture is formed in each unit pixel of the common electrode 23, which is continuously formed over an entire surface of the second substrate. The fourth aperture includes an apex 211 formed in a horizontal direction (in the drawing), first and second branches 212 and 214 obliquely formed from the apex 211 extending respectively upwardly and downwardly, and first and second branch ends 213 and 215 extending vertically from distal ends of the first and second branches 212 and 214. Further, a fifth aperture is formed above (in the drawing) the fourth apertures. The fifth apertures include a center portion 221 extending from one edge of the unit pixel to an adjacent edge at an angle identical to the first branch 212, a horizontal portion 222 extending in the horizontal direction from the center portion 221, and a vertical portion 223 extending in the vertical direction from the center portion 221. Sixth apertures including center, horizontal and vertical portions 231, 232 and 233 are formed symmetrically with the fifth apertures on the opposite side of the fourth apertures. The fourth, fifth and sixth apertures are formed in the same manner in each unit pixel of the common electrode 23.

[0031] As shown in FIG. 2, portions of the first, second and third apertures 121, 122 and 123 of the pixel electrodes 12 overlap portions of the fourth, fifth and sixth apertures of the common electrode 23 to divide the pixel electrode into a plurality of regions. The center portion 221 of the fifth aperture, the second aperture 122, the first branch 212 of the fourth aperture, the second branch 214 of the fourth aperture, the third aperture 123, and the center portion 231 of the sixth aperture are provided in parallel in an alternating manner.

[0032] As a result of the above aperture configuration, the liquid crystal molecules, which are re-aligned following the formation of an electric field between the substrates, are slanted in four different directions in each pixel region according to the fringe field formed as a result of the apertures.

[0033] Provided at ends of the elements 211, 213, 215, 222, 232 and 233 of the apertures of the common electrode 23 are spacers 100. The spacers are made of an organic material and act to maintain a uniform gap between the

substrates. With this configuration, directors of the liquid crystal molecules at ends of the elements 211, 213, 215, 222, 232 and 233 of the apertures are not aligned in various directions preventing disclination. That is, when a drive voltage is applied to the pixel electrodes 12 and the common electrode 23 to control the liquid crystal molecules, the electric field at ends of the elements 211, 213, 215, 222, 232 and 233 is not uniformly formed and a slanting of the electric field significantly varies. This causes the non-uniform alignment of the liquid crystal molecules. By providing the organic spacers 100 at these locations, disclination is prevented. In addition, the spacers 100 are able to securely maintain the gap between the substrates even when outside shocks are applied to the LCD, in which prevents brightness reduction caused by changes in the gap.

[0034] The above aperture patterns can take various shapes to dividedly align the liquid crystal molecules. However, it is preferable that the following conditions be satisfied.

[0035] (i) It is preferable that a single pixel region is divided into four in order to realize a wide viewing angle.

[0036] (ii) In order to realize a stable divided alignment of the liquid crystal molecules, neither disclination nor texture should occur outside the borders of the divided small regions. With disclination, the directors of the liquid crystal molecules may assume various directions rather than a uniform direction in a small region. Hence, the liquid crystals are slanted so that they contact one another in a single pixel region. It is therefore preferable that the patterns of the first and second substrates are repeated to realize a stable divided alignment, and that the patterns of the first and second substrates are formed as close together as possible. Stated differently, when viewing the apertures in a combined state from above (top sectional view), it is preferable that the regions formed by the patterns of the first and second substrates assume closed polygonal shapes. Further, since disclination can easily occur if an acute angle is formed in the patterns to define one region, it is preferable that only obtuse angles be formed in the patterns. A stable divided alignment is also necessary to obtain good brightness characteristics. In a region with a scattered alignment, light appears brighter in an off state and some portions are darker than other portions result in an on state. The scattered alignment regions change location during liquid crystal molecule alignment and generate afterimages.

[0037] (iii) This following condition must be satisfied in order to obtain a high brightness. First, it is preferable that the liquid crystal directors of adjacent regions meet each other at 90 degree angle. By meeting this criterion, disclination occurs only at the narrowest region. Also, an angle between a transmission axis of the polarizing plate and the liquid crystal directors is 45 degrees can achieve the highest brightness. Further, it is preferable that bending or angling of the angles made by the apertures of the first and second substrates be reduced as much as possible.

[0038] (iv) To obtain a good response speed, the above condition to better obtain brightness by minimizing bending or angling of the angles made by the apertures of the first and second substrates must be satisfied.

[0039] FIG. 3 shows a schematic plan view of an aperture pattern formed on first and second substrates, and spacers

provided between the substrates, according to a second preferred embodiment of the present invention. The drawing depicts the substrates in a combined state, that is, in a state where the second substrate is provided opposing the first substrate with a predetermined gap therebetween.

[0040] Storage wiring **27**, **28** and **29** occupies edges of unit pixels and is formed corresponding to an aperture pattern of the pixel electrodes **12**. The aperture pattern of the pixel electrodes **12** includes a first aperture **111** that divides an upper portion (in the drawing) of the pixel electrodes **12** into left and right (in the drawing) halves, and a second aperture **120** that divides a lower portion (in the drawing) of the pixel electrodes **12** into four portions. Further, a third aperture is formed in the common electrode **23** of each unit pixel. The third aperture includes a horizontal portion **230** formed substantially in a center area of each pixel region to divide the common electrode **23** of a unit pixel into upper and lower portions (in the drawing), and first and second vertical portions **210** and **220** extending from the horizontal portion **230** across the upper portion of the common electrode **23** of a unit pixel. Formed horizontally (in the drawing) in the lower portion of the common electrode **23** of a unit pixel are fourth and fifth apertures **240** and **250**. Unconnected ends of the elements **210**, **220**, **230**, **240** and **250** expand into triangular shapes.

[0041] As shown in FIG. 3, the first aperture **111** of the pixel electrodes **12** and the first and second vertical portions **210** and **220** of the common electrode **23** in each unit pixel are alternately formed in parallel such that the upper portions of the pixel electrodes **12** are divided into four substantially equal vertical regions. Further, the second apertures **120**, the horizontal portion **230** of the third aperture, the fourth aperture **240**, and the fifth aperture **250** are alternately formed in parallel in a horizontal direction starting from the center of the pixel regions and extending downward to the lower portion of the pixel regions. Accordingly, the pixel electrodes **12** are divided into six substantially equal regions.

[0042] In addition, provided at ends of the elements **210**, **220**, **230**, **240** and **250** of the apertures of the common electrode **23** are spacers **100**. The spacers **100** are made of an organic material, act to maintain a uniform gap between

the substrates, and otherwise provide the same benefits as outlined with respect to the first preferred embodiment.

[0043] Although preferred embodiments of the present invention have been described in detail hereinabove, it should be clearly understood that many variations and/or modifications of the basic inventive concepts herein taught which may appear to those skilled in the present art will still fall within the spirit and scope of the present invention, as defined in the appended claims.

[0044] For example, although aperture patterns are formed in the common electrode and the pixel electrodes in the above embodiments, it is possible to form both an aperture pattern and protrusions only in the pixel electrodes. In this case, the protrusions can be formed, for example, out of the gate insulating layer or the protection layer. When protrusions are formed, care must be taken to prevent the parasitic capacitance in the spaces between the wiring. As another example, an aperture pattern may be formed in the pixel electrodes and protrusions in the common electrode.

What is claimed is:

1. A liquid crystal display, comprising:

a first substrate;

pixel electrodes formed on the first substrate and having a first aperture pattern;

a second substrate provided opposing the first substrate;

a common electrode formed on the second substrate and having a second aperture pattern;

liquid crystal material injected between the first substrate and the second substrate; and

spacers provided between the first substrate and the second substrate for maintaining a predetermined gap between the first substrate and the second substrate,

wherein center portions of the first aperture pattern and the second aperture pattern are substantially straight and formed alternately in parallel, and wherein the spacers are positioned at ends of the second aperture pattern.

* * * * *

专利名称(译)	具有宽视角的液晶显示器		
公开(公告)号	US20070195249A1	公开(公告)日	2007-08-23
申请号	US11/788486	申请日	2007-04-19
[标]申请(专利权)人(译)	MUN JOONG HYUN SONG JANG KUN		
申请(专利权)人(译)	MUN JOONG-HYUN SONG JANG-KUN		
当前申请(专利权)人(译)	三星DISPLAY CO. , LTD.		
[标]发明人	MUN JOONG HYUN SONG JANG KUN		
发明人	MUN, JOONG-HYUN SONG, JANG-KUN		
IPC分类号	G02F1/1343 G02F1/1337 G02F1/1339		
CPC分类号	G02F1/133707 G02F1/13394 G02F2201/122 G02F1/134336 G02F2001/134318 G02F1/134309		
优先权	1020010001791 2001-01-12 KR 1020000069723 2000-11-22 KR		
其他公开文献	US7564526		
外部链接	Espacenet USPTO		

摘要(译)

公开了一种包括第一基板的液晶显示器;像素电极形成在第一基板上,像素电极上形成有第一开口图案;与第一基板相对设置的第二基板;形成在第二基板上的公共电极,公共电极上形成有第二孔图案;注入第一和第二基板之间的液晶材料;在第一和第二基板之间提供间隔物,用于保持第一和第二基板之间的预定间隙,其中第一孔图案和第二孔图案的中心部分基本上是直的并且交替地平行形成,并且其中间隔物位于第二孔图案的末端。

