



(19) **United States**

(12) **Patent Application Publication**

Shen et al.

(10) **Pub. No.: US 2004/0201560 A1**

(43) **Pub. Date:**

Oct. 14, 2004

(54) **METHOD FOR DRIVING TRANSFLECTIVE LIQUID CRYSTAL DISPLAY**

Publication Classification

(75) Inventors: **Yuh-Ren Shen, Tainan (TW);
Ching-Yih Chen, Miaoli (TW)**

(51) **Int. Cl.⁷** **G09G 3/36**

(52) **U.S. Cl.** **345/87**

Correspondence Address:
**QUINTERO LAW OFFICE
1617 BROADWAY, 3RD FLOOR
SANTA MONICA, CA 90404 (US)**

(57) **ABSTRACT**

A method for driving a transreflective LCD. In the present invention, the transreflective LCD has a plurality of pixels arranged in a matrix, and each pixel includes a reflective cell and a transmission cell. The reflective cell and transmission cells are driven by different transistors. In the method of the present invention, all the first switching devices are turned on and the first driving voltages are then applied to the reflective cells in turn. After that, all the second switching devices are turned on and the second driving voltages are then applied to the transmission cells in turn. The first driving voltages are applied to the reflective cells in turn and the second driving voltages are applied to the transmission cells in turn in one frame period.

(73) Assignee: **Industrial Technology Research Institute**

(21) Appl. No.: **10/643,186**

(22) Filed: **Aug. 18, 2003**

(30) **Foreign Application Priority Data**

Apr. 9, 2003 (TW)..... 92108095

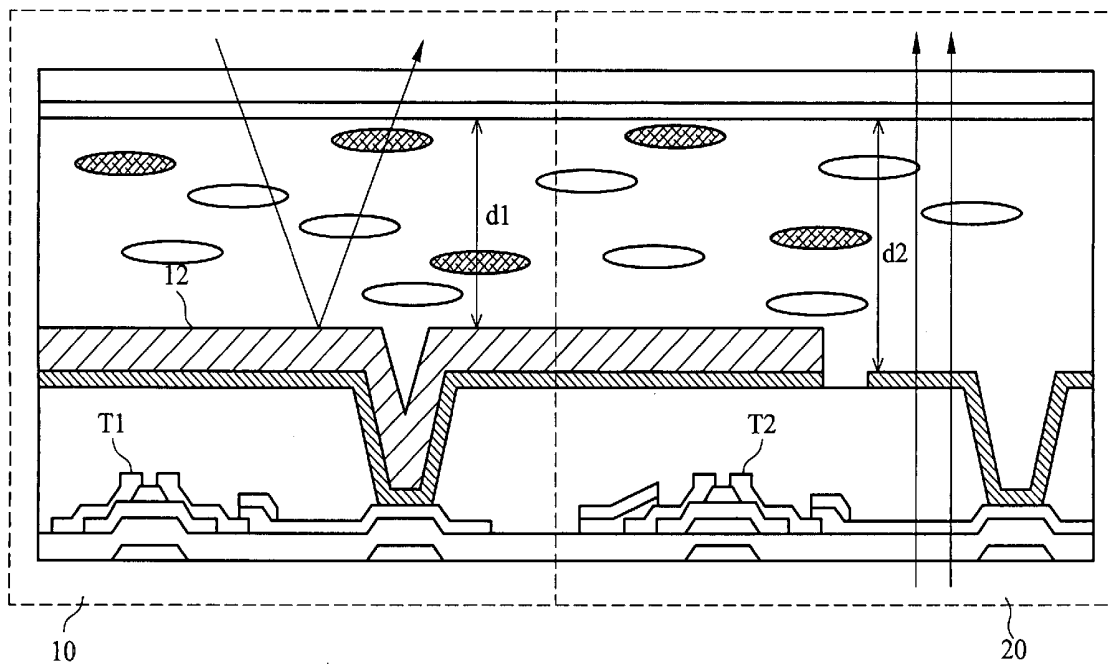

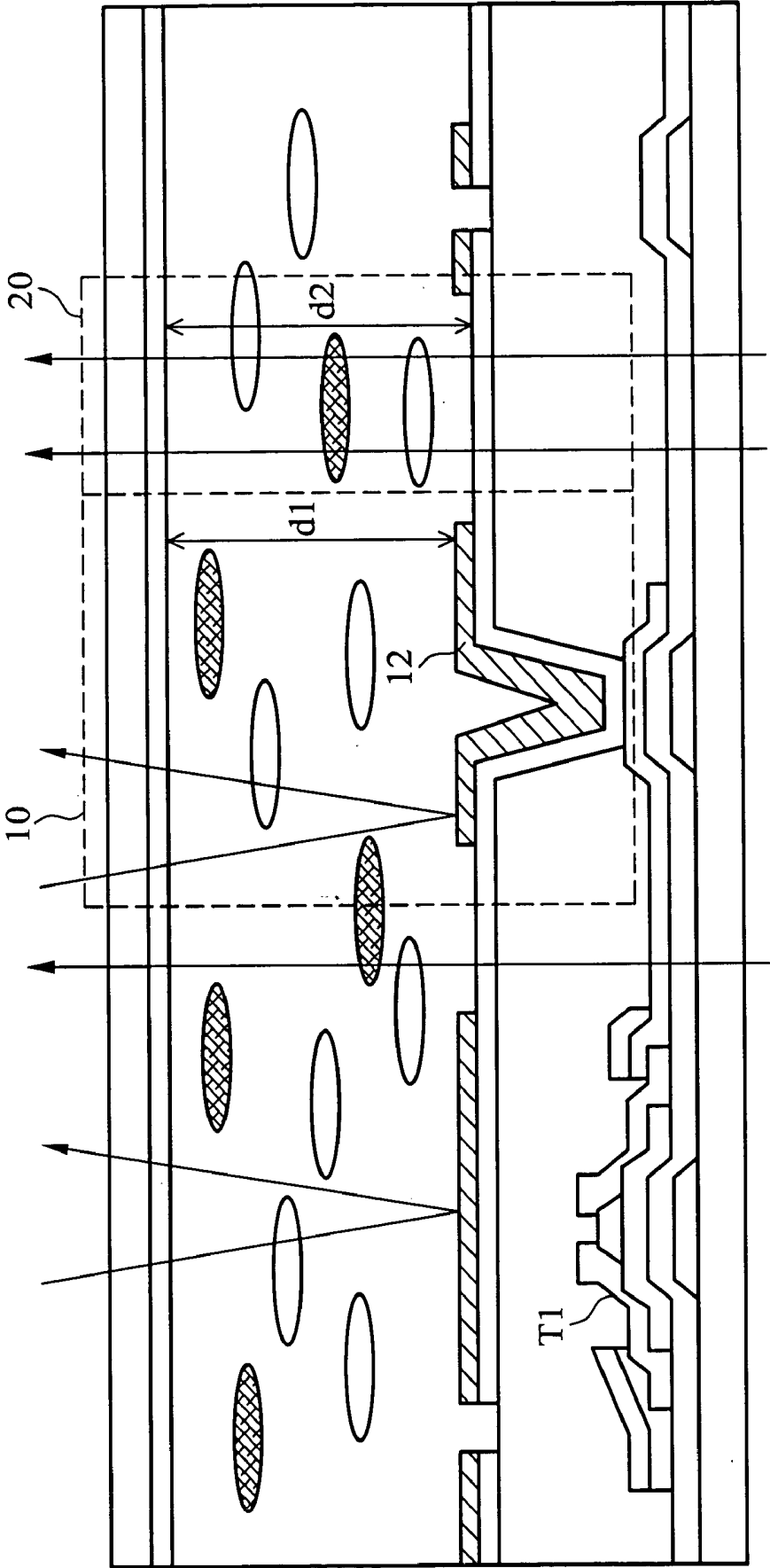

FIG. 1A (PRIOR ART)

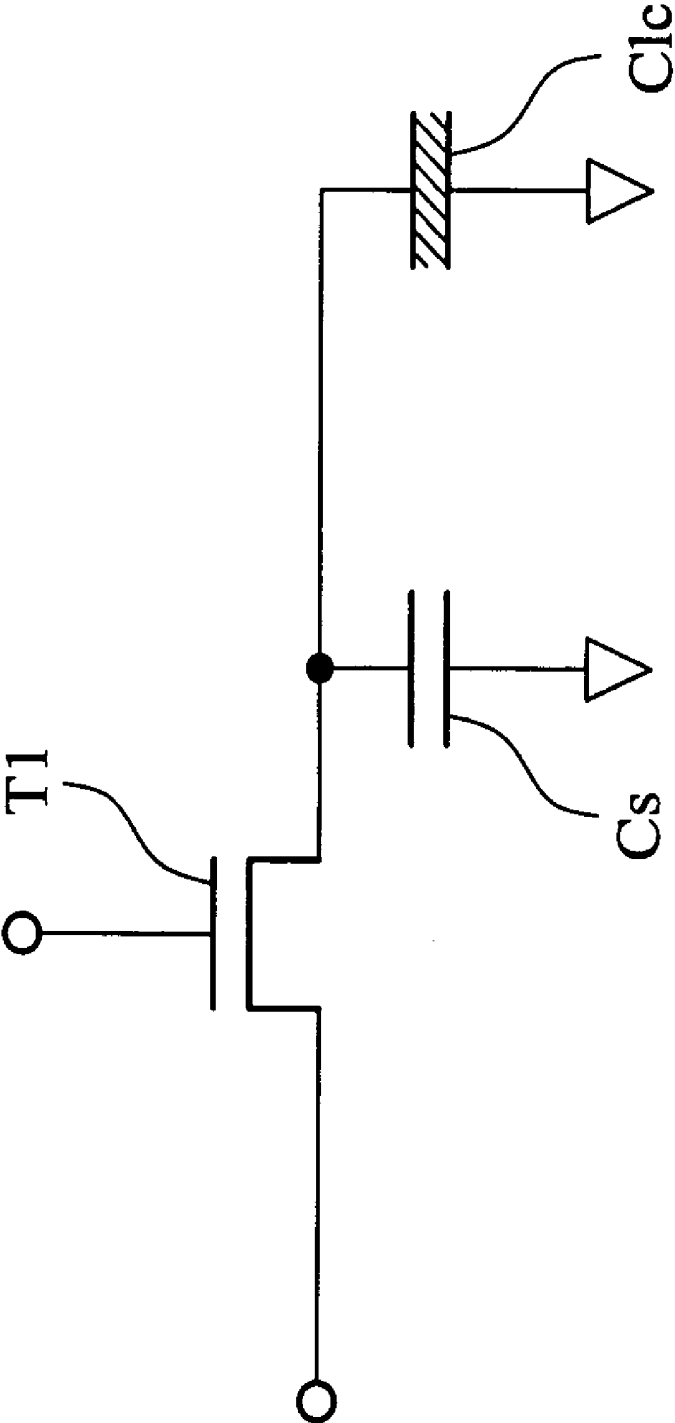

FIG. 1B (PRIOR ART)

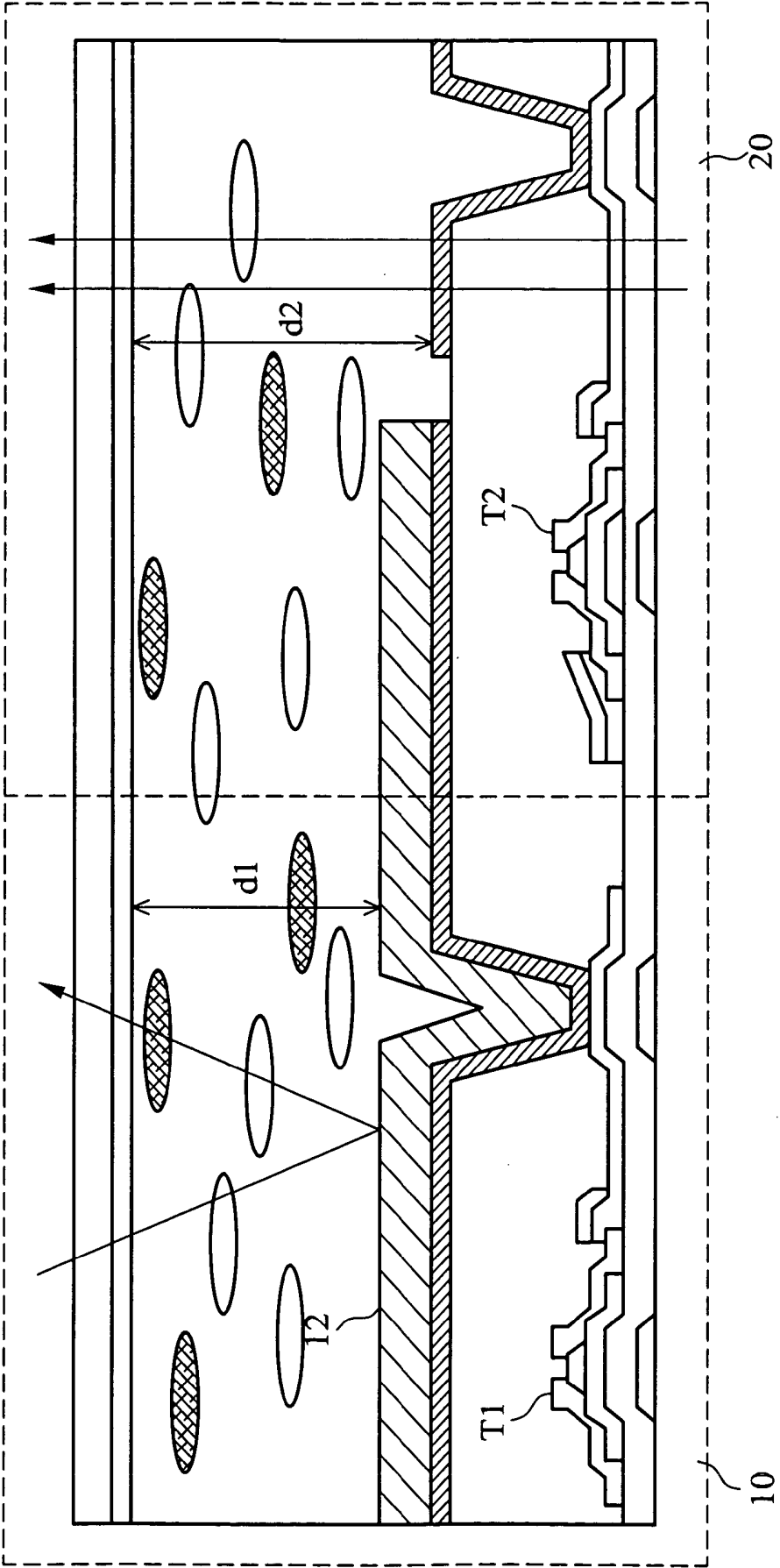

FIG. 2A

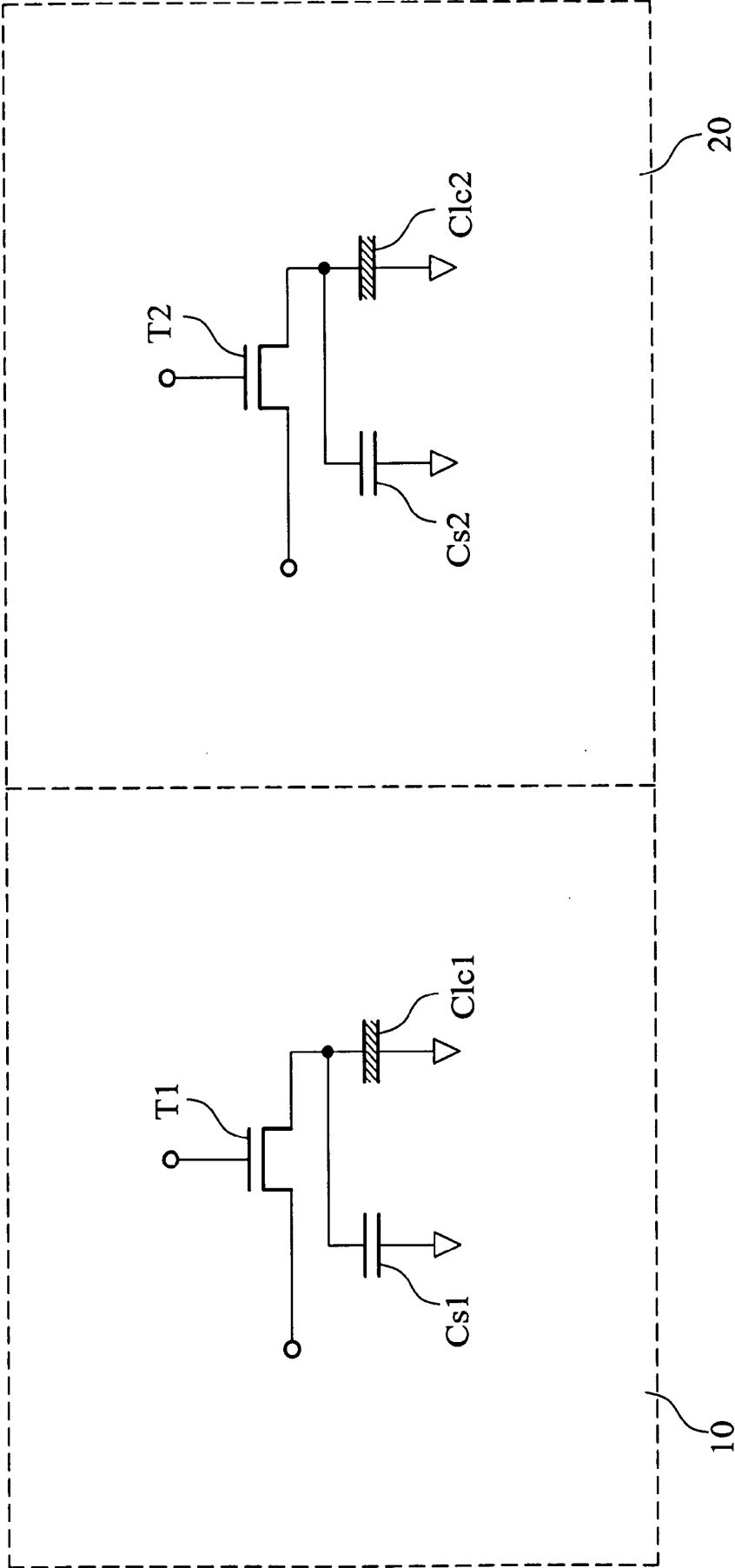

FIG. 2B

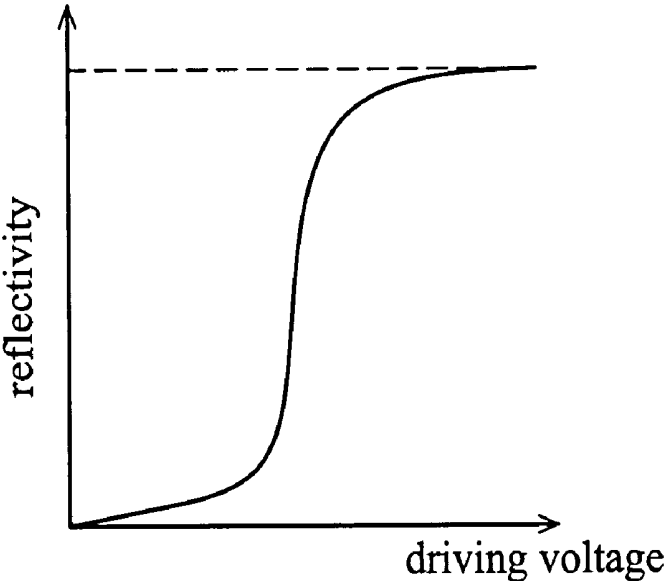

FIG. 3A

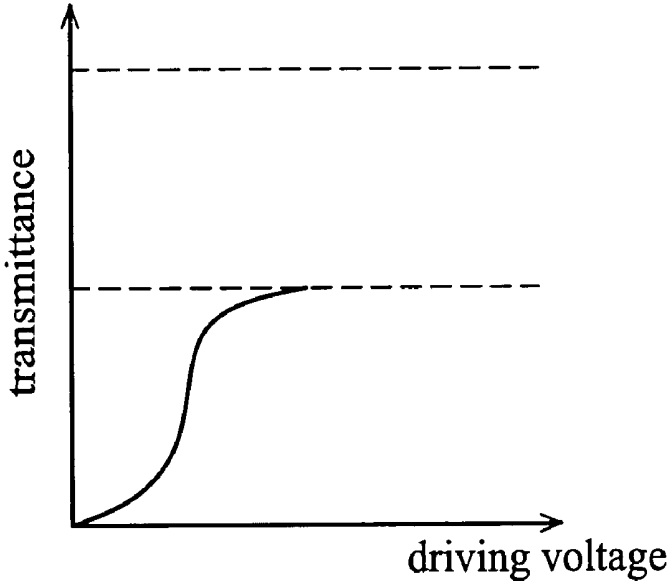

FIG. 3B

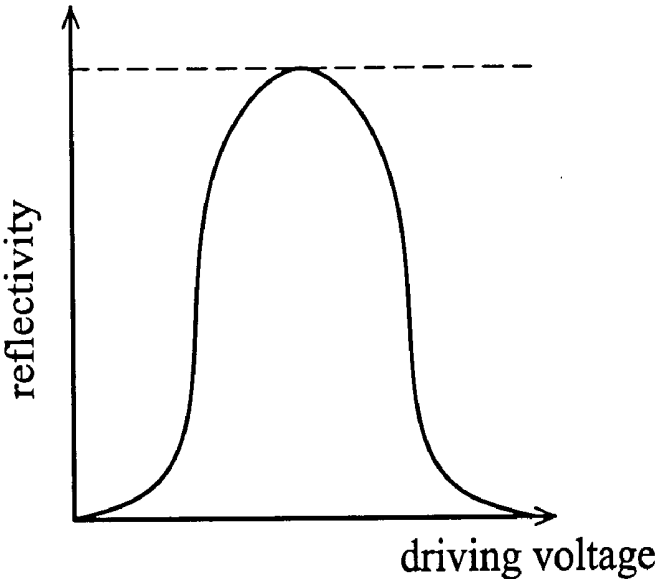

FIG. 3C

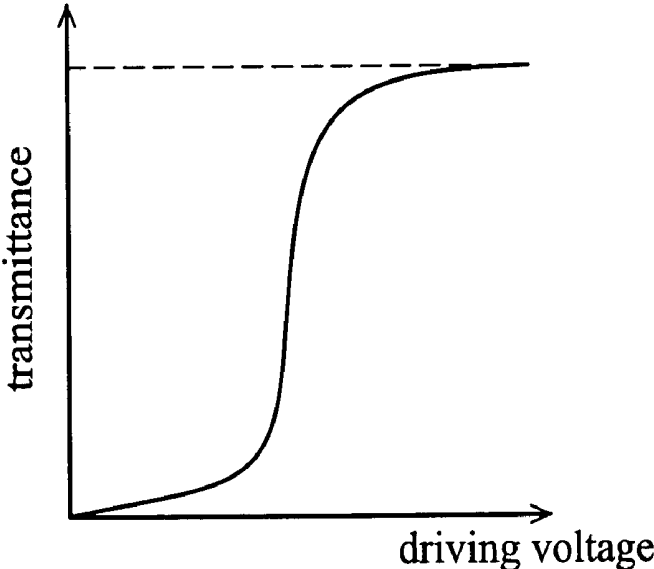

FIG. 3D

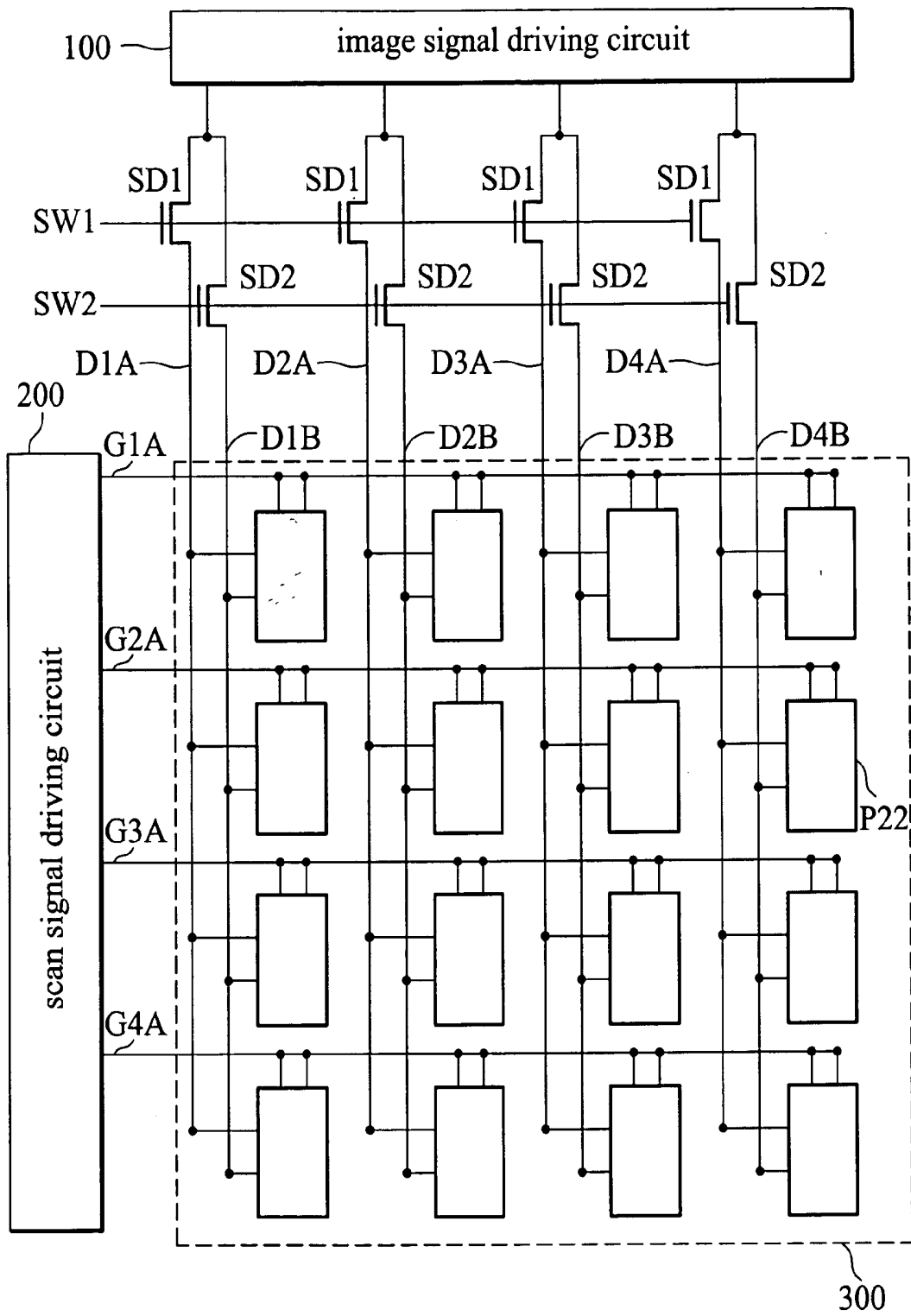

FIG. 4A

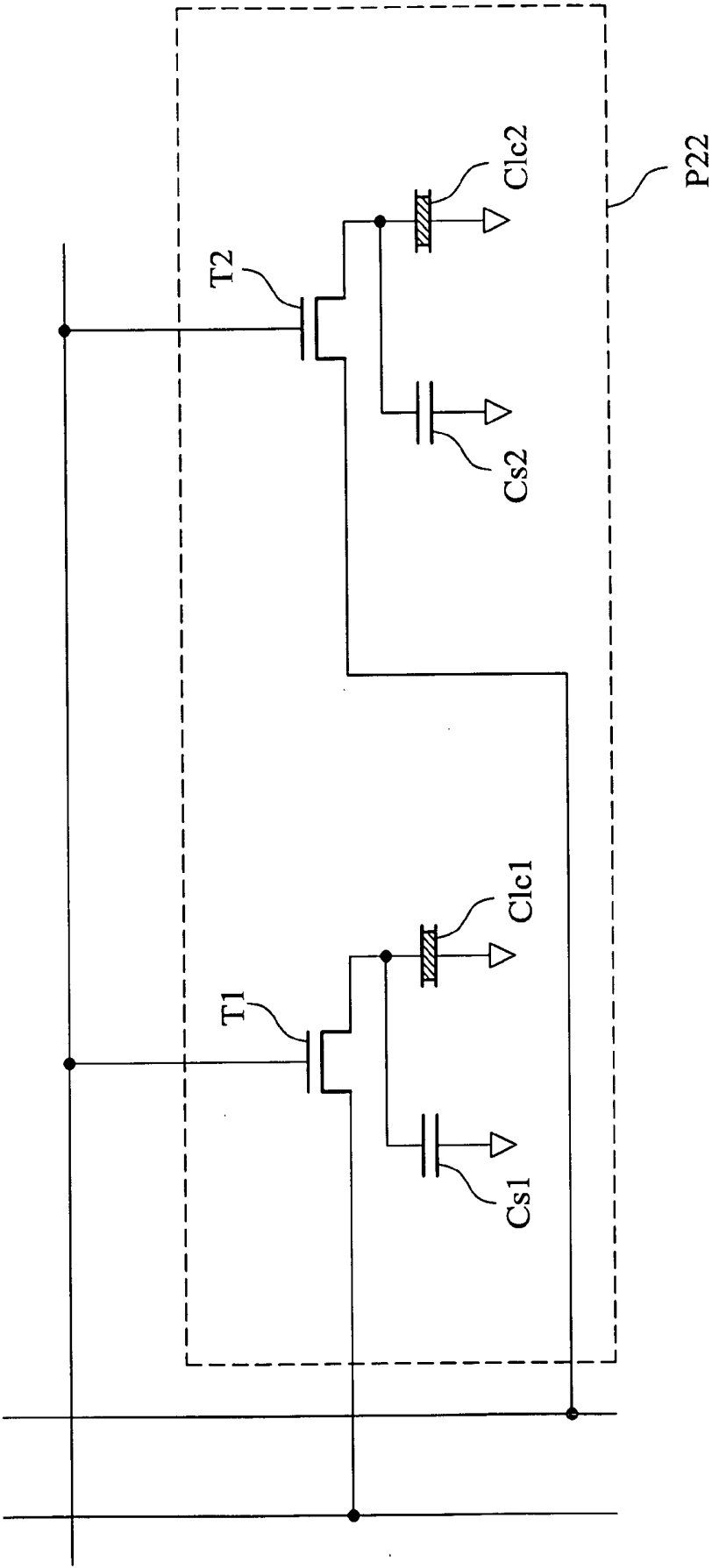

FIG. 4B

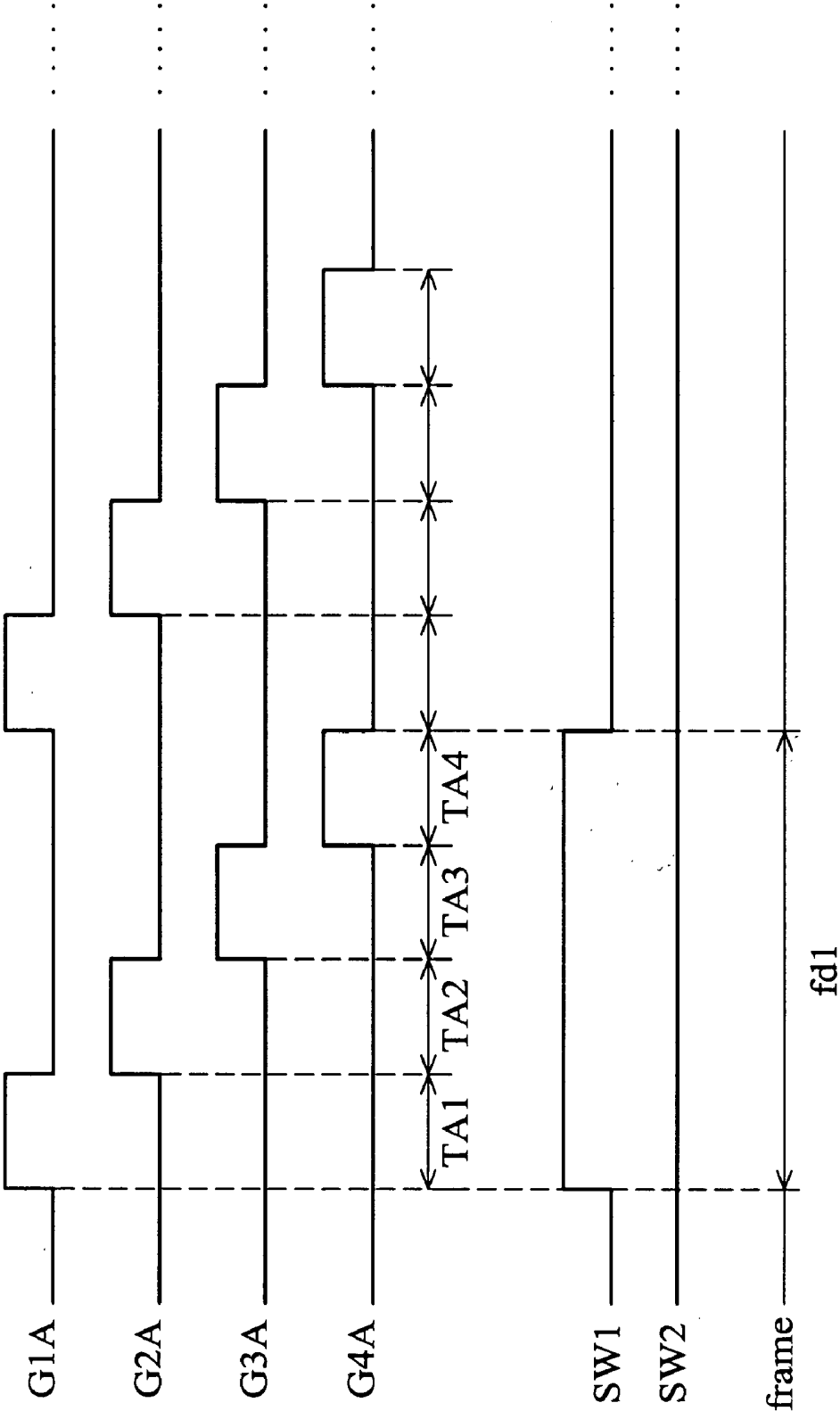

FIG. 5A

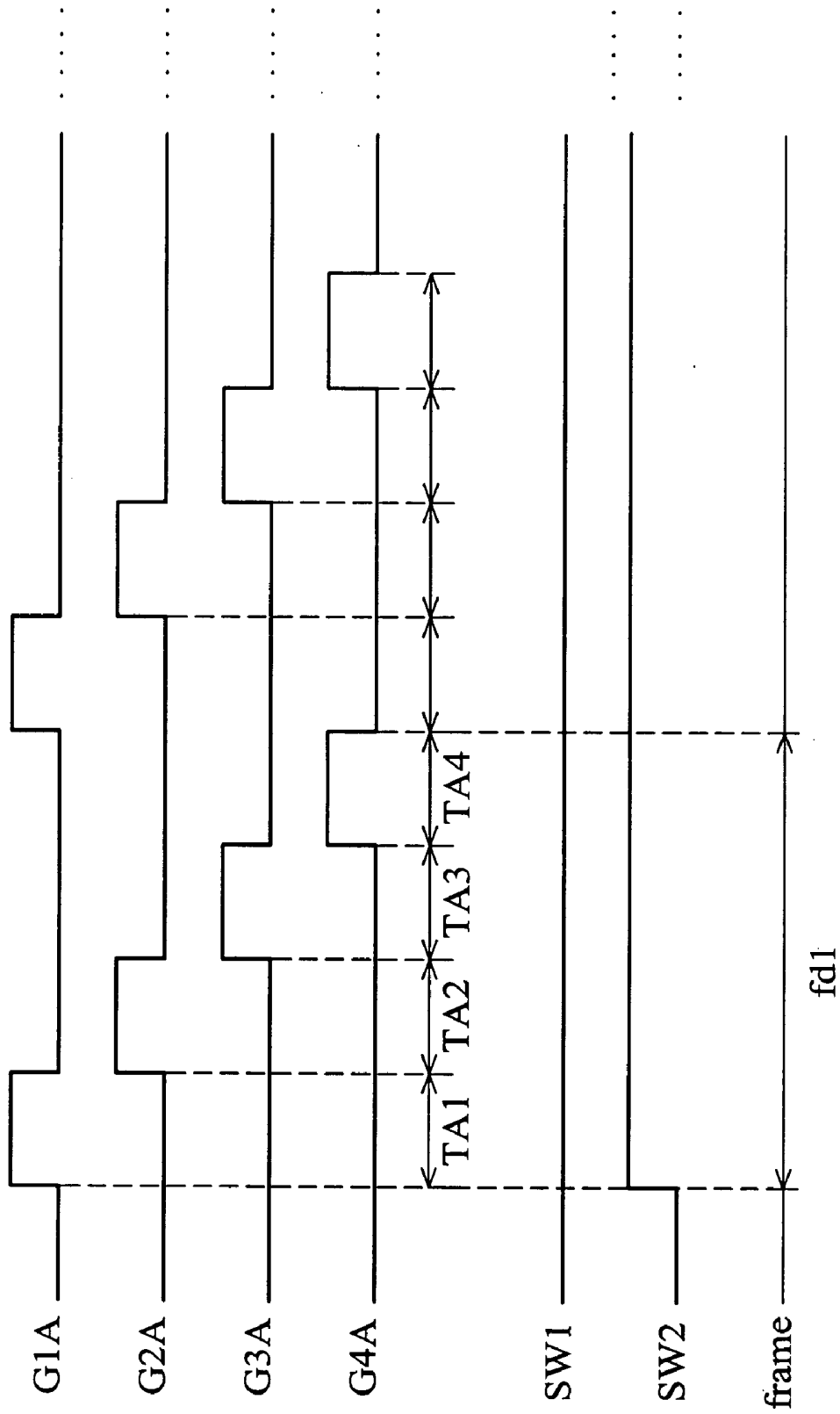

FIG. 5B

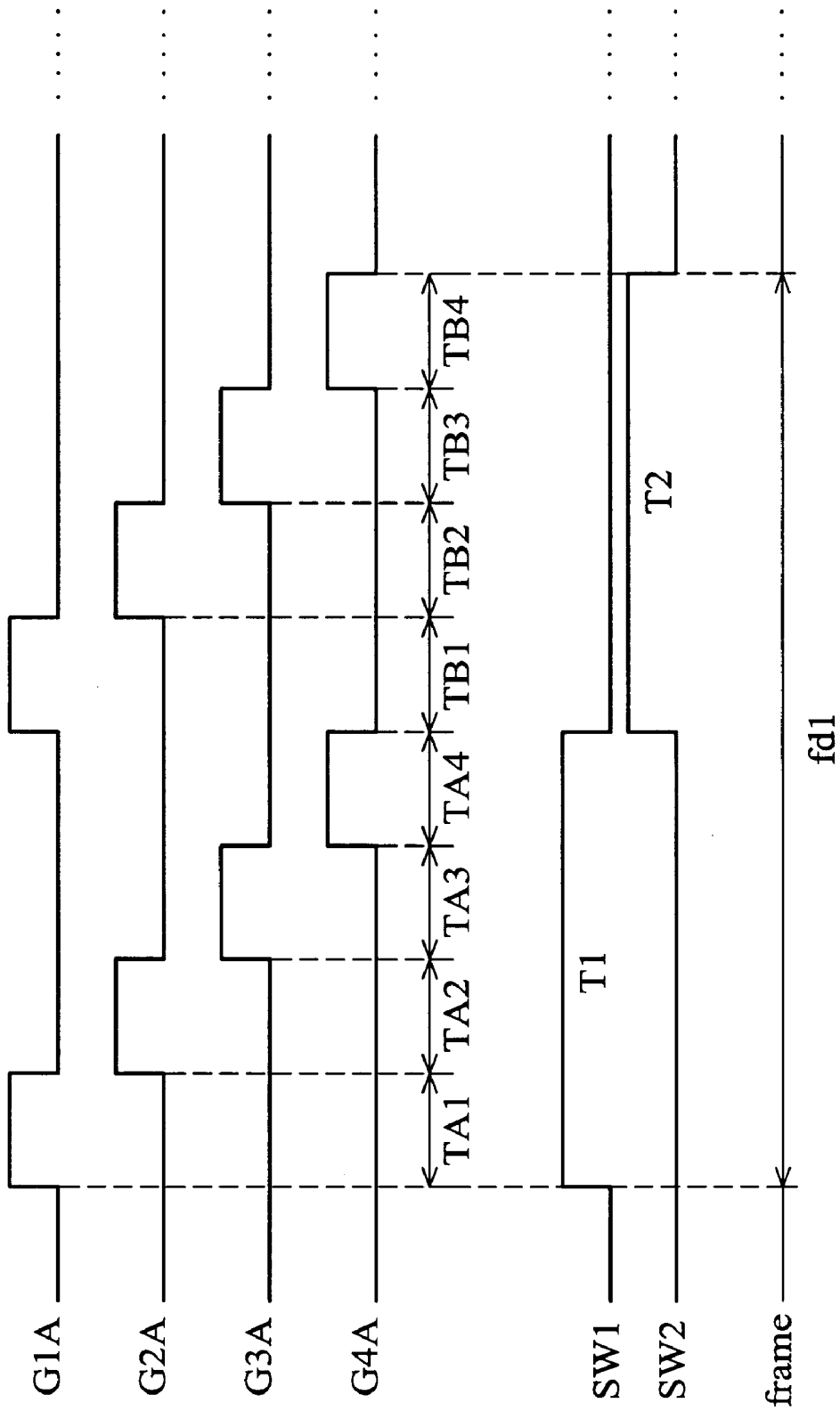

FIG. 6A

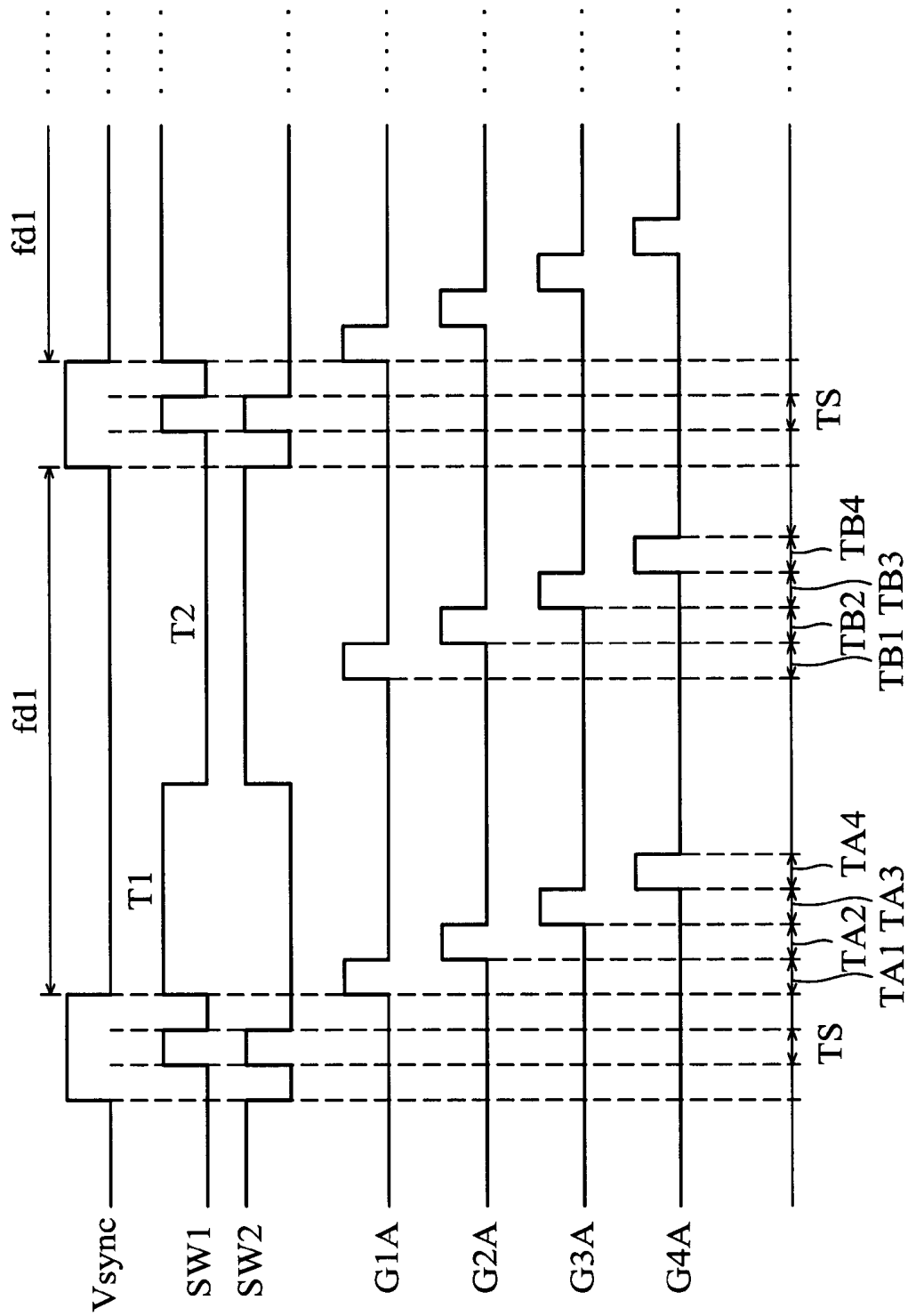

FIG. 6B

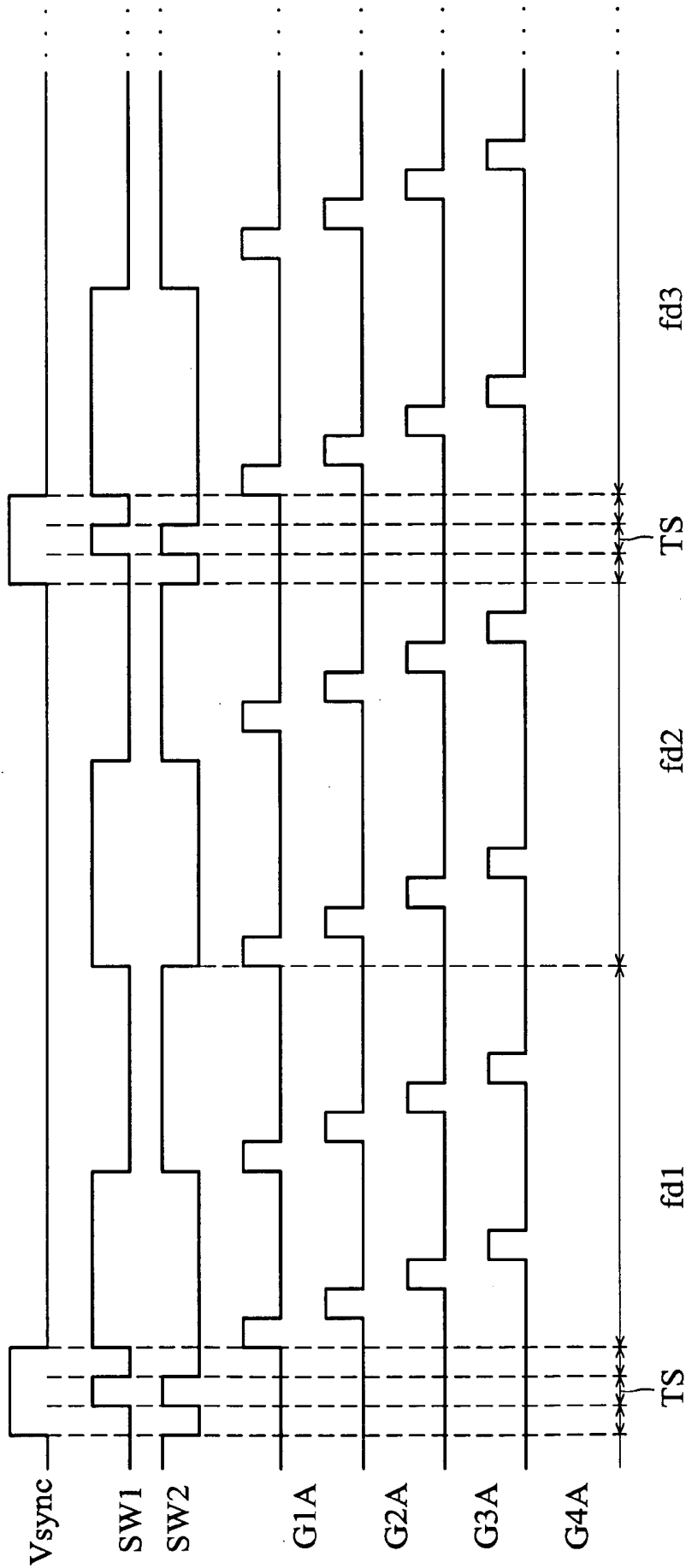

FIG. 6C

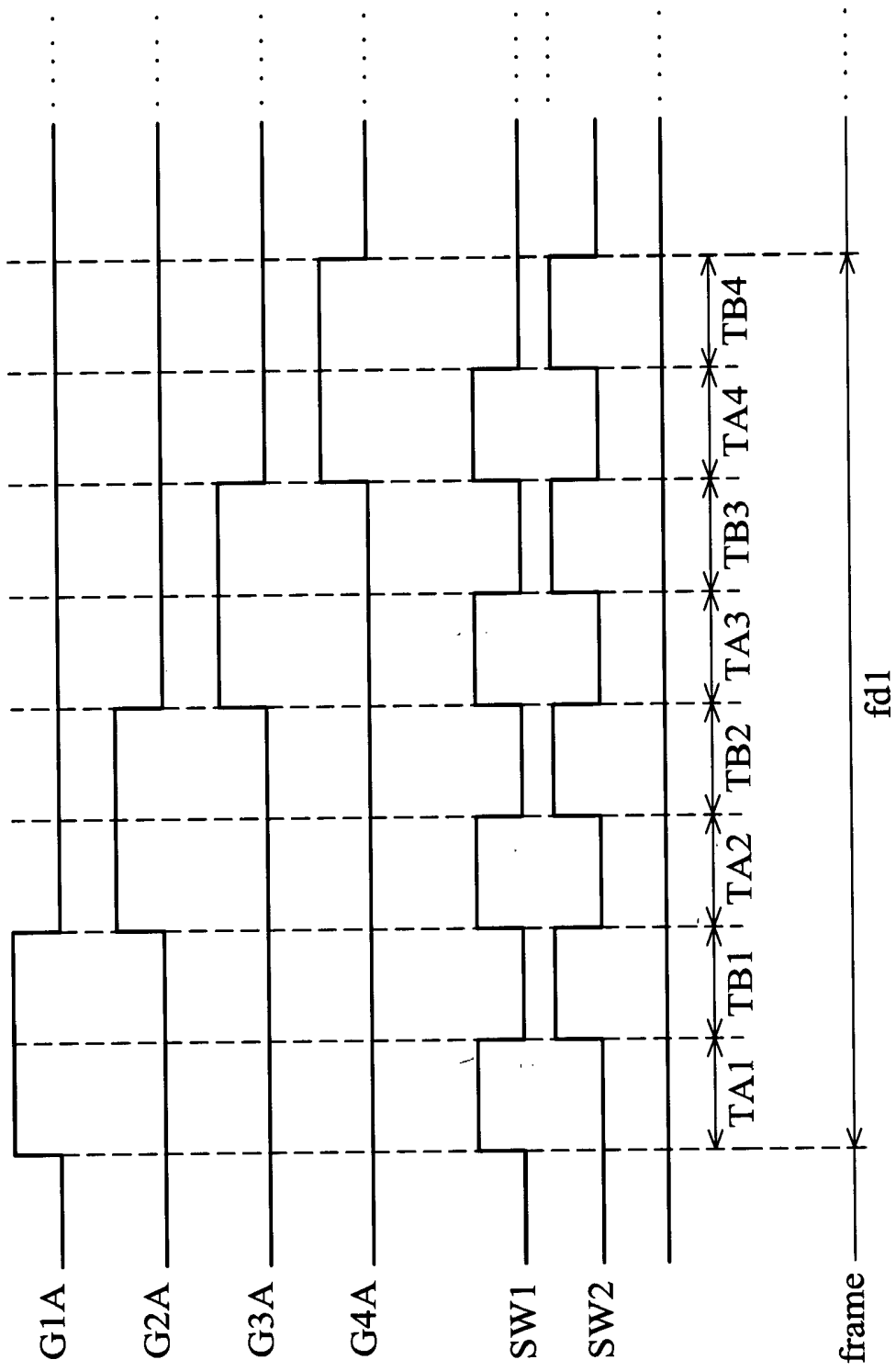

FIG. 7A

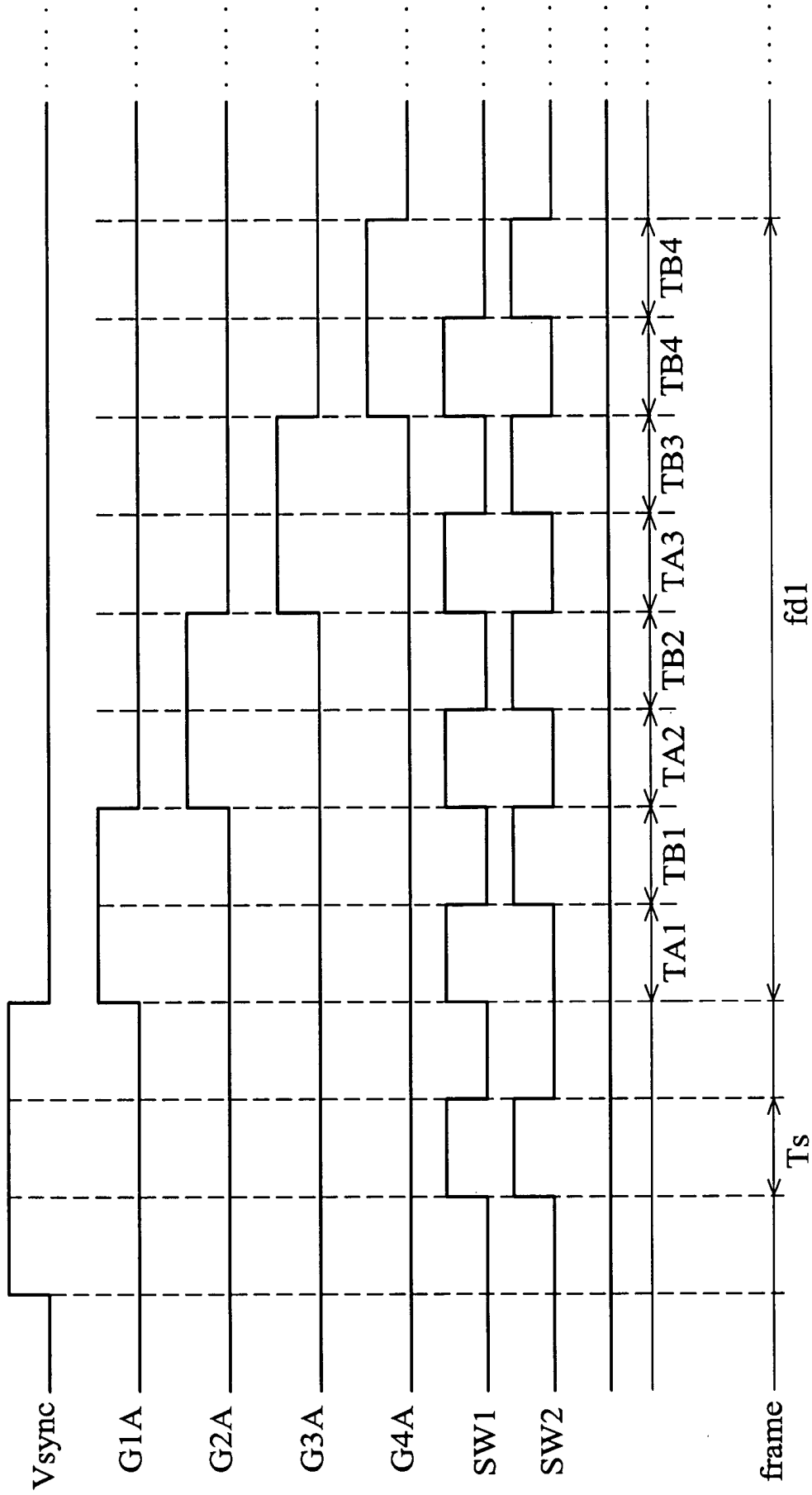

FIG. 7B

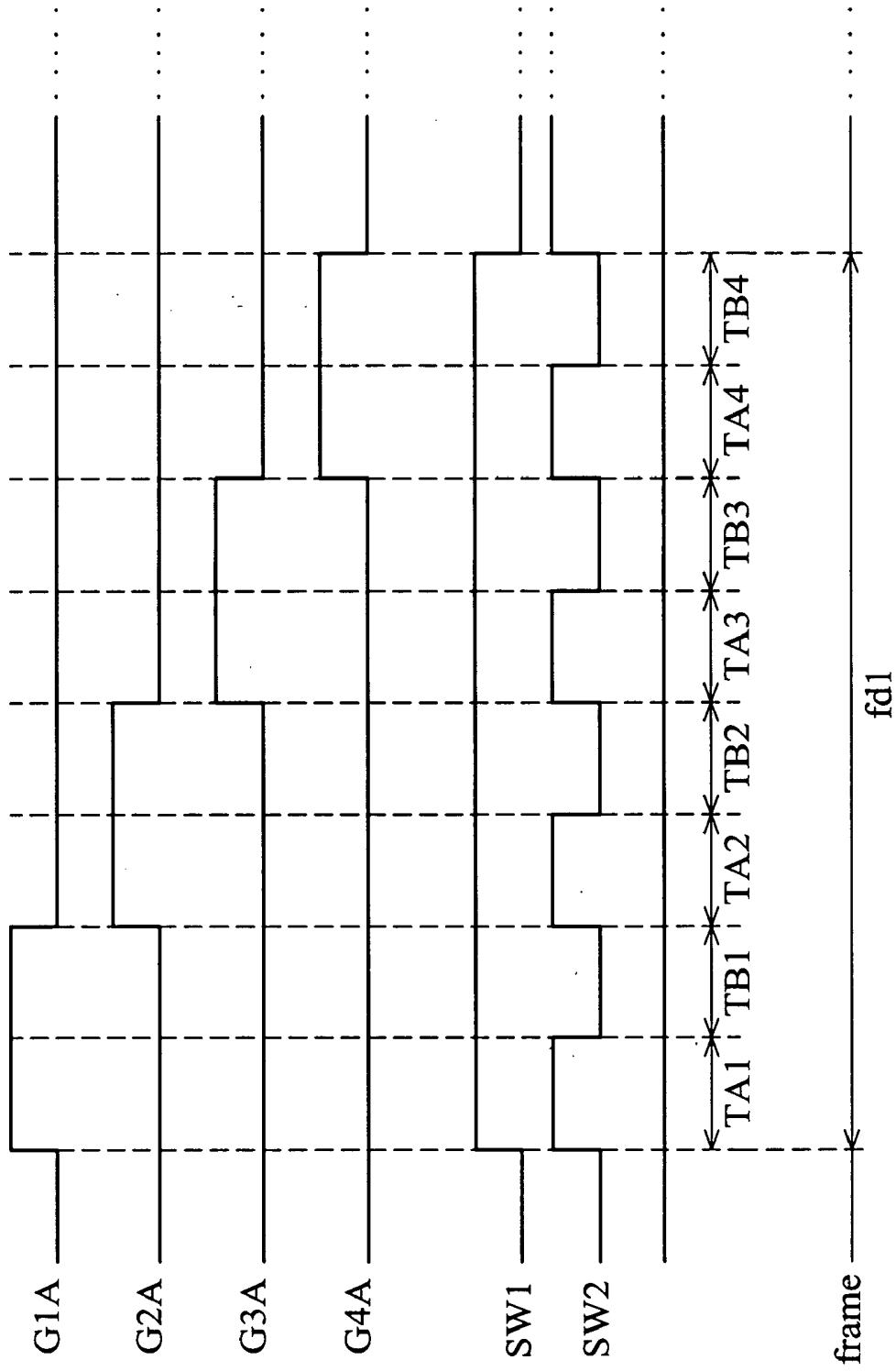

FIG. 8

METHOD FOR DRIVING TRANSFLECTIVE LIQUID CRYSTAL DISPLAY

BACKGROUND OF THE INVENTION

[0001] 1. Field of the Invention

[0002] The present invention relates to LCD driving methods, and more particularly, to a driving method for transfective liquid crystal display.

[0003] 2. Description of the Related Art

[0004] A pixel of a conventional transfective LCD has a reflective cell and a transmission cell. Unavoidably, the reflective cell having nearly double the phase difference of the transmission cell. Reduction of cell gap of the reflective cell to approach that of the transmission cell has been adopted in the past to address this issue. FIG. 1A shows a perspective diagram of a pixel of a conventional transfective LCD. The pixel includes a reflective cell 10 and a transmission cell 20. The reflective cell 10 has a reflective film 12 and a cell gap d1. The transmission cell 20 has a cell gap d2.

[0005] An equivalent circuit is shown in FIG. 1B. The reflective cell 10 and transmission cell 20 are both coupled to a storage capacitor Cs and a TFT (thin-film-transistor) transistor T1. Thus, only driving voltage can be supplied. The anti-inversion approach adjusts the cell gap d1 and d2 to the same phase difference. The cell gap d1 and d2 must be optimized to fit the LCD's operating mode, an approach that is difficult to adjust.

SUMMARY OF THE INVENTION

[0006] Accordingly, an object of the present invention is to provide a method for driving a transfective LCD effectively to achieve optimal reflectivity and transmittance without adjusting the cell gaps.

[0007] According to the object of the invention, the method for driving the transfective LCD includes the following steps. A transfective LCD is provided, having a plurality of pixels arranged in a matrix, each composed of a reflective cell and a transmission cell. The reflective cell has a first storage capacitor and a first active device, and the transmission cell having a second storage capacitor and a second active device. In the driving method of the present invention, first switching devices are coupled between the reflective cells of the pixels and first driving voltages respectively. Second switching devices are coupled between the transmission cells of the pixels and second driving voltages respectively. All the first switching devices are turned on and the first driving voltages are applied to the reflective cells in turn, and then all the second switching devices are turned on and the second driving voltages are applied to the transmission cells in turn. The first driving voltages are applied to the reflective cells in turn and the second driving voltages are applied to the transmission cells in turn in one frame period.

[0008] The present invention also provides another method for driving the transfective LCD, including the following steps. First switching devices are coupled between the reflective cells of the pixels and first driving voltages respectively. Second switching devices are coupled between the transmission cells of the pixels and second driving

voltages respectively. In the present invention, rows of the pixels are scanned in turn in one frame period. The first switching devices and the second devices are turned on at different times to apply the first driving voltage to the reflective cells and the second driving voltage to the transmission cells respectively, when each pixel row is scanned.

BRIEF DESCRIPTION OF THE DRAWINGS

[0009] The present invention can be more fully understood by reading the subsequent detailed description and examples with references made to the accompanying drawings, wherein:

[0010] FIG. 1A is a cross section illustrating the pixel structure of a conventional LCD;

[0011] FIG. 1B is an equivalent circuit illustrating the pixel structure of a conventional LCD;

[0012] FIG. 2A is a cross section illustrating the pixel structure of the present invention;

[0013] FIG. 2B is an equivalent circuit illustrating the pixel structure of the present invention;

[0014] FIG. 3A shows a reflectivity gamma curve RV1 for quarter wave phase difference in the reflectivity cell;

[0015] FIG. 3B shows a transmittance gamma curve TV1 for quarter wave phase difference in the transmission cell;

[0016] FIG. 3C shows a reflectivity gamma curve RV1 for half wave phase difference in the reflectivity cell;

[0017] FIG. 3D shows a transmittance gamma curve TV1 for half wave phase difference in the transmission cell;

[0018] FIG. 4A shows a block diagram of an LCD in the present invention;

[0019] FIG. 4B shows a schematic diagram of a pixel P22 in FIG. 4A;

[0020] FIG. 5A shows a diagram of all waveforms in the first embodiment;

[0021] FIG. 5B shows a diagram of all waveforms in the second embodiment;

[0022] FIG. 6A shows a diagram of all waveforms in the third embodiment;

[0023] FIG. 6B shows a diagram of all waveforms in the fourth embodiment;

[0024] FIG. 6C shows a diagram of all waveforms in the fifth embodiment;

[0025] FIG. 7A shows a diagram of all waveforms in the sixth embodiment;

[0026] FIG. 7B shows a diagram of all waveforms in the seventh embodiment;

[0027] FIG. 8 shows a diagram of all waveforms in the eighth embodiment.

DETAILED DESCRIPTION OF THE INVENTION

[0028] FIG. 2a shows a perspective diagram of a pixel structure in a transfective LCD of the present invention. The pixel includes a reflective cell 10 and a transmission cell 20.

The reflective cell **10** has a reflective film **12** and a cell gap **d1**. The transmission cell **20** has a cell gap **d2**. **FIG. 2B** shows an equivalent circuit of the pixel. In the reflective cell **10**, an equivalent capacitor of the reflective cell **10** is represented by **Clc1**, a storage capacitor is **Cs1**, and a TFT transistor is **T1**. In the transmission cell **20**, an equivalent capacitor of the transmission cell **20** is represented by **Clc2**, a storage capacitor is **Cs2**, and a TFT transistor is **T2**. The TFT transistors **T1** and **T2** can be disposed under the reflective film **12**.

[**0029**] Operating in quarter wave phase difference of the transmission cell **20**, a reflectivity gamma curve **RV1** showing reflectivity versus driving voltage **VR** of the reflective cell **10** is shown in **FIG. 3A**. Because the phase difference through the reflective cell **10** is twice that of the transmission cell **20**, the maximum reflectivity occurs in half wave. A transmittance gamma curve **TV1** showing transmittance versus driving voltage **VT** of the transmission cell **20** is shown in **FIG. 3B**, and the maximum transmittance occurs in quarter wave.

[**0030**] Operating in half wave phase difference of the transmission cell **20**, a reflectivity gamma curve **RV2** showing reflectivity versus driving voltage **VR** of the reflective cell **10** is shown in **FIG. 3C**. Because the phase difference through the reflective cell **10** is twice that of the transmission cell **20**, the maximum reflectivity occurs in half wave. The reflectivity decreases with driving voltage **VR** when the phase difference exceeds half wave. A transmittance gamma curve **TV2** showing transmittance versus driving voltage **VT** of the transmission cell **20** is shown in **FIG. 3D**, and the maximum transmittance occurs in half wave.

[**0031**] Because the pixel in the present invention has two TFT, **T1** and **T2**, and two storage capacitors **Cs1** and **Cs2**, to control driving voltage **VR** and **VT** respectively, the reflective cell **10** and transmission cell **20** achieve the same phase difference without adjusting the cell gap **d1** and **d2**. The driving voltage **VR** for the reflective cell **10** can be driven by the quarter wave gamma curve **RV1** or by half wave gamma curve **RV2**. The driving voltage **VT** for the transmission cell **20** can be driven by the quarter wave gamma curve **TV1** or by half wave gamma curve **TV2**. The reflective cell **10** and the transmission cell **20** are corrected by reflectivity and transmittance gamma curve respectively to meet requirements.

[**0032**] **FIG. 4A** shows a block diagram of an LCD in the present invention. The LCD includes a TFT transistor array **300**, an image-signal driving circuit **100** and **120**, and a scan-signal driving circuit **200**. **FIG. 4B** shows a schematic diagram of a pixel **P22** in **FIG. 4A**. Other pixels in **FIG. 4A** have the same schematic as shown in **FIG. 4A**. The pixel **P22** has a reflective cell **10** and a transmission cell **20**, and thus requires two sets of TFT transistors and storage capacitors.

[**0033**] The TFT transistor **T1** is disposed at the intersection of the row **G2A** and column **D2A**. A gate of the TFT transistor **T1** is coupled to row **2A**, a drain of the TFT **T1** is coupled to column **D2A**, and a source of the TFT transistor **T1** is coupled to **Clc1** and storage capacitor **Cs1**. The TFT transistor **T2** is disposed at the intersection of row **G2A** and column **D2B**. A gate of the TFT transistor **T2** is coupled to row **2A**, a drain of the TFT **T2** is coupled to column **D2B**, and a source of the TFT transistor **T2** is coupled to **Clc2** and

storage capacitor **Cs2**. All pixels in the TFT transistor array **300** have the same wiring structure.

[**0034**] The scan signal driving circuit **200** generates scan signals fed to gates of TFT transistors **T1** or **T2** via rows **G1A-G4A**. The image signal driving circuit **100** generates image signals corresponding to scan signals fed to reflective cells **10** via column **D1A-D4A**, switching devices **SD1** and TFT transistor array **300**. Also, the image signal driving circuit **100** generates image signals corresponding to scan signals fed to transmissions cell **20** via column **D1B-D4B**, switching devices **SD2** and TFT transistor array **300**.

[**0035**] The First Embodiment

[**0036**] **FIG. 5A** shows a diagram of all waveforms in the first embodiment. In this embodiment, only reflective cells **10** are scanned in turn in one frame period **fd1** as shown in **FIG. 5A**. In **FIG. 5A**, a frame period **fd1** is divided into periods **TA1**, **TA2**, **TA3** and **TA4**. The image signal driving circuit **100** feeds image signals (first driving voltages) to capacitors **Clc1** and **Cs1** in reflective cell **10** via columns **D1A-D4A** and switching device **SD1** in periods **TA1**, **TA2**, **TA3** and **TA4**, when rows **G1A-G4A** are active respectively. In frame period **fd1**, all switching devices **SD1** are turned on and all switching devices **SD2** are turned off.

[**0037**] The Second Embodiment

[**0038**] **FIG. 5B** shows a diagram of all waveforms in the second embodiment. In this embodiment, only transmission cells **20** are scanned in turn in one frame period **fd1** as shown in **FIG. 5B**. In **FIG. 5B**, a frame period **fd1** is divided into periods **TA1**, **TA2**, **TA3** and **TA4**. The image signal driving circuit **100** feeds image signals (second driving voltages) to capacitors **Clc2** and **Cs2** in reflective cell **20** via columns **D1B-D4B** and switching device **SD2** in periods **TA1**, **TA2**, **TA3** and **TA4**, when rows **G1A-G4A** are active respectively. In frame period **fd1**, all switching devices **SD2** are turned on and all switching devices **SD1** are turned off.

[**0039**] In the first and second embodiments, only a reflective cell or transmission cell is turned on for display in one frame period, thereby saving power.

[**0040**] The Third Embodiment

[**0041**] **FIG. 6A** shows a diagram of all waveforms in the third embodiment. In one frame period **fd1**, the reflective cells **10** are turned on in turn when the first switching devices **SD1** are turned on, and the transmission cells **20** are then turned on in turn when the second switching devices **SD2** are turned on, as shown in **FIG. 6A**. In **FIG. 6A**, period **T1** is divided into periods **TA1-TA4**, and period **T2** is divided into periods **TB1-TB2**, and frame period **fd1** includes periods **T1** and **T2**.

[**0042**] The image signal driving circuit **100** feeds image signals (first driving voltages) to capacitors **Clc1** and **Cs1** in reflective cells **10** via columns **D1A-D4A** and switching devices **SD1** in periods **TA1**, **TA2**, **TA3** and **TA4**, when rows **G1A-G4A** are active respectively. The image signal driving circuit **100** then feeds image signals (second driving voltages) to capacitors **Clc2** and **Cs2** in transmission cells **20** via columns **D1B-D4B** and switching devices **SD2** in periods **TB1**, **TB2**, **TB3** and **TB4**, when rows **G1A-G4A** are active respectively. In frame period **fd1**, all switching devices **SD1** are turned on and all switching devices **SD2** are turned off. In periods **TA1-TA4** (**T1**), all switching devices **SD1** are

turned on and all switching devices SD2 are turned off. In periods TB1-TB4 (T2), all switching devices SD2 are turned on and all switching devices SD1 are turned off.

[0043] The Fourth Embodiment

[0044] FIG. 6B shows a diagram of all waveforms in the third embodiment. As shown in FIG. 6A, in one frame period fd1, the reflective cells 10 are turned on in turn when the first switching devices SD1 are turned on, and the transmission cells 20 are then turned on in turn when the second switching devices SD2 are turned on. In this case, a charge sharing period TS occurs before each frame period fd1, wherein the period TS depends on an external signal Vsync. In each charge sharing period TS, all switching devices SD1 and SD2 are turned on without scanning rows G1A-G4A.

[0045] The image signal driving circuit 100 feeds image signals (first driving voltages) to capacitors Clc1 and Cs1 in reflective cell 10 via columns D1A-D4A and switching device SD1 in periods TA1, TA2, TA3 and TA4, when rows G1A-G4A are active respectively. The image signal driving circuit 100 then feeds image signals (second driving voltages) to capacitors Clc2 and Cs2 in transmission cell 20 via columns D1B-D4B and switching device SD2 in periods TB1, TB2, TB3 and TB4, when rows G1A-G4A are active respectively. In periods TA1-TA4 (T1), all switching devices SD1 are turned on and all switching devices SD2 are turned off. In periods TB1-TB4 (T2), all switching devices SD2 are turned on and all switching devices SD1 are turned off.

[0046] In the period TS before the period fd1, all the switching devices SD1 and SD2 are turned on without scanning rows G1A-G4A. Thus, charge sharing may occur between capacitors Cs1 and Cs2 of the reflective cells 10 and transmission cells 20 to share charges therebetween.

[0047] The Fifth Embodiment

[0048] FIG. 6C shows a diagram of all waveforms in the fifth embodiment. The driving method of the embodiment is similarly to that in the fifth embodiment. In this case, a charge sharing period TS is added alternately before frame periods, wherein the period TS depends on an external signal Vsync. In each charge sharing period TS, all switching devices SD1 and SD2 are turned on without scanning rows G1A-G4A to share capacitors Cs1 and Cs2 of the reflective cells 10 and transmission cells 20. In FIG. 6, the charge sharing periods TS are added before the frame periods fd1 and fd3.

[0049] The Sixth Embodiment

[0050] FIG. 7A shows a diagram of all waveforms in the sixth embodiment. As shown in FIG. 7A, in frame period fd1, all switching devices SD1 are turned on in periods TA1, TA2, TA3 and TA4, and all switching devices SD2 are turned on in periods TB1, TB2, TB3 and TB4. Rows are activated in sequence periods G1A-G2A-G3A-G4A. Row G1A is activated in periods TA1 and TB1 corresponding to switching device becoming active alternatively. Row G2A is activated in periods TA2 and TB2 corresponding to switching device becoming active alternatively. Row G3A is activated in periods TA3 and TB3 corresponding to switching device becoming active alternatively. Row G4A is activated in periods TA4 and TB4 corresponding to switching device becoming active alternatively.

[0051] In periods TA1, TA2, TA3 and TA4, the image signal driving circuit 100 feeds image signals (first driving voltages) to capacitors Clc1 and Cs1 of the reflective cells 10 via columns D1A-D4A when rows G1A-G4A are scanned respectively. In periods TB1, TB2, TB3 and TB4, the image signal driving circuit 100 feeds image signals (second driving voltages) to capacitors Clc2 and Cs2 of the transmission cells 20 via columns D2A-D2A when rows G1A-G4A are scanned respectively. That is to say, rows of the pixels are scanned in turn in one frame period, and the reflective cells and the transmission cells are turned on alternately when each pixel row is scanned.

[0052] The Seventh Embodiment

[0053] FIG. 7B shows a diagram of all waveforms in the seventh embodiment. As shown in FIG. 7B, in one frame period fd1, rows of the pixels are scanned in turn in one frame period, and the reflective cells and the transmission cells are turned on alternately when each pixel row is scanned. Furthermore, a charge sharing period TS occurs before frame period fd1 to share charges between the transmission cells and the reflective cells, wherein the period TS depends on an external signal Vsync. In charge sharing period TS, all switching devices SD1 and SD2 are turned on without scanning rows G1A-G4A.

[0054] The Eighth Embodiment

[0055] FIG. 8 shows a diagram of all waveforms in the eighth embodiment. As shown in FIG. 7A, in frame period fd1, all switching devices SD1 are turned on in whole period fd1 and all switching devices SD2 are turned on in periods TA1, TA2, TA3 and TA4. Rows are activated in sequence periods G1A-G2A-G3A-G4A.

[0056] In periods TA1, TA2, TA3 and TA4, the image signal driving circuit 100 feeds image signals (first driving voltages) to capacitors Clc1 and Cs1 of the reflective cells 10 via columns D1A-D4A and also feeds image signals (second driving voltages) to capacitors Clc2 and Cs2 of the transmission cells 20 via columns D2A-D2A when rows G1A-G4A are scanned respectively. In periods TB1, TB2, TB3 and TB4, the image signal driving circuit 100 only feeds image signals (first driving voltages) to capacitors Clc1 and Cs1 of the transmission cells 20 via columns D1A-D1A when rows G1A-G4A are scanned respectively.

[0057] Thus, the present invention can drive the transmissive LCD effectively to achieve optimal reflectivity and transmittance without adjusting the cell gaps of the same phase difference according to the pixel structure and driving methods.

[0058] Although the present invention has been described in its preferred embodiments, it is not intended to limit the invention to the precise embodiments disclosed herein. Those who are skilled in this technology can still make various alterations and modifications without departing from the scope and spirit of this invention. Therefore, the scope of the present invention shall be defined and protected by the following claims and their equivalents.

What is claimed is:

1. A method for driving a transmissive LCD, wherein the transmissive LCD has a plurality of pixels arranged in a matrix, each including a reflective cell and a transmission cell, the reflective cell having a first storage capacitor and a

first active device, and the transmission cell having a second storage capacitor and a second active device, the method comprising the steps of:

providing first switching devices coupled between the reflective cells of the pixels and first driving voltages respectively;

providing second switching devices coupled between the transmission cells of the pixels and second driving voltages respectively;

turning on all the first switching devices and scanning the reflective cells in turn to apply the first driving voltages to the reflective cells in turn; and

turning on all the second switching devices and scanning the transmission cells in turn to apply the second driving voltages to the transmission cells in turn;

wherein the first driving voltages are applied to the reflective cells in turn and the second driving voltages are applied to the transmission cells in turn in one frame period.

2. The method as claimed in claim 1, wherein the first switching devices are turned on when the second switching devices are turned off, and the first switching devices are turned off when the second switching device is turned on.

3. The method as claimed in claim 1, further comprising a step of turning on all the first switching devices and second switching devices without scanning any pixel before the frame period.

4. A method for driving a transfective LCD, wherein the transfective LCD has a plurality of pixels arranged in a matrix, each pixel including a reflective cell and a transmission cell, the reflective cell having a first storage capacitor and a first active device and the transmission cell having a second storage capacitor and a second active device, the method comprising the steps of:

providing first switching devices coupled between the reflective cells of the pixels and first driving voltages respectively;

providing second switching devices coupled between the transmission cells of the pixels and second driving voltages respectively;

scanning each row of the pixels in turn in one frame period; and

turning on the first switching device and the second device at different times to apply the first driving voltage to the reflective cells and the second driving voltage to the transmission cells respectively, when each pixel row is scanned.

5. The method as claimed in claim 4, wherein reflective cells are turned on when the first switching devices and the second switching devices are turned on and off respectively.

6. The method as claimed in claim 4, wherein when transmission cells are turned on when the first switching devices and the second switching devices are turned off and on respectively.

7. The method as claimed in claim 6, further comprising a step of turning on all the first switching devices and second switching devices without scanning any pixel before the frame period.

8. A method for driving a transfective LCD, wherein the transfective LCD has a plurality of pixels arranged in a matrix, each pixel including a reflective cell and a transmission cell, the reflective cell having a first storage capacitor and a first active device and the transmission cell having a second storage capacitor and a second active device, the method comprising the steps of:

providing first switching devices coupled between the reflective cells of the pixels and first driving voltages respectively;

providing second switching devices coupled between the transmission cells of the pixels and second driving voltages respectively;

scanning each row of the pixels in turn in one frame period; and

turning on the first switching device and the second switching devices simultaneously to apply the first driving voltages to the reflective cells and the second driving voltage to the transmission cells simultaneously when each pixel row is scanned, wherein the second switching devices are turned off earlier than the first switching devices.

9. A method for driving a transfective LCD, wherein the transfective LCD has a plurality of pixels arranged in a matrix, each pixel including a reflective cell and a transmission cell, the reflective cell having a first storage capacitor and a first active device and the transmission cell having a second storage capacitor and a second active device, the method comprising the steps of:

providing first switching devices coupled between the reflective cells of the pixels and first driving voltages respectively;

providing second switching devices coupled between the transmission cells of the pixels and second driving voltages respectively; and

turning on the first switching devices to apply the first driving voltages to the reflective cells of the pixels and scanning each row of the pixels in turn simultaneously in one frame period.

10. A method for driving a transfective LCD, wherein the transfective LCD has a plurality of pixels arranged in a matrix, each pixel including a reflective cell and a transmission cell, the reflective cell having a first storage capacitor and a first active device and the transmission cell having a second storage capacitor and a second active device, the method comprising the steps of:

providing first switching devices coupled between the reflective cells of the pixels and first driving voltages respectively;

providing second switching devices coupled between the transmission cells of the pixels and second driving voltages respectively; and

turning on the second switching devices to apply the second driving voltages to the transmission cells of the pixels and scanning each row of the pixels in turn simultaneously in one frame period.

专利名称(译)	透射反射型液晶显示器的驱动方法		
公开(公告)号	US20040201560A1	公开(公告)日	2004-10-14
申请号	US10/643186	申请日	2003-08-18
[标]申请(专利权)人(译)	财团法人工业技术研究院		
申请(专利权)人(译)	工业技术研究院		
当前申请(专利权)人(译)	群创光电		
[标]发明人	SHEN YUH REN CHEN CHING YIH		
发明人	SHEN, YUH-REN CHEN, CHING-YIH		
IPC分类号	G02F1/133 G09G3/20 G09G3/36		
CPC分类号	G09G2300/0456 G09G3/3659		
优先权	092108095 2003-04-09 TW		
其他公开文献	US7009592		
外部链接	Espacenet USPTO		

摘要(译)

一种用于驱动透反射LCD的方法。在本发明中，透射反射型LCD具有以矩阵排列的多个像素，并且每个像素包括反射单元和透射单元。反射单元和传输单元由不同的晶体管驱动。在本发明的方法中，所有第一开关器件导通，然后第一驱动电压依次施加到反射单元。之后，接通所有第二开关装置，然后依次将第二驱动电压施加到传输单元。依次将第一驱动电压施加到反射单元，并且在一个帧周期中依次将第二驱动电压施加到透射单元。

