



(19) **United States**

(12) **Patent Application Publication** (10) **Pub. No.: US 2004/0062027 A1**

Kim et al.

(43) **Pub. Date:**

Apr. 1, 2004

(54) **BACKLIGHT ASSEMBLY AND LIQUID CRYSTAL DISPLAY DEVICE USING THE SAME**

(52) **U.S. Cl.** **362/31; 362/26**

(76) **Inventors:** **Kyu-Seok Kim, Yongin-si (KR); Ik-Soo Lee, Suwon-si (KR); Jeong-Seok Oh, Seoul (KR)**

(57) **ABSTRACT**

Correspondence Address:
GRAY CARY WARE & FREIDENRICH LLP
2000 UNIVERSITY AVENUE
E. PALO ALTO, CA 94303-2248 (US)

A backlight assembly includes a first light guide having a first light incident face, a first light reflective face connected to the first light incident face and having a stepped portion, and a first light exiting face facing the first light reflective face. The backlight assembly further includes a second light guide having a second light incident face corresponding to the first light incident face, a second light reflective face connected to the second light incident face and facing the first light reflective face, and second light exiting face facing the second light reflective face. A light reflective plate is inserted into a gap between the first and second light guides. The first and second display panels, respectively, are installed on the first light guide and the second light guide. The generated light is used more efficiently and the overall thickness of an LCD device is decreased.

(21) **Appl. No.:** **10/452,319**

(22) **Filed:** **May 30, 2003**

(30) **Foreign Application Priority Data**

Sep. 26, 2002 (KR) 2002-58319

Publication Classification

(51) **Int. Cl.⁷** **G01D 11/28**

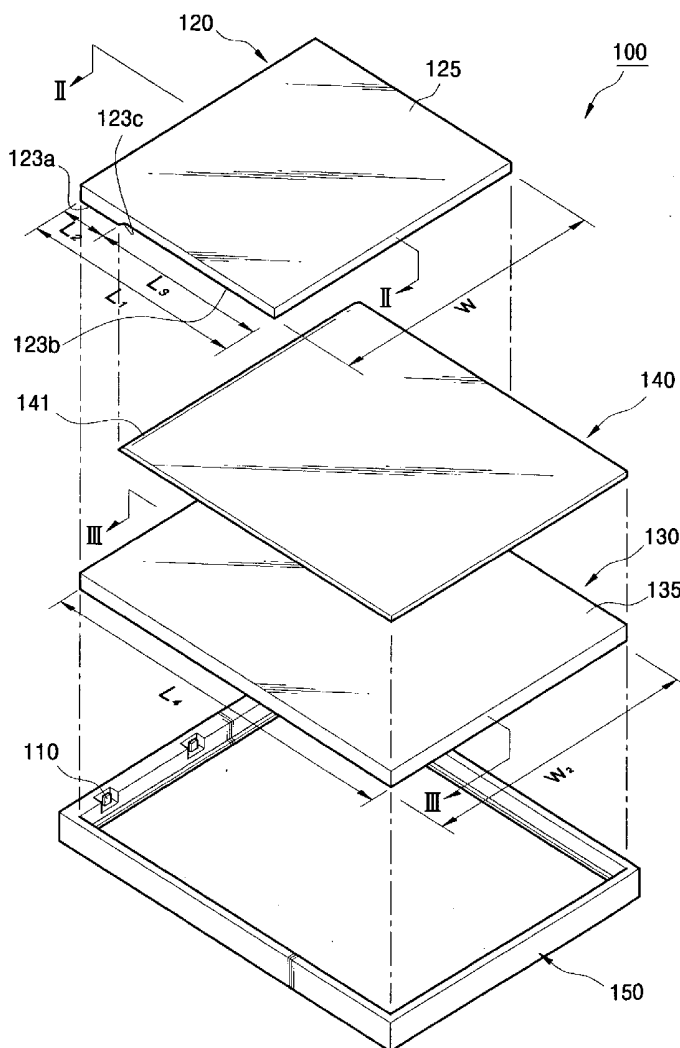

FIG. 1

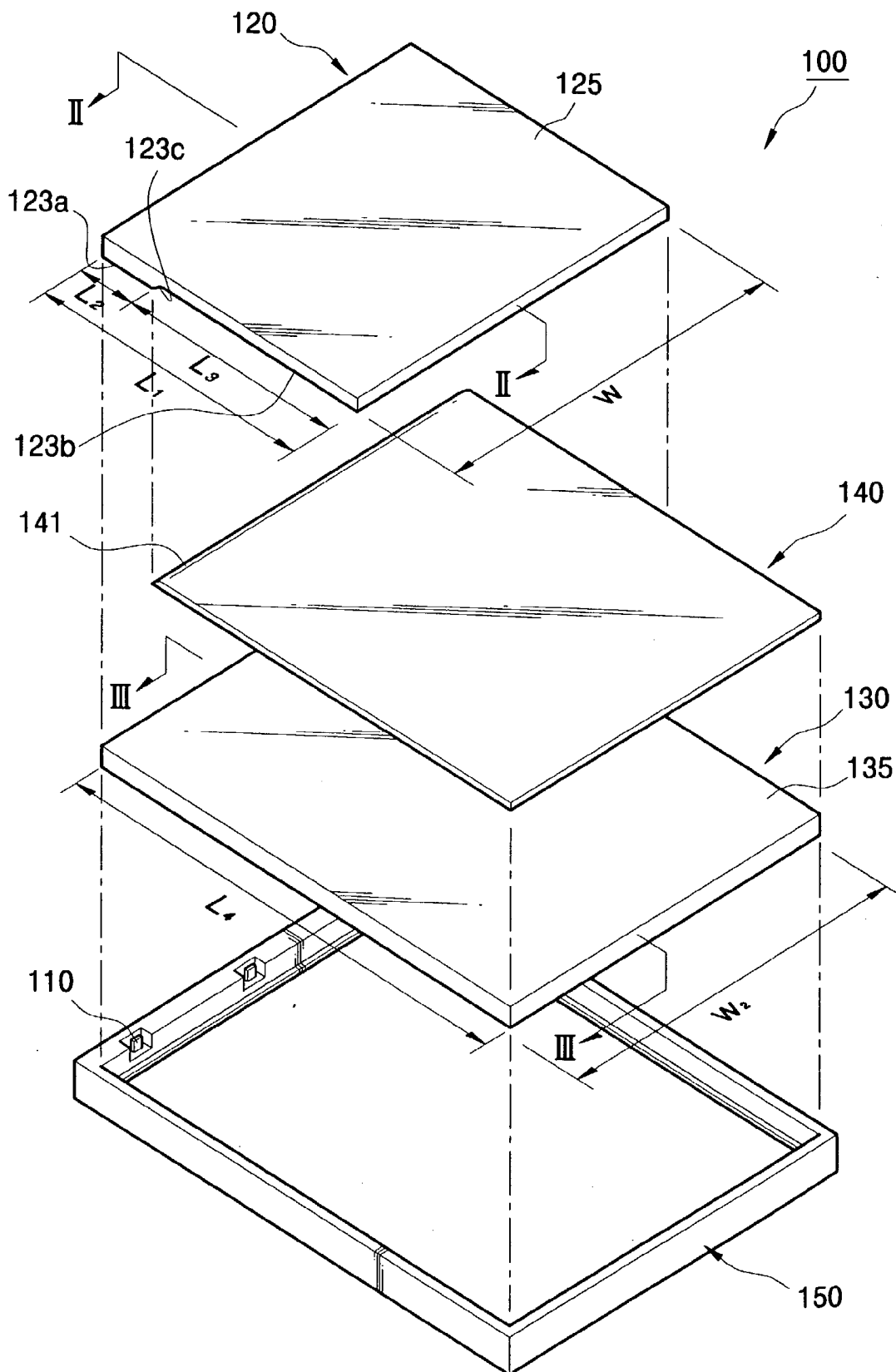

FIG. 2

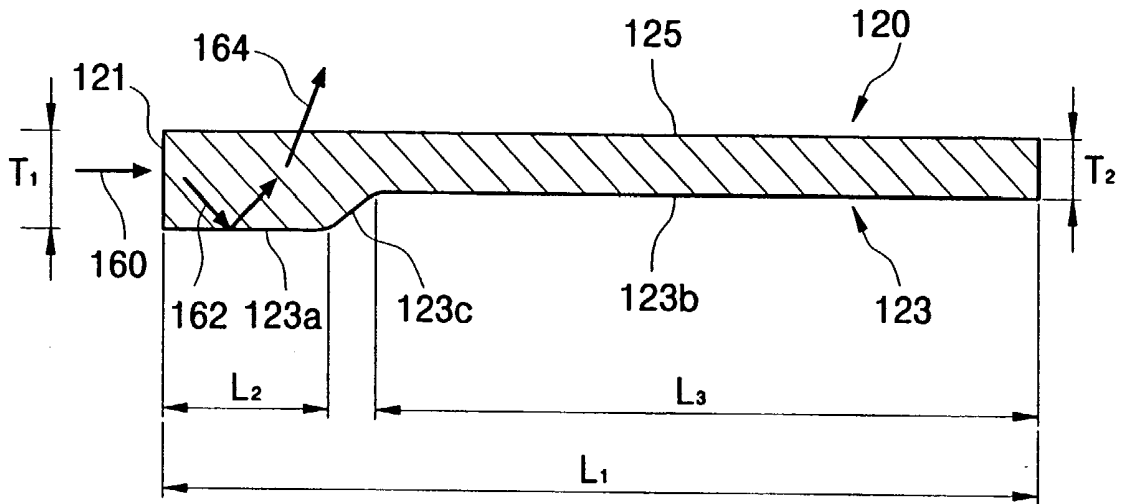

FIG. 3

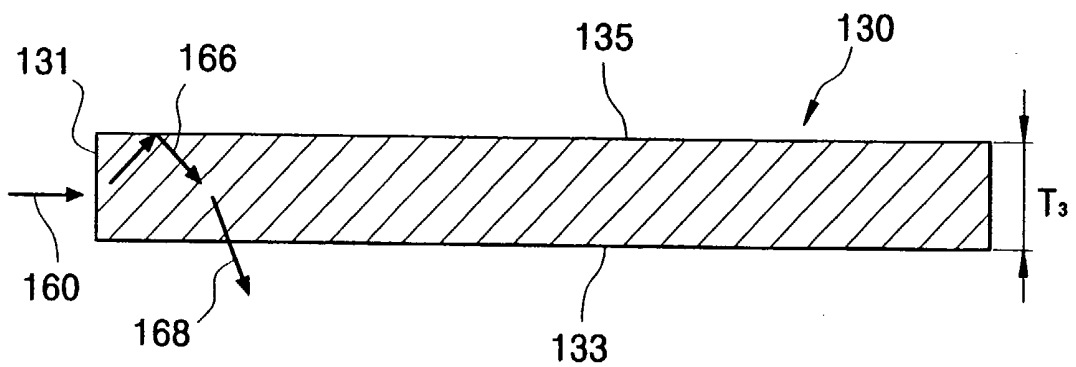

FIG.4

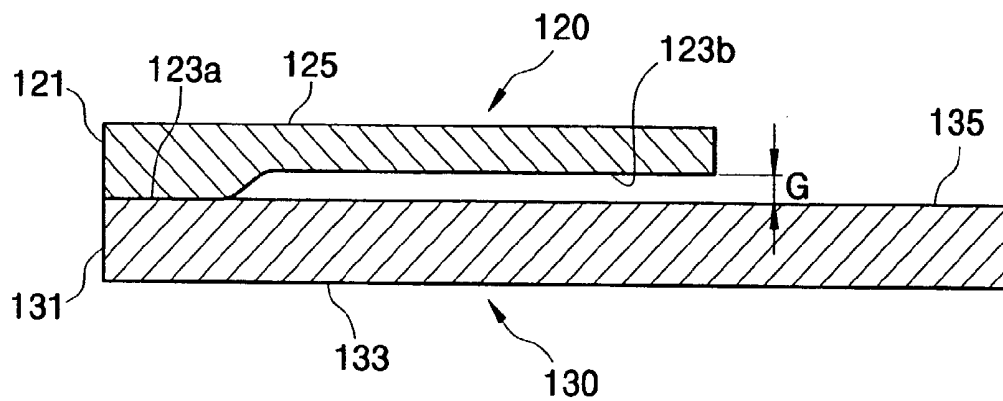

FIG.5

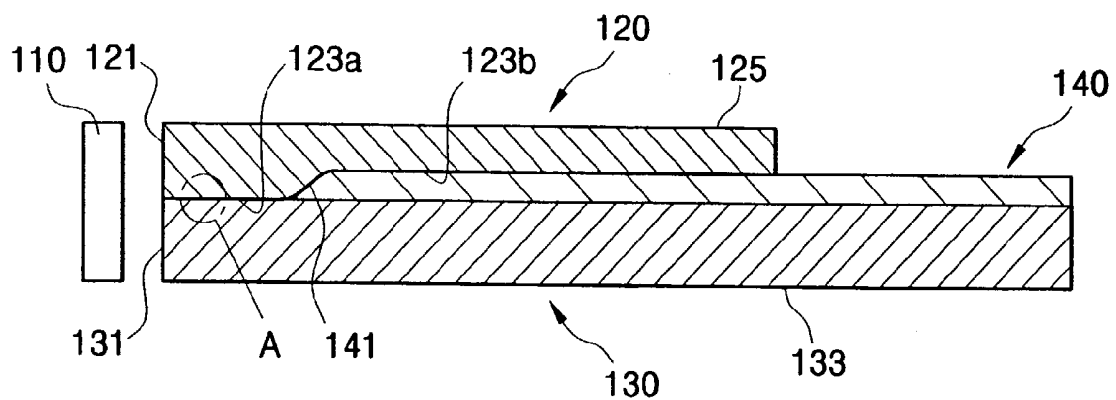

FIG. 6

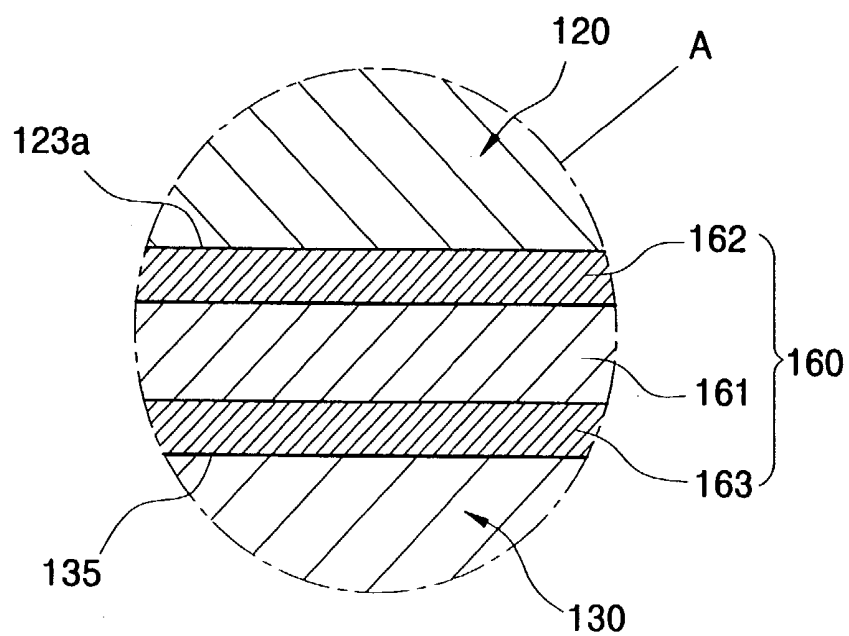

FIG. 7

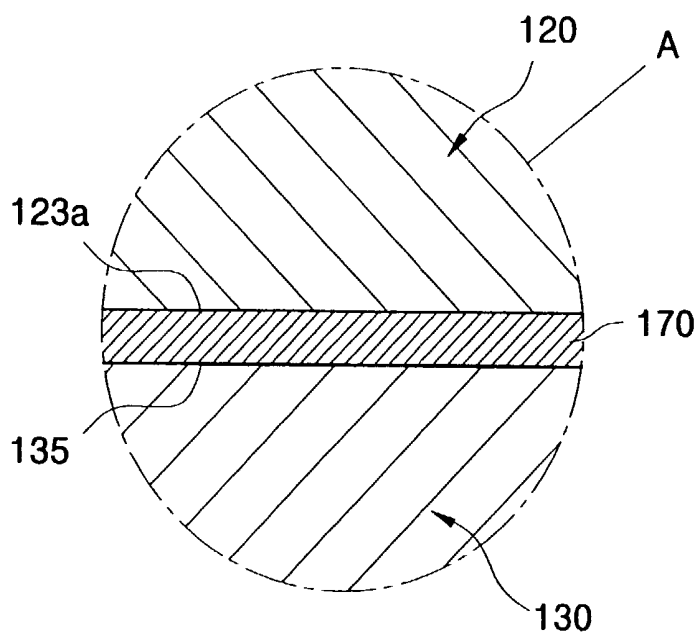

FIG.8

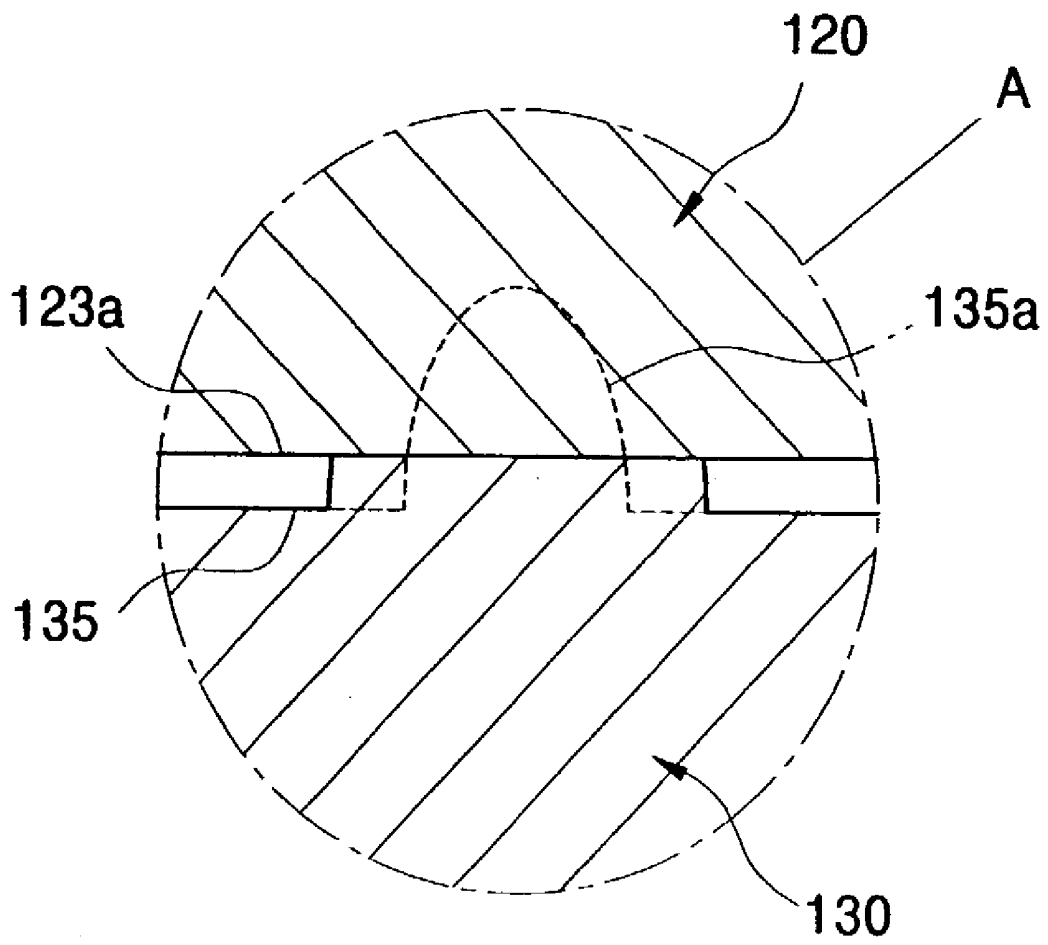

FIG.9

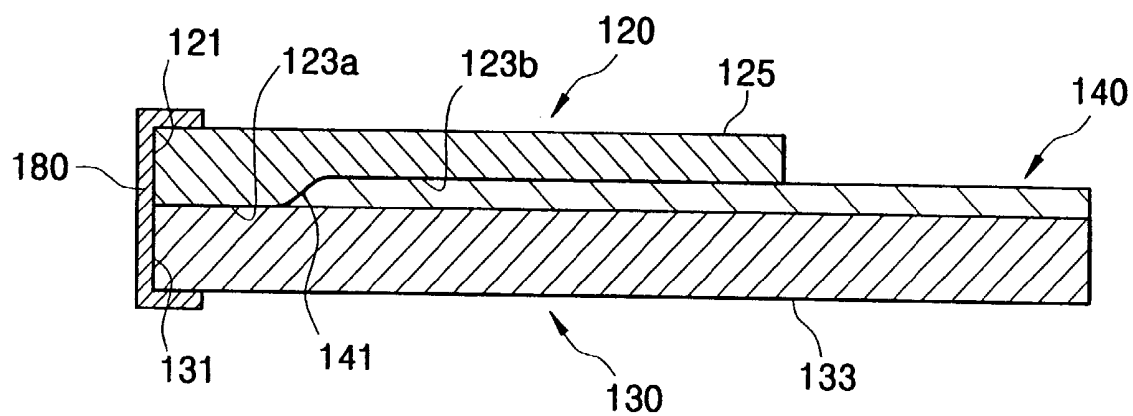

FIG. 10

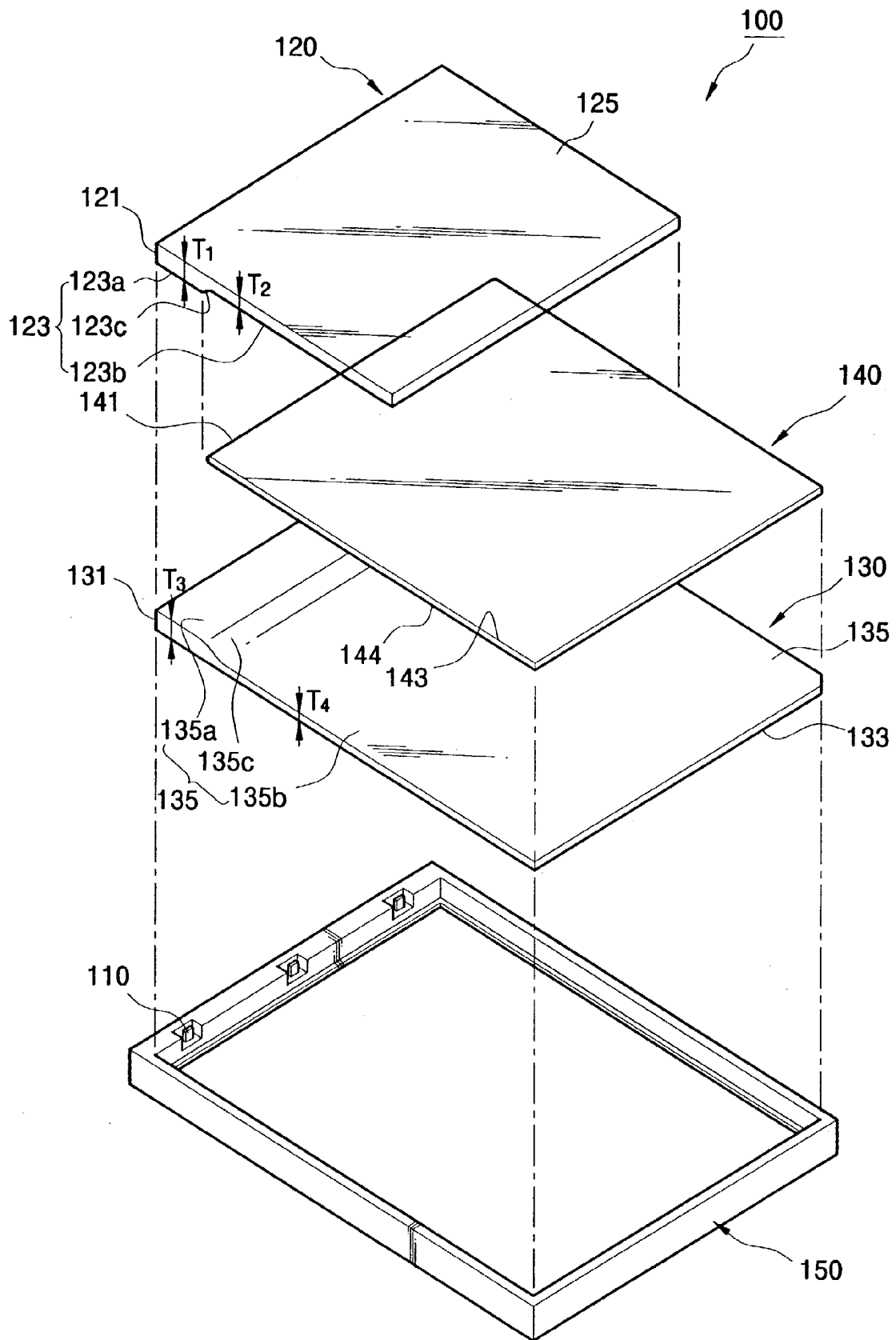

FIG. 11

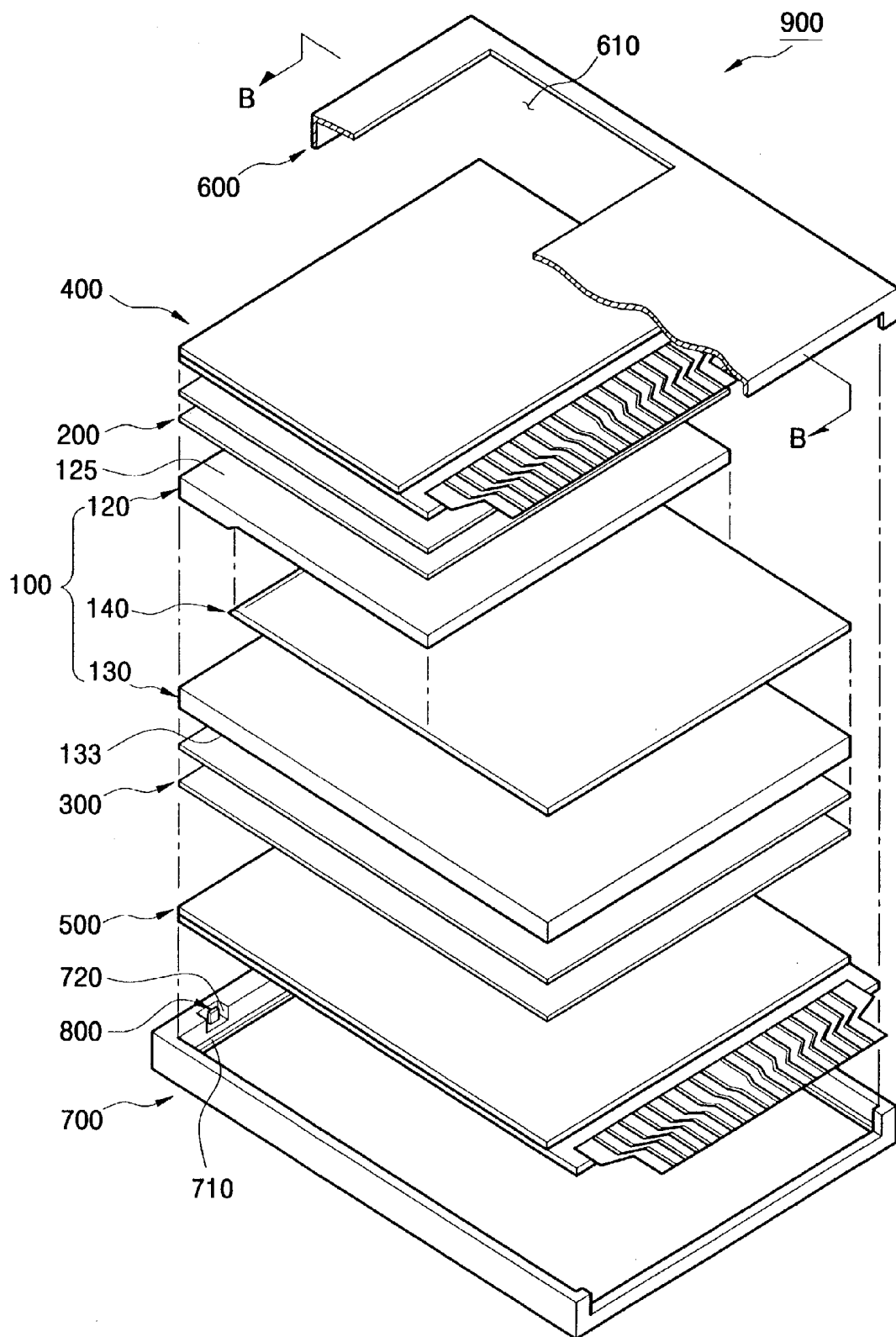
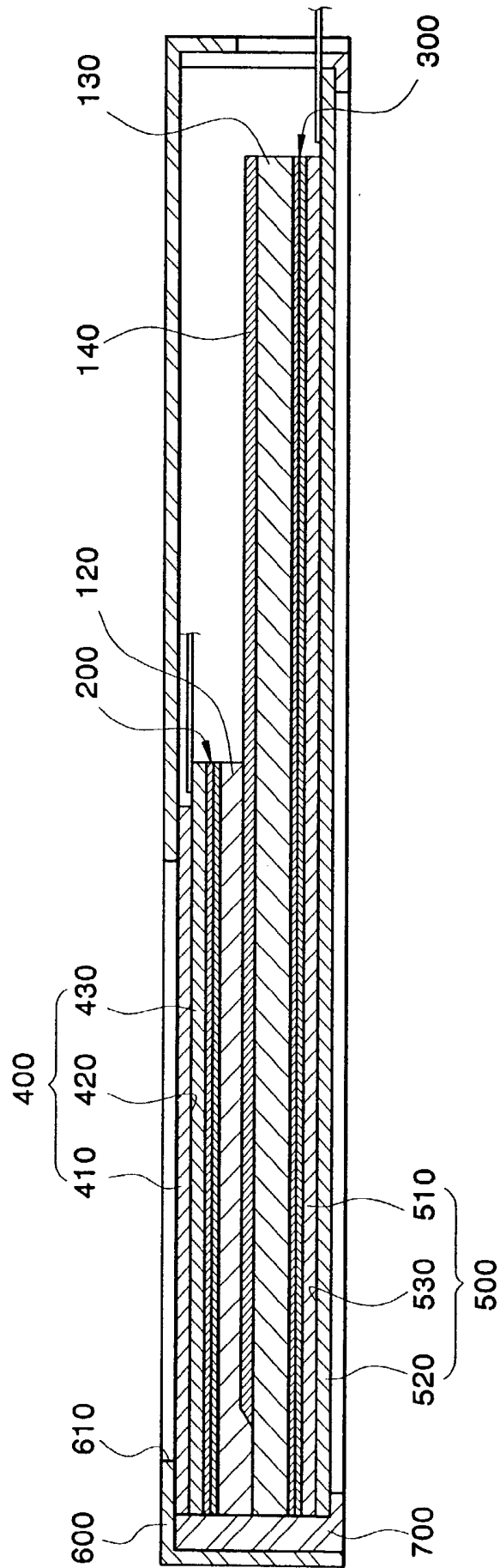

FIG.12



BACKLIGHT ASSEMBLY AND LIQUID CRYSTAL DISPLAY DEVICE USING THE SAME

BACKGROUND OF THE INVENTION

[0001] 1. Field of the Invention

[0002] The disclosure relates to a backlight assembly and a liquid crystal display device using the same. More particularly, the disclosure relates to a backlight assembly and liquid crystal display device using the same in which light generated from a single light source is respectively supplied to two light guiding plates to display two different images, to minimize light loss and to decrease the thickness of elements of the backlight assembly while minimizing the light loss.

[0003] 2. Description of the Related Art

[0004] Generally, liquid crystal is a material in an intermediate state between solid and liquid. As for its electrical property, liquid crystal may change its aligned angle according to an applied electric field. As for its optical property, liquid crystal may change transmissivity thereof according to its aligned angle. The liquid crystal display (LCD) device displays images using these properties of liquid crystal.

[0005] A generalized liquid crystal display device has an LCD panel assembly for controlling the liquid crystal and a backlight assembly for supplying light to the LCD panel assembly.

[0006] The LCD panel assembly includes an LCD panel and a driving module. The LCD panel precisely controls the aligned angle of the liquid crystal in an area ranging from a few μm^2 to a few hundred μm^2 , and the driving module generates driving signals for driving the LCD panel.

[0007] The backlight assembly includes a light source, a light guiding plate, and optical sheets.

[0008] As the light source, either cold cathode fluorescent lamp (CCFL) or light emitting diode (LED) is frequently used because of its long life span, easy manufacturability, and low heat generation. The CCFL is mainly used in large-screen LCD devices, whereas LED is mainly used in small-screen LCD devices.

[0009] The light guiding plate changes the optical distribution of the light generated from the light source and supplies the redistributed light to the LCD panel. Specifically, the light guiding plate changes a line source of light or a point source of light into a surface source of light.

[0010] The optical sheets are installed between the LCD panel assembly and the light guiding plate. The optical sheets make uniform the brightness of the light emitted from the light guiding plate and also control the viewing angle.

[0011] In the conventional LCD device having the above construction, images are displayed while light passes through the light guiding plate, optical sheets and the LCD panel assembly sequentially. As a consequence, image can be displayed only in one direction.

[0012] Recently, an improved LCD device called "dual liquid crystal display device" is disclosed, and the dual liquid crystal display device can overcome the one directional displaying limitation of the conventional LCD device and can display information in two different directions.

[0013] In a conventional dual LCD device, two LCD panels, each performing image display independently, are arranged in an overlapping configuration to display images in two different directions. Specifically, the conventional dual LCD device includes a first LCD device and a second LCD device. The first LCD device includes a first LCD panel, a first light source, a first light guiding plate, first optical sheets, a first light reflective plate and a first receiving container. The second LCD device includes a second LCD panel, a second light source, a second light guiding plate, second optical sheets, a second light reflective plate and a second receiving container.

[0014] The first LCD device displays images in a first direction, and the second LCD device displays images in a second direction.

[0015] The conventional dual LCD device enables displaying images in two different directions, but does so at the expense of other desirable qualities. For example, the extra parts necessary to achieve this dual-display quality increase volume and thickness of the LCD device, making the LCD device bulkier and less desirable.

SUMMARY OF THE INVENTION

[0016] Accordingly, the present invention is provided to substantially obviate one or more problems due to limitations and disadvantages of the related art.

[0017] It is a first feature of the present invention to provide a backlight assembly in which images are displayed in two different directions by using a single light source to decrease the number of elements, volume and weight of the backlight assembly.

[0018] It is a second feature of the invention to provide an LCD device in which images are displayed in two different directions by using a single light source to decrease the number of elements, volume and weight of the LCD device.

[0019] To accomplish the first feature of the invention, the present invention includes a backlight assembly.

[0020] In one aspect of the present invention, the backlight assembly comprises: a first light guiding member including i) a first light incident face onto which a light is incident, ii) a first light exiting face connected to the first light incident face, iii) a first light reflective face portion connected to the first light incident face, a first portion between the first light exiting face and the first light reflective face portion having a first thickness and iv) a second light reflective face portion connected to the first light reflective face portion, a second portion between the first light exiting face and the second light reflective face portion having a second thickness thinner than the first thickness; a second light guiding member being overlapped with the first light guiding member and including i) a second light incident face corresponding to the first light incident face, and onto the second light incident face the light being incident, ii) a second light reflective face, a portion of the second light reflective face being closely in contact with the first light reflective face portion, and a remaining portion of the second light reflective face being spaced apart from the second light reflective face portion by a gap corresponding to a difference between the first thickness and the second thickness to face the second light reflective face portion, and iii) a second light exiting face connected to the second light incident face and facing the

second light reflective face, and a third portion between the second light exiting face and the second light reflective face having a third thickness; a light reflective member interposed between the second light reflective face and the second light reflective face portion to cover the second light reflective face; and a light source for supplying the light to the first and second light incident faces. In another aspect of the present invention, the backlight assembly comprises: a first light guiding member comprising i) a first light incident face, ii) a first light exiting face, and iii) a first light reflective face including a first light reflective face portion and a second light reflective face portion connected to the first light reflective face portion, a first portion between the first light exiting face and the first light reflective face portion having a first thickness, and a second portion between the first light exiting face and the second light reflective face portion having a second thickness thinner than the first thickness; a second light guiding member overlapped with the first light guiding member and comprising i) a second light incident face, ii) a second light exiting face, and iii) a second light reflective face including a third light reflective face portion and a fourth light reflective face portion connected with the third light reflective face portion, a third portion between the second light exiting face and the third light reflective face portion having a third thickness, and a fourth portion between the second light exiting face and the fourth light reflective face portion having a fourth thickness thinner than the third thickness; a light reflective member having a first reflection face arranged at the second light reflective face portion and a second reflection face arranged at the fourth light reflective face portion; and a light source for supplying a light to the first and second light incident faces.

[0021] To accomplish the second feature of the present invention, there is provided a liquid crystal display device comprising: a first light guiding member including i) a first light incident face onto which a light is supplied, ii) a first light exiting face connected to the first light incident face, iii) a first light reflective face portion connected to the first light incident face, a first portion between the first light exiting face and the first light reflective face portion having a first thickness and iv) a second light reflective face portion connected to the first light reflective face portion, a second portion between the first light exiting face and the second light reflective face portion having a second thickness thinner than the first thickness; a second light guiding member being overlapped with the first light guiding member and including i) a second light incident face corresponding to the first light incident face, and onto the second light incident face the light being supplied, ii) a second light reflective face, a portion of the second light reflective face being closely in contact with the first light reflective face portion, and a remaining portion of the second light reflective face being spaced apart from the second light reflective face portion by a gap corresponding to a difference between the first thickness and the second thickness, and iii) a second light exiting face connected to the second light incident face and facing the second light reflective face, and a third portion between the second light exiting face and the second light reflective face having a third thickness; a light reflective member interposed between the second light reflective face and the second light reflective face portion; a light source for supplying the light to the first and second light incident faces; a first display panel facing the first light

exiting face; a second display panel facing the second light exiting face; and a receiving container for fixing the first display panel and the second display panel.

[0022] According to the present invention, two different images can be displayed in two different directions by splitting a light generated from a single light source into two different directions using two light guiding plates. The different images may be displayed simultaneously.

[0023] In addition, light loss due to the reflection plate arranged between two light guiding plates can be minimized to enhance light efficiency and perform a high quality display.

[0024] In addition, the invention provides various effects such as decrease in an overall thickness of the two light guiding plates.

BRIEF DESCRIPTION OF THE DRAWINGS

[0025] The above features and other advantages of the present invention will become more apparent by describing in detail the preferred embodiments thereof with reference to the accompanying drawings, in which:

[0026] FIG. 1 is a perspective view of a backlight assembly according to a first exemplary embodiment of the present invention;

[0027] FIG. 2 is a sectional view taken along the line II-II of FIG. 1;

[0028] FIG. 3 is a sectional view taken along the line III-III of FIG. 1;

[0029] FIG. 4 is a sectional view showing a coupling structure of a first light guiding plate and a second light guiding plate according to a first exemplary embodiment of the present invention;

[0030] FIG. 5 is a sectional view showing a first light guiding plate, a second light guiding plate and a light reflective plate according to a first exemplary embodiment of the present invention;

[0031] FIG. 6 is an enlarged view of the portion "A" in FIG. 5 according to a first exemplary embodiment of the present invention;

[0032] FIG. 7 is an enlarged view of the portion "A" in FIG. 5 and shows a modification in the attachment of the first light guiding plate and the second light guiding plate according to a first exemplary embodiment of the present invention;

[0033] FIG. 8 is an enlarged view of the portion "A" in FIG. 5 and shows another modification in the attachment of the first light guiding plate and the second light guiding plate according to a first exemplary embodiment of the present invention;

[0034] FIG. 9 is a sectional view showing yet another modification in the attachment of the first light guiding plate and the second light guiding plate according to a first exemplary embodiment of the present invention;

[0035] FIG. 10 is a sectional view showing a backlight assembly according to a second exemplary embodiment of the present invention;

[0036] FIG. 11 is an exploded perspective view of a liquid crystal display device according to an exemplary embodiment of the present invention; and

[0037] FIG. 12 is a sectional view taken along the line B-B of FIG. 11 after the liquid crystal display device is assembled.

DETAILED DESCRIPTION OF THE PREFERRED EMBODIMENTS

[0038] Hereinafter, reference will now be made in detail to the preferred embodiments of the present invention, examples of which are illustrated in the accompanying drawings.

[0039] Embodiment 1

[0040] FIG. 1 is a perspective view of a backlight assembly according to a first exemplary embodiment of the present invention.

[0041] Referring to FIG. 1, a backlight assembly 100 includes a light source 110, a first light guiding plate 120, a second light guiding plate 130 and a light reflective plate 140.

[0042] Alternatively, the backlight assembly 100 can further include a receiving container 150 in which the first light guiding plate 120, the second light guiding plate 130, the light reflective plate 140 and the light source are received.

[0043] The light source 110 generates a first light radially. In FIG. 1, the light source 110 may be a point light source such as a light emitting diode. Alternatively, the light source 110 may be a line light source such as a cold cathode fluorescent lamp (CCFL).

[0044] FIG. 2 is a sectional view taken along the line II-II of FIG. 1.

[0045] Referring to FIG. 2, the first light guiding plate 120 has a three-dimensional shape such as a rectangular parallelepiped plate. Specifically, the first light guiding plate 120 has at least three side faces, a top face and a bottom face, wherein the top and the bottom faces are connected with the side faces. For example, the first light guiding plate 120 has four side faces.

[0046] Here, the light source 110 supplies a first light 160 into at least one of the four side faces. Hereinafter, the side face onto which the first light 160 from the light source 110 is supplied is referred to as a first light incident face 121.

[0047] The first light 160 generated from the light source 110 is refracted to change the advancing direction thereof while the first light 160 passes through the first light incident face 121. This is because the first light guiding plate 120 has a different refractive index than air. Hereinafter, the light that has passed through the first light incident face 121 is referred to as a second light 162.

[0048] A first light reflective face 123 reflects the second light 162 toward a first light exiting face to be described later.

[0049] The first light reflective face 123 is comprised of a first light reflective face portion 123a and a second light reflective face portion 123b. The first light reflective face 123 has a first width (W1) and a first length (L1).

[0050] The first light reflective face portion 123a has the first width (W1) and a second length (L2) that is less than the first length (L1) when measured from the first light incident face 121 toward an opposite direction of the first light incident face 121.

[0051] The second light reflective face portion 123b is connected with the first light reflective face portion 123a, and has a third length (L3) that is somewhat shorter than a length remaining after the second length (L2) is subtracted from the first length (L1). The second light reflective face portion 123b lies in a plane that is different from and substantially parallel to the plane of the first light reflective face portion 123a.

[0052] The first light reflective face portion 123a is connected with the second light reflective face portion 123b by an inclined face 123c. The inclined face 123c, i.e., the connecting portion (or stepped portion) has a length that corresponds to a value remaining after the second length (L2) and the third length (L3) are subtracted from the first length (L1).

[0053] The portion of the inclined face 123c that meets the first light reflective face portion 123a and the portion of the inclined face 123c that meets the second light reflective face portion 123b may have smooth curve shapes. This is because the inclined face 123c causes occurrence of discontinuous bright line in the first light guiding plate 120.

[0054] The first light exiting face 125 allows the second light 162 reflected by the first light reflective face portion 123a and the second light reflective face portion 123b of the first light reflective face 123 to be output therethrough. The light output from the first light exiting face 125 proceeds with a different angle from the proceeding direction of the second light 162, and accordingly it is referred to as a third light 164.

[0055] The first light exiting face 125 is in parallel with the first light reflective face portion 123a and the second light reflective face portion 123b. The portion between the first light exiting face 125 and the first light reflective face portion 123a has a first thickness (T1), and the portion between the first light exiting face 125 and the second light reflective face portion 123b has a second thickness (T2) that is thinner than the first thickness (T1).

[0056] FIG. 3 is a sectional view taken along the line III-III of FIG. 1.

[0057] Referring to FIG. 3 and FIG. 1, the second light guiding plate 130 overlies the first light guiding plate 120. The second light guiding plate 130 is similar in shape to the first light guiding plate 120, and has a second width (W2) and a fourth length (L4). The second width (W2) is wider than the first width (W1), and the fourth length (L4) is longer than the first length (L1).

[0058] The second light guiding plate 130 is comprised of a second light incident face 131, a second light reflective face 135 and a second light exiting face 133.

[0059] The second light incident face 131 is arranged such that it does not disaccord with the first light incident face 121 of the first light guiding plate 120. In other words, the second light incident face 131 is aligned with the first light incident face 121 of the first light guiding plate 120 to receive the first light 160. The first light 160 generated from the light source

110 is partially incident onto the second light incident face **131**. Hereinafter, the first light **160** that is incident onto the second light incident face **131** is referred to as a fourth light **166**.

[0060] The second light reflective face **135** connected to the second light incident face **131** faces the first light reflective face portion **123a** and the second light reflective face portion **123b** of the first light guiding plate **120**. The second light reflective face **135** reflects the fourth light **166** to direct the reflected fourth light **166** toward the second light exiting face **133**.

[0061] FIG. 4 is a sectional view showing a coupling structure of a first light guiding plate and a second light guiding plate according to a first exemplary embodiment of the present invention.

[0062] Referring to FIG. 4, the second light reflective face **135** is directly in contact with the first light reflective face portion **123a**. Between the second light reflective face **135** and the second light reflective face portion **123b**, there is a gap (G). In other words, a part of the second light reflective face **135** is spaced apart from the second light reflective face portion **123b** by the gap (G).

[0063] Referring again to FIG. 3, the fourth light **166** reflected by the second light reflective face **135** is directed toward the second light exiting face **133**. Hereinafter, the light output from the second light exiting face **133** is referred to as a fifth light **168**. The second light exiting face **133** faces the second light reflective face **135**. The second light exiting face **133** and the second light reflective face **135** have a uniform third thickness of T3 throughout an entire area of the second light guiding plate **130**. The third thickness (T3) of the second light guiding plate **130** is thinner than the first thickness (T1) of the first light guiding plate **120**.

[0064] FIG. 5 is a sectional view showing a first light guiding plate, a second light guiding plate and a light reflective plate according to a first exemplary embodiment of the present invention.

[0065] Referring to FIG. 1 and FIG. 5, the light reflective plate **140** is interposed between the first light guiding plate **120** and the second light guiding plate **130**. The light reflective plate **140** has a thickness that is equal to the gap between the second light reflective face portion **123b** and the second light reflective face **135**.

[0066] Also, among the edges of the light reflective plate **140**, the edge facing the inclined face **123c** of the first light guiding plate **120** has an inclined face **141** that is designed to fit with the inclined face **123c** so as to be closely in contact with the inclined face **123c**.

[0067] The first light guiding plate **120** and the second light guiding plate **130** are attached to each other by means of an attaching member, which is to prevent the first light guiding plate **120** from getting displaced with respect to the second light guiding plate **130**.

[0068] FIG. 6 is an enlarged view of the portion "A" in FIG. 5 according to a first exemplary embodiment of the present invention.

[0069] Referring to FIG. 6, a double-layered adhesive tape **160** is interposed between the first light reflective face portion **123a** of the first light guiding plate **120** and the

second light reflective face **135** of the second light guiding plate **130** facing the first light reflective face portion **123a**. The double-layered adhesive tape **160** includes a transparent base film **161**, and adhesive layers **162** and **163** coated on both surfaces of the base film **161**.

[0070] FIG. 7 is an enlarged view of the portion "A" in FIG. 5 and shows a modification in the attachment of the first light guiding plate and the second light guiding plate according to a first exemplary embodiment of the present invention.

[0071] Referring to FIG. 7, a thin adhesive layer **170** is interposed between the first light reflective face portion **123a** of the first light guiding plate **120** and the second light reflective face **135** of the second light guiding plate **130** facing the first light reflective face portion **123a**. The thin adhesive layer **170** allows the first light guiding plate **120** and the second light guiding plate **130** to adhere to each other.

[0072] FIG. 8 is an enlarged view of the portion "A" in FIG. 5 and shows another modification in the attachment of the first light guiding plate and the second light guiding plate according to a first exemplary embodiment of the present invention.

[0073] Referring to FIG. 8, at least one adhering protrusion **135a** is formed on the second light reflective face portion **135** of the second light guiding plate **120**. In a state that the first light reflective face portion **123a** of the first light guiding plate **120** is in contact with the adhering protrusion **135a** formed on the second light reflective face **135** of the second light guiding plate **130**, ultrasonic waves or heat is applied to the adhering protrusion **135a**. As a result, the adhering protrusion **135a** is melted and the melted adhering protrusion **135a** allows the first light reflective face portion **123a** and the second light reflective face portion **135** to adhere to each other. The adhering protrusion **135a** is preferably processed to form a minimum gap between the first light reflective face portion **123a** and the second light reflective face **135**.

[0074] FIG. 9 is a sectional view showing yet another modification in the attachment of the first light guiding plate and the second light guiding plate according to a first exemplary embodiment of the present invention.

[0075] Referring to FIG. 9, in a state that the first light guiding plate **120** and the second light guiding plate **130** overlap with each other, some portions of the first light guiding plate **120** may be fixed to the second light guiding plate **130** by means of a transparent clip **180** or the like. Specifically, a portion of the clip **180** presses the first light exiting face **125** of the first light guiding plate **120** against the second light guiding plate **130** and the remainder of the clip **180** presses the second light exiting face **133** of the second light guiding plate **130** against the first light guiding plate **120**.

[0076] The first light guiding plate **120**, the light reflective plate **140**, the second light guiding plate **130** and the light source **110** having the aforementioned coupling structure are received in the receiving container **150** shown in FIG. 1 during the assemblage of the backlight assembly **100**.

[0077] The receiving container **150** encloses the sidewalls of the first light guiding plate **120** and the sidewalls of the

second light guiding plate **130**, and has an opening or an opened bottom face such that the first light exiting face **125** of the first light guiding plate **120** and the second light exiting face **133** of the second light guiding plate **130** are exposed.

[0078] Also, the light source **110** is installed within the receiving container **150** such that the light source **110** faces the first light incident face **121** and the second light incident face **131**.

[0079] Embodiment 2

[0080] FIG. 10 is a sectional view showing a backlight assembly according to a second exemplary embodiment of the present invention.

[0081] Referring to FIG. 10, a backlight assembly **100** includes a light reflective plate **140**, a first light guiding plate **120**, a second light guiding plate **130**, a light source **110** and a receiving container **150**.

[0082] The light reflective plate **140** may be a plate having a predetermined thickness. Also, the light reflective plate **140** is manufactured by coating a material having a high reflectivity on both surfaces of the light reflective plate **140**.

[0083] The light reflective plate **140** has two light reflective faces **143** and **144**. One of the two light reflective faces is the first light reflective face **143** and the other is the second light reflective face **144**.

[0084] The first light guiding plate **120** is arranged to face the first light reflective face **143**, and the second light guiding plate **130** is arranged to face the second light reflective face **144**.

[0085] The first light guiding plate **120** is comprised of a first light incident face **121**, a first light reflective face **123** having a first light reflective face portion **123a** and a second light reflective face portion **123b**, and a first light exiting face **125** facing the first light reflective face **123**. Reference numeral **123c** represents a transitional region between the first light reflective face portion **123a** and the second light reflective face portion **123b**. The transitional region **123c** may have a smooth curve structure or an inclined surface structure.

[0086] A first thickness of T1 between the first light reflective face portion **123a** and the first light exiting face **125** is different from a second thickness of T2 between the second light reflective face portion **123b** and the first light exiting face **125**. Preferably, the first thickness of T1 is greater than the second thickness of T2.

[0087] The first light reflective face **143** of the light reflective plate **140** is laid over the first light guiding plate **120** and aligned with the second light reflective face portion **123b** of the first light guiding plate **120**, so that the overall thickness of the backlight assembly can be decreased.

[0088] The second light guiding plate **130** is comprised of a second light incident face **131**, a second light reflective face **135** having a third light reflective face portion **135a** and a fourth light reflective face portion **135b**, and a second light exiting face **133** facing the second light reflective face **135**. Reference numeral **135c** represents a transitional region between the third light reflective face portion **135a** and the

fourth light reflective face portion **135b**. The transitional region boundary **135c** may have a smooth curve structure or an inclined surface structure.

[0089] A third thickness of T3 between the third light reflective face portion **135a** and the second light exiting face **133** is different from a fourth thickness of T4 between the fourth light reflective face portion **135b** and the second light exiting face **133**. Preferably, the third thickness of T3 is thicker than the fourth thickness of T4.

[0090] The second light reflective face **144** of the light reflective plate **140** is positioned to lie over the second light guiding plate **130** and align with the fourth light reflective face portion **135b**, so that an overall thickness of the backlight assembly can be decreased.

[0091] By the above arrangement, the light reflective plate **130** is interposed between the first light guiding plate **120** and the second light guiding plate **130**.

[0092] The first light guiding plate **120**, the light reflective plate **140**, the second light guiding plate **130** and the light source **110** having the aforementioned coupling structure are installed in the receiving container **150** shown in FIG. 10 during the assemblage of the backlight assembly **100**.

[0093] The receiving container **150** encloses the sidewalls of the first light guiding plate **120** and the sidewalls of the second light guiding plate **130**, and has an opening or an opened bottom face such that the first light exiting face **125** of the first light guiding plate **120** and the second light exiting face **133** of the second light guiding plate **130** are exposed.

[0094] Also, the light source **110** is installed within the receiving container **150** such that the light source **110** faces the first light incident face **121** and the second light incident face **131**.

[0095] Embodiment 3

[0096] FIG. 11 is an exploded perspective view of a liquid crystal display device according to an exemplary embodiment of the present invention; and FIG. 12 is a sectional view taken along the line B-B of FIG. 11 after the liquid crystal display device is assembled.

[0097] Referring to FIG. 11 or FIG. 12, a liquid crystal display device **900** includes a light source **800**, a backlight assembly **100**, optical sheets (**200**, **300**), a first display panel **400**, a second display panel **500** and receiving containers (**600**, **700**).

[0098] The light source **800** generates light radially. The light source **800** may be a line light source such as a cold cathode fluorescent lamp (CCFL) or a point light source such as a light emitting diode.

[0099] The backlight assembly **100** includes a first light guiding plate **120**, a second light guiding plate **130**, and a light reflective plate **140**.

[0100] Since the backlight assembly **100** has the same construction as those of the first and second exemplary embodiment, repeated description thereof will be omitted. Hereinafter, like reference numerals identify identical elements of the backlight assembly **100** throughout the drawings.

[0101] The first display module **400** is installed to face a first light exiting face **125** of the first light guiding plate **120**. The first display module **400** has a plain surface area that is substantially equal to the surface area of the first light exiting face **125**.

[0102] Any construction for the first display module **400** may be allowed as long as the first display module **400** can display images by using the liquid crystal and the light passing through liquid crystal molecules.

[0103] Preferably, the first display module **400** includes a first color filter substrate **410**, a first TFT substrate **430**, and a first liquid crystal **420** interposed between the first color filter substrate **410** and the first TFT substrate **430**.

[0104] The second display module **500** includes a second color filter substrate **520**, a second TFT substrate **510**, and a second liquid crystal **530** interposed between the second color filter substrate **520** and the second TFT substrate **510**. The second display module **500** is installed to face a second light exiting face **133** of the second light guiding plate **130**. The second display module **500** has a surface area that is substantially equal to the area of the second light exiting face **133**. Since the area of the second light exiting face **133** is larger than that of the first light exiting face **125**, the area of the second display module **500** is larger than that of the first display module **400**.

[0105] The optical sheets are comprised of the first optical sheets **200** and the second optical sheets **300**.

[0106] The first optical sheets **200** are installed between the first display module **400** and the first light guiding plate **120**, and the second optical sheets **300** are installed between the second display module **500** and the second light guiding plate **130**.

[0107] In order to enhance light efficiency in the LCD device, each of the first and second optical sheets (**200, 300**) includes at least one sheet. Preferably, each of the first and second optical sheets (**200, 300**) includes a diffusion sheet and a prism sheet. A brightness enhanced film may be further added to the diffusion sheet and the prism sheet.

[0108] The first display module **400**, the optical sheets (**200, 300**), the backlight assembly **100**, and the second display module **500** are received in the receiving containers (**600, 700**).

[0109] The receiving containers (**600, 700**) are comprised of a top chassis **600** and a bottom mold frame **700**. "Top" and "bottom," as used herein, refers to the top and the bottom in reference to the orientation of the figure in **FIG. 11**.

[0110] The bottom mold frame **700** has a square frame structure that is sized to receive four sidewalls of the second light guiding plate **130**.

[0111] The bottom mold frame **700** is comprised of sidewalls only, and allows the second display module **500**, the optical sheets (**200, 300**), the backlight assembly **100** and the first display module **400** to be received therein. The bottom mold frame **700** has a fixing rib **710** which the second display module **500** is hung on and fixed to. Also, in the bottom mold frame **700**, the sidewall adjacent to the first light incident face **121** of the first light guiding plate **120** and the second light incident face **131** of the second light guiding

plate **130** has a light source receiving groove **720** into which the light source **800** is placed.

[0112] The top chassis **600** is coupled with the bottom mold frame **700** to keep the first display module **400** inside the bottom mold frame **700**.

[0113] The top chassis **600** has an opening **610** such that users can view images displayed through the first display module **400**.

[0114] Hereinafter, an assembling method of the LCD device is described.

[0115] First, the first display module **500** for displaying images is placed in the bottom mold frame **700** such that a first face of the first display module **500** faces the inner bottom face of the bottom mold frame **700**, and the first face of the first display module **500** is fixed to the bottom mold frame **700** by using the fixing rib **710**. Then, the second optical sheets **300** are mounted on a second face of the first display module which is the face opposite the first face.

[0116] After the second optical sheets **300** are placed in the bottom mold frame **700**, an assembly including the first light guiding plate **120**, the light reflective plate **140** and the second light guiding plate **130** coupled with each other is mounted on the upper face of the second optical sheets **300**. The second light exiting face **133** of the second light guiding plate **130** is coupled to the bottom mold frame **700** such that the second light exiting face **133** faces the second optical sheets **300**.

[0117] The first optical sheets **200** are closely mounted on the first light guiding plate **120**, and then the first display module **400** is mounted on the first optical sheets **200**.

[0118] After the second display module **500** and the first display module **400** are sequentially placed in the bottom mold frame **700**, the top chassis **600** is coupled with the first display module **400**. The top chassis **600** is coupled with the bottom mold frame **700** while the top chassis **600** presses edges of the first display module **400**.

[0119] While the present invention and its advantages have been described in detail, it should be understood that various changes, substitutions and alterations can be made herein without departing from the spirit and scope of the invention as defined by appended claims.

What is claimed is:

1. A backlight assembly comprising:

a first light guiding member including i) a first light incident face onto which a light is incident, ii) a first light exiting face connected to the first light incident face, iii) a first light reflective face portion connected to the first light incident face, a first portion between the first light exiting face and the first light reflective face portion having a first thickness and iv) a second light reflective face portion connected to the first light reflective face portion, a second portion between the first light exiting face and the second light reflective face portion having a second thickness thinner than the first thickness;

a second light guiding member being overlapped with the first light guiding member and including i) a second light incident face corresponding to the first light incident face, and onto the second light incident face

the light being incident, ii) a second light reflective face, a portion of the second light reflective face being closely in contact with the first light reflective face portion, and a remaining portion of the second light reflective face being spaced apart from the second light reflective face portion by a gap corresponding to a difference between the first thickness and the second thickness to face the second light reflective face portion, and iii) a second light exiting face connected to the second light incident face and facing the second light reflective face, and a third portion between the second light exiting face and the second light reflective face having a third thickness;

a light reflective member interposed between the second light reflective face and the second light reflective face portion to cover the second light reflective face; and

a light source for supplying the light to the first and second light incident faces.

2. The backlight assembly of claim 1, wherein the light source includes a cold cathode fluorescent lamp or a light emitting diode.

3. The backlight assembly of claim 1, wherein the first and second light guiding members are received in a receiving container, the receiving container having an opening through which the first light exiting face of the first light guiding member and the second light exiting face of the second light guiding member are exposed.

4. The backlight assembly of claim 1, wherein the first light reflective face portion and the second light reflective face are attached by means of an attaching member.

5. The backlight assembly of claim 4, wherein the attaching member is one selected from the group consisting of a double-layered adhesive tape, an adhesive and a clip.

6. The backlight assembly of claim 4, wherein the second light reflective face facing the first light reflective face portion has at least one protrusion, and the first light reflective face portion and the second light reflective face are attached by means of the protrusion melted by a heat or ultrasonic waves.

7. The backlight assembly of claim 1, wherein the first thickness of the first light guiding member is no thinner than the third thickness of the second light guiding member.

8. The backlight assembly of claim 1, wherein the first light guiding member has a first surface area and the second light guiding member has a second surface area that is no smaller than the first surface area.

9. The backlight assembly of claim 1, wherein a boundary between the first light reflective face portion and the second light reflective face portion is an inclined face, and an edge of the light reflective member corresponds to the inclined face and has an inverse inclined face such that the edge is closely in contact with the inclined face.

10. A backlight assembly comprising:

a first light guiding member comprising i) a first light incident face, ii) a first light exiting face, and iii) a first light reflective face including a first light reflective face portion and a second light reflective face portion connected to the first light reflective face portion, a first portion between the first light exiting face and the first light reflective face portion having a first thickness, and a second portion between the first light exiting face and the second light reflective face portion having a second thickness thinner than the first thickness;

a second light guiding member overlapped with the first light guiding member and comprising i) a second light incident face, ii) a second light exiting face, and iii) a second light reflective face including a third light reflective face portion and a fourth light reflective face portion connected with the third light reflective face portion, a third portion between the second light exiting face and the third light reflective face portion having a third thickness, and a fourth portion between the second light exiting face and the fourth light reflective face portion having a fourth thickness thinner than the third thickness;

a light reflective member having a first reflection face arranged at the second light reflective face portion and a second reflection face arranged at the fourth light reflective face portion; and

a light source for supplying a light to the first and second light incident faces.

11. A liquid crystal display device comprising:

a first light guiding member including i) a first light incident face onto which a light is supplied, ii) a first light exiting face connected to the first light incident face, iii) a first light reflective face portion connected to the first light incident face, a first portion between the first light exiting face and the first light reflective face portion having a first thickness and iv) a second light reflective face portion connected to the first light reflective face portion, a second portion between the first light exiting face and the second light reflective face portion having a second thickness thinner than the first thickness;

a second light guiding member being overlapped with the first light guiding member and including i) a second light incident face corresponding to the first light incident face, and onto the second light incident face the light being supplied, ii) a second light reflective face, a portion of the second light reflective face being closely in contact with the first light reflective face portion, and a remaining portion of the second light reflective face being spaced apart from the second light reflective face portion by a gap corresponding to a difference between the first thickness and the second thickness, and iii) a second light exiting face connected to the second light incident face and facing the second light reflective face, and a third portion between the second light exiting face and the second light reflective face having a third thickness;

a light reflective member interposed between the second light reflective face and the second light reflective face portion;

a light source for supplying the light to the first and second light incident faces;

a first display panel facing the first light exiting face;

a second display panel facing the second light exiting face; and

a receiving container for fixing the first display panel and the second display panel.

12. The liquid crystal display device of claim 11, wherein the first display panel has a first area that is substantially a same as a second area of the first light exiting face, and the

second display panel has a third area that is substantially a same as a fourth area of the second light exiting face.

13. The liquid crystal display device of claim 11, further comprising a first optical member and a second optical member, the first optical member disposed between the first display panel and the first light exiting face, and the second optical member disposed between the second display panel and the second light exiting face.

14. The liquid crystal display device of claim 11, wherein the second light guiding member further comprises at least one protrusion for attaching the second light reflective face and the first light reflective face portion to each other, the

protrusion is disposed at a portion of the second light reflective face of the second light guiding member, and the portion is in contact with the first light reflective face portion of the first light guiding member.

15. The liquid crystal display device of claim 11, wherein the receiving container comprises a receiving container and a chassis, the receiving container receives the first and second display panels, and the chassis is installed in the receiving container and fixes the first display panel.

* * * * *

专利名称(译)	背光组件和使用该背光组件的液晶显示装置		
公开(公告)号	US20040062027A1	公开(公告)日	2004-04-01
申请号	US10/452319	申请日	2003-05-30
[标]申请(专利权)人(译)	金圭SEOK LEE SOO IK OH JEONG SEOK		
申请(专利权)人(译)	金圭硕 李我洙 OH JEONG-SEOK		
当前申请(专利权)人(译)	金圭硕 李我洙 OH JEONG-SEOK		
[标]发明人	KIM KYU SEOK LEE IK SOO OH JEONG SEOK		
发明人	KIM, KYU-SEOK LEE, IK-SOO OH, JEONG-SEOK		
IPC分类号	G02F1/1333 F21V8/00 F21Y101/02 F21Y103/00 G02F1/13357 G01D11/28		
CPC分类号	G02B6/0088 G02B6/0065		
优先权	1020020058319 2002-09-26 KR		
其他公开文献	US7161644		
外部链接	Espacenet USPTO		

摘要(译)

一种背光组件，包括：第一光导，具有第一光入射面；第一光反射面，连接到第一光入射面并具有台阶部分；以及第一光出射面，面对第一光反射面。所述背光组件还包括第二光导，所述第二光导具有对应于所述第一光入射面的第二光入射面，连接到所述第二光入射面并面向所述第一光反射面的第二光反射面，以及面向所述第二光反射面的第二光出射面第二光反射面。将光反射板插入第一和第二光导之间的间隙中。第一和第二显示板分别安装在第一光导和第二光导上。产生的光被更有效地使用，并且LCD装置的总厚度减小。

