



(19) **United States**

(12) **Patent Application Publication**

(10) **Pub. No.: US 2004/0032388 A1**

Tsai et al.

(43) **Pub. Date:**

Feb. 19, 2004

(54) **BACKLIGHT DEVICE OF A LCD DISPLAY**

Publication Classification

(75) Inventors: **Yi-Hung Tsai**, Hsinchu City (TW);
Hung-Yang Kuo, Hsinchu City (TW);
Shyuan-Jeng Ho, Hsinchu City (TW)

(51) **Int. Cl.⁷** **G09G 3/36**
(52) **U.S. Cl.** **345/102**

Correspondence Address:
BRUCE H. TROXELL
SUITE 1404
5205 LEESBURG PIKE
FALLS CHURCH, VA 22041 (US)

(57) **ABSTRACT**

A many-faceted LCD display, comprising a light guide pipe, a light source, a first optical means, a second optical means, a first LCD panel and a second LCD panel, is disclosed. The light guide pipe comprises a first surface capable and optional of attaching a reflector, a second surface capable and optional of attaching a reflector, a first edge, and a second edge capable and optional of attaching a reflector. The light source is provided at the first edge and capable of generating and emitting light into the light guide pipe. The first optical means is provided on the first surface of the light guide pipe, and the second optical means is provided on the second surface of the light guide pipe. The first LCD panel is provided on the first optical means, and the second LCD panel is provided on the second optical means.

(73) Assignee: **Toppoly Optoelectronics Corp.**

(21) Appl. No.: **10/396,785**

(22) Filed: **Mar. 26, 2003**

(30) **Foreign Application Priority Data**

Aug. 16, 2002 (TW)..... 91118516

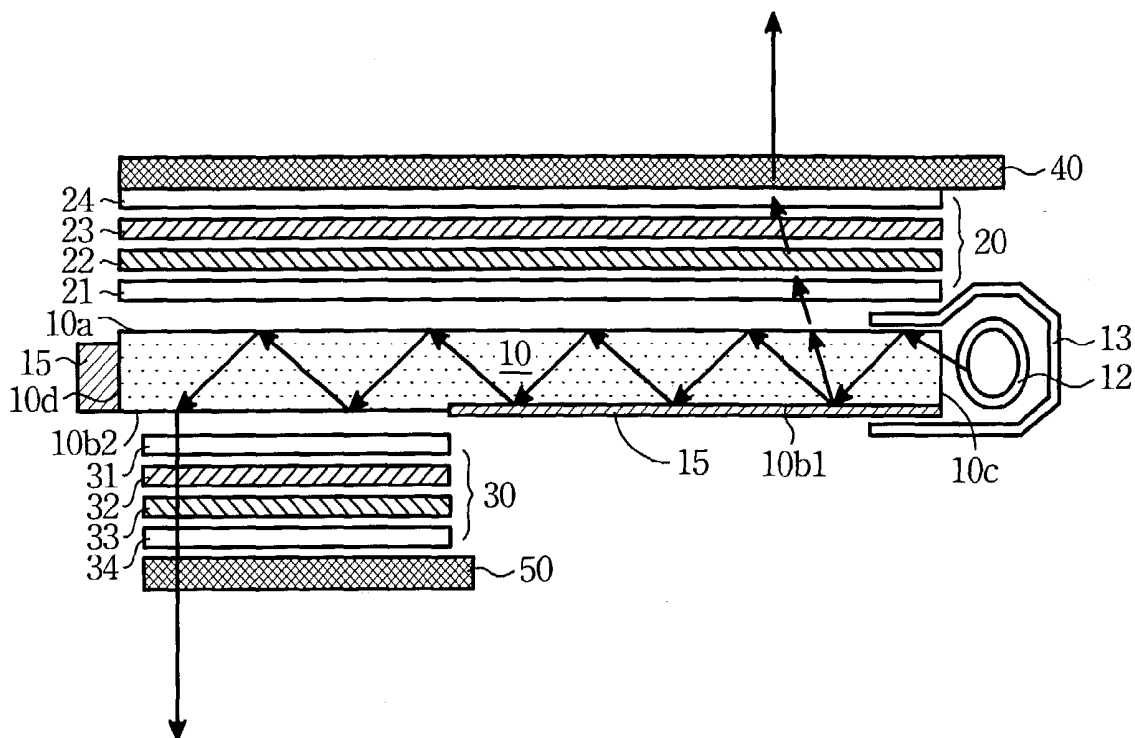

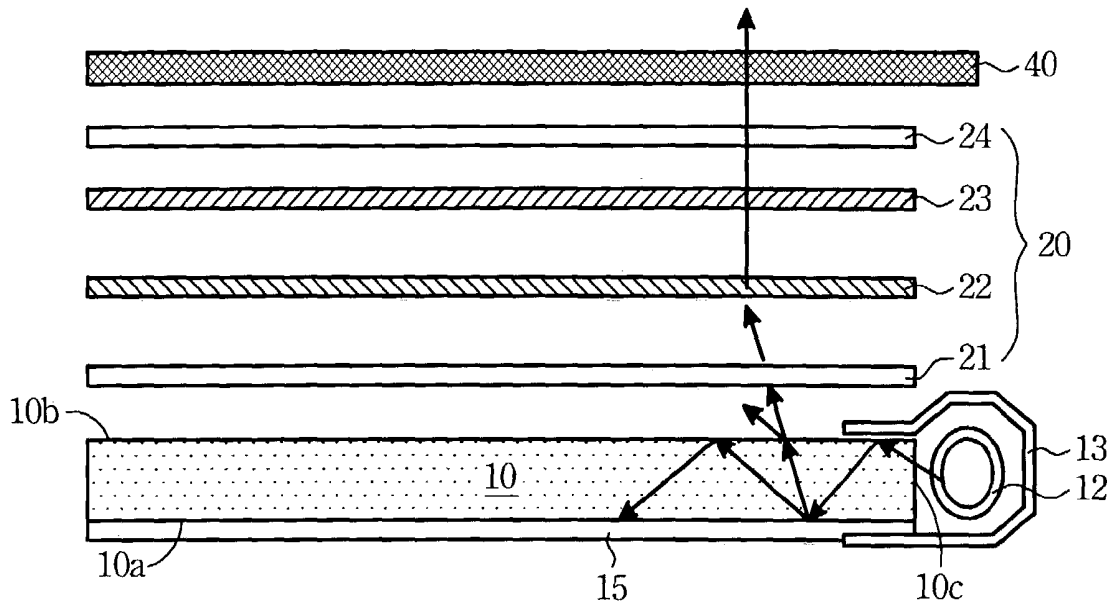

Fig. 1 (Prior Art)

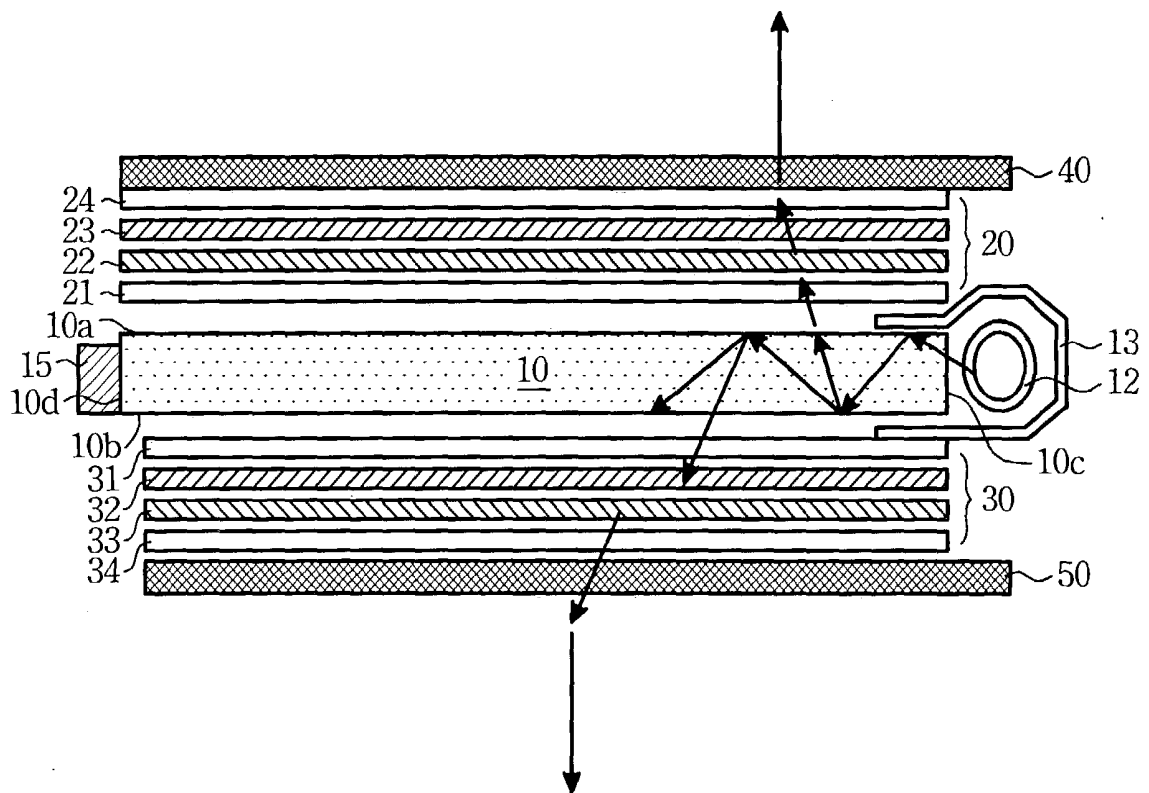

Fig. 2

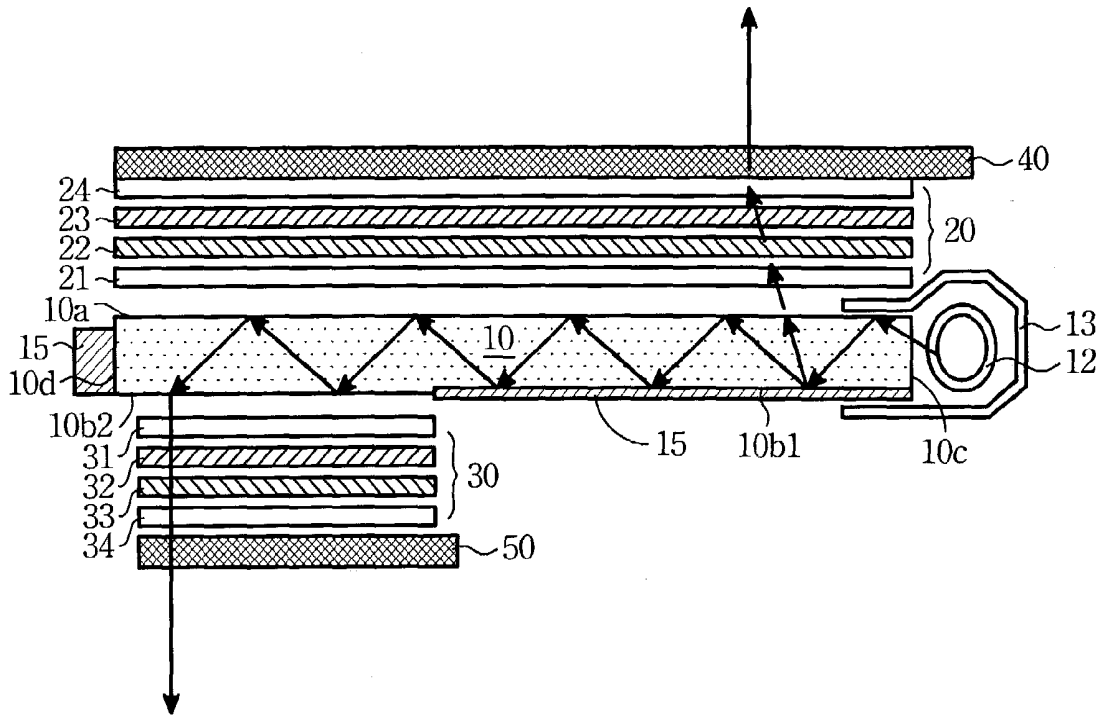

Fig. 3

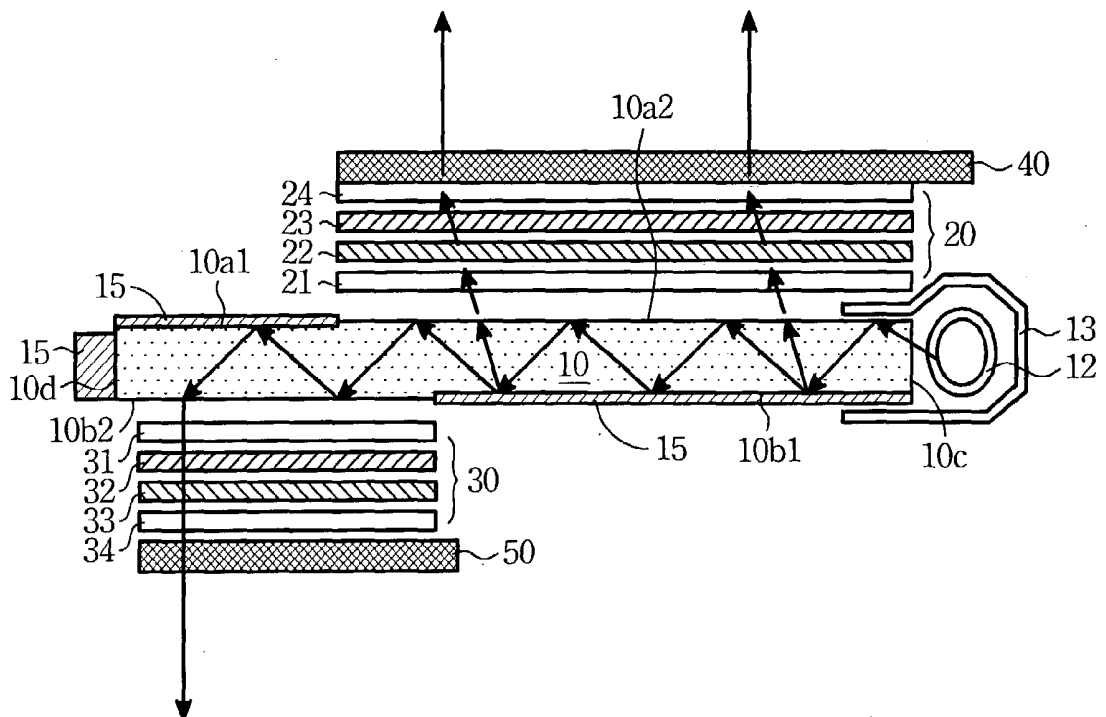

Fig. 4

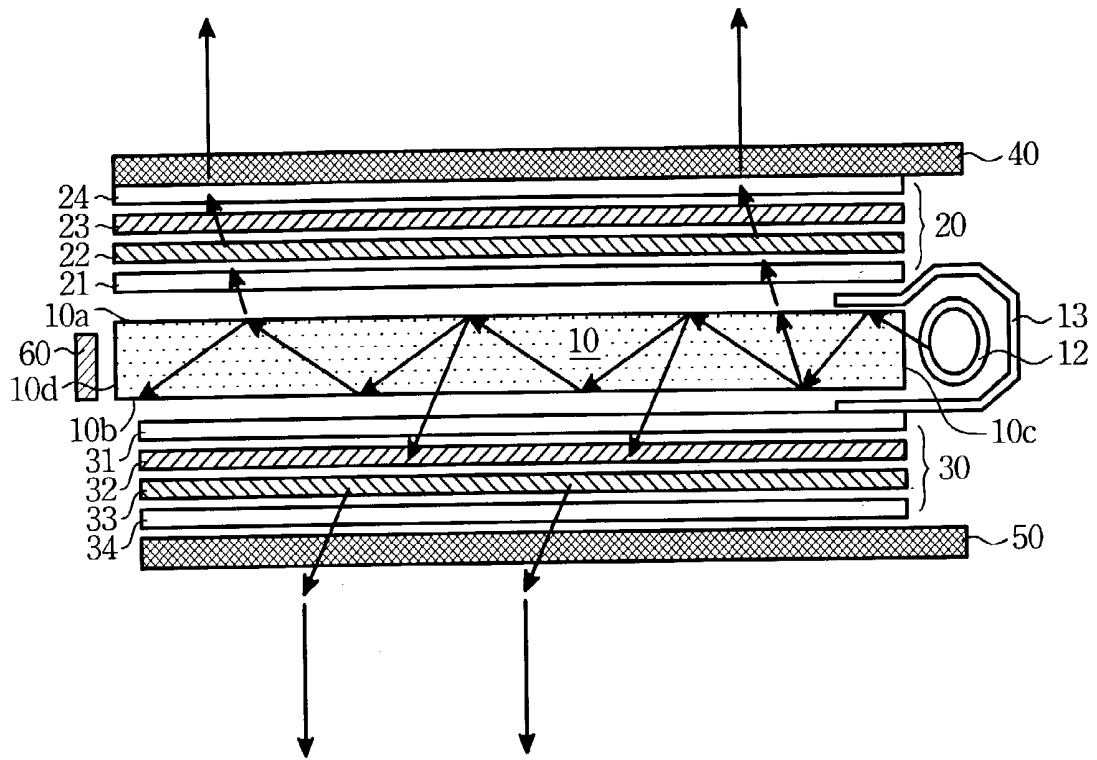

Fig. 5

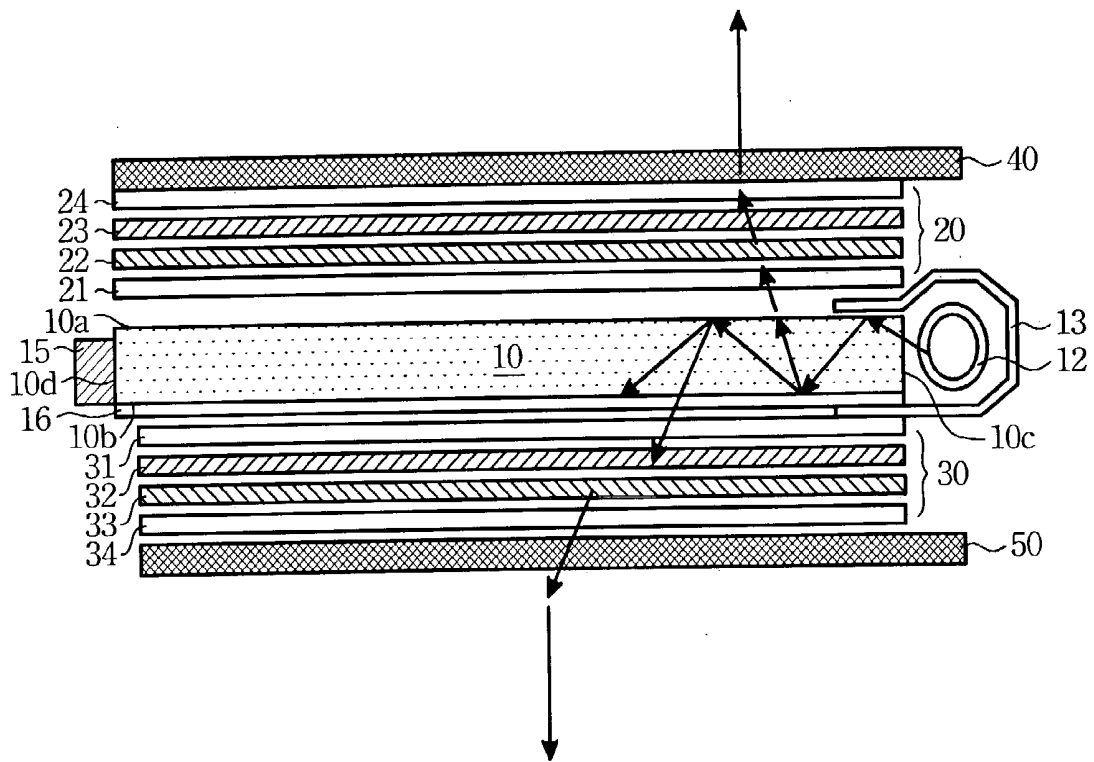

Fig. 6

BACKLIGHT DEVICE OF A LCD DISPLAY

BACKGROUND OF THE INVENTION

[0001] a. Field of the Invention

[0002] The present invention is related to a backlight device of a LCD display, more particularly, to a dual-faceted LCD display or a triple-faceted LCD display with only single backlight device.

[0003] b. Description of Prior Art

[0004] The LCD (Liquid Crystal Display), used as a display device, is mounted in a variety of electronic devices. A laptop (or notebook) personal computer is a typical electronic device employing a large-size liquid display screen. There is competition to develop thinner and lighter screens at larger sizes.

[0005] FIG. 1 shows a cross-sectional view of the conventional LCD display. The LCD display comprises a light guide pipe 10, a light source 12, the first optical means 20, and the first LCD panel 40.

[0006] The light guide pipe 10 is wedge-shaped or plane, comprising the first surface 10a and the second surface 10b. A reflector 15 is provided on the first surface 10a of the light guide pipe 10. The light guide pipe 10 is generally made of an acrylic resin, and has a dot pattern formed on its inner surfaces which can make the light from the light source 12 uniform over the second surface 10b.

[0007] The light source 12, which is a cold fluorescent lamp or any other light emitter such as LED, is provided at the first edge 10c of the light guide pipe 10. The lamp reflector 13 is applied to cover the light source 12 and reflect the light into the light guide pipe 10. The light is then propagated and reflected repeatedly in the light guide pipe 10, and emitted over its second surface 10b.

[0008] The first optical means 20 is provided on the second surface 10b of the light guide pipe 10, and applied to make the light emitted from the light guide pipe 10 uniform. The first optical means 20 is generally composed of the first diffuser 21, the first light converting film 22, the second light converting film 23, and the second diffuser 24. The first LCD panel 40 is then provided on the first optical means 20 for displaying images.

[0009] Recently, more and more electronic products need more than two LCD display, such as a dual-faceted or triple-faceted LCD display on a cell phone or a PDA (Personal Digital Assistant). At present, however, two (three) backlight devices are needed for a dual-faceted (triple-faceted) LCD display. It not only largely increases the cost of production, but also makes the LCD display bulky. It thus violates the trend to make the LCD display thinner and brighter.

[0010] Accordingly, there exists a need in the LCD display field for an improved arrangement which provides a thinner and brighter dual-faceted or triple-faceted LCD display with low production cost.

SUMMARY OF THE INVENTION

[0011] It is an object of the present invention to provide a backlight device of a LCD display.

[0012] It is another object of the present invention to provide a backlight device for a dual-faceted LCD display.

[0013] It is also another object of the present invention to provide a backlight device for a triple-faceted LCD display.

[0014] It is also another object of the present invention to provide a dual-faceted LCD display with only single backlight device.

[0015] It is also another object of the present invention to provide a triple-faceted LCD display with only single backlight device.

[0016] A many-faceted LCD display, comprising a light guide pipe, a light source, a first optical means, a second optical means, a first LCD panel and a second LCD panel, is disclosed. The light guide pipe comprises a first surface capable and optional of attaching a reflector, a second surface capable and optional of attaching a reflector, a first edge, and a second edge capable and optional of attaching a reflector. The light source is provided at the first edge of the light guide pipe and capable of generating and emitting light into the light guide pipe. The first optical means is provided on the first surface of the light guide pipe, and the second optical means is provided on the second surface of the light guide pipe. The first LCD panel is provided on the first optical means, and the second LCD panel is provided on the second optical means.

[0017] In one embodiment of the present invention, there is no reflector provided on the first surface or the second surface of the light guide pipe. Therefore, both the first LCD panel and the second panel can display images with only single light source.

[0018] In another embodiment of the present invention, there is a reflector provided on the first part of the second surface of the light guide pipe, but there is no reflector provided on the first surface of the light guide pipe. Therefore, both the first LCD panel and the second panel can display images with only single light source.

[0019] In another embodiment of the present invention, there is a reflector provided on the first part of the first surface of the light guide pipe, but there is no reflector provided on the second surface of the light guide pipe. Therefore, both the first LCD panel and the second panel can display images with only single light source.

[0020] In another embodiment of the present invention, there is a reflector provided on the first part of the first surface of the light guide pipe, and there is a reflector provided on the first part of the second surface of the light guide pipe. Therefore, both the first LCD panel and the second panel can display images by using only single light source.

[0021] In another embodiment of the present invention, there is a semi-opaque reflector provided on the second surface of the light guide pipe, but there is no reflector provided on the first surface of the light guide pipe. Therefore, both the first LCD panel and the second panel can display images by using only single light source.

[0022] In another embodiment of the present invention, there is no reflector provided on the first surface, the second surface or the second edge of the light guide pipe. Therefore,

all the first LCD panel, the second panel, and the third panel can display images by using only single light source.

BRIEF DESCRIPTION OF THE DRAWINGS

[0023] FIG. 1 shows a cross-sectional view of the conventional LCD display.

[0024] FIG. 2 shows a schematic cross-sectional diagram of the first embodiment of the dual-faceted LCD display of the present invention.

[0025] FIG. 3 shows a schematic cross-sectional diagram of the second embodiment of the dual-faceted LCD display of the present invention.

[0026] FIG. 4 shows a schematic cross-sectional diagram of the third embodiment of the dual-faceted LCD display of the present invention.

[0027] FIG. 5 shows a schematic cross-sectional diagram of the fourth embodiment of the triple-faceted LCD display of the present invention.

[0028] FIG. 6 shows a schematic cross-sectional diagram of the fifth embodiment of the dual-faceted LCD display of the present invention.

DESCRIPTION OF THE PREFERRED EMBODIMENTS

[0029] The present invention is related to a backlight device of a LCD display, more particularly, to a dual-faceted LCD display or a triple-side LCD display by using a single backlight device. The key feature of the present invention is to direct the light emitted from a single backlight device to two or more directions.

[0030] The backlight device of the present invention can be applied to any kind of LCD device, such as TFT-LCD or STN-LCD, and so on. The backlight device of the present invention can be applied to any kind of electronic products, such as Notebook computers or PDAs (Personal Digital Assistants), and so on.

[0031] Please refer first to FIG. 2, which is a schematic cross-sectional diagram of the first embodiment of the dual-faceted LCD display of the present invention. The dual-faceted LCD display is composed of a light guide pipe 10, a light source 12, a first optical means 20, a second optical means 30, a first LCD panel 40, and a second LCD panel 50.

[0032] The light guide pipe 10 is wedge-shaped or plane, comprising a first surface 10a, a second surface 10b, a first edge 10c, and a second edge 10d. According to the present invention, people can optionally choose whether a reflector 15 is attached on the first surface 10a, the second surface 10b, or the second edge 10d of the light guide pipe 10 or not. In other word, each one of the first surface 10a, the second surface 10b, and the second edge 10d of the light guide pipe 10 is capable and optional of attaching a reflector, depending on people's choice. The light guide pipe 10 is generally made of an acrylic resin or the like, and has a dot pattern formed on its inner surfaces which can make the light from the light source 12 uniform over the first surface 10a and the second surface 10b.

[0033] The light source 12, which is a cold fluorescent lamp or any other light emitter such as LED, is provided at

the first edge 10c of the light guide pipe 10. The lamp reflector 13 is applied to cover the light source 12 and reflect the light into the light guide pipe 10.

[0034] In the first embodiment of the present invention, there is no reflector 15 provided on the first surface 10a or the second surface 10b of the light guide pipe 10, but there is one reflector provided on the second edge 10d of the light guide pipe 10. Therefore, the light from the light source 12 is propagated and reflected repeatedly in the light guide pipe 10, and then emitted over its first surface 10a and second surface 10b both.

[0035] The first optical means 20 is provided on the first surface 10a of the light guide pipe 10, and applied to make the light emitted from the light guide pipe 10 uniform. The first optical means 20 is generally composed of a first diffuser 21, a first light converting film 22, a second light converting film 23, and a second diffuser 24. The first diffuser 21 and the second diffuser 24 are made of a polymer film or the like for diffusing the light. The first light converting film 22 and the second light converting film 23 are prisms which can convert and focus the light.

[0036] The second optical means 30 is provided on the second surface 10b of the light guide pipe 10, and applied to make the light emitted from the light guide pipe 10 uniform. The second optical means 30 is generally composed of a first diffuser 31, a first light converting film 32, a second light converting film 33, and a second diffuser 34. The first diffuser 31 and the second diffuser 34 are made of a polymer film or the like for diffusing the light. The first light converting film 32 and the second light converting film 33 are prisms which can convert and focus the light.

[0037] The first LCD panel 40 is provided on the first optical means 20 and served as the first monitor. On the other side, the second LCD panel 50 is provided on the second optical means 30 and served as the second monitor. According to the present embodiment, there is no reflector 15 provided on the first surface 10a or the second surface 10b of the light guide pipe 10, so the light from the light source 12 can be emitted from the first surface 10a and the second surface 10b both. Therefore, both the first LCD panel 40 and the second panel 50 can display images.

[0038] Please refer then to FIG. 3, which is one schematic cross-sectional diagram of the second preferred embodiment of the dual-faceted LCD display of the present invention. The dual-faceted LCD display in this embodiment is composed of a light guide pipe 10, a light source 12, a first optical means 20, a second optical means 30, a first LCD panel 40, and a second LCD panel 50.

[0039] The light guide pipe 10 is wedge-shaped or plane, comprising a first surface 10a, a second surface 10b, a first edge 10c, and a second edge 10d. According to the present invention, people can choose whether a reflector 15 is provided on the first surface 10a, the second surface 10b, or the second edge 10d of the light guide pipe 10 or not. In other word, each one of the first surface 10a, the second surface 10b, and the second edge 10d of the light guide pipe 10 is capable and optional of attaching a reflector, depending on people's choice. The light guide pipe 10 is generally made of an acrylic resin or the like, and has a dot pattern formed on its inner surfaces which can make the light from the light source 12 uniform over the first surface 10a and the second surface 10b.

[0040] The light source **12**, which is a cold fluorescent lamp or any other light emitter such as LED, is provided at the first edge **10c** of the light guide pipe **10**. The lamp reflector **13** is applied to cover the light source **12** and reflect the light into the light guide pipe **10**.

[0041] In the second embodiment of the present invention, there is no reflector **15** provided on the first surface **10a** of the light guide pipe **10**. However, on the other hand, there is one reflector **15** provided on the first part **10b1** of the second surface **10b** of the light guide pipe **10**. Furthermore, there is also one reflector **15** provided on the second edge **10d** of the light guide pipe **10**. Therefore, the light from the light source **12** is propagated and reflected repeatedly in the light guide pipe **10**, and emitted over the first surface **10a** and the second part **10b2** of the second surface **10b**.

[0042] The first optical means **20** is provided on the first surface **10a** of the light guide pipe **10**, and applied to make the light emitted from the light guide pipe **10** uniform. The first optical means **20** is generally composed of a first diffuser **21**, a first light converting film **22**, a second light converting film **23**, and a second diffuser **24**. The first diffuser **21** and the second diffuser **24** are made of a polymer film or the like for diffusing the light. The first light converting film **22** and the second light converting film **23** are prisms which can convert and focus the light. The second optical means **30** is provided on the second part **10b2** of the second surface **10b** of the light guide pipe **10**, and applied to make the light emitted from the light guide pipe **10** uniform. The second optical means **30** is generally composed of a first diffuser **31**, a first light converting film **32**, a second light converting film **33**, and a second diffuser **34**. The first diffuser **31** and the second diffuser **34** are made of a polymer film or the like for diffusing the light. The first light converting film **32** and the second light converting film **33** are prisms which can convert and focus the light.

[0043] The first LCD panel **40** is provided on the first optical means **20** and served as the first monitor. On the other side, the second LCD panel **50** is provided on the second optical means **30** and served as the second monitor. According to the present embodiment, there is no reflector **15** provided on the first surface **10a** or the second part **10b2** of the second surface **10b**, so the light from the light source **12** can be emitted from the first surface **10a** and the second part **10b2** of the second surface **10b** both. Therefore, both the first LCD panel **40** and the second panel **50** can display images.

[0044] Please refer now to FIG. 4, which is a schematic cross-sectional diagram of the third embodiment of the dual-faceted LCD display of the present invention. The dual-faceted LCD display is composed of a light guide pipe **10**, a light source **12**, a first optical means **20**, a second optical means **30**, a first LCD panel **40**, and a second LCD panel **50**.

[0045] The light guide pipe **10** is wedge-shaped or plane, comprising a first surface **10a**, a second surface **10b**, a first edge **10c**, and a second edge **10d**. According to the present invention, people can choose whether a reflector **15** is provided on the first surface **10a**, the second surface **10b**, or the second edge **10d** of the light guide pipe **10** or not. In other word, each one of the first surface **10a**, the second surface **10b**, and the second edge **10d** of the light guide pipe **10** is capable and optional of attaching a reflector, depending on people's choice. The light guide pipe **10** is generally

made of an acrylic resin or the like, and has a dot pattern formed on its inner surfaces which can make the light from the light source **12** uniform over the first surface **10a** and the second surface **10b**.

[0046] The light source **12**, which is a cold fluorescent lamp or any other light emitter such as LED, is provided at the first edge **10c** of the light guide pipe **10**. The lamp reflector **13** is applied to cover the light source **12** and reflect the light into the light guide pipe **10**.

[0047] In the third embodiment of the present invention, there is no reflector **15** provided on the second part **10a2** of the first surface **10a** or the second part **10b2** of the second surface **10b** of the light guide pipe **10**. However, on the other hand, one reflector **15** is provided on each of the first part **10a1** of the first surface **10a**, the first part **10b1** of the second surface **10b** and the second edge **10d** of the light guide pipe **10**. Therefore, the light from the light source **12** is propagated and reflected repeatedly in the light guide pipe **10**, and then emitted over the second part **10a2** of the first surface **10a** and the second part **10b2** of the second surface **10b**.

[0048] The first optical means **20** is provided on the second part **10a2** of first surface **10a** of the light guide pipe **10**, and applied to make the light emitted from the light guide pipe **10** uniform. The first optical means **20** is generally composed of a first diffuser **21**, a first light converting film **22**, a second light converting film **23**, and a second diffuser **24**. The first diffuser **21** and the second diffuser **24** are made of a polymer film or the like for diffusing the light. The first light converting film **22** and the second light converting film **23** are prisms which can convert and focus the light. The second optical means **30** is provided on the second part **10b2** of the second surface **10b** of the light guide pipe **10**, and applied to make the light emitted from the light guide pipe **10** uniform. The second optical means **30** is generally composed of a first diffuser **31**, a first light converting film **32**, a second light converting film **33**, and a second diffuser **34**. The first diffuser **31** and the second diffuser **34** are made of a polymer film or the like for diffusing the light. The first light converting film **32** and the second light converting film **33** are prisms which can convert and focus the light.

[0049] The first LCD panel **40** is provided on the first optical means **20** and served as the first monitor. On the other side, the second LCD panel **50** is provided on the second optical means **30** and served as the second monitor. According to the present embodiment, because there is no reflector **15** provided on the second part **10a2** of first surface **10a** or the second part **10b2** of the second surface **10b**, the light from the light source **12** can be emitted from the second part **10a2** of the first surface **10a** and the second part **10b2** of the second surface **10b** both. Therefore, both the first LCD panel **40** and the second panel **50** can display images.

[0050] Please refer then to FIG. 5, which is a schematic cross-sectional diagram of the fourth embodiment of the triple-faceted LCD display of the present invention. The dual-faceted LCD display of this embodiment is composed of a light guide pipe **10**, a light source **12**, a first optical means **20**, a second optical means **30**, a first LCD panel **40**, a second LCD panel **50**, and a third LCD panel **60**.

[0051] The light guide pipe **10** is wedge-shaped or plane, comprising a first surface **10a**, a second surface **10b**, a first

edge **10c**, and a second edge **10d**. According to the present invention, people can choose whether a reflector **15** is provided on the first surface **10a**, the second surface **10b**, or the second edge **10d** of the light guide pipe **10** or not. In other word, each one the first surface **10a**, the second surface **10b**, and the second edge **10d** of the light guide pipe **10** is capable and optional of attaching a reflector, depending on people's choice. The light guide pipe **10** is generally made of an acrylic resin or the like, and has a dot pattern formed on its inner surfaces which can make the light from the light source **12** uniform over the first surface **10a** and the second surface **10b** of the light guide pipe **10**.

[0052]). The light source **12**, which is a cold fluorescent lamp or any other light emitter such as LED, is provided at the first edge **10c** of the light guide pipe **10**. The lamp reflector **13** is applied to cover the light source **12** and reflect the light into the light guide pipe **10**.

[0053] In the fourth embodiment of the present invention, there is no reflector **15** provided on the first surface **10a**, and there is no reflector **15** provided on the second surface **10b**, either. Furthermore, no reflector is provided on the second edge **10d** of the light guide pipe **10**, either. Therefore, the light from the light source **12** is propagated and reflected repeatedly in the light guide pipe **10**, and then emitted over its first surface **10a**, its second surface **10b**, and its second edge **10d**.

[0054] The first optical means **20** is provided on the first surface **10a** of the light guide pipe **10**, and applied to make the light emitted from the light guide pipe **10** uniform. The first optical means **20** is generally composed of a first diffuser **21**, a first light converting film **22**, a second light converting film **23**, and a second diffuser **24**. The first diffuser **21** and the second diffuser **24** are made of a polymer film or the like for diffusing the light. The first light converting film **22** and the second light converting film **23** are prisms or the like which can convert and focus the light.

[0055] The second optical means **30** is provided on the second surface **10b** of the light guide pipe **10**, and applied to make the light emitted from the light guide pipe **10** uniform. The second optical means **30** is generally composed of a first diffuser **31**, a first light converting film **32**, a second light converting film **33**, and a second diffuser **34**. The first diffuser **31** and the second diffuser **34** are made of a polymer film or the like for diffusing the light. The first light converting film **32** and the second light converting film **33** are prisms which can convert and focus the light.

[0056] The first LCD panel **40** is provided on the first optical means **20** and served as the first monitor. On the other side, the second LCD panel **50** is provided on the second optical means **30** and served as the second monitor. The third LCD panel **60** is provided on the second edge **10d** of the light guide pipe **10** and served as the third monitor. Furthermore, a third optical means (not shown in the figure) can further be provided between the third LCD panel **60** and the second edge **10d** of the light guide pipe **10**.

[0057] According to the present embodiment, because there is no reflector **15** provided on the first surface **10a**, the second surface **10b** or the second edge **10d**, the light from the light source **12** can be emitted from the first surface **10a**, the second surface **10b**, and the second edge **10d**. Therefore, each one of the first LCD panel **40**, the second panel **50**, and the third panel **60** can display images.

[0058] Please refer finally to **FIG. 6**, which is a schematic cross-sectional diagram of the fifth embodiment of the dual-faceted LCD display of the present invention. The dual-faceted LCD display is composed of a light guide pipe **10**, a light source **12**, a first optical means **20**, a second optical means **30**, a first LCD panel **40**, and a second LCD panel **50**.

[0059] The light guide pipe **10** is wedge-shaped or plane, comprising a first surface **10a**, a second surface **10b**, a first edge **10c**, and a second edge **10d**. According to the present invention, people can choose whether a reflector **15** is provided on the first surface **10a**, the second surface **10b**, or the second edge **10d** of the light guide pipe **10** or not. In other word, each one of the first surface **10a**, the second surface **10b**, and the second edge **10d** of the light guide pipe **10** is capable and optional of attaching a reflector, depending on people's choice. The light guide pipe **10** is generally made of an acrylic resin or the like, and has a dot pattern formed on its inner surfaces which can make the light from the light source **12** uniform over the first surface **10a** and the second surface **10b**.

[0060] The light source **12**, which is a cold fluorescent lamp or any other light emitter such as LED, is provided at the first edge **10c** of the light guide pipe **10**. The lamp reflector **13** is applied to cover the light source **12** and reflect the light into the light guide pipe **10**.

[0061] In the fifth embodiment of the present invention, there is no reflector **15** provided on the first surface **10a**, but there is one reflector provided on the second edge **10d** of the light guide pipe **10**. Particularly, one semi-opaque reflector **16** is provided on the second surface **10b** of the light guide pipe **10**. Therefore, the light from the light source **12** is propagated and reflected repeatedly in the light guide pipe **10**, and emitted over its first surface **10a** and second surface **10b** both.

[0062] The first optical means **20** is provided on the first surface **10a** of the light guide pipe **10**, and applied to make the light emitted from the light guide pipe **10** uniform. The first optical means **20** is generally composed of a first diffuser **21**, a first light converting film **22**, a second light converting film **23**, and a second diffuser **24**. The first diffuser **21** and the second diffuser **24** are made of a polymer film or the like for diffusing the light. The first light converting film **22** and the second light converting film **23** are prisms or the like which can convert and focus the light.

[0063] The second optical means **30** is provided on the second surface **10b** of the light guide pipe **10**, and applied to make the light emitted from the light guide pipe **10** uniform. The second optical means **30** is generally composed of a first diffuser **31**, a first light converting film **32**, a second light converting film **33**, and a second diffuser **34**. The first diffuser **31** and the second diffuser **34** are made of a polymer film for diffusing the light. The first light converting film **32** and the second light converting film **33** are prisms or the like which can convert and focus the light.

[0064] The first LCD panel **40** is provided on the first optical means **20** and served as the first monitor. On the other side, the second LCD panel **50** is provided on the second optical means **30** and served as the second monitor. According to the present embodiment, because there is no reflector **15** provided on the first surface **10a** but there is one

semi-opaque reflector **16** provided on the second surface **10b** of the light guide pipe **10**, the light from the light source **12** can be emitted from the first surface **10a** and the second surface **10b** both. Therefore, both the first LCD panel **40** and the second panel **50** can display images.

[0065] The many features and advantages of the invention are apparent from the detailed specification, and thus, it is intended by the appended claims to cover all such features and advantages of the invention which fall within the true spirit and scope of the invention. Further, since numerous modifications and variations will readily occur to those skilled in the art, it is not desired to limit the invention to the exact construction and operation illustrated and described, and accordingly, all suitable modifications and equivalents may be resorted to, falling within the scope of the invention.

What is claimed is:

1. A backlight device of a LCD display, comprising:

a light guide pipe, which comprises a first surface capable and optional of attaching a reflector and a second surface capable and optional of attaching a reflector;

a light source, which is capable of generating and emitting light into said light guide pipe;

a first optical means, which is provided on said first surface of said light guide pipe; and

a second optical means, which is provided on said second surface of said light guide pipe.

2. The backlight device of a LCD display of claim 1, wherein both said first optical means and said second optical means are composed of a first diffuser, a first light converting film, a second light converting film, and a second diffuser.

3. The backlight device of a LCD display of claim 1, wherein there is no reflector provided on said first surface of said light guide pipe or said second surface of said light guide pipe.

4. The backlight device of a LCD display of claim 1, wherein there is one reflector provided on a first part of said second surface of said light guide pipe, but there is no reflector provided on said first surface of said light guide pipe.

5. The backlight device of a LCD display of claim 1, wherein there is one reflector provided on a first part of said first surface of said light guide pipe, but there is no reflector provided on said second surface of said light guide pipe.

6. The backlight device of a LCD display of claim 1, wherein there is one reflector provided on a first part of said first surface of said light guide pipe, and there is one reflector provided on a first part of said second surface of said light guide pipe.

7. The backlight device of a LCD display of claim 1, wherein there is one semi-opaque reflector provided on said second surface of said light guide pipe, but there is no reflector provided on said first surface of said light guide pipe.

8. A backlight device of a LCD display, comprising:

a light guide pipe, which comprises a first surface capable and optional of attaching a reflector, a second surface capable and optional of attaching a reflector, a first edge, and a second edge capable and optional of attaching a reflector;

a light source, which is provided at said first edge and capable of generating and emitting light into said light guide pipe;

a first optical means, which is provided on said first surface of said light guide pipe; and

a second optical means, which is provided on said second surface of said light guide pipe.

9. The backlight device of a LCD display of claim 8, wherein both said first optical means and said second optical means are composed of a first diffuser, a first light converting film, a second light converting film, and a second diffuser.

10. The backlight device of a LCD display of claim 8, wherein there is no reflector provided on said first surface of said light guide pipe, said second surface of said light guide pipe or said second edge of said light guide pipe.

11. A many-faceted LCD display, comprising:

a light guide pipe, which comprises a first surface capable and optional of attaching a reflector, a second surface capable and optional of attaching a reflector, a first edge, and a second edge capable and optional of attaching a reflector;

a light source, which is provided at said first edge and capable of generating and emitting light into said light guide pipe;

a first optical means, which is provided on said first surface of said light guide pipe; and

a second optical means, which is provided on said second surface of said light guide pipe;

a first LCD panel, which is provided on said first optical means; and

a second LCD panel, which is provided on said second optical means.

12. The many-faceted LCD display of claim 11, wherein both said first optical means and said second optical means are composed of a first diffuser, a first light converting film, a second light converting film, and a second diffuser.

13. The many-faceted LCD display of claim 11, wherein there is no reflector provided on said first surface or said second surface of said light guide pipe.

14. The many-faceted LCD display of claim 11, wherein there is one reflector provided on a first part of said second surface of said light guide pipe, but there is no reflector provided on said first surface of said light guide pipe.

15. The many-faceted LCD display of claim 11, wherein there is one reflector provided on a first part of said first surface of said light guide pipe, but there is no reflector provided on said second surface of said light guide pipe.

16. The many-faceted LCD display of claim 11, wherein there is one reflector provided on a first part of said first surface of said light guide pipe, and there is a reflector provided on a first part of said second surface of said light guide pipe.

17. The many-faceted LCD display of claim 11, wherein there is one semi-opaque reflector provided on said second surface of said light guide pipe, but there is no reflector provided on said first surface of said light guide pipe.

18. The many-faceted LCD display of claim 11, wherein there is no reflector provided on said first surface of said light guide pipe, said second surface of said light guide pipe or said second edge of said light guide pipe.

19. The many-faceted LCD display of claim 18, further comprising a third LCD panel, which is provided on said second edge.

20. The many-faceted LCD display of claim 19, further comprising a third optical means, which is provided between said third LCD panel and said second edge of said light guide pipe.

* * * * *

专利名称(译)	LCD显示器的背光装置		
公开(公告)号	US20040032388A1	公开(公告)日	2004-02-19
申请号	US10/396785	申请日	2003-03-26
[标]申请(专利权)人(译)	统宝光电股份有限公司		
申请(专利权)人(译)	统宝光电股份有限公司.		
当前申请(专利权)人(译)	群创光电		
[标]发明人	TSAI YI HUNG KUO HUNG YANG HO SHYUAN JENG		
发明人	TSAI, YI-HUNG KUO, HUNG-YANG HO, SHYUAN-JENG		
IPC分类号	G02F1/1333 F21V8/00 F21Y103/00 G02F1/1335 G02F1/13357 G09G3/36		
CPC分类号	G02F1/133615 Y10S385/901 G02F2001/133342		
优先权	091118516 2002-08-16 TW		
其他公开文献	US7184007		
外部链接	Espacenet USPTO		

摘要(译)

本发明公开了一种多面LCD显示器，包括光导管，光源，第一光学装置，第二光学装置，第一LCD面板和第二LCD面板。光导管包括第一表面和第二表面，第一表面能够并且可选地附接反射器，第二表面能够并且可选地附接反射器，第一边缘和第二边缘能够并且可选地附接反射器。光源设置在第一边缘处并且能够产生光并将光发射到光导管中。第一光学装置设置在光导管的第一表面上，第二光学装置设置在光导管的第二表面上。第一LCD面板设置在第一光学装置上，第二LCD面板设置在第二光学装置上。

