



US 20050024565A1

(19) **United States**

(12) **Patent Application Publication** (10) **Pub. No.: US 2005/0024565 A1**

Hwang et al.

(43) **Pub. Date:**

Feb. 3, 2005

(54) **LIQUID CRYSTAL DISPLAY DEVICE**

(52) **U.S. Cl.** 349/119

(76) Inventors: **In-Sun Hwang**, Suwon-si (KR);
Yamamura Nobuyuki, Seoul (KR);
Sang-Il Kim, Suwon-si (KR)

(57) **ABSTRACT**

Correspondence Address:
McGuireWoods LLP
Suite 1800
1750 Tysons Boulevard
McLean, VA 22102 (US)

Disclosed are an apparatus for changing a pathway of light according to a visual field angle to relax a gray scale inversion and for use in a liquid crystal display device in a twisted nematic mode, and the liquid crystal display device having the same. The light pathway partially changing apparatus is disposed on a liquid crystal display panel changes the pathway of the light partially so that a part of the light is substantially transmitted in the same direction as the light proceeds while the rest of the light is transmitted through a changed pathway, in order to change a brightness of the light according to a visual field angle of a liquid crystal display panel to restrain a gray scale inversion of the images while the light passes through the liquid crystal display panel to make the images on the liquid crystal display panel. The rest of the light transmitted through the changed pathway causes to, obtain the visual field angle of the liquid crystal display panel, while restrains the gray scale inversion of the images along with the part of the light passing through the liquid crystal display panel in the same direction as that of the light transmitted through a center of the liquid crystal display panel.

(21) Appl. No.: **10/846,993**

(22) Filed: **May 17, 2004**

Related U.S. Application Data

(63) Continuation of application No. 09/848,618, filed on Jul. 10, 2001, now Pat. No. 6,738,118.

(30) **Foreign Application Priority Data**

Mar. 17, 2001 (KR) 2001-13875

Publication Classification

(51) **Int. Cl.⁷** **G02F 1/1335**

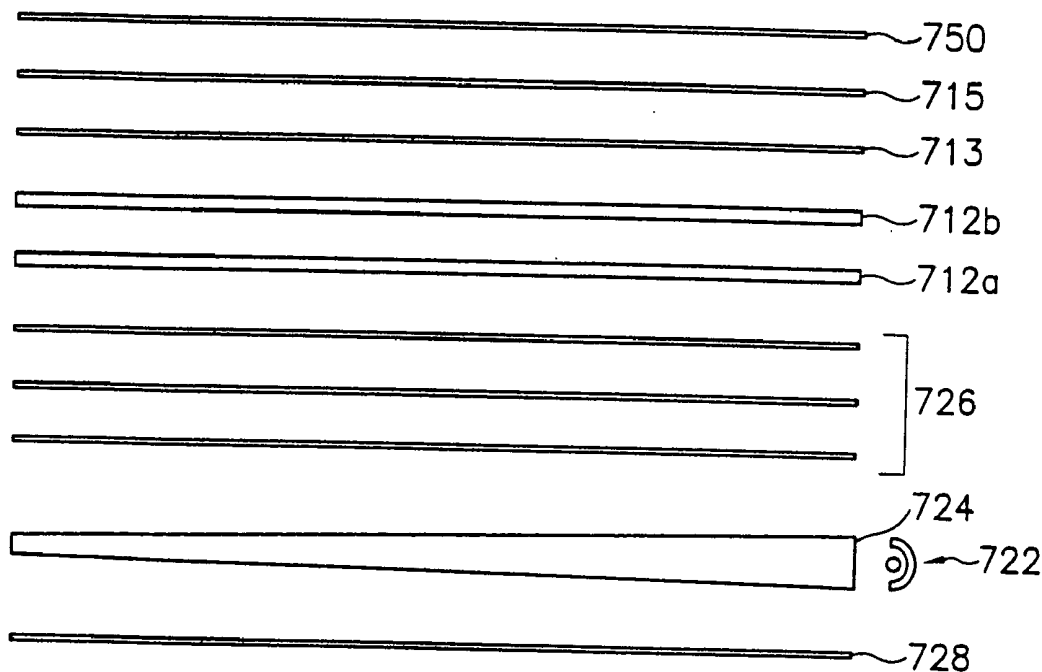

FIG. 1
(PRIOR ART)

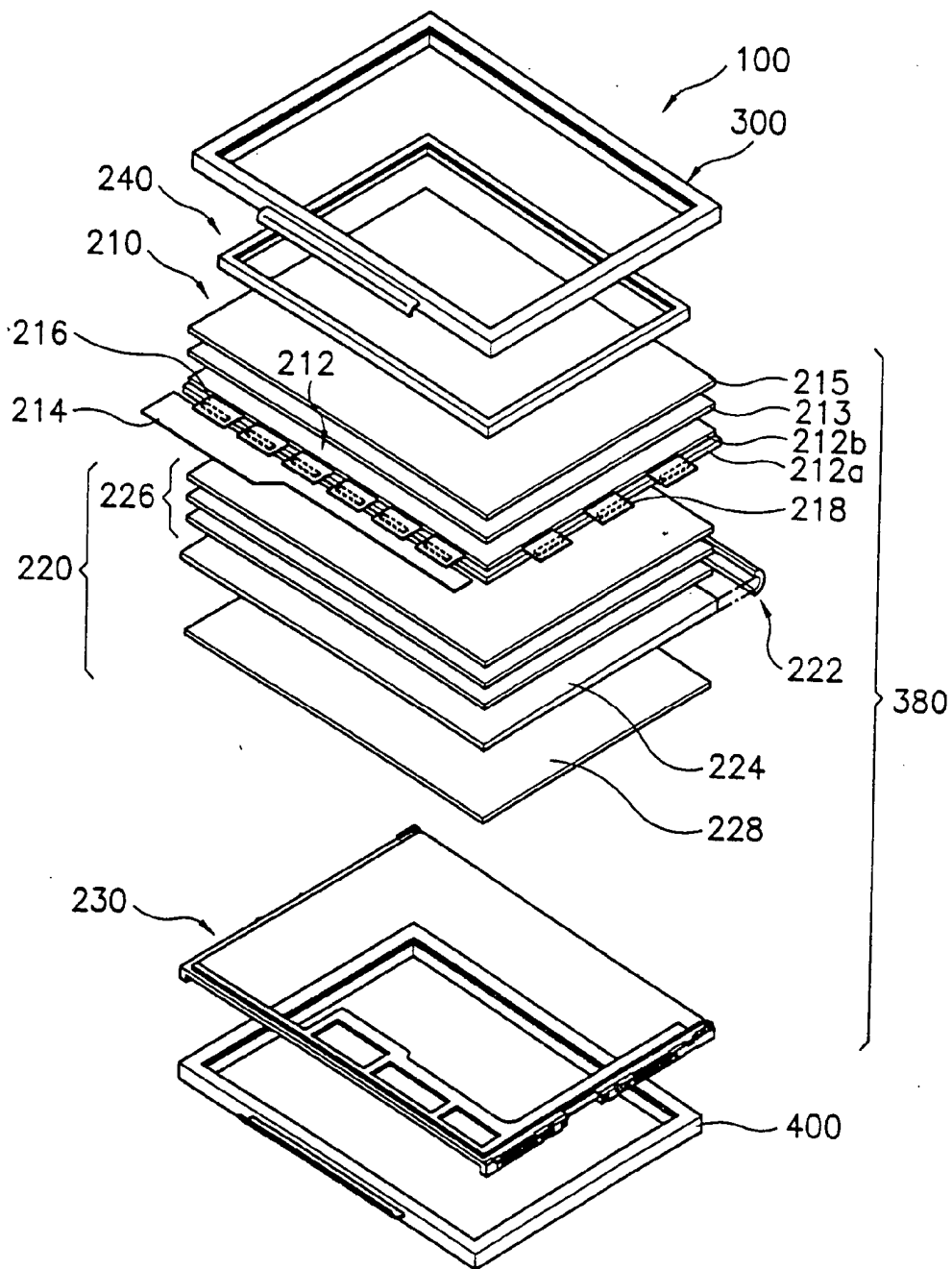

FIG. 2
(PRIOR ART)

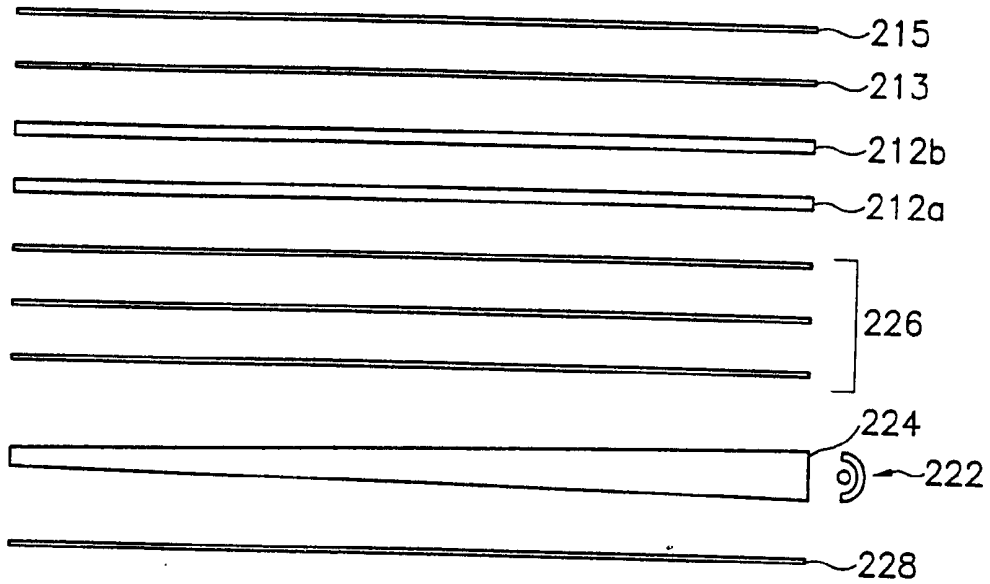

FIG. 3

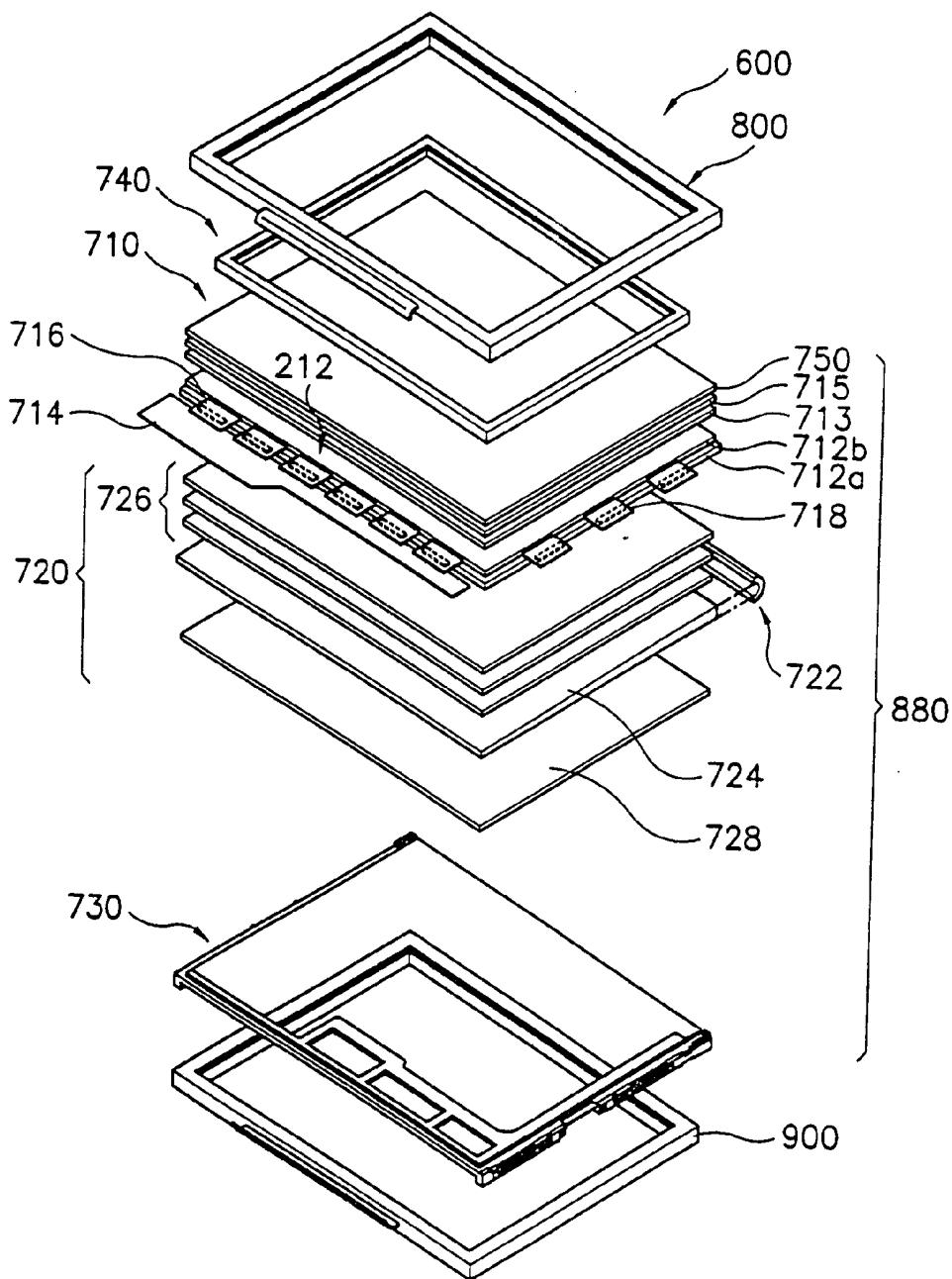

FIG. 4

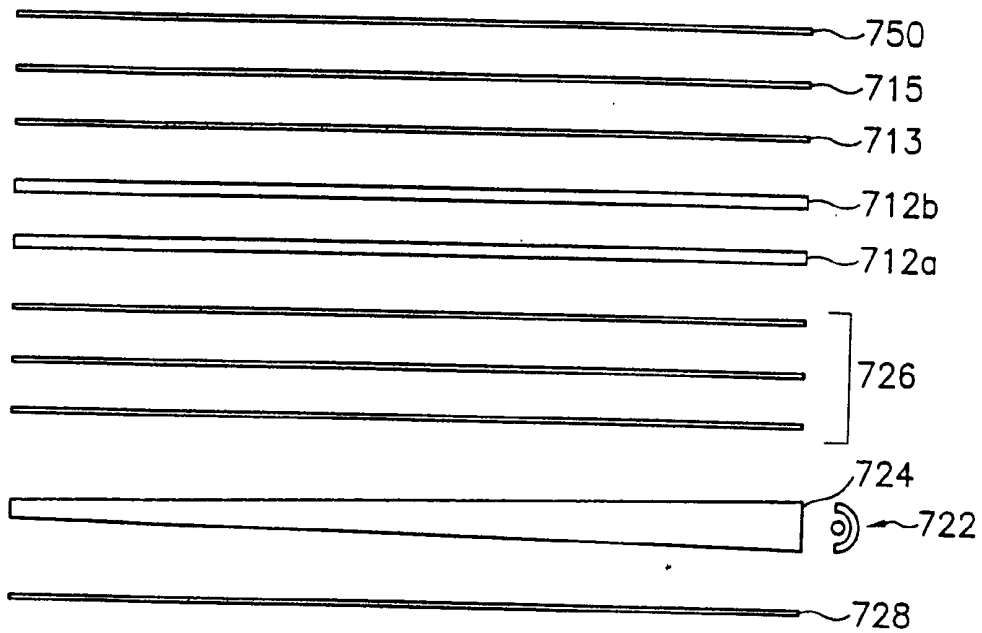

FIG. 5A

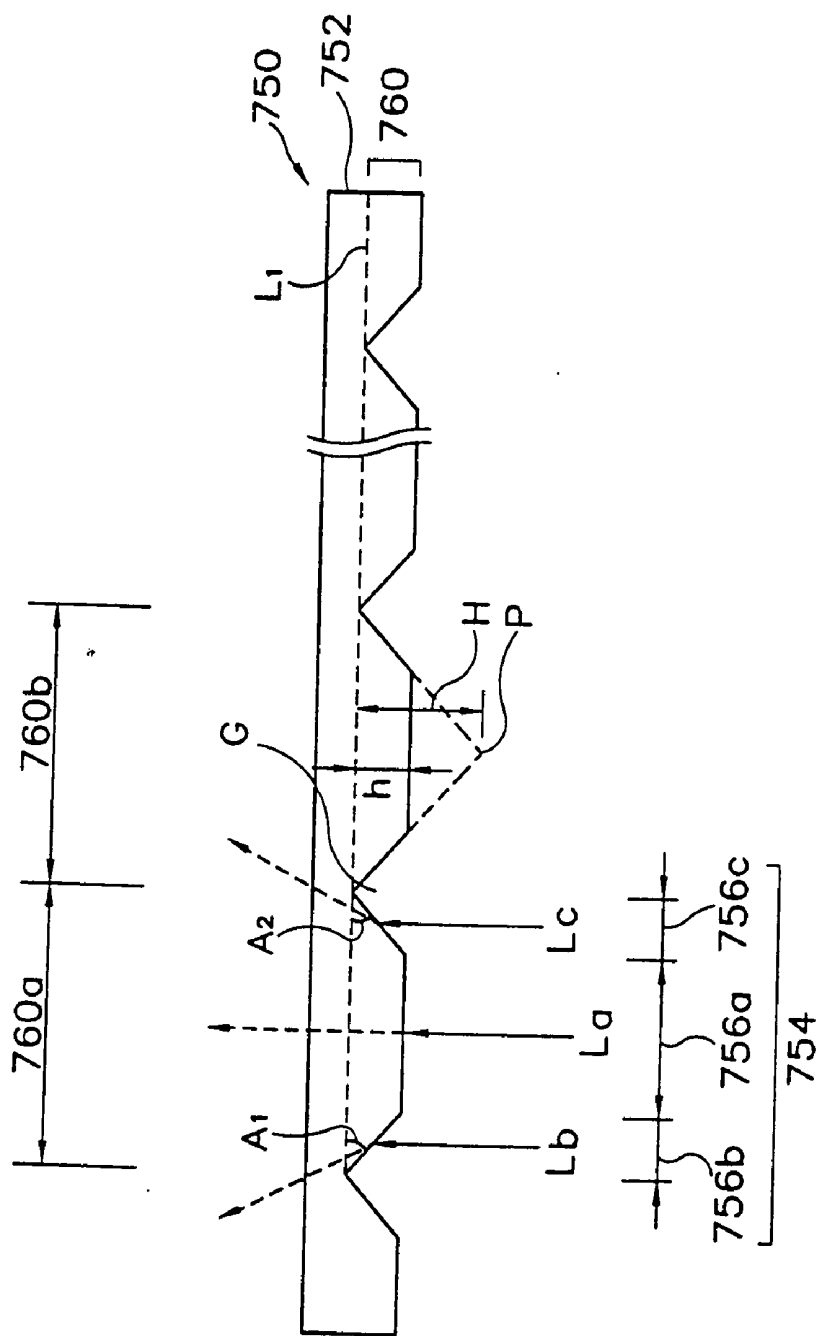

FIG. 5B

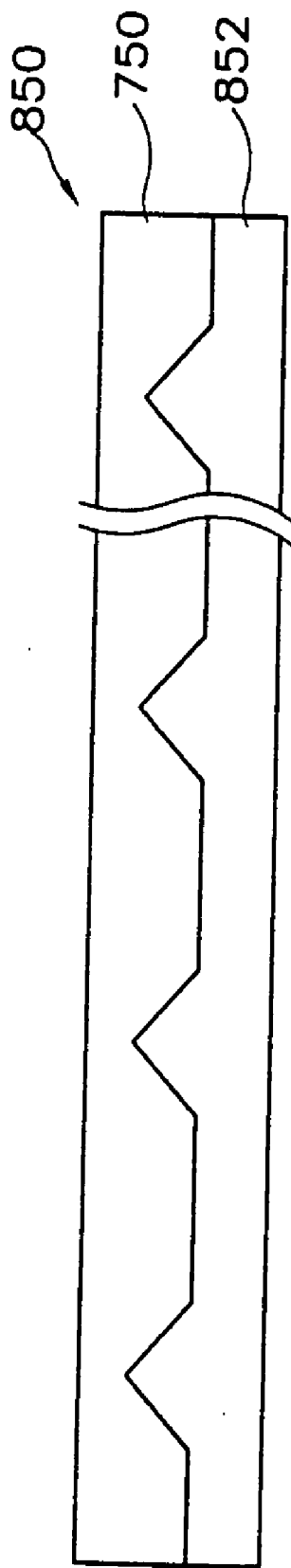

FIG. 6A

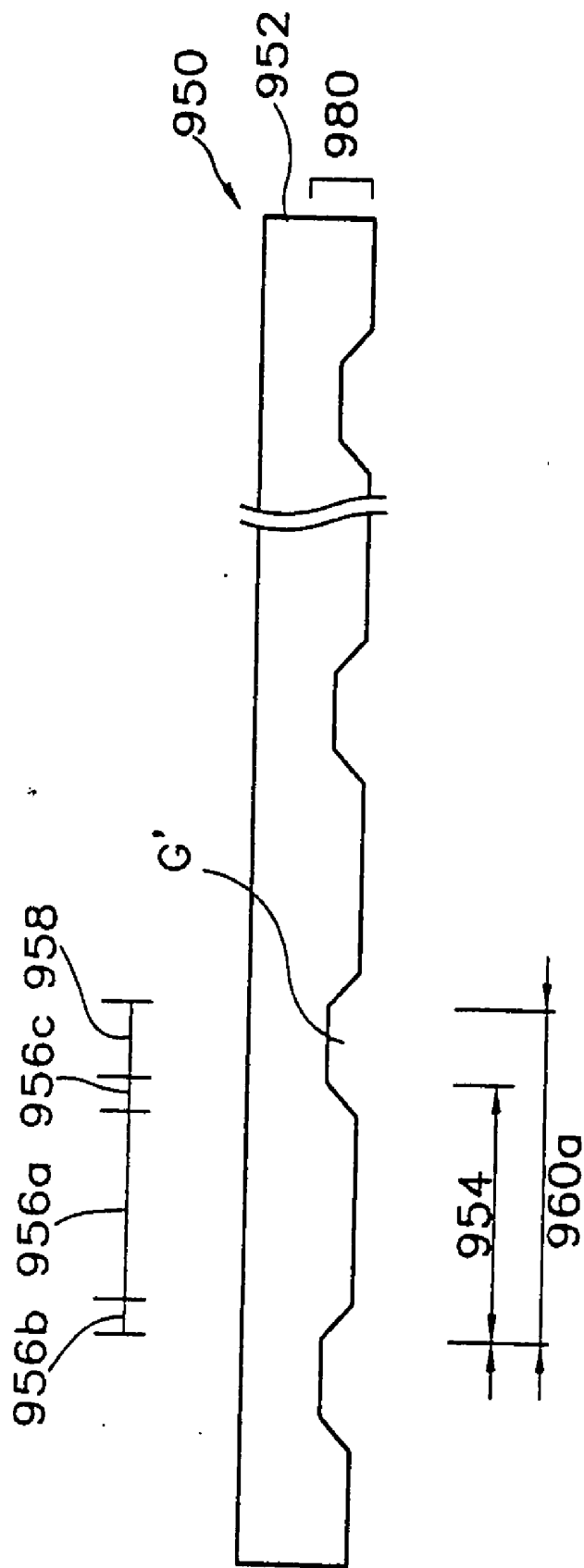

FIG. 6B

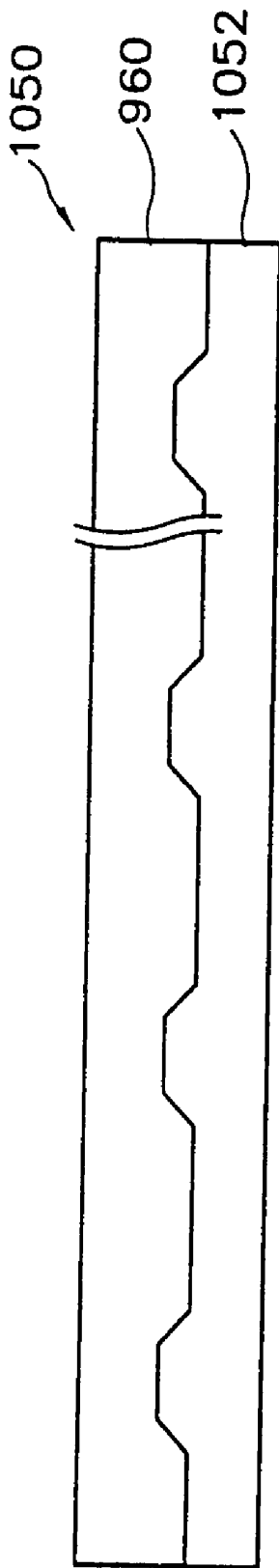

FIG. 7A

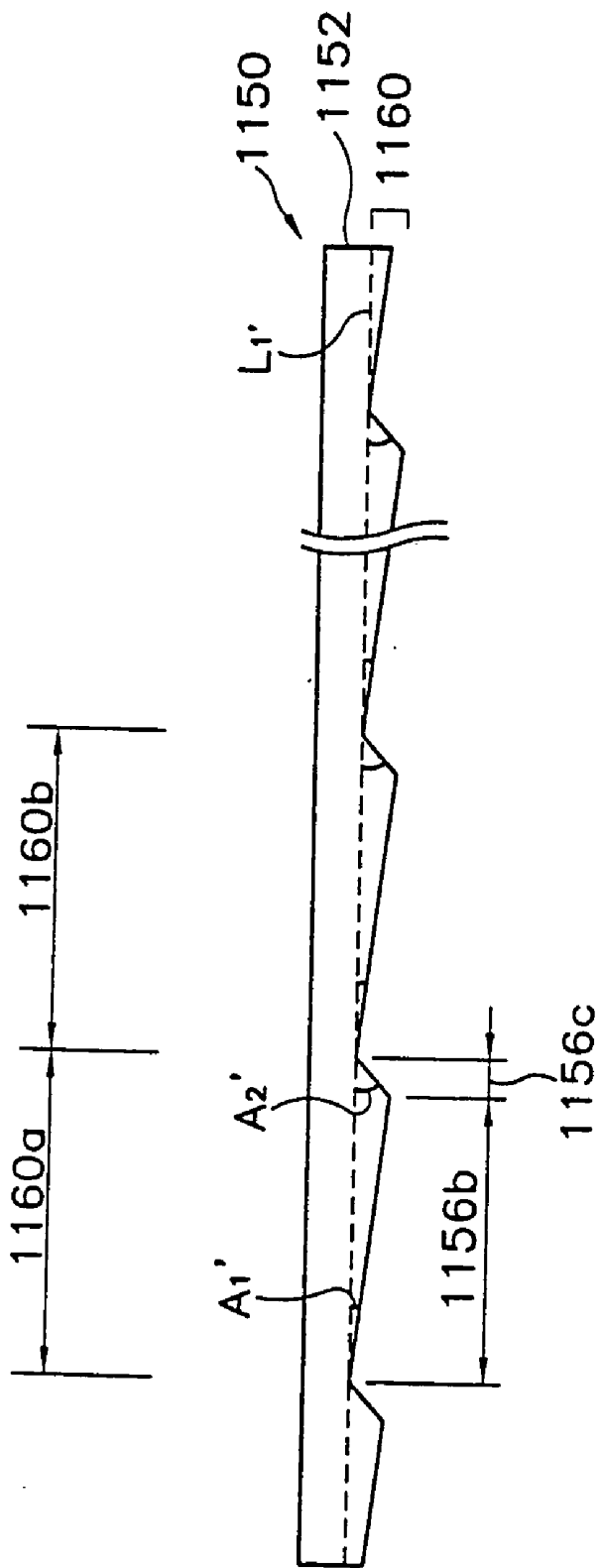

FIG. 7B

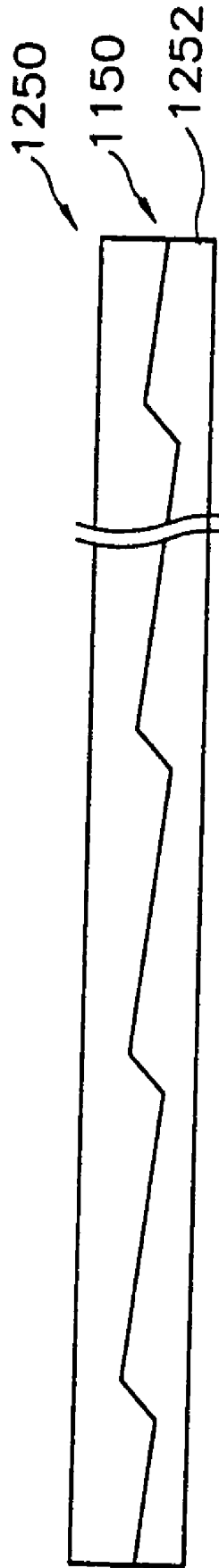

FIG. 8A

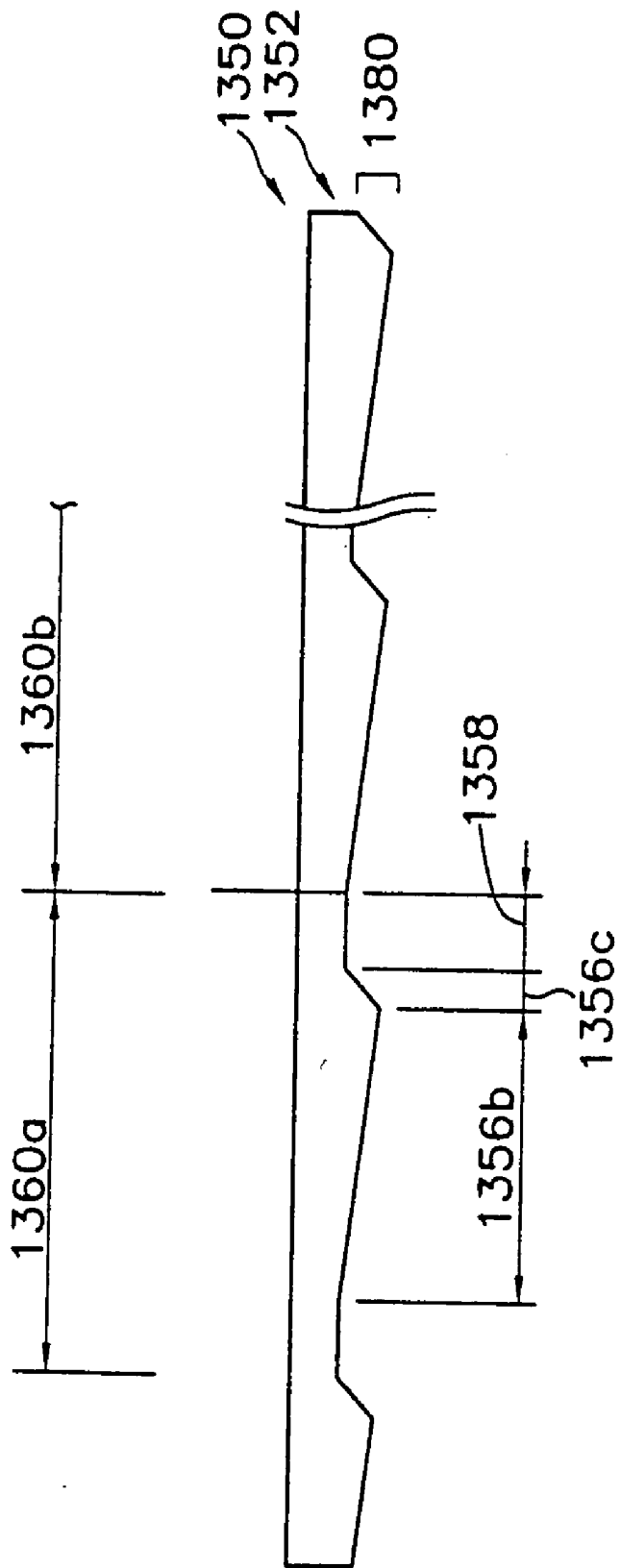

FIG. 8B

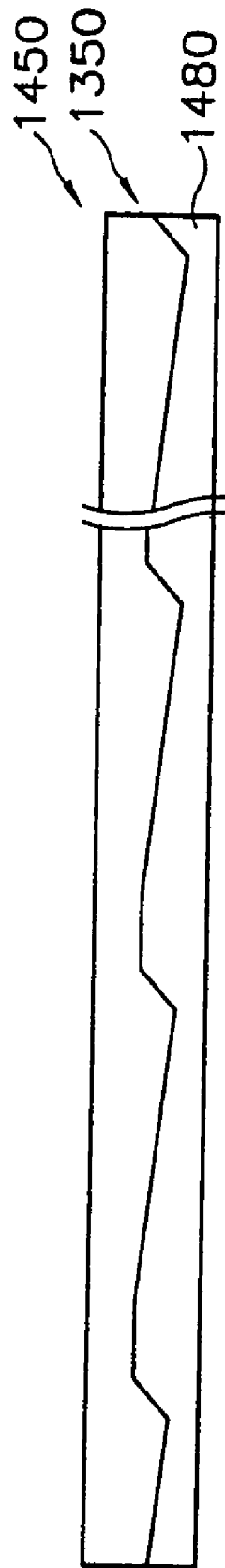

FIG. 9

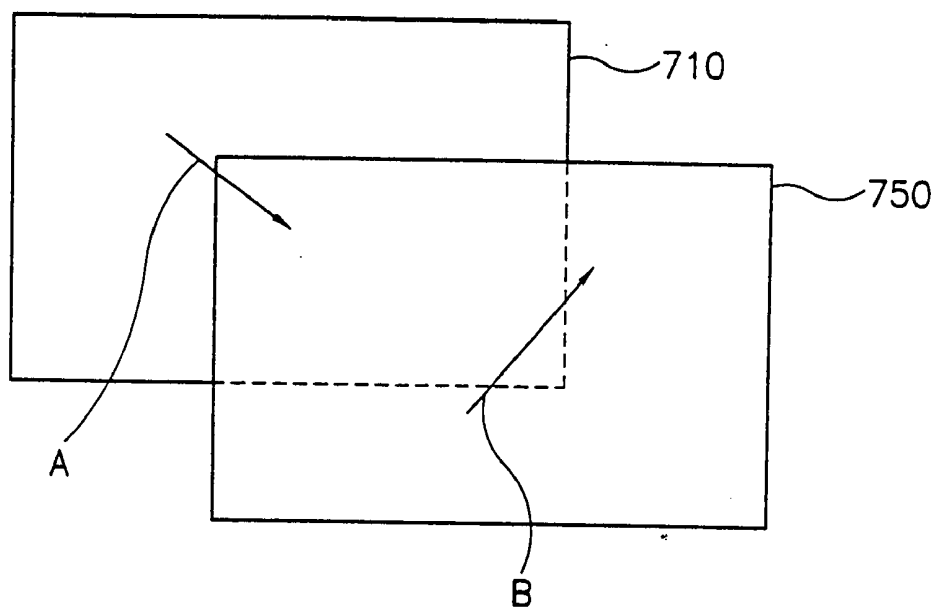

FIG. 10A

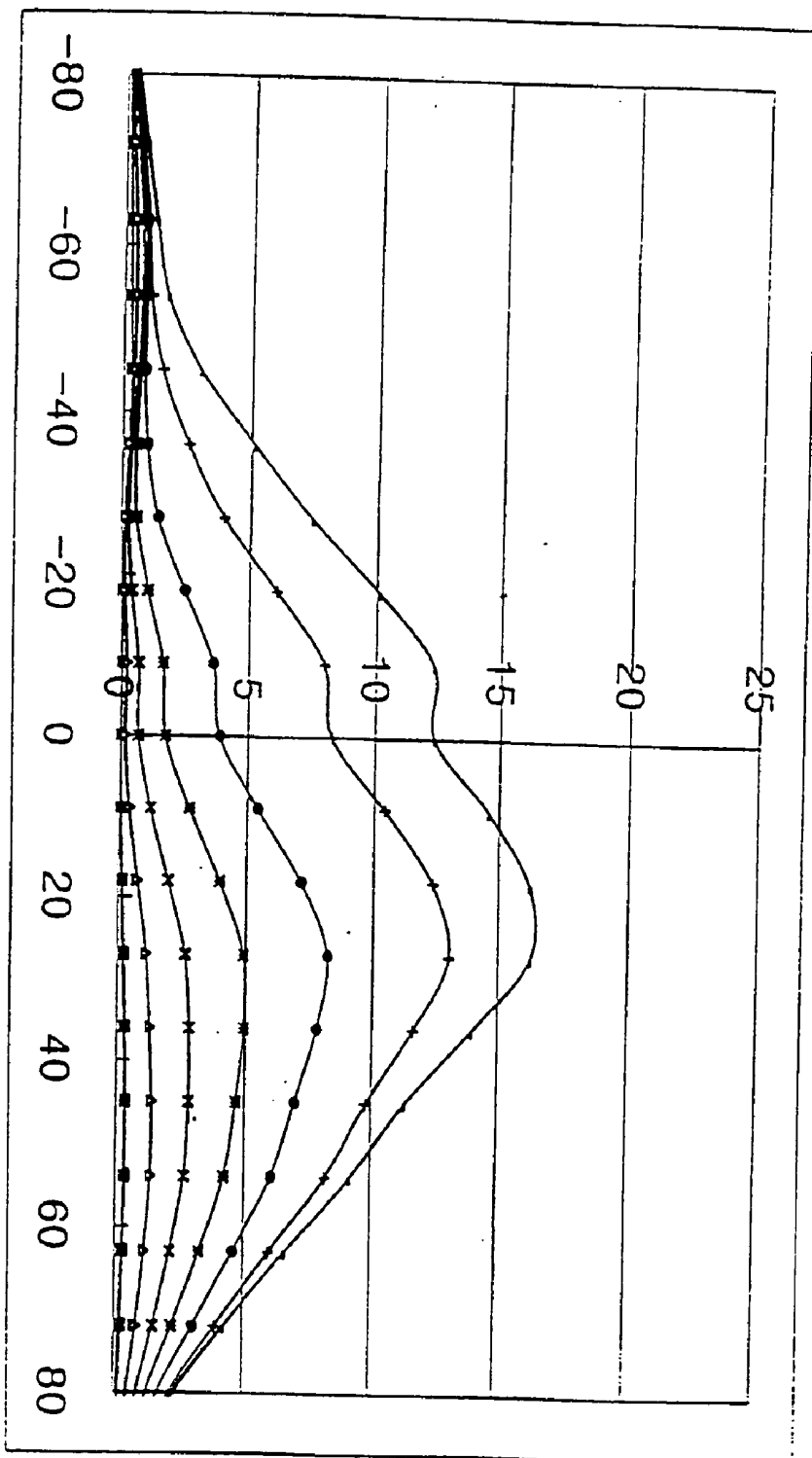

FIG. 10B

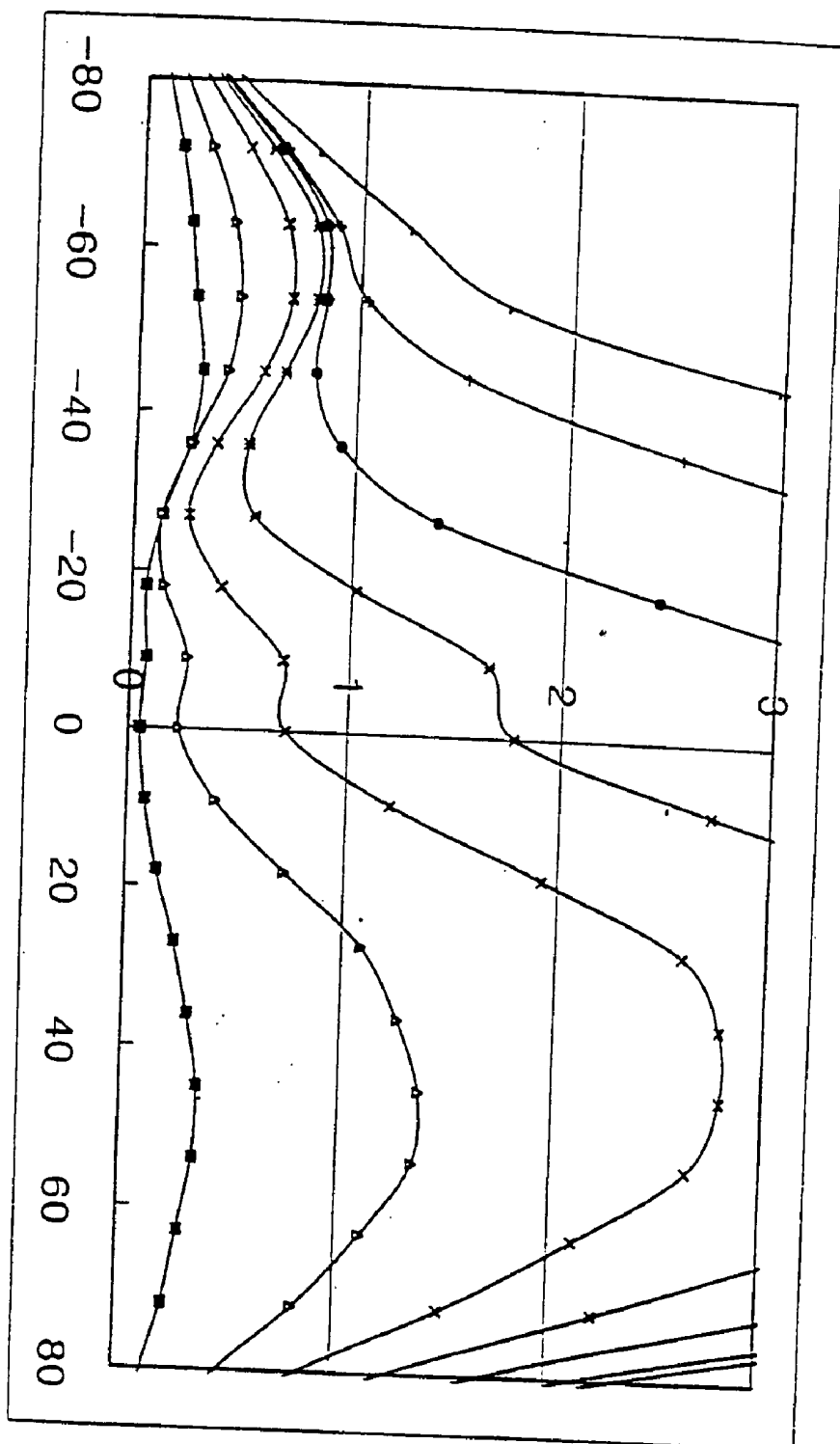

FIG. 10C

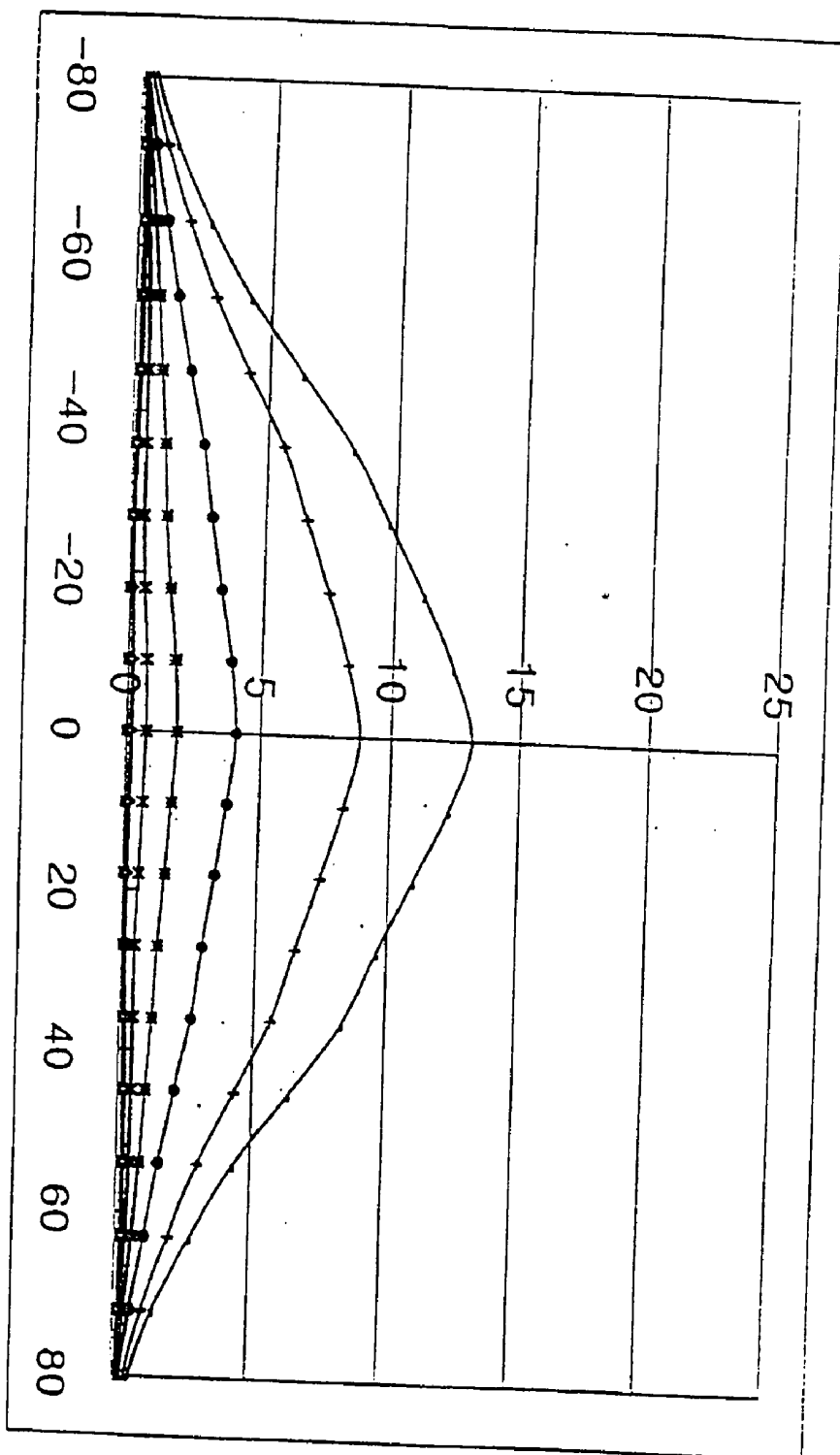

FIG. 11A

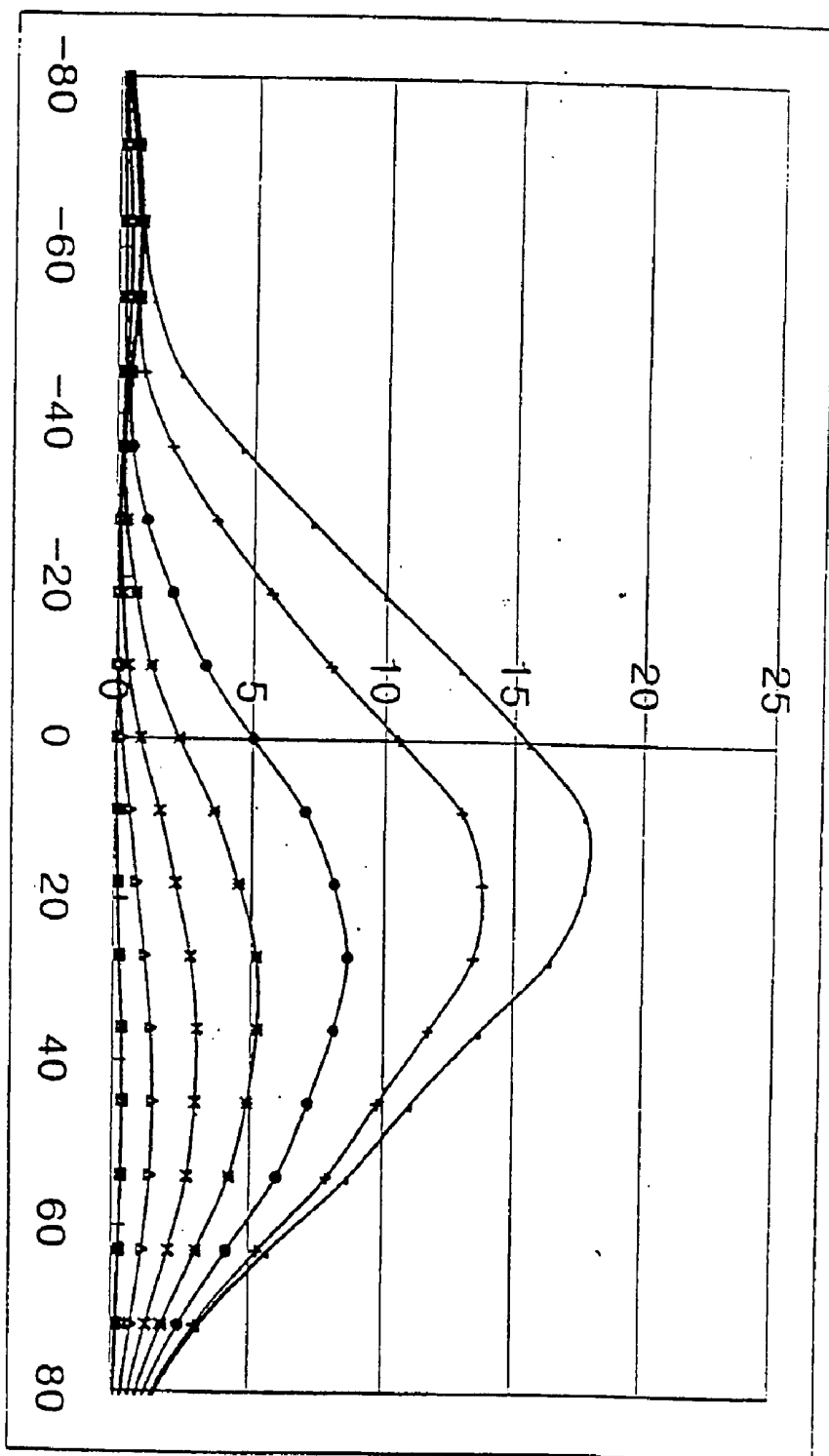

FIG. 11B

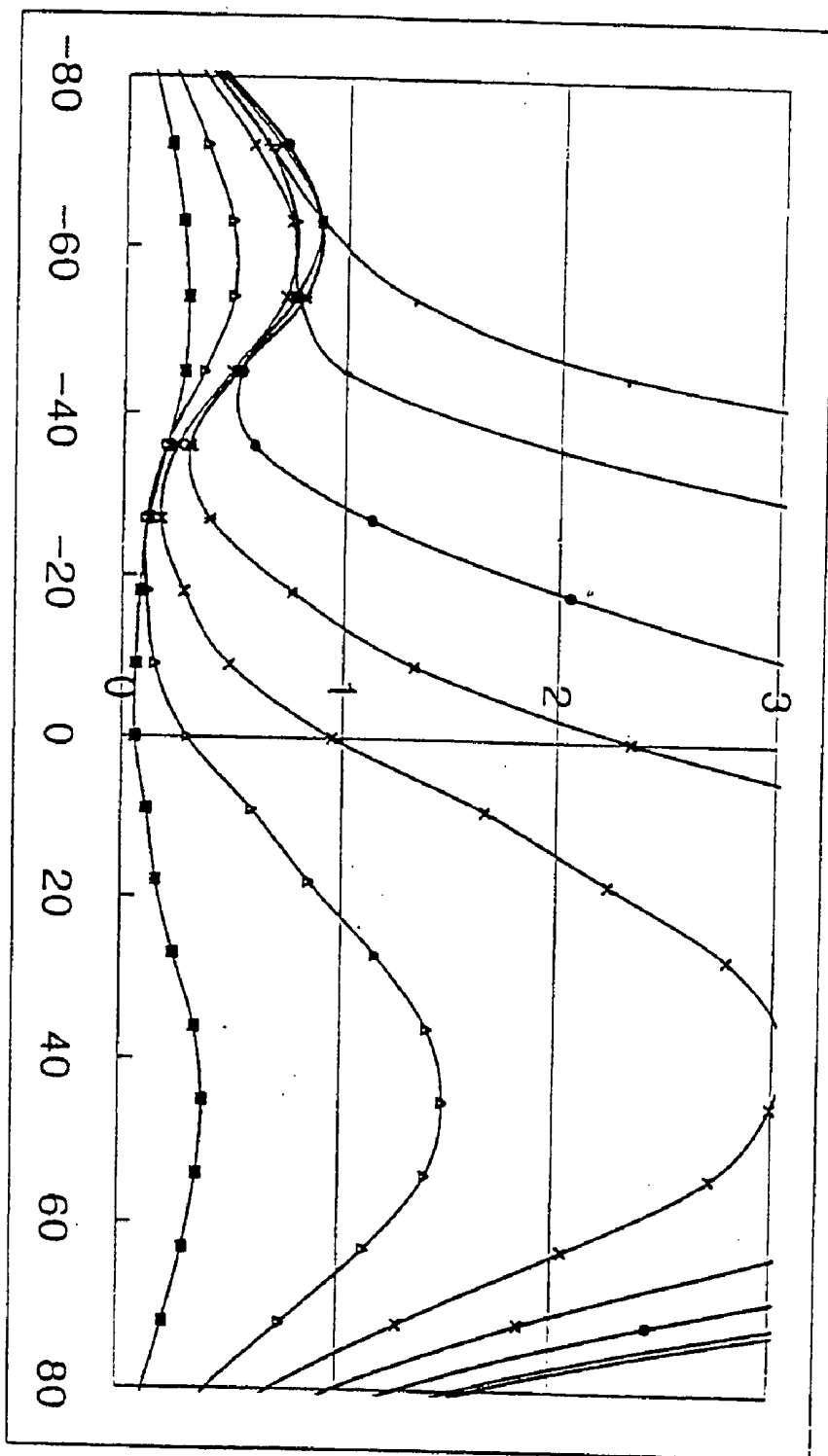

FIG. 11C

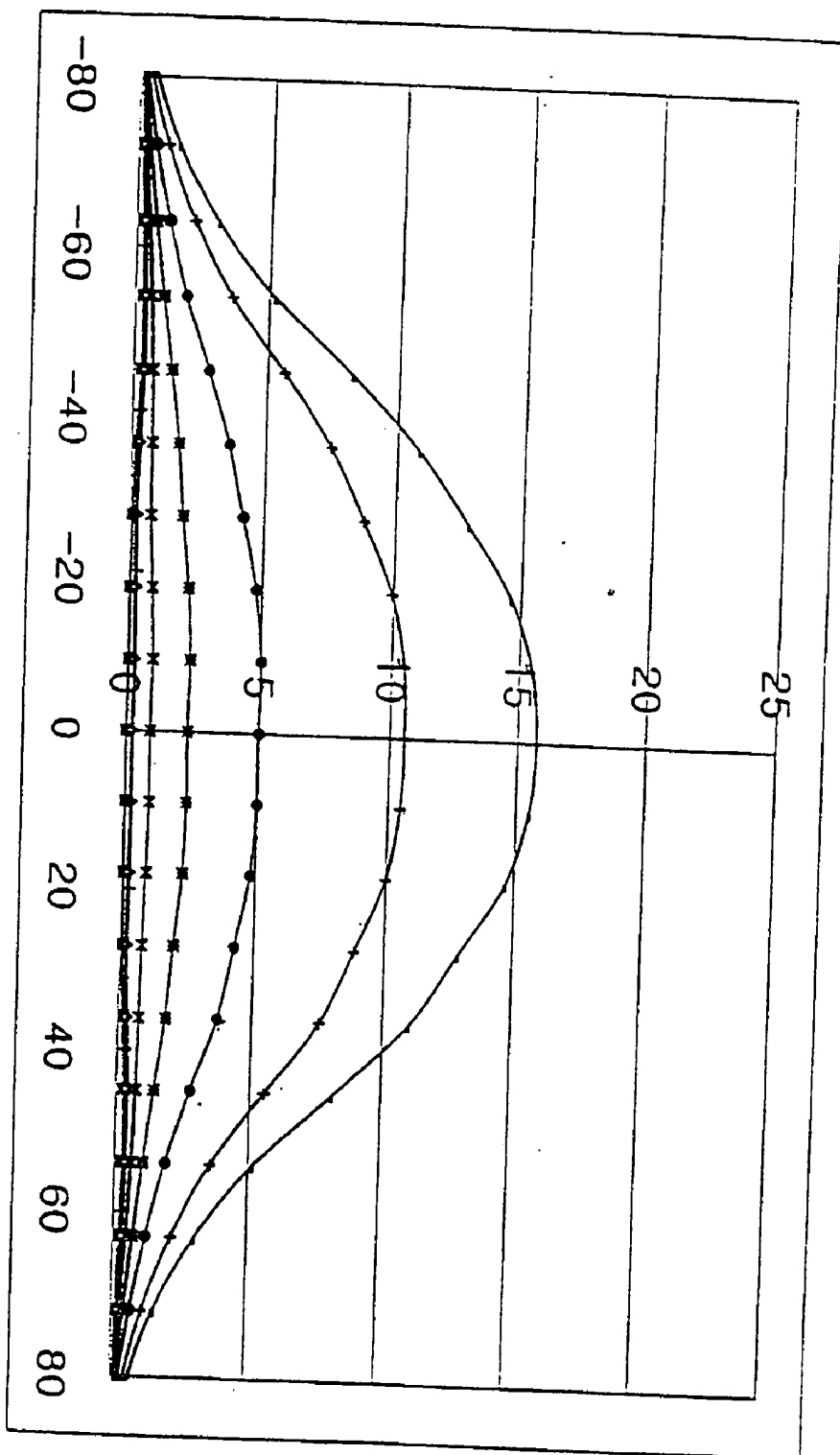

FIG. 12A

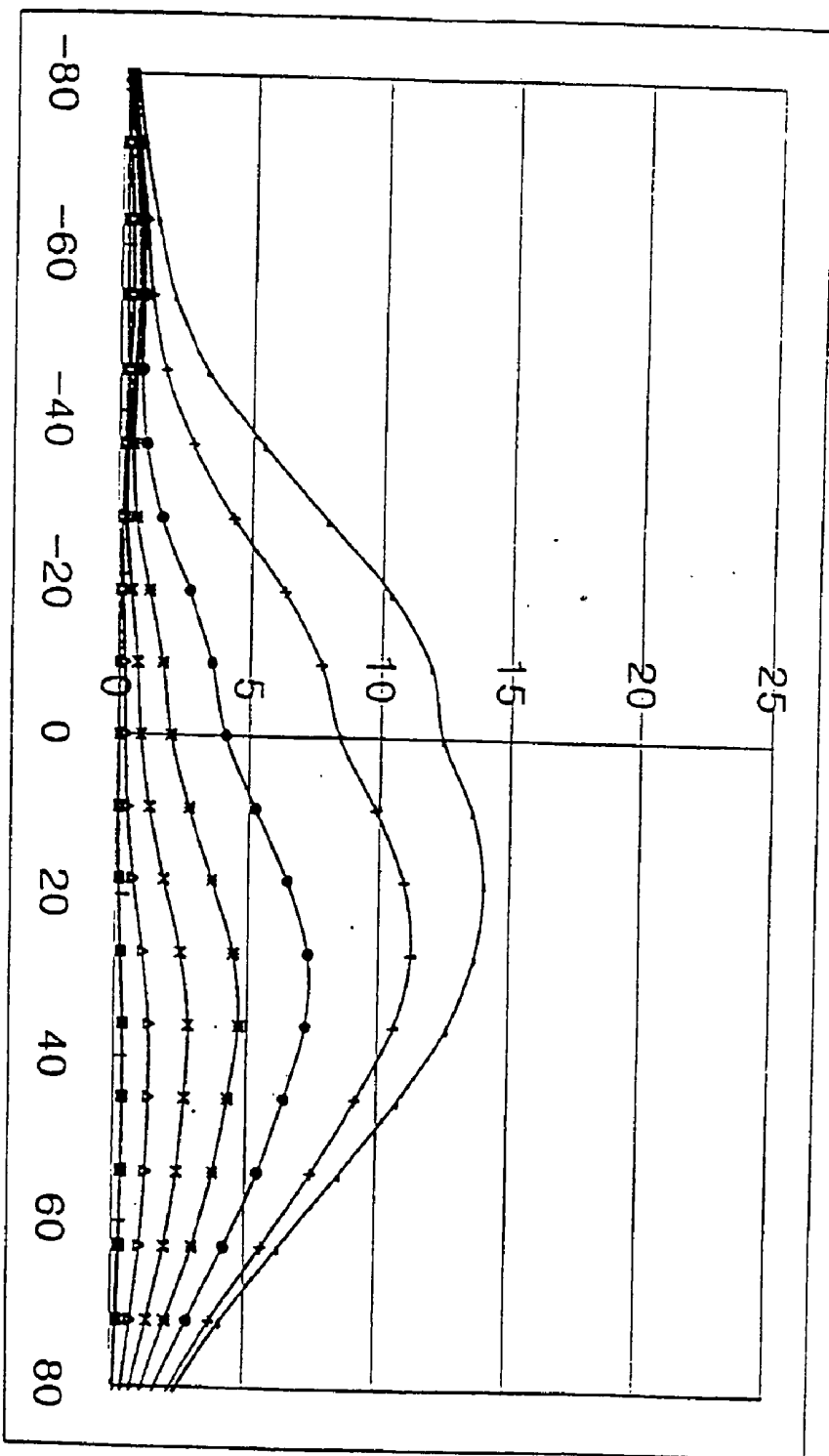

FIG. 12B

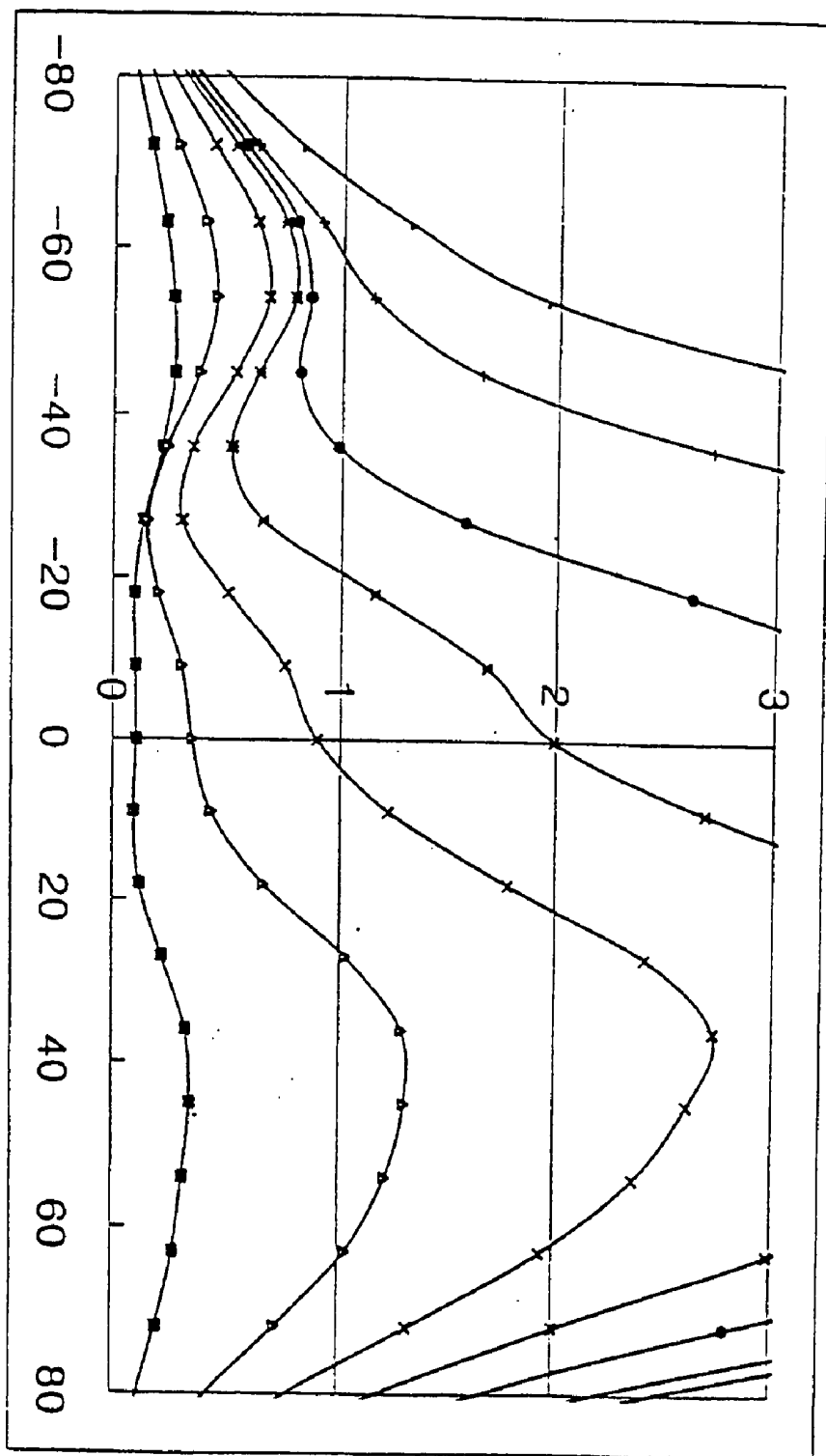

FIG. 12C

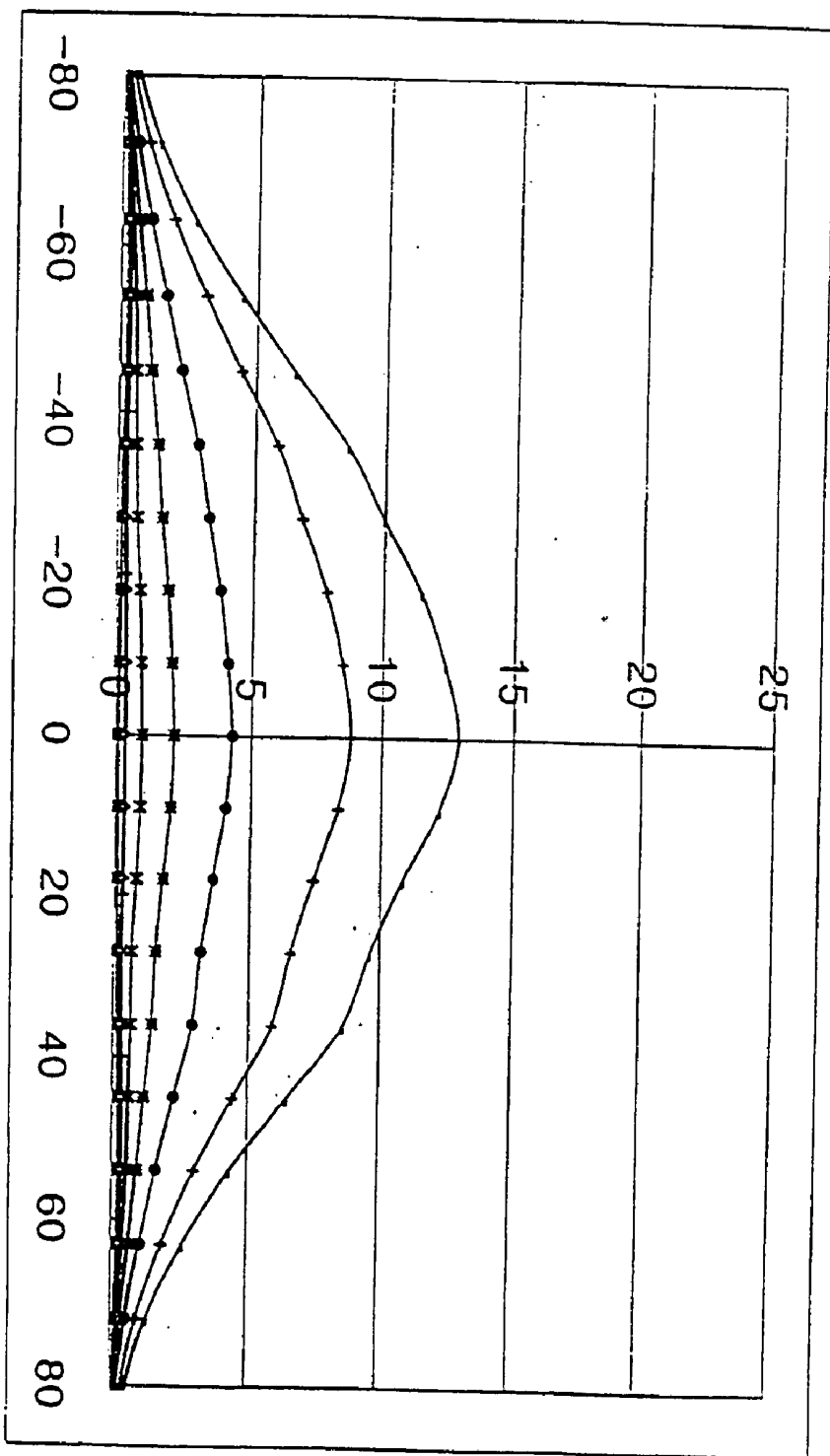

FIG. 13A

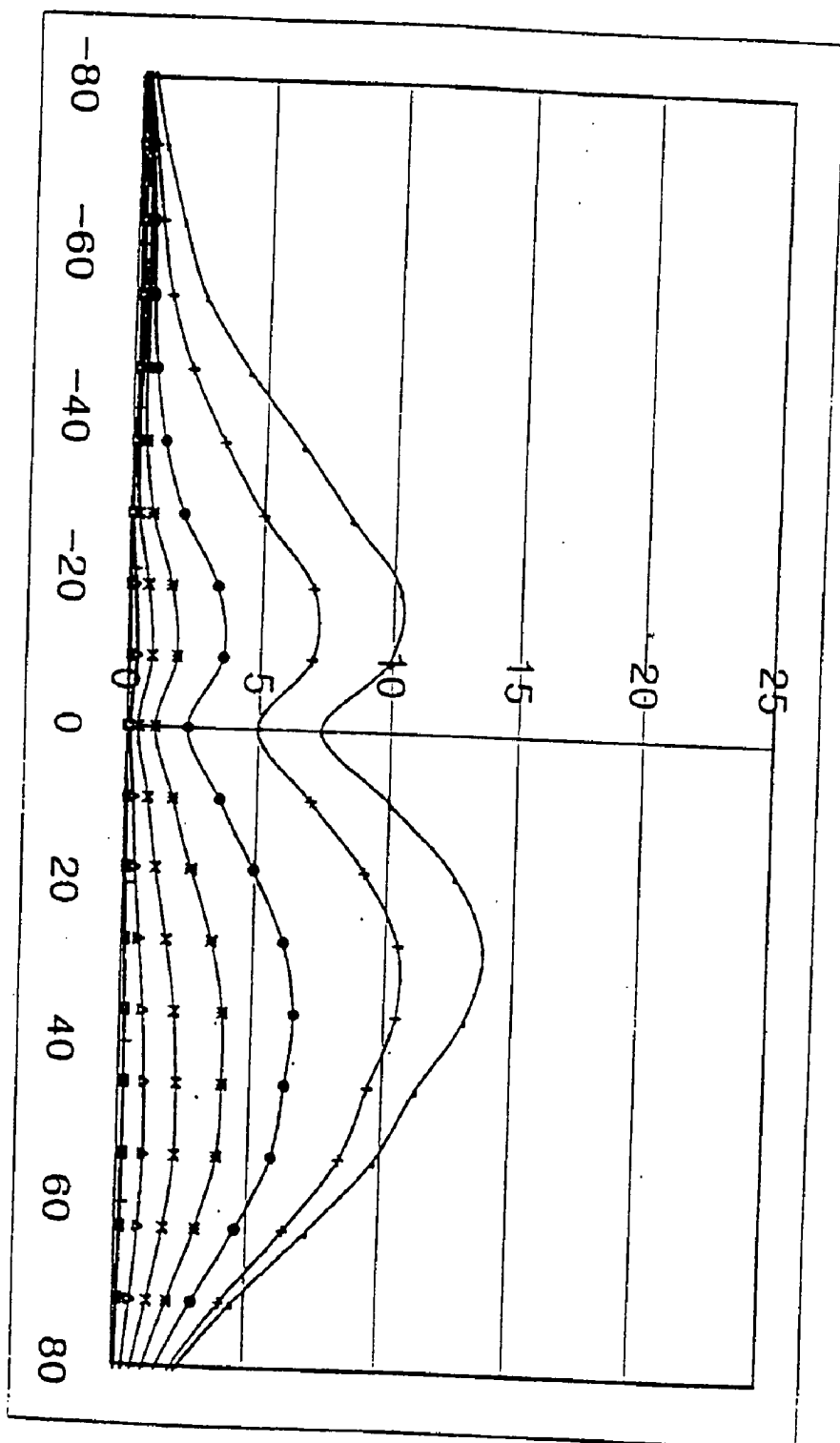

FIG. 13B

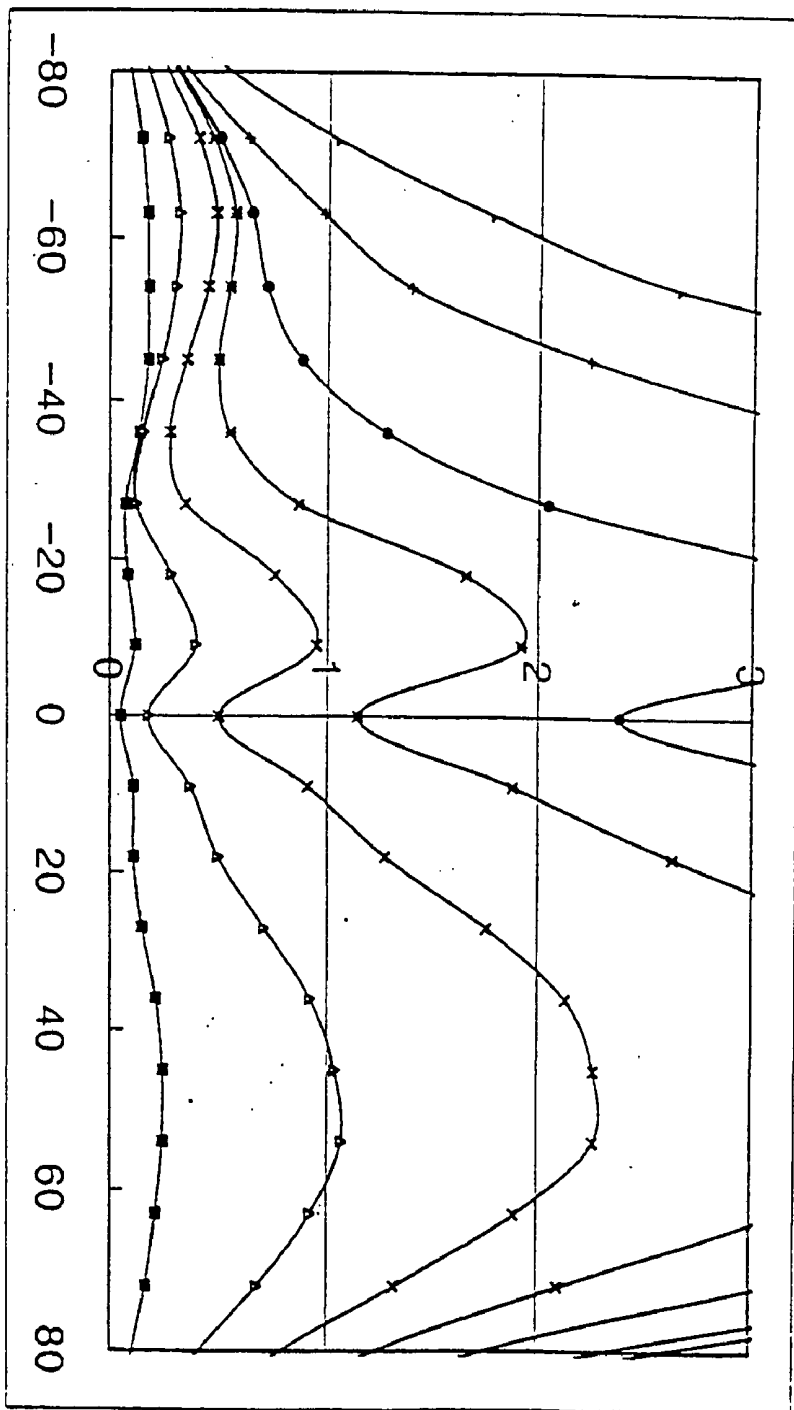

FIG. 13C

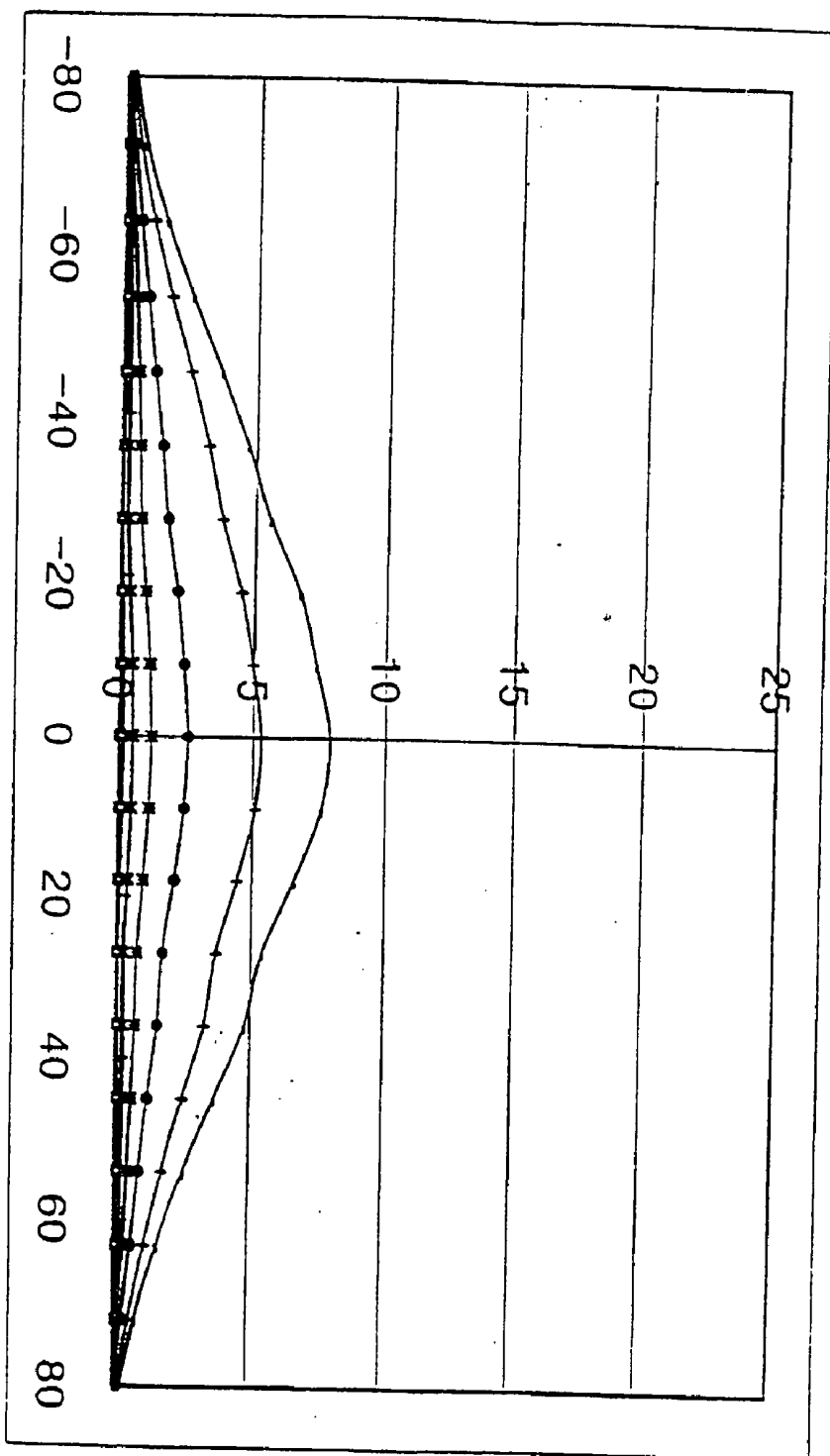

FIG. 14A

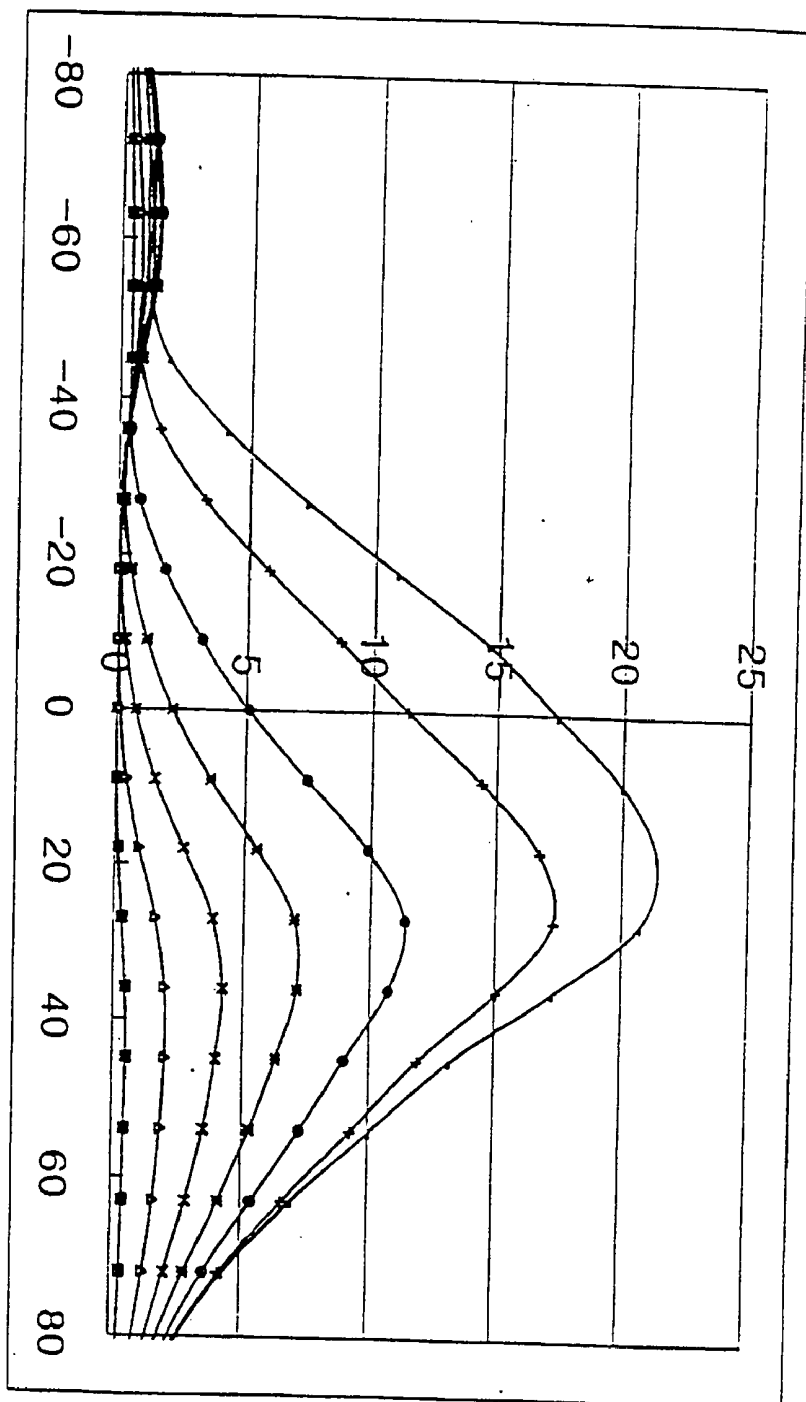

FIG. 14B

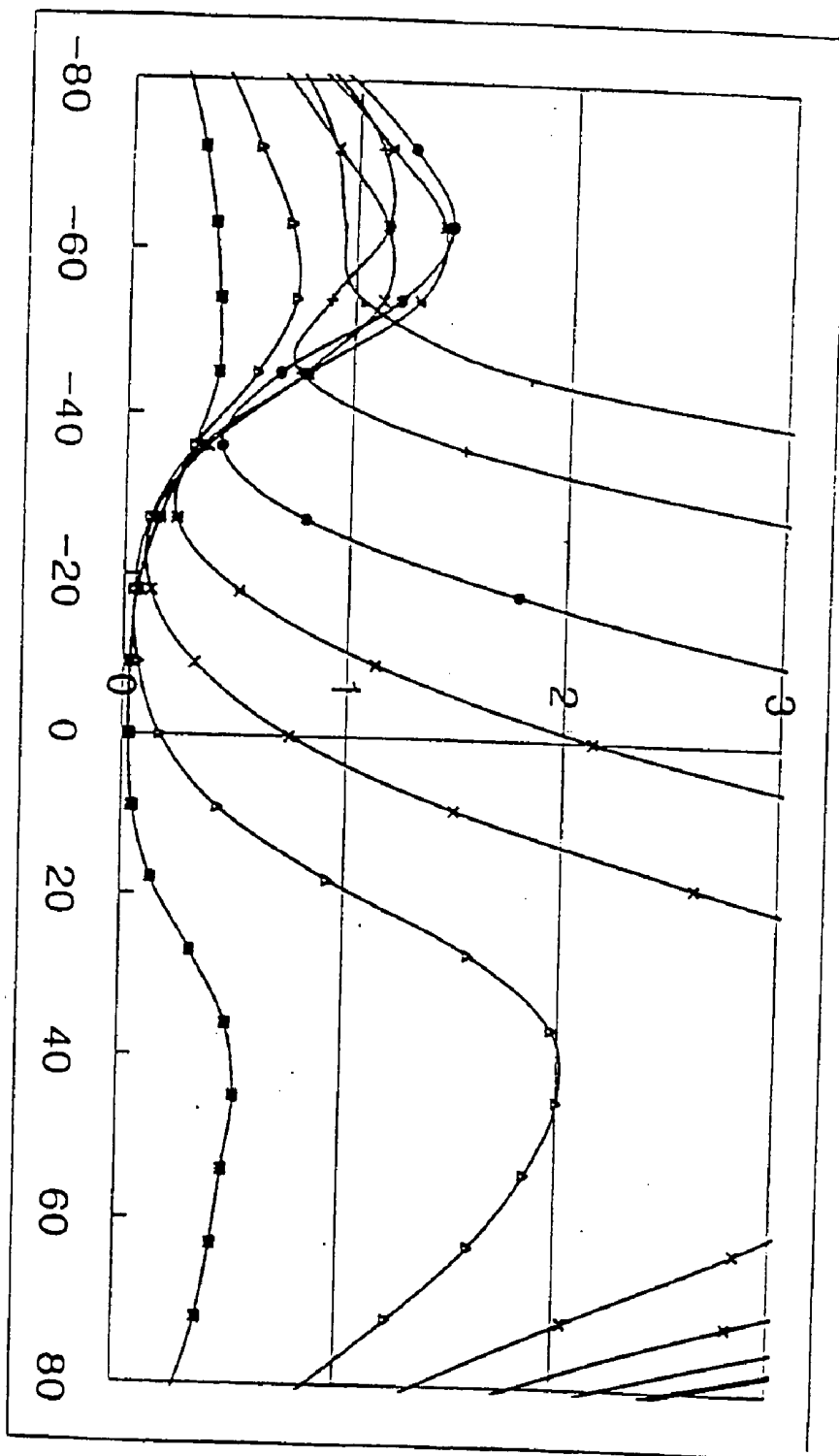

FIG. 14C

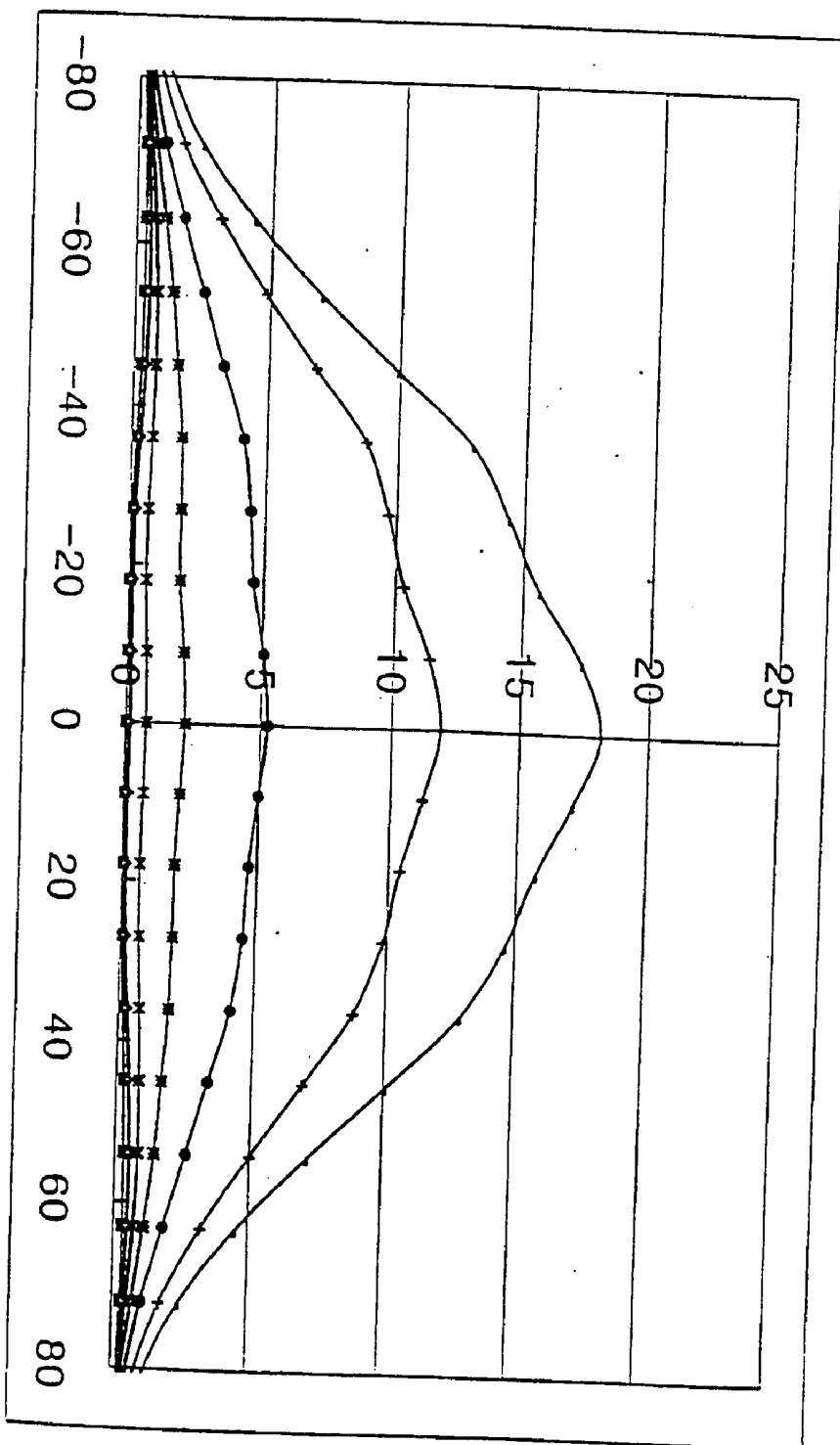

FIG. 15A

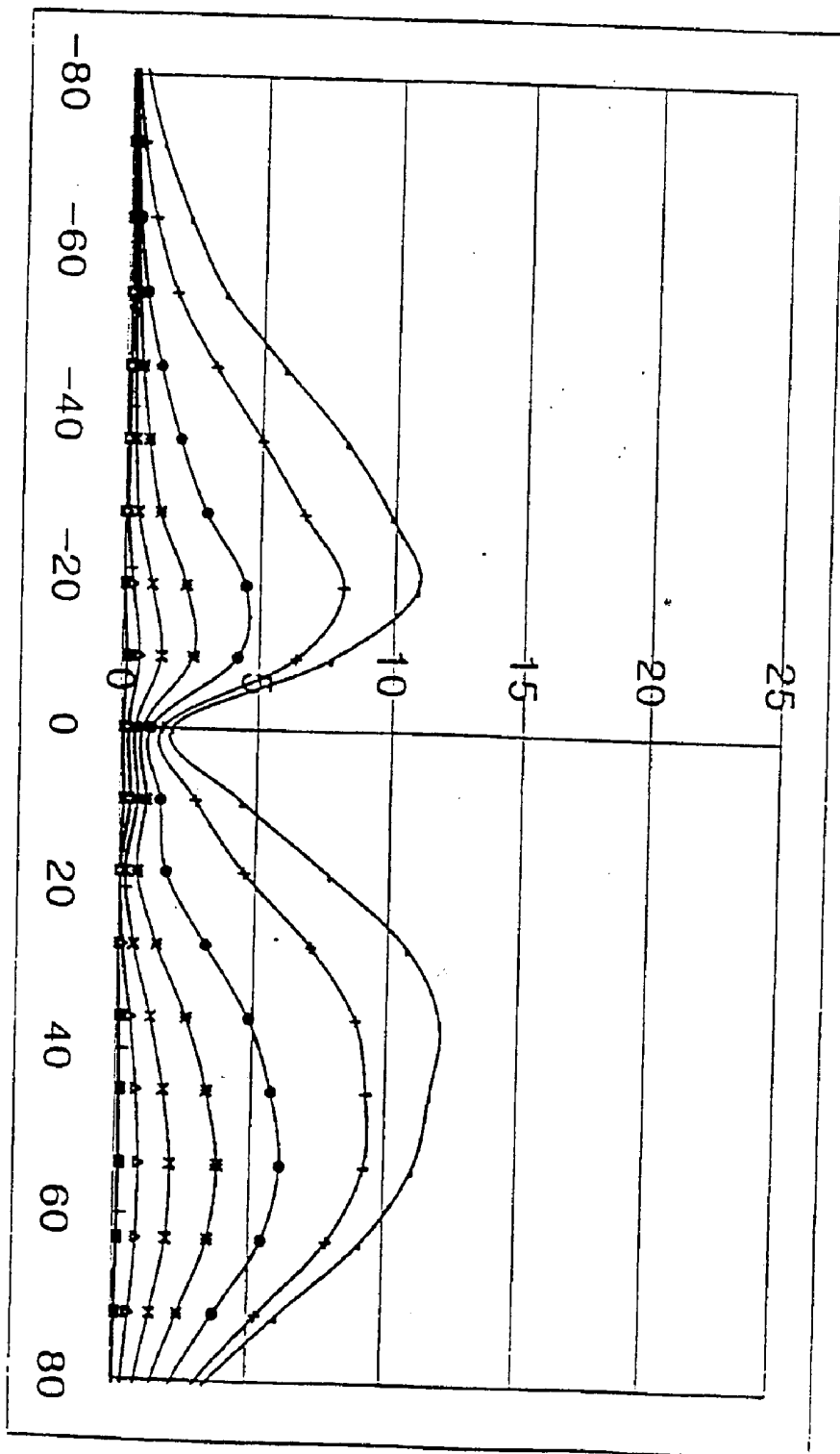

FIG. 15B

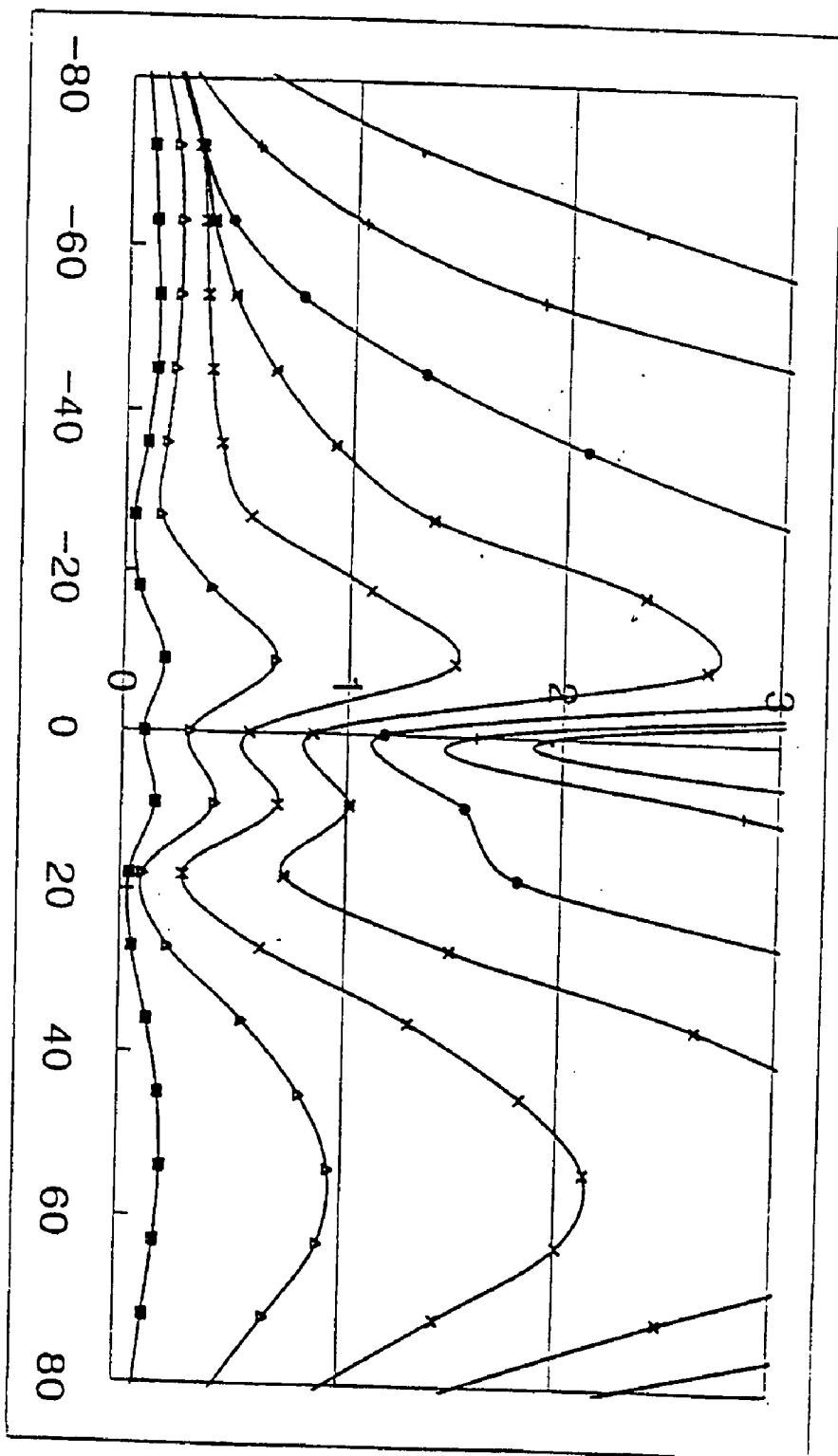
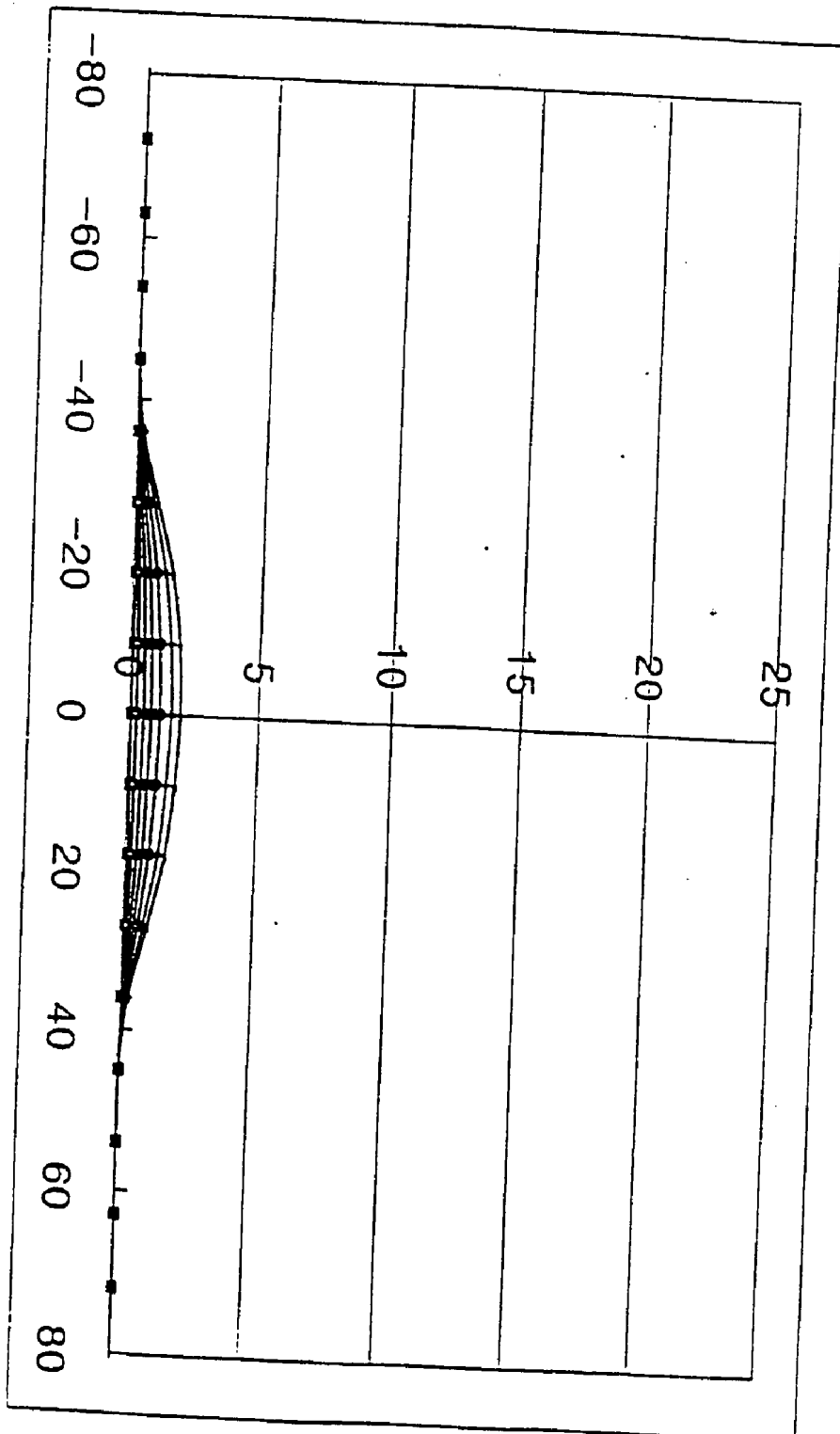

FIG. 15C



LIQUID CRYSTAL DISPLAY DEVICE

BACKGROUND OF THE INVENTION

[0001] 1. Field of the Invention

[0002] The present invention relates to a liquid crystal display device. More particularly, the present invention relates to a liquid crystal display device having a visual field angle while being capable of restraining or relaxing a gray scale inversion.

[0003] 2. Description of the Related Art

[0004] Generally, the liquid crystal display device applies voltage to the liquid crystal in predetermined molecule arrays to change the liquid crystal in the other arrays, of which the liquid crystal cells undergoes a change of optical characteristics such as a double refractivity, a rotatory polarization, a dichroism and a light scattering according to the molecule arrays of the liquid crystal to emit the light. Therefore, the liquid crystal display device can display the images according to the changes of the optical characteristics of the liquid crystal cell.

[0005] The liquid crystal display device is typically divided into a twisted nematic type of the liquid crystal display device and a super twisted nematic type of the liquid crystal display device. According to an operation way, further, the liquid crystal display device is divided into an active matrix display way of the liquid crystal display device using switching elements and twisted nematic liquid crystal and a passive matrix display way of the liquid crystal display device using super twisted nematic liquid crystal.

[0006] There is a difference of the active matrix display type of the liquid crystal display device and the passive matrix display way of the liquid crystal display device in that the liquid crystal display device in the active matrix display way uses a thin film transistors as switches to operate liquid crystal while the liquid crystal display device in the passive matrix display way does not use transistors as it does not requires complex circuits. The liquid crystal display device using the thin film transistor is widely used as a lap top computer recently is popularized.

[0007] The liquid crystal display device comprises a liquid crystal display panel having liquid crystal to decide whether to transmit light as receiving electric signals. The liquid crystal display panel is a passive element that does not generates the light by itself. Accordingly, a backlight assembly is attached to a surface of the liquid Crystal display panel in order to provide the light to the liquid crystal display device. Furthermore, the liquid crystal display panel has a source portion for applying image data to display images and a gate portion for applying gate signals to operate a gate element of the thin film transistor in the liquid crystal display panel, which are attached to the liquid crystal display panel. The liquid crystal in the liquid crystal display panel receives the electric signals when image signals are applied through the source portion and the gate portion to the transistor of the liquid crystal display panel. Thereby, the liquid crystal controls the light from the backlight assembly to make the images.

[0008] FIG. 1 is an exploded perspective view of showing a liquid crystal display device according to the conventional art and FIG. 2 is a sectional view of showing a liquid crystal

display module of the liquid crystal display device in an-assembled state, shown in FIG. 1.

[0009] Referring to FIGS. 1 and 2, the liquid crystal display device 100 comprises a liquid crystal display module 200 for displaying images when image signals are applied thereto and front and rear cases 300 and 400 for receiving the liquid crystal display module.

[0010] The liquid crystal display module 200 includes a display unit 210 having a liquid crystal display panel for showing the images.

[0011] The display unit 210 includes a liquid crystal display panel 212, an integrated and printed circuit board 214, a tape carrier package 216 for date and a ductile printed circuit board 218 for gate. The liquid crystal display panel 212 includes a thin film transistor board 212a, a color filter board 212b and liquid crystal (not shown).

[0012] The thin film transistor board 212a is a transparent glass on which the thin film transistors are formed in matrix. Data lines are respectively connected with source terminals of the thin film transistors and gate lines connected with gate terminals of the thin film transistors. Furthermore, pixel electrodes are respectively formed at drain terminals of the thin film transistors, which are made of a transparent conductive material such as Indium Tin Oxide.

[0013] As being inputted to the data lines and the gate lines, the electric signals are applied to the source terminals and the gate terminals of each thin film transistor of the thin film transistor board 212a to turn on or turn off the thin film transistors according to an input of electricity, resulting in outputting the electric signals required to form pixels to the drain terminals.

[0014] The color filter board 212b is disposed to face to the thin film transistor board 212a in the display unit 210. RGB pixels are formed on the color film board 173 by means of a thin film process, which present a predetermined color while the light passes through the color film board 212b. Common electrodes made of Indium Tin Oxide are coated on the front surface of the color film board 212b.

[0015] The color filter board 212b has a compensatory film 213 and a polarizing plate 215 formed on an upper portion to improve a visual field angle.

[0016] When the thin film transistors of the thin film transistor board 212a are turned on by applying electricity to the gate terminals and the source terminals of the thin film transistors, electric field is created between the pixel electrodes of the thin film transistor board 212a and the common electrodes of the color filter board 212b. The electric field makes the liquid crystal, which is injected in a space between the thin film transistor board 212a and the color filter board 212b, to change the array angle thereof, resulting in that the permeability of the light is changed. As a result, it is possible to gain the desired pixels.

[0017] Meanwhile, a driving signal and a timing signal are applied to the gate lines and data lines of the thin film transistor in order to control the array angle of the liquid crystal and the time of arraying the liquid crystal in the liquid crystal display panel 212. As shown in FIG. 1, the data tape carrier package 216 is attached to the source portion of the liquid crystal display panel 212 to decide a time of applying a data driving signal. On the other hand, the

gate tape carrier package **218** is attached to the gate portion of the liquid crystal display panel **212** to decide a time of applying a gate driving signal.

[0018] The integrated and printed circuit boards **214** which applies the driving signal to the gate line and the data line as soon as receiving image signals inputted from outside of the liquid crystal display panel **212**, comes in contact with the data tape carrier package **216**. The integrated and printed circuit board **214** receives the image signals provided from an information process device (not shown) such as a computer and the like and generates the gate driving signal and the data signal for operating the liquid crystal display device and a plurality of timing signals for applying the gate driving signal and the data signal to the gate lines and the data lines of the liquid crystal display panel **212**.

[0019] The backlight assembly **220** is disposed under the display unit **210** to supply the light to the display unit **220** uniformly. The backlight assembly **220** includes a line typed lamp **222** which is disposed at an end of a liquid crystal display module **200**, for generating the light.

[0020] A light guide plate **224** has a size corresponding to that of the liquid crystal display panel **212** of the display unit **210** and has a thickness which is gradually reduced from an end adjacent to the lamp **222** to the other end being far away from the lamp **222**. The light guide plate **224** is disposed under the liquid crystal display panel **212** so as to guide the light generated by the lamp **222** to the display unit **210** while changing the pathway of the light.

[0021] A plurality of optical sheets **226** for making a brightness of the light, which is transmitted from the light guide plate **224**, to be uniform is provided on the light guide plate **224**. Further, a light reflecting plate **228** is provided under the light guide plate **224** to reflect a leaked light to the light guide plate **224** so as to improve the efficiency of the light.

[0022] The display unit **210** and the backlight assembly **220** are fixedly supported by means of a mold frame **230**. The mold frame **230** has a rectangular tetragonal shape and an opening at a top portion thereof. That is, the mold frame **230** has four sidewalls and a bottom wall on which openings are formed so that the integrated and printed circuit board **214** is bent along an outer surface of the mold frame **230** to be received through the openings in the mold frame **230**.

[0023] A chassis **240** is provided for the mold frame **230** in order to fix the integrated and printed circuit board **214** and the gate tape carrier package **218** of the display unit **210** to the bottom wall of the mold frame **230** while to bend the integrated and printed circuit board **214** and the gate tape carrier package **218** toward the outside of the mold frame **230**.

[0024] The chassis **240** has a rectangular tetragonal shape similar to the mold frame **230**, of which an upper surface is opened to expose the liquid crystal display panel **212** and sidewalls are inwardly bent to cover a peripheral surface of the liquid crystal display panel **212**.

[0025] To assemble the liquid crystal display device, firstly, the backlight assembly **220** is received in the mold frame **230**, on which in turn the display unit **210** is disposed. Next, the integrated and printed circuit board **214** connected through the data tape carrier package **216** to the display unit

210 is mounted in the openings formed in the bottom wall of the mold frame **230** while being bent along the outer surface of the sidewall of the mold frame **230**. Finally, the chassis **240** is combined with the mold frame **230** so that the display unit **210** and the backlight assembly **220** are fixed to the mold frame **230**.

[0026] At that time, the ductile circuit board **218** for gate, which is attached to the gate of the display unit **210**, is fixed to the bottom wall of the mold frame **230** with enclosing the outer surfaces of the mold frame **230**. An adhesive tape or a separate fixing member is used for fixing the ductile circuit board **218** for gate to the mold frame **230** in order to prevent the ductile circuit board **218** from departing from the mold frame **230**.

[0027] The liquid crystal display device **100** according to the conventional art as described above has a compensative film **213** including a discotic layer in order to improve the visual field angle. In the case of using the compensative film **213**, it is possible to improve the visual field angle relating to the contrast ratio. However, when the voltage is increased, it is difficult to improve a gray scale inversion in that the brightness of the light is rather reduced. Furthermore, in the case of a two domain twisted nematic mode, when the compensative film is used for improving the visual field angle, the compensated domain and the non-compensated domain are simultaneously presented in the liquid crystal display panel **212**. Accordingly, there are problems in that even though it is possible to improve the visual field angle, it is impossible to improve the gray scale inversion and in that on the contrary when the gray scale inversion is improved, it is impossible to improve the visual field angle.

SUMMARY OF THE INVENTION

[0028] The present invention has been made to solve the aforementioned problems, and accordingly it is the object of the present invention to provide an apparatus for changing a pathway of light of a liquid crystal display device capable of changing a brightness of light according to a visual field angle to relax a gray scale inversion.

[0029] It is the other object of the present invention to provide a liquid crystal display device having the device for changing the pathway of the light.

[0030] In order to achieve the object of the present invention, there is provided an apparatus for changing a pathway of light according to an aspect of the present invention, in which a part of the light is substantially transmitted in the same direction as the light proceeds while the rest of the light is transmitted through a changed pathway, in order to change a brightness of the light according to a visual field angle of the display panel to restrain a gray scale inversion of the images while the light passes through the display panel to make the images on the display panel, the means being disposed on the display panel.

[0031] The object of the present invention can be achieved by means of a film sheet for use in a display device comprising a transparent base film; and a step section having inclined side portions formed on a surface of the transparent base film, wherein a part of light is substantially transmitted in the same direction as the light proceeds while the rest of the light is transmitted through a changed pathway in order to change a brightness of the light according to a visual field

angle of a display panel to restrain a gray scale inversion of the images while the light passes through the transparent base film.

[0032] In order to achieve the other object of the present invention, there is a display device according to the other aspect of the present invention, which comprises a display panel for displaying images, a backlight assembly for providing light to the display panel, and means for changing a pathway of the light partially so that a part of the light is substantially transmitted in the same direction as the light proceeds while the rest of the light is transmitted through a changed pathway, in order to change a brightness of the light according to a visual field angle of the display panel to restrain a gray scale inversion of the images while the light passes through the display panel to make the images on the display panel, the means being disposed on the display panel.

[0033] The other object of the present invention can be achieved by means of a liquid crystal display device comprising: a liquid crystal display panel for receiving light to display images, the liquid crystal display panel including a first transparent substrate, a second transparent substrate mounted to face to the first transparent substrate and liquid crystal injected between the first transparent substrate and the second transparent substrate; a backlight assembly for providing the light to the liquid crystal display panel through the first transparent substrate; and light pathway partially changing means, disposed on an outer surface of the second transparent substrate, so that a part of the light is substantially transmitted in the same direction as the light proceeds while the rest of the light is transmitted through a changed pathway, in order to improve a contrast ratio of the images displayed on the liquid crystal display panel while the light passes through the liquid crystal display panel.

[0034] According to the present invention, a part of the light passing through the liquid crystal is substantially transmitted at a center portion of a projection in the same direction as the light proceeds and the rest of the light is transmitted through a changed pathway at a peripheral portion of the projection. The rest of the light having the changed pathway makes the visual field angle of the liquid crystal display panel to be ensured, while relaxing the gray scale inversion along with the part of the light passing through the center portion of the projection.

BRIEF DESCRIPTION OF THE DRAWINGS

[0035] The above and other objects and advantages of the present invention will become readily apparent by reference to the following detailed description when considered in conjunction with the accompanying drawings wherein:

[0036] FIG. 1 is an exploded perspective view of showing a liquid crystal display device according to the conventional art;

[0037] FIG. 2 is a sectional view of showing a liquid crystal display module of the liquid crystal display device shown in FIG. 1 in an assembled state, schematically;

[0038] FIG. 3 is an exploded perspective view of showing a liquid crystal display device according to an embodiment of the present invention;

[0039] FIG. 4 is a sectional view of showing the liquid crystal display device shown in FIG. 3 in an assembled state, schematically;

[0040] FIGS. 5a and 5b are sectional views of showing a member for changing a pathway of light partially according to first and second embodiments of the present invention;

[0041] FIGS. 6a and 6b are sectional views of showing a member for changing a pathway of light partially according to third and fourth embodiments of the present invention;

[0042] FIGS. 7a and 7b are sectional views of showing a member for changing a pathway of light partially according to fifth and sixth embodiments of the present invention;

[0043] FIGS. 8a and 8b are sectional views of showing a member for changing a pathway of light partially according to seventh and eighth embodiments of the present invention;

[0044] FIG. 9 is a plan view of showing a planar arrangement relation between a thin film transistor board and members for changing the pathway of the light partially show in FIG. 3.

[0045] FIGS. 10a to 10c are simulated graphs of showing a variation of a brightness of light in a sample 1, according to a visual field angle;

[0046] FIGS. 11a and 11c are simulated graphs of showing a variation of a brightness of light in a sample 2, according to the visual field angle;

[0047] FIGS. 12a to 12c are simulated graphs of showing a variation of a brightness of light in a sample 3, according to the visual field angle;

[0048] FIGS. 13a to 13c are simulated graphs of showing a variation of a brightness of light in a sample 4, according to the visual field angle;

[0049] FIGS. 14a to 14c are simulated graphs of showing a variation of a brightness of light in a comparative sample 1, according to the visual field angle; and

[0050] FIGS. 15a to 15c are simulated graphs of showing a variation of a brightness of light in a comparative sample 2, according to the visual field angle.

DETAILED DESCRIPTION OF THE PREFERRED EMBODIMENT

[0051] Hereinafter, the present invention will be described in detail with reference to the accompanying drawings.

[0052] FIG. 3 is an exploded perspective view of showing a liquid crystal display device according to an embodiment of the present invention and FIG. 4 is a view of showing the liquid crystal display device in an assembled state in FIG. 3, schematically.

[0053] Referring to FIGS. 3 and 4, the liquid crystal display device 600 includes a liquid crystal display module 700 for displaying images when an image signal is applied thereto and front and rear cases 800 and 900, for receiving the liquid crystal display module 700.

[0054] The liquid crystal display module 700 has a display unit 710 including a liquid crystal display panel that shows images.

[0055] The display unit 710 comprises a liquid crystal display panel 712, an integrated and printed circuit board 714, a data tape carrier package 716 and a ductile circuit board 718 for gate that is fabricated in a COF process.

[0056] The liquid crystal display panel **712** includes a thin film transistor board **712a**, a color filter board **712b** and liquid crystal (not shown).

[0057] The thin film transistor board **712a** is a transparent glass substrate on which thin film transistors in matrix are formed. A data line is connected with a source terminal of the thin film transistors and a gate line is connected with a gate terminal of the thin film transistors. Furthermore, pixel electrodes made of Indium Tin Oxide, which is a transparent and conductive material, are formed at a drain terminal of the thin film transistors.

[0058] When electric signals are applied to the data line and the gate line, the electric signals are input into the source terminal and the gate terminal of the respective thin film transistor. As the electric signals are input into the thin film transistors, the thin film transistors are respectively turned-on or turned-off, resulting in outputting the electric signals, which are required to form pixels, to the drain terminals.

[0059] The color filter board **712b** is provided to face to the thin film transistor board **712a**. The color filter board **712b** has RGB pixels, which are formed by a thin film process to present desired colors while the light passes through the color filter board **712b**. A surface of the color filter board **712b** is coated with common electrodes made of Indium Tin Oxide.

[0060] When the electricity is applied to the gate and source terminals of the transistor on the thin film transistor board **712a** to turn on the thin film transistor, an electric field is created between the pixel electrodes and common electrodes of the color filter board **712b**. This electric field causes to change an array angle of the liquid crystal injected between the thin film transistor board **712a** and the color filter board **712b**, resulting in that a light permeability depending on the changed array angle also is changed so as to gain a desired pixels.

[0061] A driving signal and a timing signal are applied to the gate line and the data line of the thin film transistor in order to control the array angle of the liquid crystal of the liquid crystal display panel **712** and the time at which the liquid crystal is arranged in the liquid crystal display panel **712**. As shown in FIGS. 3 and 4, the data tape carrier package **716** is attached to the source portion of the liquid crystal display panel **712** to decide a time at which a data driving signal is applied to the liquid crystal display panel **712**. On the other hand, the ductile circuit board **718** for gate, which is fabricated by the COF process, is attached to the gate portion of the liquid crystal display panel **712** to decide a time at which a gate driving signal is applied to the liquid crystal display panel **712**.

[0062] The integrated and printed circuit board **714**, which applies the driving signal to the gate line and the data line as soon as receiving image signals inputted from outside of the liquid crystal display panel **712**, come in contact with the data tape carrier package **278** for the data line in the liquid crystal display panel **712**. A source portion and a gate portion are formed on the integrated and printed circuit board **714**. The source portion receives the image signals from an information process device (not shown) such as a computer, etc. and then provides the data driving signal for the liquid crystal display panel **712**. The gate portion provides the gate driving signal for the gate line of the liquid

crystal display panel **712**. That is, the integrated and printed circuit board **714** generates the gate driving signal and the data signal for driving the liquid crystal display device and the plural timing signals for applying the gate driving signal and the data signal in time, so as to apply the gate driving signal through the ductile circuit board **718** for gate to the gate line of the liquid crystal display panel **712** and the data signal through the data tape carrier package **716** to the data line of the liquid crystal display panel **712**.

[0063] A backlight assembly **720** is disposed under the display unit **710** to supply the light to the display unit **710** uniformly. The backlight assembly **720** includes a line typed lamp **722** that is disposed at a side of the liquid crystal display module **700** and has a thickness which is gradually reduced from an end adjacent to the lamp **272** to the other end being far away from the lamp **722**. The light guide plate **724** is disposed under the liquid crystal display panel **712** so as to guide the light generated by the lamp **722** to the display unit **710** while changing the pathway of the light.

[0064] A plurality of optical sheets **726** is disposed on the light guide plate **724** to make a brightness of the light transmitted from the light-guide plate **724** to the liquid crystal display panel **712** to be uniform. Furthermore, a light reflecting plate **728** is provided under the light guide plate **724** in order to reflect the light, which is leaked from the light guide plate **724**, to the light guide plate **724**, resulting in increasing the light efficiency.

[0065] The display unit **710** and the backlight assembly **720** are fixedly supported by means of a mold frame **730**. The mold frame **730** has a rectangular tetragonal shape and an opening at a top portion thereof. That is, the mold frame **730** has four sidewalls and a bottom wall on which openings are formed so that the integrated and printed circuit board **714** is bent along an outer surface of the mold frame **730** to be received through the openings in the mold frame **730**.

[0066] A chassis **740** is provided for the mold frame **730** in order to fix the integrated and printed circuit board **714** and the gate tape carrier package **718** of the display unit **710** to the bottom wall of the mold frame **730** while to bend the integrated and printed circuit board **714** and the gate tape carrier package **718** toward the outside of the mold frame **730**.

[0067] The chassis **740** has a rectangular tetragonal shape similar to the mold frame **730**, of which an upper surface is opened to expose the liquid crystal display panel **712** and sidewalls are inwardly bent to cover a peripheral surface of the liquid crystal display panel **712**.

[0068] To assemble the liquid crystal display device, firstly, the backlight assembly **720** is received in the mold frame **730**, on which in turn the display unit **710** is disposed. Next, the integrated and printed circuit board **714** connected through the data tape carrier package **716** to the display unit **710** is mounted in the openings formed in the bottom wall of the mold frame **730** while being bent along the outer surface of the sidewall of the mold frame **730**. Finally, the chassis **740** is combined with the mold frame **730** so that the display unit **710** and the backlight assembly **720** are fixed to the mold frame **730**.

[0069] At that time, the ductile circuit board **718** for gate, which is attached to the gate of the display unit **710**, is fixed

to the bottom wall of the mold frame **730** with enclosing the outer surfaces of the mold frame **730**.

[0070] As described above, the color filter board **712b** has a compensative film **713** and a polarizing plate **715** for improving a visual field angle which are disposed on a surface of the color filter board **712b**.

[0071] A member **750** for changing a pathway of the light partially is provided on the polarizing plate **715**. FIG. **5a** is an exploded sectional view of illustrating the member for changing the pathway of the light partially in detail according to the first embodiment of the present invention shown in FIGS. **3** and **4**.

[0072] Referring to FIG. **5a**, a member **750** for changing the pathway of the light partially, which is provided as an upper board of the liquid crystal display panel **712** on the upper surface of the color filter board **712b**, substantially transmits the part of the light in the same direction as that in which the light proceeds, while changing the pathway of the rest of the light. As shown in FIG. **5a**, the member **750** for changing the pathway of the light partially includes a transparent base film **752** and a plurality of projections **754** formed on a bottom surface of the transparent base film **752** that is in contact with the liquid crystal display panel **712** to be placed under the transparent base film **752**.

[0073] The plurality of the projections **754** has a striped shape, which is continuously formed. The projections **754** respectively include a horizontal portion **756a**, a first inclined portion **756b** and a second inclined portion **756c**. The horizontal portion **756a** defines a first region having a striped shape to transmit the first light **L1**, which passes through the liquid crystal display panel **712**, in the same direction as that in which the light proceeds straight ahead. The horizontal portion **756a** may be rendered inclined somewhat if the first light **L1** having passed through the liquid crystal display panel **712** can be substantially transmitted through the horizontal portion **756a** in the same direction as that in which the light proceeds straight ahead. The first inclined portion **756b** is provided at a left side of the horizontal portion **756a** in FIG. **5a**, which defines a second region that changes the pathway of the second light **L2** having passed through the liquid crystal display panel **712** to the left in FIG. **5a** and transmits the second light **L2** left. The second inclined portion **756c** is formed at a right side of the horizontal portion **756a** in FIG. **5a**, which defines a third region that changes the pathway of the third light **L3** having passed through the liquid crystal display panel **712** to the right in FIG. **5a**. As described above, as the first and second inclined portions **756b** and **756c** change the pathway of the light having passed through the liquid crystal display panel **712**, the light displaying images is dispersed uniformly, resulting in improving the visual field angle.

[0074] The horizontal portion **756a** forming the first region, the first inclined portion **756b** forming the second region and the second inclined portion **756c** forming the third region configure a single stripe-shaped region **760a** for changing the pathway of the light. A region **760** for changing the pathway of the light is integrated with the member **750** for changing the pathway of the light partially. Widths of the single regions **760a**, **760b**, **760c** . . . preferably is smaller than a length of a unit pixel.

[0075] Furthermore, the horizontal portion **756a**, the first inclined portion **756b** and the second inclined portion **756c**

are projected from the base film **752** to the liquid crystal display panel **712** and have a mesa shape in a sectional view. The second inclined portion **756c** of the light pathway changing region **760a** and the first inclined portion **756b** of the light pathway changing region **760b** adjacent to the light pathway changing region **760a** define grooves **G** having a triangle shape in a sectional view. The grooves **G** are formed in a striped shape similar to the light pathway changing region **760**. Accordingly, a vertical distance from a line **L1** connecting apexes of the grooves **G** to the horizontal portion **756a** is defined as a height **h** of the mesa shaped projections **754**. In addition, the line **L1** is an extending line connecting bases of the mesa shaped projections to one another.

[0076] A point at which the first inclined portion **756b** and the second inclined portion **756c** extend and are imaginary intersected each other forms an apex of a prism. A vertical distance from the apex of the prism to the base of the projection (for example, a base of the prism) is defined by a height **H** of the prism.

[0077] If a ratio of the height **h** of the mesa shaped projection **754** to the height **H** of the prism is less than 0.05, an effect of changing the pathway of the light is hardly gained by the first and second inclined portions **756b** and **756c**. Furthermore, if the ratio of the height **h** of the mesa shaped projection **754** to the height **H** of the prism is more than 0.7, an effect of straightening the light is hardly achieved. Accordingly, the ratio of the height **h** of the mesa shaped projection **754** to the height **H** of the prism preferably is in a range of about 0.05 to 0.7.

[0078] On the other hand, the first and second inclined portions **756b** and **756c** come in contact with the line **L1** at a predetermined angle. An inner angle at a point at which the first inclined portion **756b** intersects the line **L1** is defined as an angle **A1** and an inner angle at a point at which the second inclined portion **756c** intersects the line **L1** is defined as an angle **A2**. If the angles **A1** and **A2** respectively are less than ten degrees, each area of the first and second inclined portions **756b** and **756c** is significantly increased. It is not preferable that the angles **A1** and **A2** are less than ten degrees since the regions for changing the pathway of the light is wide. To the contrary, if the angles **A1** and **A2** are more than eighty degrees, each area of the first and second inclined portions **756b** and **756c** is significantly decreased. It is not preferable that the angles **A1** and **A2** are more than eighty degrees since the regions for changing the pathway of the light is reduced to hardly improve the brightness of the light according to the visual field angle. Accordingly, the angles **A1** and **A2** preferably are in the range of ten to eighty degrees. At that time, it is possible that the angle **A1** is equal to or different from the angle **A2**.

[0079] In the case that the angle **A1** is different from the angle **A2**, if a sum of the angle **A1** and the angle **A2** is less than twenty degrees, an area of the first and second inclined portions **756b** and **756c** is increased. As a result, the region for changing the pathway of the light is significantly wide. To the contrary, if the sum of the angle **A1** and the angle **A2** is more than one hundred sixty degrees, the first and second inclined portions **756b** and **756c** is significantly decreased. As a result, the region for changing the pathway of the light is reduced to hardly improve the brightness of the light according to the visual field angle. Accordingly, it is preferable that the sum of the angle **A1** and the angle **A2** is in the range of twenty degrees to one hundred sixty degrees.

[0080] The base film 752 and the projections 754 can be integrally formed of an identical material. If the base film 752 is made of the same material as that of the projections 754, it is preferable to use a high-polymer material having a refractive index more than 1.4 and a high transparency as that of the base film 752 and the projection 754. An acrylic resin is exemplified as one of the high-polymer material.

[0081] FIG. 5b is a sectional view of showing a member 850 for changing a pathway of light partially according to the second embodiment of the present invention. The member 850 for changing the pathway of the light partially shown in FIG. 5b is identical with the member 750 for changing the pathway of the light partially shown in FIG. 5a, except that a protective film 852 is coated on the member 750 for changing the pathway of the light partially according to the first embodiment of the present invention to cover the projections 754.

[0082] Referring to FIG. 5b, the member 850 for changing the pathway of the light partially further includes the protective film 852 in order to ensure a stability of the base film 752 when the polarizing plate 715 is attached to the base film 752 including the projections 754.

[0083] It is preferable to form the base film 752 and the protective film 852 respectively with a different material. In the case of forming the base film 752 and the protective film 852 respectively with a different material, preferably, the refractive index of the material of which the base film 752 is made is higher than that of the material of which the protective film 852 is made. For example, the base film 752 is made of the material of which the refractive index is more than 1.5 while the protective film 852 is formed of the material of which the refractive index is less than 1.35. A photosensitive polymer type material is used as the material of the base film 752, of which the refractive index is more than 1.5 and a fluorine-containing polymer type material is used as the material of the protective film 852, of which the refractive index is less than 1.35. An acrylic resin such as a polymethylmethacrylate is used as the photopolymer material and a soluble amorphous fluoropolymer resin is used as the fluorine polymer material. An example of the fluoropolymer resin is available of Teflon AF (a trademark), Dupont Company.

[0084] The protective film 852 is placed between the base film 752 and the polarizing plate 715 to carry out a function of fixing the base film 752 to the polarizing plate 715. A separate member may be used to fix the base film 752 to the polarizing plate 715. When the protective film 852 is made of a material having an adhesiveness, however, the base film 752 can be fixed to the polarizing plate 715 by means of the protective film 852 without use of the separate member. According to the preferred embodiment of the present invention, the protective film 852 can be made of the material having the adhesiveness. The material having the adhesiveness, for example, can be made to contain the fluoride acrylic resin.

[0085] FIG. 6a is a sectional view of showing the member 950 for changing the pathway of the light partially according to the third embodiment of the present invention. The member for changing the pathway of the light partially shown in FIG. 6a is identical with the member 750 for changing the pathway of the light partially according to the first embodiment of the present invention, except that a

fourth region 958 having a striped shape is formed between the light pathway changing regions 760a and 760b shown in FIG. 5a in order to transmit the light in the same direction as the light proceeds straight.

[0086] To describe the member 950 in detail referring to FIG. 6a, the member 950 for changing the pathway of the light partially according to the embodiment of the present invention transmits the part of the light in the same direction as the light proceeds straight similarly to the member 750 for changing the pathway of the light partially of the first embodiment of the present invention and another part of the light through the changed pathway. The member 950 for changing the pathway of the light partially shown in FIG. 6a includes a transparent base film 952 and a plurality of projections 954 that is integrally formed on a bottom surface of the transparent base film 952 to face to the liquid crystal display panel.

[0087] The projections 954 have a striped shape and are continuously formed on the bottom surface of the transparent base film 952. The projections 954 respectively have a first horizontal portion 956a, a first inclined portion 956b and a second inclined portion 956c. A striped shaped-second horizontal portion 958 (or a bottom surface portion) is formed between the projections 954 to be parallel with the first horizontal portion 956a, so as to transmit the light in the same direction as that in which the light proceeds straight. The first horizontal portion 956a and the second horizontal portion 958 define a first region having a striped shape to transmit the first light L1, which passes through the liquid crystal display pane, in the same direction as that in which the light proceeds straight. The first inclined portion 956b is provided at a left side of the first horizontal portion 956a in FIG. 6a, which defines a second region that changes the pathway of the second light L2 having passed through the liquid crystal display panel into the left in FIG. 6a and transmits the second light L2 left. The second inclined portion 956c is formed at a right side of the first horizontal portion 956a in FIG. 6a, which defines a third region that changes the pathway of the third light L3 having passed through the liquid crystal display panel to the right in FIG. 6a. As described above, as the first and second inclined portions 956b and 956c change the pathway of the light having passed through the liquid crystal display panel, the light displaying images is dispersed uniformly, resulting in improving the visual field angle.

[0088] The first and second horizontal portions 956a and 958 forming the first region, the first inclined portion 956b forming the second region and the second inclined portion 956c forming the third region configure a single striped shaped region 960a for changing the pathway of the light. A region 960 for changing the pathway of the light is integrated with the member 950 for changing the pathway of the light partially. Widths of the single regions 960a, 960b, 960c . . . preferably is smaller than a length of a unit pixel.

[0089] Furthermore, the projections 954 respectively including the first horizontal portion 956a, the first inclined portion 956b and the second inclined portion 956c are projected from the base film 952 to the liquid crystal display panel and have a mesa shape in a sectional view. The second inclined portion 956c of the light pathway changing region 960a and the first inclined portion 956b and the second horizontal portion 958 of the light pathway changing region

960b adjacent to the light pathway changing region **960a** define grooves **G'** having a reversed mesa shape in a sectional view. The grooves **G'** are formed in a striped shape to be parallel with one another similarly to the light pathway changing region **960**. Accordingly, each bottom surface of the grooves **G'** configures the second horizontal portion **958**.

[0090] At that time, the first horizontal portion **956a**, the first inclined portion **956b**, the second inclined portion **956c** and the second horizontal portion **958** define a single light pathway changing region of which width preferably is smaller than a length of a unit pixel.

[0091] FIG. 6b is a sectional view of showing a member **1050** for changing a pathway of light partially according to the fourth embodiment of the present invention. The member for changing the pathway of the light partially shown in FIG. 6b is identical with the member for changing the pathway of the light partially shown in FIG. 6a, except that the member **1050** for changing the pathway of the light partially further includes a protective film **1052** for covering the projections **954** while flattening the member **950** as shown in FIG. 5b.

[0092] FIG. 7a is a sectional view of showing the member **1150** for changing the pathway of the light partially according to the fifth embodiment of the present invention.

[0093] Referring to FIG. 7a, the member **1150** for changing the pathway of the light partially according to the embodiment of the present invention transmits a part of the light at a first region **1156b** thereof in the same direction as that in which the light proceeds straight ahead and the other part of the light through a changed pathway at a second region **1156c**. As shown in FIG. 7a, the member **1150** for changing the pathway of the light partially includes a transparent base film **1152** and a plurality of projections **1160** formed on a bottom surface of the transparent base film **1152** to face to the liquid crystal display panel that is placed under the transparent base film **1152**.

[0094] The plurality of the projections **1160** has a striped shape, which is continuously formed. The projections **1160** respectively include a first inclined portion **1156b** having a relative long length and a second inclined portion **1156c** having a relative short length. The first inclined portion **1156b** transmits a first light **L1**, which has passed through the liquid crystal display panel, in the same direction as that in which the light proceeds straight. The second inclined portion **1156c** defines a second region that changes the pathway of the light, which has passed through the liquid crystal display panel, to the right in FIG. 7a. As described above, as the first and second inclined portions **1156b** and **1156c** change the pathway of the light having passed through the liquid crystal display panel, the light displaying images is dispersed uniformly, resulting in improving the visual field angle.

[0095] The first inclined portion **1156b** forming the first region and the second inclined portion **1156c** forming the second region configure a single striped shaped region **1160a** for changing the pathway of the light. Widths of the single regions **1160a**, **1160b**, **1160c** . . . preferably is smaller than a length of a unit pixel.

[0096] The first and second inclined portions **1156b** and **1156c** are projected from the base film **1152** to the liquid crystal display panel, of which a profile is an asymmetric triangle shape.

[0097] On the other hand, the first and second inclined portions **1156b** and **1156c** come in contact with the imaginary line **L1'** that connects apexes of the projections **1160** with one another at predetermined angles. An inner angle at a point at which the first inclined portion **1156b** meets the imaginary line **L1'** is defined as an angle **A1'** and an inner angle at a point at which the second inclined portion **1156c** meets the imaginary line **L1'** is defined as an angle **A2'**. As described above, the angles **A1'** and **A2'** respectively are in the range of ten degrees to eighty degrees.

[0098] FIG. 7b is a sectional view of showing a member **1250** for changing a pathway of light partially according to the sixth embodiment of the present invention. The member **1250** for changing the pathway of the light partially according to the embodiment of the present invention is identical with the member for changing the pathway of the light partially shown in FIG. 7a, except that the member **1250** for changing the pathway of the light partially further includes a protective film **1252** for flattening the member **1150** as shown in FIG. 5b.

[0099] FIG. 8A is a sectional view of showing a member **1350** for changing a pathway of light partially according to the seventh embodiment of the present invention. The member **1350** for changing the pathway of the light partially according to the embodiment of the present invention is identical with the member for changing the pathway of the light partially shown in FIG. 7a, except that the light pathway changing unit of the member **1350** for changing the pathway of the light partially further includes a horizontal portion **1358** between the first inclined portion **1356b** and the second inclined portion **1356c** of the region **1380** for changing the pathway of the light as shown in FIG. 7a. The first inclined portion **1356b**, the second inclined portion **1356c**, and the horizontal portion **1358** are formed on the transparent base film **1352** as described in FIG. 6A. The first inclined portion **1356b**, the second inclined portion **1356c** and the horizontal portion **1358** configure single light pathway changing regions **1360a** and **1360b** respectively having a striped shape.

[0100] FIG. 8B is a sectional view of showing a member **1450** for changing a pathway of light partially according to the eighth embodiment of the present invention. The member **1450** for changing the pathway of the light partially according to the embodiment of the present invention is identical with the member for changing the pathway of the light partially shown in FIG. 8a, except that the member **1450** for

[0101] changing the pathway of the light partially further includes a protective film **1452** for flattening the member **1350** for changing the pathway of the light as shown in FIG. 8a.

[0102] FIG. 9 is a plan view of showing an arrangement of the thin film transistor board **712a** and the member **750** for changing the pathway of the light as shown in FIG. 3. In FIG. 9, an arrow **A** indicates a direction of liquid crystal to be orientated in a twisted nematic mode type of the liquid crystal display panel and an arrow **B** indicates a lengthwise direction of the striped shaped regions **760a**, **760b** . . . for changing the pathway of the light in the member **750** for changing the pathway of the light partially. As shown in FIG. 9, the member **750** for changing the pathway of the light partially is arranged in the lengthwise direction on the

liquid crystal display panel and attached to the color filter board **712b** so that the lengthwise direction of the member **750** is perpendicular to a tilting direction of a panel on which an electric field is vertically created and which is horizontally arranged.

[**0103**] Even though the relationship of the member **750** and the liquid crystal display panel is described in relation only to the first embodiment of the present invention, it is understood that the relationship of the member for changing the pathway of the light partially and the liquid crystal display panel is preferably applied to the second, third and fourth embodiments of the present invention.

[**0104**] The member **750** for changing the pathway of the light partially can be easily attached to the polarizing plate **715** in a laminating method by means of rollers. Especially, when the adhesive films **850** and **1050** of the members **850** and **1050** for changing the pathway of the light partially according to the second and fourth embodiments of the present invention have an adhesiveness, the adhesive protective films **852** and **1052** attaches the member **750** to the polarizing plate **715** in the laminating method so that the adhesive protective films **852** and **1052** make the members **850** and **1050** come in close contact with the polarizing plate **715**.

[**0105**] Hereinafter, a process of forming images in the liquid crystal display device according to the embodiments of the present invention will be described.

[**0106**] As receiving the images signals from an outside of the liquid crystal display panel **712**, the integrated and printed circuit board **714**, which applies driving signals to the gate lines and the data lines, generates a gate driving signal and a data signal for driving the liquid crystal display device and plural timing signals for applying the gate driving signal and the data signal in time. The gate driving signals are applied through the ductile circuit board **718** for the gate to the gate lines of the liquid crystal display panel **712** and the data signals are applied through the data tape carrier package **716** to the data lines of the liquid crystal display panel **712**.

[**0107**] When electric signals are inputted to the data lines and the gate lines, the electric signals are inputted into the source terminals and the gate terminals of the respective thin film transistor. As the electric signals are inputted into the thin film transistors, the thin film transistors are respectively turned-on or turned-off, resulting in outputting the electric signals, which are required to form pixels, to the drain terminals.

[**0108**] When the electricity is applied to the gate terminals and the source terminals of the transistors on the thin film transistor board **712a** to turn on the thin film transistors, an electric field is created between the pixel electrodes and the common electrodes of the color filter board **712b**. This electric field causes to change an array angle of the liquid crystal injected between the thin film transistor board **712a** and the color filter board **712b**, resulting in that a light permeability depending on the array angle is also changed.

[**0109**] The light that is generated by the line typed lamp **722** of the backlight assembly **720** disposed under the display unit **710** is transmitted to the light guide plate **724**. The light guide plate **724** guides the light to the display unit **710** while changing the pathway of the light.

[**0110**] The light passing through the light guide plate **724** is made to be uniform by means of the optical sheets **726** and is transmitted to the liquid crystal display panel **712**. When the light enters the liquid crystal display panel **712**, the liquid crystal controls a transmission quantity of the light. The light that has passed through the liquid crystal display panel **712** again passes through the color filter board **712b** to form the images. The light forming the images has an improved visual field angle, in which the gray scale inversion is restrained, while passing through the compensative film **713** and the polarizing plate **715**, for instance the member **750** for changing the pathway of the light partially. As a result, the light can present the preferred images. Simulations of the gray scale inversion according to the change of the visual field angle.

[**0111**] The member **750** for changing the pathway of the light according to the first embodiment of the present invention was prepared. A phase difference ($\Delta n \cdot d$) of the liquid crystal adopted to the liquid crystal display panel **712** was about 0.363 (herein, Δn is a refractive index and d is a gap of liquid crystal cells). An anisotropy (ΔE) of the liquid crystal was about 5.9. A pre-tilt angle of the liquid crystal, which is the orientation angle of the liquid crystal, was about 5 in the state of that the electric field is not created and an orientation screen had a left-handed characteristic.

[**0112**] The refractive index of the material used for making the member **750** for changing the pathway of the light partially was about 1.49. A size of the pixel was 300 μm and a width (a pitch) of the single light pathway changing region of the member **750** was 30 μm . The brightness of the light depending on voltages was measured with changing the angles **A1** and **A2** and the ratio h/H of the height h of the projection **754** and the height H of the prism. Seven values (1.7V, 1.9V, 2.2V, 2.5V, 2.8V, 3.3V and 5.0V) of the voltages were selected in a range of 1.7 voltages to 5.0 voltages and respectively applied to the liquid crystal display panel in order to measure the brightness of the light.

[**0113**] In a phase difference film of the polarizing plate **215**, R_e was 0 nm, which is presented by an equation $d^*(N_x - N_y)$ wherein d is a thickness of the phase difference film, N_x is a refractive index in a direction of an axis x , and N_y is a refractive index in a direction of an axis y , and R_{th} was 40 nm, which is presented by an equation $d^*(N_x - N_z)$ wherein d is a thickness of the phase difference film, N_x is a refractive index in a direction of an axis x , and N_z is a refractive index in a direction of an axis z . The discotic layer that is the compensative film **713** had a refractive index of about 0.05 and a thickness of about 2.0 μm . The discotic liquid crystal had a light axis of which a pole angle was about 7.5 when $z=0$ and about 52.5 when $z=d$.

[**0114**] In samples 1, 2, 3, and 4, the inner angle of the projection and the ratio h/H of the height h of the projection and the height H of the prism are presented in a table 1 as follows. Furthermore, a comparative sample 1 that has no the member for changing the pathway of the light partially according to the present invention was used for measuring the brightness of the light and the gray scale inversion in the liquid crystal display device. A comparative sample 2 was the light pathway changing member in which the ratio h/H of the height h of the projection and the height H of the prism is 1.

TABLE 1

	A1/A2 (angles)	Ratio of h/H (%)
Sample 1	45/45	30
Sample 2	30/30	30
Sample 3	45/30	30
Sample 4	45/45	60
Comparative sample 1	—	—
Comparative sample 2	45/45	100

[0115] FIGS. 10a to 10c are graphs of showing a change of the brightness of the sample 1 according to the visual field angle. FIGS. 11a to 11c are graphs of showing a change of the brightness of the sample 2 according to the visual field angle. FIGS. 12a to 12c are graphs of showing a change of the brightness of the sample 3 according to the visual field angle. FIGS. 13a to 13c are graphs of showing a change of the brightness of the sample 4 according to the visual field angle. FIGS. 14a to 14c are graphs of showing a change of the brightness of the comparative sample 1 according to the visual field angle. FIGS. 15a to 15c are graphs of showing a change of the brightness of the comparative sample 2 according to the visual field angle.

[0116] FIGS. 10a, 11a, 12a, 13a, 14a and 15a respectively show the change of the brightness according to the change of the visual field angle in a vertical direction, FIGS. 10b, 11b, 12b, 13b, 14b and 15b respectively are an exploded view of showing the change of the brightness of FIGS. 10a, 11a, 12a, 13a, 14a and 15a, and FIGS. 10c, 11c, 12c, 13c, 14c and 15c respectively show the change of the brightness according to the change of the visual field angle in a horizontal direction.

[0117] Referring to FIGS. 14A to 14C, it can be understood that in the case of the comparative sample 1 without the light pathway changing member according to the present invention, the brightness increases in the horizontal direction according to the change of the visual field angle as the applied voltage is increased, but the gray scale inversion is broken out near the angle of -40 degrees in the vertical direction.

[0118] Meanwhile, referring to FIGS. 15a to 15c, since the member for changing the pathway of the light partially does not have the first horizontal portion to move the part of

the light straight, the brightness is degraded in the vertical and horizontal directions at a center portion of the liquid crystal display panel.

[0119] Meanwhile, referring to FIGS. 10A to 13C, in the liquid crystal display device having the member for changing the pathway of the light partially according to the embodiments of the present invention, the brightness is preferably changed in the vertical and horizontal directions. Especially, as shown in FIGS. 10b, 11b, 12b and 13b, the gray scale inversion hardly occurs.

[0120] According to the present invention, when the light passing through the liquid crystal is transmitted through the member for changing the pathway of the light partially, the part of the light is transmitted in the same direction as the light proceeds straight and the rest of the light is refracted and transmitted in the changed direction. Since the part of the light is transmitted straight and the rest of the light is transmitted along the changed pathway, the brightness in the center portion of the liquid crystal display panel is excellent and also the brightness in the vertical and horizontal directions is improved. Furthermore, the gray scale inversion phenomenon in which the brightness is decreased when the voltage increases is restrained by means of the light of which the part is refracted and transmitted along the change pathway, resulting in displaying the images having a desired quality.

[0121] Although the preferred embodiments of the present invention have been described, it is understood that the present invention should not be limited to these preferred embodiments but various changes and modifications can be made by one skilled in the art within the spirit and scope of the present invention as hereinafter claimed.

1-21. (Cancelled)

22. A liquid crystal display device, comprising:

- a front case;
- a liquid crystal display panel arranged adjacent to the front case, the liquid crystal display panel includes a member to change a pathway of light;
- a back light assembly comprising a lamp to generate the light for the liquid crystal display panel; and
- a rear case arranged opposite the front case.

* * * * *

专利名称(译)	液晶显示装置		
公开(公告)号	US20050024565A1	公开(公告)日	2005-02-03
申请号	US10/846993	申请日	2004-05-17
[标]申请(专利权)人(译)	黄某SUN 山村信行 金相IL		
申请(专利权)人(译)	黄某-SUN 山村信行 金相IL		
当前申请(专利权)人(译)	三星DISPLAY CO. , LTD.		
[标]发明人	HWANG IN SUN NOBUYUKI YAMAMURA KIM SANG IL		
发明人	HWANG, IN-SUN NOBUYUKI, YAMAMURA KIM, SANG-IL		
IPC分类号	G02F1/13363 G02F1/1335		
CPC分类号	G02F1/133504		
优先权	1020010013875 2001-03-17 KR		
其他公开文献	US7327413		
外部链接	Espacenet USPTO		

摘要(译)

本发明公开了一种根据视场角改变光路以放松灰度反转并用于扭曲向列模式的液晶显示装置的装置，以及具有该装置的液晶显示装置。光路部分改变装置设置在液晶显示板上，部分地改变光路，使得一部分光基本上在与光进行相同的方向上传输，而其余的光通过改变而传输路径，以便根据液晶显示面板的视场角改变光的亮度，以在光通过液晶显示面板时抑制图像的灰度反转，从而在液晶上制作图像显示屏。通过改变的路径传输的其余光导致获得液晶显示板的视场角，同时抑制图像的灰度反转以及通过液晶显示板的光的一部分。与透过液晶显示板中心的光的方向相同。

