



(19) **United States**

(12) **Patent Application Publication**  
**Lim**

(10) **Pub. No.: US 2003/0112387 A1**

(43) **Pub. Date: Jun. 19, 2003**

(54) **LIQUID CRYSTAL DISPLAY DEVICE  
HAVING SEAL PATTERN PREVENTING  
ELECTROLYTIC CORROSION AND  
METHOD OF FABRICATING THE SAME**

**Publication Classification**

(51) **Int. Cl.<sup>7</sup> ..... G02F 1/1339**  
(52) **U.S. Cl. .... 349/110**

(76) **Inventor: Joo Soo Lim, Kyongsangbuk-do (KR)**

Correspondence Address:  
**MORGAN LEWIS & BOCKIUS LLP  
1111 PENNSYLVANIA AVENUE NW  
WASHINGTON, DC 20004 (US)**

(21) **Appl. No.: 10/294,777**

(22) **Filed: Nov. 15, 2002**

(30) **Foreign Application Priority Data**

Dec. 19, 2001 (KR) ..... 2001-0088558

(57) **ABSTRACT**

A liquid crystal display device having a seal pattern preventing electrolytic corrosion and a method of fabricating the same are disclosed in the present invention. The liquid crystal display device includes first and second substrates, a plurality of gate lines, a passivation layer on the gate lines, a first transparent conductive layer on the passivation layer, a black matrix at an inner surface of the second substrate, a second transparent conductive layer on the black matrix, and a sealant covering at least portions of the black matrix and the first and second transparent conductive layers.

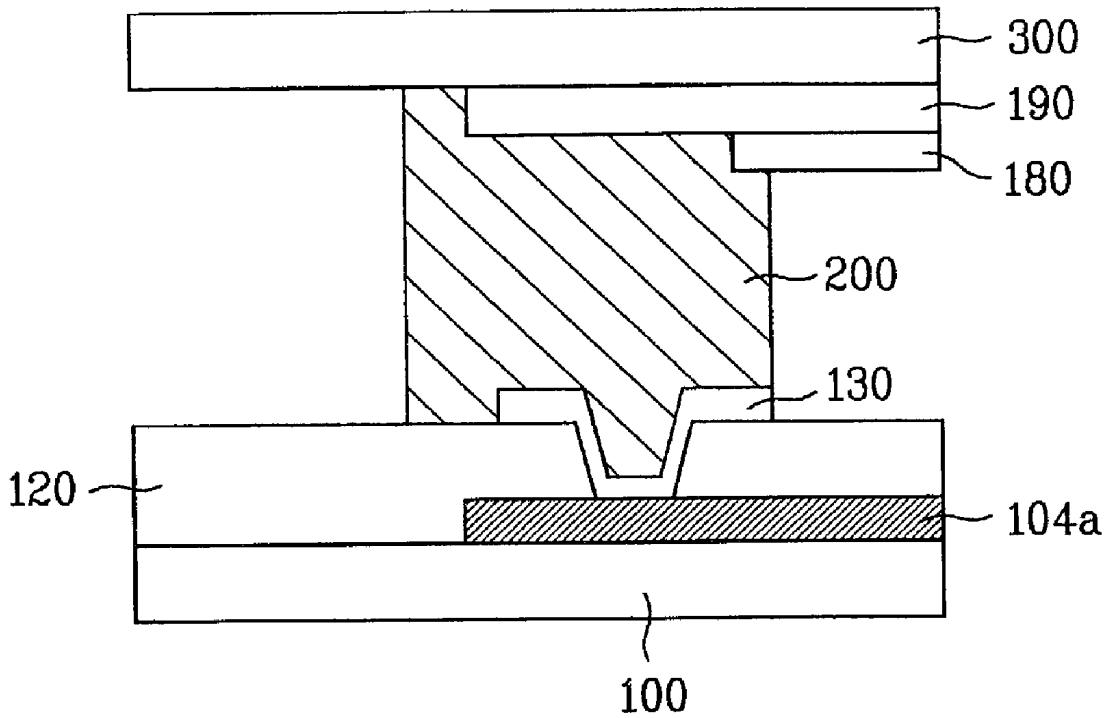

FIG. 1  
Related Art

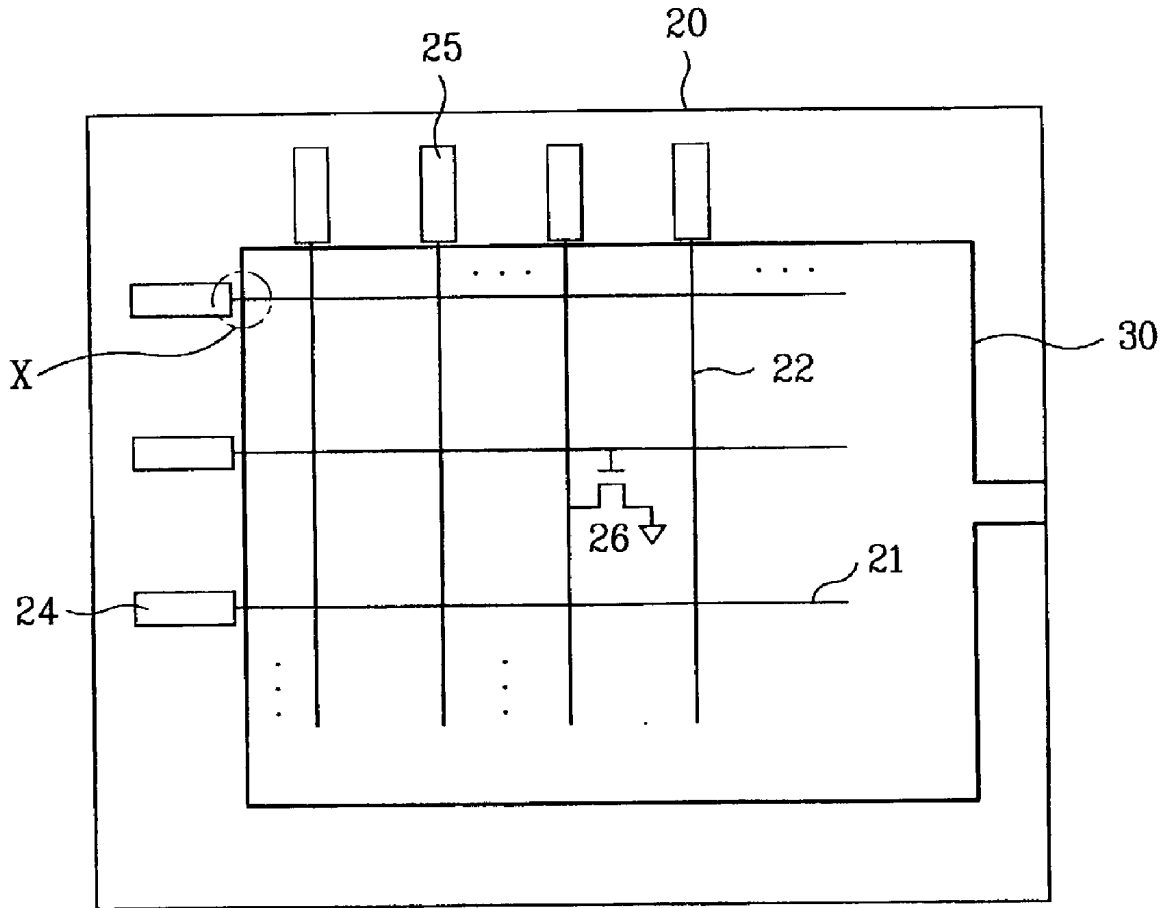

FIG. 2  
Related Art

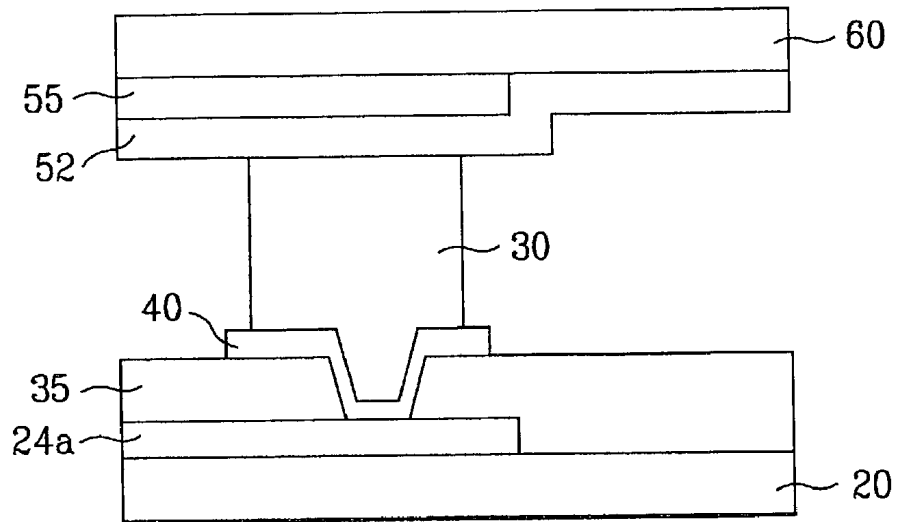

FIG. 3  
Related Art

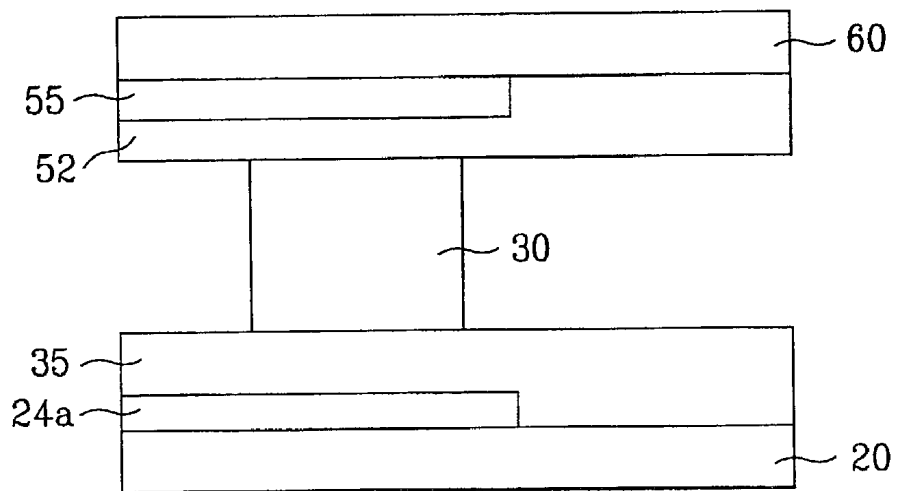

FIG. 4

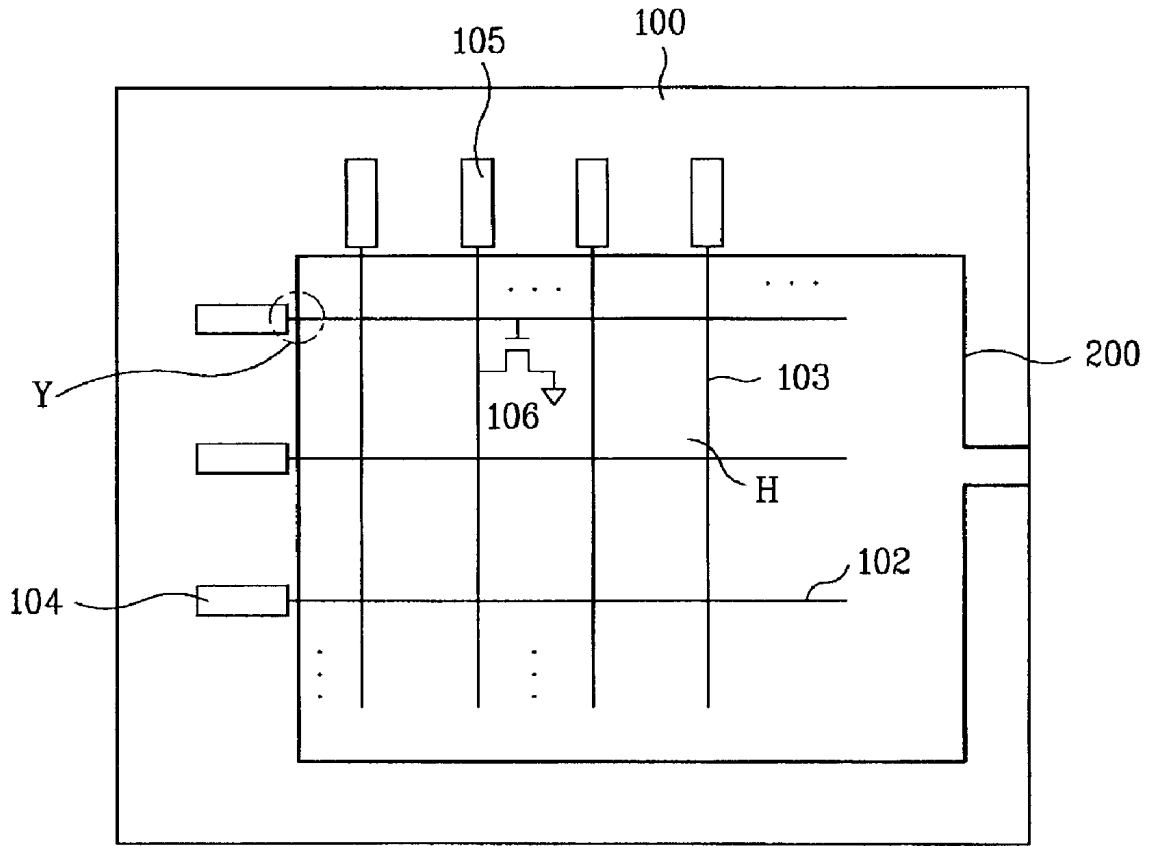

FIG. 5

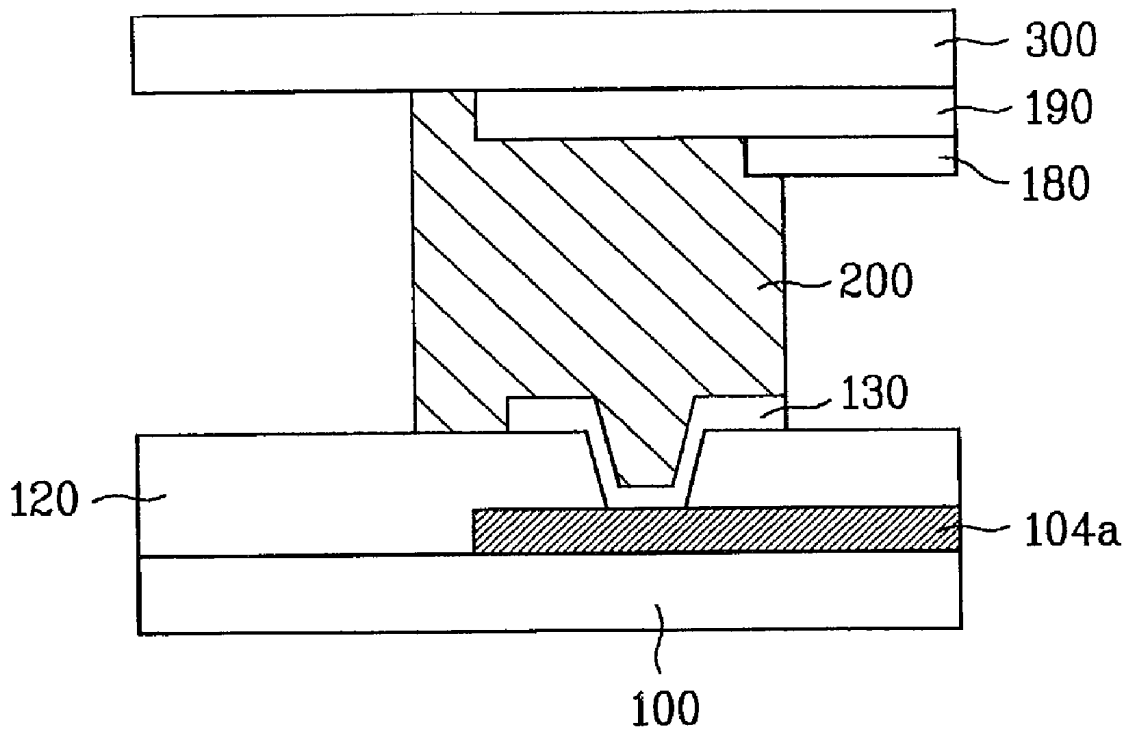

FIG. 6

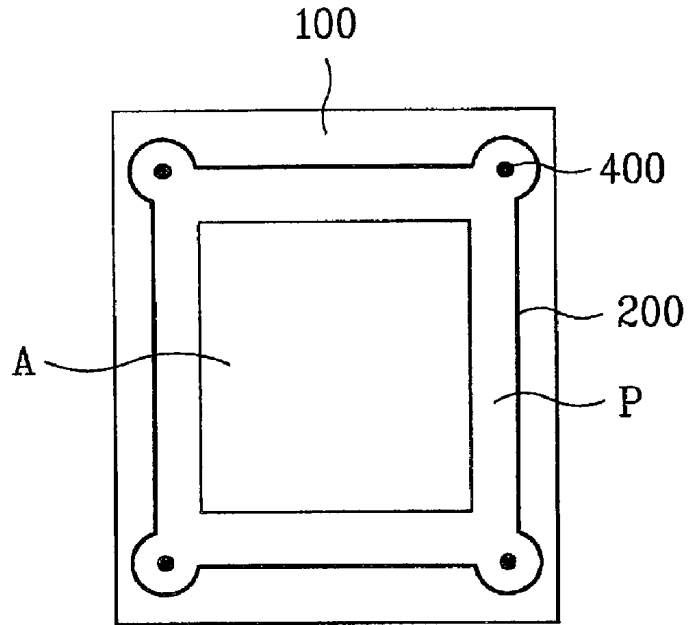
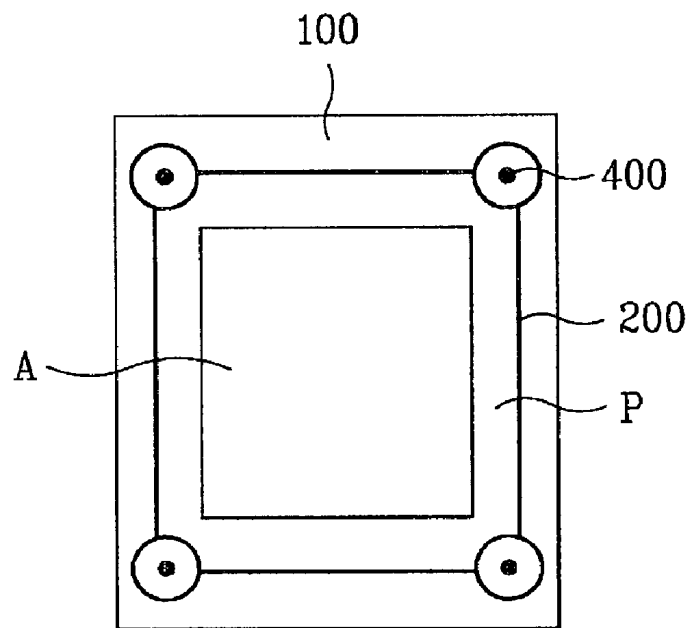

FIG. 7



**LIQUID CRYSTAL DISPLAY DEVICE HAVING SEAL PATTERN PREVENTING ELECTROLYTIC CORROSION AND METHOD OF FABRICATING THE SAME**

[0001] This application claims the benefit of the Korean Application No. P2001-088558 filed on Dec. 29, 2001, which is hereby incorporated by reference.

**BACKGROUND OF THE INVENTION**

[0002] 1. Field of the Invention

[0003] The present invention relates to a display device, and more particularly, to a liquid crystal display device having a seal pattern preventing electrolytic corrosion and a method of fabricating the same.

[0004] 2. Discussion of the Related Art

[0005] Generally, a Braun tube, also known as a cathode ray tube (CRT), has been most widely used as a display device because it can easily realize colors and has a fast operation speed. Therefore, the Braun tube has been a major display device for a TV monitor and a computer monitor.

[0006] However, the Braun tube (CRT) consumes too much power and has a large volume due to its structural limitation of maintaining a space between an electron gun and a screen. In addition, the Braun tube is too heavy to be portable. In order to resolve such problems or disadvantages of the Braun tube (CRT), various display devices have been developed, such as a TFT-LCD panel, which is currently in practical use.

[0007] The TFT-LCD panel can be fabricated thin for ultra-thin display devices, such as wall-mountable television sets. Additionally, the TFT-LCD panel has light weight and consumes considerably less power than that of the Braun tube (CRT). Thus, the TFT-LCD panel can be applied to a display screen of a notebook computer, which can be operated by a battery. As a result, the TFT-LCD panel is considered to be the next generation display device.

[0008] A fabrication of the TFT-LCD panel for a liquid crystal display device includes a TFT array process for forming switches applying pixel unit signals, a color filter process for forming a color filter array for realizing colors, and a liquid crystal cell process for forming unit liquid crystal cells driven by signals by adding a driving circuit to the completed TFT and color filter substrates.

[0009] The liquid crystal cell process will be described as follows. An alignment material is coated on the completed TFT and color filter substrates. A rubbing process is then carried out on the coated alignment material to provide liquid crystal molecules with uniform directions. Then, a cell gap forming process is carried out to maintain a space between the two substrates. Subsequently, an assembly process for bonding the two substrates to each other and a cell cutting process for cutting the bonded substrates by a cell unit are carried out. Thereafter, liquid crystals are injected in the unit cell, and polarizing plates are attached to both sides of the unit cell to complete the liquid crystal cell process.

[0010] The cell cutting process will now be described in detail.

[0011] The cell cutting process is to cut and separate the substrates to cell units after the bonding process. In a conventional TN mode, the cutting process by cell unit is carried out after liquid crystals are injected in a plurality of the cells. However, as a cell increases in size, liquid crystals are injected after the unit cell cutting process.

[0012] The cell cutting process includes a scribing process for forming a cutting line on a glass substrate using a diamond pen having a hardness greater than that of glass, and a breaking process for cutting the glass by applying external pressure.

[0013] A liquid crystal display device according to the related art is explained with reference to the accompanying drawings as follows.

[0014] **FIG. 1** illustrates a schematic view of a TFT substrate for a liquid crystal display device according to a related art.

[0015] Referring to **FIG. 1**, gate and data lines **21** and **22** are formed on a first substrate **20** to vertically cross one another. Gate and data pads **24** and **25** are formed at the ends of the gate and data lines **21** and **22**, respectively.

[0016] A thin film transistor **26** acting as a switching device is formed at each pixel area defined by the crossing point of the gate and data lines **21** and **22**. A plurality of the pixel areas form active areas representing an image.

[0017] A seal pattern **30** is formed on the first substrate **20**. The seal pattern **30** is formed on a liquid crystal margin area of a liquid crystal display panel.

[0018] In this case, the seal pattern **30** has a liquid crystal injection inlet for injecting liquid crystals in a later process.

[0019] Although it is not shown in the drawing, a black matrix, a color filter, a common electrode, and an alignment layer are formed on a second substrate, which is to be bonded and facing into the first substrate **20**. The seal pattern **30** may be formed on the same area of the second substrate.

[0020] **FIG. 2** illustrates a cross-sectional view of portion 'X' shown in **FIG. 1**.

[0021] Referring to **FIG. 2**, a gate pad pattern **24a** formed of the same material as a gate line is formed on a first substrate **20**. A passivation layer **35** is formed on the gate pad pattern **24a**.

[0022] Subsequently, the passivation layer **35** having a contact hole exposing a portion of the gate pad pattern **24a** is formed on the entire surface of the first substrate **20**. A pixel electrode **40** formed of indium tin oxide (ITO) is formed in the contact hole and on the passivation layer **35** adjacent to the contact hole. A seal pattern **30** is formed on the pixel electrode **40**.

[0023] In this case, the contact hole is formed to improve adhesion between the seal pattern **30** and an organic layer, which is used as the passivation layer.

[0024] A black matrix **55** for shielding light is formed on the inner surface of a second substrate **60** facing into the first substrate **20**. A common electrode **52** for simultaneously driving liquid crystals and the pixel electrode **40** is formed on the entire surface of the second substrate **60** including the black matrix **55**.

[0025] FIG. 3 illustrates a cross-sectional view of portion 'X' shown in FIG. 1 to which a chip on glass (COG) method is applied according to the related art. Herein, the same elements of FIG. 2 are represented by the same numerals for simplicity.

[0026] Referring to FIG. 3, a gate pad pattern 24a formed of the same material as a gate line is formed on a first substrate 20. A passivation layer 35 is formed on the entire surface of the first substrate 20 including the gate pad pattern 24a.

[0027] A black matrix 55 for shielding light is formed on the inner surface of a second substrate 60 facing into the first substrate 20. A common electrode 52 for simultaneously driving liquid crystals and the pixel electrode 40 is formed on the entire surface of the second substrate 60 including the black matrix 55. A seal pattern 30 is coated on one of the common electrode 52 and the pixel electrode 40.

[0028] However, the liquid crystal display device according to the related art has the following problem or disadvantage.

[0029] First of all, when the liquid crystal display device is driven for about 24 hours for a reliability test in high temperature and high humidity, after completion of the liquid crystal cell process, water or moisture may penetrate into the cell gap between the first and second substrates 20 and 60. This is because the pixel electrode 40, the common electrode 52, and the black matrix 55 formed of electrically conductive materials are formed outside the sealant 30. Therefore, the electrically conductive black matrix 55 and the gate pad pattern 24a may be deteriorated by electrolytic corrosion.

#### SUMMARY OF THE INVENTION

[0030] Accordingly, the present invention is directed to a liquid crystal display device having a seal pattern preventing electrolytic corrosion and a method of fabricating the same that substantially obviates one or more of problems due to limitations and disadvantages of the related art.

[0031] Another object of the present invention is to provide a liquid crystal display device having a seal pattern preventing electrolytic corrosion and a method of fabricating the same that can be stably driven by forming a sealant pattern on a periphery of the entire patterns made of electrically conductive materials, thereby preventing electrolytic corrosion of the electrically conductive materials during a reliability test in high temperature and high humidity.

[0032] Additional features and advantages of the invention will be set forth in the description which follows and in part will be apparent from the description, or may be learned by practice of the invention. The objectives and other advantages of the invention will be realized and attained by the structure particularly pointed out in the written description and claims hereof as well as the appended drawings.

[0033] To achieve these and other advantages and in accordance with the purpose of the present invention, as embodied and broadly described, a liquid crystal display device includes first and second substrates, a plurality of gate lines on the first substrate, a passivation layer on the gate lines, a first transparent conductive layer on the passivation layer, a black matrix at an inner surface of the second

substrate, a second transparent conductive layer on the black matrix, and a sealant covering at least portions of the black matrix and the first and second transparent conductive layers.

[0034] In another aspect of the present invention, a method of forming a liquid crystal display device includes forming first and second substrates, forming a plurality of gate lines on the first substrate, forming a passivation layer on the gate lines, forming a first transparent conductive layer on the passivation layer, forming a black matrix at an inner surface of the second substrate, forming a second transparent conductive layer on the black matrix, and forming a sealant covering at least portions of the black matrix and the first and second transparent layers.

[0035] It is to be understood that both the foregoing general description and the following detailed description are exemplary and explanatory and are intended to provide further explanation of the invention as claimed.

#### BRIEF DESCRIPTION OF THE DRAWINGS

[0036] The accompanying drawings, which are included to provide a further understanding of the invention and are incorporated in and constitute a part of this application, illustrate embodiments of the invention and together with the description serve to explain the principle of the invention.

[0037] In the drawings:

[0038] FIG. 1 illustrates a schematic layout of a TFT substrate in a liquid crystal display device according to a related art;

[0039] FIG. 2 illustrates a cross-sectional view of portion 'X' shown in FIG. 1;

[0040] FIG. 3 illustrates a cross-sectional view of portion 'X' shown in FIG. 1 to which a chip on glass (COG) method is applied according to the related art;

[0041] FIG. 4 illustrates a layout of a liquid crystal display device according to the present invention;

[0042] FIG. 5 illustrates a cross-sectional view of portion 'Y' shown in FIG. 4; and

[0043] FIGS. 6 and 7 illustrate layouts of the seal patterns in the liquid crystal display device according to the present invention.

#### DETAILED DESCRIPTION OF THE ILLUSTRATED EMBODIMENTS

[0044] Reference will now be made in detail to the illustrated embodiments of the present invention, examples of which are illustrated in the accompanying drawings. Wherever possible, the same reference numbers will be used throughout the drawings to refer to the same or like parts.

[0045] FIG. 4 illustrates a layout of a liquid crystal display device according to the present invention.

[0046] As shown in FIG. 4, a liquid crystal panel includes a first substrate 100 attached to a second substrate (not shown). A plurality of gate and data lines 102 and 103 cross one another on the first substrate 100 to define unit pixel

areas H, respectively. A thin film transistor **106** for driving liquid crystals is formed at each intersection of the gate and data lines **102** and **103**.

[0047] Gate and data pads **104** and **105** are formed at the ends of a plurality of the gate and data lines **102** and **103**, respectively.

[0048] A seal pattern **200** is formed at a seal area, which is located at the periphery of the liquid crystal display panel, by depositing a sealant using a silk screen printing method through a seal mask. The seal pattern **200** may also be formed by using a dispensing method.

[0049] The first substrate **100** is divided into an active area and a seal area. The seal pattern **200** may be formed on either the first substrate **100** or the second substrate (not shown).

[0050] In this case, the seal pattern **200** according to the present invention is formed to surround the outer portions of the gate and data pads **104** and **105**.

[0051] FIG. 5 illustrates a cross-sectional view of portion 'Y' shown in FIG. 4.

[0052] Referring to FIG. 5, first and second substrates **100** and **300** face into each other. A gate pad pattern **104a** is formed on the first substrate **100**. A passivation layer **120** is formed on the entire surface of the first substrate **100** and has a contact hole exposing a portion of the surface of the gate pad pattern **104a**. A first transparent conductive layer **130** formed of ITO is formed in and outside the contact hole.

[0053] Herein, the first transparent conductive layer **130** is a pixel electrode. The passivation layer **120** may be formed of an organic insulating layer, such as BCB or photoacrylate. A black matrix **190** is formed to prevent light leakage on the inner surface of the second substrate **300** facing into the first substrate **100**.

[0054] A second transparent conductive layer **180**, simultaneously driving the liquid crystals along with the first transparent conductive layer **130**, is formed on the second substrate **300** including the black matrix **190**.

[0055] In this case, the second transparent conductive layer **180** is a common electrode. The black matrix **190** is formed at least about 2.0 mm inside the edge of the second substrate **300**.

[0056] A seal pattern **200** is formed to surround the peripheries of the black matrix **190**, the first transparent conductive layer **130**, and the gate pad pattern **104a**.

[0057] More specifically, the first transparent conductive layer **130**, the gate pad pattern **104a** formed of electrically conductive materials are formed to be located inside the seal pattern **200**, thereby preventing electrolytic corrosion during a reliability test in high temperature and high humidity. This may also be applicable to a chip on glass (COG) package, a tape-automated bonding (TAB) package, and the like.

[0058] FIGS. 6 and 7 illustrate layouts of the seal patterns in the liquid crystal display device according to the present invention.

[0059] As shown in FIGS. 6 and 7, an active area A and a pad area P are formed on a first substrate **100**. The active area A includes a plurality of pixel areas defined by a plurality of gate and data lines vertically crossing one

another to represent an image. A pad area P includes the end areas of the gate and data lines around the periphery of the active area A.

[0060] A seal pattern **200** is formed at the periphery of the pad area P. The seal pattern **200** may be formed in a dot type conductive layer **400** for applying a voltage to a transparent conductive layer (not shown) formed on a second substrate (not shown) facing into the first substrate **100**, so as to drive the liquid crystal layer. Herein, the dot type conductive layer **400** may be formed of silver (Ag) having excellent electric conductivity.

[0061] Meanwhile, the seal pattern **200** is formed to surround the dot type conductive layer **400**. The corners of the seal pattern **200** are round so as to surround the dot type conductive layer **400**.

[0062] More specifically, as shown in FIG. 6, the seal pattern **200** may be formed in a dumbbell or rectangular shape to have the dot type conductive layers **400** formed therein. However, the seal pattern **200** may also be formed in any other shapes including a polygonal shape as long as it surrounds the dot type conductive layers **400**. On the other hand, as shown in FIG. 7, the area of the seal pattern **200**, in which the dot type conductive layers **400** are formed, is formed in a doughnut shape, so as to allow the seal pattern **200** to surround the dot type conductive layers **400**.

[0063] Accordingly, the liquid crystal display device according to the present invention has the following advantages or effects.

[0064] The gate pad, the transparent conductive layer, and the black matrix formed of electrically conductive materials are formed to be located inside the seal pattern, thereby preventing electrolytic corrosion of the black matrix or conductive materials during a reliability test in high temperature and high humidity.

[0065] Also, the seal pattern is formed to surround the dot type conductive layer, thereby preventing electrolytic corrosion of the conductive materials, which is caused by the penetration of water.

[0066] Furthermore, the present invention improves a stability in driving the liquid crystal display device and its image quality.

[0067] It will be apparent to those skilled in the art that various modifications and variations can be made in the liquid crystal display device having a seal pattern preventing electrolytic corrosion and the method of fabricating the same of the present invention without departing from the spirit or scope of the inventions. Thus, it is intended that the present invention covers the modifications and variations of this invention provided they come within the scope of the appended claims and their equivalents.

What is claimed is:

1. A liquid crystal display device, comprising:
  - first and second substrates;
  - a plurality of gate lines on the first substrate;
  - a passivation layer on the gate lines;
  - a first transparent conductive layer on the passivation layer;

- a black matrix at an inner surface of the second substrate;  
 a second transparent conductive layer on the black matrix;  
 and  
 a sealant covering at least portions of the black matrix and  
 the first and second transparent conductive layers.
- 2.** The device of claim 1, wherein the sealant covers the  
 gate lines.
- 3.** The device of claim 1, wherein the passivation layer is  
 formed of an organic insulating layer.
- 4.** The device of claim 3, wherein the organic insulating  
 layer includes one of BCB and photo-acrylate.
- 5.** The device of claim 1, further comprising a conductive  
 layer on the second substrate.
- 6.** The device of claim 5, wherein the sealant is formed to  
 surround the conductive layer.
- 7.** The device of claim 5, wherein the conductive layer  
 includes silver (Ag).
- 8.** The device of claim 1, wherein the first transparent  
 conductive layer is a pixel electrode.
- 9.** The device of claim 1, wherein the second transparent  
 conductive layer is a common electrode.
- 10.** The device of claim 1, wherein the first and second  
 transparent conductive layers are formed of indium tin oxide  
 (ITO).
- 11.** The device of claim 1, wherein the black matrix is  
 formed at least about 2.0 mm inside an edge of the second  
 substrate.
- 12.** The device of claim 1, wherein the first transparent  
 conductive layer is contacted with a portion of the gate lines.
- 13.** The device of claim 1, wherein the sealant is formed  
 on one of the first and second substrates.
- 14.** The device of claim 1, wherein the sealant has  
 rounded corners.
- 15.** The device of claim 1, wherein the sealant includes  
 one of dumbbell, rectangle, doughnut, and polygonal shapes.
- 16.** A method of forming a liquid crystal display device,  
 comprising:  
 forming first and second substrates;  
 forming a plurality of gate lines on the first substrate;  
 forming a passivation layer on the gate lines;  
 forming a first transparent conductive layer on the passi-  
 vation layer;  
 forming a black matrix at an inner surface of the second  
 substrate;  
 forming a second transparent conductive layer on the  
 black matrix; and  
 forming a sealant covering at least portions of the black  
 matrix and the first and second transparent layers.
- 17.** The method of claim 16, wherein the sealant covers  
 the gate lines.
- 18.** The method of claim 16, wherein the passivation layer  
 is formed of an organic insulating layer.
- 19.** The method of claim 18, wherein the organic insu-  
 lating layer includes one of BCB and photo-acrylate.
- 20.** The method of claim 16, further comprising forming  
 a conductive layer on the second substrate.
- 21.** The method of claim 20, wherein the sealant is formed  
 to surround the conductive layer.
- 22.** The method of claim 20, wherein the conductive layer  
 includes silver (Ag).
- 23.** The method of claim 16, wherein the first transparent  
 conductive layer is a pixel electrode.
- 24.** The method of claim 16, wherein the second trans-  
 parent conductive layer is a common electrode.
- 25.** The method of claim 16, wherein the first and second  
 transparent conductive layers are formed of indium tin oxide  
 (ITO).
- 26.** The method of claim 16, wherein the black matrix is  
 formed at least about 2.0 mm inside an edge of the second  
 substrate.
- 27.** The method of claim 16, wherein the first transparent  
 conductive layer is contacted with a portion of the gate lines.
- 28.** The method of claim 16, wherein the sealant is formed  
 on one of the first and second substrates.
- 29.** The method of claim 16, wherein the sealant has  
 rounded corners.
- 30.** The method of claim 16, wherein the sealant includes  
 one of dumbbell, rectangle, doughnut, and polygonal shapes.

\* \* \* \* \*

专利名称(译)	具有防止电解腐蚀的密封图案的液晶显示装置及其制造方法		
公开(公告)号	<a href="#">US20030112387A1</a>	公开(公告)日	2003-06-19
申请号	US10/294777	申请日	2002-11-15
[标]申请(专利权)人(译)	LIM JOO SOO		
申请(专利权)人(译)	LIM JOO SOO		
当前申请(专利权)人(译)	LIM JOO SOO		
[标]发明人	LIM JOO SOO		
发明人	LIM, JOO SOO		
IPC分类号	G02F1/1333 G02F1/1335 G02F1/1339		
CPC分类号	G02F1/133345 G02F2201/123 G02F1/1339 G02F1/133512		
优先权	1020010088558 2001-12-19 KR		
其他公开文献	US7433010		
外部链接	<a href="#">Espacenet</a> <a href="#">USPTO</a>		

摘要(译)

本发明公开了一种具有防止电解腐蚀的密封图案的液晶显示装置及其制造方法。液晶显示装置包括第一和第二基板，多条栅极线，栅极线上的钝化层，钝化层上的第一透明导电层，第二基板内表面上的黑矩阵，第二透明黑矩阵上的导电层，以及覆盖黑矩阵和第一和第二透明导电层的至少一部分的密封剂。

