



US006943858B2

(12) **United States Patent**  
**Lyu et al.**

(10) **Patent No.:** **US 6,943,858 B2**  
(45) **Date of Patent:** **Sep. 13, 2005**

(54) **LIQUID CRYSTAL DISPLAY DEVICES HAVING WIDE VIEWING ANGLE AND IMPROVED CONTRAST RATIO** 4,068,925 A 1/1978 Tani et al. .... 349/130  
(Continued)

(75) Inventors: **Jae-Jin Lyu**, Kyungki-do (KR); **Hea-Ri Lee**, Seoul (KR); **Kyeong-Hyeon Kim**, Kyungki-do (KR); **Jian-Min Chen**, Kyungki-do (KR)  
FOREIGN PATENT DOCUMENTS  
JP 58116518 A 7/1983  
JP 2-19833 1/1990 ..... G02F/1/1335

(73) Assignee: **Samsung Electronics Co., Ltd.**, Suwon (KR)  
OTHER PUBLICATIONS

(\* ) Notice: Subject to any disclaimer, the term of this patent is extended or adjusted under 35 U.S.C. 154(b) by 0 days.  
Hashimoto, T. et al. TN-LCD with Quartered Subpixels Using Polarized UV-Light-Irradiated Polymer Orientation Films, *SID 95 Digest*, pp. 877-880.

(21) Appl. No.: **10/655,516**  
(22) Filed: **Sep. 4, 2003**  
*Primary Examiner*—Dung T. Nguyen  
(74) *Attorney, Agent, or Firm*—McGuireWoods LLP

(65) **Prior Publication Data**  
US 2004/0046916 A1 Mar. 11, 2004  
(57) **ABSTRACT**

**Related U.S. Application Data**

(62) Division of application No. 10/114,718, filed on Apr. 1, 2002, now Pat. No. 6,646,701, which is a division of application No. 09/087,628, filed on May 29, 1998, now abandoned.

(30) **Foreign Application Priority Data**

May 2, 1997 (KR) ..... 97-21709  
Jun. 27, 1997 (KR) ..... 97-28480

(51) **Int. Cl.**<sup>7</sup> ..... **G02F 1/1335**; G02F 1/1337; C09K 19/02

(52) **U.S. Cl.** ..... **349/119**; 349/121; 349/130; 349/178

(58) **Field of Search** ..... 349/117-119, 121, 349/130, 178

(56) **References Cited**

**U.S. PATENT DOCUMENTS**

4,054,368 A 10/1977 Krueger et al. .... 349/117

**15 Claims, 27 Drawing Sheets**

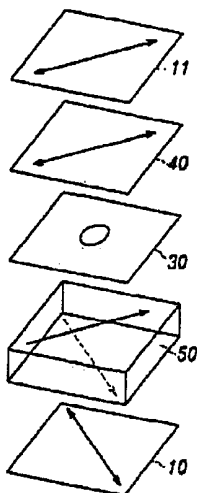

U.S. PATENT DOCUMENTS

4,490,015 A	12/1984	Kawarada et al. ....	349/178	5,570,214 A	10/1996	Abileah et al. ....	349/117
5,039,185 A	8/1991	Uchida et al. ....	349/178	5,598,285 A	1/1997	Kondo et al. ....	349/39
5,298,199 A	3/1994	Hirose et al. ....	349/117	5,757,455 A	5/1998	Sugiyama et al. ....	349/129
5,477,358 A	12/1995	Rosenblatt et al. ....	359/77	5,770,826 A	6/1998	Chaudhari et al. ....	204/157.15
5,504,603 A	4/1996	Winker et al. ....	349/117	6,141,075 A	10/2000	Ohmuro et al. ....	349/130
5,519,523 A	5/1996	Madokoro et al. ....	349/117	6,646,701 B2 *	11/2003	Lyu et al. ....	349/119
5,550,661 A	8/1996	Clark et al. ....	349/117	2002/0149733 A1	10/2002	Lyu et al. ....	349/155
5,557,434 A	9/1996	Winker et al. ....	349/117				

\* cited by examiner

FIG.1A

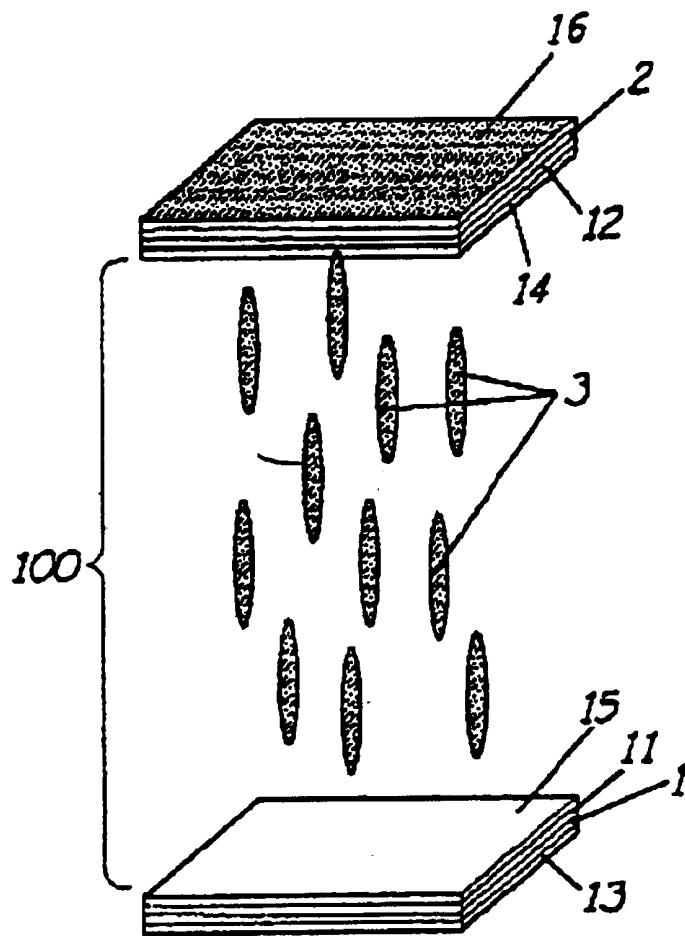

FIG.1B

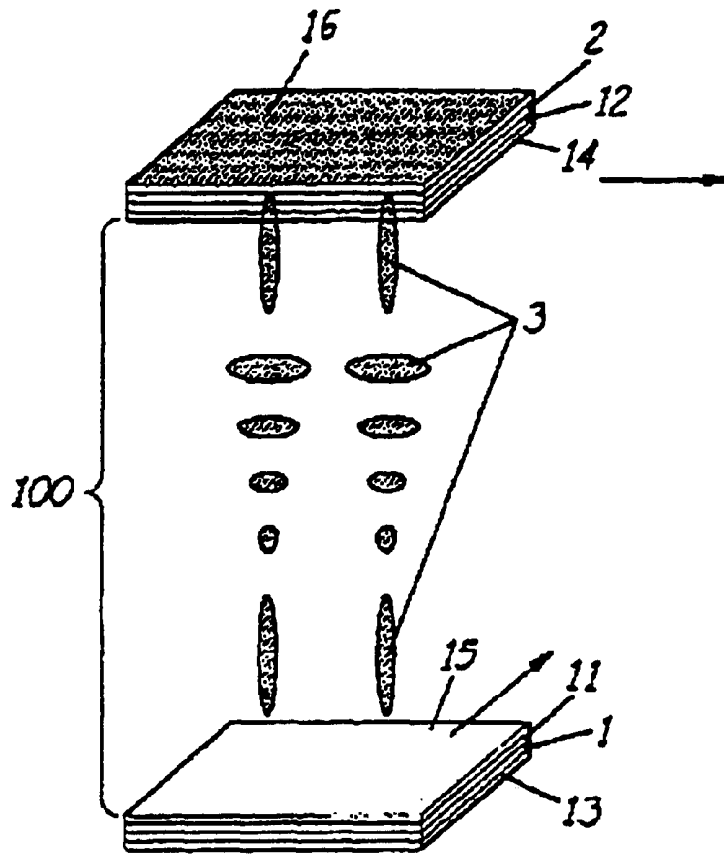

FIG.2

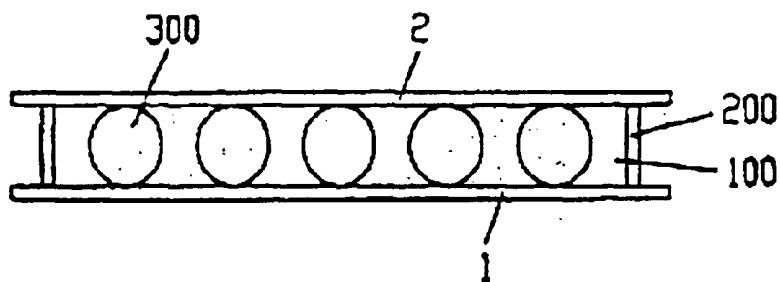

FIG.3

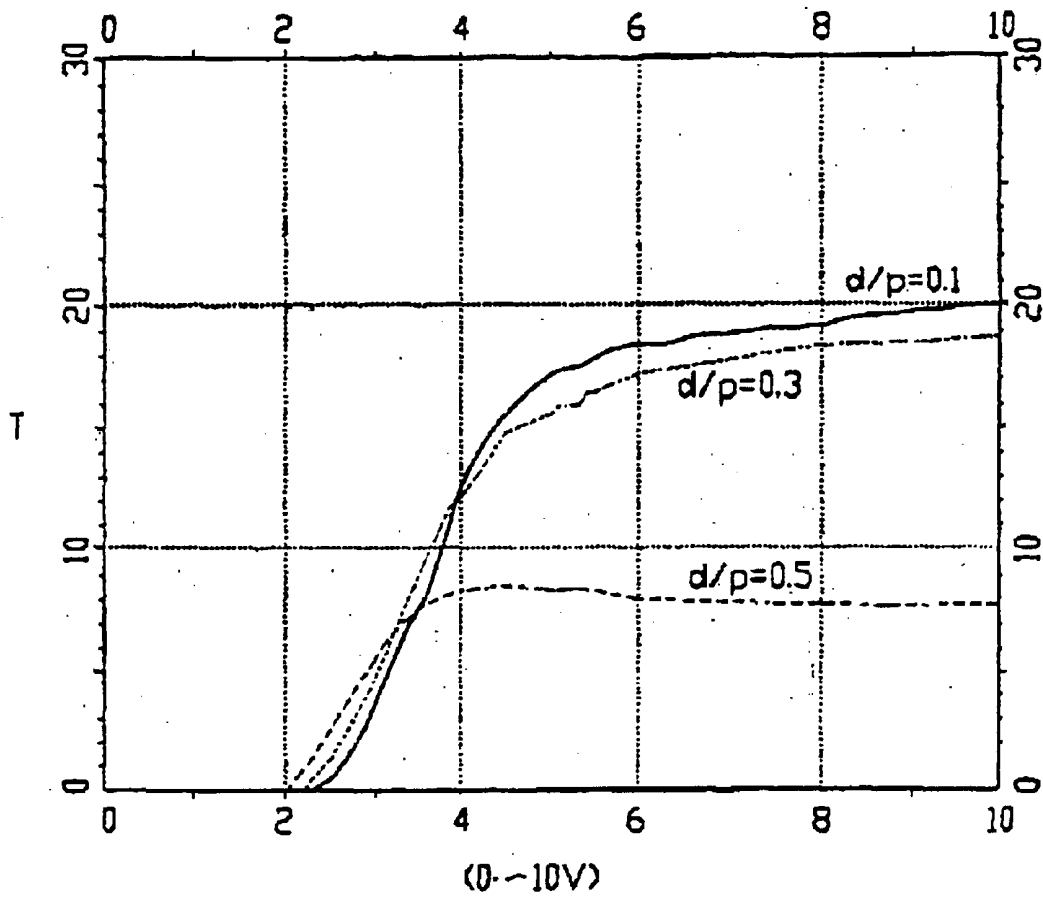

FIG. 4A

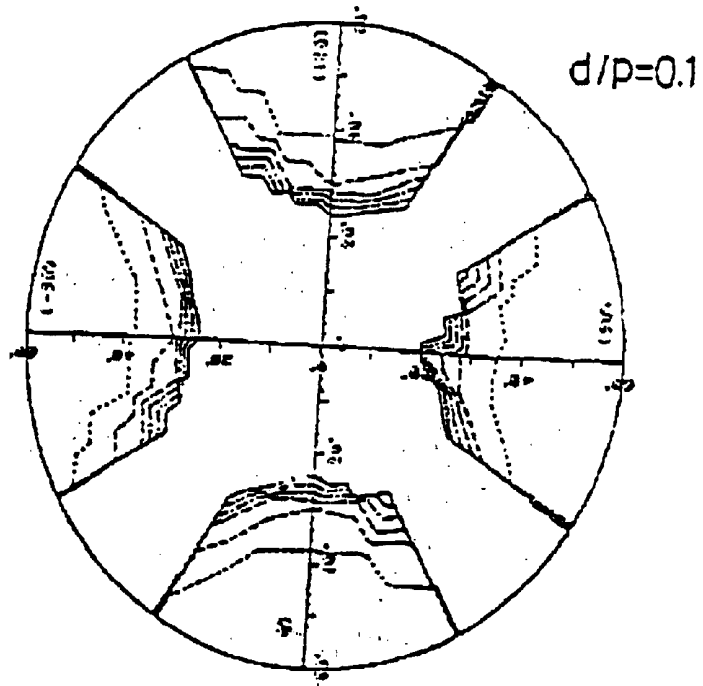

FIG. 4B

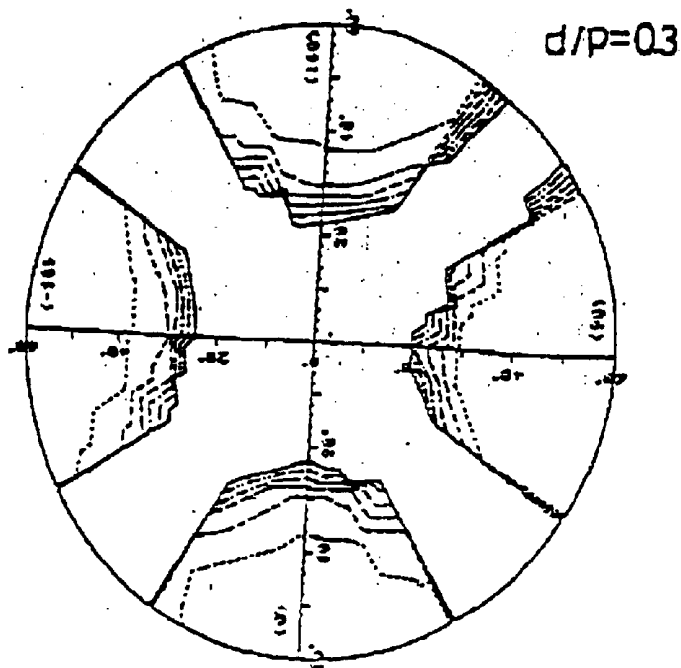

FIG. 4C

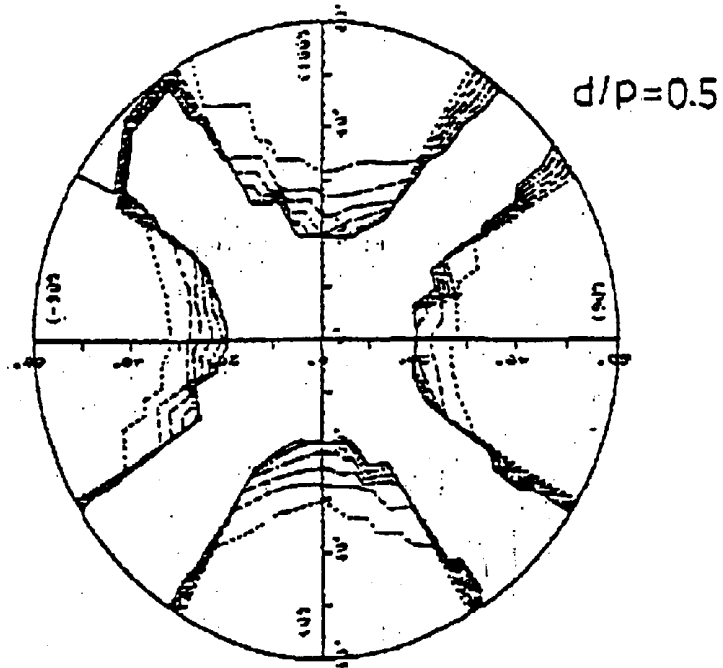

FIG. 6A

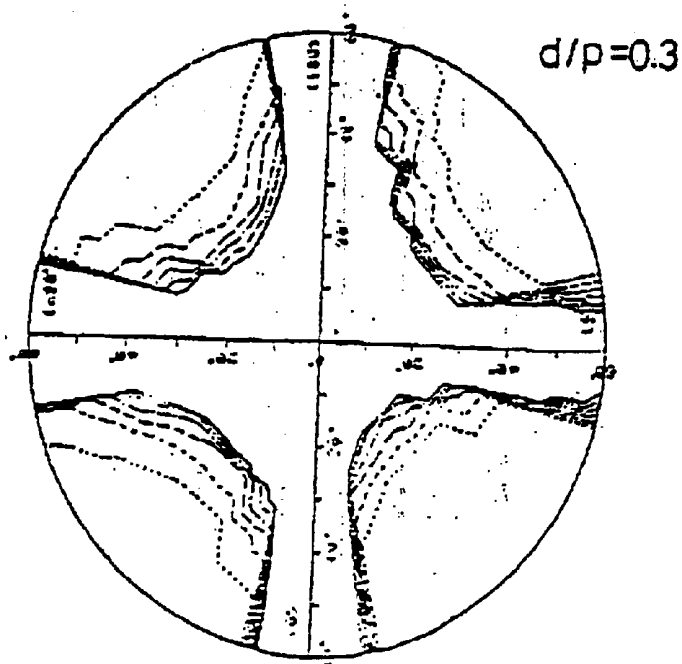

FIG. 5

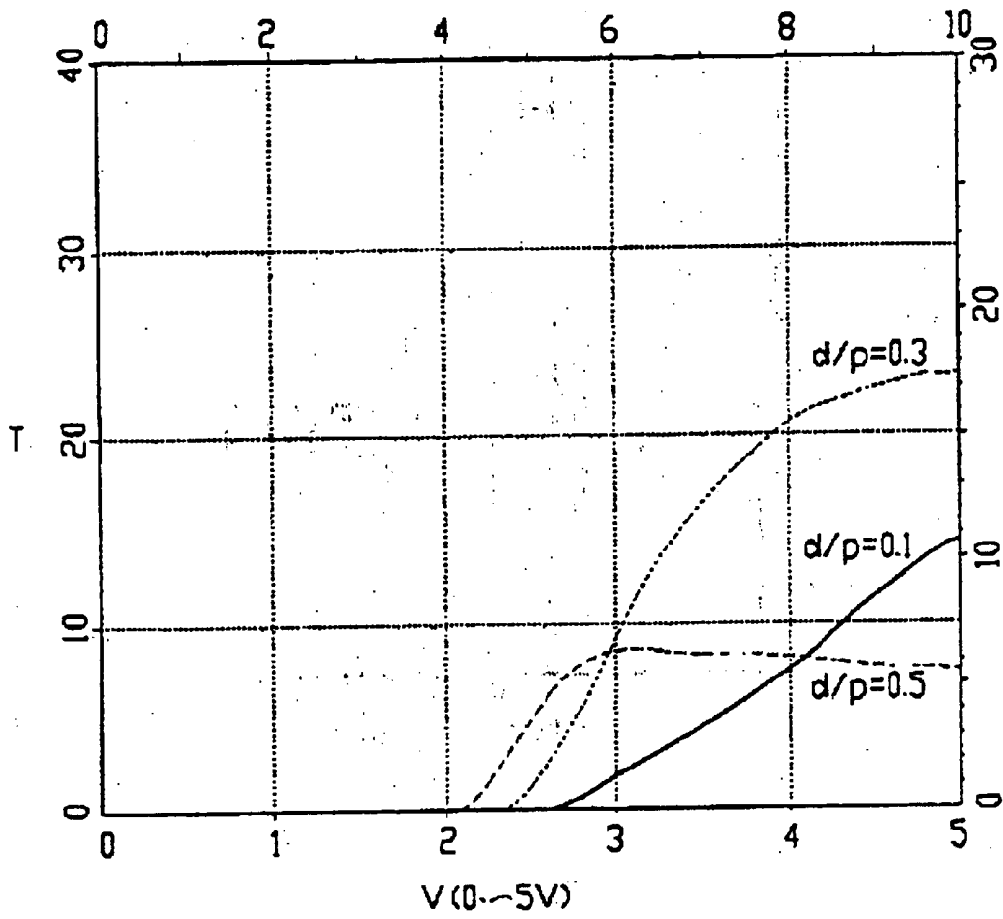

FIG. 6B

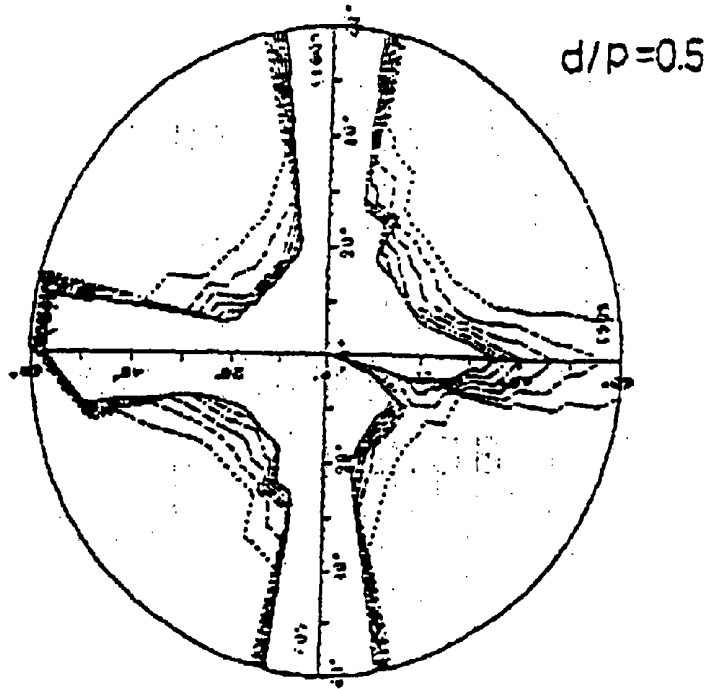

FIG. 8A

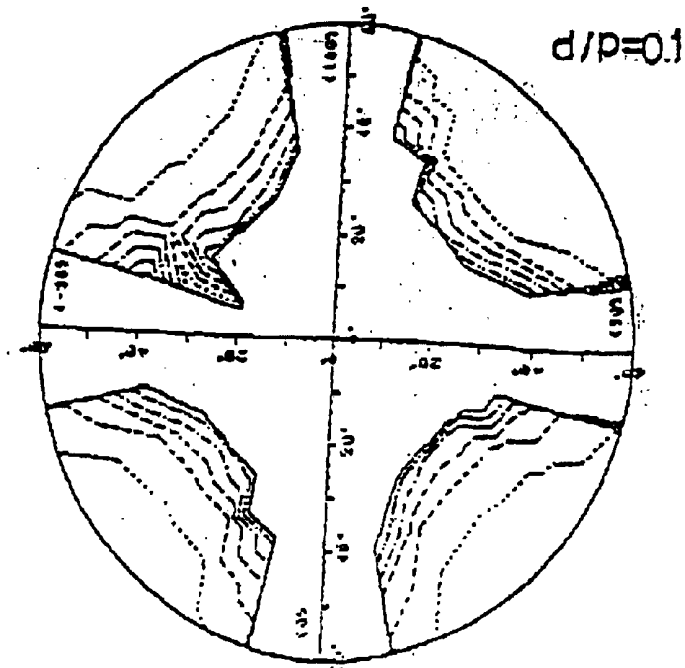

FIG. 7

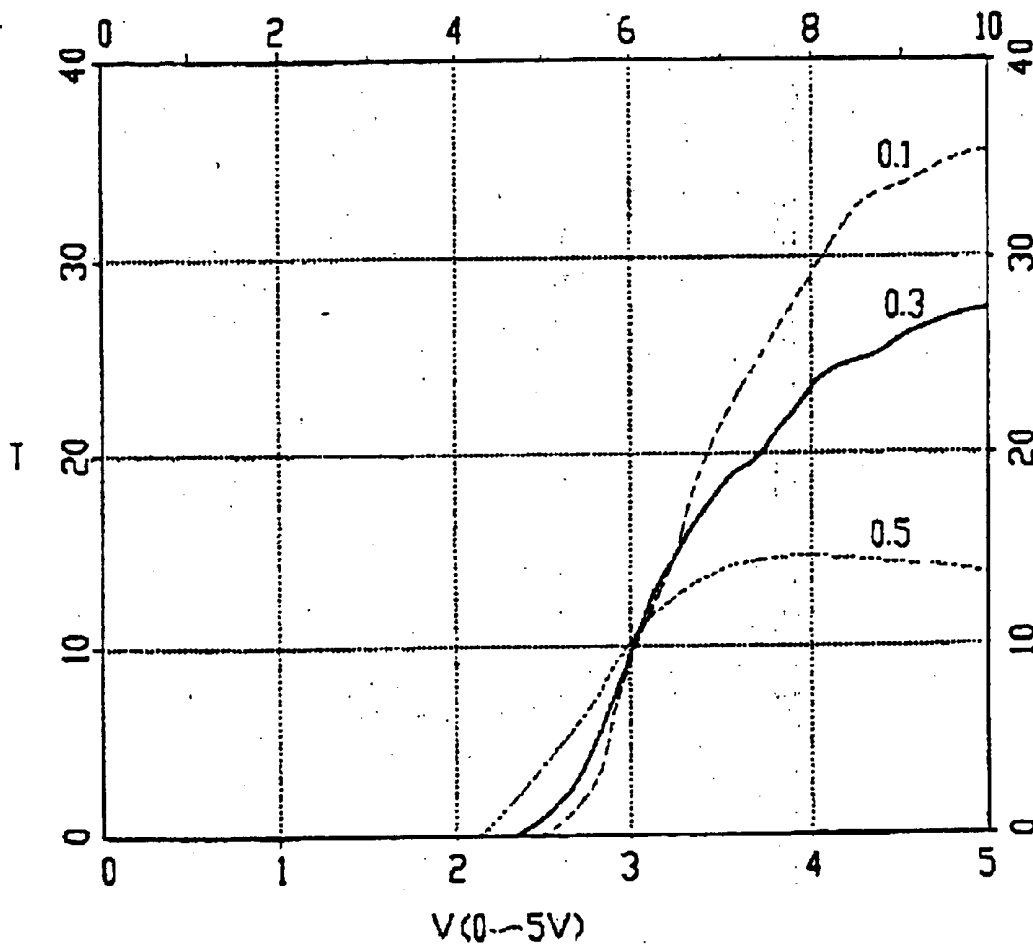

FIG. 8B

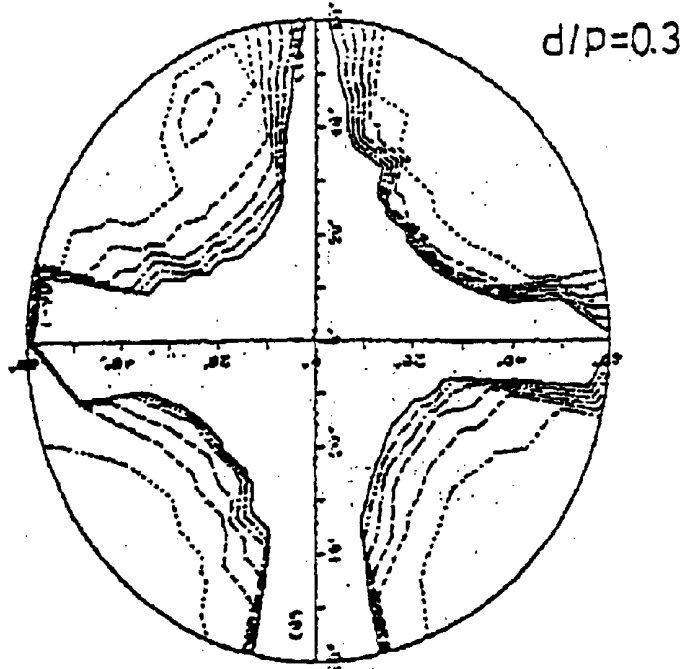

FIG. 8C

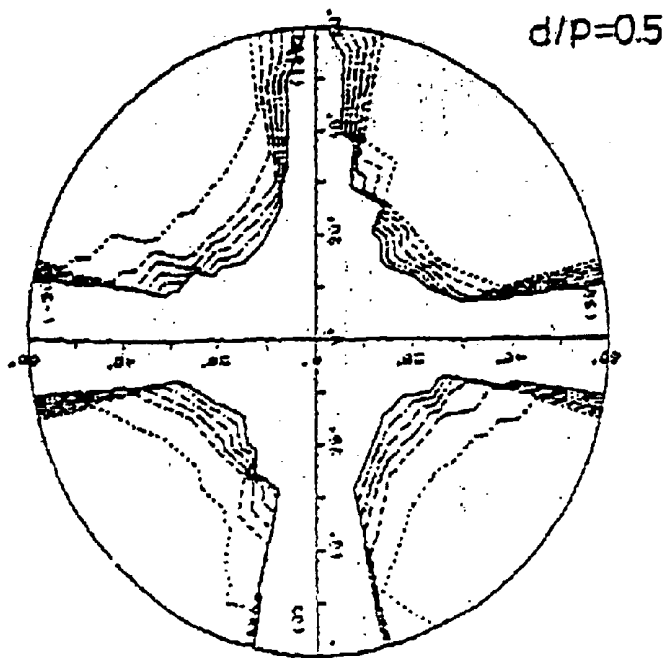

FIG. 9

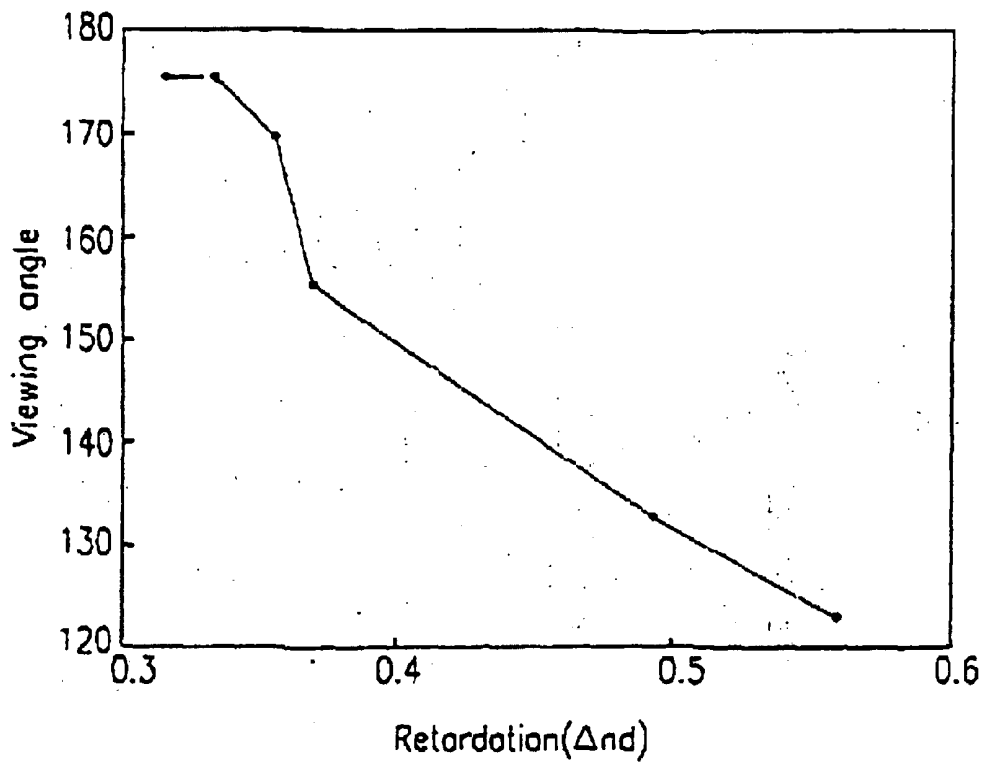

FIG.10

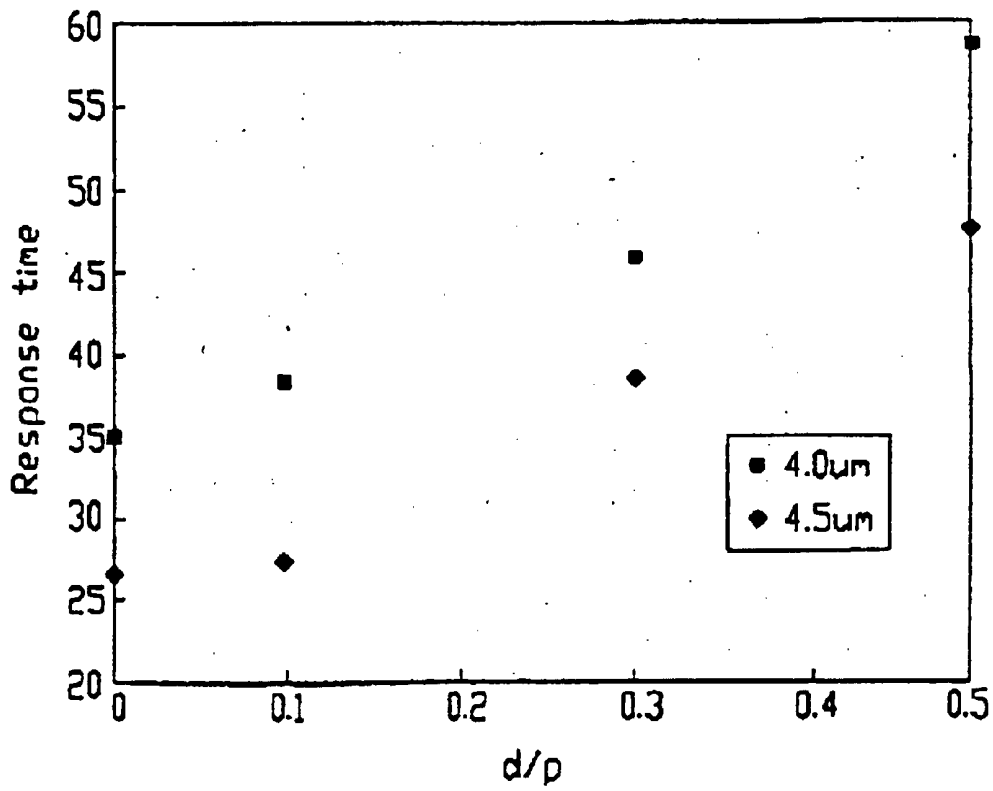

FIG. 11A

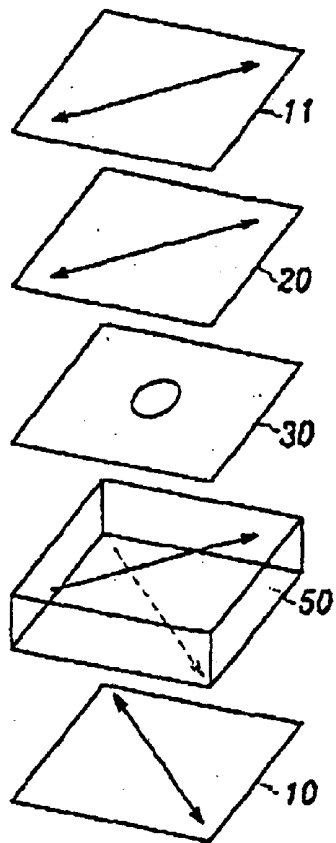

FIG. 11B

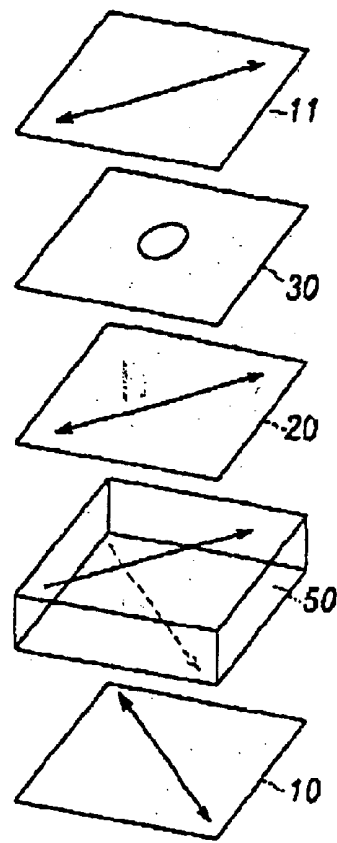

FIG. 11C

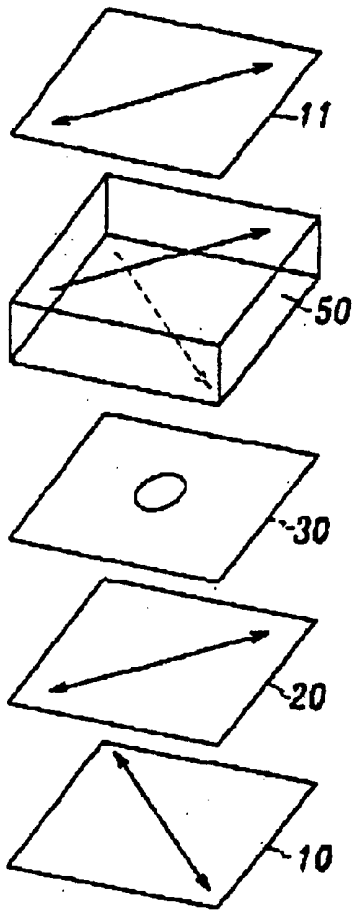

FIG. 11D

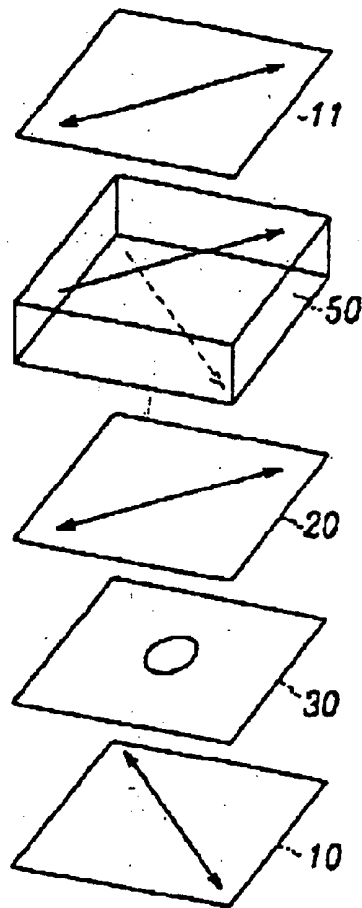

FIG. 12A

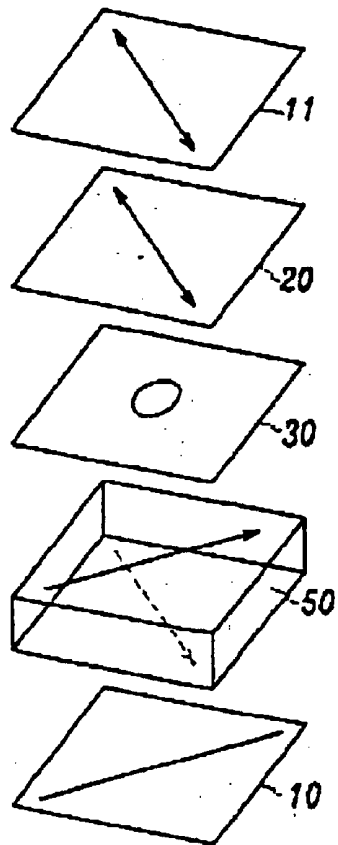

FIG. 12B

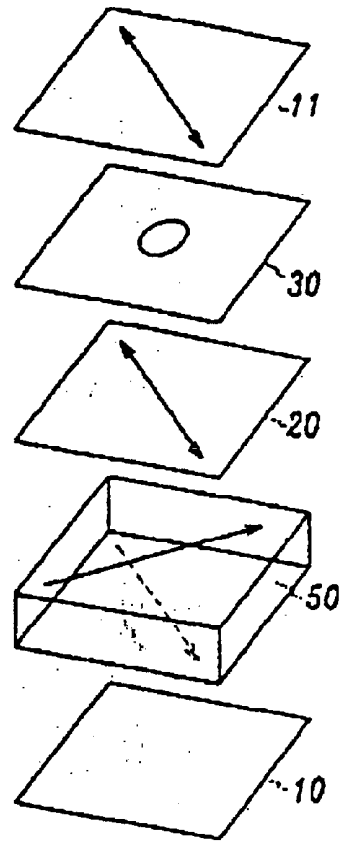

FIG. 12C

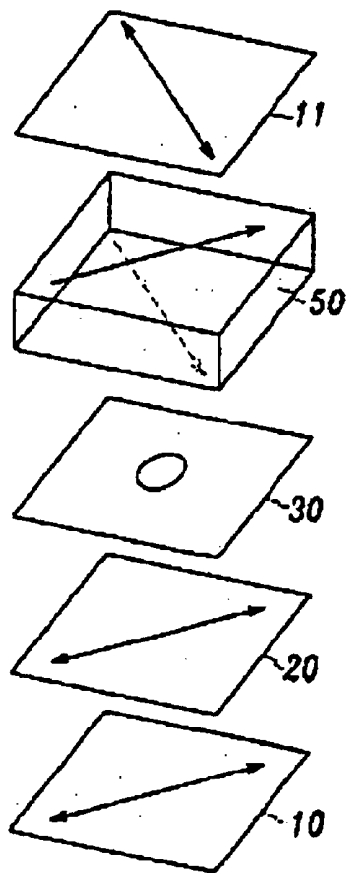

FIG. 12D

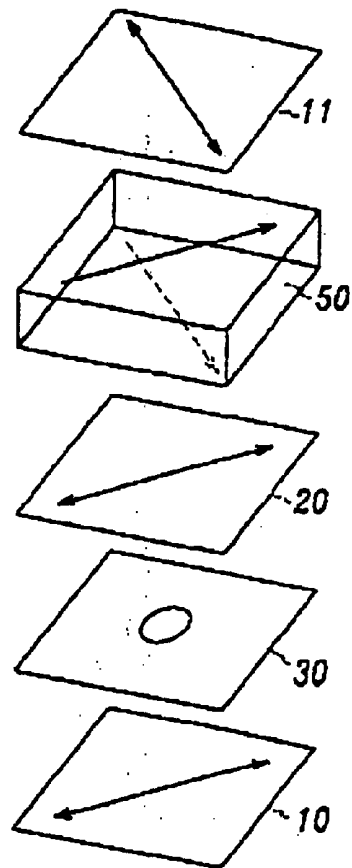

FIG. 13

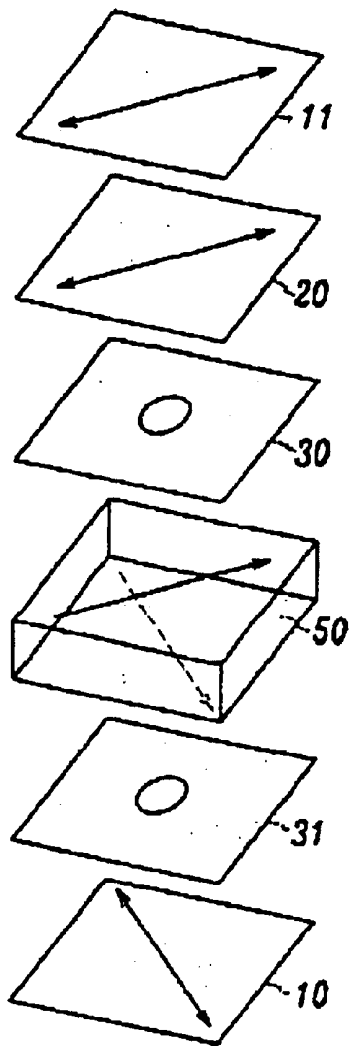

FIG. 14

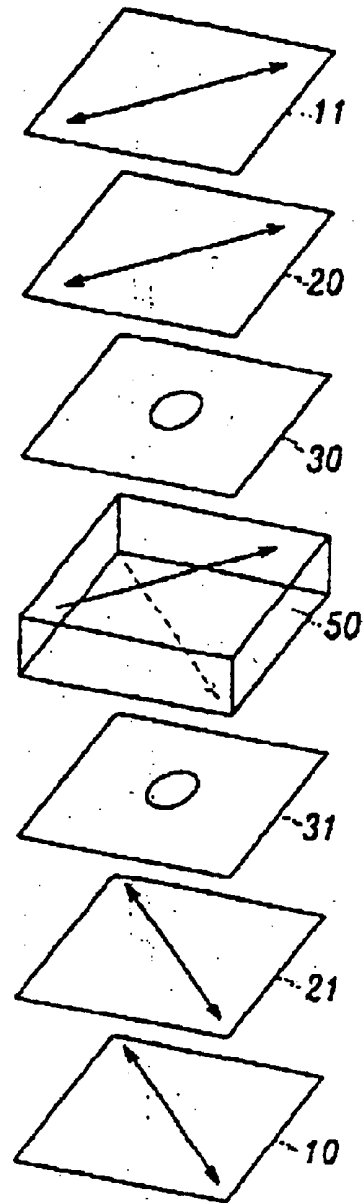

FIG. 15

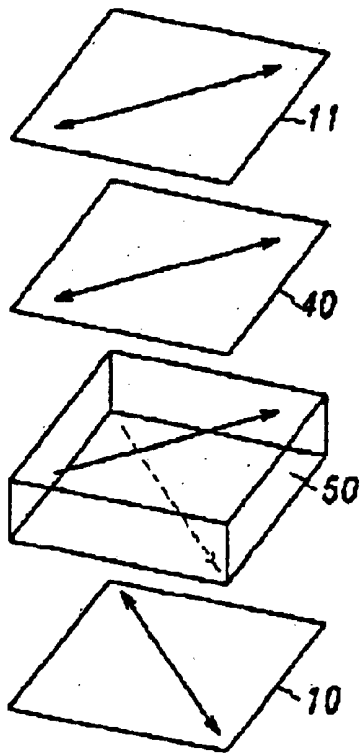

FIG. 16

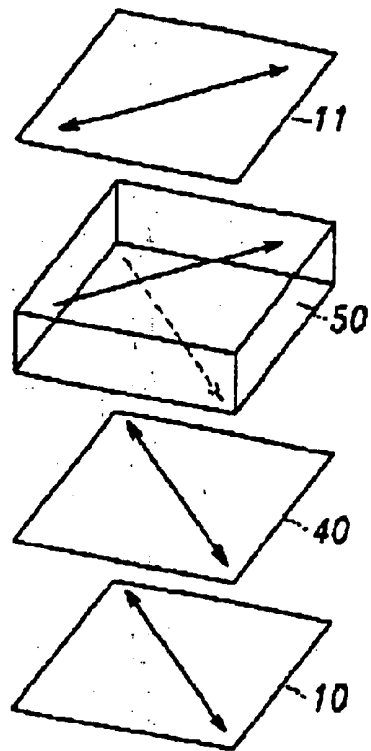

FIG. 17

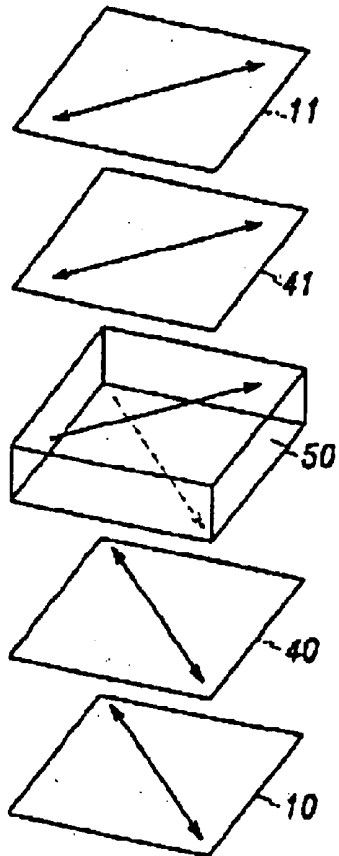

FIG. 18

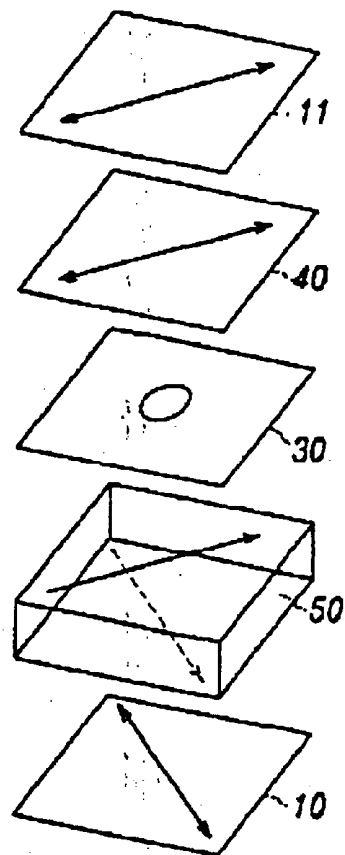

FIG. 19

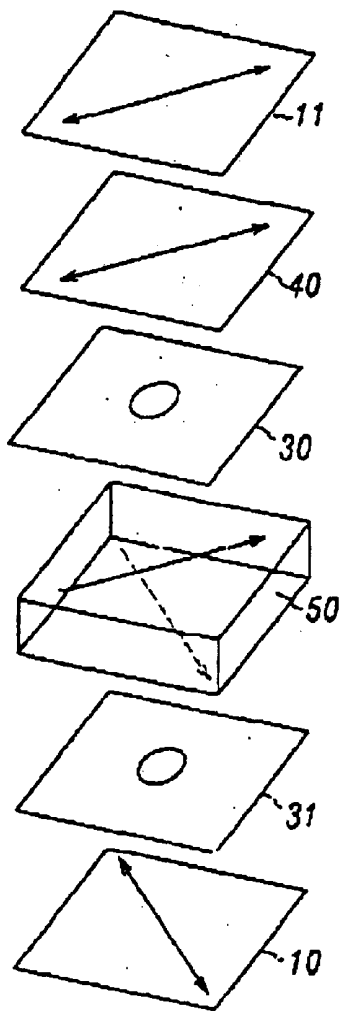

FIG. 20

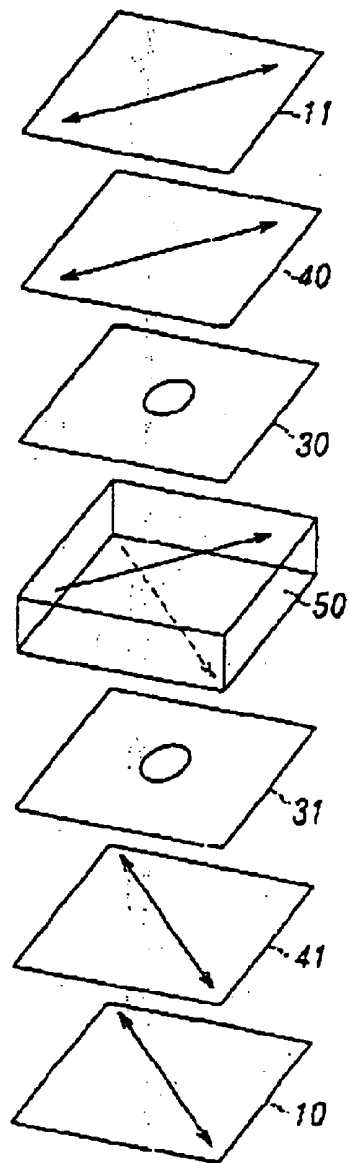

FIG. 21

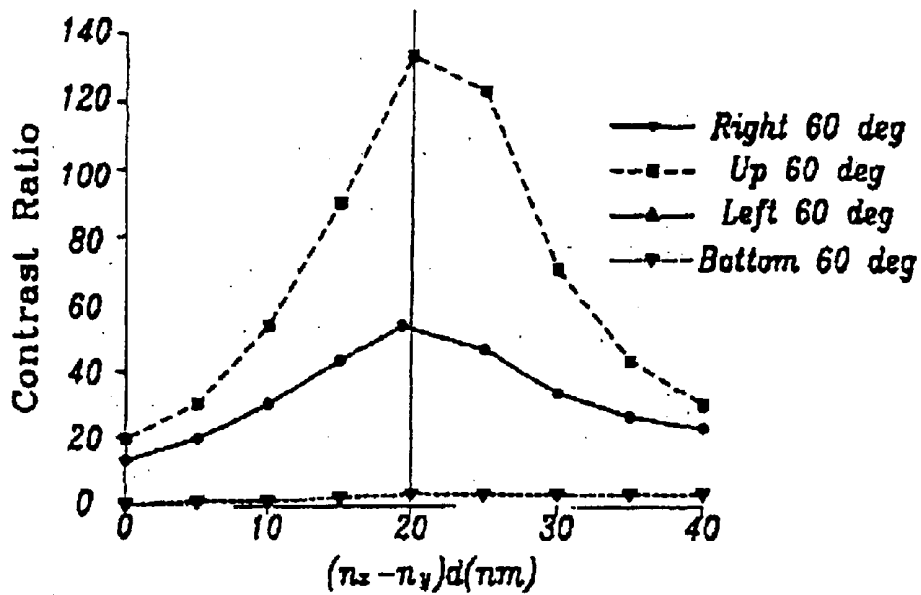

FIG. 22

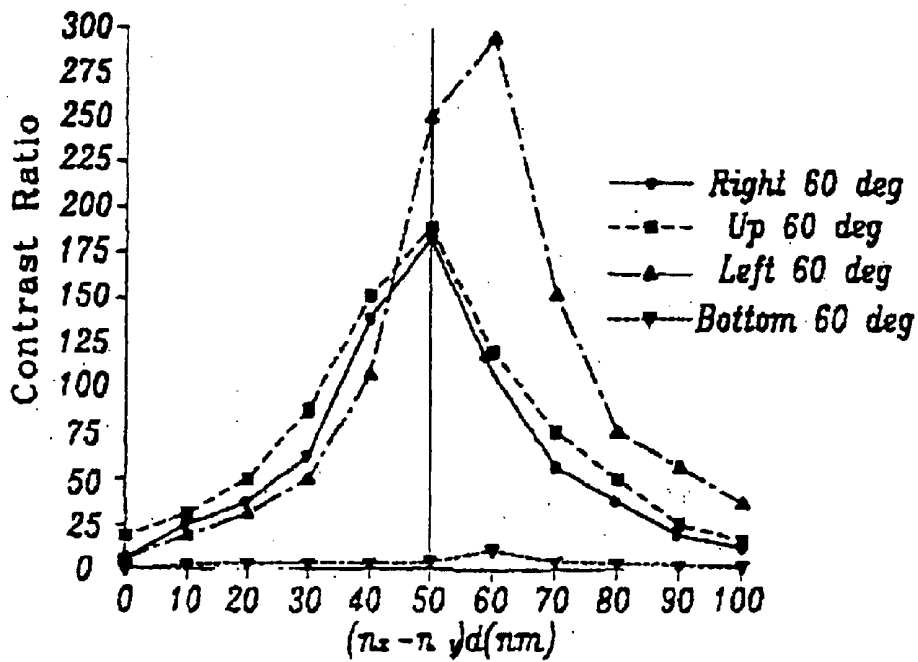

FIG.23

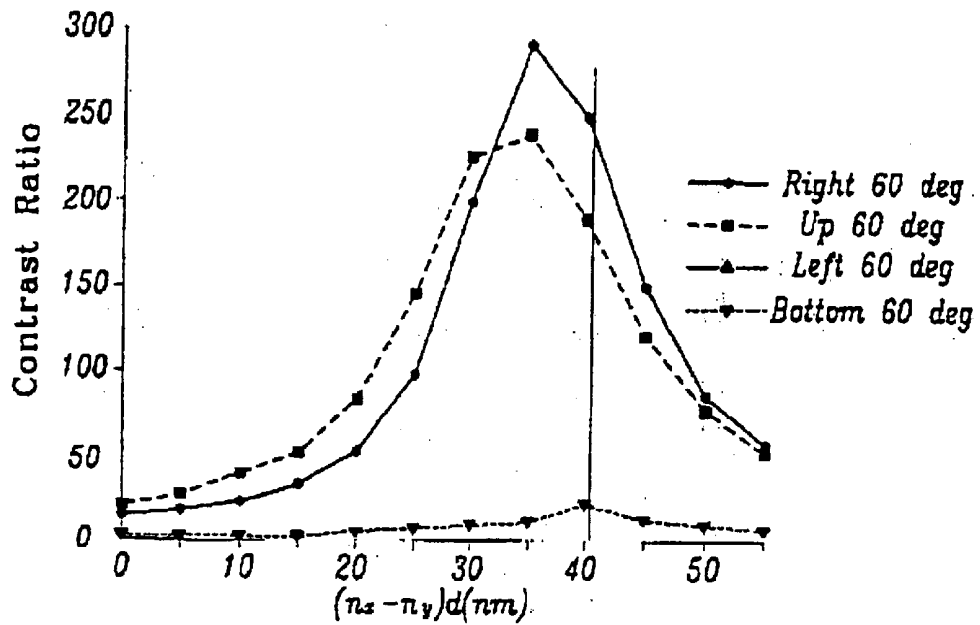

FIG.28A

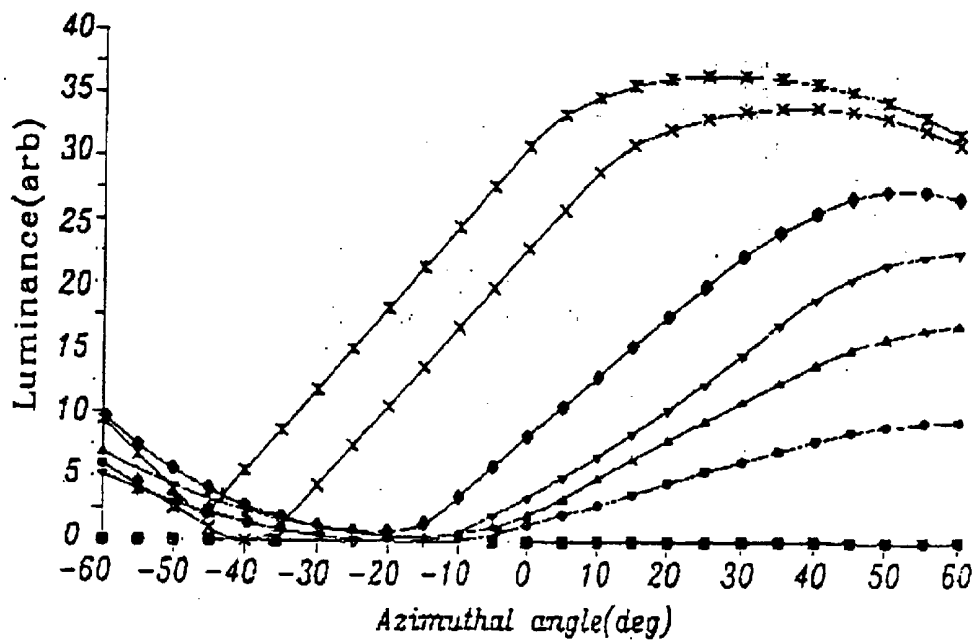

FIG. 24

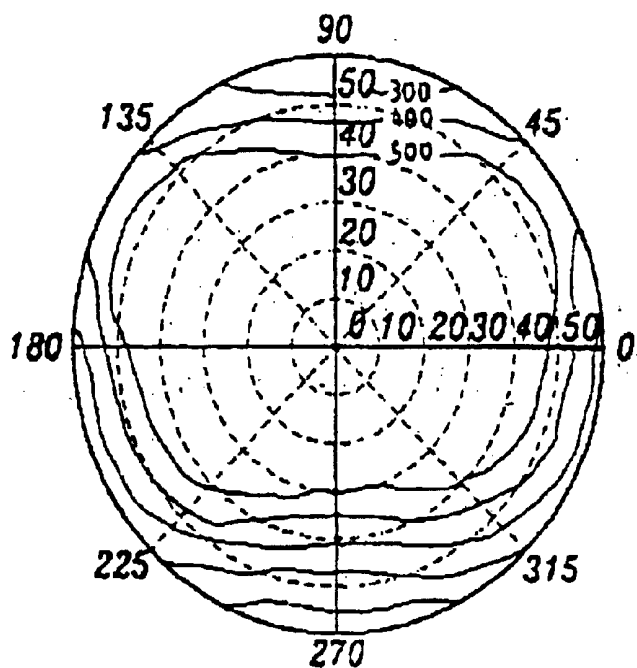

FIG. 25

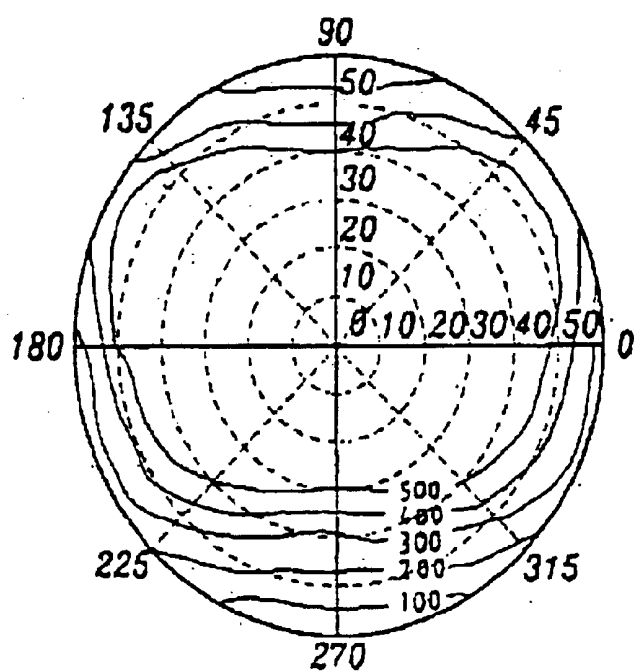

FIG. 26

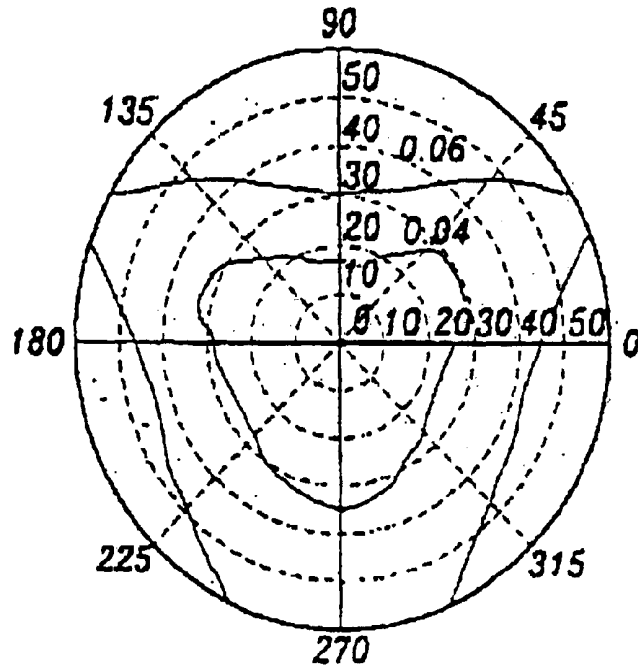

FIG. 27

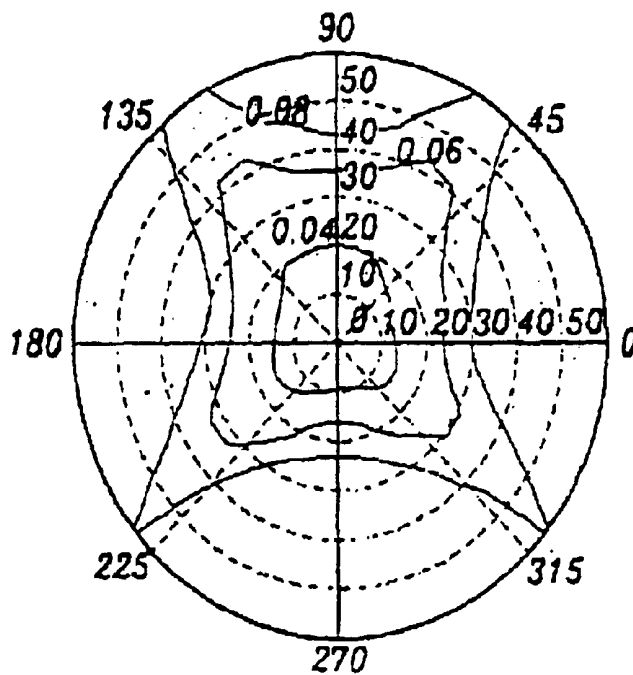

FIG.28B

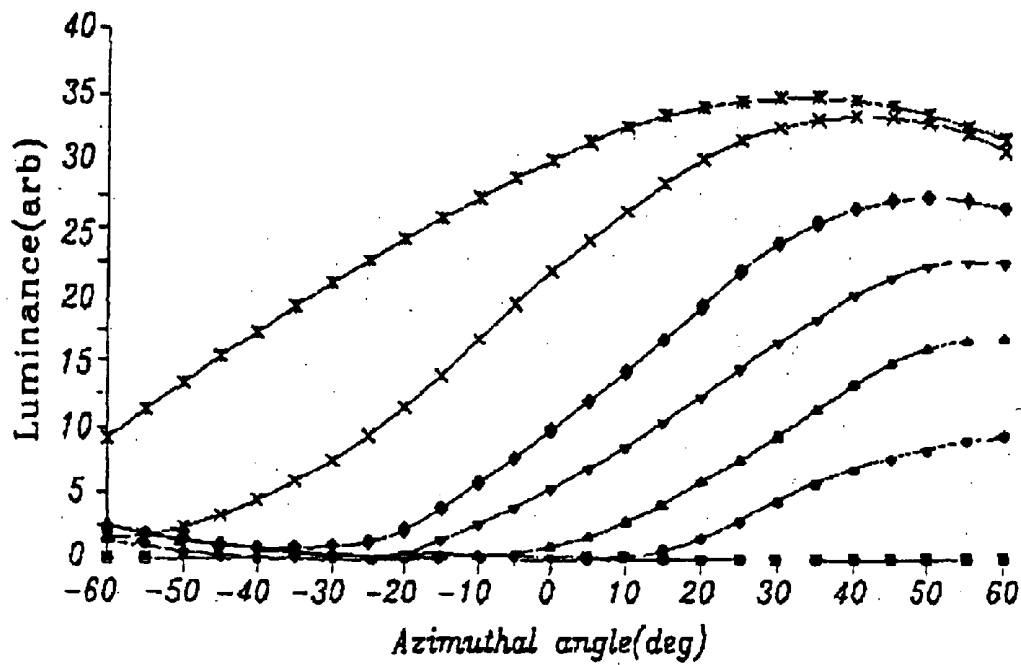

FIG.28C

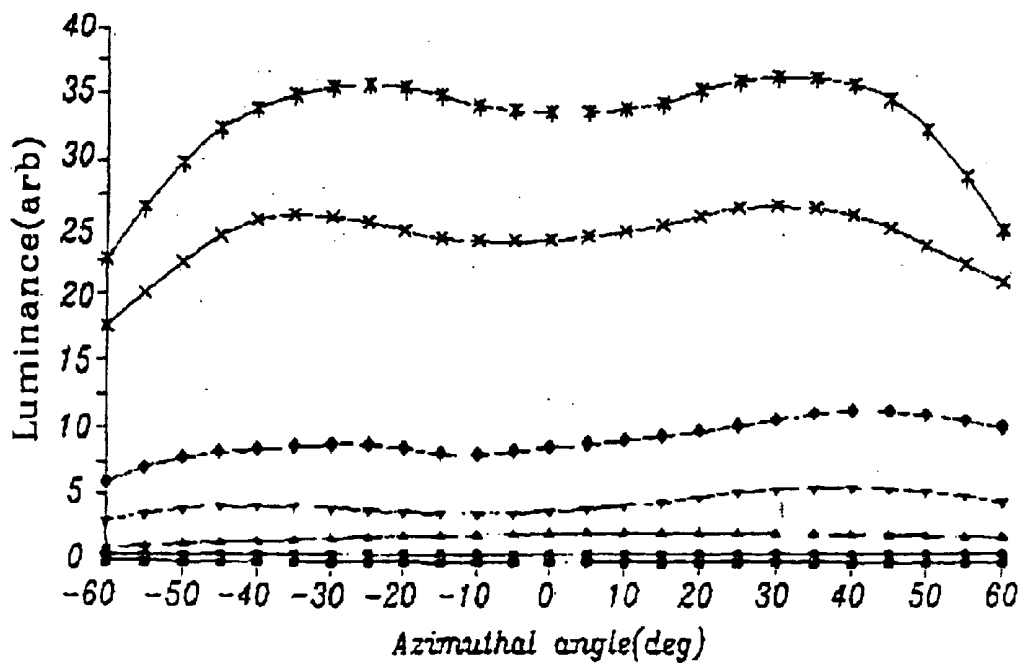

FIG. 29A

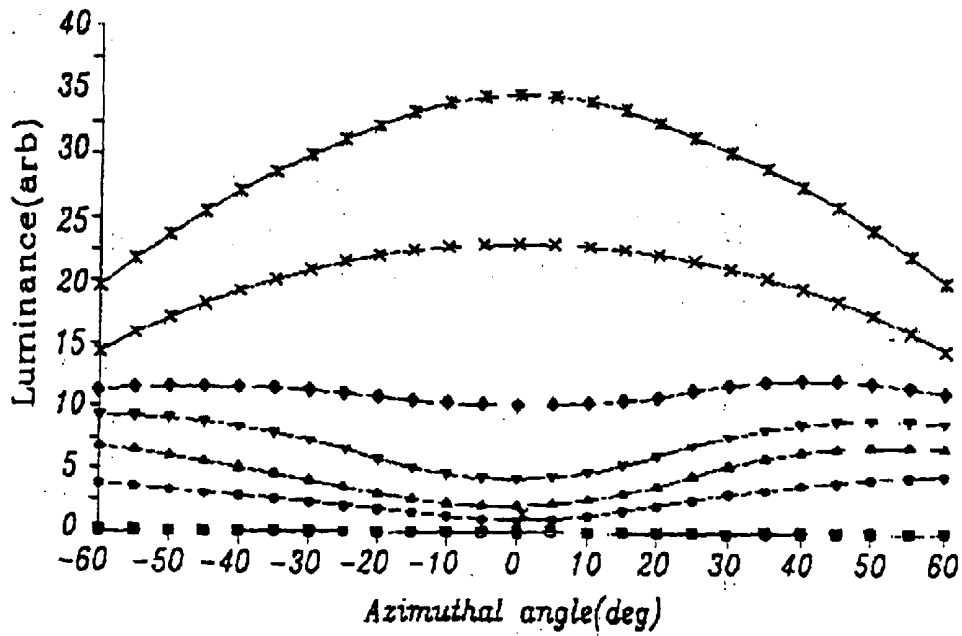

FIG. 29B

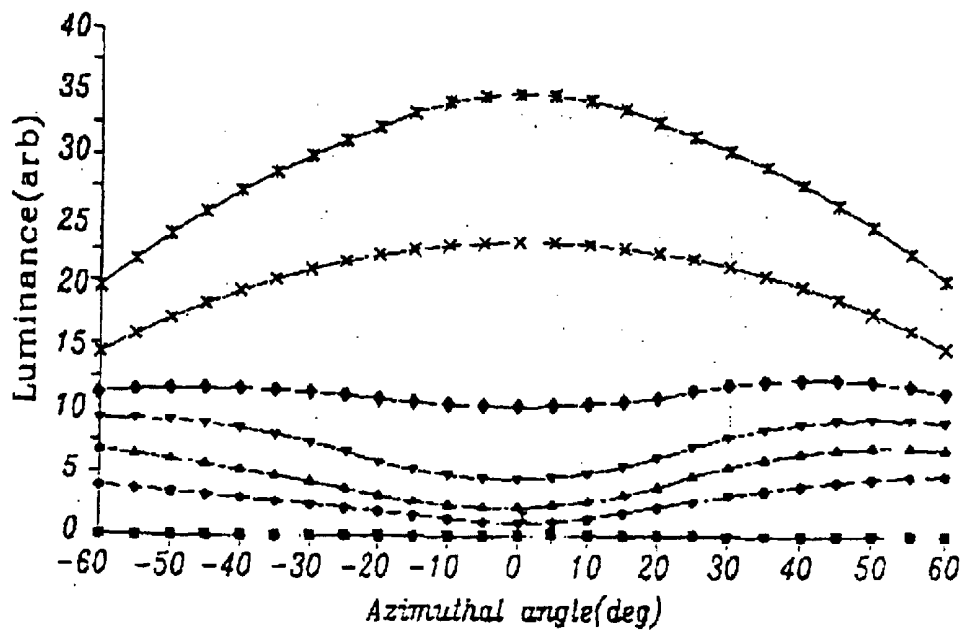

FIG.29C

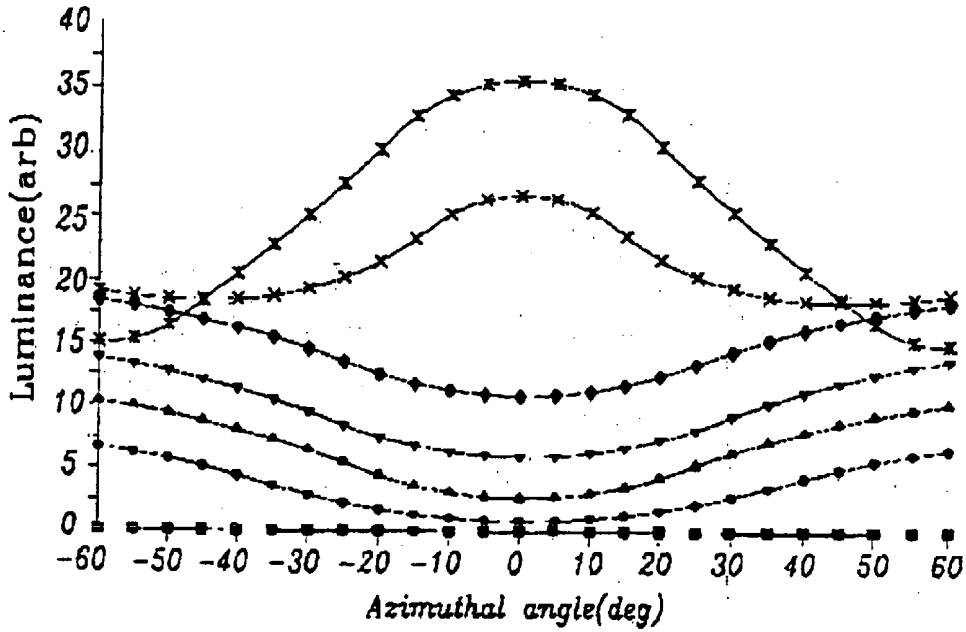

FIG.29D

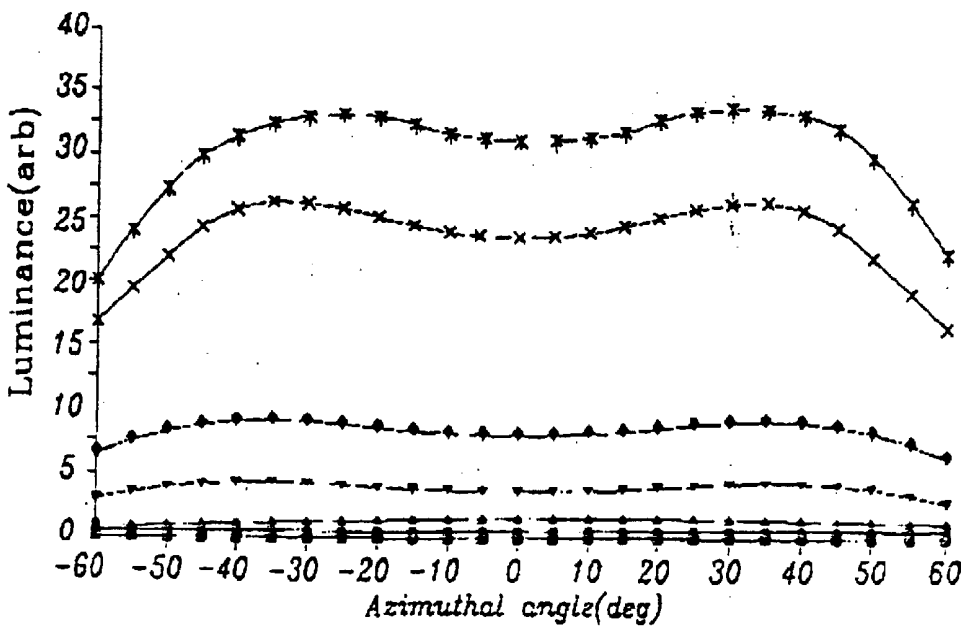

FIG. 30

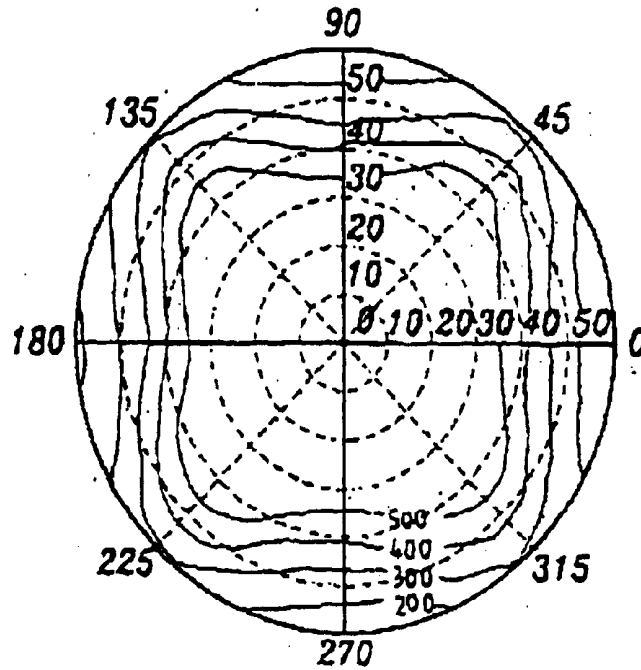
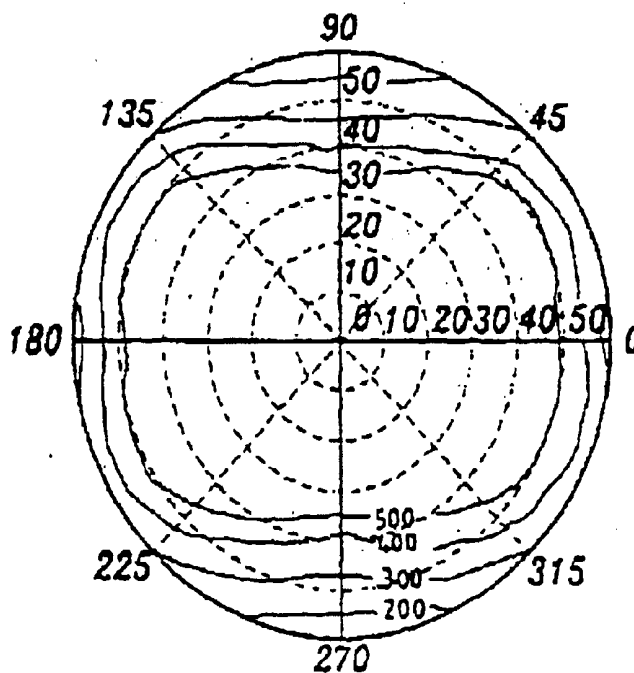

FIG. 31



# LIQUID CRYSTAL DISPLAY DEVICES HAVING WIDE VIEWING ANGLE AND IMPROVED CONTRAST RATIO

## RELATED APPLICATIONS

This application is a divisional of U.S. application Ser. No. 10/114,718, filed Apr. 1, 2002 now U.S. Pat. No. 6,646,701, which is a divisional of U.S. application Ser. No. 09/087,628, filed May 29, 1998 (now abandoned), the disclosures of which are hereby incorporated herein by reference.

## BACKGROUND OF THE INVENTION

### 1. Field of the Invention

The present invention relates to liquid crystal displays using vertical alignment and compensation films.

### 2. Description of the Related Art

A liquid crystal display has two substrates opposite each other and a liquid crystal layer interposed between the substrates. If the electric field is applied to the liquid crystal layer, the liquid crystal molecules changes their orientations to control the transmittance of the incident light.

A twisted nematic (TN) liquid crystal display includes a couple of transparent substrates having transparent electrodes thereon, a liquid crystal layer interposed between the substrates, and a couple of polarizers which are attached to the outer surfaces of the substrates. In off state, i.e., in absence of the electric field, the molecular axes of the liquid crystal molecules are aligned parallel to the substrates and twisted spirally by a constant pitch from one substrate to the other substrate, and the director of the liquid crystal layer varies continuously.

However, the contrast ratio of the conventional TN mode liquid crystal display, especially in normally black mode, may not be so high because the incident light is not fully blocked in absence of the electric field.

To solve this problem a vertically aligned twisted nematic (VATN) mode liquid crystal display is proposed in the U.S. Pat. No. 5,477,358, "CHIRAL NEMATIC LIQUID CRYSTAL DISPLAY WITH HOMEOTROPIC ALIGNMENT AND NEGATIVE DIELECTRIC ANISOTROPY", whose patentee is Case Western Reserve University and in "Euro-display '93", pp. 158-159 by Takahashi et al.

On the contrary to the TN mode, the alignment of the liquid crystal molecules of the VATN mode liquid crystal display in off state is similar to that of the TN mode in on state, that is, the liquid crystal molecules align perpendicular to the substrates. In the on state, the molecular axes of the liquid crystal molecules are aligned parallel to the substrates and twisted spirally by a constant pitch from one substrate to the other substrate, and the director of the liquid crystal layer varies continuously.

In case of VATN mode liquid crystal display in normally black mode, sufficient darkness in off state because the molecular axes of the liquid crystal molecules are aligned vertically to the substrate when the electric field is applied.

The display characteristics of VATN may become better by optimizing the parameters such as the ratio  $d/p$  of the cell gap  $d$  to the pitch  $p$  of the liquid crystal layer, the difference of refractive indices  $\Delta n$  between in both directions and the retardation value  $\Delta n \cdot d$ .

In the mean time, because of the refractive anisotropy of the liquid crystal material the retardation value  $\Delta n \cdot d$  changes as the viewing direction, thereby causing the dif-

ference of the intensity and the characteristics of light. Therefore, TN displays have the change in contrast ratio, color shift, gray inversion, etc. according to the viewing angle.

TN LCDs with compensation film are developed to compensate the difference of retardation in liquid crystal layer. However, the film compensated TN LCDs still have problems such as in harmony of the display characteristics and gray inversion.

## SUMMARY OF THE INVENTION

It is therefore an object of the present invention to provide optimized cell parameters such as  $d/p$ ,  $\Delta n$  and  $\Delta n \cdot d$  to improve the optical characteristics fo LCDs.

It is another object of the present invention to widen the viewing angle of liquid crystal displays.

It is another object of the present invention to increase the contrast ratio of liquid crystal displays.

These and other objects, features and advantages are provided, according to the present invention by a liquid crystal display comprising two parallel spaced substrates and a liquid crystal layer with negative dielectric anisotropy injected between two substrates wherein the ratio  $d/p$ , the cell gap  $d$  between two substrates to the pitch  $p$  of the liquid crystal layer, may be equal to or less than 0.3.

The liquid crystal layer is made of a chiral nematic liquid crystal or a nematic liquid crystal with 0.01-1.0 wt % of chiral dopant.

On two substrates, alignment layers are formed to align the liquid crystal molecules vertically to the substrates. The alignment layer may or may not be rubbed.

The refractive anisotropy  $\Delta n$  may be 0/065-0.123, the cell gap  $d$  between two substrates may be 3.0-6.0  $\mu\text{m}$  and the retardation value  $\Delta n \cdot d$  may be 0.25-0.4.

When the electric field is not applied, the liquid crystal molecules are arranged vertically to the substrates and, when the sufficient electric field is applied, the liquid crystal molecules are parallel to the substrates and twisted by 90° from one substrate to the other.

These and other objects, features and advantages are also provided, according to the present invention, by a liquid crystal display comprising a liquid crystal cell having a liquid crystal material with a negative dielectric anisotropy, and a combination of a-plate, c-plate or biaxial compensation films attached to the outer surface of the liquid-crystal cell.

The slow axis which is the direction having the largest refractive index of a-plate or biaxial compensation film may be parallel or perpendicular to the transmission axis of adjacent polarizer.

The difference between the summation of the retardation  $(n_{xa} - n_{za}) \cdot d_y$  of the a-plate compensation film, the retardation  $(n_{zc} - n_{zc}) \cdot d_c$  of the c-plate compensation film, the retardation  $(n_{xb} - n_{zb}) \cdot d_c$  of the biaxial compensation film and the retardation of the polarizers, and the retardation of the liquid crystal cell may be equal to or less than 15% of the retardation of the liquid crystal cell. The retardation  $(n_{xa} - n_{ya}) \cdot d_n$  of the a-plate compensation film or the retardation  $(n_{xb} - n_{yb}) \cdot d_b$  of the biaxial compensation film may be 0-100 nm. Here,  $n_x$ ,  $n_y$  and  $n_z$  are the refractive indices of the x, y and z axes respectively when z axis is the direction perpendicular to the surface of the liquid crystal cell, x axis is in the surface of the liquid crystal cell and having the largest refractive index of the a-plate or the biaxial compensation film and y axis is in the surface of the liquid crystal cell and

perpendicular to the x axis, and d is the thickness of the liquid crystal cell.

### BRIEF DESCRIPTION OF THE DRAWINGS

FIGS. 1A and 1B are schematic diagrams of the alignment of liquid crystal molecules of a VATN liquid crystal display respectively in black state and white state according to an embodiment of the present invention.

FIG. 2 is a sectional view of a VATN liquid crystal cell according to the present invention.

FIG. 3 is a graph showing transmittance T as a function of voltage V applied to the liquid crystal cell for various d/p in the Experiment 1.

FIGS. 4A, 4B and 4C show the viewing angle characteristics for various d/p in the Experiment 1.

FIG. 5 is a graph showing transmittance T as a function of voltage V applied to the liquid crystal cell for various d/p in the Experiment 2.

FIGS. 6A and 6B show the viewing angle characteristics for various d/p in the Experiment 2.

FIG. 7 is a graph showing transmittance T as a function of voltage V applied to the liquid crystal cell for various d/p in the Experiment 3.

FIGS. 8A, 8B and 8C show the viewing angle characteristics for various d/p in the Experiment 3.

FIG. 9 is a graph of the viewing angle in the 45° diagonal direction as a function of the retardation value.

FIG. 10 illustrates the relation between the cell gap and the response time.

FIGS. 11A–20 show the structures of the liquid crystal display according to the first to the sixteenth embodiments respectively.

FIG. 21 is a graph showing the contrast ratios in right, up, left and bottom 60° directions as a function of the retardation value  $(n_x - n_y) \cdot d$  for the LCD according to the tenth embodiment of the present invention shown in FIG. 14.

FIG. 22 is a graph showing the contrast ratios in right, up, left and bottom 60° directions as a function of the retardation value  $(n_{xb} - n_{yb}) \cdot d_b$  for the LCD according to the tenth embodiment of the present invention shown in FIG. 15.

FIG. 23 is a graph showing the contrast ratios in right, up, left and bottom 60° directions as a function of the retardation value  $(n_{xb} - n_{yb}) \cdot d_b$  for the LCD according to the thirteenth embodiment of the present invention shown in FIG. 17.

FIG. 24 shows the viewing angle characteristics of the VATN LCD according to the eleventh embodiment.

FIG. 25 shows the viewing angle characteristics of the VATN LCD according to the thirteenth embodiment.

FIG. 26 shows the 3-D luminance of the VATN LCD according to the eleventh embodiment.

FIG. 27 shows the 3-D luminance of the VATN LCD according to the thirteenth embodiment.

FIGS. 28A–28C show the 8 gray scale performance of the VATN LCD according to the thirteenth embodiment

FIGS. 29A–29D show the 8 gray scale performance of the 2-D VATN LCD having the structure of the thirteenth embodiment.

FIG. 30 shows the viewing angle characteristics of the 2-D VATN LCD having the structure of the tenth embodiment.

FIG. 31 shows the viewing angle characteristics of the VATN LCD having the structure of the eleventh embodiment.

### DETAILED DESCRIPTION OF THE PREFERRED EMBODIMENTS

The present invention will now be described more fully hereinafter with reference to the accompanying drawings, in which preferred embodiments of the present invention are shown. This invention may, however, be embodied in different forms and should not be construed as limited to the embodiments set forth herein. Rather, these embodiments are provided so that this disclosure will be thorough and complete, and will fully convey the scope of the invention to those skilled in the art. In the drawings, the thickness of layers and regions are exaggerated for clarity.

FIGS. 1A and 1B are schematic diagrams of the alignment of liquid crystal molecules of a VATN liquid crystal display respectively in black state and white state according to an embodiment of the present invention. FIG. 2 shows the structure of a VATN liquid crystal display according to an embodiment of the present invention.

As shown in FIGS. 1A and 1B, two transparent insulating substrates 1 and 2 are opposite and spaced apart from each other, and transparent electrodes 12 and 120 made of a transparent conductive material such as ITO (indium tin oxide). Alignment layers 14 and 140 are formed on the inner surfaces of the substrates 1 and 2. Between two substrates 1 and 2, a liquid crystal material layer 100 made of a chiral nematic liquid crystal having negative dielectric anisotropy or a nematic liquid crystal material doped with chiral dopant of 0.01–0.3 wt % is interposed. The ratio d/p, the cell gap d between the substrates 1 and 2 divided by the pitch p of the liquid crystal layer 100, is preferably equal to or less than 0.3, and the retardation value  $\Delta n \cdot d$  is preferably in the range of 0.25–0.4. On the outer surfaces of two substrates 1 and 2, a polarizer 13 and an analyzer 130, which polarize the rays incident on the liquid crystal material layer 100 and the rays out of the liquid crystal material layer 100 respectively, are attached. The polarizing direction of the polarizer 13 attached to the lower substrate 1 is perpendicular to that of the analyzer 130 attached to the upper substrate 2. Alignment layers 14 and 15 may be rubbed or not.

FIG. 1A shows the off state that the electric field is not applied, where the molecular axes of the liquid crystal molecules 3 in the liquid crystal layer 100 are aligned perpendicular to the surface of the substrates 1 and 2 by the aligning force of the alignment layers 14 and 15.

The polarized light by the polarizer 13 passes through the liquid crystal layer 100 without changing; its polarization. Then, the light is blocked by the analyzer 130 to make a black state.

FIG. 1B shows the on state that the sufficient electric field is applied to the liquid crystal layer by the electrodes 4 and 5, where the liquid crystal molecules 3 in the liquid crystal layer 100 are twisted spirally by 90° from the lower substrate 1 to the upper substrate 2 and the director of the liquid crystal layer varies continuously. Near the inner surfaces of two substrates 1 and 2, the aligning force of the alignment layers 14 and 15 is larger than the force due to the applied electric field, and thus the liquid crystal molecules stay vertically aligned.

The polarized light by the polarizer 13 passes through the liquid crystal layer 100, and its polarization is rotated by 90° according to the variation of the director of the liquid crystal layer. Accordingly the light passes through the analyzer 130 to make a white state.

Next, the experiments according to the present invention will be described.

FIG. 2 is a sectional view of a VATN liquid crystal cell according to the present invention.

As shown in FIG. 2, a liquid crystal layer **100** is interposed between two parallel substrates **1** and **2** spaced apart from each other. Spacers **200** are mixed with the liquid crystal layer **100** to sustain the gap between the substrates **1** and **2**. On the inner surfaces of the substrates **1** and **2** near the edge of the substrates **1** and **2**, a sealant **300** is formed to prevent the liquid crystal material from flowing out of the cell.

#### Experiment 1

In this experiment, JALS204, JALS572 (Japan Synthetic Rubber Co.) or SE-1211 (Nissan Chemical Co.) which are used for homeotropic alignment layers were used as an alignment layer. Plastic spacers having 4.5  $\mu\text{m}$  diameter were included in the sealant **300**, and the diameter of spacers spread on the substrate **1** or **2** to maintain the cell gap was 4.5  $\mu\text{m}$ . Liquid crystal material, which is filled in the gap between the substrates, was a twisted nematic liquid crystal material with negative dielectric anisotropy and doped with a dopant MLC 6247 (Merck Co.). The refractive anisotropy  $\Delta n$  of the liquid crystal was 0.085, the dielectric anisotropy  $\Delta\epsilon$  was 4.5, the elastic constant  $K_{11}$ , was 15.4 pN,  $K_{22}$  was 5.8 pN and  $K_{33}$  was 17.4 pN, and the viscosity was 30  $\text{mm}^2/\text{s}$ . The cell gap  $d$  varies from 3  $\mu\text{m}$  to 6  $\mu\text{m}$ , and the pitch  $p$  is adjusted by varying the amount of the added dopant.

FIG. 3 is a graph showing transmittance  $T$  as a function of voltage  $V$  applied to the liquid crystal cell for various  $d/p$ , and FIGS. 4A, 4B and 4C show the viewing angle characteristics for various  $d/p$  in the Experiment 1.

As shown in FIG. 3, the transmittance  $T$  increases as  $d/p$  decreases. When  $d/p$  is 0.5, the transmittance is less than 10%. However, if  $d/p$  is 0.1 or 0.3, the transmittance has relatively high value more than 18%. The voltage difference between the electrodes is in the range of 0–10 V.

As a result, the transmittance  $T$  increases as  $d/p$  decreases, and the transmittance is high when the  $d/p$  is less than 0.3.

When  $d/p$  is 0.5, the viewing angles in up, down, left and right directions are about  $40^\circ$  and those in diagonal directions are less than  $90^\circ$  partly as shown in FIG. 4C. However, as shown in FIGS. 4A and 4B, when  $d/p$  is 0.1 or 0.3, the viewing angles in up, down, left and right directions are larger than  $40^\circ$  and those in diagonal directions are more than  $90^\circ$ .

#### Experiment 2

In this experiment, the structure of liquid crystal cell was the same as in the first experiment except the alignment layers. In Experiment 2, an alignment layer **14** was rubbed in the direction of  $45^\circ$  polar angle. As a result of the rubbing, the liquid crystal molecules were tilted by about  $1^\circ$  with respect to the perpendicular direction to the substrate.

FIG. 5 is a graph showing transmittance  $T$  as a function of voltage  $V$  applied to the liquid crystal cell for various  $d/p$ , and FIGS. 6A and 6B show the viewing angle characteristics for various  $d/p$  in the Experiment 2.

As shown in FIG. 5, when  $d/p$  is 0.5, the transmittance is less than 10% for the sufficient applied voltage. However, when  $d/p$  is 0.1, the transmittance increases to more than 10% as the voltage increases, and when  $d/p$  is 0.3, the transmittance is over 20%. The voltage difference between the electrodes is in the range of 0–5 V.

FIGS. 6A and 6B show the viewing angle characteristics. When  $d/p$  is 0.5, as shown in FIG. 6B, the viewing angles in up and down directions are more than  $90^\circ$  but those in left and right directions are less than  $90^\circ$ . However, as shown in FIG. 6A, in the case that  $d/p$  is 0.3, all the viewing angles in up, down, left and right directions are over  $90^\circ$ .

#### Experiment 3

In this experiment, the structure of the liquid crystal cell was the same as in the first experiment except the alignment layers. In Experiment 3, two alignment layers **14** and **15** were rubbed in the direction of  $0^\circ$  polar angle and  $90^\circ$  polar angle respectively, therefore the rubbing directions of two alignment layers **14** and **15** are perpendicular to each other.

FIG. 7 is a graph showing transmittance  $T$  as a function of voltage  $V$  applied to the liquid crystal cell for various  $d/p$ , and FIGS. 8A, 8B and 8C show the viewing angle characteristics for various  $d/p$  in the Experiment 3.

As shown in FIGS. 7 and 8A–8C, the transmittance  $T$  decreases as  $d/p$  increases, and thus the contrast ratio decreases and the viewing angle characteristics become worse.

As shown in FIG. 7, when  $d/p$  is 0.5, the transmittance is less than 10% for the sufficient applied voltage. However, when  $d/p$  is 0.3, the transmittance increases to more than 25% as the voltage increases, and when  $d/p$  is 0.1, the transmittance is over 35%. The voltage difference between the electrodes is in the range of 0.5 V.

As shown in FIGS. 8A and 8C, when  $d/p$  is 0.1 or 0.5, the viewing angle in up, down, left and right directions are larger than  $90^\circ$ . However, as shown in FIG. 8B, when  $d/p$  is 0.3, the viewing angles in up, down, left and right directions are about  $90^\circ$ .

#### Experiment 4

In this experiment, the dependency of the viewing angle characteristics in diagonal directions on the retardation value  $\Delta nd$  was tested. As in Experiment 3, all the alignment layers **14** and **15** were rubbed. An varies in the range of 0.065–0.123 and the cell gap  $d$  varies in the range of 3.0–6.0  $\mu\text{m}$  to vary the retardation value  $\Delta nd$  in the range of 0.3–0.6.

FIG. 9 is a graph of the viewing angle in the  $45^\circ$  diagonal direction as a function of the retardation value.

As shown in FIG. 9, the retardation value  $\Delta nd$  is preferably equal to or less than 0.4 to get a wide viewing angle over  $140^\circ$ .

#### Experiment 5

In this experiment, the dependency of the response time on the cell gap and  $d/p$  was measured. Two test cells were used having the cell gap of 4.0  $\mu\text{m}$  and 4.5  $\mu\text{m}$  respectively, and  $d/p$  varied in the range of 0.1–0.5 by adjusting the amount of the added dopant. Other conditions were the same as in Experiment 4.

FIG. 10 is a graph of the response time as a function of the cell gap and  $d/p$ .

As shown in FIG. 10, the response time is shorter as the cell gap and  $d/p$  is smaller. If the cell gap is narrow, the electric field is stronger than when the cell gap is small, and, therefore, the liquid crystal molecules respond faster. The response time increases as  $d/p$  increases because the viscosity of the liquid crystal material increases as the density of dopant increases.

Now, film-compensated VATN liquid crystal displays according to the embodiments of the present invention will be described in detail. FIGS. 11A–20 show the structures of VATN liquid crystal displays according to the embodiments.

A VATN liquid crystal display according to the first embodiment of the present invention is shown in FIG. 11A.

A liquid crystal cell **50** having a liquid crystal material with negative dielectric anisotropy such as that as shown in FIG. 1A is prepared. A polarizer **10** is attached on the outer surface of rear side of the liquid crystal cell **50**. On the outer surface of the front side of the liquid crystal cell **50** an a-plate compensation film **20**, a c-plate compensation film **30** and another polarizer **11** are attached in sequence. The

buffing direction of an alignment layer (such as **14** in FIG. **1A**) on the inner surface of the front side of the liquid crystal cell **50** up-right. The solid arrow indicates the buffing direction of the alignment layer the front side of the liquid crystal cell. On the contrary, the buffing direction of an alignment layer (such as **15** in FIG. **1A**) on the inner surface of the rear side of the liquid crystal cell **50** is down-right. The dotted arrow indicates the buffing direction of the alignment layer on the rear side of the liquid crystal cell. In the first embodiment of the present invention, the liquid crystal cell operates in "e" mode that the polarizing directions of the polarizers **10** and **11** represented by bidirectional arrows are parallel to the buffing directions of the neighboring alignment layers.

An a-plate compensation film has the refractive indices  $n_x$ ,  $n_y$ , and  $n_z$  satisfying the relation  $n_x > n_y = n_z$ , and a c-plate compensation has the refractive indices satisfying the relation  $n_x = n_y > n_z$ , where  $n_x$ ,  $n_y$ , and  $n_z$  are respectively the refractive indices in the x-direction, y-direction and z-direction when the z-direction is perpendicular to the surface of the liquid crystal cell **50**, and the x-axis and y-axis spans a plane parallel to the surface of the liquid crystal cell **50**.

The x-axis of the a-plate compensation film, which has a largest refractive index (slow axis), may match with or be perpendicular to the polarizing direction of its neighboring polarizer. If not, the light leakage may be generated to reduce the contrast ratio. In the case that the liquid crystal display shown in FIG. **11A**, the x-axis of the a-plate compensation film **20** is in the up-right direction and parallel to the polarizing direction of the polarizer **11**. The solid bidirectional arrow drawn on the a-plate compensation film **20** indicates the direction of the x-axis of the a-plate compensation film **20**.

According to the second embodiment, as shown in FIG. **11B**, the positions of a-plate and c-plate compensation films are exchanged. On the rear side of the liquid crystal cell **50**, a polarizer **10** is attached. An a-plate compensation film **20**, a c-plate compensation film **30** and a polarizer **11** is attached on the front side of the liquid crystal cell **50** in sequence. The buffing directions of the alignment layer, the polarizing directions of the polarizer **10** and **11** and the x-axis of the a-plate compensation film **20** are similar to those of the first embodiment.

Liquid crystal displays according to the third and the fourth embodiments are shown in FIGS. **11C** and **11D** respectively, where the compensation films **20** and **30** are inserted between the rear polarizer **10** and the liquid crystal cell **50**. According to the third embodiment, a c-plate compensation film **30**, an a-plate compensation film **20** and a polarizer **10** are attached in sequence on the rear side of the liquid crystal cell **50** (FIG. **11C**). In the fourth embodiment, the positions of the c-plate compensation film **30** and the a-plate compensation film **20** are opposite to those in the third embodiment (FIG. **11D**). The buffing directions of the alignment layers and the polarizing directions of the polarizers **10** and **11** are similar to those of the first embodiment. The x-axis of the a-plate compensation film **20** is matched with the polarizing direction of the rear polarizer **10** neighboring to the a-plate compensation film **20**.

FIGS. **12A**–**12D** illustrate liquid crystal displays according to the fifth to the eighth embodiment, and the liquid crystal displays operate in "o" mode. Arrangements of a liquid crystal cell **50**, polarizers **10** and **11**, an a-plate compensation film **20** and a c-plate compensation film **30** are substantially the same as those of the liquid crystal displays shown in FIGS. **11A**–**11D**. The difference is that the liquid crystal displays operate in "o" mode, that is, the buffing

directions of alignment layers are perpendicular to the polarizing directions of the neighboring polarizers, and that the buffing directions of the alignment layers are perpendicular to x-axis of the a-plate compensation films.

FIG. **13** illustrates a liquid crystal display according to the ninth embodiment. The liquid crystal display has another c-plate compensation film **31** inserted between the liquid crystal cell **50** and the rear polarizer **10** in the first embodiment. The liquid crystal display according to the tenth embodiment, as shown in FIG. **14**, has another a-plate compensation film **21** inserted between the c-plate compensation film **31** and the rear polarizer **10** in the ninth embodiment, and the x-axis of the a-plate film **21** is parallel to the polarizing direction of the rear polarizer **10**.

A liquid crystal display according to the eleventh embodiment is shown in FIG. **15**. A rear polarizer **10** is attached to the rear side of a liquid crystal cell **50** having a liquid crystal material with negative dielectric anisotropy. On the opposite side of the liquid crystal cell, a biaxial compensation film **40** is interposed between the liquid crystal cell **50** and a front polarizer **11**. The biaxial compensation film has the refractive indices satisfying the relation that  $n_x > n_y > n_z$ . As in the embodiments described above, the x-axis of the biaxial compensation film may be parallel or perpendicular to the polarizing direction of its neighboring polarizer. It may operate in "e" mode or "o" mode.

According to the twelfth embodiment; a biaxial compensation film **40** is interposed between a rear polarizer **10** and the rear side of a liquid crystal cell **50** and a front polarizer **11** is attached directly on the front side of the liquid crystal cell **50**, as shown in FIG. **16**. As in the embodiments described above, the x-axis of the biaxial compensation film may be parallel or perpendicular to the polarizing direction of its neighboring polarizer. It may operate in "e" mode or "o" mode.

As shown in FIG. **17**, according to the thirteenth embodiment, two biaxial compensation films **40** and **41** are inserted between respective polarizers **10** and **11** and the front and rear side of a liquid crystal cell **50**, respectively. As in the embodiments described above, the x-axis of the biaxial compensation film may be parallel or perpendicular to the polarizing direction of its neighboring polarizer. It may operate in "e" mode or "o" mode.

A liquid crystal display according to the fourteenth embodiment is shown in FIG. **18**. A rear polarizer **10** is attached to the rear side of a liquid crystal cell **50** having a liquid crystal material with negative dielectric anisotropy. On the opposite side of the liquid crystal cell a biaxial compensation film **40** and a c-plate compensation film **30** are inserted between the liquid crystal cell **50** and a front polarizer **11**. The x-axis of the biaxial compensation film **40** is parallel to the polarizing direction of its neighboring polarizer **11**. The liquid crystal cell operates in "e" mode that the polarizing directions are parallel to the buffing directions of the neighboring alignment layers in this embodiment. The position of the biaxial compensation film **40** and the c-plate compensation film **30** may be exchanged, and they may be inserted between a rear polarizer **10** and the liquid crystal cell **50**.

Another c-plate compensation film **31** may be added between the rear polarizer **10** and the liquid crystal cell of the fourteenth embodiment, according to the fifteenth embodiment as shown in FIG. **19**. A c-plate compensation film and a biaxial compensation film may be added to the LCD of fourteenth embodiment as in the sixteenth embodiment (FIG. **20**). The x-axis of the biaxial compensation film may be perpendicular to the polarizing direction of the neighboring polarizer, and the liquid crystal display may operate in "o" mode.

In the meantime, the contrast ratio CR for the VATN LCD is defined as follows:

$$CR = (\text{luminance})_{ON} / (\text{luminance})_{OFF}$$

That is, the contrast ratio in normally black mode is the value that  $(\text{luminance})_{ON}$ , which is the luminance at the state that the voltage is applied (on state), divided by  $(\text{luminance})_{OFF}$ , which is the luminance at the state that the voltage is not applied (off state). The contrast ratio may be drastically improved if somehow the luminance in off state is further reduced.

The viewing angle characteristics and gray scale performance of the film compensated VATN LCD, according to the present invention were calculated by optical simulation program. The geometrical structure and relevant parameters used in the simulation are summarized in Table. 1. It was assumed that the polarizer itself gives retardation of  $-60$  nm.

TABLE 1

The parameters of VATN cells for optical simulations		
Elastic constant (pN)	$K_1$	16.6
	$K_2$	6.5
	$K_3$	18.5
Relative dielectric constant	$\epsilon_a$	3.5
	$\epsilon_{\perp}$	7.7
Refractive index	$n_a$	1.5584
	$n_o$	1.4757
Pretilt angle	$\theta_D$	$89^\circ$
Twist angle	$\Phi_{TN}$	$90^\circ$
Cell gap ( $\mu\text{m}$ )	$d$	4.0
Cell gap divided by Pitch	$d/p$	0.1
Off state voltage (V)	$V_{off}$	0
On state voltage (V)	$V_{on}$	5
Buffing direction	front	$45^\circ$ or $225^\circ$
	back	$315^\circ$ or $135^\circ$

The net retardation value due to all retardation films (including the polarizers),  $(n_x - n_z) * d$ , is preferably equal to that of the liquid crystal cell birefringence. In our case, the liquid crystal cell birefringence was around 320 nm. However, the biaxiality of the compensation films may be optimized in the individual case.

FIG. 21 is a graph showing the contrast ratios in right, up, left and bottom  $60^\circ$  directions as a function of the retardation value  $(n_x - n_y) * d$  for the LCD according to the tenth embodiment of the present invention shown in FIG. 14.

Referring to FIG. 14, the structure of the VATN LCD according to the tenth embodiment of the present invention is more fully described. A liquid crystal cell 50 has a liquid crystal material with negative dielectric anisotropy. On the front side of the liquid crystal cell 50, a c-plate compensation film 30 and an a-plate compensation film 20 is attached in sequence, and a polarizer 11 is attached thereto. On the rear side of the liquid crystal cell 50, a c-plate compensation film 31 and an a-plate compensation film 11 is attached in sequence, and a polarizer 11 is also attached thereto. The polarizing directions of the polarizers 10 and 11 are parallel to the buffing direction of their neighboring alignment layers of the liquid crystal cell 50. That is, the liquid crystal cell operates in "e" mode. The orientation of x-axis (slow axis) of a-plate compensation film 20 and 21 matches with the polarizing direction of its neighboring polarizer.

The optimum retardation value  $(n_{xa} - n_{ya}) * d_a$  of the a-plate compensation film is around 20 nm as shown in graph of FIG. 21 where  $n_{xa}$  and  $n_{ya}$  are respectively the refractive indices along the x-axis and the y-axis of the a-plate compensation films, and  $d_a$  is the thickness of the a-plate compensation film. The maximum contrast ratio is 140:1 in up  $60^\circ$  direction.

FIG. 22 is a graph showing the contrast ratios in night up, left and bottom  $60^\circ$  directions as a function of the retardation value  $(n_{xb} - n_{yb}) * d_b$  for the LCD according to the tenth embodiment of the present invention shown in FIG. 15 where  $n_{xb}$  and  $n_{yb}$  are respectively the refractive indices along the x-axis and the y-axis of the biaxial compensation films, and  $d_b$  is the thickness of the biaxial compensation film. The optimum retardation value  $(n_{xb} - n_{yb}) * d_b$  of the biaxial compensation film is around 50 nm as shown in FIG. 22.

If a biaxial compensation film is used as in the eleventh embodiment of the present invention, the contrast ratio may be more improved. As shown in FIG. 22, the contrast ratio is over 175:1 in up  $60^\circ$  direction. The contrast ratio in left and right  $60^\circ$  directions are about 250:1 and 175:1, respectively.

FIG. 23 is a graph showing the contrast ratios in right, up, left and bottom  $60^\circ$  directions as a function of the retardation value  $(n_{xb} - n_{yb}) * d_b$  for the LCD according to the thirteenth embodiment of the present invention shown in FIG. 17.

Referring to FIG. 17 the structure of the VATN LCD according to the thirteenth embodiment of the present invention is described in detail. A liquid crystal cell 50 has a liquid crystal material with negative dielectric anisotropy. Both on the front and rear side of the liquid crystal cell 50, two biaxial compensation films 40 and 41 and two polarizers 11 and 10 are attached respectively. The liquid crystal cell operates in "e" mode that the polarizing directions of the polarizers 10 and 11 are parallel to the buffing directions of their neighboring alignment layers of the liquid crystal cell 50. The orientation of x-axis (slow axis) of biaxial compensation film 40 and 41 matches with the polarizing direction of its neighboring polarizer.

The optimum retardation value  $(n_{xb} - n_{yb}) * d_b$  of the biaxial compensation film is around 40 nm as shown in FIG. 23. The contrast ratio is as good as in the eleventh embodiment of the present invention.

The contrast ratio in up  $60^\circ$  direction is about 200:1, and the contrast ratios in left and right  $60^\circ$  directions are over 250:1.

In the tenth embodiment of the present invention, if the retardation value  $(n_{xc} - n_{zc}) * d_c$  of the c-plate compensation films 30 and 31 is 100 nm, the net retardation value of all retardation films (including the polarizers),  $(n_x - n_z) * d$ , is 360 nm because the retardation value of the a-plate compensation film is 20 nm and the retardation value of the polarizer is 60 nm. This value is nearly equal to the liquid crystal cell birefringence.

In the eleventh embodiment of the present invention, if the retardation value  $(n_{xb} - n_{zb}) * d_b$  of the biaxial compensation films 40 is 200 nm, the total retardation value of all retardation films,  $(n_x - n_z) * d$ , is 320 nm. This value is equal to the liquid crystal cell birefringence.

In the thirteenth embodiment of the present invention, if the retardation value  $(n_{xb} - n_{zb}) * d_b$  of the biaxial compensation films 40 and 41 is 100 nm, the net retardation value of all retardation  $(n_x - n_z) * d$ , is 320 nm as in the eleventh embodiment of the present invention.

As shown in the above, if the difference between the net retardation value of all retardation,  $(n_x - n_z) * d$ , and the liquid crystal cell birefringence is relatively small, the viewing characteristics are much improved. The difference is preferably equal to or less than 15% of the liquid crystal cell birefringence.

FIGS. 24 and 25 show the viewing angle characteristics of the film compensated VATN LCDs according to the eleventh and thirteenth embodiments of the present

invention, respectively. The viewing angle characteristics are dramatically improved compared with the cases that the compensation film is not used and that c-plate compensation films are used.

FIGS. 26 and 27 show the 3 dimensional luminance distributions of the film compensated VATN LCDs according to the eleventh and thirteenth embodiments of the present invention, respectively. A VATN LCD in off state has the intrinsic light leakage in 45° direction relative to the polarizing direction. The c-plate compensation film with optimum value may reduce the light leakage by 10 times. The optimum black states of the VATN LCDs may be achieved by using the biaxial compensation films according to embodiments of the present invention. It results in the extremely high contrast ratio.

The eight gray scale performance of the VATN LCD according to the thirteenth embodiment using the optimum biaxial compensation film is calculated, and the calculated result is shown in FIGS. 28A–28C. FIG. 28A is the graph of the luminance as a function of the azimuthal angle in the plane making 45° relative to the polarizing directions. FIG. 28B is the graph of the luminance as a function of the azimuthal angle in the vertical plane to the polarizing direction, and FIG. 23C is the graph of the luminance as a function of the azimuthal angle in the horizontal plane to the polarizing direction. Although the contrast of the display gets improved a lot in these compensation modes, the gray scale performances are not so good enough.

If the compensation configurations according to the embodiments of the present invention are adapted to 2-domain VATN LCD, the gray scale performance gets greatly improved. FIGS. 29A–29D show the gray scale performance of 2-D VATN LCD having the compensation configuration according to the thirteenth embodiment of the present invention. FIG. 29A is the graph of the luminance as a function of the azimuthal angle in the horizontal plane to the polarizing direction. FIG. 29B is the graph of the luminance as a function of the azimuthal angle in the vertical plane to the polarizing direction, and FIGS. 29C and 29D are respectively the graph of the luminance as a function of the azimuthal angle in the planes making 45° and 135° relative to the polarizing direction.

FIGS. 30 and 31 show the gray scale performances of 2-D VATN LCDs having the compensation configurations according to the tenth and the eleventh embodiments of the present invention, respectively.

All compensation configurations shown in FIGS. 11A–20 can be used for 2-D or multi-domain VATN LCDs as long as the buffing directions match with the x-axis (slow axis) of the biaxial or the a-plate compensation film.

Moreover, the film compensated VATN LCDs according to the present invention may be adapted to ECB (electrically controlled birefringence) VATN LCDs, fringe controlled multi-domain VATN LCDs. IPS (in-plane switching) mode VATN LCDs, etc.

In the drawings and specification, there have been disclosed typical preferred embodiments of the invention and, although specific terms are employed, they are used in a generic and descriptive sense only and not for purposes of limitation, the scope of the invention being set forth in the following claims.

What is claimed is:

1. A liquid crystal display comprising:

a vertically aligned liquid crystal cell having a first surface and a second surface opposite each other and having a liquid crystal material with negative dielectric anisotropy;

a first and a second polarizers attached to the first and the second surfaces of the liquid crystal cell respectively; and

a first biaxial compensation film and a first c-plate compensation film disposed between the first surface of the liquid crystal cell and the first polarizer,

wherein a direction having a largest refractive index in the first biaxial compensation film is parallel or perpendicular to the polarizing direction of the first polarizer, wherein the difference between the summation of the retardation  $(n_{xb1}-n_{zb1}) * d_{b1}$  of the first biaxial compensation film, the retardation  $(n_{xc1}-n_{zc1}) * d_{c1}$  of the first c-plate compensation film and the retardation of the first and the second polarizers, and the retardation due to birefringence of the liquid crystal cell is equal to or less than 15% of the retardation value due to birefringence of the liquid crystal cell,

where a z-axis is perpendicular to the first plane of the liquid crystal cell, a x-axis is the same direction as the direction having a largest refractive index in the first biaxial compensation film,  $n_{xb1}$ ,  $n_{zb1}$ ,  $n_{xc1}$  and  $n_{zc1}$  are the refractive indices along the x-axis and the z-axis of the first biaxial and the first c-plate compensation film, respectively, and  $d_{b1}$  and  $d_{c1}$  are the thickness of the first biaxial and the first c-plate compensation films, respectively.

2. The liquid crystal display of claim 1, wherein the retardation value  $(n_{xb1}-n_{yb1}) * d_{b1}$  of the first biaxial compensation film is in the range of 0–100 nm,

where a y-axis is in the first plane and the perpendicular to the x-axis,  $n_{yb1}$  is the refractive index of the first biaxial compensation film along the y-axis.

3. The liquid crystal display of claim 2, wherein the liquid crystal cell comprises:

a pair of transparent substrates;

homeotropic alignment layers which are formed on the substrates and divided into two regions whose buffing directions are different; and

a liquid crystal material with negative dielectric anisotropy interposed between the alignment layers.

4. The liquid crystal display of claim 3, wherein the buffing direction of the alignment layer adjacent to the first biaxial compensation film matches with the direction having the largest refractive index of the first biaxial compensation film.

5. The liquid crystal display of claim 1, further comprising a second c-plate compensation film attached to the second surface of the liquid crystal cell.

6. The liquid crystal display of claim 5, wherein the difference between the summation of the retardation  $(n_{xb1}-n_{zb1}) * d_{b1}$  of the first biaxial compensation film, the retardation  $(n_{xc1}-n_{zc1}) * d_{c1}$  of the first c-plate compensation film, the retardation  $(n_{xc2}-n_{zc2}) * d_{c2}$  of the second c-plate compensation film and the retardation of the first and the second polarizers, and the retardation due to birefringence of the liquid crystal cell is equal to or less than 15% of the retardation value due to birefringence of the liquid crystal cell,

where a z-axis is perpendicular to the first plane of the liquid crystal cell, a x-axis is the direction having a largest refractive index in the first biaxial compensation film,  $n_{xb1}$ ,  $n_{zb1}$ ,  $n_{xc1}$ ,  $n_{zc1}$ ,  $n_{xc2}$  and  $n_{zc2}$  are respectively the refractive indices along the x-axis and the z-axis of the first biaxial, the first c-plate and the second c-plate compensation film, and  $d_{b1}$ ,  $d_{c1}$ , and  $d_{c2}$  are the thickness of the first biaxial, the first c-plate and the second c-plate compensation films respectively.

13

7. The liquid crystal display of claim 6, wherein the retardation value  $(n_{xb1}-n_{yb1}) \cdot d_{b1}$  of the first biaxial compensation film is in the range of 0–100 nm,

where a y-axis is in the first plane and perpendicular to the x-axis,  $n_{yb1}$  is the refractive index of the first biaxial compensation film along the y-axis.

8. The liquid crystal display of claim 7, wherein the liquid crystal cell comprises:

a pair of transparent substrates;

homeotropic alignment layers formed on the substrates and divided into two regions whose buffing directions are different; and

a liquid crystal material with negative dielectric anisotropy interposed between the alignment layers.

9. The liquid crystal display of claim 8, wherein the buffing direction of the alignment layer adjacent to the first biaxial compensation film matches with the direction having the largest refractive index of the first biaxial compensation film.

10. The liquid crystal display of claim 1, further comprising a second biaxial compensation film attached to the second c-plate compensation film.

11. The liquid crystal display of claim 10, wherein the direction having a largest refractive index in the second biaxial compensation film is parallel or perpendicular to the polarizing direction of the second polarizer.

12. The liquid crystal display of claim 11, wherein the difference between the summation of the retardation,  $(n_{xb1}-n_{zb1}) \cdot d_{b1}$  of the first biaxial compensation film, the retardation  $(n_{xb2}-n_{zb2}) \cdot d_{b2}$  of the second biaxial compensation film, the retardation  $(n_{xc1}-n_{zc1}) \cdot d_{c1}$  of the first c-plate compensation film, the retardation  $(n_{xc2}-n_{zc2}) \cdot d_{c2}$  of the second c-plate compensation film and the retardation of the first and the second polarizers, and the retardation due to birefringence of the liquid crystal cell is equal to or less than 15% of the retardation value due to birefringence of the liquid crystal cell,

14

where a z-axis is perpendicular to the first plane of the liquid crystal cell, a x-axis is the direction having a largest refractive index in the first or the second biaxial compensation film,  $n_{xb1}, n_{zb1}, n_{xb2}, n_{zb2}, n_{xc1}, n_{zc1}, n_{xc2}$  and  $n_{zc2}$  are respectively the refractive indices along the x-axis and the z-axis of the first biaxial, the second biaxial, the first c-plate and the second c-plate compensation film, and  $d_{b1}, d_{b2}, d_{c1}$  and  $d_{c2}$  are the thickness of the first biaxial, the second biaxial, the first c-plate and the second c-plate compensation films respectively.

13. The liquid crystal display of claim 12, wherein the summation of the retardation value  $(n_{xb1}-n_{yb1}) \cdot d_{b1}$  of the first biaxial compensation film and the retardation value  $(n_{xb2}-n_{yb2}) \cdot d_{b2}$  of the second biaxial compensation film is in the range of 0–100 nm,

where a y-axis is in the first plane and perpendicular to the x-axis,  $n_{yb1}, n_{yb2}$  are the refractive indices of the first biaxial and the second biaxial compensation films along the y-axis.

14. The liquid crystal display of claim 13, wherein the liquid crystal cell comprises:

a pair of transparent substrates;

homeotropic alignment layers formed on the substrates and divided into two regions whose buffing directions are different; and

a liquid crystal material with negative dielectric anisotropy interposed between the alignment layers.

15. The liquid crystal display of claim 14, wherein the buffing directions of the alignment layers adjacent to the first and the second biaxial compensation films match with the directions having the largest refractive index of the first and the second biaxial compensation films.

\* \* \* \* \*

专利名称(译)	液晶显示装置具有宽视角和改善的对比度		
公开(公告)号	<a href="#">US6943858</a>	公开(公告)日	2005-09-13
申请号	US10/655516	申请日	2003-09-04
[标]申请(专利权)人(译)	LYU JAE 金 LEE HEA RI KIM KYEONG 铉 陈健MIN		
申请(专利权)人(译)	LYU JAE-JIN 李HEA-RI KIM KYEONG 铉 陈建民		
当前申请(专利权)人(译)	三星DISPLAY CO. , LTD.		
[标]发明人	LYU JAE JIN LEE HEA RI KIM KYEONG HYEON CHEN JIAN MIN		
发明人	LYU, JAE-JIN LEE, HEA-RI KIM, KYEONG-HYEON CHEN, JIAN-MIN		
IPC分类号	G02F1/13 G02F1/139 G02F1/1335 G02F1/13363 G02F1/1337 C09K19/02		
CPC分类号	G02F1/133634 G02F1/1393 G02F1/1337 G02F1/13363 G02F1/1396 G02F2001/13712 G02F2001/133742		
审查员(译)	NGUYEN , 龚便T.		
优先权	1019970021709 1997-05-29 KR 1019970028480 1997-06-27 KR		
其他公开文献	US20040046916A1		
外部链接	<a href="#">Espacenet</a> <a href="#">USPTO</a>		

摘要(译)

液晶显示装置包括垂直排列的液晶盒，该液晶盒具有彼此相对延伸的第一和第二表面，并且其中含有具有负介电各向异性的液晶材料。第一和第二偏振器分别连接到液晶单元的第一和第二表面。提供第一-a-板补偿膜和第一-c-板补偿膜。这些膜设置在液晶盒的第一表面和第一偏振器之间。第一-a-板补偿膜中具有最大折射率的方向平行于或垂直于第一偏振器的偏振方向。此外，第一-a-板补偿膜的延迟  $(n_{x21}-n_{za1}) \times da1$  的总和，第一-c-板补偿膜的延迟  $(n_{xc1}-n_{zc1}) \times dc1$  与第一和第一-a板的延迟之间的差值。由于液晶单元的双折射，第二偏振器和由于液晶单元的双折射引起的延迟等于或小于延迟值的15%。

