



(19) **United States**

(12) **Patent Application Publication**  
**Zhu et al.**

(10) **Pub. No.: US 2008/0043188 A1**

(43) **Pub. Date: Feb. 21, 2008**

(54) **TRANSFLECTIVE LIQUID CRYSTAL DISPLAY WITH VERTICAL ALIGNMENT**

(52) **U.S. Cl. .... 349/114; 445/24**

(75) **Inventors: Xinyu Zhu, Orlando, FL (US); Zhibing Ge, Orlando, FL (US); Shin-Tson Wu, Oviedo, FL (US)**

(57) **ABSTRACT**

Correspondence Address:  
**LAW OFFICES OF BRIAN S STEINBERGER**  
**101 BREVARD AVENUE**  
**COCOA, FL 32922 (US)**

A transflective liquid crystal display with uniform cell gap configuration throughout the transmissive and the reflective display region is invented. Mutually complementary common electrode pattern and reflector pattern or mutually complementary ITO pixel electrode pattern and reflector pattern produce an electric field in the transmissive display region that has a uniform longitudinal field and an electric field in the reflective display region that is a fringing field. An initially vertically aligned negative dielectric anisotropic nematic liquid crystal material between the electrodes forms a smaller tilt angle with respect to the substrate normal in the reflective display region while a larger tilt angle with respect to the substrate normal in the transmissive display region. Consequently, the ambient incident light experiences smaller phase retardation in the reflective display region while the light from the backlight source experiences larger phase retardation. Since the ambient light passes through the reflective display region twice while the light from the backlight source passes through the transmissive display region only once, by properly designing the electrodes and the reflector width, the light from both ambient light source and backlight source will experience almost the same phase retardation in both reflective and transmissive display regions. As a result, the electro-optical performance curves of both-transmissive display mode and reflective display mode overlap.

(73) **Assignees: RESEARCH FOUNDATION OF THE UNIVERSITY OF CENTRAL FLORIDA, INCORPORATED; TOP-POLY OPTOELECTRONICS CORP.,**

(21) **Appl. No.: 11/975,230**

(22) **Filed: Oct. 18, 2007**

**Related U.S. Application Data**

(62) **Division of application No. 11/110,229, filed on Apr. 20, 2005.**

**Publication Classification**

(51) **Int. Cl.**  
**G02F 1/1335 (2006.01)**  
**H01J 9/20 (2006.01)**

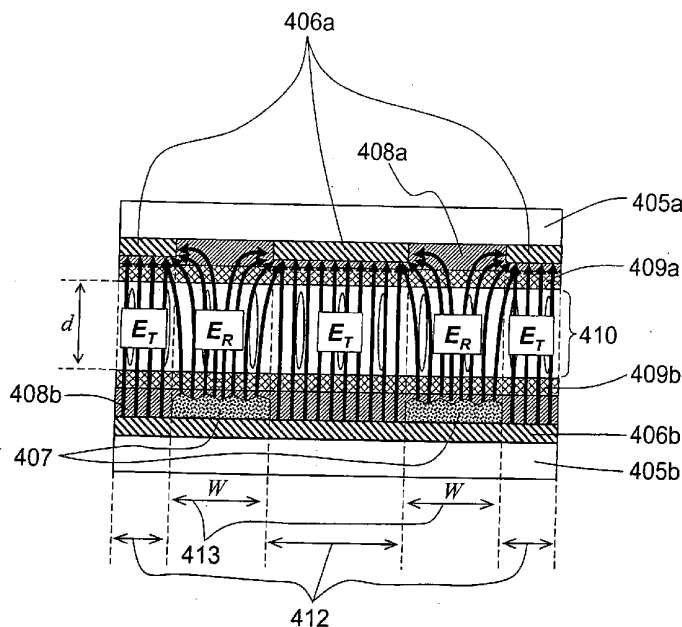

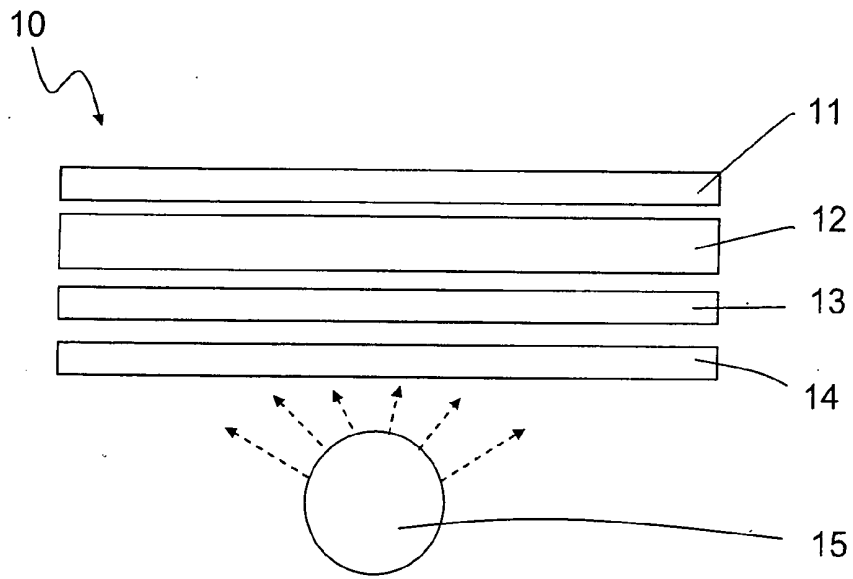

FIG. 1  
PRIOR ART

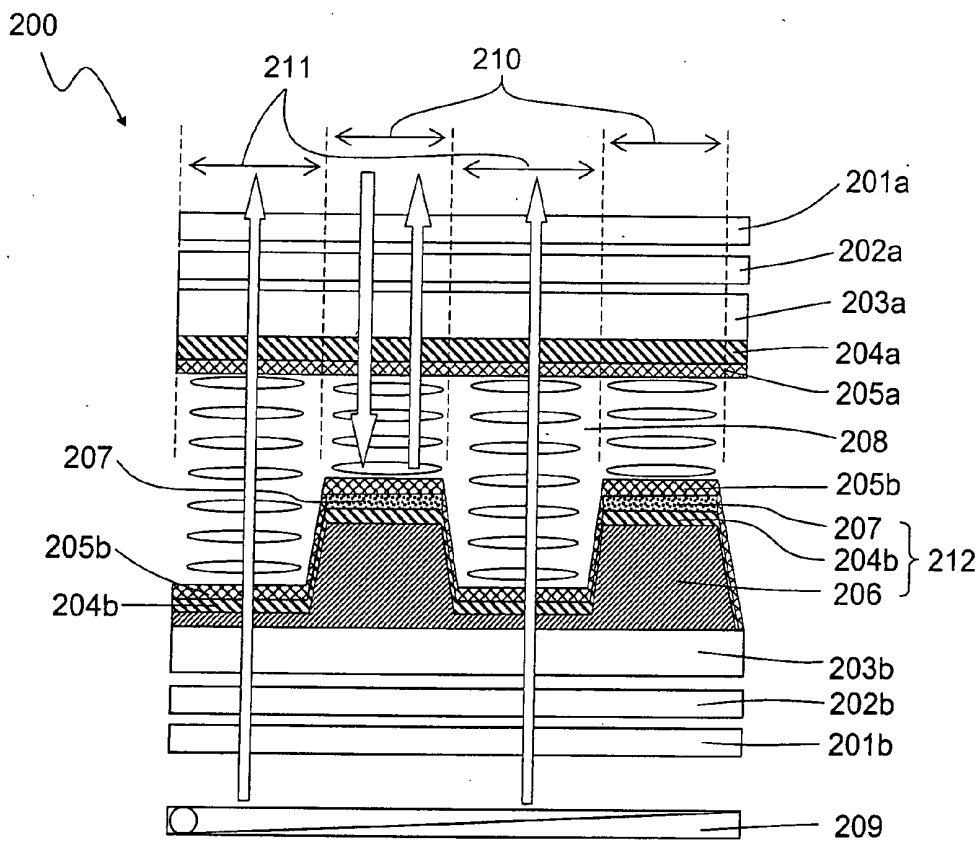

FIG. 2  
PRIOR ART

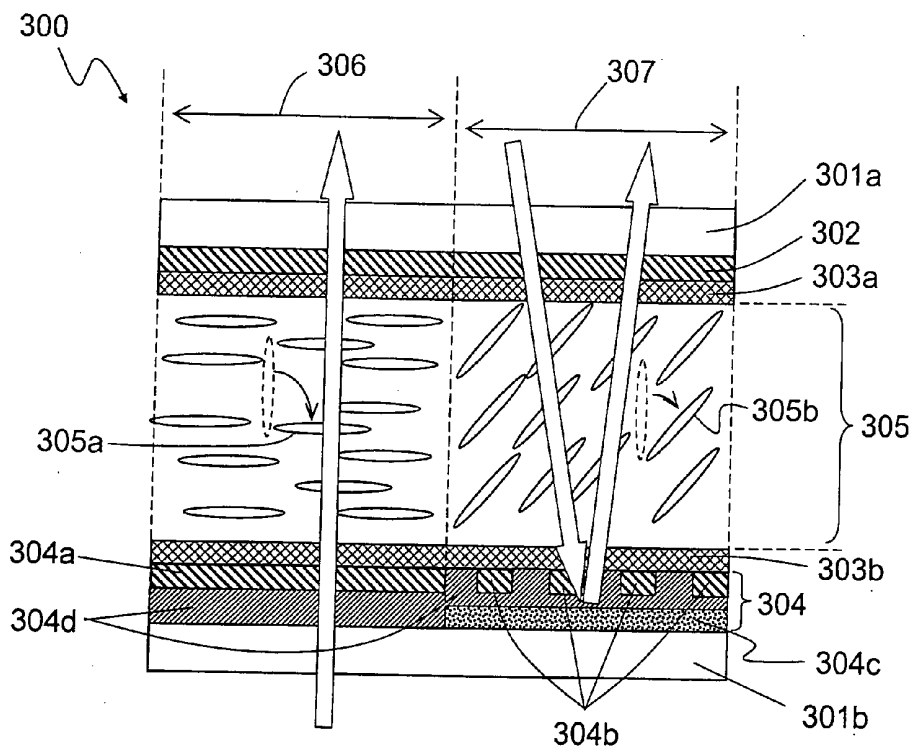

FIG. 3  
PRIOR ART

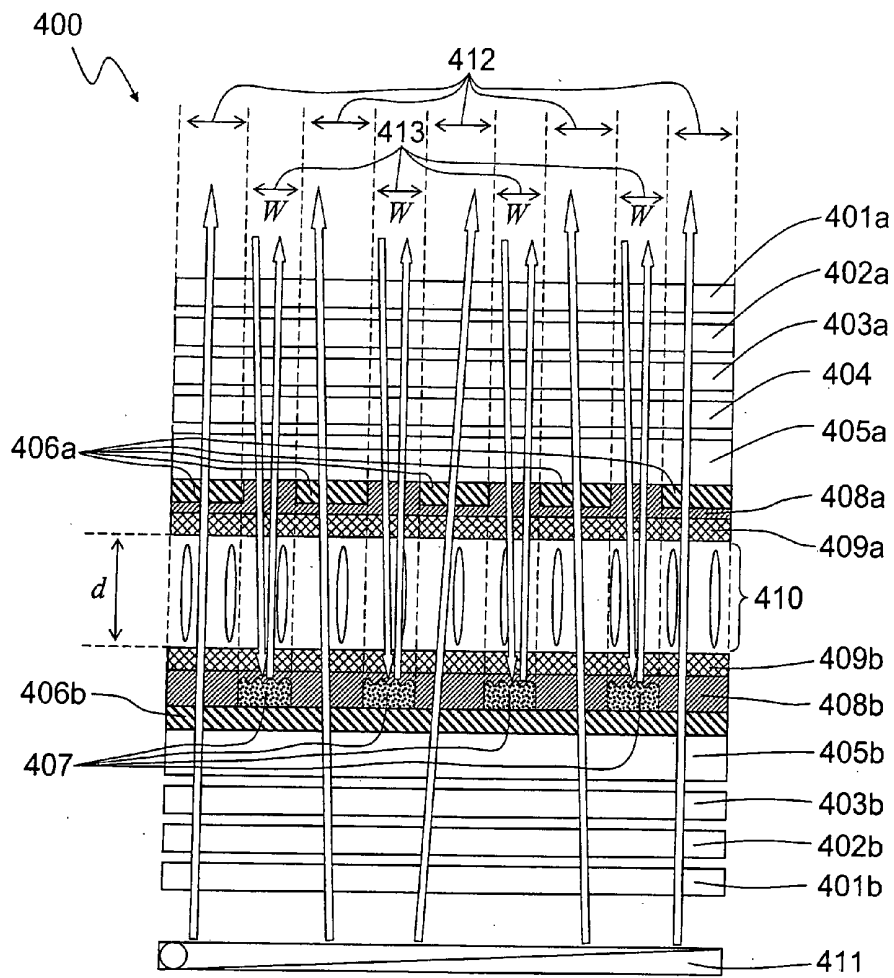

FIG. 4

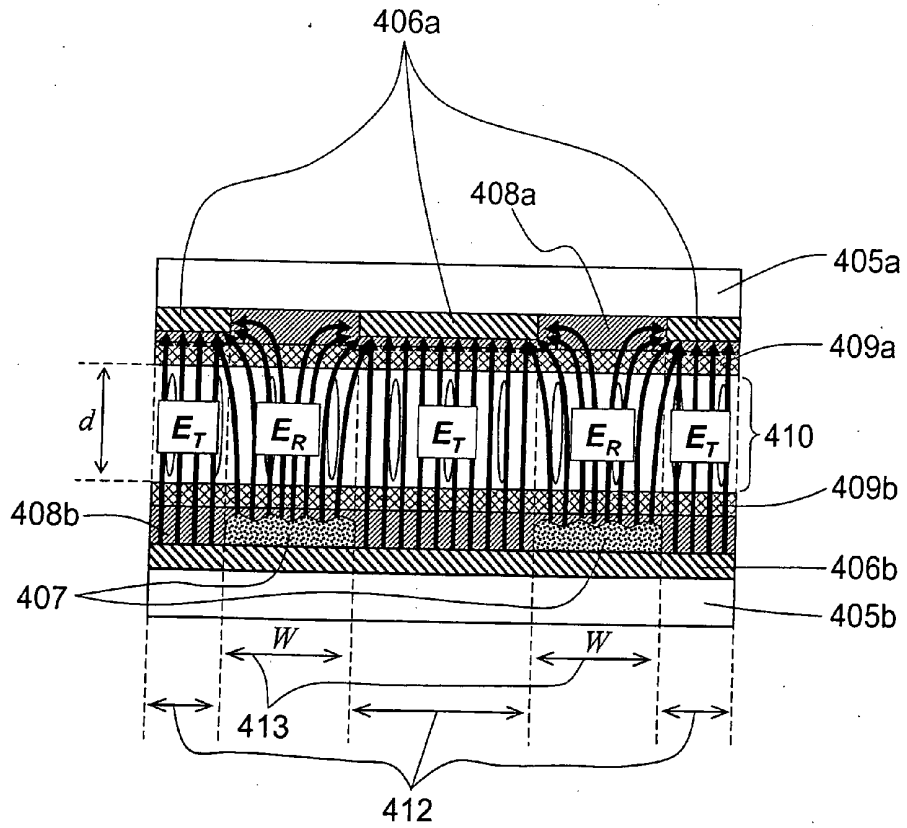

FIG 5

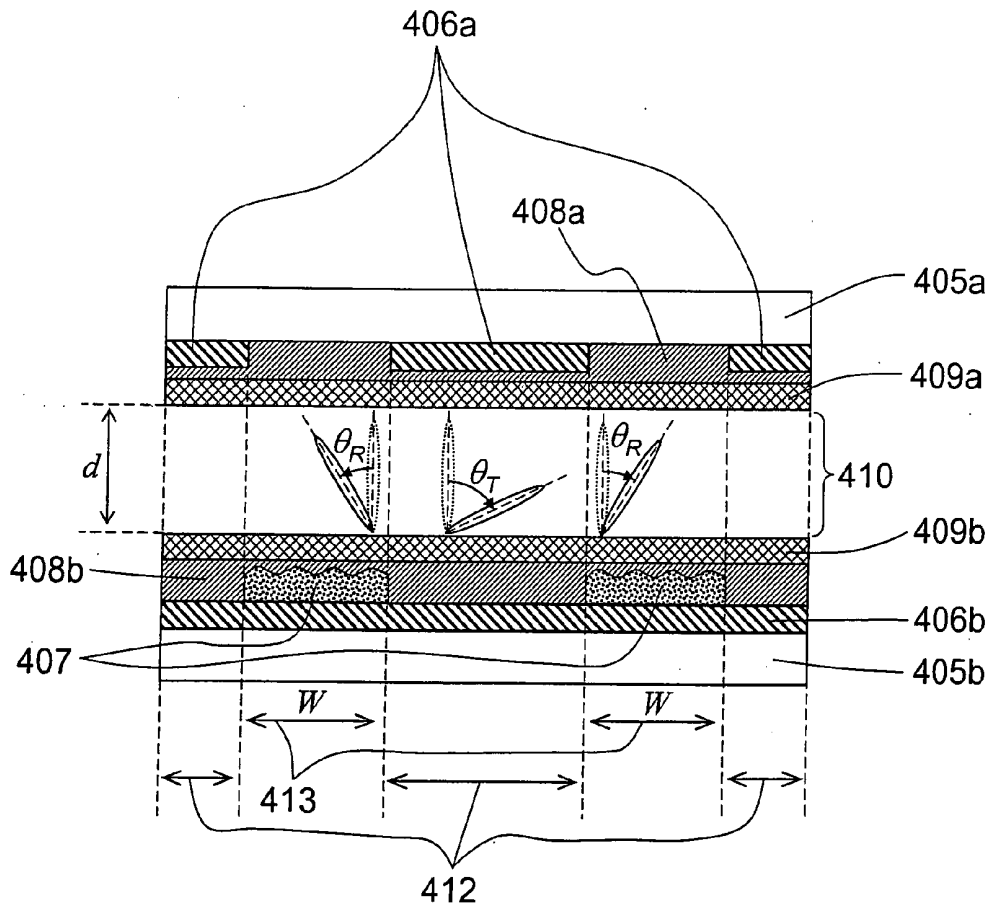

FIG 6

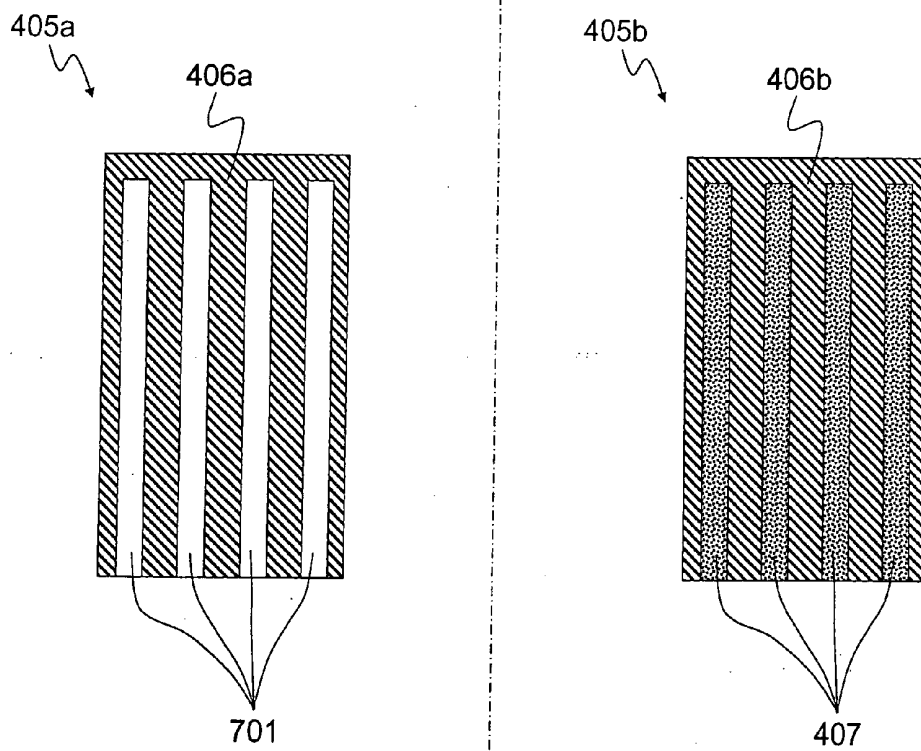

FIG. 7A

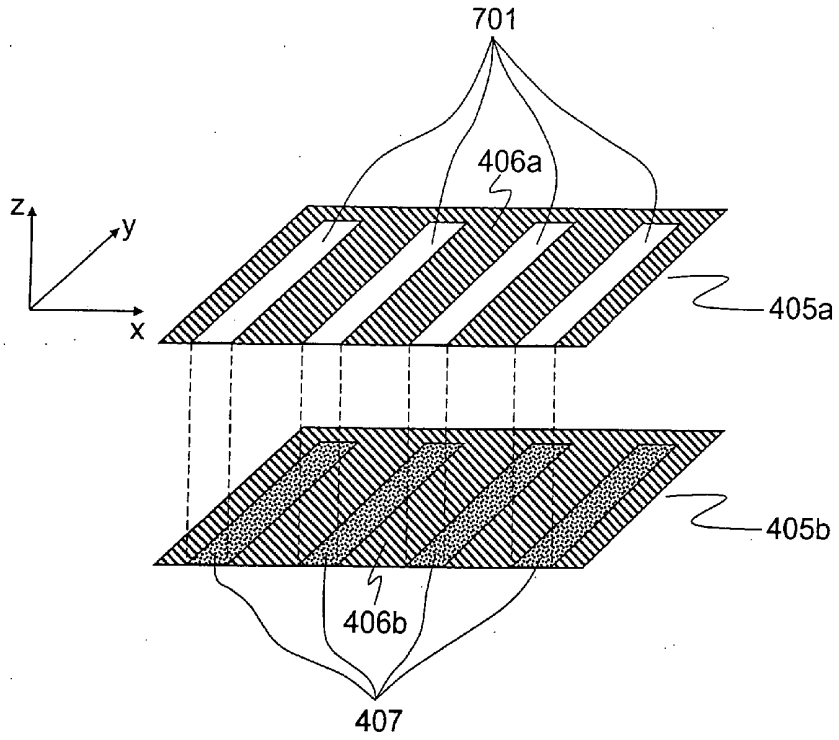

FIG 7B

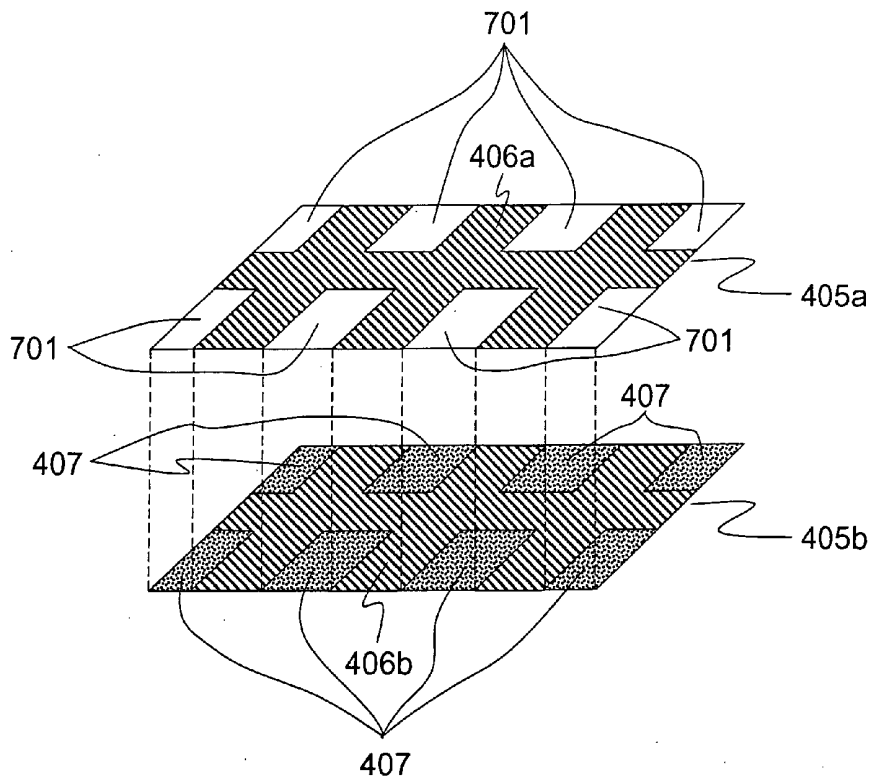

FIG 7C

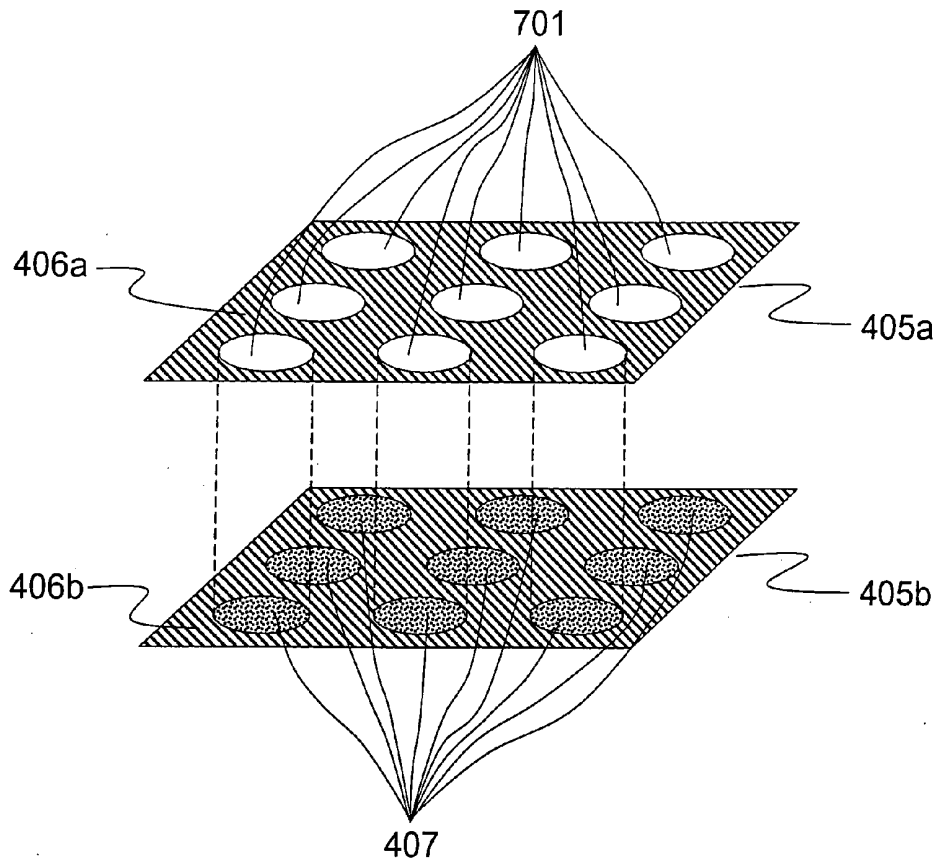

FIG. 7D

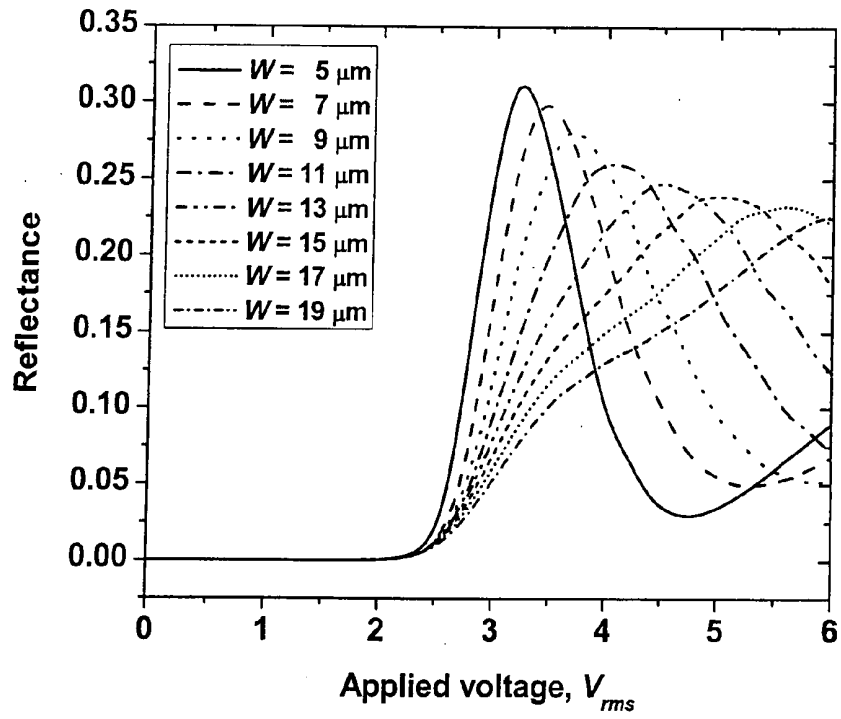

FIG 8A

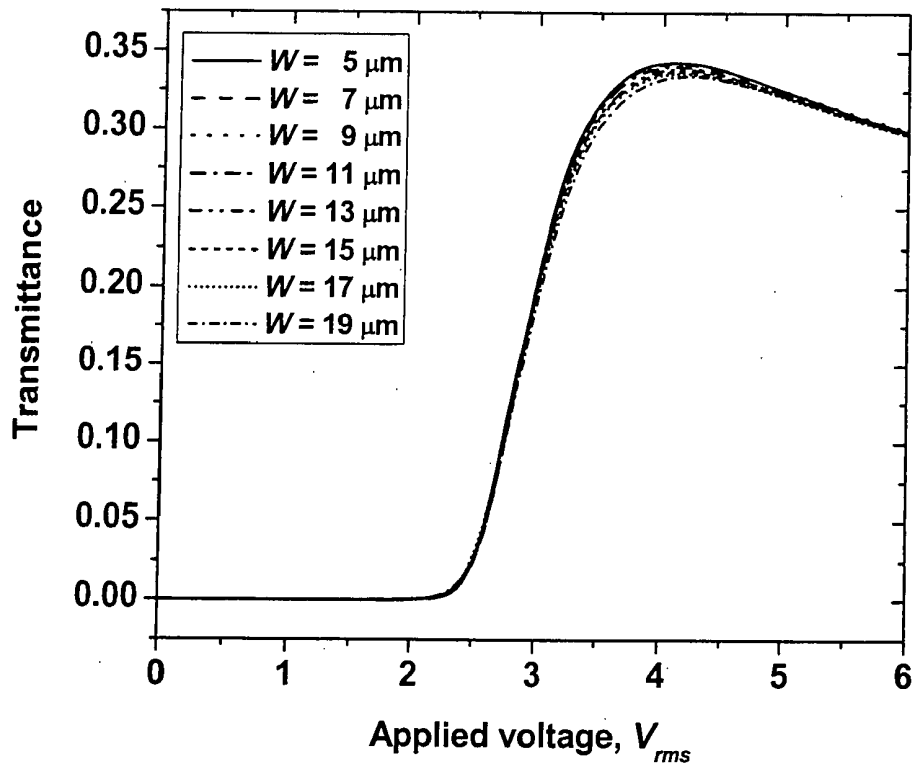

Fig. 8B

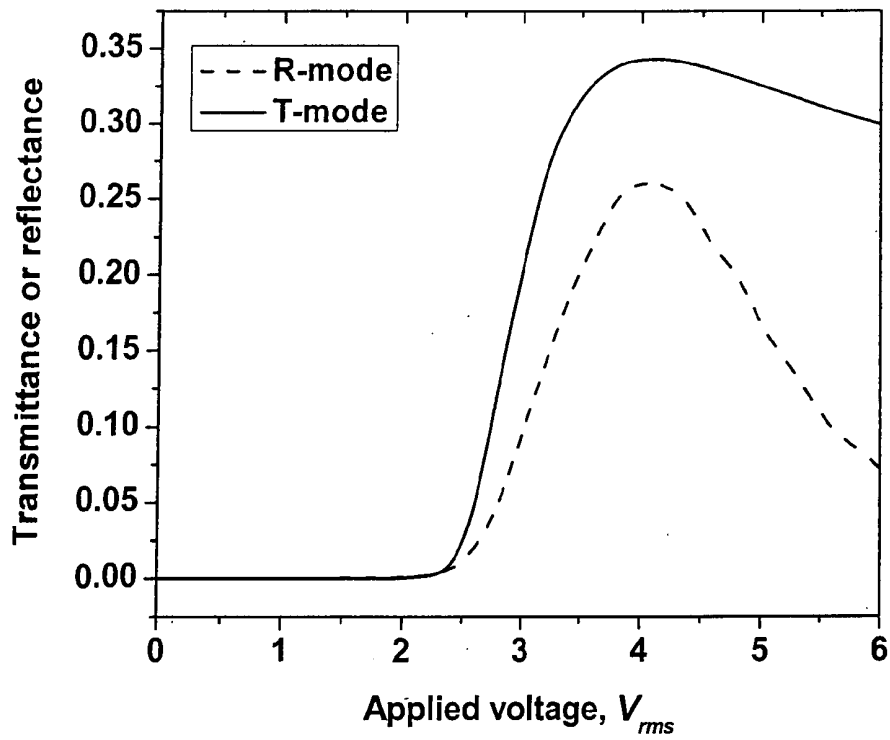

FIG. 8C

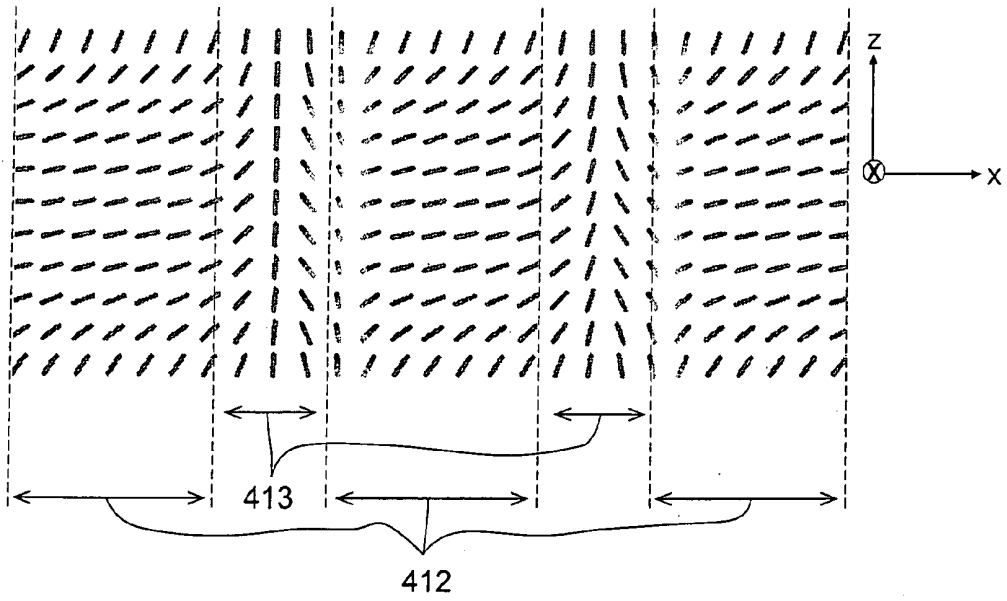

FIG 9A

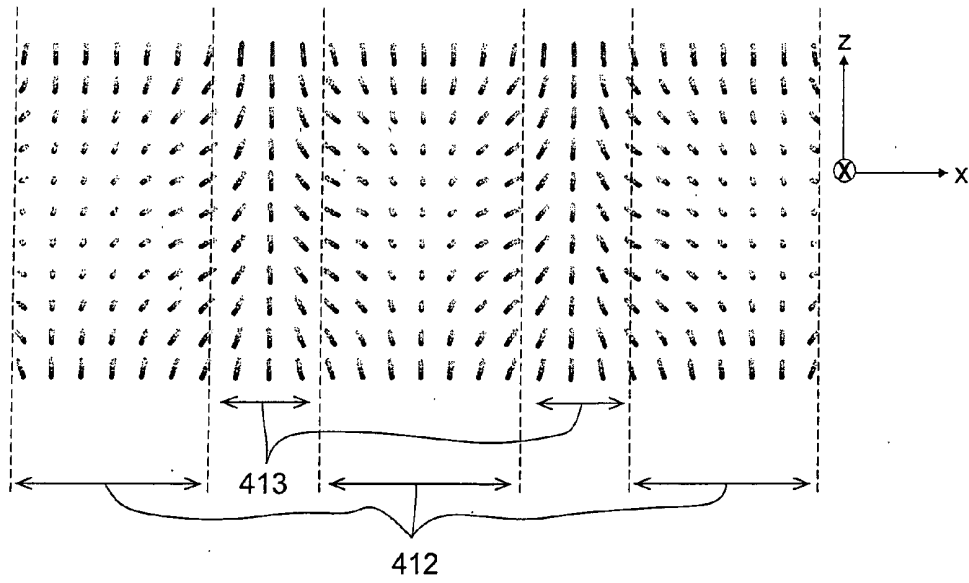

FIG. 9B

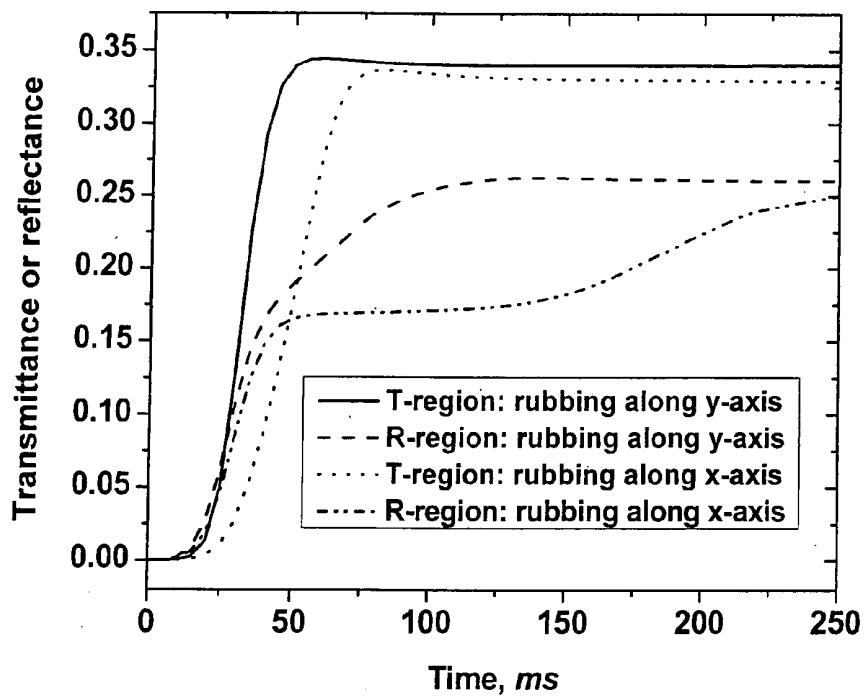

FIG 9C

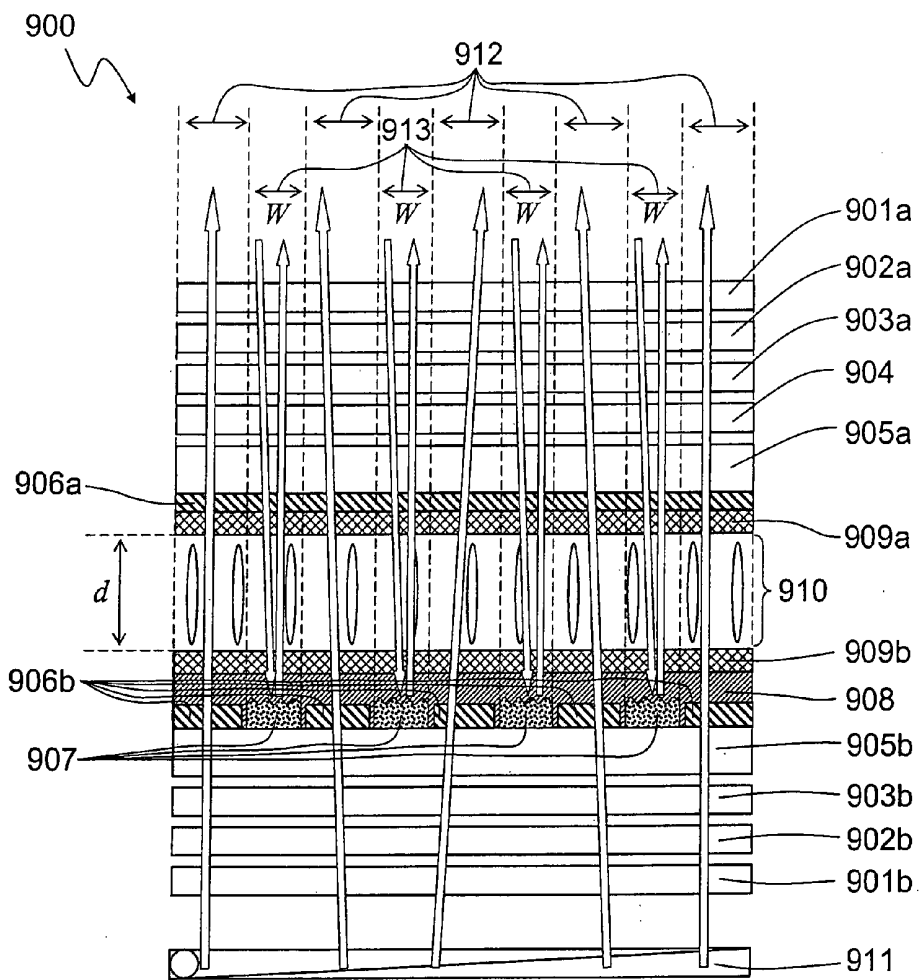

FIG 10

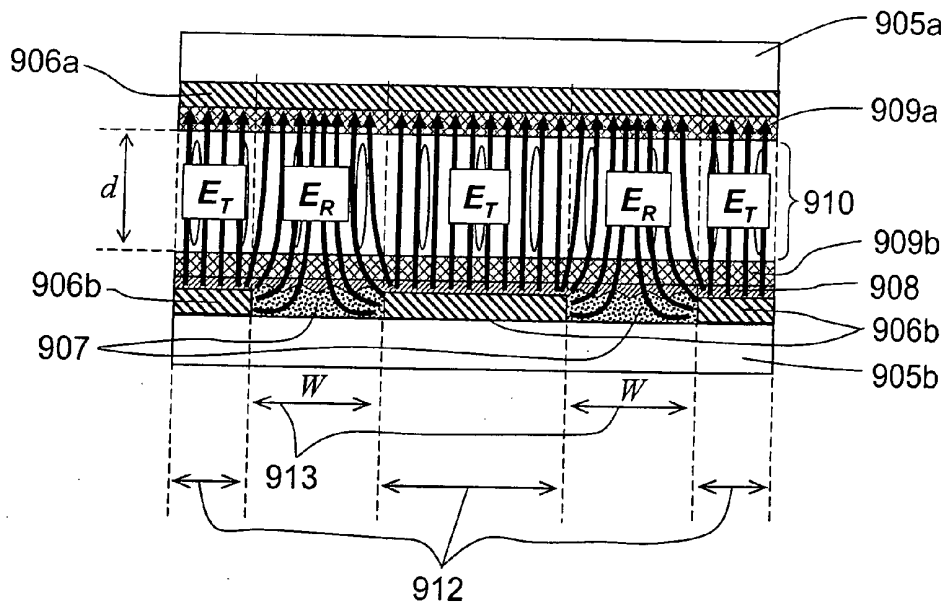

FIG 11

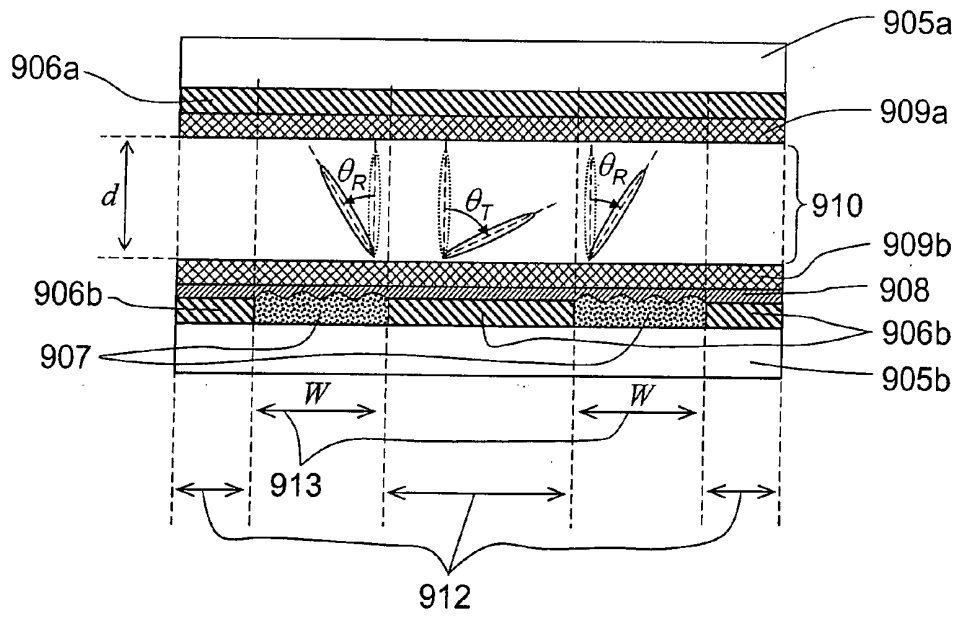

FIG 12

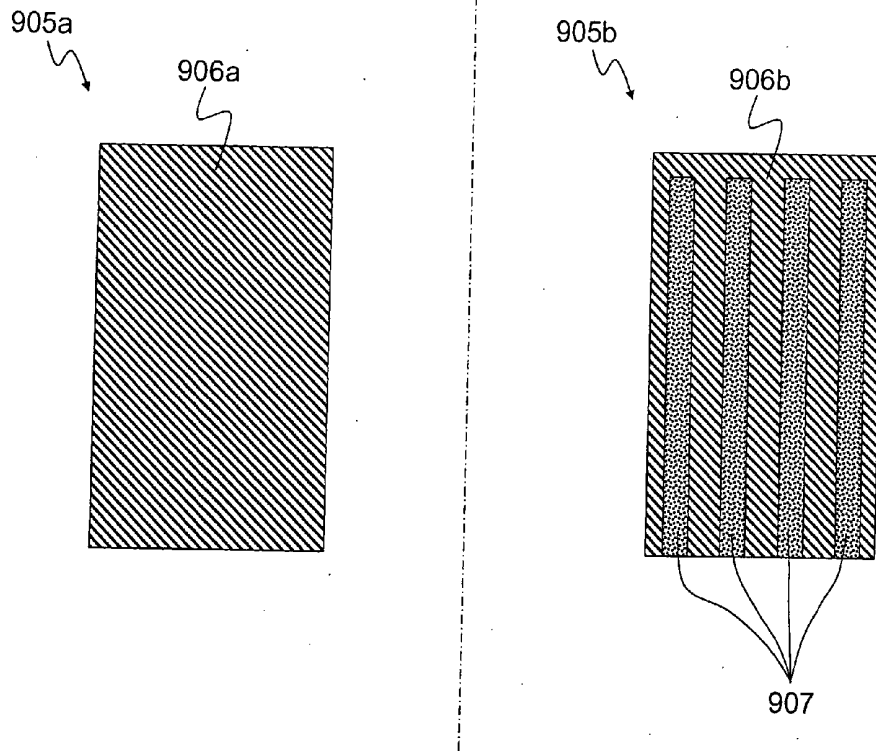

FIG. 13A

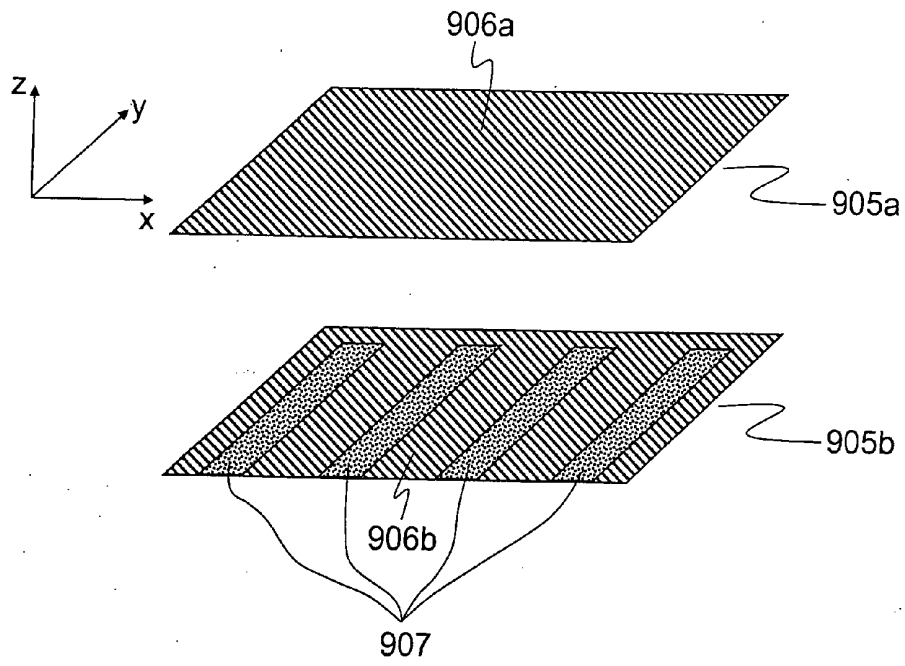

FIG 13B

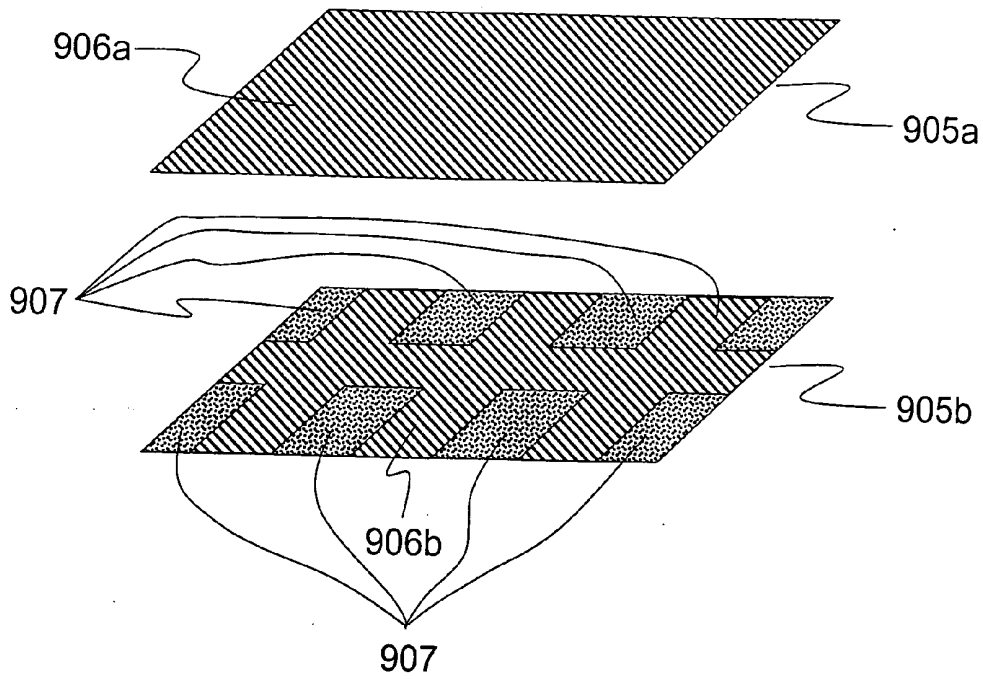

FIG 13C

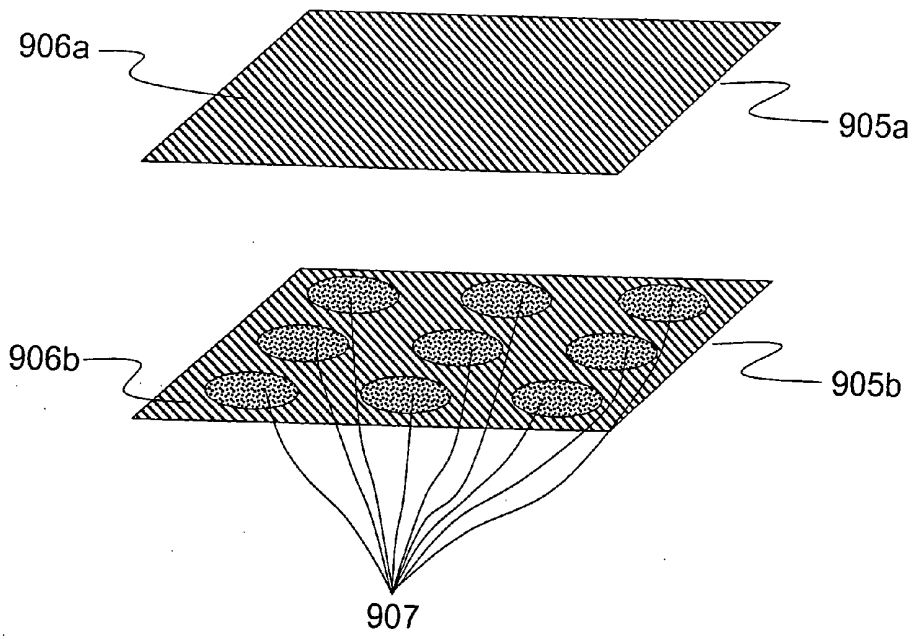

FIG. 13D

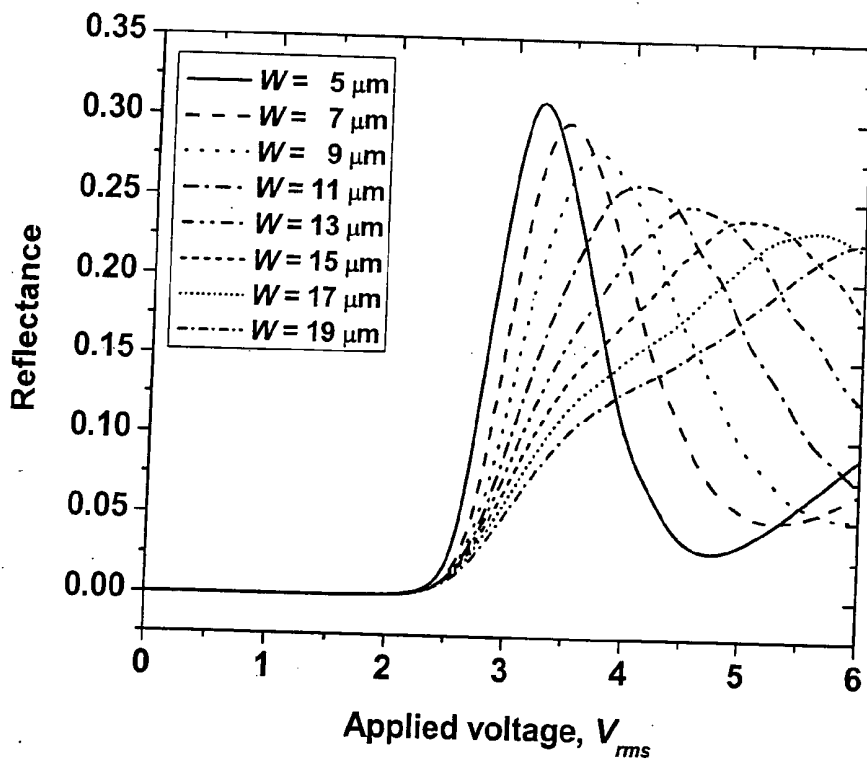

FIG. 14A

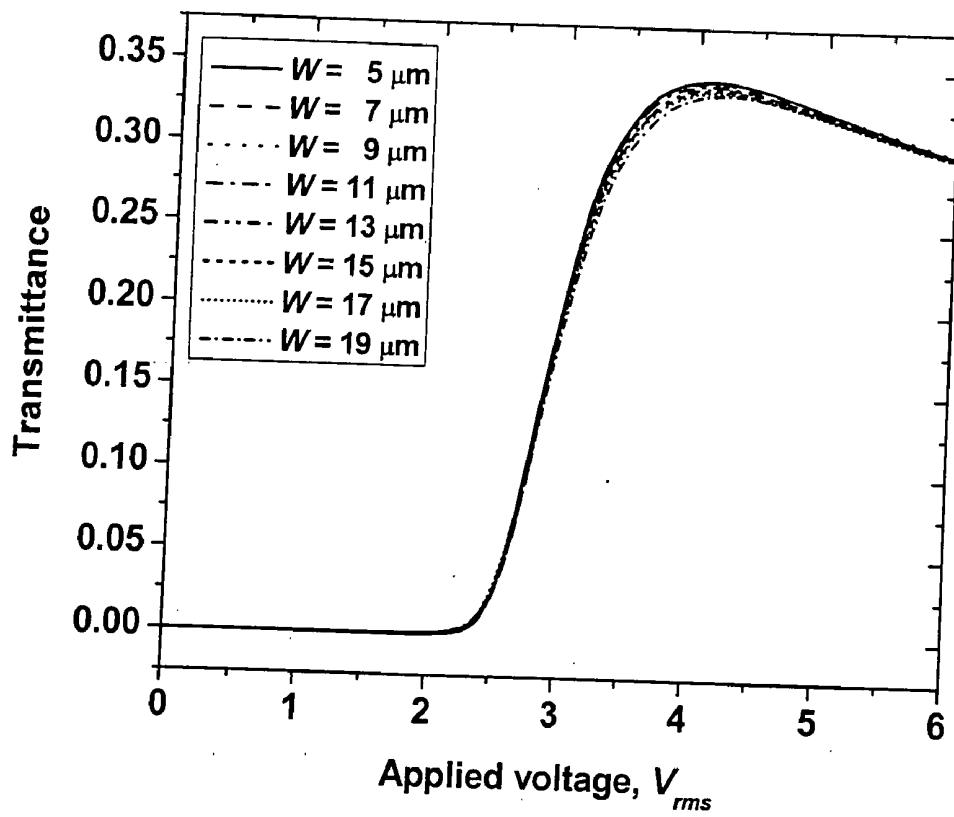

Fig. 14B

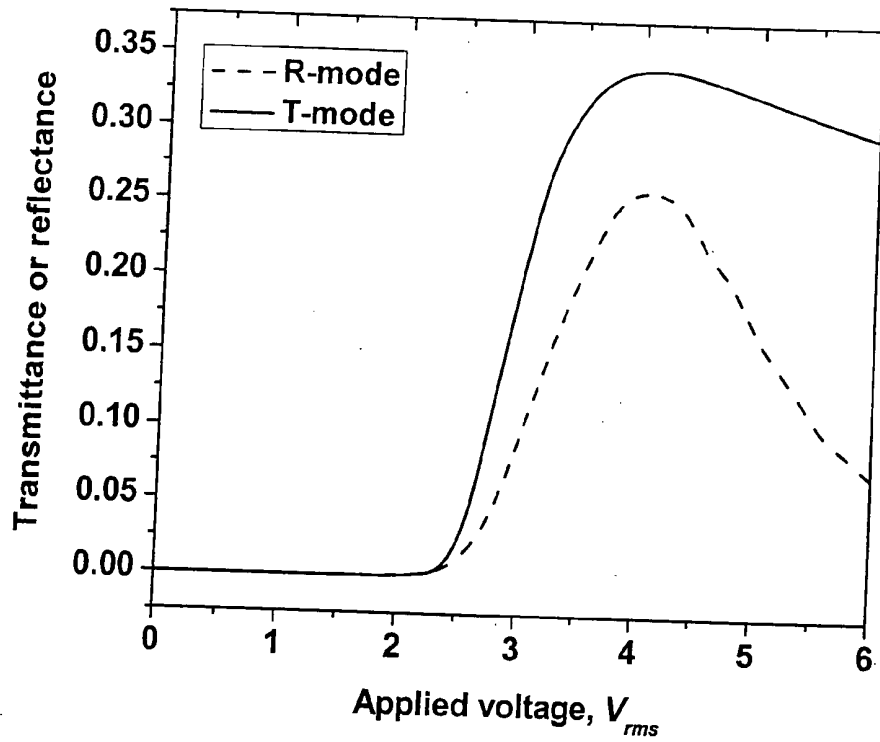

FIG. 14C

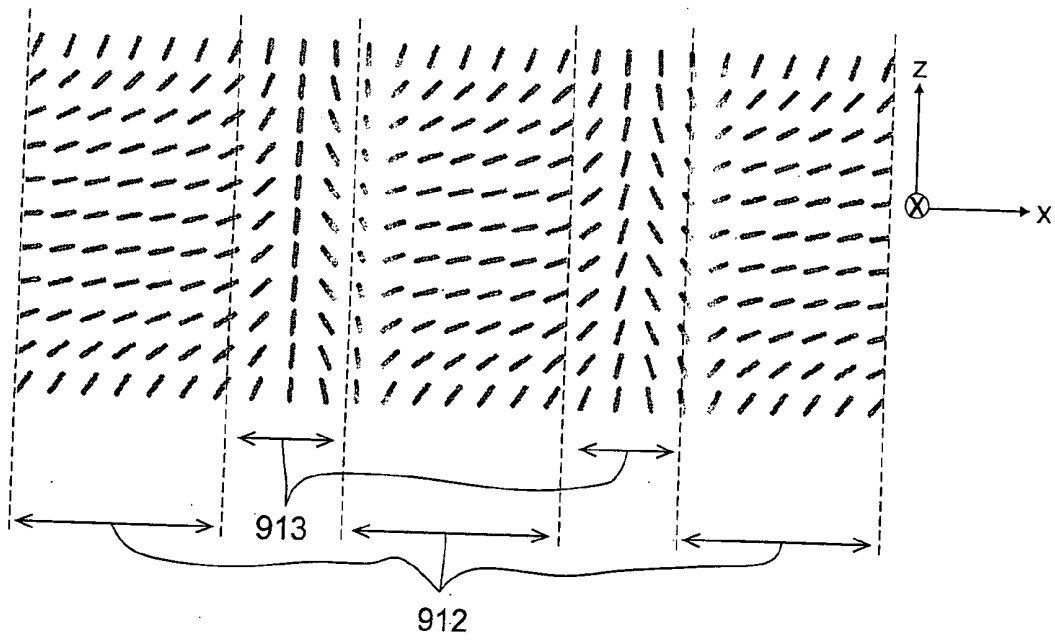

FIG 15A

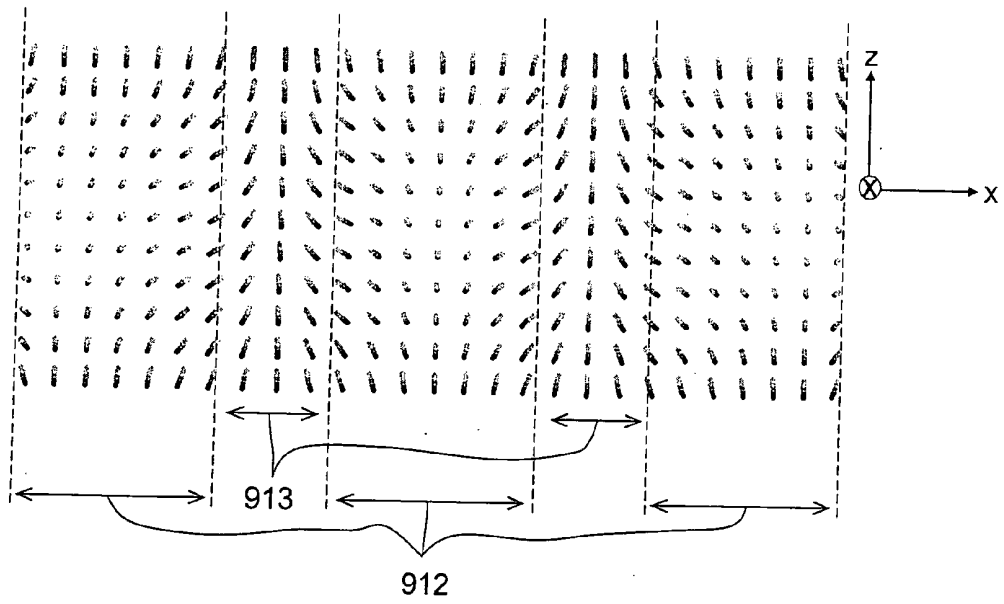

FIG 15B

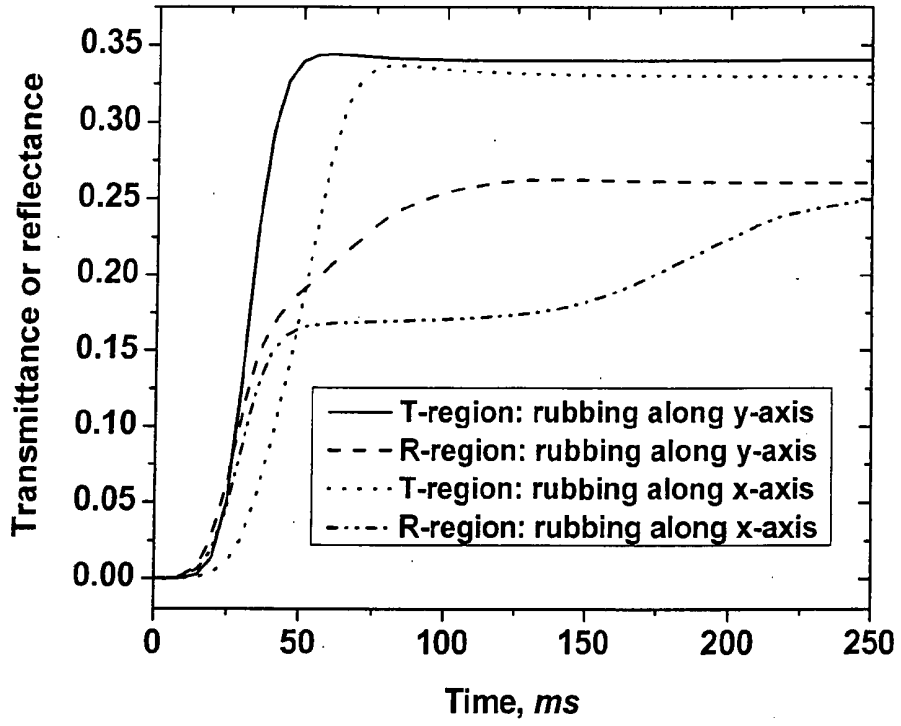

FIG. 15C

## TRANSFLECTIVE LIQUID CRYSTAL DISPLAY WITH VERTICAL ALIGNMENT

### FIELD OF THE INVENTION

[0001] This invention relates to transfective liquid crystal displays and, in particular, to designing the common electrode and the pixel electrode to generate a longitudinal electric field in the transmissive display region and to generate a fringing field in the reflective display region. Therefore, the initially vertically aligned negative dielectric anisotropic nematic liquid crystal molecules will form a smaller tilt angle with respect to the substrate normal in the reflective display region and form a larger tilt angle with respect to the substrate normal in the transmissive display region. Consequently, the ambient incident light experiences smaller phase retardation in the reflective display region while the light from the backlight source experiences larger phase retardation. Since the ambient light passes through the reflective display region twice while the light from the backlight source passes through the transmissive display region only once, by properly designing the electrodes and the reflector width, the light from both ambient light source and backlight source will experience almost the same phase retardation in both reflective and transmissive display regions. As a result, the electro-optical performance curves of both transmissive display mode and reflective display mode overlap very well.

### BACKGROUND AND PRIOR ART

[0002] Transmissive liquid crystal display (LCD) is widely used as information display tools, such as cell phone, personal digital assistant, laptop computer and so on. The most commonly used transmissive twisted-nematic (TN) LCD has a 90° TN liquid crystal layer sandwiched between two perpendicularly rubbed transparent substrates with Indium-Tin-Oxide (ITO), coatings. Two linear polarizers are placed at the outside of transparent substrates to act as a polarizer and an analyzer whose transmission directions are either parallel or perpendicular to the rubbing direction of the adjacent substrate. In addition, a backlight is put outside of the polarizer as the light source. Without voltage, the incident light becomes linearly polarized after passing through the polarizer, then follows the twist structure of TN liquid crystal layer, and finally transmits through the analyzer, resulting in a bright state. When the applied voltage exceeds the threshold voltage, the twist structure of TN liquid crystal layer is broken and the incident linear polarizer can not follow the liquid crystal twist structure; consequently, the light, in general, becomes elliptically polarized and the output transmittance decreases. If the applied voltage is high enough, the volume part of the liquid crystal molecules are approximately aligned perpendicularly to the substrates, except the crossed residual boundary liquid crystal layers. In this case, the incident linearly polarized light nearly maintains the same polarization state after passing through the entire liquid crystal layer, and then is blocked by the analyzer, resulting in a very good dark state. A major drawback of the transmissive LCD is that its backlight source should be on all the time when the display is in use; therefore, the power consumption is relatively high. Another disadvantage is that the image of transmissive LCD is easily washed out under strong ambient light conditions, such as outdoor sunlight.

[0003] Reflective LCD, on the other hand, has no built-in backlight source. Instead, it utilizes ambient light for reading the displayed images. U.S. Pat. No. 5,933,207 issued to Wu on Aug. 3, 1999 describes a reflective LCD comprising a polarizer, a phase compensation film, a liquid crystal layer, and a reflector. Compared to the transmissive LCD, the reflective LCD has advantages including low power consumption, light weight, and good outdoor readability. However, a reflective LCD relies on ambient light and thus is inapplicable under low light levels or dark ambient conditions.

[0004] To utilize the advantages, and overcome the disadvantages, of both transmissive LCD and reflective LCD, the transfective LCD is used in the apparatus, method, system, and device of the present invention. Transfective LCD means the apparatus displays an image in transmissive display mode and reflective display mode either independently or simultaneously. Therefore, such a transfective LCD is designed to be used under any ambient circumstances; U.S. Pat. No. 4,315,258 issued to McKnight et al on Feb. 9, 1982 proposed a transfective LCD design shown as 10 in FIG. 1. It consists of a front polarizer 11, a LC panel 12, a rear polarizer 13, a translector (partially transmitting mirror) 14 and a backlight source 15. Such a structure is actually modified from the conventional transmissive twisted-nematic (TN) LCD by putting a translector 14 between the rear polarizer 13 and backlight source 15. This prior art has the advantages of a simple manufacturing process and low cost; however, it suffers from serious parallax problem because the ambient light passes through a very thick glass substrate before it hits the translector. When the display device is viewed from an oblique direction, the reflected beam and input beam pass through different pixel areas, resulting in a shadowed image, which is called parallax. Such a parallax problem becomes increasingly serious when the pixel size decreases in high resolution display devices.

[0005] To overcome the parallax problem, the translector should be imbedded in the inner side of the bottom substrate. U.S. Pat. No. 6,281,952 to Okamoto et al proposed a transfective LCD design shown as 200 in FIG. 2. It consists of a top linear polarizer 201a and a bottom linear polarizer 201b, a top compensation film 202a and a bottom compensation film 202b, a top transparent substrate 203a and a bottom transparent substrate 203b, a liquid crystal layer 208 sandwiched between the top substrate 203a and the bottom substrate 203b. The top substrate 203a is coated with a transparent electrode 204a and a first alignment film 205a. The bottom substrate 203b is coated with a translector means 212, which contains a non-uniform thickness isolation layer 206, a transparent electrode 204b and a patterned reflection layer 207. The reflection layer 207 only covers the thick isolation layer region, which defines the reflective display region 210. The thin isolation layer region, which defines the transmissive region 211, is not covered with the reflection layer 207. Above the translector means 212 is a second alignment film 205b. The liquid crystal layer 208 contacts with both the first alignment film 205a and the second alignment film 205b. A backlight source 209 is provided outside of the bottom polarizer 201b to function as the light source for the transmissive display region 211. Since the translector means 212 was deposited inside of the bottom substrate 203b, the reflected beam does not pass through the very thick bottom substrate 203b; therefore, the

parallax problem is eliminated. In addition, in order to compensate the optical path difference between the reflective and transmissive display modes, the cell gap in transmissive display region **211** is thicker than that in reflective display region **210** or the director alignment mechanism in transmissive display region **211** is different from that in reflective display region **210**. Nevertheless, in either case, the manufacturing process is quite complicated and hence the manufacturing cost is relatively high. Another drawback of the different cell gap approach is that the response time in reflective region **210** is different from that in transmissive region **211** since the response time is proportional to the square of cell gap. Furthermore, the different cell gap or different alignment for transmissive and reflective display regions will introduce a disclination line on the border of two regions, which leads to dark state light leakage and thus degraded contrast ratio of the displayed image.

[0006] To solve the cell gap difference problem while keeping parallax-free in transmissive CD, US patent application No. 20030202139 by Choi et al disclosed a transmissive LCD design with partial switching method shown as **300** in FIG. 3. It consists of a top substrate **301a** coated with a top transparent electrode **302** and an alignment film **303a**, a bottom substrate **301b** coated with a translector means **304** and an alignment film **303b**, and a liquid crystal layer **305** sandwiched between the top substrate **301a** and bottom substrate **301b**. The translector means **304** is composed of a non-patterned (continuous) transparent electrode **304a**, a patterned (discontinuous) transparent electrode **304b**, a reflector **304c** below the patterned transparent electrode **304b**, and an insulating layer **304d**. The non-patterned transparent electrode **304a** area defines the transmissive display region **306**, while the reflector **304c** area defines the reflective display region **307**. The non-patterned transparent electrode **304a** and the patterned transparent electrode **304b** are connected with each other and they have the same electric potential. The electric field between top transparent electrode **302** and bottom non-patterned transparent electrode **304a** is strong and almost perpendicular to the substrates **301a** and **301b**. Such a strong electric field drives the liquid crystal molecules **305a** to almost fully tilted as shown in FIG. 3. While the electric field between top transparent electrode **302** and bottom patterned transparent electrode **304b** is a fringing field and its overall strength is weaker than the field above the non-patterned transparent electrode **304a**. Such a weak fringing field only drives the liquid crystal molecules **305b** partially tilted.

[0007] Therefore, the phase retardation in reflective region is approximately half of that in transmissive region. However, since the reflector **304c** should be located under the discontinuous electrode **304b**, the insulating layer **304d** is inevitable, which increase the manufacturing process. To avoid use of an insulating layer **304d**, the discontinuous electrode **304b** can be coated on the top substrate **301a**. In either case, however, the weak electrical field only exists between the discontinuous electrode gap and the common electrode **302**, while the electrical field right above the discontinuous electrode **304b** is still as strong as that in transmissive region **306**. In other words, not the whole reflective display region is governed by fringing field. Consequently, the local region liquid crystal molecules above the discontinuous electrode **304b** are still full-tilted as in transmissive region **306**. Therefore, the gray scale of reflective

and transmissive display modes still does not overlap very well, as shown in FIG. 6 of US patent application 20030202139.

#### SUMMARY OF THE INVENTION

[0008] A first objective of this invention is to provide a new transmissive LCD with uniform cell gap throughout the transmissive region and reflective region to simplify the manufacturing process and lower the manufacturing cost.

[0009] A second objective of the invention is to provide a new transmissive LCD with mutually complementary patterned reflector and patterned common electrode such that the transmissive display region is governed by a longitudinal electric field, while the reflective display region is governed by a fringing field. Therefore, the grayscales of both the reflective mode and the transmissive mode effectively overlap when the pattern size and pattern gap are properly designed.

[0010] A third objective of the invention is to provide a new transmissive LCD with uniform alignment treatment in both transmissive and reflective regions using mutually complementary reflector pattern and the common electrode pattern, which make the electric field in the reflective display region weaker than that in the transmissive display region to eliminate the disclination line that occurs in the dual cell gap method of the prior art.

[0011] A fourth objective of the invention is to provide a new transmissive LCD with high contrast ratio and high brightness

[0012] A fifth objective of the invention is, to provide a new method of constructing approximately mutually complementary reflector pattern on the bottom substrate and common electrode pattern on the top substrate in the transmissive LCD to ensure that the reflective display region is governed by a fringing field while the transmissive display region is governed by a longitudinal electric field.

[0013] In the reflective display mode, the ambient light travels through the reflective region twice, while in the transmissive display mode, the backlight passed through transmissive region only once. Thus, there is approximately twice the difference in the overall optical path between the transmissive and reflective regions. To make a transmissive LCD with uniform cell gap throughout both reflective and transmissive regions, the phase retardation in reflective region should be half that of transmissive region at any applied voltage state so that the gray scales of both the reflective mode and transmissive mode can overlap effectively.

[0014] In the apparatus, method, system and device of the present invention, a transmissive LCD with a mutually complementary common electrode pattern and reflector pattern is disclosed. The translector is deposited on the bottom substrate and is composed of a non-patterned transparent electrode coated with patterned reflector. As a result, the area without patterned reflector coverage is transparent, while the area with patterned reflector coverage is opaque and reflects incident light. The opaque area defines the reflective display region, while the transparent area defines the transmissive display region. The non-patterned transparent electrode can be made of Indium-Tin-Oxide (ITO) and the patterned reflector is directly deposited above the non-patterned trans-

parent electrode. The patterned reflector can be made of high reflectivity conductive metal materials, such as aluminum, aluminum alloy, silver, and so on. In addition, the patterned reflector can also be fabricated from some nonconductive materials, such as high reflectivity multilayer dielectric thin films. Since the patterned reflector and the non-patterned transparent electrode are connected together, no additional insulating layer is necessary between them. If the patterned reflector is made of conductive metallic materials, then both the non-patterned transparent electrode and the patterned reflector function as the pixel electrode. On the other hand, if the patterned reflector is made of nonconductive materials, then only the non-patterned transparent electrode functions as the pixel electrode.

[0015] The top substrate side is coated with a patterned transparent common electrode. The common electrode pattern is approximately mutually complementary with the reflector pattern on the bottom substrate. As a result, there is no common electrode above the reflector coverage, while there is common electrode above the transparent pixel electrode area without the reflector coverage. Such a mutually complementary reflector pattern and common electrode pattern configuration ensures that the transmissive display region is governed by a longitudinal electric field, while the reflective display region is governed by a fringing field. Therefore, the electric field in the reflective display region is weaker than that in the transmissive display region. By properly designing the pattern size and pattern gap, the single pass phase retardation in the reflective display region can be approximately half the single pass phase retardation in the transmissive display region at any applied voltage state. Because the ambient incident light passes through the reflective display region twice while backlight incident light passes through the transmissive display region only once, the grayscales of the reflective display mode effectively overlap those of the transmissive display mode.

[0016] Further objects and advantages of this invention will be apparent from the following detailed description of preferred embodiments which are illustrated schematically in the accompanying drawings.

#### BRIEF DESCRIPTION OF THE FIGURES

[0017] FIG. 1 is a schematic structure of a prior art transmissive LCD.

[0018] FIG. 2 is a schematic structure of another prior art transmissive LCD.

[0019] FIG. 3 is a schematic structure of yet another prior art transmissive LCD.

[0020] FIG. 4 is a schematic structure of the transmissive LCD in this invention according to the first embodiment.

[0021] FIG. 5 illustrates the electric field distribution in both the transmissive display region and reflective display region according to the first embodiment.

[0022] FIG. 6 illustrates the director distribution in both transmissive display region and reflective display region under the electric field distribution shown in FIG. 5.

[0023] FIG. 7A is a top view of a first example of the mutually complementary common electrode pattern on the first substrate and reflector pattern on the second substrate corresponding to the embodiment shown in FIG. 4.

[0024] FIG. 7B shows the oblique view of the first example of the mutually complementary common electrode pattern on the first substrate and reflector pattern on the second substrate corresponding to the embodiment shown in FIG. 4.

[0025] FIG. 7C shows the oblique view of a second example of the mutually complementary common electrode pattern on the first substrate and reflector pattern on the second substrate corresponding to the embodiment shown in FIG. 4.

[0026] FIG. 7D shows the oblique view of a third example of the mutually complementary common electrode pattern on the first substrate and reflector pattern on the second substrate corresponding to the embodiment shown in FIG. 4.

[0027] FIG. 8A is a graph of the voltage dependent reflectance curve of the first embodiment of this invention with cell gap  $d=5\ \mu\text{m}$  and different reflector width  $W$  as shown in FIG. 4.

[0028] FIG. 8B is a graph of the voltage dependent transmittance curve of the first embodiment of this invention with cell gap  $d=5\ \mu\text{m}$  and different reflector width  $W$  as shown in FIG. 4.

[0029] FIG. 8C is a graphical comparison of the voltage dependent transmittance and reflectance curves of the first embodiment of this invention with cell gap  $d=5\ \mu\text{m}$  and the reflector width  $W=11\ \mu\text{m}$  as shown in FIG. 4.

[0030] FIG. 9A is a sectional view of the equilibrium state director distribution with the strip electrode design of FIG. 7B when rubbing direction is along x-axis direction.

[0031] FIG. 9B is a sectional view of the equilibrium state director distribution with the strip electrode design of FIG. 7B when rubbing direction is along y-axis direction.

[0032] FIG. 9C is a graph illustrating the rise period dynamic response for different rubbing direction cases in the first embodiment of the invention.

[0033] FIG. 10 shows the schematic structure of the transmissive LCD according to a second embodiment of the invention.

[0034] FIG. 11 shows the electric field distribution in both transmissive display region and reflective display region corresponding to the second embodiment.

[0035] FIG. 12 shows the director distribution in both transmissive display region and reflective display region under the electric field distribution shown in FIG. 11.

[0036] FIG. 13A shows the top view of a first example of the mutually complementary ITO electrode pattern and reflector pattern on the second substrate according to the second embodiment of the present invention.

[0037] FIG. 13B shows the oblique view of the first example of the mutually complementary ITO electrode pattern and reflector pattern on the second substrate according to the second embodiment.

[0038] FIG. 13C shows the oblique view of a second example of the mutually complementary ITO electrode pattern and reflector pattern on the second substrate according to the second embodiment of the present invention.

[0039] FIG. 13D shows the oblique view of a third example of the mutually complementary ITO electrode pattern and reflector pattern on the second substrate in the second embodiment of the present invention.

[0040] FIG. 14A is a graph illustrating the voltage dependent reflectance curve of corresponding to the second embodiment of the invention with cell gap  $d=5 \mu\text{m}$  and different reflector width  $W$  as shown in FIG. 10.

[0041] FIG. 14B is a graph illustrating the voltage dependent transmittance curve of the second embodiment of the invention with cell gap  $d=5 \mu\text{m}$  and different reflector width  $W$  as shown in FIG. 10.

[0042] FIG. 14C is a graphical comparison of the voltage dependent transmittance and reflectance curves of the second embodiment of the invention with cell gap  $d=5 \mu\text{m}$  and the reflector width  $W=11 \mu\text{m}$  as shown in FIG. 10.

[0043] FIG. 15A illustrates a section view of the equilibrium state director distribution with the strip electrode design of FIG. 13B when rubbing direction is along x-axis direction.

[0044] FIG. 15B illustrates a section view of the equilibrium state director distribution with the strip electrode design of FIG. 13B when rubbing direction is along y-axis direction.

[0045] FIG. 15C is a graph showing the rise period dynamic response for different rubbing direction cases according to the second embodiment.

DESCRIPTION OF THE PREFERRED EMBODIMENTS

[0046] Before explaining the disclosed embodiments of the present invention in detail it is to be understood that the invention is not limited in its application to the details of the particular arrangements shown since the invention is capable of other embodiments. Also, the terminology used herein is for the purpose of description and not of limitation.

[0047] The following is a list of the reference numbers used in the drawings and the detailed specification to identify components:

10	transflective LCD design (U.S. Pat. No. 4,315,258)
11	front polarizer
12	LC panel
13	rear polarizer
14	transflector
15	backlight source
200	transflective LCD design (U.S. Pat. No. 6,281,952)
201a	top linear polarizer
201b	bottom linear polarizer
202a	top compensation film
202b	bottom compensation film
203a	top transparent substrate
203b	bottom transparent substrate
204a	transparent electrode
204b	transparent electrode
205a	first alignment film
205b	second alignment film
206	isolation layer
207	reflection layer
208	liquid crystal layer

-continued

209	backlight source
210	reflective display region
211	transmissive display region
212	transflector means
300	transflective LCD w/partial switching (US Patent Application No. 20030202139)
301a	top substrate
301b	bottom substrate
302	transparent electrode
303a	alignment film
303b	alignment film
304	transflector means
304a	non-patterned transparent electrode
304b	patterned transparent electrode
304c	reflector
304d	insulating layer
305	liquid crystal layer
305a	liquid crystal molecules
305b	liquid crystal molecules
306	transmissive region
307	reflective region
400	transflective LCD, the first embodiment of the present invention
401a	first polarizer
401b	second polarizer
402a	first half-wave retardation film
402b	second half-wave retardation film
403a	first quarter-wave retardation film
403b	second quarter-wave retardation film
404	negative birefringence c-film
405a	first transparent substrate
405b	second transparent substrate
406a	patterned ITO layer
406b	non-patterned ITO layer
407	patterned reflector
408a	first non-conductive planar layer
408b	second non-conductive planar layer
409a	first vertical alignment film
409b	second vertical alignment film
410	vertically aligned negative dielectric anisotropic nematic LC layer
411	backlight source
412	transmissive display region
413	reflective display region
701	empty area
900	transmissive LCD, the second embodiment of the present invention
901a	first polarizer
901b	second polarizer
902a	first half-wave retardation film
902b	second half-wave retardation film
903a	first quarter-wave retardation film
903b	second quarter-wave retardation film
904	negative birefringence c-film
905a	first transparent substrate
905b	second transparent substrate
906a	non-patterned ITO layer
906b	patterned ITO layer
907	patterned reflector
908	non-conductive planar layer
909a	first vertical alignment film
909b	second vertical alignment film
910	vertically aligned negative dielectric anisotropic nematic liquid crystal layer
911	backlight source
912	transmissive display region
913	reflective display region

[0048] The apparatus, method, system and device of the present invention discloses a common electrode and pixel electrode design for producing a transflective LCD having a

uniform cell gap configuration. In the transfective LCD, the light from the backlight source passes through the liquid crystal layer once in transmissive display region while the ambient light passes through the liquid crystal layer twice in reflective display region. Both the backlight source input light and the ambient incident light must experience almost the same phase retardation after passing through liquid crystal layer to achieve overlapping grayscales of both reflective display mode and transmissive display mode. To achieve the overlap, the transfective LCD is designed with (1) a mutually complementary common electrode pattern and reflector pattern or (2) a mutually complementary transparent pixel electrode pattern and opaque reflector pattern such that the electric field in the transmissive region is basically longitudinal and substantially perpendicular to both top and bottom substrates, while the electric field in reflective display region is a fringing field, whose longitudinal component is approximately half the strength of that in the transmissive display region.

#### Embodiment 1

[0049] FIG. 4 shows the structure of a first embodiment of the transfective LCD 400 with uniform cell gap configuration of the present invention which consists of a first transparent substrate 405a coated with a patterned ITO layer 406a, a first non-conductive planar layer 408a, and a first vertical alignment film 409a; a second transparent substrate 405b coated with a non-patterned ITO layer 406b, a patterned reflector 407, a second non-conductive planar layer 408b, and a second vertical alignment film 409b; and a vertically aligned negative dielectric anisotropic nematic liquid crystal layer 410 with thickness  $d$  sandwiched between the first vertical alignment film 409a and the second vertical alignment film 409b.

[0050] A negative birefringence c-film 404, a first quarter-wave retardation film 403a, a first half-wave retardation film 402a, and a first polarizer 401a are further laminated on the outer surface of the first substrate 405a, wherein the negative birefringence c-film 404 contacts with the first substrate 405a and the first polarizer 401a faces the observer. A second quarter-wave retardation film 403b, a second half-wave retardation film 402b, and a second polarizer 401b are laminated on the outer surface of the second substrate 405b. In addition, a backlight source 411 is further provided outside of the second polarizer 401b. In this configuration, the patterned reflector 407 can be made of high reflectivity conductive metal materials, such as aluminum, aluminum alloy, silver and so on. In addition, the patterned reflector 407 can be made of some nonconductive materials, such as high reflectivity multilayer dielectric thin films. In either case, an additional insulating layer is not required between the patterned reflector 407 and the non-patterned transparent electrode 406b. If the patterned reflector 407 is made of conductive metal materials, then both non-patterned transparent electrode 406b and patterned reflector 407 function as the pixel electrode and have the same electric potential. On the other hand, if the patterned reflector 407 is made of nonconductive materials, then only the non-patterned transparent electrode 406b functions as the pixel electrode.

[0051] The hollow arrows in FIG. 4 represent the propagation directions of both ambient light and backlight source. The non-patterned ITO layer 406b is further connected with the drain electrode of the thin-film transistor (TFT), which

is not shown. For purpose of illustration, FIG. 4 only shows the basic structure of one pixel area of the whole transfective LCD. Other elements, such as the TFT, color filter, storage capacitor, data line, and gate line, although necessary to drive the display device, are not shown. The area of the non-patterned ITO layer 406b with patterned reflector 407 coverage is defined as the reflective display region 413, while the area of the non-patterned ITO layer 406b without patterned reflector 407 coverage is defined as the transmissive display region 412. More importantly, the patterned ITO layer 406a, which serves as the common electrode, is approximately mutually complementary with the patterned reflector 407. This means that the top patterned ITO layer 406a only covers the transmissive display region 412 and does not cover the reflective display region 413. Therefore, the electric field in the transmissive display region 412 is different from that in the reflective display region 413.

[0052] FIG. 5 shows the electric field distribution in the transmissive display region 412 and the reflective display region 413 of one pixel area. Since the top patterned ITO layer 406a only approximately covers the transmissive display region 412 and does not cover the reflective display region 413, the electric field in the transmissive display region 412 is a uniform longitudinal field  $E_T$ , which is perpendicular to the first substrate 405a and the second substrate 405b. On the other hand, the electric field in the reflective region 413 is a fringing field  $E_R$ , which has both longitudinal and horizontal components. Consequently, the longitudinal component of  $E_T$  in the transmissive display region 412 is stronger than that of fringing field  $E_R$  in the reflective display region 413. FIG. 6 shows the liquid crystal director distribution in both the transmissive and reflective display regions according to the electric field distribution as shown in FIG. 5. Under each applied voltage state, the liquid crystal director in the transmissive display region 412 is tilted at an angle  $\theta_T$  with respect to the substrate normal direction, and the liquid crystal director in the reflective display region 413 is tilted at an angle  $\theta_R$  with respect to the substrate normal direction. Since the longitudinal component of  $E_T$  in the transmissive display region 412 is stronger than that of  $E_R$  in the reflective display region 413 and the initially vertically aligned negative dielectric anisotropic nematic liquid crystal molecules only respond to the longitudinal component of the electric field, the tilt angle  $\theta_R$  in the reflective display region 413 is smaller than the tilt angle  $\theta_T$  in the transmissive display region 412. As a result, the phase retardation of liquid crystal layer 410 in the transmissive region 412 is larger than that in the reflective region 413. By properly designing the width  $W$  of the reflective display region and the cell gap  $d$ , the phase retardation of liquid crystal layer 410 in the transmissive display region 412 can be made approximately twice that in the reflective display region 413. Because the ambient incident beam passes through the reflective display region 413 twice while the beam from the backlight source passes through the transmissive display region 412 only once, these two beams experience approximately the same overall phase retardation. As a result, the grayscales of both transmissive display mode and reflective display mode approximately overlap each other.

[0053] In order that the transmissive display region 412 is governed by longitudinal electric field while the reflective display region 413 is governed by a fringing field, the ITO common electrode pattern on the first substrate 405a should be approximately mutually complementary to the reflector pattern on the second substrate 405b. FIG. 7A shows the top view of a first example of the mutually complementary common electrode pattern 406a and reflector pattern 407. On the first substrate 405a, one portion of the pixel area is occupied by the ITO electrode pattern 406a, while the other portion of the pixel area is left as an empty area 701 and without ITO electrode coverage. On the second substrate 405b, the whole pixel is covered by a non-patterned ITO pixel electrode 406b, which is further covered by a patterned reflector 407. The area of the reflector pattern 407 on the second substrate 405b approximately matches with the empty area 701 on the first substrate 405a. Therefore, the ITO pattern 406a on the first substrate 405a is approximately mutually complementary with the reflector pattern 407 on the second substrate 405b. To get a better understanding of the mutually complementary relationship, FIG. 7B shows the oblique view of the first example of the mutually complementary common electrode pattern 406a on the first substrate 405a and reflector pattern 407 on the second substrate 405b. In fact, it is not necessary for the reflector pattern 407 on the second substrate 405b to exactly match with the empty area 701 on the first substrate 405a. Mismatches, overlaps or even gaps can exist between the reflector pattern 407 on the second substrate 405b and the ITO pattern 406a on the first substrate 405a.

[0054] Besides the comb-shaped ITO electrode 406a and its complementary strip-shaped reflector pattern 407 shown in FIGS. 7A and 7B, the mutually complementary common electrode 406a and reflector pattern 407 can have other pattern designs. For example, FIG. 7C shows an oblique view of a second example of the mutually complementary common electrode pattern 406a and reflector pattern 407, where the common electrode pattern 406a is cross-shaped and its complementary reflector pattern 407 is rectangle-shaped. FIG. 7D shows the oblique view of a third example of the mutually complementary common electrode pattern 406a and reflector pattern 407, where the common electrode pattern 406a has many circular holes and its corresponding complementary circular-shaped reflector pattern 407. In fact, as long as the common electrode pattern 406a and the reflector pattern 407 are approximately mutually complementary with each other, any other mutually complementary common electrode pattern 406a and reflector pattern 407 designs may be substituted in the present invention.

[0055] Based on the design principle described above, the voltage dependent transmittance and reflectance are calculated in a simulation program. In the simulation, the panel structure design of FIG. 4 and the electrode design of FIG. 7B are employed. Table 1 is a list of the parameters of the liquid crystal mixture, MLC-6680 in this example, used for the simulation. The liquid crystal pretilt angles on both the first alignment film 409a and the second alignment film 409b are 2° with respect to the substrate normal and the cell gap d is 5 μm in both the transmissive display region 412 and the reflective display region 413. The optical axes of the first half-wave film 402a and the first quarter-wave film 403a make 15° and 75° with the transmission axis of the first polarizer 401a, respectively. The transmission axis of the second polarizer 401b is perpendicular to that of the first

polarizer 401a. The optical axis of the second half-wave film 402b is perpendicular to that of the first half-wave film 402a and the optical axis of the second quarter-wave film 403b is perpendicular to that of the first quarter-wave film 403a. The reflector pattern 407 is made of aluminum with reflective index  $n=0.895+i6.67$ .

[0056] FIGS. 8A and 8B are graphs of the voltage dependent reflectance and transmittance curves, respectively, corresponding to the schematic structure shown in FIG. 4 with different reflector width W. In both reflective and transmissive display modes, the ambient incident angle and the detect angle are 0°. From FIG. 8A, it is clear that, in reflective display mode, when the reflector width W changes from 5 μm to 19 μm, the maximum reflectance drops continuously and the on-state voltage increases gradually. Conversely, in the transmissive display mode, FIG. 8B shows that the maximum transmittance and on-state voltage are approximately constant. This is because the longitudinal electric field  $E_T$  in the transmissive display region 412 is almost unaffected by the reflector width W; however, the fringing field  $E_R$  in the reflective display region 413 is mainly affected by the reflector width W. To design a high image quality transmissive LCD, the grayscales of both reflective and transmissive display modes are highly preferable to overlap with each other. The graph in FIG. 8C shows the voltage dependent transmittance and reflectance curves for the first embodiment of the present invention with cell gap  $d=5$  μm and the reflector width  $W=11$  μm. As shown in FIG. 8C, the grayscales of both reflective and transmissive display modes approximately overlap. In addition, both modes have approximately the same threshold voltage and on-state voltage. These characteristics make a transmissive LCD easy to drive, and more importantly, easy to view.

TABLE 1

The parameters of MLC-6608 liquid crystal mixture	
$K_{11}$	$16.7 \times 10^{-12}$ N
$K_{22}$	$7.0 \times 10^{-12}$ N
$K_{33}$	$18.1 \times 10^{-12}$ N
$\epsilon_{//}$	3.6
$\epsilon_{\perp}$	7.8
$n_e$	1.5606 (at $\lambda = 550$ nm)
$n_o$	1.4770 (at $\lambda = 550$ nm)

[0057] The rubbing directions of both the first alignment film 409a and the second alignment film 409b play important roles on image brightness and dynamic response speed. Given the strip electrode design of FIG. 7B as an example, if the rubbing direction is along x-axis direction, which is perpendicular to the strip direction of the reflector pattern 407, then the rise period response speed of both reflective display mode and transmissive display mode is slow. FIG. 9A shows a section view of the equilibrium state director distribution with the strip electrode design of FIG. 7B when rubbing direction is along x-axis direction. Since the fringing field  $E_R$  in the reflective display region 413 is weaker than the longitudinal electric field  $E_T$  in the transmissive display region 412, the liquid crystal molecules in the transmissive display region 412 tilt along x-axis direction first and those in the reflective display region 413 are pushed and pressed. Contrarily, the reoriented liquid molecules in the reflective display region 413 push and press the liquid crystal molecules in the transmissive display region 412. As

a result of the interaction, the liquid crystal molecules on the border of the reflective display region **413** and the transmissive display region **412** deviate out of the x-z plane. In other words, twist deformation evolution occurs on the border of the reflective display region **413** and the transmissive display region **412**. This twist deformation evolution of liquid crystal molecules consumes a long time; therefore, its rise period dynamic speed is slow. On the other hand, if the rubbing direction is along y-axis direction, which is parallel to the strip direction of the reflector pattern **407** as shown in FIG. 7B, then the rise period response speed of both reflective display mode and transmissive mode is relatively fast. FIG. 9B shows the section view of the equilibrium state director distribution with the strip electrode design of FIG. 7B when the rubbing direction is along y-axis. In this example, since the rubbing direction is parallel to the strip direction of the reflector pattern **407**, the liquid crystal molecules in both the transmissive display region **412** and the reflective display region **413** reorient in the y-z plane and no twist deformation occurs in the whole pixel area. Therefore, when rubbing direction is along the strip direction of the reflector pattern **407**, the dynamic rise time is much faster. For comparison purposes, FIG. 9C shows the dynamic response rise period for different rubbing directions. As shown in FIG. 9C, when the rubbing direction is along y-axis, which is parallel to the strip direction of the reflector pattern **407**, the response speed is faster and the brightness is higher. Therefore, for the strip shape reflector pattern, the rubbing angle is preferably parallel to the strip direction of the reflector pattern.

#### Second Embodiment

[0058] In the first embodiment, the common electrode pattern on the first substrate is mutually complementary with the reflector pattern on the second substrate; therefore, the first substrate aligns with the second substrate. To avoid that alignment requirement, FIG. 10 shows the schematic structure according to the second embodiment of the transmissive LCD **000** with uniform cell gap configuration according to the present invention. The structure in the second embodiment includes a first transparent substrate **905a** coated with a non-patterned ITO layer **906a** and a first vertical alignment film **909a**, a second transparent substrate **905b** coated with a patterned ITO layer **906b**, a patterned reflector **907**, a non-conductive planar layer **908**, and a second vertical alignment film **909b**, a vertically aligned negative dielectric anisotropic nematic liquid crystal layer **910** with thickness  $d$  sandwiched between the first vertical alignment film **909a** and the second vertical alignment film **909b**. A negative birefringence c-film **904**, a first quarter-wave retardation film **903a**, a first half-wave retardation film **902a**, and a first polarizer **901a** are further successively laminated outside of the first substrate **905a**, wherein the negative birefringence c-film **904** contacts with the first substrate **905a** and the first polarizer **901a** faces the observer. A second quarter-wave retardation film **903b**, a second half-wave retardation film **902b**, and a second polarizer **901b** are further successively laminated outside of the second substrate **905b**. In addition, a backlight source **911** is further provided outside of the second polarizer **901b**.

[0059] The patterned reflector **907** in the second embodiment may be a high reflectivity conductive metal material, such as aluminum, aluminum alloy, silver and so on. In addition, the patterned reflector **907** may be a nonconductive material, such as a high reflectivity multilayer dielectric thin film. When the patterned reflector **907** is a conductive metal material, then the patterned transparent electrode **906b** and patterned reflector **907** are not connected. Therefore, only the patterned transparent electrode **906b** functions as the pixel electrode. On the other hand, if the patterned reflector **907** is a nonconductive material, then the patterned transparent electrode **906b** and the patterned reflector **907** may be connected however, only the patterned transparent electrode **906b** functions as the pixel electrode. In the second embodiment of the present invention, the transparent electrode pattern **906b** is approximately mutually complementary with the reflector pattern **907**. The hollow arrows in FIG. 10 represent the propagation directions of both the ambient light and the backlight source. As shown in FIG. 10, the patterned ITO layer **906b** is further connected with the drain electrode of the thin-film transistor (TFT), which is not shown here. In fact, FIG. 10 only shows the basic structure of a single pixel area of the transmissive LCD. Other elements such as the thin-film transistor (TFT), color filter, storage capacitor, data line and gate line, although necessary to drive the display device, are not shown. The area of the patterned ITO layer **906b** is defined as the transmissive display region **912**, while the area of the patterned reflector **907** is defined as the reflective display region **913**. More importantly, the patterned ITO layer **906b**, which serves as the pixel electrode, is approximately mutually complementary with the patterned reflector **907**. Therefore, the electric field in the transmissive display region **912** is different from that in the reflective display region **913**.

[0060] FIG. 11 shows the electric field distribution in the transmissive display region **912** and the reflective display region **913** of one pixel area according to the second embodiment. Since the bottom patterned ITO layer **906b** only approximately covers the transmissive display region **912** and does not cover the reflective display region **913**, the electric field in the transmissive display region **912** is a uniform longitudinal field  $E_T$ , which is perpendicular to the first substrate **905a** and the second substrate **905b**. On the other hand, the electric field in the reflective region **913** is a fringing field  $E_R$ , which has both longitudinal and horizontal components. Consequently, the longitudinal component of  $E_T$  in the transmissive display region **912** is stronger than that of  $E_R$  in the reflective display region **913**. The schematic diagram in FIG. 12 shows the liquid crystal director distribution in both transmissive and reflective display regions corresponding to the electric field distribution as shown in FIG. 11.

[0061] Under each applied voltage state, the liquid crystal director in the transmissive display region **912** is tilted at a  $\theta_T$  angle with respect to the substrate normal direction, and the liquid crystal director in the reflective display region **913** is tilted at a  $\theta_R$  angle with respect to the substrate normal direction. Since the longitudinal component of  $E_T$  in the transmissive display region **912** is stronger than that of  $E_R$  in the reflective display region **913** and the initially vertically aligned negative dielectric anisotropic nematic liquid crystal molecules only respond to the longitudinal component of the electric field, the tilt angle  $\theta_R$  in the reflective display region **913** is smaller than the tilt angle  $\theta_T$  in the

transmissive display region 912. As a result, the phase retardation of liquid crystal layer 910 in the transmissive region 912 is larger than that in the reflective region 913. By properly designing the width  $W$  of the reflective display region and the cell gap  $d$ , the phase retardation of liquid crystal layer 910 in the transmissive display region 912 can be made approximately twice the phase retardation of liquid crystal layer 910 in the reflective display region 913. Because the ambient incident beam passes through the reflective display region 913 twice while the beam from the backlight source passes through the transmissive display region 912 only once, these two beams experience approximately the same phase retardation. As a result, the grayscales of both transmissive display mode and reflective display mode approximately overlap.

[0062] The patterned ITO electrode 906b on the second substrate 905b should be approximately mutually complementary to the reflector pattern 907 on the second substrate 905b so that the transmissive display region 912 is governed by longitudinal electric field while the reflective display region 913 is governed by a fringing field. FIG. 13A shows the top view of a first example of the mutually complementary ITO electrode pattern 906b and reflector pattern 907. On the first substrate 905a, the ITO electrode 906a is non-patterned. On the second substrate 905b, one portion is covered by a patterned ITO pixel electrode 906b, while the other portion is covered by a complementarily patterned reflector 907. The ITO pattern 906b is approximately mutually complementary with the reflector pattern 907 on the second substrate 905b. FIG. 13B shows the oblique view of the first example of the mutually complementary ITO electrode pattern 906b and reflector pattern 907 on the second substrate 905b. In fact, the reflector pattern 907 does not need to be exactly complementary with the ITO pattern 906b on the second substrate 905b. Mismatches and gaps may exist between the reflector pattern 907 and the ITO pattern 906b on the second substrate 905b.

[0063] Besides the comb-shaped ITO electrode 906b and its complementary strip-shaped reflector pattern 907 shown in FIGS. 13A and 13B, the mutually complementary ITO electrode 906b and reflector pattern 907 may have alternative pattern designs. For example, FIG. 13C shows the oblique view of a second example of mutually complementary ITO electrode pattern 906b and reflector pattern 907, where the ITO electrode pattern 906b is cross-shaped and its complementary reflector pattern 907 is rectangle-shaped. FIG. 13D shows the oblique view of a third example of the mutually complementary ITO electrode pattern 906b and reflector pattern 907, where the ITO electrode pattern 906b has circular holes and its corresponding complementary reflector pattern 907 is circle-shaped. In fact, as long as the ITO electrode pattern 906b and the reflector pattern 907 are approximately mutually complementary with each other, any other mutually complementary ITO electrode pattern 906b and reflector pattern 907 designs may be substituted in the present invention.

[0064] Based on the design principle described above, the voltage dependent transmittance and reflectance were calculated with a simulation program. In the simulation, the panel structure design of FIG. 10 and the electrode design of FIG. 13B were employed. The liquid crystal mixture MLC-6608 was used and the parameters of the liquid crystal mixture are listed in Table 1. The liquid crystal pretilt angles

on both the first alignment film 909a and the second alignment film 909b were  $2^\circ$  with respect to the substrate normal and the cell gap  $d$  was  $5 \mu\text{m}$  in both transmissive display region 912 and reflective display region 913. The optical axes of the first half-wave film 902a and the first quarter-wave film 903a make  $15^\circ$  and  $75^\circ$  with the transmission axis of the first polarizer 901a, respectively. The transmission axis of the second polarizer 901b is perpendicular to that of the first polarizer 901a. The optical axis of the second half-wave film 902b is perpendicular to that of the first half-wave film 902a and the optical axis of the second quarter-wave film 903b is perpendicular to that of the first quarter-wave film 903a. The reflector pattern 907 is made of aluminum with reflective index  $n=0.895+i-6.67$ .

[0065] FIGS. 14A and 14B demonstrate the voltage dependent reflectance curves and the voltage dependent transmittance curves, respectively, of the second embodiment of FIG. 10 according to the present invention with different reflector widths  $W$ . In both reflective and transmissive display modes, the ambient incident angle and the detect angle are  $0^\circ$ . From FIG. 14A, it is clear that, in the reflective display mode, when the reflector width  $W$  changes from  $5 \mu\text{m}$  to  $19 \mu\text{m}$ , the maximum reflectance drops continuously and the on-state voltage increases gradually. In contrast, in the transmissive display mode, FIG. 14B shows that the maximum transmittance and on-state voltage is approximately constant because the longitudinal electric field  $E_T$  in the transmissive display region 912 is negligibly affected by the reflector width  $W$ . Unlike the transmissive display region 912, the fringing field  $E_R$  in the reflective display region 913 is affected by the reflector width  $W$ . Therefore, to produce a high image quality transfective LCD, the grayscales of both reflective and transmissive display modes preferably overlap. FIG. 14C shows the voltage dependent transmittance and reflectance curves of the second embodiment of this invention with cell gap  $d=5 \mu\text{m}$  and the reflector width  $W=11 \mu\text{m}$ . From this figure, the grayscales of both reflective and transmissive display modes overlap. In addition, both modes have approximately the same threshold voltage and on-state voltage. These characteristics make the transfective LCD of the present invention easy to drive, and more importantly, easy to view.

[0066] The rubbing directions of both the first alignment film 909a and the second alignment film 909b affect the image brightness and dynamic response speed. Given the strip electrode design of FIG. 13B as an example, if the rubbing direction is along x-axis direction, which is perpendicular to the strip direction of the reflector pattern 907, then the rise period response speed of both the reflective display mode and the transmissive display mode are slow. FIG. 15A shows the section view of the equilibrium state director distribution with the strip electrode design of FIG. 13B when rubbing direction is along x-axis direction. Since the fringing field  $E_R$  in the reflective display region 913 is weaker than the longitudinal electric field  $E_T$  in the transmissive display region 912, the liquid crystal molecules in the transmissive display region 912 will tilt along the x-axis direction first and those in the reflective display region 913 are pushed and pressed. Contrarily, the reoriented liquid molecules in the reflective display region 913 push and press the liquid molecules in the transmissive display region 912. As a result of the interaction, the liquid crystal molecules on the border of the reflective display region 913 and the transmissive display region 912 deviate out of the x-z plane.

In other words, a twist deformation evolution occurs on the border of the reflective display-region **913** and the transmissive display region **912**. This twist deformation evolution of the liquid crystal molecules occurs over a long time period; therefore, the rise period dynamic speed is slow. On the other hand, if the rubbing direction is along y-axis direction, which is parallel to the strip direction of the reflector pattern **907** as shown in FIG. **13B**, then the rise period response speed of both reflective display mode and transmissive mode is relatively fast. FIG. **15B** shows the section view of the equilibrium state director distribution with the strip electrode design of FIG. **13B** when rubbing direction is along y-axis direction. In this case, since the rubbing direction is parallel to the strip direction of the reflector pattern **907**, the liquid crystal molecules in both transmissive display region **912** and reflective display region **913** reorient in the y-z plane and no twist deformation occurs in the pixel area. Therefore, when the rubbing direction is along the strip direction of the reflector pattern **907**, the dynamic rise time is faster. As a comparison, FIG. **15C** shows the rise period dynamic response for different rubbing direction cases. As shown in FIG. **15C**, when the rubbing direction is along y-axis, which is parallel to the strip direction of the reflector pattern **907**, not only the response speed is faster, but the brightness is increased. Therefore, for the strip shape reflector pattern, the rubbing angle is preferably parallel to the strip direction of the reflector pattern.

[**0067**] In summary, the apparatus, method, system and device of the present invention provides a new transmissive LCD design with uniform cell gap configuration throughout the transmissive and reflective display regions. Use of a mutually complementary common electrode pattern and reflector pattern or mutually complementary ITO pixel electrode pattern and reflector pattern, produces an electric field in the transmissive display region that is a uniform longitudinal field while the electric field in the reflective display region is a fringing field. Therefore, the initially vertically aligned negative dielectric anisotropic nematic liquid crystal material forms a smaller tilt angle with respect to the substrate normal in the reflective display region and simultaneously a larger tilt angle with respect to the substrate normal in the transmissive display region. Consequently, the ambient incident light experiences a reduced phase retardation in the reflective display region while the light from the backlight source experiences an increased phase retardation. Since the ambient light passes through the reflective display region twice while the light from the backlight source only passes through the transmissive display region once, by properly designing the electrodes and the reflector width, the light from both ambient light source and backlight source experience approximately the same phase retardation in both reflective and transmissive display regions. As a result, the electro-optical performance curves of both transmissive display mode and reflective display mode overlap.

[**0068**] While the invention has been described, disclosed, illustrated and shown in various terms of certain embodiments or modifications which it has presumed in practice, the scope of the invention is not intended to be, nor should it be deemed to be, limited thereby and such other modifications or embodiments as may be suggested by the teachings herein are particularly reserved especially as they fall within the breadth and scope of the claims here appended.

**1-16.** (canceled)

**17.** A transmissive liquid crystal display comprising:

a first substrate having at least a first vertical alignment film and a transparent common electrode layer, wherein said transparent common electrode layer is laminated between said vertical alignment film and said first substrate;

a second substrate having at least a second vertical alignment film, a non-conductive layer, a patterned transparent electrode, and a patterned reflector, wherein said patterned transparent electrode, said patterned reflector, and said non-conductive layer are sandwiched between said second vertical alignment film and said second substrate, wherein said patterned reflector has a reflector pattern that is an approximately mutually complementary pattern to said patterned transparent electrode to form alternating transmissive display regions and reflective display regions on said second substrate, wherein a substantially longitudinal electric field is generated in said transmissive display regions and a substantially fringing field is generated in said reflective display regions; and

a liquid crystal material with negative dielectric anisotropy sandwiched between said first vertical alignment film and said second vertical alignment film.

**18.** The transmissive liquid crystal display of claim 17, wherein said patterned transparent electrode on said second substrate functions as a pixel electrode.

**19.** A method to produce a transmissive liquid crystal display device including the steps of:

providing a first substrate having a first vertical alignment film thereon and a second substrate having a second vertical alignment film thereon;

providing a liquid crystal material with negative dielectric anisotropy between said first vertical alignment film and said second vertical alignment film;

providing a patterned transparent electrode on one of said first substrate and said second substrate;

providing a non-patterned transparent electrode on an opposite one of said first substrate and said second substrate; and

providing a patterned reflector on said second substrate, wherein said patterned transparent electrode pattern and said patterned reflector pattern are approximately mutually complementary to each other.

**20.** The method of claim 19, wherein said patterned transparent electrode is on said first substrate, further comprising:

connecting said patterned reflector on said second substrate to said non-patterned transparent electrode on said second substrate so that at least said non-patterned transparent electrode functions as a pixel electrode.

**21.** The method of claim 19, wherein said patterned transparent electrode is on said second substrate and only said patterned transparent electrode functions as a pixel electrode.

\* \* \* \* \*

专利名称(译)	具有垂直对准的半透半反液晶显示器		
公开(公告)号	<a href="#">US20080043188A1</a>	公开(公告)日	2008-02-21
申请号	US11/975230	申请日	2007-10-18
[标]申请(专利权)人(译)	中佛罗里达大学 统宝光电股份有限公司		
申请(专利权)人(译)	中佛罗里达大学研究基金会注册成立 统宝光电股份有限公司，		
当前申请(专利权)人(译)	佛罗里达中部研究基金会，Inc.的 统宝光电股份有限公司。		
[标]发明人	ZHU XINYU GE ZHIBING WU SHIN TSON		
发明人	ZHU, XINYU GE, ZHIBING WU, SHIN-TSON		
IPC分类号	G02F1/1335 H01J9/20		
CPC分类号	G02F2001/134381 G02F1/133555		
其他公开文献	US7969540		
外部链接	<a href="#">Espacenet</a> <a href="#">USPTO</a>		

摘要(译)

发明了透射和反射显示区域中具有均匀单元间隙配置的半透半反液晶显示器。互补的公共电极图案和反射器图案或互补的ITO像素电极图案和反射器图案在透射显示区域中产生电场，该电场在作为边缘场的反射显示区域中具有均匀的纵向场和电场。在电极之间的初始垂直排列的负介电各向异性向列液晶材料相对于反射显示区域中的基板法线形成较小的倾斜角，而相对于透射显示区域中的基板法线形成较大的倾斜角。因此，环境入射光在反射显示区域中经历较小的相位延迟，而来自背光源的光经历较大的相位延迟。由于环境光两次通过反射显示区域，而来自背光源的光仅通过透射显示区域一次，通过适当设计电极和反射器宽度，来自环境光源和背光源的光将几乎经历反射和透射显示区域中的相位延迟相同。结果，双透射显示模式和反射显示模式的电光性能曲线重叠。

