



(19) **United States**

(12) **Patent Application Publication**
Shiraogawa et al.

(10) **Pub. No.: US 2007/0064168 A1**
(43) **Pub. Date: Mar. 22, 2007**

(54) **OPTICAL ELEMENT, LIGHT
CONDENSATION BACKLIGHT SYSTEM,
AND LIQUID CRYSTAL DISPLAY**

(52) **U.S. Cl. 349/56**

(75) **Inventors: Miki Shiraogawa, Osaka (JP);
Kentarou Takeda, Osaka (JP);
Kazutaka Hara, Osaka (JP); Naoki
Takahashi, Osaka (JP)**

(57) **ABSTRACT**

Correspondence Address:
**WESTERMAN, HATTORI, DANIELS &
ADRIAN, LLP**
1250 CONNECTICUT AVENUE, NW
SUITE 700
WASHINGTON, DC 20036 (US)

An optical element comprising: a polarizing element (A), separating incident light into polarization to then emit light, and made of a cholesteric liquid crystal, wherein the polarizing element (A) has a distortion rate with respect to emitting light to incident light in the normal direction of 0.5 or more and a distortion rate with respect to emitting light to incident light at an angle inclined from the normal direction by 60 degrees or more of 0.2 or less, the polarizing element (A) has a function increasing a linearly polarized light component of emitting light as incidence angle is larger; a 1/2 wavelength plate (B); a retardation layer (C) giving almost zero retardation to incident light in the front direction (normal direction) and giving a retardation to incident light in a direction inclined from the normal direction; and a 1/4 wavelength plate (D); being arranged in this order, and further a linearly polarized light reflection polarizer (E), transmitting linearly polarized light with one polarization axis and selectively reflecting linearly polarized light with the other polarization axis perpendicular to the one polarization axis, is arranged on the 1/4 wavelength plate (D) so that the transmission axis of the linearly polarized light reflection polarizer (E) and an axis of the transmitted light, which is transmitted through the polarizing element (A) to the 1/4 wavelength plate (D) in this order, are the same direction. The optical element is capable of condensation and collimation of incident light from a light source and capable of suppressing transmission of light in an arbitrary direction.

(73) **Assignee: NITTO DENKO CORPORATION,**
Osaka (JP)

(21) **Appl. No.: 10/576,772**

(22) **PCT Filed: Aug. 24, 2004**

(86) **PCT No.: PCT/JP04/12121**

§ 371(c)(1),
(2), (4) **Date: Apr. 21, 2006**

(30) **Foreign Application Priority Data**

Oct. 23, 2003 (JP) 2003-363241

Publication Classification

(51) **Int. Cl.**
G02F 1/1333 (2006.01)

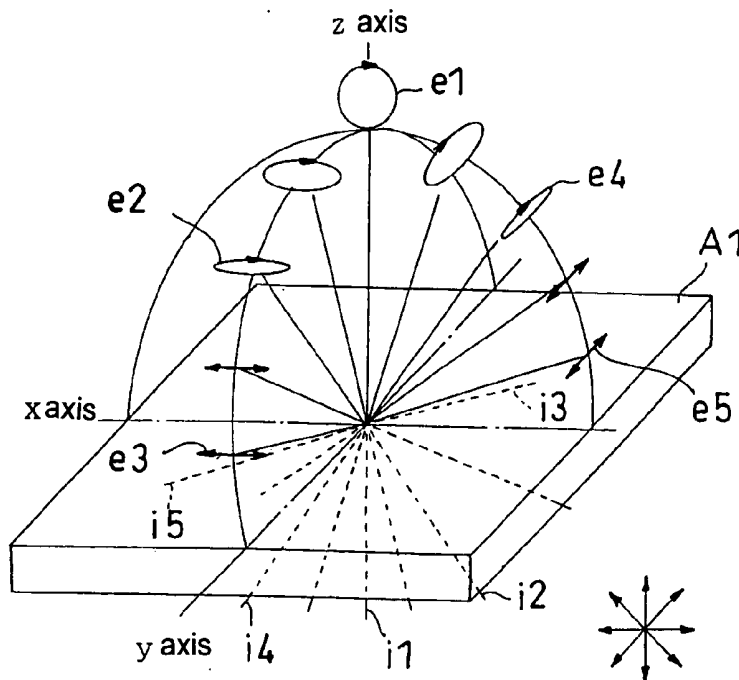

FIG. 1(A)

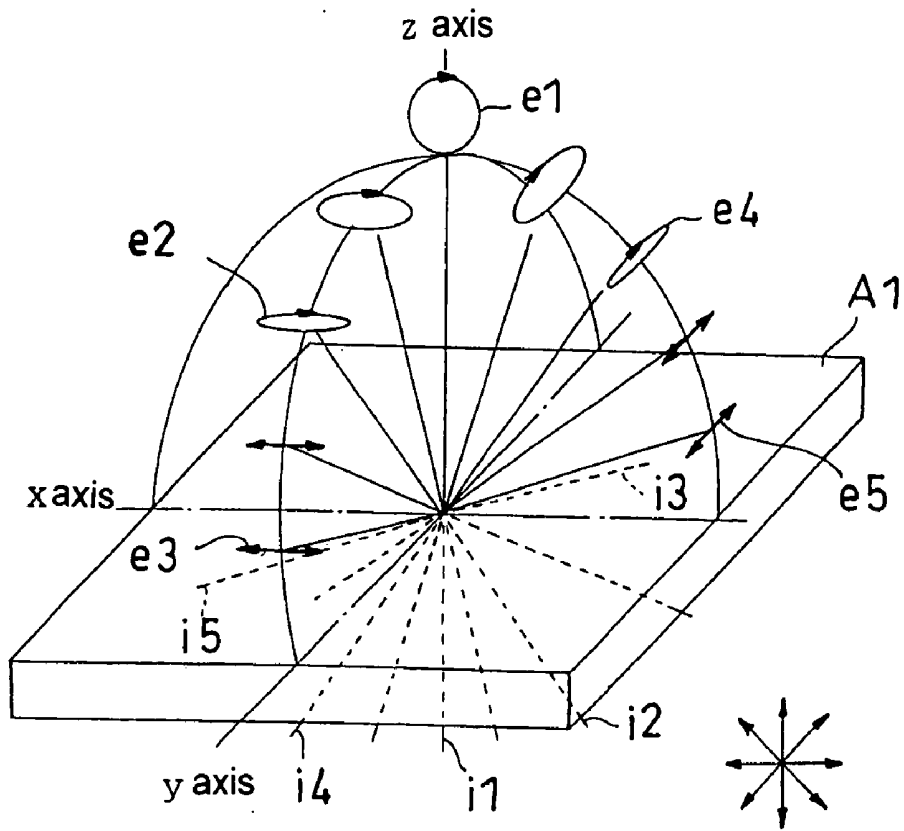

FIG. 1(B)

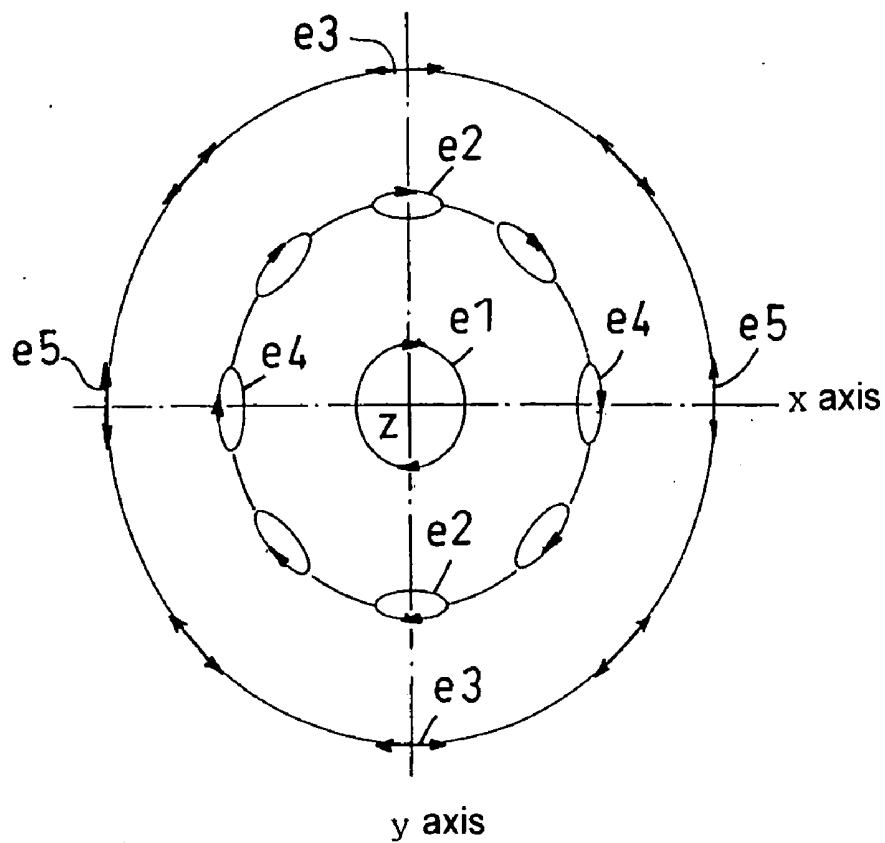

FIG. 2(A)

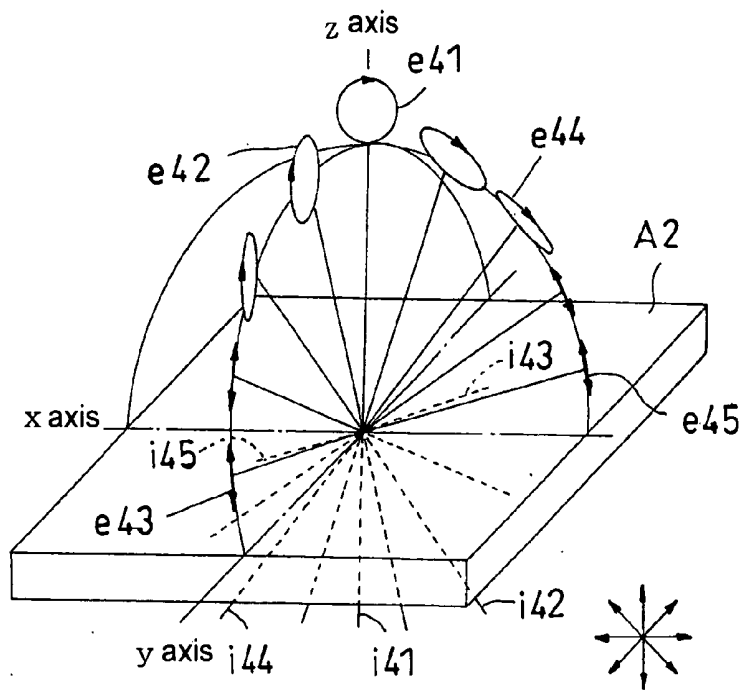

FIG. 2(B)

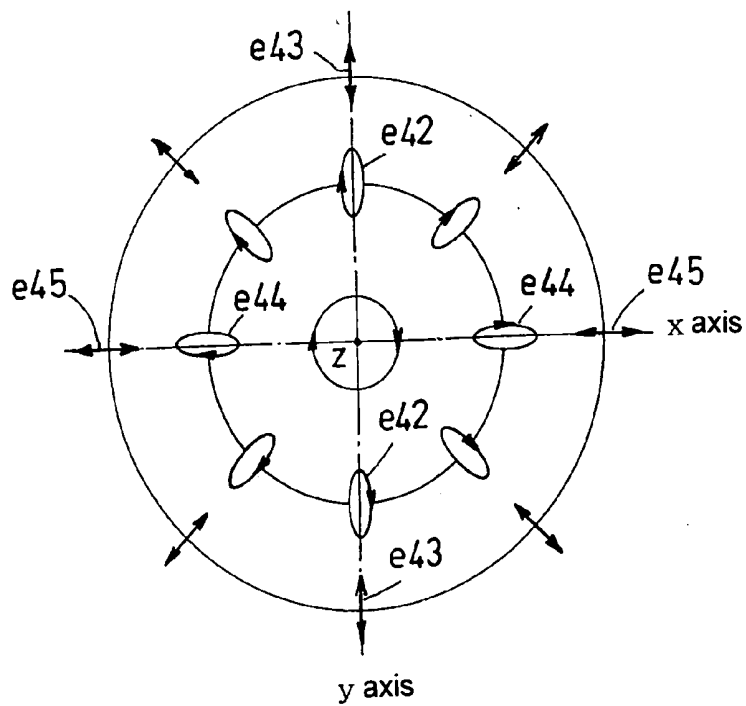

FIG. 3

(i)



(ii)



(iii)



(iv)

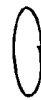

FIG. 4

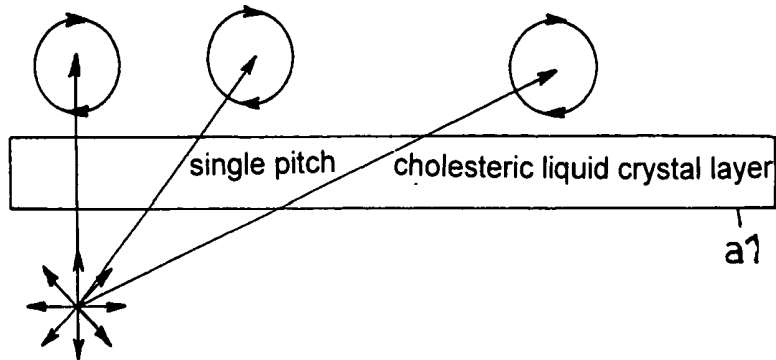

FIG. 5

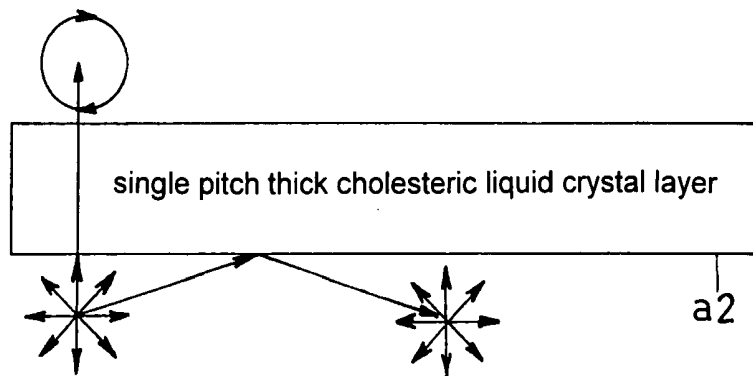

FIG. 6

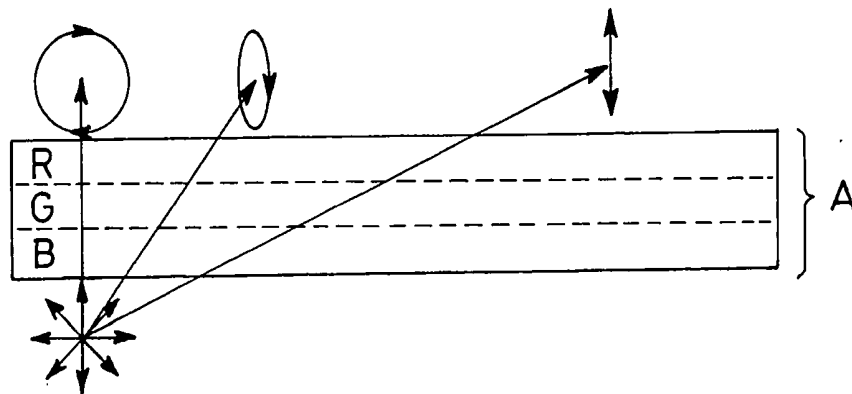

FIG. 7

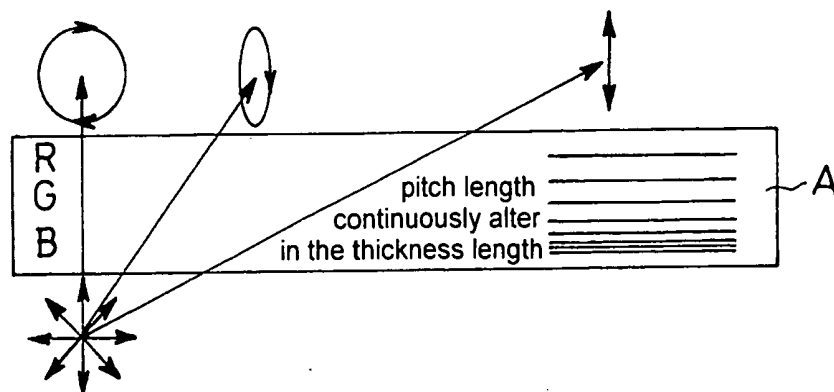

FIG. 8

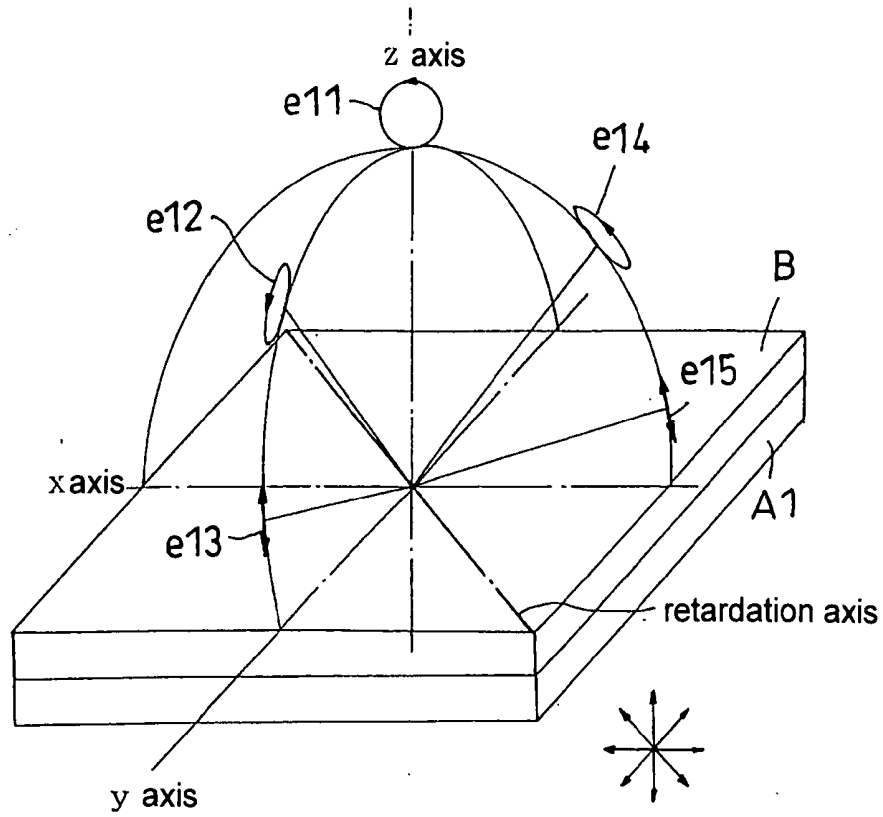

FIG. 9

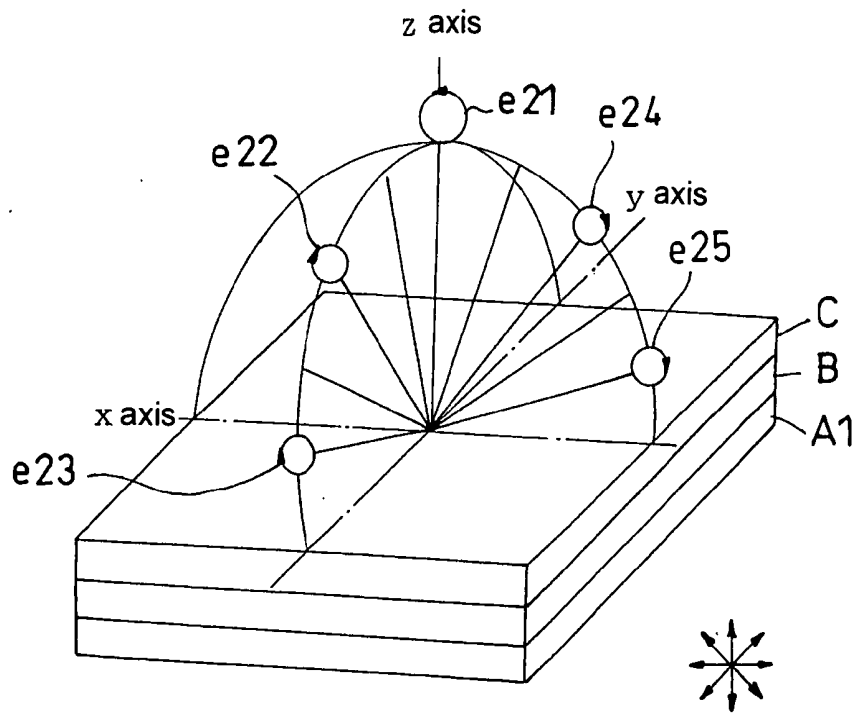

FIG. 10

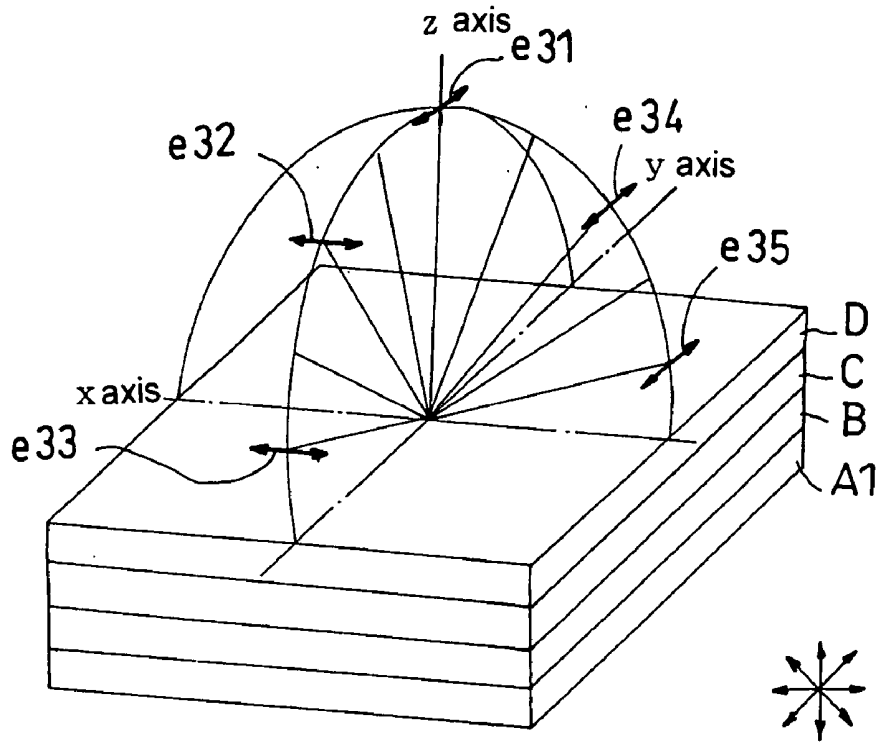

FIG. 11

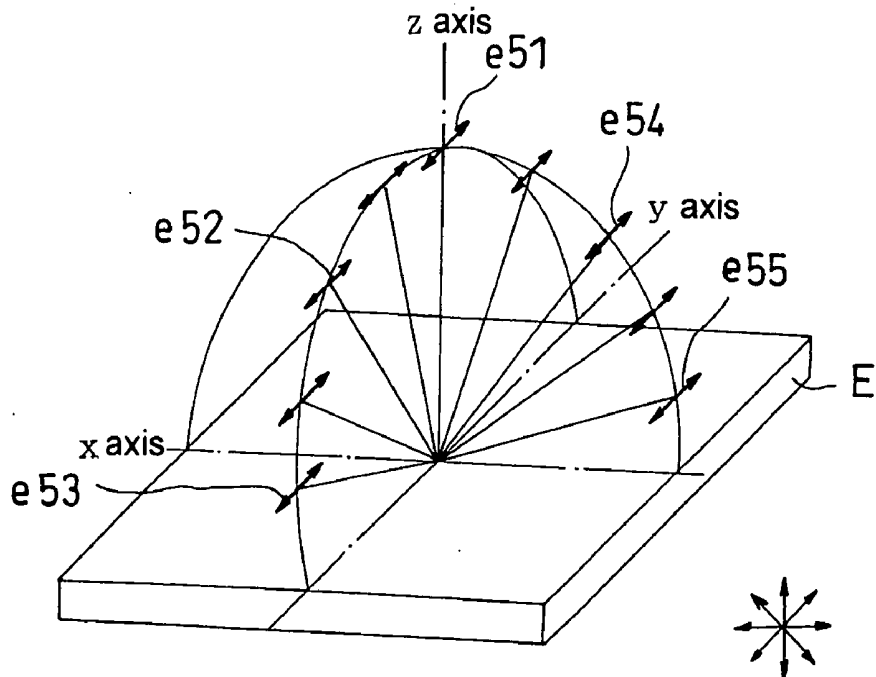

FIG. 12

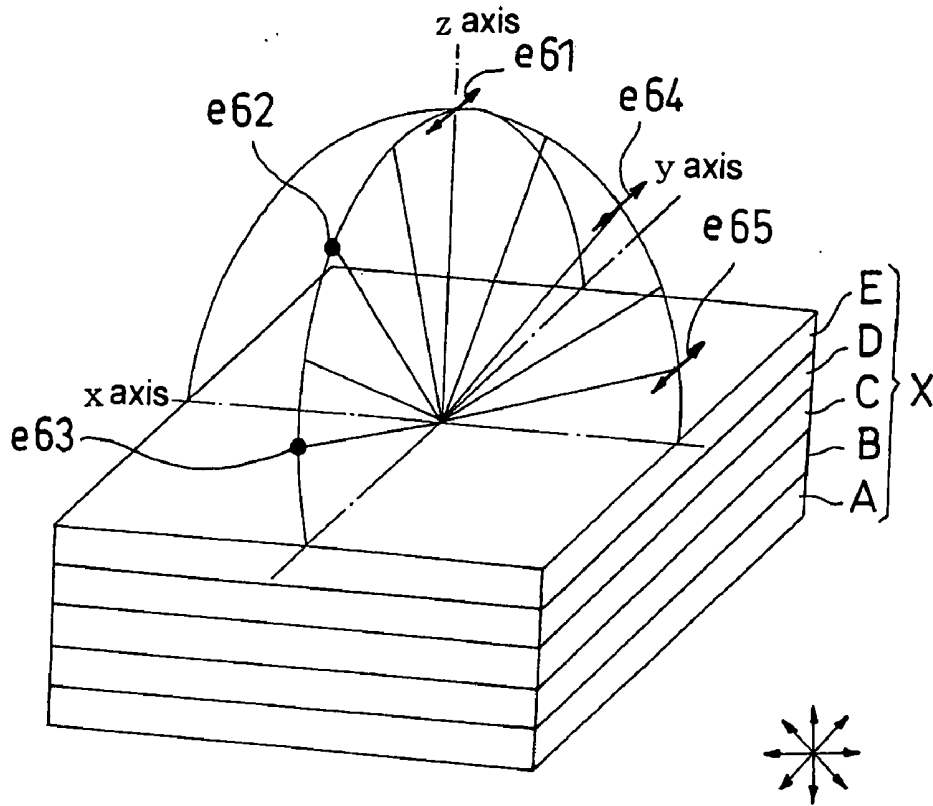

FIG. 13

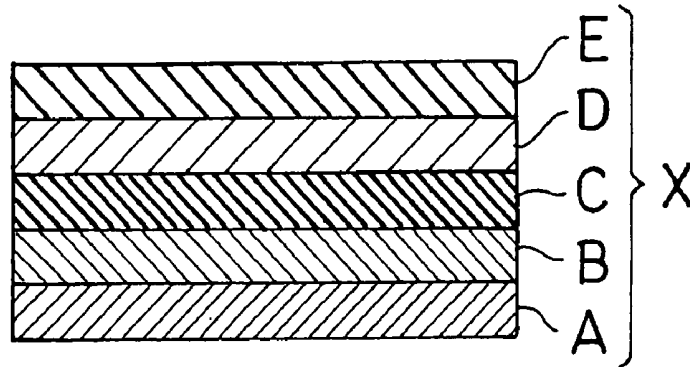

FIG. 14

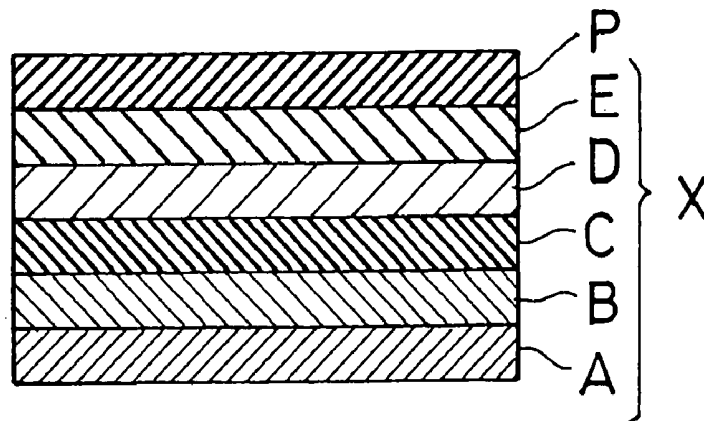

FIG. 15

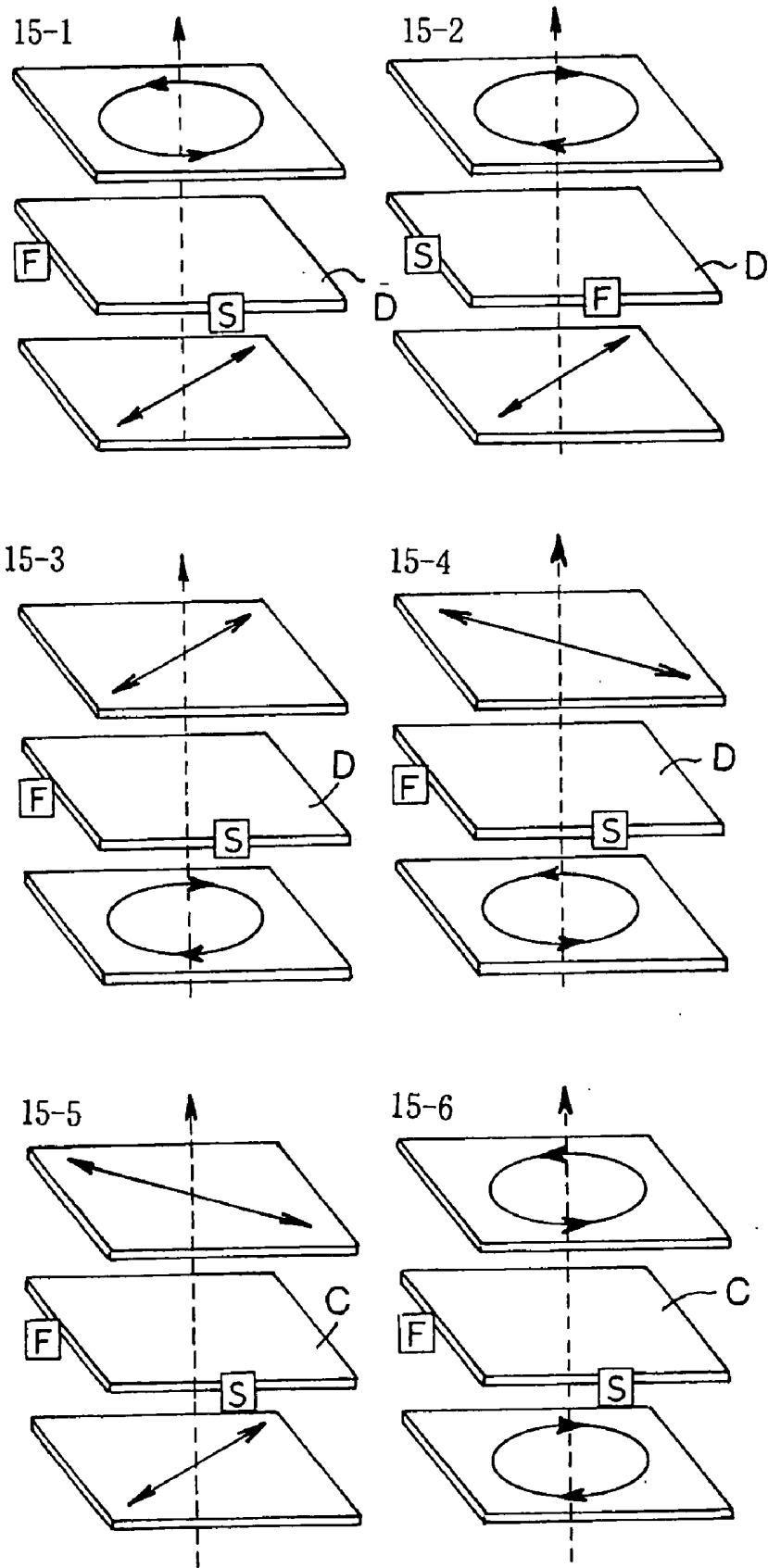

FIG. 16

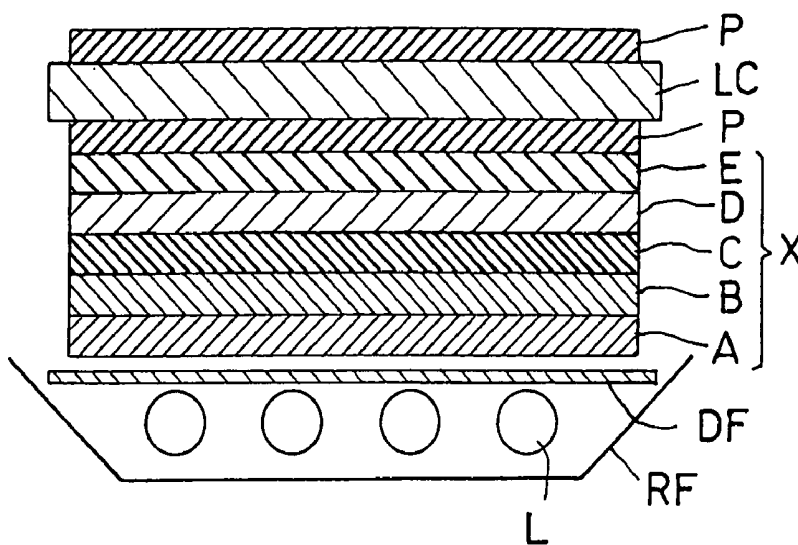

FIG. 17

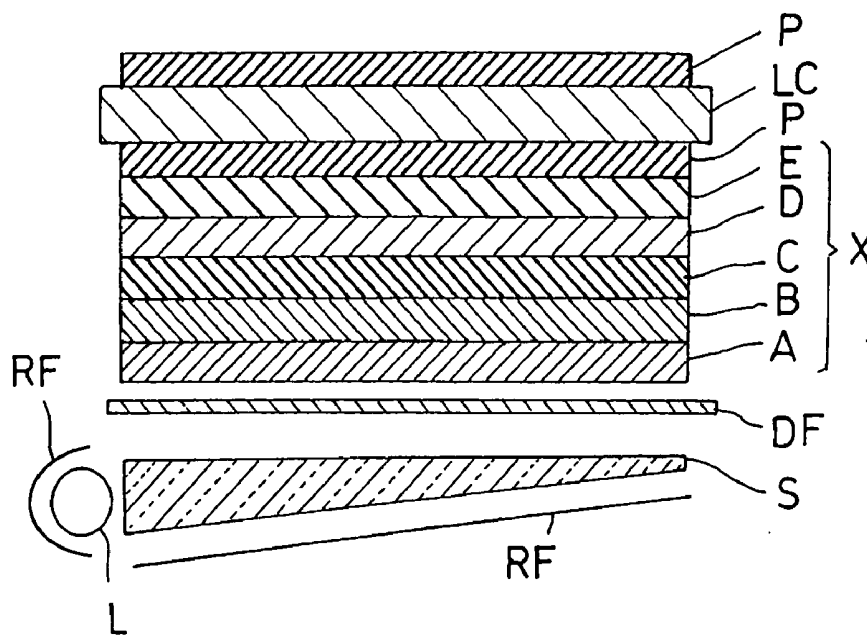

FIG. 18

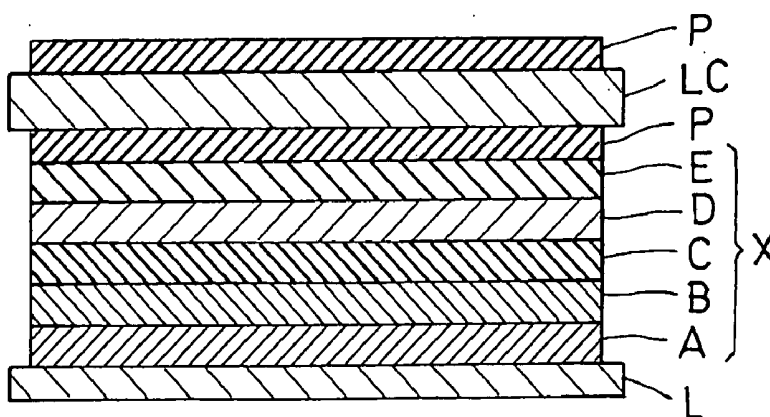

FIG. 19

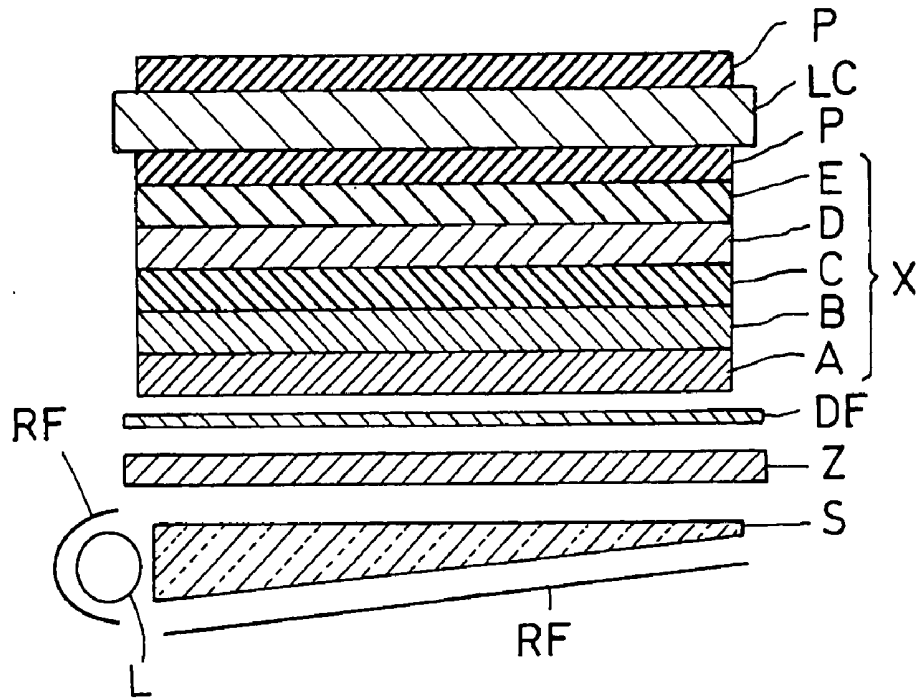

FIG. 20

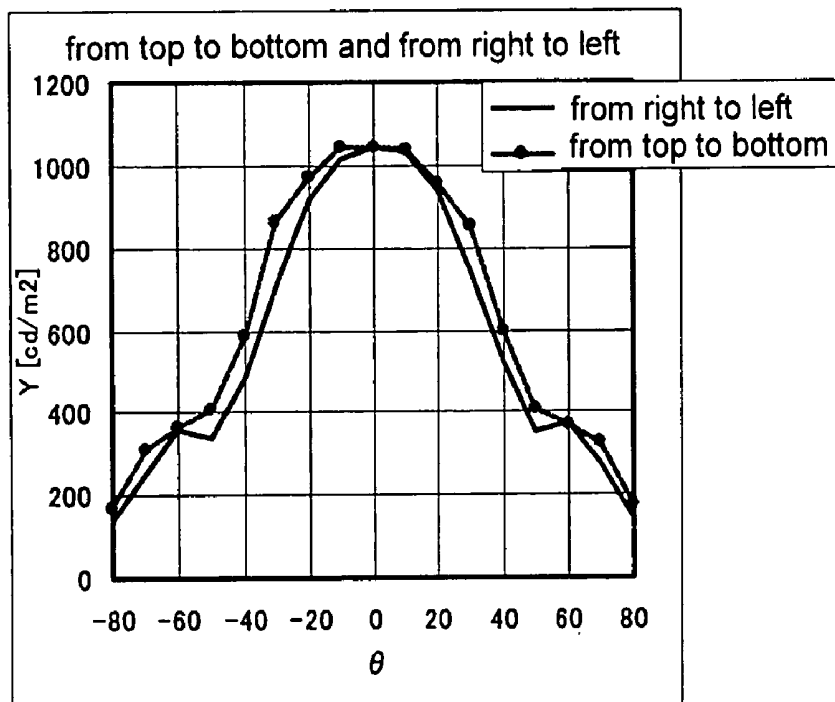

FIG. 21

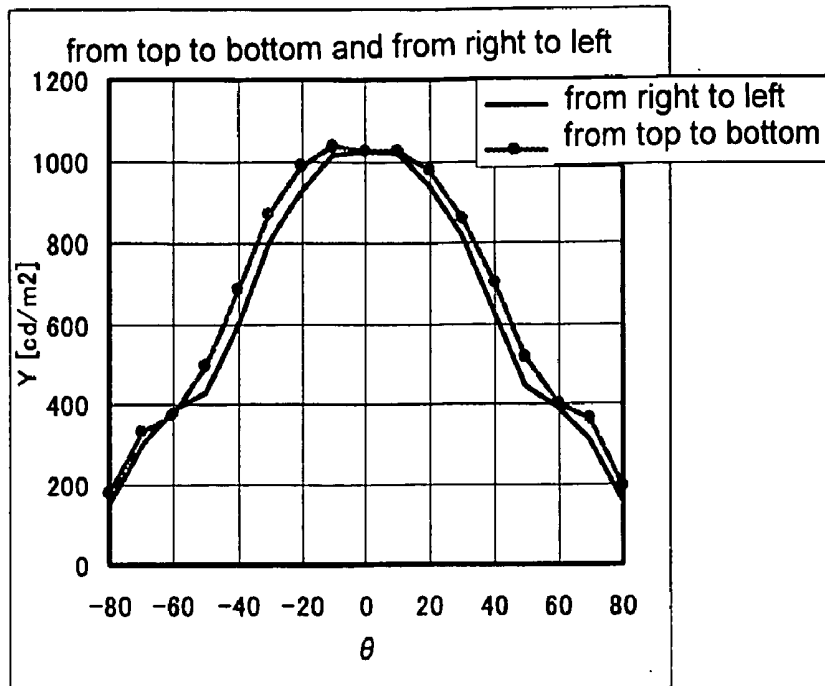

FIG. 22

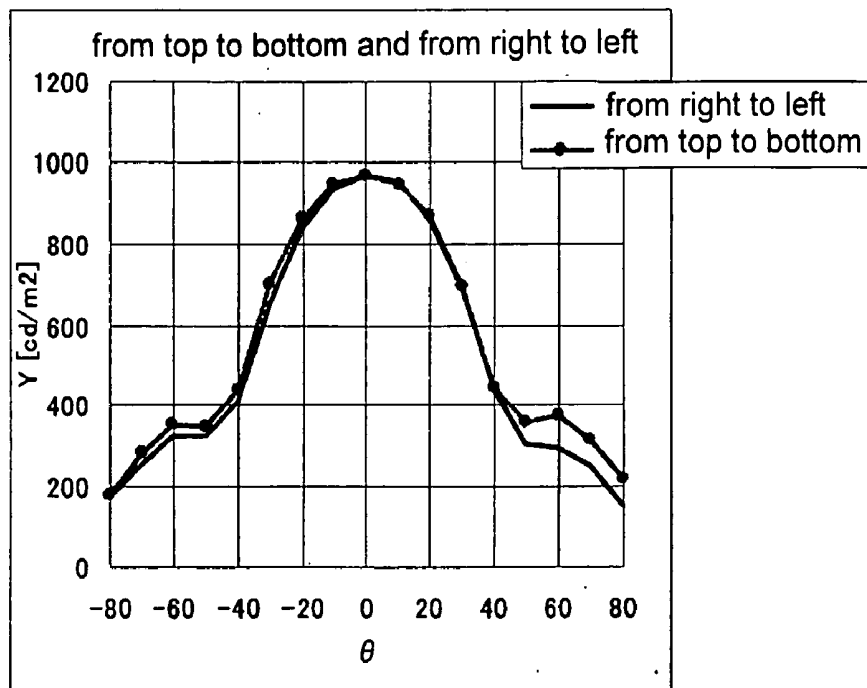

FIG. 23

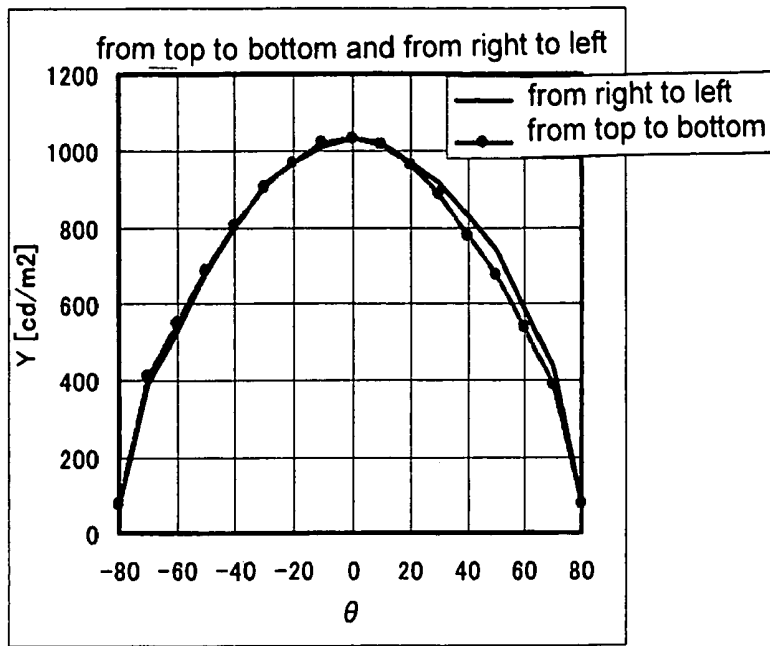

FIG. 24

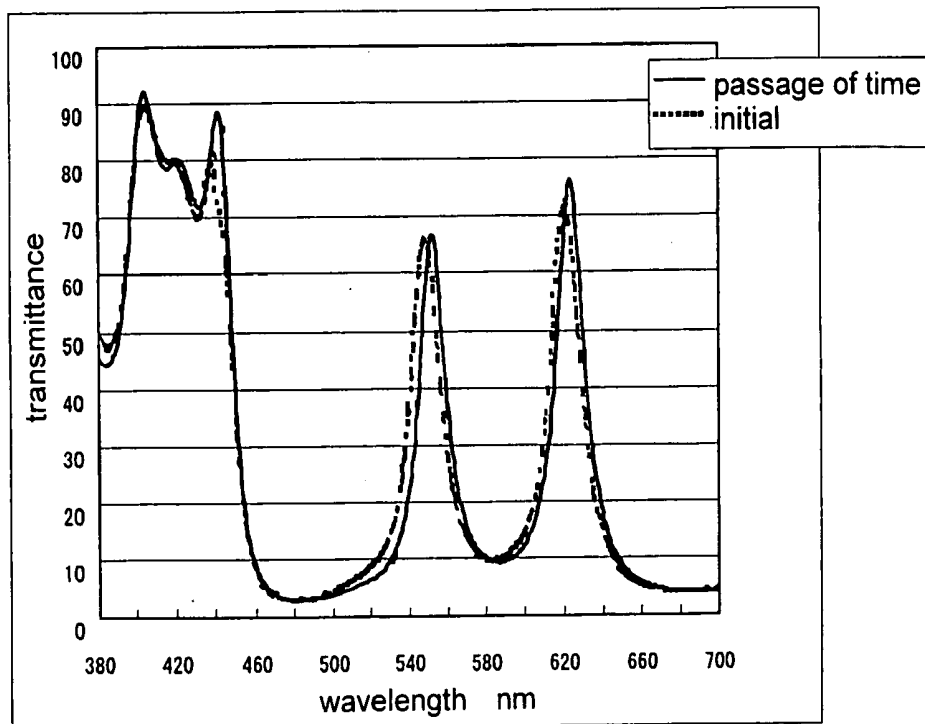

FIG. 25

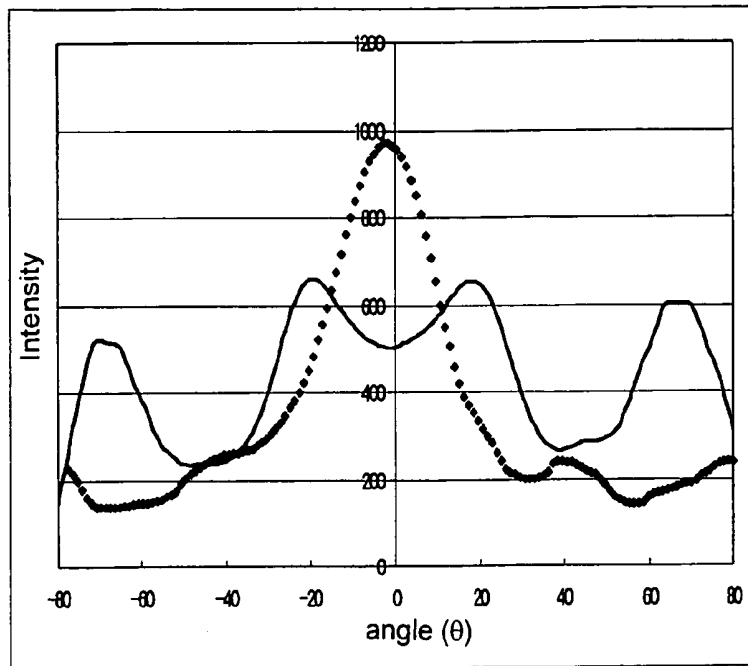

FIG. 26

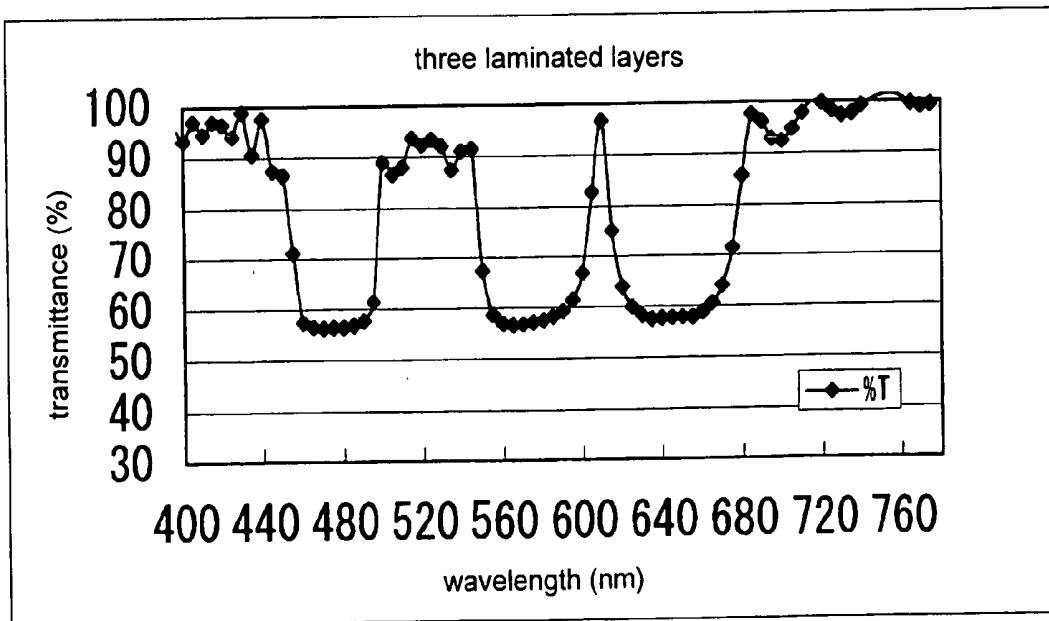
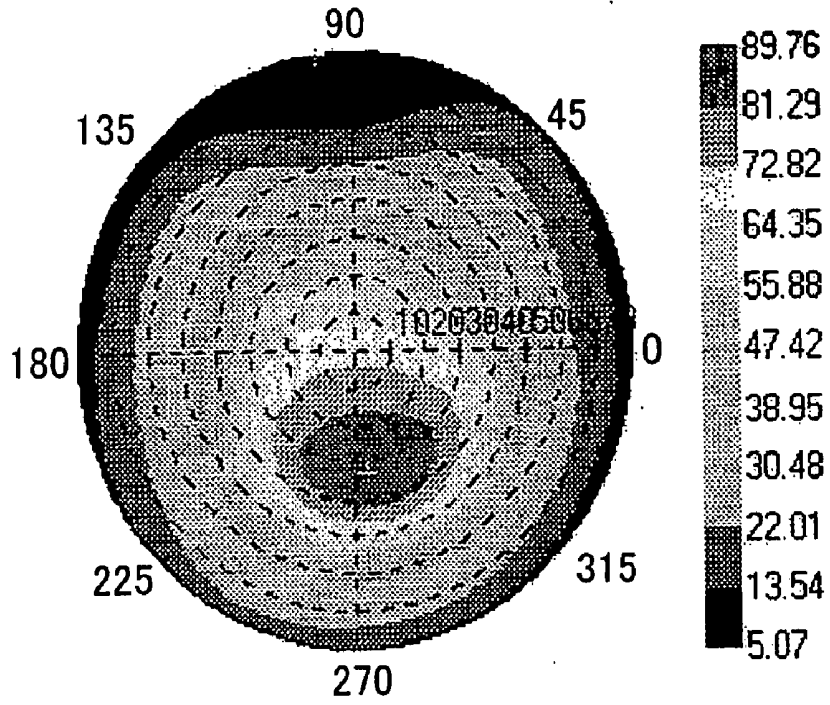

FIG. 27



OPTICAL ELEMENT, LIGHT CONDENSATION BACKLIGHT SYSTEM, AND LIQUID CRYSTAL DISPLAY

TECHNICAL FIELD

[0001] The present invention relates to an optical element using a polarizing element. This invention further relates to a light condensation backlight system using the optical element and still further to a liquid crystal display using the same.

BACKGROUND ART

[0002] There has been conventionally conducted a trial to condense or collimate light from a diffusion light source using an optical film having a flat front surface or to control a transmittance of light therefrom in a specific direction of the optical film having a flat front surface. A typical example of such a trial is a method in which a bright line light source is combined with a band pass filter (see, for example, a publication of JP-A No. 6-235900, a publication of JP-A No. 2-158289, a publication of JP-A No. 10-321025, a specification of U.S. Pat. No. 6,307,604, a specification of DE 3836955 A, a specification of DE 422028 A, a specification of EP 578302 A, a specification of US 2002/34009 A and a pamphlet of WO 02/25687 A1). There has been proposed a method in which a band pass filter is disposed on a CRT, or a display with a light source emitting a bright line such as electroluminescence to thereby condense and collimate light; or the like (see, for example, a specification of US 2001/521643 A, a specification of US 2001/516066 A, a specification of US 2002/036735 A, a publication of JP-A No. 2002-90535 and a publication of JP-A No. 2002-258048).

[0003] A method has been proposed in which polarization and retardation are combined with each other or the like (see a specification of JP No. 2561483). An optical element has been proposed, in other patent literatures, that is constituted of a reflection polarizer-a rotatory polarization plate-a reflection polarizer (see a specification of U.S. Pat. No. 4,984,872, a specification of US 2003/63236 A and a pamphlet of WO 03/27731 A1). An optical element has been proposed that uses a hologram material (see a pamphlet of WO 03/27756 A1).

[0004] In a method in which a bright line spectrum is used as an optical film imparting directivity to a diffusion light source, however, since a requirement is a high precision level related to wavelength matching between a kind of a light source and a band pass filter, which has made fabrication thereof difficult. On the other hand, no large problem occurs in a case where a monochromatic light is used, whereas in a case where adaptation is required for the three primary colors, coloration is felt unless transmittance of the colors changes at the same ratio according an incidence angle. Therefore, in combination of a bright line light source and a band pass filter, a requirement is a precise matching of a wavelength of the light source with a band pass filter, which is high in technical difficulty.

[0005] For example, in the publications of JP-A 2002-90535 and JP-A 2002-258048, used for light condensation in the front direction is a reflecting plate obtained by combining a left circularly polarized light separating plate and a right circularly polarized light separating plate together or

alternatively a reflecting plate obtained by inserting a $\frac{1}{2}$ wavelength plate between circularly polarized light separating plates with the same direction of the rotation. In this system, a necessity arises for forming corresponding layers for respective wavelengths of a light source, which necessitates lamination of three sets for color display. This has led to complexity in construction and a high cost.

[0006] In a case where polarization and retardation are used, there has arisen a tendency that a secondary transmission region emerges at a further larger incidence angle if an emittable angle range is narrowed.

[0007] In a case where obliquely incident light passes through a retardation plate, there is generally a tendency that an optical path length is longer; and with an increase in optical path length, a difference in optical path length also increases. With combination of this characteristic and a polarizer adopted, it is possible to fabricate a polarizing element having angular dependency of transmittance as taught in the specification of JP-2561483. Such a polarizing element can change a transmittance according to an incidence angle. For example, with such a polarizing element, it is possible that a transmittance in the front direction is higher, while a transmittance of an obliquely incident light is lower.

[0008] If a layer imparting no retardation in the front direction and a retardation of $\frac{1}{2}$ wavelength in an oblique direction is inserted between optical elements separating circularly polarized light in the same direction of the rotation, light is totally reflected in an oblique direction; therefore, light is transmitted only in the front direction (see Publication of JP-A No. 10-321025). In this method, however, in a case where a condition that total reflection occurs at a specific angle is set, a problem has been remained that a transmission region emerges at an incidence angle larger than the specific angle. With increase in incidence angle, the length of an optical path is longer and an imparted retardation increases. Hence, a property emerges that light is again transmitted at an incidence angle that imparts a retardation of a $\frac{3}{4}$ wavelength. Therefore, if a transmission characteristic is confined only in the front direction, a transmission component is, to the contrary, generated in an oblique direction, which has become a trouble.

[0009] The specification of US 2003/63236 A and the pamphlets of WO 03/27731 A1 and WO 03/27756 A1 all improve a productivity of reflection polarizer laminates for use in transfective by enabling a production according to a roll-to-roll method by use of a rotatory polarizer, as solution of a problem of reduction in productivity and decrease in area yield which have been caused by fabricating the reflection polarizer laminates through lamination having a small displacement in angular registration. In such a general combination of a reflection polarizer-a rotatory plate-a reflection polarizer, there has been no chance that an angular dependency of a transmittance occurs. In a general polarizer using a laminate of a chiral material and a retardation plate such as quartz crystal and saccharose, it is difficult to fabricate the rotatory polarizer, while intentionally controlling a retardation plate having a rotatory polarization characteristic changed by an incidence angle. A TN liquid crystal layer works as a rotatory plate, no phenomenon has been observed that an optical rotation angle varies according to an

incident angle, working as an optical rotator of about 90 degrees in a direction of oblique incidence in a similar way to that in the front direction.

[0010] On the other hand, hologram materials are, in more of cases, expensive, poor in mechanical characteristics, and soft and weak in nature, which have been problematic about long term durability.

[0011] As discussed above, conventional optical elements have been problematic because of difficulty in fabrication, hardness in obtaining a target optical characteristic, poor reliability and the like.

DISCLOSURE OF INVENTION

[0012] The invention is directed to an optical element capable of condensation and collimation of incident light from a light source and it is an object of the invention to provide an optical element capable of suppressing transmission of light in an arbitrary direction.

[0013] It is still another object of the present invention to provide a light condensation backlight system using the optical element and in addition, a liquid crystal display.

[0014] The present inventors have conducted serious studies in order to solve the tasks with the resulted findings of the optical element described below, which has led to completion of this invention. That is, the present invention is as follows:

[0015] 1. An optical element comprising:

[0016] a polarizing element (A), separating incident light into polarization to then emit light, and made of a cholesteric liquid crystal, wherein

[0017] the polarizing element (A) has a distortion rate with respect to emitting light to incident light in the normal direction of 0.5 or more and

[0018] a distortion rate with respect to emitting light to incident light at an angle inclined from the normal direction by 60 degrees or more of 0.2 or less,

[0019] the polarizing element (A) has a function increasing a linearly polarized light component of emitting light as incidence angle is larger;

[0020] a $\frac{1}{2}$ wavelength plate (B);

[0021] a retardation layer (C) giving almost zero retardation to incident light in the front direction (normal direction) and giving a retardation to incident light in a direction inclined from the normal direction; and

[0022] a $\frac{1}{4}$ wavelength plate (D); being arranged in this order,

[0023] and further a linearly polarized light reflection polarizer (E), transmitting linearly polarized light with one polarization axis and selectively reflecting linearly polarized light with the other polarization axis perpendicular to the one polarization axis, is arranged on the $\frac{1}{4}$ wavelength plate (D) so that the transmission axis of the linearly polarized light reflection polarizer (E) and an axis of the transmitted light, which is transmitted through the polarizing element (A) to the $\frac{1}{4}$ wavelength plate (D) in this order, are the same direction.

[0024] 2. The optical element according to the above-mentioned 1, wherein, in the polarizing element (A), the linearly polarized light component of emitting light increasing as incidence angle is larger has a polarization axis of linearly polarized light substantially perpendicular to the normal direction of a surface of the polarizing element.

[0025] 3. The optical element according to the above-mentioned 1, wherein, in the polarizing element (A), the linearly polarized light component of emitting light increasing as incidence angle is larger has a polarization axis of linearly polarized light substantially parallel to the normal direction of a surface of the polarizing element.

[0026] 4. The optical element according to any one of the above-mentioned 1 to 3, wherein the polarizing element (A) substantially reflects a non-transmission component of incident light.

[0027] 5. The optical element according to any one of the above-mentioned 1 to 4, wherein a thickness of the polarizing element (A) is 2 μm or more.

[0028] 6. The optical element according to any one of the above-mentioned 1 to 5, wherein a reflection band width of the polarizing element (A) is 200 nm or more.

[0029] 7. The optical element according to any one of the above-mentioned 1 to 6, wherein the $\frac{1}{2}$ wavelength plate (B) is a broad band wavelength plate working as an almost $\frac{1}{2}$ wavelength plate over the entire visible light band.

[0030] 8. The optical element according to the above-mentioned 7, wherein the $\frac{1}{2}$ wavelength plate (B) has a front retardation values, which is expressed by $(n_x - n_y) \times d$, in the range of a $\frac{1}{2}$ wavelength $\pm 10\%$ at wavelengths in the light source wavelength band (ranging from 420 to 650 nm),

[0031] where a direction in which an in-plane refractive index is maximized is defined as X axis and a direction perpendicular to the X axis is defined as Y axis, where refractive indices in each axis directions are defined as n_x and n_y , respectively, and a thickness is defined as d (nm).

[0032] 9. The optical element according to any one of the above-mentioned 1 to 8, wherein the $\frac{1}{2}$ wavelength plate (B) controls a retardation in the thickness direction and reduces a change in retardation caused by a change in angle.

[0033] 10. The optical element according to the above-mentioned 9, wherein the $\frac{1}{2}$ wavelength plate (B) has an N_z coefficient, which is expressed by $N_z = (n_x - n_z) / (n_x - n_y)$, in a relation of $-2.5 < N_z < 1$,

[0034] where a direction in which an in-plane refractive index is maximized is defined as X axis, a direction perpendicular to the X axis is defined as Y axis and a thickness direction of the film is defined as Z axis, where refractive indices in each axis directions are defined as n_x , n_y and n_z .

[0035] 11 The optical element according to any one of the above-mentioned 1 to 10, wherein the retardation layer (C) is at least one selected from the group consisting of:

[0036] a layer of a cholesteric liquid crystal phase having a selective reflection wavelength band in a range other than the visible light range and having a fixed planar alignment;

[0037] a layer of a rod-like liquid crystal having a fixed homeotropic alignment state;

[0038] a layer of a discotic liquid crystal having a fixed alignment state of a nematic phase or a columnar phase;

[0039] a layer of a biaxially-oriented polymer film;

[0040] a layer of a negative uniaxial inorganic layered compound having an optical axis aligned and fixed in the normal direction of a plane; and

[0041] a film produced with at least one polymer selected from the group consisting of polyamide, polyimide, polyester, poly(etherketone), poly(amide-imide), and poly(ester-imide).

[0042] 12. The optical element according to any one of the above-mentioned 1 to 11, wherein the $\frac{1}{4}$ wavelength plate (D) is a broad band wavelength plate working as an almost $\frac{1}{4}$ wavelength plate over the entire visible light band.

[0043] 13. The optical element according to the above-mentioned 12, wherein the $\frac{1}{4}$ wavelength plate (D) has a front retardation values, which is expressed by $(n_x - n_y) \times d$, in the range of a $\frac{1}{4}$ wavelength $\pm 10\%$ at wavelengths in the light source wavelength band (ranging from 420 to 650 nm),

[0044] where a direction in which an in-plane refractive index is maximized is defined as X axis and a direction perpendicular to the X axis is defined as Y axis, where refractive indices in each axis directions are defined as n_x and n_y , respectively, and a thickness is defined as d (nm).

[0045] 14. The optical element according to any one of the above-mentioned 1 to 13, wherein the $\frac{1}{4}$ wavelength plate (D) has an N_z coefficient, which is expressed by $N_z = (n_x - n_z) / (n_x - n_y)$, in a relation of $-2.5 < N_z < 1$,

[0046] where a direction in which an in-plane refractive index is maximized is defined as X axis, a direction perpendicular to the X axis is defined as Y axis and a thickness direction of the film is defined as Z axis, where refractive indices in each axis directions are defined as n_x , n_y and n_z .

[0047] 15. The optical element according to any one of the above-mentioned 1 to 14, wherein the linearly polarized light reflection polarizer (E) is a grid type polarizer.

[0048] 16. The optical element according to any one of the above-mentioned 1 to 14, wherein the linearly polarized light reflection polarizer (E) is a multilayer thin film laminate with two or more layers made of two or more kinds of materials having a difference between refractive indices.

[0049] 17. The optical element according to the above-mentioned 16, wherein the thin multilayer laminate is a vapor-deposited thin film.

[0050] 18. The optical element according to any one of the above-mentioned 1 to 14, wherein the linearly polarized light reflection polarizer (E) is a multi-birefringence layer thin film laminate with two or more layers made of two or more kinds of materials each having a birefringence.

[0051] 19. The optical element according to the above-mentioned 18, wherein the thin multilayer laminate is a stretched resin laminate with two or more layers containing two or more kinds of resins each having a birefringence.

[0052] 20. The optical element according to any one of the above-mentioned 1 to 19, wherein a polarizing plate is disposed outside of the linearly polarized light reflection polarizer (E) so that the polarized light transmission axis of

the linearly polarized light reflection polarizer (E) and the polarization axis direction of the polarizing plate coincide with each other.

[0053] 21. The optical element according to any one of the above-mentioned 1 to 20, wherein layers are laminated with a transparent adhesive or pressure sensitive adhesive.

[0054] 22. A light condensation backlight system, in which at least a light source is provided for the optical element according to any one of the above-mentioned 1 to 21.

[0055] 23. A liquid crystal display, in which at least a liquid crystal cell is provided for the light condensation backlight system according to the above-mentioned 22.

[0056] 24. The liquid crystal display according to the above-mentioned 23, comprising a diffusing plate neither backscattering nor depolarizing laminated on the viewing side of the liquid crystal cell.

[0057] An optical element of the invention is a combination of a polarizing element (A) separating incident light into polarization to then emit light, and made of a cholesteric liquid crystal, a $\frac{1}{2}$ wavelength plate (B), a retardation layer (C), a $\frac{1}{4}$ wavelength plate (D) and a linearly polarized light reflection polarizer (E), being arranged in this order. In FIG. 13, there is shown an example of a sectional view of an optical element (X) of the invention.

[0058] The optical elements (X) of the invention use a unique phenomenon of the polarizing element (A). That is, the optical elements (X) of the invention use a peculiar characteristic of the polarizing element (A) that an emitting light is linearly polarized if an incidence angle of light increases to a value, but even if an incident angle of light further increases to a larger value, the polarization axis direction of the emitting linearly polarized light does not vary and a polarization state of the emitting light is sustained unchanged, which is combined with the $\frac{1}{2}$ wavelength plate (B), the retardation layer (C), the $\frac{1}{4}$ wavelength plate (D) and the linearly polarized light reflection polarizer (E), wherein emitting light is controlled so as to become a predetermined direction and a secondary transmission component is suppressed.

[0059] In the polarizing element (A) of both cases, a distortion rate with respect to emitting light to incident light in the normal direction is 0.5 or more and circularly polarized light is emitted at an angle of normally incident light or at an incidence angle close to normal incidence. Since the more a distortion rate with respect to emitting light to incident light in the normal direction, the more a proportion of circularly polarized light, a distortion rate is preferably 0.7 or more and more preferably 0.9 or more. On the other hand, a distortion rate with respect to emitting light to incident light at an angle inclined from the normal direction by 60 degrees or more is 0.2 or less and emitting light from incident light at a large incidence angle is linearly polarized light. Since the less a distortion rate with respect to emitting light to incident light at an angle inclined from the normal direction by 60 degrees, the more a proportion of linearly polarized light, a distortion rate of emitting light from the incident angle is preferably 0.2 or less and more preferably 0.1 or less. In such a way, a polarizing element (A) of the invention has a feature that the more an incident angle, the more a proportion of linearly polarized light component of emitting light.

[0060] An example of the polarizing element (A) can be a polarizing element with which a linearly polarized light component of emitting light that increases as an incidence angle is larger has the polarization axis of linearly polarized light in a direction substantially perpendicular to the normal direction of a surface of the polarizing element. FIG. 1(A) is a conceptual representation showing that emitting light (e) transmitted through a polarizing element (A1), which is in an optical plane (the x axis-y axis plane), has a different polarized light component according to a difference of an incidence angle of incident light (i). FIG. 1(B) is a conceptual diagram when emitting light (e) is viewed along the z axis direction. Note that in FIG. 3, there is shown various kinds of light of linearly polarized light (i), natural light (ii), circularly polarized light (iii) and elliptically polarized light (iv).

[0061] Emitting light (e1) is emitting circularly polarized light from incident light (i1) in the z axis direction (the normal direction) to the polarizing element (A1).

[0062] Emitting light (e2) and (e4) is emitting elliptically polarized light from incident light (i2) and (i4) obliquely to the polarizing element (A1). The emitting light (e2) is present on a plane including the z axis and the y axis and is an elliptically polarized light having an axis perpendicular to the plane including the axes. The emitting light (e4) is present on the plane including the z axis and the x axis and is an elliptically polarized light having an axis perpendicular to the plane including axes.

[0063] Emitting light (e3) and (e5) is emitting linearly polarized light from incident light (i3) and (i5) obliquely to the polarizing element (A1) at a large angle. The emitting light (e3) is present on a plane including the z axis and the y axis and is a linearly polarized light having an axis perpendicular to the plane including the axes. The emitting light (e5) is present on the plane including the z axis and the x axis and is a linearly polarized light having an axis perpendicular to the plane including axes. The emitting light (e3) and (e5), which is linearly polarized light, has, in such a way, the polarization axes substantially perpendicular to the z axis, that is the polarization axes in parallel with an optical plane (the x axis-y axis plate).

[0064] An example of the polarizing element (A) can be a polarizing element with which a linearly polarized light component of emitting light which increases as an incidence angle is larger has the polarization axis of linearly polarized light in a direction substantially parallel to the normal direction of a surface of the polarizing element. FIG. 2(A) is a conceptual representation showing that emitting light (e) transmitted through a polarizing element (A2), which is in an optical plane (the x axis-y axis plane), has a different polarized light component according to a difference of an incidence angle of incident light (i). FIG. 2(B) is a conceptual diagram when emitting light (e) is viewed along the z axis direction.

[0065] Emitting light (e41) is emitting circularly polarized light from incident light (i41) in the z axis direction (the normal direction) to the polarizing element (A2).

[0066] Emitting light (e42) and (e44) is emitting elliptically polarized light from incident light (i42) and (i44) obliquely to the polarizing element (A2). The emitting light (e42) is present on a plane including the z axis and the y axis

and an elliptically polarized light having an axis parallel to the plane including the axes. The emitting light (e44) is present on the plane including the z axis and the x axis and is an elliptically polarized light having an axis parallel to the plane including axes.

[0067] Emitting light (e43) and (e45) is emitting linearly polarized light from incident light (i43) and (i45) obliquely striking the polarizing element (A2) at a large angle. The emitting light (e43) is present on a plane including the z axis and the y axis and is a linearly polarized light having an axis parallel to the plane including the axes. The emitting light (e45) is present on the plane including the z axis and the x axis and is a linearly polarized light having an axis parallel to the plane including the axes. The emitting linearly polarized light (e43) and (e45), which is a linearly polarized light, has, in such a way, the polarization axes substantially parallel to the z axis, that is the polarization axes perpendicular to a optical plane (the x axis-y axis plane).

[0068] The polarizing element (A) is formed of a cholesteric liquid crystal layer. A reflection band width of the polarizing element is preferably 200 nm or more. It has conventionally understood that circularly polarized light is transmitted through/reflected on a cholesteric liquid crystal layer regardless of an incidence angle. Refer to FIG. 4. In a conventional single pitch narrow band cholesteric liquid crystal layer (a1), emitting light actually has been circularly polarized light regardless of an incidence angle of incident light. The present invention uses a discovered phenomenon that a cholesteric liquid crystal layer having a broad band selective reflection wavelength band transmits linearly polarized light in a case where an incidence angle of incident light is large as described above. That is, the phenomenon is not observed in a single pitch cholesteric liquid crystal layer exerting a selective reflection function at a specific wavelength only, but observed only in a cholesteric liquid crystal layer having a varying pitch length covering a broad band.

[0069] Note that in the past, a report was made by TAKEZOE (Jpn. J. Appl. Phys., 22 1080 (1983)) on a phenomenon that in a case where a cholesteric liquid crystal layer large in birefringence is aligned to a thickness as large as tens of μm (a2), incident light with a large incidence angle is totally reflected without transmission. Refer to FIG. 5. In the literature, however, no description is given of the fact that incident light with a large incidence angle is linearly polarized.

[0070] A polarizing element (A) generating the above phenomenon can be obtained, for example, by laminating cholesteric liquid crystal layers having central wavelengths different from one another to thereby obtain a cholesteric liquid crystal layer having a selective reflection wavelength band covering the entire visible region. Refer to FIG. 6. In FIG. 6, there is shown a case where three layers in colors R (a red wavelength region), G (a green wavelength region) and B (a blue wavelength region) are laminated. A construction can be used in which a twist pitch length of a cholesteric liquid crystal layer varies along the thickness direction to thereby render a band broader. Refer to FIG. 7. A polarizing element exerting the above phenomenon, in such a way, may be a laminate of plural cholesteric liquid crystal layers, as shown in FIG. 6, having selective reflection wavelength bands different from one another and can also be a chole-

teric liquid crystal layer in which a pitch length, as shown in FIG. 7, continuously alters in the thickness length, both of which exhibit similar effects.

[0071] The reason for generation of the phenomenon is not clear. Even a single pitch cholesteric liquid crystal layer must create linearly polarized light with a specific wavelength in a case where a separating light into polarization is affected simply by using a Brewster's angle at interfaces between liquid crystal layers. Since there is no difference between a laminate of cholesteric liquid crystal layers and a cholesteric liquid crystal layer in which a pitch length is continuously alters in the thickness direction, the phenomenon is not a reflection effect at interfaces of the laminate either. Therefore, the phenomenon is, it is thought, that circularly polarized light separated when light is transmitted through a cholesteric liquid crystal layer is imparted a retardation in the next cholesteric liquid crystal layer having a wavelength band different from the former and is thereby converted to linearly polarized light.

[0072] In order to effectively generate the phenomenon to work, a selective reflection band width is necessary to be sufficiently broad and desirably 200 nm or more, more desirably 300 nm or more and further more desirably 400 nm or more. In order to cover the visible light region, it is necessary to cover, to be concrete, the range of from 400 to 600 nm in wavelength. Note that since a selective reflection wavelength shifts to the shorter wavelength side so as to be adapted for an incidence angle, it is desirable to extend a selective selection wavelength band to the longer wavelength side thereof in order to cover the visible light region independently of an incidence angle, to which limitation is not necessarily imposed on.

[0073] In order to generate the phenomenon that a polarizing element of the invention effectively works, a cholesteric liquid crystal layer is preferably sufficiently thick. In a case of a single pitch cholesteric liquid crystal layer, a thickness thereof generally can give a sufficiently selective reflection with a value of the order of a few pitches (twice or thrice times as long as the central wavelength of selective reflection). With a central wavelength of selective reflection in the range of 400 to 600 nm adopted, a thickness thereof on the order in the range of from 1 to 1.5 μm works as a polarizing element due to a refractive index of a cholesteric liquid crystal. Since a cholesteric liquid crystal used in a polarizing element of the invention has a broad reflection band, a thickness thereof is preferably 2 μm or more. A thickness thereof is more preferably 4 μm or more and further more preferably 6 μm or more.

[0074] In order to obtain a polarizing element (A), it is preferable to use such a broad band cholesteric liquid crystal that a selective reflection band thereof covers the visible light band. This is because a broad band cholesteric liquid crystal layer is thick enough to thereby enable a retardation to be imparted effectively.

[0075] A polarizing element (A) obtains circularly polarized light from incident light in the front direction (the normal direction) and emits linearly polarized light in a direction perpendicular to or parallel to the normal from incident light at a large incidence angle. Therefore, sufficient extension of a selective reflection wavelength band to the longer wavelength side renders a reflectance in the visible light band unchanged and enables the polarizing element (A)

to work so that an image is visually recognized as in a mirror surface reflective member without a change in tone.

[0076] An optical element (X) of the invention has a construction in which, as shown in FIG. 13, a polarizer (A), a $\frac{1}{2}$ wavelength plate (B), a retardation layer (C), a $\frac{1}{4}$ wavelength plate (D) and a linearly polarized light reflection polarizer (E) are laminated in the order, and incident light is transmitted in the order therethrough. Description will be given of a case where a polarizer (A1) is used as the polarizer (A).

[0077] Note that in FIG. 15, there is shown conceptual representations in each of which polarized light alters by the action of a wavelength plate. A symbol F indicates a fast axis and a symbol S indicates a slow axis. FIGS. 15-1 and 15-2 shows conversion from linearly polarized light to circularly polarized light using a $\frac{1}{4}$ wavelength plate. FIGS. 15-3 and 15-4 shows conversion from circularly polarized light to linearly polarized light using a $\frac{1}{4}$ wavelength plate. FIGS. 15-5 and 15-6 shows conversion in an axis direction or a sense of rotation using a $\frac{1}{2}$ wavelength plate.

[0078] Emitting light beams from a polarizing plate (A1) are as in ways shown in FIG. 1. When emitting light transmitted through the polarizing element (A1) is transmitted through the $\frac{1}{2}$ wavelength plate (B), as shown in FIG. 10 circularly polarized light in the front direction (the normal direction) is circularly polarized light with a reversed sense of rotation and a linearly polarized light transmitted in an oblique direction rotates the polarization axis direction by 90 degrees (see FIGS. 15-5 and 15-6).

[0079] Emitting light (e11) is present on the z axis. The emitting light (e11) corresponds to the emitting light (e1) normally transmitted through the polarizing element (A1). The emitting light (e11) is circularly polarized light affected by a retardation in the $\frac{1}{2}$ wavelength plate (B) and thereby, a sense of rotation thereof is reversal of the sense of rotation of the emitting light (e1).

[0080] Emitting light (e12) is light obtained after the emitting light (e2) is affected by a retardation of the $\frac{1}{2}$ wavelength plate (B) and an axis angle is rotated by 90 degrees. The emitting light (e12) is elliptically polarized light having the axis parallel to the plane including the z axis and the y axis.

[0081] Emitting light (e13) is light obtained after the emitting light (e3) is affected by a retardation of the $\frac{1}{2}$ wavelength plate (B) and an axis angle is rotated by 90 degrees. The emitting light (e13) is linearly polarized light having an axis parallel to the plane including the z axis and the y axis.

[0082] Emitting light (e14) is light obtained after the emitting light (e4) is affected by a retardation of the $\frac{1}{2}$ wavelength plate (B) and an axis angle is rotated by 90 degrees. The emitting light (e14) is elliptically polarized light having an axis parallel to the plane including the z axis and the x axis.

[0083] Emitting light (e15) is light obtained after the emitting light (e5) is affected by a retardation of the $\frac{1}{2}$ wavelength plate (B) and an axis angle is rotated by 90 degrees. The emitting light (e15) is linearly polarized light having an axis parallel to the plane including the z axis and the x axis.

[0084] Then, emitting light transmitted through a $\frac{1}{2}$ wavelength plate (B) is further transmitted through a retardation layer (C). The retardation layer (C) has the front retardation (normal direction) of almost zero and emitting light in the front direction does not change a polarization state thereof. On the other hand, the retardation layer (C) gives retardation to incident light inclined relative to the normal direction; therefore, linearly polarized light is changed to circularly polarized light. In FIG. 9, there is shown emitting light transmitted through the polarizer (A1), the $\frac{1}{2}$ wavelength plate (B) and the retardation layer (C) in the order.

[0085] Emitting light (e21) exists on the z axis. The emitting light (e21) is emitting light when emitting light (e11) is transmitted through the retardation layer (C) in the normal direction thereof. Since the retardation layer (C) has the front retardation of almost zero, the emitting light (e21) is circularly polarized light similar to the emitting light (e11).

[0086] Emitting light (e22) exists on a plane including the z axis and the y axis. Emitting light (e22) is emitting light when emitting light (e12) is transmitted through the retardation layer (C) in an oblique direction. The emitting light (e22) is changed to circularly polarized light with the rotational direction reverse to that of the emitting light (e12) by a retardation of the retardation layer (C).

[0087] Emitting light (e23) exists on a plane including the z axis and the y axis. The emitting light (e23) is emitting light when emitting light (e13) is transmitted through the retardation layer (C) in an oblique direction. The emitting light (e23) is changed to circularly polarized light with the rotational direction reverse to that of the emitting light (e12) by a retardation of the retardation layer (C).

[0088] Emitting light (e24) exists on a plane including the z axis and the x axis. The emitting light (e24) is emitting light when emitting light (e14) is transmitted through the retardation layer (C) in an oblique direction. The emitting light (e24) is changed to circularly polarized light with the rotational direction reverse to that of the emitting light (e14) by a retardation of the retardation layer (C).

[0089] Emitting light (e25) exists on a plane including the z axis and the x axis. The emitting light (e25) is emitting light when emitting light (e14) is transmitted through the retardation layer (C) in an oblique direction. The emitting light (e25) is circularly polarized light with the rotational direction reverse to that of the emitting light (e14) by a retardation of the retardation layer (C).

[0090] Then, emitting light transmitted through the retardation layer (C) is further transmitted through a $\frac{1}{4}$ wavelength plate (D). The $\frac{1}{4}$ wavelength plate (D) can change circularly polarized light emitted from the retardation layer (C) to linearly polarized light (see FIG. 15-5 and 15-6). The $\frac{1}{4}$ wavelength plate (D) is preferably placed so that an axis direction thereof makes an angle of the about 45 degrees relative to the x axis and the y axis. Note that an axis angle preferably resides in the range of 45 degrees \pm 5 degrees. In FIG. 10, there is shown emitting light transmitted through the polarizing element (A1), the $\frac{1}{2}$ wavelength plate (B), the retardation layer (C) and the $\frac{1}{4}$ wavelength plate (D) in the order.

[0091] Emitting light (e31) exists on the z axis. The emitting circularly polarized light (e31) is linearly polarized

light, which is changed from emitting circularly polarized light (e21) by the $\frac{1}{4}$ wavelength plate (D), having a polarization direction in the y axis direction

[0092] Emitting light (e32) exists on a plane including the z axis and the y axis. The emitting light (e32) is linearly polarized light, which is changed from emitting circularly polarized light (e22) by a $\frac{1}{4}$ wavelength plate (D), having a polarization direction in the x axis direction.

[0093] Emitting light (e33) exists on a plane including the z axis and the y axis. The emitting light (e33) is linearly polarized light, which is changed from emitting circularly polarized light (e23) by a $\frac{1}{4}$ wavelength plate (D), having a polarization direction in the x axis direction.

[0094] Emitting light (e34) exists on a plane including the z axis and the x axis. The emitting light (e34) is linearly polarized light, which is changed from emitting circularly polarized light (e24) by a $\frac{1}{4}$ wavelength plate (D), having a polarization direction in the y axis direction.

[0095] Emitting light (e35) exists on a plane including the z axis and the y axis. The emitting light (e35) is linearly polarized light, which is changed from emitting circularly polarized light (e25) by a $\frac{1}{4}$ wavelength plate (D), having a polarization direction in the y axis direction.

[0096] Then, emitting light transmitted through the retardation layer (C) is further transmitted through a linearly polarized light reflection polarizer (E). The linearly polarized light reflection polarizer (E) transmits linearly polarized light with one polarization axis and selectively reflecting linearly polarized light with the other polarization axis perpendicular to the one polarization direction. FIG. 8 is a conceptual diagram showing that emitting light (e51 to e55) transmitted through the linearly polarized light reflection polarizer (E) having an optical plane (an x axis-y axis plane) emits as linearly polarized light in the same polarization direction regardless of an incidence angle of incident light (i). In FIG. 8, the transmission axis exists in the y axis direction and the reflection axis exists in the x axis direction. Note that in FIG. 8, there is not shown incident light (i). Besides, the linearly polarized light having a polarization direction perpendicular to a polarization direction of emitting light (e) is reflected.

[0097] The linearly polarized light reflection polarizer (E) is arranged so that the transmission axis thereof an axis of the transmitted light, which is transmitted through the polarizing element (A) to the $\frac{1}{4}$ wavelength plate (D) in this order, are the same direction. In FIG. 10, the linearly polarized light reflection polarizer (E) is arranged so that the y axis serves as the transmission axis thereof. In FIG. 10, there are shown emitting light transmitted through the polarizing element (A1), the $\frac{1}{2}$ wavelength (B), the retardation layer (C), the $\frac{1}{4}$ wavelength plate (D) and the linearly polarized light reflection polarizer (E) in the order, that is transmitted light through an optical element (X) of the invention.

[0098] Emitting light (e61) exists on the z axis. The direction of the polarization axis of emitting linearly polarized light (e31) and the transmission axis of the linearly polarized light reflection polarizer (E) are both parallel to the y axis and linearly polarized light is emitted as is in the polarization state prior to transmission.

[0099] Non-emitting light (e62) exists on the plane including the z axis and the y axis. The emitting linearly polarized

light (e32) is all reflected and shielded by the linearly polarized light reflection polarizer (E). This is because the direction of the polarization axis of emitting linearly polarized light (32) is in the y axis, while the direction of the transmission axis of the linearly polarized light reflection polarizer (E) is in the x axis and an angle formed between both linearly polarized light axes makes a perpendicular relationship.

[0100] Non-emitting light (e63) exists on the plane including the z axis and the y axis. The emitting linearly polarized light (e33) is all reflected and shielded by the linearly polarized light reflection polarizer (E). This is because the direction of the polarization axis of emitting linearly polarized light (33) is in the y axis, while the direction of the transmission axis of the linearly polarized light reflection polarizer (E) is in the x axis and an angle formed between both linearly polarized light axes makes a perpendicular relationship.

[0101] Emitting light (e64) exists on the plane including the z axis and the x axis. The direction of the polarization axis of emitting linearly polarized light (e34) and the transmission axis of the linearly polarized light reflection polarizer (E) are both parallel to the y axis and linearly polarized light is emitted as is in the polarization state prior to transmission.

[0102] Emitting light (e65) exists on the plane including the z axis and the x axis. The polarization direction of emitting linearly polarized light (35) and the transmission axis of the linearly polarized light reflection polarizer (E) are both parallel to the y axis and linearly polarized light is emitted as is in the polarization state prior to transmission.

[0103] In FIG. 9, there is illustrated a case where the polarizing element (A1) is employed as a polarizing element (A), while in a case where the polarizing element (A2) is employed as a polarizing element (A), there can be obtained emitting light beams having a relationship between the x axis and the y axis, which is a reversal of the relationship thereof shown in FIG. 9.

[0104] Incident light to an optical element (X) in the front direction (normal direction) is, as described above, transmitted through the polarizing element (A), the $\frac{1}{2}$ wavelength plate (B) and the retardation layer (C) as circularly polarized light with the same rotational direction, while being changed to linearly polarized light by the $\frac{1}{4}$ wavelength plate (D). Moreover, the linearly polarized light is transmitted as is in the polarization state prior to transmission through the linearly polarized light reflection polarizer (E) placed so that the transmission axis thereof is the same as the polarization axis of the linearly polarized light. On the other hand, incident light to an oblique direction is transmitted through the polarizing element (A), thereafter changed to linearly polarized light having the polarization axis direction rotated by 90 degrees by the $\frac{1}{2}$ wavelength plate (B), and then further changed to circularly polarized light by the retardation layer (C). Since the light is further changed to linearly polarized light having the polarization direction rotated by 90 degrees by the $\frac{1}{4}$ wavelength plate (D), the linearly polarized lights are reflected and shielded by the linearly polarized light reflection polarizer (E). With the polarizing element (A1) and the linearly polarized light reflection polarizer (E) sufficiently high in polarization degree, highly efficient linearly polarized light can be obtained with a small absorption loss.

[0105] The optical element (X), since linearly polarized light can be obtained as emitting light, has a function in which improvement on brightness and condensation are achieved with compatibility by placing the optical element (X) on the light source side of a liquid crystal display. Besides, since the optical element (X) has substantially no absorption loss, incident light beams at an angle at which the light beams do not enter into the liquid crystal display are all reflected to the light source side for recycling. This is because an exit of emitted light beams in an oblique direction from a light source is present only in the front direction to thereby substantially condense the light beams.

[0106] An optical element (X) of the invention can have a condensation characteristic reflecting only an arbitrary direction to condense light beams in necessary azimuth including the front. To be concrete, since a notebook personal computer having a liquid crystal display as indispensable requires light beams in the lateral direction but does not require light in the direction, from top to bottom, an optical element (X) of the invention can be preferably employed in application thereof.

[0107] Generally, it is possible to condense light beams in all directions into the front direction by disposing a prism sheet on a surface light source. A laminate of two kinds of prism sheets has been conventionally used in more of cases, wherein a longitudinal prism sheet, as one, for condensing light beams in lateral directions (from left to right) into the front and a lateral prism sheet, as the other, for condensing light beams in longitudinal directions (from top to bottom) into the front. According to the invention, the two prism sheets can be removed or only one thereof can be used.

[0108] According to the invention, a characteristic that have been unable to be acquired from a conventional optical element can be easily realized. The use of an optical element of the invention makes it possible to obtain an optical element having a high transmittance in the front direction and a good shielding direction effect in an oblique direction, and having no absorption loss together with a selective reflection characteristic of a cholesteric liquid crystal. Precise adjustment on secondary transmission in an oblique direction and a wavelength characteristic is unnecessary to thereby enable a stable performance to be attained.

[0109] Since an optical element of the present invention does not require an air interface, which is dissimilar to cases of a conventional lens sheet or a prism sheet, it can be used as a laminate in single piece obtained by adhering itself to a polarizing plate, and is also useful in handleability. A great effect is exerted in realizing a thin type. Since the optical element has no regularity structure visually recognizable as in a prism structure, a moiré or the like is hard to occur and has advantages in removal of a diffusing plate or the like decreasing a total light transmittance, or realization of low haze (a total light transmittance is generally increased) with ease. It is naturally not problematical to use the optical element together with a prism sheet or the like. For example, a steep condensation on to the front is performed with a prism sheet or the like, wherein a secondary transmission peak caused by the prism sheet at a large emission angle can be preferably shielded with an optical element of this invention used in combination.

[0110] In a conventional backlight device using only a prism sheet, a direction of emission light peak has a ten-

gency that the direction of emission light peak moves away from a light source cold cathode fluorescent lamp. This is because more of light emitted from a light guide plate in an oblique direction is emitted in a direction moving away from the light source cold cathode fluorescent lamp and it is difficult to position peak intensity in the normal direction to the screen. In contrast thereto, by using an optical element according to the present invention, an emission peak is enabled to coincide with the front direction with ease.

[0111] A combination of a light condensation backlight source using the optical element and a diffusing plate low in backscattering and generating no cancellation of polarization enables construction of a viewing angle magnification system to be built.

[0112] A light condensation backlight system using the optical element having been obtained in this way easily provides a light source higher in light collimation as compared with a conventional practice. Since, in addition, light collimation due to reflective polarization essentially having no absorption loss can be obtained, a reflected non-collimated light component is returned back to the backlight side and recycling during which only a collimated light component is extracted by scattering reflection is repeated, thereby enabling substantially high transmittance and substantially high light utilization efficiency to be obtained.

BRIEF DESCRIPTION OF DRAWINGS

[0113] FIG. 1(A) is a conceptual representation showing the polarization axis directions of emitting light beams transmitted through a polarizing element (A1).

[0114] FIG. 1(B) is a conceptual representation showing the polarization axes of emitting light beams when FIG. 1(A) is viewed along the normal direction of the polarizing element (A1).

[0115] FIG. 2(A) is a conceptual representation showing the polarization axis directions of emitting light beams transmitted through a polarizing element (A2).

[0116] FIG. 2(B) is a conceptual representation showing the polarization axes of emitting light beams when FIG. 2(A) is viewed along the normal direction of the polarizing element (A2).

[0117] FIG. 3 is conceptual diagrams describing polarized light components and others.

[0118] FIG. 4 is a conceptual representation showing separating light into polarization with a conventional cholesteric liquid crystal layer.

[0119] FIG. 5 is a conceptual representation showing separating light into polarization with a conventional cholesteric liquid crystal layer.

[0120] FIG. 6 is a conceptual representation showing separating light into polarization with a polarizing element (A).

[0121] FIG. 7 is conceptual representation showing separating light into polarization with a polarizing element (A).

[0122] FIG. 8 is a conceptual representation showing the polarization axis directions of emitting light beams transmitted through the polarizing plate (A1) and then through a $\frac{1}{2}$ wavelength plate (B).

[0123] FIG. 9 is a conceptual representation showing the polarization axis directions of emitting light beams transmitted through the polarizing plate (A1), the $\frac{1}{2}$ wavelength plate (B) and then through a retardation layer (C).

[0124] FIG. 10 is a conceptual representation showing the polarization axis directions of emitting light beams transmitted through the polarizing plate (A1), the $\frac{1}{2}$ wavelength plate (B), the retardation layer (C) and then through a $\frac{1}{4}$ wavelength plate (D).

[0125] FIG. 11 is a conceptual representation showing the polarization axis directions of emitting light beams transmitted through a linearly polarized light reflection polarizer (E) only.

[0126] FIG. 12 is a conceptual representation showing the polarization axis directions of emitting light beams transmitted through the polarizing plate (A1), the $\frac{1}{2}$ wavelength plate (B), the retardation layer (C), the $\frac{1}{4}$ wavelength plate (D) and then through the linearly polarized light reflection polarizer (E).

[0127] FIG. 13 is an example of a sectional view of an optical element (X) of the invention.

[0128] FIG. 14 is an example of a sectional view in a case where a polarizing plate (P) is laminated on an optical element (X) of the invention.

[0129] FIG. 15 is conceptual representation showing conversion in kind of polarized light with a wavelength plate.

[0130] FIG. 16 is an example of a sectional view of a liquid crystal display using the optical element (X) of the invention.

[0131] FIG. 17 is an example of a sectional view of a liquid crystal display using the optical element (X) of the invention.

[0132] FIG. 18 is an example of a sectional view of a liquid crystal display using the optical element (X) of the invention.

[0133] FIG. 19 is an example of a sectional view of a liquid crystal display using the optical element (X) of the invention.

[0134] FIG. 20 is a graph showing a transmitted light intensity angular distribution of an optical element (X1) of Example 1.

[0135] FIG. 21 is a graph showing a transmitted light intensity angular distribution of an optical element (X2) of Example 2.

[0136] FIG. 22 is a graph showing a transmitted light intensity angular distribution of an optical element (X3) of Example 3.

[0137] FIG. 23 is a graph showing a transmitted light intensity angular distribution of a polarizing element of Comparative Example 1.

[0138] FIG. 24 is a graph showing a transmission spectrum of a band pass filter of Comparative Example 2.

[0139] FIG. 25 is a graph showing a condensation state of a band pass filter of Comparative Example 2.

[0140] FIG. 26 is a graph showing a transmission spectrum of a band pass filter of Comparative Example 3.

[0141] FIG. 27 is a graph showing a transmitted light intensity angular distribution of a liquid display of Comparative Example 4.

BEST MODE FOR CARRYING OUT THE INVENTION

[0142] A polarizing element (A) of the invention can be formed of a cholesteric liquid crystal layer with a reflection band width of 200 nm or more. The cholesteric liquid crystal layer can be formed with plural cholesteric liquid crystal layers having selective reflection bands different from one another. A polarizing element (A) of the invention can be, as described above, formed of a cholesteric liquid crystal layer in which a pitch length continuously varies in the thickness direction. Note that as shown in the polarizing element (A1) of FIG. 1 or the polarizing element (A2) of FIG. 2, cholesteric liquid crystal layers are properly selected in order control (in order to control the polarization axes of oblique emitting light).

[0143] A difference in axis direction of linearly polarized light in oblique transmitted light as in the polarization element (A1) and the polarization element (A2) can be controlled in an arbitrary way by a difference in order of lamination of the cholesteric liquid crystal layers or a difference in manufacturing method. In a case of a polarizing element causing separating light into polarization with a Brewster's angle adopted, which is general, transmitted light in an oblique direction is specifically defined and only a linearly polarized light having the polarization axis substantially parallel to the normal of an optical plane is obtained. A selective reflection width wavelength band of the polarizing element (A) preferably includes at least a wavelength of 550 nm.

(Lamination of Cholesteric Liquid Crystal Layers)

[0144] In a case where a polarizing element is a laminate of plural cholesteric liquid crystal layers having selective reflection bands different from one another, each of the plural cholesteric liquid crystal layers is laminated by properly selecting the plural cholesteric liquid crystal layers so that a reflective reflection band width thereof is 200 nm or more.

[0145] A proper cholesteric liquid crystal may be used as a cholesteric liquid crystal layer without imposing any specific limitation. Examples thereof that are named include: a liquid crystal polymer exhibiting a cholesteric liquid crystallinity at a high temperature; a polymerized liquid crystal obtained by polymerizing a liquid crystal monomer, and a chiral agent and an alignment agent, when both are required, with illumination of ionizing radiation such as an electron beam, ultraviolet or the like, or with heating; and a mixture thereof. While a liquid crystallinity may be either lyotropic or thermotropic, a thermotropic liquid crystal is desirable from the view point of ease of control and formability of monodomain.

[0146] Formation of a cholesteric liquid crystal layer can be performed by means of a method in conformity with a conventional alignment treatment. Exemplified are: a method in which a liquid crystal polymer is developed on a proper alignment film selected from the group: an alignment film obtained by being subjected to a rubbing treatment with a rayon cloth or the like on a film made of polyimide,

polyvinyl alcohol, polyester, polyarylate, polyamide imide, polyether imide or the like formed on a support base material having as low a birefringence retardation as possible such as triacetyl cellulose, amorphous polyolefin or the like; an alignment film made of an obliquely evaporated layer made of SiO₂; an alignment film made of a base material using a surface nature and state of a stretched base material such as polyethylene terephthalate, polyethylene naphthalate or the like; an alignment film made of a base material with fine surface irregularity of projections and depressions having a fine alignment control force formed thereon obtained by treating a surface thereof with a fine grinding agent represented by a rubbing cloth or red iron oxide; an alignment film made of a base material having an alignment film producing a liquid crystal control force by illuminating an azobenzene compound or the like on a base material film described above with light formed thereon; and others, and the liquid crystal polymer is heated at a temperature of a glass transition temperature or higher and lower than an isotropic phase transition temperature and cooled at a temperature lower than the glass transition temperature in a planar alignment state of the liquid crystal polymer molecules into a glassy state to thereby form a fixed layer in which the alignment is fixed; and other methods. A structure may also be fixed by illuminating with energy such as ultraviolet, an ion beam or the like at a stage where an alignment state is established.

[0147] Film formation of a liquid crystal polymer can be performed by means of a method in which a liquid crystal polymer is developed into a thin film using a solution of the liquid crystal polymer with a solvent with one of the following techniques: such as a spin coating method; a roll coating method, a flow coating method; a printing method; a dip coating method; a flow film forming method; a bar coating method; a gravure printing method and others, to further dry the thin film, when required. Examples of the solvent that can be properly used include: chlorine containing solvents such as methylene chloride, trichloroethylene and tetrachloroethane; ketone solvents such as acetone, methyl ethyl ketone and cyclohexanone; aromatic solvents such as toluene; cycloalkanes such as cycloheptane; and N-methylpyrrolidone, tetrahydrofuran and others.

[0148] One of methods can be adopted in which a heat-melt of a liquid crystal polymer and preferably a heat-melt in a state exhibiting an isotropic phase is developed in a procedure in conformity with a procedure as described above, the developed film is further developed to a thinner film while a melting temperature is maintained, if necessary, and the thinner film is then solidified. The one method is a method using no solvent; therefore, a liquid crystal polymer can be developed by a method good in hygiene in a working environment as well.

[0149] Note that in development of a liquid crystal polymer, there can be adopted a superimposition scheme for cholesteric liquid crystal layers with alignment films interposed between layers for the purpose to realize a thinner, if necessary. The obtained cholesteric liquid crystal layers can also be separated from a support base material/an alignment base material therefore used in film formation and transferred onto another optical material for use when required.

[0150] As laminating methods for cholesteric liquid crystal layers, exemplified are a method in which plural cholesteric

teric liquid crystal layers prepared separately are adhered to each other with an adhesive or a pressure-sensitive adhesive, a method for contact bonding cholesteric liquid crystal layers with each other after surfaces thereof are swollen or dissolved with a solvent or the like and a method for contact bonding cholesteric liquid crystal layers in heating or under an influence of supersonic wave. In addition, a method can be used in which after a cholesteric liquid crystal layer is prepared, cholesteric liquid crystal layers having different selective reflection central wavelength are superimposed.

(Cholesteric Liquid Crystal Layer in which Pitch Length Varies Continuously in Thickness Direction)

[0151] A cholesteric liquid crystal layer in which a pitch length varies continuously in the thickness direction is manufactured by means of a method in which a composition containing a liquid crystal monomer similar to that as described above is employed and the composition is irradiated with an ionizing radiation such as an electron beam or ultraviolet as described below. To be concrete, the following methods are exemplified: a method in which a difference in polymerization speed due to a difference in ultraviolet transmittance in the thickness direction (JP-A No. 2000-95883), a method in which extraction is conducted with a solvent to form a concentration gradient in the thickness direction (JP No. 3062150), a method in which a temperature is varied after a first polymerization and second polymerization is effected at a newly set temperature (U.S. Pat. No. 6,057,008) and the like.

[0152] A method is further preferably used, in which a step of coating a liquid crystal mixture containing a polymerizable mesogen (a) and a polymerizable chiral agent (b) on an alignment substrate and a step of irradiating the coat with ultraviolet from the substrate side in a state where the liquid crystal mixture in the coat is in contact with a gas containing oxygen to thereby polymerize and cure the coat are applied, and then a difference in polymerization speed in the thickness direction due to polymerization hindrance by oxygen increases by irradiation with ultraviolet from the substrate side (JP-A No. 2000-139953).

[0153] In connection with the method described in JP-A No. 2000-139953, a cholesteric liquid crystal layer with a broader reflection wavelength band can be obtained in a method described below.

[0154] For example, the latter method, as the ultraviolet polymerization, includes, as the ultraviolet polymerization step: a first step (1) of irradiating the liquid crystal mixture with ultraviolet from the alignment substrate side at an ultraviolet irradiation intensity in the range of from 20 to 200 mW/cm² at a temperature of 20° C. or higher for a time in the range of 0.2 to 5 sec in a state where the liquid crystal mixture is in contact with a gas containing oxygen, a second step (2) of heating the liquid crystal layer at a temperature in the range of from 70 to 120° C. for 2 sec or longer in a state where the liquid crystal layer is in contact with the gas containing oxygen, a third step (3) of irradiating the liquid crystal mixture with ultraviolet from the alignment substrate side at an ultraviolet irradiation intensity lower than that in the first step (1) at a temperature of 20° C. or higher for a time of 10 sec or longer in a state where the liquid crystal layer is in contact with a gas containing oxygen and a fourth step (4) of irradiating the liquid crystal layer with ultraviolet in the absence of oxygen (JP-A No. 2003-93963).

[0155] A method can be exemplified, as the ultraviolet polymerization, including a first step (1) of irradiating the liquid crystal mixture with ultraviolet from the substrate side three times or more at an ultra violet irradiation intensity in the range of 1 to 200 mW/cm² at a temperature of 20° C. or higher for a time in the range of from 0.2 to 30 sec, wherein irradiation with ultraviolet in the range of the intensity is reduced and a time of ultraviolet irradiation is longer each time the irradiation is effected while times of irradiation is increased, and a second step (2) of irradiating the liquid crystal layer with ultraviolet in the absence of oxygen (JP-A No. 2003-94307).

[0156] A method can be exemplified, as the ultraviolet polymerization, including a first step (1) of irradiating the liquid crystal mixture with ultraviolet from the substrate side at an ultra violet irradiation intensity in the range of 20 to 200 mW/cm² at a temperature of 20° C. or higher for a time in the range of from 0.2 to 5 sec in a state where the liquid crystal mixture is in contact with a gas containing oxygen, and a second step (2) of irradiating the liquid crystal layer with ultraviolet from the substrate side at an ultraviolet irradiation intensity lower than that in the first step at a temperature higher than that in the first step (1) with a temperature rise rate of 2° C./min or more till a temperature reaches a temperature higher than that in he first step (1) and 60° C. or higher for a time of 10 sec or longer in a state where the liquid crystal layer is in contact with a gas containing oxygen and a third step (3) of irradiating the liquid crystal layer with ultraviolet in the absence of oxygen (JP-A No. 2003-94605).

[0157] Besides, the following method can be employed. In the method, a cholesteric liquid crystal layer, having a broad band reflection wavelength band and good in heat resistance can be obtained. For example, a liquid crystal mixture containing a polymerizable mesogen (a), a polymerizable chiral agent (b) and a photopolymerization initiator (c) is polymerized by irradiation with ultraviolet between two substrates (JP-A Nos. 2003-4346 and 2003-4101). A method is further exemplified in which a polymerizable ultraviolet absorbent (d) is further added to the liquid crystal mixture and the liquid crystal mixture is polymerized with ultraviolet between two substrates (JP-A No. 2003-4298). A method is further exemplified in which the liquid crystal mixture containing a polymerizable mesogen (a), a polymerizable chiral agent (b) and a photopolymerization initiator (c) is coated on an alignment substrate and the coat is polymerized with ultraviolet in an inert gas atmosphere (JP-A No. 2003-4406).

[0158] Description will be given of a polymerizable mesogen compound (a) and a polymerizable chiral agent (b) and the like, which form a cholesteric liquid crystal layer below, while the materials can be used in not only a cholesteric liquid crystal layer in which a pitch length varies continuously in the thickness direction but also cholesteric liquid crystal layers used to form a laminate.

[0159] A polymerizable mesogen compound (a), when being used, preferably has at least one polymerizable functional group and in addition, a mesogen group including a ring unit and others. As polymerizable functional groups, exemplified are an acryloyl group, a methacryloyl group, an epoxy group, a vinyl ether group and others, among which preferable are an acryloyl group and a methacryloyl group.

With a polymerizable mesogen compound (a) having two or more polymerizable functional groups employed, a crosslinked structure is introduced into a cholesteric liquid film to thereby enable durability thereof to be enhanced, as well. Examples of the ring unit constituting a mesogen group include: a biphenyl-based ring unit, a phenylbenzoate-based ring unit, a phenylcyclohexane-based ring unit, an azoxybenzene-based ring unit, an azomethine-based ring unit, an azobenzene-based ring unit, a phenylpyrimidine-based ring unit, a diphenylacetylene-based ring unit, a diphenylbenzoate-based ring unit, a bicyclohexane-based ring unit, a cyclohexylbenzene-based ring unit, a terphenyl-based ring unit and others. Note that an end of each of the ring units may have any of substituents such as a cyano group, an alkyl group, an alkoxy group, a halogen group. A mesogen group described above may bond with a spacer portion imparting bendability. As spacer portions, exemplified are a polymethylene chain, a polyoxymethylene chain and others. The number of repeated structural units constituting a spacer portion is properly determined according to a chemical structure of a mesogen moiety, wherein the number of repetition units in a polymethylene chain ranges from 0 to 20 and preferably from 2 to 12 and the number of repetition units in a polyoxymethylene chain ranges from 0 to 10 and preferably 1 to 3.

[0160] Molar absorption coefficients of the polymerizable mesogen compound (a) are preferably in the range of from 0.1 to 500 $\text{dm}^3 \text{mol}^{-1} \text{cm}^{-1}$ at 365 nm, in the range of from 10 to 30,000 $\text{dm}^3 \text{mol}^{-1} \text{cm}^{-1}$ at 334 nm, and in the range of from 1,000 to 100,000 $\text{dm}^3 \text{mol}^{-1} \text{cm}^{-1}$ at 314 nm. A polymerizable mesogen compound (a) with the molar absorption coefficients has an ultraviolet absorbing function. Molar absorption coefficients of a polymerizable mesogen compound (a) are more preferably in the range of from 0.1 to 50 $\text{dm}^3 \text{mol}^{-1} \text{cm}^{-1}$ at 365 nm, in the range of from 50 to 10,000 $\text{dm}^3 \text{mol}^{-1} \text{cm}^{-1}$ at 334 nm, and in the range of from 10,000 to 50,000 $\text{dm}^3 \text{mol}^{-1} \text{cm}^{-1}$ at 314 nm. Molar absorption coefficients of a polymerizable mesogen compound (a) are further more preferably in the range of from 0.1 to 10 $\text{dm}^3 \text{mol}^{-1} \text{cm}^{-1}$ at 365 nm, in the range of from 1,000 to 4,000 $\text{dm}^3 \text{mol}^{-1} \text{cm}^{-1}$ at 334 nm, and in the range of from 30,000 to 40,000 $\text{dm}^3 \text{mol}^{-1} \text{cm}^{-1}$ at 314 nm. If the molar absorption coefficients are less than 0.1 $\text{dm}^3 \text{mol}^{-1} \text{cm}^{-1}$ at 365 nm, 10 $\text{dm}^3 \text{mol}^{-1} \text{cm}^{-1}$ at 334 nm, and 1,000 $\text{dm}^3 \text{mol}^{-1} \text{cm}^{-1}$ at 314 nm, a sufficient difference in polymerization rate is realized, which makes it difficult to realize a broad band. On the other hand, if the molar absorption coefficients are larger than 500 $\text{dm}^3 \text{mol}^{-1} \text{cm}^{-1}$ at 365 nm, 30,000 $\text{dm}^3 \text{mol}^{-1} \text{cm}^{-1}$ at 334 nm, and 100,000 $\text{dm}^3 \text{mol}^{-1} \text{cm}^{-1}$ at 314 nm, polymerization may not advance perfectly with the result of no completion of curing. Note that molar absorption coefficients are obtained by measuring spectrophotometric spectrum of each material, followed by calculation based on absorbance values obtained at 365 nm, 334 nm and 314 nm.

[0161] A polymerizable mesogen compound (a) having one polymerizable functional group is expressed, for example, by the following general formula 1:

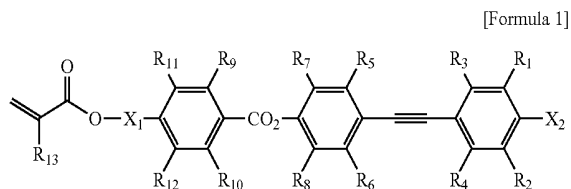

[0162] (wherein R_1 to R_{12} , which may be the same as or different from one another, indicates $-\text{F}$, $-\text{H}$, $-\text{CH}_3$, $-\text{C}_2\text{H}_5$, or $-\text{OCH}_3$, R_{13} indicates $-\text{H}$ or $-\text{CH}_3$, X_1 indicates a general formula (2) of $-(\text{CH}_2\text{CH}_2\text{O})_a-$, $(\text{CH}_2)_b-$, $(\text{O})_c-$ and X_2 indicates $-\text{CN}$ or $-\text{F}$, providing that a in the general formula (2) is an integer from 0 to 3, b therein is an integer from 0 to 12 and c therein is 0 or 1, wherein when $a=1$ to 3, $b=0$ and $c=0$ while when $a=0$, $b=1$ to 12 and $c=0$ to 1.)

[0163] As a polymerizable chiral agent (b), exemplified is LC756 manufactured by BASF Corp.

[0164] A mixing amount of a polymerizable chiral agent (b) is preferably in the range of from 1 to 20 parts by wt and more preferably in the range of from 2 to 5 parts by wt relative to 100 parts by wt of a total amount of a polymerizable mesogen compound (a) and the polymerizable chiral agent (b). A helical twist power (HTP) is controlled by a ratio of a polymerizable mesogen compound (a) and a polymerizable chiral agent (b). By adjusting the proportion within the range, a reflection band can be selected so that a reflectance spectrum of an obtained cholesteric liquid crystal film can cover a long wavelength band.

[0165] A liquid crystal mixture usually contains a photopolymerization initiators (c). As the photopolymerization initiators (c), exemplified are IRGACURE 184, IRGACURE 907, IRGACURE 369, IRGACURE 651 and others manufactured by Chiba Specialty Chemicals. A mixing amount of a photopolymerization initiator is preferably in the range of from 0.01 to 10 parts by wt and more preferably in the range of from 0.05 to 5 parts by wt relative to 100 parts by wt of a total amount of a polymerizable mesogen compound (a) and a polymerizable chiral agent (b).

[0166] A polymerizable ultraviolet absorbent (d) can be any of compounds having at least one polymerizable functional group and an ultraviolet absorbing function without a specific limitation. Concrete examples of such a polymerizable ultraviolet absorbent (d) include: for example, RUVA-93 manufactured by OTSUKA Chemical Co., Ltd and UVA935LH manufactured by BASF Ltd. and the like. A mixing amount of a polymerizable ultraviolet absorbent (d) is preferably in the range of from 0.01 to 10 parts by wt and more preferably in the range of from 2 to 5 parts by wt relative to 100 parts by wt of a total amount of a polymerizable mesogen compound (a) and a polymerizable chiral agent (b).

[0167] In order to broaden a band width of an obtained cholesteric liquid crystal film, an ultraviolet absorbent is mixed to thereby increase a difference in ultraviolet expo-

sure intensity in the thickness direction. Besides, a photo-reaction initiator with a large molar absorption coefficient is employed to the mixture thereby enable a similar effect to be obtained.

[0168] The mixture can be used as a solution. Examples of solvents each of which are preferably used in preparation of the solution, usually includes: halogenated hydrocarbons such as chloroform, dichloromethane, dichloroethane, tetrachloroethane, trichloroethylene, tetrachloroethylene, chlorobenzene and the like; phenols such as phenol, parachlorophenol and the like; aromatic hydrocarbons such as benzene, toluene, xylene, methoxybenzene, 1,2-dimethoxybenzene and the like; in addition thereto acetone, methyl ethyl ketone, ethyl acetate, tert-butyl alcohol, glycerin, ethylene glycol, triethylene glycol, ethyleneglycol monomethyl ether, diethyleneglycol dimethyl ether, ethyl cellosolve, butyl cellosolve, 2-pyrrolidone, N-methyl-2-pyrrolidone, pyridine, triethylamine, tetrahydrofuran, dimethylformamide, dimethylacetamide, dimethyl sulfoxide, acetonitrile, butyronitrile, carbon disulfide, cyclopentanone, cyclohexanone, and the like. No specific limitation is imposed on a solvent to be used and preferable are methyl ethyl ketone, cyclohexanone, cyclopentanone and the like. Since a concentration in a solution is dependent on a dissolubility of a thermotropic liquid crystal compound and a film thickness of a cholesteric liquid crystal film, which is a final object, the concentration cannot be definitely determined, but is generally preferably on the order in the range of from 3 to 50 wt %.

[0169] Note that in a case of manufacture of a cholesteric liquid crystal layer in which a pitch length varies continuously in the thickness direction as well, the alignment substrates exemplified above can be used. A similar aligning method can be adopted.

($\frac{1}{2}$ Wavelength Plate (B))

[0170] Examples of the $\frac{1}{2}$ wavelength plate (B) include: uniaxially stretched resin films or biaxially stretched resin films to thereby improve a viewing angle characteristic of films of resins such as polyethylene naphthalate, polyethylene terephthalate, polycarbonate, norbornene resin represented by Arton manufactured by JSR Corporation, polyvinyl alcohol, polystyrene, polymethyl methacrylate, polypropylene, other polyolefins, polyarylate, polyamide and the like; or a film obtained by fixing a nematic alignment state of a rod-like liquid crystal.

[0171] A $\frac{1}{2}$ wavelength plate (B) is preferably a broad band wavelength plate having a retardation characteristic working as an almost $\frac{1}{2}$ wavelength plate in the visible light band in order to make uniform optical characteristic of colors and suppress coloration. This is because if a change in retardation value is too large between wavelengths, a polarization characteristic for each wavelength is different from that of another wavelength to thereby affect shielding performances of wavelengths differently, leading to unpreferable visual recognition due to coloration. Such a $\frac{1}{2}$ wavelength plate (B) preferably has a front retardation values, which is expressed by $(n_x - n_y) \times d$, in the range of a $\frac{1}{2}$ wavelength $\pm 10\%$ at wavelengths in the light source wavelength band (ranging from 420 to 650 nm), where a direction in which an in-plane refractive index is maximized is defined as X axis and a direction perpendicular to the X axis is defined as Y axis, where refractive indices in each axis

directions are defined as n_x and n_y , respectively, and a thickness is defined as d (nm). A change of retardation value in the light source wavelength band is preferably small and desirably in the range of $\pm 7\%$ of $\frac{1}{2}$ wavelength and more desirably in the range of $\pm 5\%$ of $\frac{1}{2}$ wavelength.

[0172] Such a $\frac{1}{2}$ wavelength plate (B) can impart a retardation corresponding to a $\frac{1}{2}$ wavelength regardless of a wavelength of incident light by control of a wavelength dispersion characteristic through adoption of a laminate with axes different from one another composed of different kinds of retardation plates or molecular design.

[0173] Though a functioning wavelength band width is preferably wider, a characteristic of a $\frac{1}{2}$ wavelength plate (B) desirably works in the range of from about 420 nm to about 650 nm since in a case of a cold cathode tube, emission central wavelengths of the light source are located at 435 nm for blue, at 545 nm for green and at 610 nm for red and respective bright-lines have some level of half value widths for emission. A material of a retardation plate having such a characteristic is typically polyvinyl alcohol and materials molecular designed for an optical includes: Arton manufactured by JSR Corporation, norbornene films represented by ZENOR manufactured by Nippon Zeon Co., Ltd. and a PURE-ACE WR manufactured by TEIJIN CHEMICALS LTD and the like.

[0174] A $\frac{1}{2}$ wavelength plate (B) desirably works as a $\frac{1}{2}$ wavelength plate for an obliquely incident light. Since an optical path length of a $\frac{1}{2}$ wavelength plate increases for an obliquely incident light, a retardation value varies to thereby generally create a phenomenon that a retardation is changed away from a value requested primarily. In order to prevent it from occurring, a retardation in the thickness direction of a $\frac{1}{2}$ wavelength plate (B) is controlled to thereby preferably use a $\frac{1}{2}$ wavelength plate in which a change in retardation due to an angular change is reduced. Thereby, a retardation equal to that for normally incident light can be imparted to an obliquely incident light.

[0175] A control coefficient for a retardation in the thickness direction is generally defined with an N_z coefficient. An N_z coefficient is expressed by $N_z = (n_x - n_z) / (n_x - n_y)$, where a direction in which an in-plane refractive index is maximized is defined as X axis, a direction perpendicular to the X axis is defined as Y axis and a thickness direction of the film is defined as Z axis, where refractive indices in each axis directions are defined as n_x , n_y and n_z . In order to impart a retardation value equal to that of normally incident light to obliquely incident light, it is preferable to establish a relation $-2.5 < N_z \leq 1$. It is more preferable to establish a relation $-2 < N_z \leq 0.5$. A retardation plate in which such a control in the thickness direction is applied is typically, as an example, an NRZ film manufactured by NITTO DENKO CORPORATION. Note that secondary transmission in an oblique direction cannot be prevented by a means of a method as shown in US No. 2003/63236 A. This is because revelation of a retardation in an oblique direction is not compatible with suppression of increase in retardation in an oblique direction. An advantage of the invention resides in the fact.

[0176] A $\frac{1}{2}$ wavelength plate (B) may be constituted of a single retardation plate or a laminate of two or more retardation plates can be laminated so as to obtain a desired retardation. A thickness of a $\frac{1}{2}$ wavelength plate (B) is preferably in the range of from 0.5 to 200 μm and especially preferably in the range of from 1 to 100 μm .

(Retardation Layer (C))

[0177] A retardation layer (C) gives almost zero retardation in the front direction and gives retardation to incident light in a direction inclined from the normal direction. Since a front retardation serves to sustain a polarization state of incident light the normal direction, it is desirably a $\lambda/10$ or less.

[0178] The retardation layer (C) gives retardation to incident light in a direction inclined from the normal direction. An oblique direction of incident light in the direction is properly determined by an angle at which the light is totally reflected in order to effectively cause polarization conversion of the incident light. For example, in order to totally reflect incident light at an angle of the order of 60 degrees relative to the normal direction, a retardation is determined to be on the about $\lambda/4$ when the retardation is measured at 60 degrees. A C-plate, which is used as a retardation layer (C), and a $\frac{1}{2}$ wavelength plate (B) are combined and a selective reflection wavelength band of the C-plate is set to the side of a wavelength longer than that of the visible light band; thereby enabling a retardation of the C-plate, which is even on the about $\frac{1}{32}$ wavelength when being measured in a direction inclined from the normal direction by 30 degrees, to ensure a necessary characteristic. This is a phenomenon specific to a case of a combination of the polarizing element (A), the $\frac{1}{2}$ wavelength plate (B), the retardation layer (C) having a selective reflection wavelength, the $\frac{1}{4}$ wavelength plate (D) and the linearly polarized light reflection polarizer (E). A C-plate having a selective reflection wavelength even on the short wavelength side can achieve a desirable performance in a similar way to that as described above except for that a necessary retardation is larger.

[0179] In order to, giving consideration to a retardation of a circularly polarized light reflective polarizer (a) as described above, correct the retardation, a retardation layer (C) gives retardation to incident light in a direction inclined from the normal direction. A retardation given from retardation layer (C) to incident light in an oblique direction is properly adjusted so as to be adapted for the polarizing element (A).

[0180] Any of materials can be used in the retardation layers (C) without a specific limitation as far as it has an optical characteristic as described above. Exemplified are: a layer having a fixed planar alignment state of a cholesteric liquid crystal having a selective reflection wavelength in a region outside a visible light region (ranging from 380 nm to 780 nm); a layer having a fixed homeotropic alignment state of a rod-like liquid crystal; a layer using columnar alignment or nematic alignment of a discotic liquid crystal; a layer in which a negative uniaxial crystal is aligned in a plane; a layer made of a biaxially aligned polymer film; and others. Examples thereof also include films produced with at least one polymer selected from the group consisting of polyamide, polyimide, polyester, poly(etherketone), poly(amide-imide), and poly(ester-imide). These films can be obtained through a process including the steps of dissolving the polymer in a solvent, applying the resulting solution to a substrate, and drying the solution. The substrate is preferably made of a material whose rate of change in dimension is at most 1% in the drying process. Examples thereof also include layers of a nematic or discotic liquid crystal whose alignment direction is fixed so as to continuously vary in the thickness direction.

[0181] A C-plate having a fixed planar alignment state of a cholesteric liquid crystal having a selective reflection wavelength in a region outside the visible light region (ranging from 380 nm to 780 nm) is desirable to have no coloring abnormality in the visible light region with respect to a selective reflection wavelength of a cholesteric liquid crystal. Hence, a necessity arises for a selective reflection light not to be in the visible region. Selective reflection is specially determined by a cholesteric chiral pitch and a refractive index of a liquid crystal. A value of a central wavelength in selective reflection may be in the near infrared region, whereas it is more desirably in an ultraviolet region of 350 nm or less because of an influence of optical rotation exerted or occurrence of a slightly complex phenomenon. Formation of a cholesteric liquid crystal layer is performed in a similar way to that in formation of a cholesteric liquid crystal layer in the reflection polarizer described above.

[0182] A C-plate having a fixed homeotropic alignment state is made of a liquid crystalline thermoplastic resin showing a nematic liquid crystallinity at a high temperature; a polymerized liquid crystal obtained by polymerizing a liquid crystal monomer and an alignment agent, when required, under illumination with ionizing radiation such as an electron beam, ultraviolet or the like, or with heating; or a mixture thereof. While a liquid crystallinity may be either lyotropic or thermotropic, a thermotropic liquid crystal is desirable from the view point of ease of control and formability of monodomain. A homeotropic orientation is obtained for example in a procedure in which a birefringent material described above is coated on a film made of a vertically aligned film (such as a film of a long chain alkylsilane) and a liquid crystal state is produced and fixed in the film.

[0183] As a C-plate using a discotic liquid crystal, there is available a plate obtained by producing and fixing a nematic phase or a columnar phase in a discotic liquid crystal material having an optically negative uniaxiality such as a phthalocyanines or a triphenylene compounds each having an in-plane spread molecule as a liquid crystal material. Inorganic layered compounds each with a negative uniaxiality are detailed in a publication of JP-A No. 6-82777 and others.

[0184] A C-plate using a biaxial alignment of a polymer film can be obtained by one of the following methods, in which a polymer film having positive refractive index anisotropy is biaxially stretched in a good balance; in which a thermoplastic resin is pressed; and in which a C-plate is cut off from a parallel aligned crystal.

[0185] Each retardation layer (C) may be made of a single piece of retardation plate or may be made of two or more pieces of retardation plates for the desired retardation.

($\frac{1}{4}$ wavelength plate (D))

[0186] A $\frac{1}{4}$ wavelength plate (D) can be one obtained by controlling a retardation using a material similar to that of the $\frac{1}{2}$ wavelength plate (B). The $\frac{1}{4}$ wavelength plate (D) is also preferably a broad band wavelength plate working as an almost $\frac{1}{4}$ wavelength plate all over the visible light band. A front retardation value at each wavelength in a wavelength band of a light source ranging from 420 to 650 nm is desirably in the range of $\pm 10\%$ of a $\frac{1}{4}$ wavelength. The front

retardation value is desirably in the range of $\pm 7\%$ of a $\frac{1}{4}$ wavelength and more desirably in the range of $\pm 5\%$ or less of a $\frac{1}{4}$ wavelength. Moreover, an Nz value is preferably $-2.5 < Nz \leq 1$ and more preferably $-2 < Nz \leq 0.5$.

[0187] A $\frac{1}{4}$ wavelength plate (D) may be constituted of a single retardation plate and can also be a two or more layer retardation plate laminated so as to give a desired retardation. A thickness of a $\frac{1}{4}$ wavelength plate (D) is usually in the range of from 0.5 to 200 μm and especially preferably in the range of from 1 to 100 μm .

(Linearly Polarized Light Reflection Polarizer (E))

[0188] Examples of the linearly polarized light reflection polarizer (E) include: a grid type polarizer; a multilayer thin film laminate with two or more layers made of two or more kinds of materials having a difference between refractive indices; evaporated multilayer thin film having different refractive indexes used in a beam splitter or the like; a multi-birefringence layer thin film laminate with two or more layers made of two or more kinds of materials each having a birefringence; a stretched resin laminate with two or more layers containing two or more kinds of resins each having a birefringence; a polarizer separating linearly polarized light by reflecting/transmitting linearly polarized light in the axis directions perpendicular to each other; and others.

[0189] A uniaxially stretched multilayer laminate can be used that is obtained by uniaxially stretching a multilayer laminate obtained by alternately laminating materials generating a retardation by stretching represented by polyethylene naphthalate, polyethylene terephthalate and polycarbonate; and resins each generating a low retardation, such as an acrylic resin represented by polymethacrylate; and a norbornene resin and others represented by ARTON manufactured by JSR Corp. As concrete examples of the linearly polarized light reflection polarizer (E), exemplified are DBEF (Dual Brightness Enhancement film) manufactured by 3M Corp., PCF manufactured by NITTO DENKO Corp., or the like.

[0190] A selective reflection wavelength width of a linearly polarized light reflection polarizer (E) is, similarly to a polarizing element (A), desirably 200 nm or more, more desirably 300 nm or more and further more desirably 400 nm or more. In order to cover the visible light band, the width preferably covers the range of from 400 to 600 nm, to be concrete. It is desirable to extend a selective reflection wavelength band mainly to the longer wavelength side, in order to cover the visible light band regardless of an incidence angle, because of Shifting of a selective reflection wavelength band to the shorter wavelength side according to an incidence angle, to which, however, no limitation is imposed.

[0191] In a polarizing element (A) and a linearly polarized light reflection polarizer (E), selective reflection wavelength bands contain at least 550 nm and are overlapped one on the other by desirably 100 nm or more, more desirably 200 nm or more and further desirably 300 nm or more.

(Lamination of Layers)

[0192] An optical element of the present invention is not only disposed in an optical path in a simple manner, but can also be used by adhering. This is because since the optical

element controls transmittance with a polarization characteristic thereof without using a surface profile, no air interface is required.

[0193] Lamination of each of the layers may be realized only by being laminated on a preceding layer, while it is preferable to laminate the layers with an adhesive agent or a pressure-sensitive adhesive agent from the viewpoint of workability and light utilization efficiency. In that case, it is desirable from the viewpoint of suppressed surface reflection that an adhesive agent or a pressure-sensitive adhesive agent is transparent and does not have absorption in the visible light region, and have refractive indexes closest possible to refractive indexes of the layers. Preferably used from the view point are an acrylic pressure-sensitive adhesive agent and the like. The following methods can be adopted: one method in which each of the layers forms monodomain with the help of an alignment film separately from the others and sequentially laminated by transfer the layers onto a light transparent base material; and the other in which each of the layers is sequentially formed directly on a preceding layer while forming an alignment film or the like for alignment in a proper manner.

[0194] It is possible to further add particles for adjusting diffusibility, when required, to thereby impart isotropic scatterability, and to properly add an ultraviolet absorbent, an antioxidant, and a surfactant for a purpose to impartation of a leveling property in film formation, in each of the layers and (pressure-sensitive) adhesive layers.

(Light Condensation Backlight System)

[0195] A diffusion reflector plate is preferably disposed on a light source (on the other side of the light source from the side on which a liquid crystal cell is disposed). A main component of light reflected on a light collimating film is an obliquely incident component and regularly reflected on the light collimating film and returned in the backlight direction. Herein, in a case where a regular reflectance of a reflecting plate on the rear side is high, a reflection angle is kept as is and the reflected light cannot be emitted in the front direction only to end up with lost light. Therefore, a diffusion reflector plate is desirably disposed in order not to hold a reflection angle of reflected-back light as is and to thereby increase a scattering reflection component in the front direction.

[0196] Light condensation characteristic according to the present invention can controllably condense light in the front direction even in a case of a diffusion surface light source such as a direct under type backlight or an inorganic/organic EL element.

[0197] It is desired to insert a proper diffusing plate (DF) between an optical element (X) of the present invention and a backlight source (L). This is because light passes through obliquely, reflected light is scattered in the vicinity of a backlight guide and part of the reflected light is scattered in the vertically incident direction to thereby enhance a light recycling efficiency. As diffusing plates, exemplified are a plate having a surface unevenness shape and a plate made of a resin in which fine particles different in refractive index embedded. A diffusing plate may be inserted between the optical element (X) and a backlight or adhered to the optical element (X).

[0198] In a case where a liquid crystal cell (LC) to which an optical element (X) is adhered is disposed in the prox-

imity of the backlight, while there arises a chance to generate Newton's rings in a clearance between a film surface and the backlight, generation of Newton's rings can be suppressed by disposing a diffusing plate having a surface unevenness on a surface of a light guide plate of the optical element (X) in the present invention. A layer that has both of a surface unevenness and a light diffusing structure may be formed on a surface itself of an optical element (X) in this invention.

(Liquid Crystal Display)

[0199] The optical element (X) is preferably applied to a liquid crystal display in which polarizing plates (P) are disposed on both sides of a liquid crystal cell (LC), and the optical element (X) is disposed on the polarizing plate (P) side on the light source side surface of the liquid crystal cell. FIG. 14 is a state where a polarizing plate (P) is laminated on a linearly polarized light reflection polarizer (E). The optical element (X) is arranged so to be the polarizing element (A) to the light source side.

[0200] In FIGS. 16 to 19, there are exemplified liquid crystal displays. In FIGS. 16 to 19, the optical element (Y) is exemplified used. There are shown a reflecting plate (RF) together with a light source (L). FIG. 16 shows a case where a direct under type backlight (L) is employed as a light source (L). FIG. 17 shows a case where a sidelight type light source (L) is employed as a light guide plate (S). FIG. 18 shows a case where a surface light source (L) is employed. FIG. 19 shows a case where a prism sheet (Z) is employed.

[0201] By laminating a diffusion plate having neither backscattering nor polarization cancellation on a viewer side of the liquid crystal cell of a liquid crystal display combined with the light collimating backlight system, light having a good display characteristic in the vicinity of the front is diffused to obtain a good and uniform display characteristic in all the viewing angle range, thereby enabling a viewing angle magnification to be realized.

[0202] A viewing angle magnifying layer used here is a diffusion plate having substantially no backscattering. A diffusion plate can be provided with a diffusion pressure-sensitive material. An arrangement place thereof can be used above or below a polarizing plate on the viewer side of the liquid crystal display. In order to prevent reduction in contrast due to an influence such as bleeding of pixels or a slightly remaining backscattering, the diffusion plate is desirably provided in a layer at a position closest possible to a cell such as between a polarizing plate and a liquid crystal cell. In this case, it is desirable to use a film that does not substantially cancel polarization. A fine particle distribution type diffusion plate is preferably used, which is disclosed in, for example, the publications of JP-A No. 2000-347006 and JP-A No. 2000-347007.

[0203] In a case where a viewing angle magnifying layer is disposed outside of a polarizing plate, a viewing angle compensating retardation plate may not be used especially if a TN liquid crystal cell is used since collimated lights are transmitted through a liquid crystal cell and through the polarizing plate. If an STN liquid crystal cell is used in the case, it has only to use a retardation film that is well compensated with respect to a front characteristic. Since, in this case, a viewing angle magnifying layer as a surface exposed to air, a type having a refractive effect due to a surface profile can also be employed.

[0204] On the other hand, in a case where a viewing angle magnifying film is inserted between a polarizing plate and a liquid crystal cell, light is diffused light at the stage where light is transmitted through the polarizing plate. If a TN liquid crystal is used, a necessity arises for compensating a viewing angle characteristic of the polarizer itself. In this case, it is preferable to insert a retardation plate to compensate a viewing angle characteristic of a polarizing plate between the polarizing plate and the viewing angle magnifying layer. If an STN liquid crystal is used, it is preferable to insert a retardation plate to compensate a viewing angle characteristic of the polarizer in addition to a front retardation compensation for the STN liquid crystal.

[0205] In a case of a viewing angle magnifying film having a regular structure in the interior thereof such as a microlens array or a hologram film, both conventionally having been available, interference has occurred with a fine structure such as a microlens array, a prism array, a louver, a micromirror array or the like that is included in a black matrix of a liquid crystal display or a collimation system of a conventional backlight to thereby cause a moiré pattern with ease. Since in a collimating film in this invention, a regular structure is not visually recognized in a plane thereof and emitted light has no regularity modulation, no necessity arises for consideration of matching with a viewing angle magnifying layer or an arrangement sequence. Therefore, a viewing angle magnifying layer has a lot of options since no specific limitation is imposed thereon, if neither interference nor a moiré pattern occurs with a pixel black matrix of a liquid crystal display.

[0206] In this invention, as viewing angle magnifying layers, preferably used are a light scattering plate, having no substantial backscattering and not canceling polarization, which is described in any of the publications of JP-A Nos. 2000-347006 and 2000-347007 and which has a haze in the range of 80% to 90%. Any of layers each of which has a regular structure in the interior thereof such as a hologram sheet, a microprism array, a microlens array or the like can be used, if neither interference nor a moiré pattern occurs with a pixel black matrix of a liquid crystal display.

(Other Materials)

[0207] Note that various other kinds of optical layers are properly employed according a common method to thereby, manufacture a liquid crystal display.

[0208] Commonly used is a polarizing plate having a protective film on one side or both sides of a polarizer.

[0209] A polarizer is not limited especially but various kinds of polarizer may be used. As a polarizer, for example, a film that is uniaxially stretched after having dichromatic substances, such as iodine and dichromatic dye, absorbed to hydrophilic high molecular weight polymer films, such as polyvinyl alcohol type film, partially formalized polyvinyl alcohol type film, and ethylene-vinyl acetate copolymer type partially saponified film; poly-ene type orientation films, such as dehydrated polyvinyl alcohol and dehydrochlorinated polyvinyl chloride, etc. may be mentioned. In these, a polyvinyl alcohol type film on which dichromatic materials such as iodine is absorbed and oriented after stretched is suitably used. Although thickness of polarizer is not especially limited, the thickness of about 5 to 80 μm is commonly adopted.

[0210] A polarizer that is uniaxially stretched after a polyvinyl alcohol type film dyed with iodine is obtained by stretching a polyvinyl alcohol film by 3 to 7 times the original length, after dipped and dyed in aqueous solution of iodine. If needed the film may also be dipped in aqueous solutions, such as boric acid and potassium iodide, which may include zinc sulfate, zinc chloride. Furthermore, before dyeing, the polyvinyl alcohol type film may be dipped in water and rinsed if needed. By rinsing polyvinyl alcohol type film with water, effect of preventing un-uniformity, such as unevenness of dyeing, is expected by making polyvinyl alcohol type film swelled in addition that also soils and blocking inhibitors on the polyvinyl alcohol type film surface may be washed off. Stretching may be applied after dyed with iodine or may be applied concurrently, or conversely dyeing with iodine may be applied after stretching. Stretching is applicable in aqueous solutions, such as boric acid and potassium iodide, and in water bath.

[0211] As the transparent protective film prepared on one side or both sides of the polarizer, materials is excellent in transparency, mechanical strength, heat stability, water shielding property, isotropy, etc. may be preferably used. As materials of the above-mentioned transparent protective film, for example, polyester type polymers, such as polyethylene terephthalate and polyethylenephthalate; cellulose type polymers, such as diacetyl cellulose and triacetyl cellulose; acrylics type polymer, such as poly methylmethacrylate; styrene type polymers, such as polystyrene and acrylonitrile-styrene copolymer (AS resin); polycarbonate type polymer may be mentioned. Besides, as examples of the polymer forming a protective film, polyolefin type polymers, such as polyethylene, polypropylene, polyolefin that has cyclo-type or norbornene structure, ethylene-propylene copolymer; vinyl chloride type polymer; amide type polymers, such as nylon and aromatic polyamide; imide type polymers; sulfone type polymers; polyether sulfone type polymers; polyether-ether ketone type polymers; poly phenylene sulfide type polymers; vinyl alcohol type polymer; vinylidene chloride type polymers; vinyl butyral type polymers; arylate type polymers; polyoxymethylene type polymers; epoxy type polymers; or blend polymers of the above-mentioned polymers may be mentioned as a. Films made of heat curing type or ultraviolet ray curing type resins, such as acryl based, urethane based, acryl urethane based, epoxy based, and silicone based, etc. may be mentioned as materials of the above-mentioned transparent protective film.

[0212] Moreover, as is described in Japanese Patent Laid-Open Publication No. 2001-343529 (WO 01/37007), polymer films, for example, resin compositions including (A) thermoplastic resins having substituted and/or non-substituted imido group is in side chain, and (B) thermoplastic resins having substituted and/or non-substituted phenyl and nitrile group in side chain may be mentioned. As an illustrative example, a film may be mentioned that is made of a resin composition including alternating copolymer comprising iso-butylene and N-methyl maleimide, and acrylonitrile-styrene copolymer. A film comprising mixture extruded article of resin compositions etc. may be used.

[0213] In general, a thickness of the protection film, which can be determined arbitrarily, is 500 μm or less, preferably 1 to 300 μm , and especially preferably 5 to 200 μm in viewpoint of strength, work handling and thin layer

[0214] Moreover, it is preferable that the protective film may have as little coloring as possible. Accordingly, a protective film having a retardation value in a film thickness direction represented by $R_{th} = [(n_x + n_y)/2 - n_z] \times d$ of -90 nm to $+75 \text{ nm}$ (where, n_x and n_y represent principal indices of refraction in a film plane, n_z represents refractive index in a film thickness direction, and d represents a film thickness) may be preferably used. Thus, coloring (optical coloring) of polarizing plate resulting from a protective film may mostly be cancelled using a protective film having a retardation value (R_{th}) of -90 nm to $+75 \text{ nm}$ in a thickness direction. The retardation value (R_{th}) in a thickness direction is preferably -80 nm to $+60 \text{ nm}$, and especially preferably -70 nm to $+45 \text{ nm}$.

[0215] As a protective film, if polarization property and durability are taken into consideration, cellulose based polymer, such as triacetyl cellulose, is preferable, and especially triacetyl cellulose film is suitable. In addition, when the protective films are provided on both sides of the polarizer, the protective films comprising same polymer material may be used on both of a front side and a back side, and the protective films comprising different polymer materials etc. may be used. Adhesives are used for adhesion processing of the above described polarizer and the protective film. As adhesives, isocyanate derived adhesives, polyvinyl alcohol derived adhesives, gelatin derived adhesives, vinyl polymers derived latex type, aqueous polyurethane based adhesives, aqueous polyesters derived adhesives, etc. may be mentioned.

[0216] A hard coat layer may be prepared, or antireflection processing, processing aiming at sticking prevention, diffusion or anti glare may be performed onto the face on which the polarizing film of the above described transparent protective film has not been adhered.

[0217] A hard coat processing is applied for the purpose of protecting the surface of the polarizing plate from damage, and this hard coat film may be formed by a method in which, for example, a curable coated film with excellent hardness, slide property etc. is added on the surface of the transparent protective film using suitable ultraviolet curable type resins, such as acrylic type and silicone type resins. Antireflection processing is applied for the purpose of antireflection of outdoor daylight on the surface of a polarizing plate and it may be prepared by forming an antireflection film according to the conventional method etc. Besides, a sticking prevention processing is applied for the purpose of adherence prevention with adjoining layer.

[0218] In addition, an anti glare processing is applied in order to prevent a disadvantage that outdoor daylight reflects on the surface of a polarizing plate to disturb visual recognition of transmitting light through the polarizing plate, and the processing may be applied, for example, by giving a fine concavo-convex structure to a surface of the protective film using, for example, a suitable method, such as rough surfacing treatment method by sandblasting or embossing and a method of combining transparent fine particle. As a fine particle combined in order to form a fine concavo-convex structure on the above-mentioned surface, transparent fine particles whose average particle size is 0.5 to 50 μm , for example, such as inorganic type fine particles that may have conductivity comprising silica, alumina, titania, zirconia, tin oxides, indium oxides, cadmium oxides, antimony oxides,

etc., and organic type fine particles comprising cross-linked of non-cross-linked polymers may be used. When forming fine concavo-convex structure on the surface, the amount of fine particle used is usually about 2 to 50 wt parts to the transparent resin 100 wt parts that forms the fine concavo-convex structure on the surface, and preferably 5 to 25 wt parts. An anti glare layer may serve as a diffusion layer (viewing angle expanding function etc.) for diffusing transmitting light through the polarizing plate and expanding a viewing angle etc.

[0219] In addition, the above-mentioned antireflection layer, sticking prevention layer, diffusion layer, anti glare layer, etc. may be built in the protective film itself, and also they may be prepared as an optical layer different from the transparent protective film.

[0220] A retardation plate is laminated on a polarizing plate as a viewing angle compensating film and used as a wide viewing angle polarizing plate. A viewing angle compensating film is a film for magnifying a viewing angle so as to enable an image to be viewed with relatively sharpness even in a case where a screen image of a liquid crystal display is viewed not in a direction normal to the screen but in a slightly oblique direction relative to the screen. As the retardation plates, employed are a $\frac{1}{4}$ wavelength plate and a $\frac{1}{2}$ wavelength plate that are proper and meet the purpose of use. These materials include the same materials of the $\frac{1}{2}$ wavelength plate (B), and are employed to be controlled retardation.

[0221] As such viewing angle compensating retardation plates, there are available, in addition thereto, a film having a birefringence obtained by a biaxially stretching treatment, a stretching treatment in two directions perpendicular to each other or the like and a biaxially stretched film such as an inclined alignment film. As inclined alignment film, for example, a film obtained using a method in which a heat shrinking film is adhered to a polymer film, and then the combined film is heated and stretched or shrunk under a condition of being influenced by a shrinking force, or a film that is oriented in oblique direction may be mentioned. The viewing angle compensation film is suitably combined for the purpose of prevention of coloring caused by change of visible angle based on retardation by liquid crystal cell etc. and of expansion of viewing angle with good visibility.

[0222] Besides, a compensation plate in which an optical anisotropy layer consisting of an alignment layer of liquid crystal polymer, especially consisting of an inclined alignment layer of discotic liquid crystal polymer is supported with triacetyl cellulose film may preferably be used from a viewpoint of attaining a wide viewing angle with good visibility.

[0223] No specific limitation is, in addition to the above described condition, imposed on optical layers laminated when being actually used and there can be used one, or two or more optical layers that have an opportunity to be used in formation of a liquid crystal display and others, such as a

reflection plate and a transfective plate. Examples thereof especially include: a reflection type polarizing plate and a transfective type polarizing plate obtained by laminating a reflection plate and a transfective plate, respectively, on an elliptic polarizing plate or a circular polarizing plate.

[0224] A reflective layer is prepared on a polarizing plate to give a reflection type polarizing plate, and this type of plate is used for a liquid crystal display in which an incident light from a view side (display side) is reflected to give a display. This type of plate does not require built-in light sources, such as a backlight, but has an advantage that a liquid crystal display may easily be made thinner. A reflection type polarizing plate may be formed using suitable methods, such as a method in which a reflective layer of metal etc. is, if required, attached to one side of a polarizing plate through a transparent protective layer etc.

[0225] As an example of a reflection type polarizing plate, a plate may be mentioned on which, if required, a reflective layer is formed using a method of attaching a foil and vapor deposition film of reflective metals, such as aluminum, to one side of a matte treated protective film. Moreover, a different type of plate with a fine concavo-convex structure on the surface obtained by mixing fine particle into the above-mentioned protective film, on which a reflective layer of concavo-convex structure is prepared, may be mentioned. The reflective layer that has the above-mentioned fine concavo-convex structure diffuses incident light by random reflection to prevent directivity and glaring appearance, and has an advantage of controlling unevenness of light and darkness etc. Moreover, the protective film containing the fine particle has an advantage that unevenness of light and darkness may be controlled more effectively, as a result that an incident light and its reflected light that is transmitted through the film are diffused. A reflective layer with fine concavo-convex structure on the surface effected by a surface fine concavo-convex structure of a protective film may be formed by a method of attaching a metal to the surface of a transparent protective layer directly using, for example, suitable methods of a vacuum evaporation method, such as a vacuum deposition method, an ion plating method, and a sputtering method, and a plating method etc.

[0226] Instead of a method in which a reflection plate is directly given to the protective film of the above-mentioned polarizing plate, a reflection plate may also be used as a reflective sheet constituted by preparing a reflective layer on the suitable film for the transparent film. In addition, since a reflective layer is usually made of metal, it is desirable that the reflective side is covered with a protective film or a polarizing plate etc. when used, from a viewpoint of preventing deterioration in reflectance by oxidation, of maintaining an initial reflectance for a long period of time and of avoiding preparation of a protective layer separately etc.

[0227] In addition, a transfective type polarizing plate may be obtained by preparing the above-mentioned reflec-

tive layer as a transfective type reflective layer, such as a half-mirror etc. that reflects and transmits light. A transfective type polarizing plate is usually prepared in the backside of a liquid crystal cell and it may form a liquid crystal display of a type in which a picture is displayed by an incident light reflected from a view side (display side) when used in a comparatively well-lighted atmosphere. And this unit displays a picture, in a comparatively dark atmosphere, using embedded type light sources, such as a back light built in backside of a transfective type polarizing plate. That is, the transfective type polarizing plate is useful to obtain of a liquid crystal display of the type that saves energy of light sources, such as a back light, in a well-lighted atmosphere, and can be used with a built-in light source if needed in a comparatively dark atmosphere etc.

[0228] Moreover, the polarizing plate may consist of multi-layered film of laminated layers of a polarizing plate and two or more of optical layers as the above-mentioned separated type polarizing plate. Therefore, a polarizing plate may be a reflection type elliptically polarizing plate or a transfective type elliptically polarizing plate, etc. in which the above-mentioned reflection type polarizing plate or a transfective type polarizing plate is combined with above described retardation plate respectively.

[0229] The elliptically polarizing plate or transfective type elliptically polarizing plate is laminated the polarizing plate or reflection type polarizing plate and the retardation plate by appropriately combination. As to the elliptically polarizing plate or the like, a (reflection type) polarizing plate and a retardation plate described above can be formed by sequentially laminating layers one at a time in a manufacturing process for a liquid crystal display, an optical film such as an elliptic polarizing plate or the like obtained by lamination in advance has an advantage of being excellent in quality stability, workability in lamination and others and enabling a production efficiency of a liquid crystal display to be improved.

[0230] A pressure-sensitive adhesive layer or an adhesive layer can also be provided in an optical element of this invention. A pressure-sensitive layer can be used for adherence to a liquid crystal cell and in addition, is used in lamination of optical layers. In adherence of the optical film, the optical axis thereof can be set at a proper arrangement angle in adaptation for a retardation characteristic as a target.

[0231] As the pressure sensitive adhesive agent or the adhesive agent is not especially limited. For example, polymers such as acrylic type polymers; silicone type polymers; polyesters, polyurethanes, polyamides, polyvinyl ethers, vinyl acetate/vinyl chloride copolymers, modified polyolefines, epoxy type; and rubber type such as fluorine type, natural rubber, synthetic rubber may be suitably selected as a base polymer. Especially, the one which is excellent in optical transparency, showing adhesion characteristics with

moderate wettability, cohesiveness and adhesive property and has outstanding weather resistance, heat resistance, etc. may be preferably used.

[0232] The pressure sensitive adhesive agent or the adhesive agent adhesive may contain cross-linking agent according to a base polymer. And the adhesive agent adhesive may contain additives, for example, such as natural or synthetic resins, adhesive resins, glass fibers, glass beads, metal powder, fillers comprising other inorganic powder etc., pigments, colorants and antioxidants. Moreover, it may be an adhesive layer that contains fine particle and shows optical diffusion nature.

[0233] An adhesive agent and a pressure-sensitive adhesive agent each are usually used as an adhesive agent solution of a base polymer or a composition thereof dissolved or dispersed in a solvent at a solid matter concentration of the order in the range of from 10 to 50 wt %. An organic solvent can be properly selected from the group consisting of toluene, ethyl acetate and others; water; or others, so as to be adapted for a kind of an adhesive agent for use.

[0234] An adhesive layer and pressure-sensitive adhesive layer may also be prepared on one side or both sides of a polarizing plate or an optical film as a layer in which pressure sensitive adhesives with different composition or different kind etc. are laminated together. Moreover, when adhesive layers are prepared on both sides, adhesive layers that have different compositions, different kinds or thickness, etc. may also be used on front side and backside of a polarizing plate or an optical film. Thickness of an adhesive layer may be suitably determined depending on a purpose of usage or adhesive strength, etc., and generally is 1 to 500 μm , preferably 5 to 200 μm , and more preferably 10 to 100 μm .

[0235] A temporary separator is attached to an exposed side of an adhesive layer to prevent contamination etc., until it is practically used. Thereby, it can be prevented that foreign matter contacts adhesive layer in usual handling. As a separator, without taking the above-mentioned thickness conditions into consideration, for example, suitable conventional sheet materials that is coated, if necessary, with release agents, such as silicone type, long chain alkyl type, fluorine type release agents, and molybdenum sulfide may be used. As a suitable sheet material, plastics films, rubber sheets, papers, cloths, no woven fabrics, nets, foamed sheets and metallic foils or laminated sheets thereof may be used.

[0236] In addition, in the present invention, ultraviolet absorbing property may be given to the above-mentioned each layer, such as a polarizer for a polarizing plate, a transparent protective film and an optical film etc. and an adhesive layer, using a method of adding UV absorbents, such as salicylic acid ester type compounds, benzophenol type compounds, benzotriazol type compounds, cyano acrylate type compounds, and nickel complex salt type compounds.

EXAMPLES

[0237] Description will be given, in a concrete manner, of the present invention using examples and comparative examples below and it should be understood that this invention is not limited by the examples in any way. Measurements are as described below.

(Reflection Wavelength Band)

[0238] A reflectance spectrum was measured with a spectrophotometer (manufactured by Otsuka Electronics Co., Ltd. with a trade name of Instant multi-photometric system MCPD-2000) and a wavelength band that includes a reflectance $\frac{1}{2}$ times the maximum reflectance was determined as a reflection wavelength, band.

(Distortion Rate)

[0239] In order to evaluate a distortion rate of a polarizing element, a transmission spectrum of a sample was measured with an Instant multi-photometer (manufactured by Otsuka Electronics Co., Ltd. with a trade name of MCPD-2000). In a case where natural light is launched onto a sample in a direction normal to the sample (so that emitting light from the front was measured) and in a case where a sample is set to a posture at an angle inclined from the normal direction by 60 degrees (60 degree emitting light was measured), states of light transmitted through the samples were measured on transmission spectra of light when a polarizing plate disposed on the emitting side was rotated 10 degrees at one time. The polarizing plate in use was a Glan-Thompson Prism polarizer (an extinction ratio of 0.00001 or less) manufactured by SIGMA KOKI CO., LTD. A distortion rate was obtained using the following formula for calculation. Distortion rate=minimum transmittance/maximum transmittance.

(Retardation)

[0240] A retardation of a wavelength plate is, where a direction in which an in-plane refractive index is maximized

is defined as X axis, a direction perpendicular to the X axis is defined as Y axis and a thickness direction of the film is designed as Z axis, and refractive indices in the axis directions are defined as n_x , n_y and n_z , the refractive indices n_x , n_y and n_z at 550 nm were measured with an automatic birefringence measuring instrument (automatic birefringence meter KOBRA21ADH, manufactured by Oji Scientific Instruments). The front retardation $(n_x - n_y) \times d$ was calculated with a thickness d (nm). Besides, an N_z coefficient was calculated.

[0241] A light source (diffusing light source) was Light Table KLV7000 manufactured by Hakuba K.K. Other measuring instruments were used for Haze measurement (with a trade name of haze meter HM150, manufactured by MURAKAMI COLOR RESEARCH LABORATORY), spectral characteristics of transmission/reflection (with a trade name of spectrophotometer U4100, manufactured by Hitachi, Ltd.), characteristics of a polarizing plate (with a trade name of DOT3, manufactured by MURAKAMI COLOR RESEARCH LABORATORY), brightness measurement (with a trade name of a brightness meter BM7, manufactured by TOPCON CORPORATION), brightness and tone angular distribution measuring instrument (with a trade name of Ez-Contrast, manufactured by ELDIM Inc.) and ultra violet irradiator (with a trade name of irradiator UVC321AM1, manufactured by Ushio Inc.).

Example 1

(Polarizing Element (A))

[0242] Six kinds of cholesteric liquid crystal polymers with selective reflection central wavelengths of 420 nm, 460 nm, 510 nm, 580 nm, 660 nm and 710 nm were prepared based on the specification of EP No. 0834754 A1.

[0243] A cholesteric polymer was manufactured with a polymerizable nematic liquid crystal monomer A expressed by the following chemical structure 2:

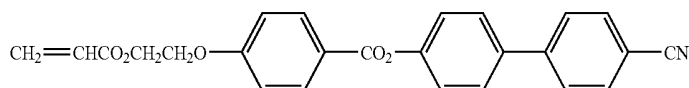

and a polymerizable chiral agent B expressed by the following chemical structure 3 in the following proportions (in wt ratios)

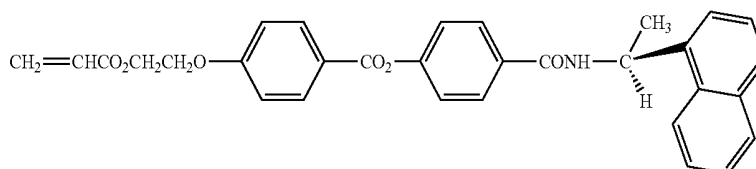

[0244] selective reflection central wavelength: monomer A/chiral agent B (mixing ratio): selective reflection wavelength band (nm)

420 nm:	8/1	430 to 460 nm
460 nm:	9.2/1	430 to 490 nm
510 nm:	10.7/1	480 to 550 nm
580 nm:	12.8/1	540 to 620 nm
660 nm:	14.7/1	620 to 810 nm
710 nm:	16/1	660 to 880 nm

[0245] The liquid crystal mixture was dissolved into tetrahydrofuran to obtain a 33% solution, thereafter, the solution was purged with nitrogen in a circumstance at 60° C., then, a reaction initiator (azobisisobutyronitrile, 0.5 wt % relative to the mixture) was added into the solution and polymerization was performed. An obtained polymer was subjected to reprecipitation separation with diethyl ether to thereby purify the polymer.

[0246] The cholesteric liquid crystal polymer was dissolved into methylene chloride to prepare a 10 wt % solution. The solution was coated on an alignment substrate to a thickness of about 1.5 μm after drying with a wire bar. A polyethylene terephthalate (PET) film with 75 μm in thickness and a polyimide alignment film was coated to a thickness of about 0.1 μm and rubbed with a layon rubbing cloth was used as an alignment substrate. The rubbed alignment film after coating was dried at 140° C. for 15 min. After the heat treatment, a liquid crystal was fixedly cooled thereon at room temperature to obtain a thin film.

[0247] Layers in colors were coated on the obtained liquid thin film one on another through steps similar to those described above and the layers were sequentially laminated from the longer wavelength side to the shorter wavelength side. Thereby, a laminate of cholesteric liquid crystal with a thickness of about 8 μm was obtained by laminating six liquid crystal layers in the order from the shorter wavelength side. The laminate of the obtained cholesteric liquid crystal was used after peeled off from the PET substrate. The obtained laminate made of the cholesteric liquid crystals had a selective reflection function in the range of from 400 nm to 880 nm. The laminate was used as a polarizing element (A1-1).

[0248] The polarizing element (A1-1) had a distortion rate in the front direction of about 0.55 and a distortion rate in a 60 degree oblique direction of about 0.05. Emitting light transmitted through the polarizing element (A1-1) was emitting linearly polarized light at a large incidence angle and the linearly polarized light had the polarization axis substantially perpendicular to the normal direction (the front) of a surface of the polarizing element.

($\frac{1}{2}$ Wavelength Plate (B))

[0249] A retardation film made of polycarbonate manufactured by NITTO DENKO CORPORATION (TR film) was employed. A front retardation value was 270 nm, N_z =about 1.0, a thickness was 35 μm and a retardation value was about +8% at 430 nm and a retardation value was about -5% at 650 nm.

(Retardation Layer (C))

[0250] A retardation layer (negative C plate) giving almost zero retardation to incident light in the front direction and a retardation to incident light in an oblique direction was prepared with a polymerizable liquid crystal. Employed were LC242 manufactured by BASF Ltd. as a polymerizable mesogen compound and LC756 manufactured by BASF Ltd. as a polymerizable chiral agent.

[0251] A polymerizable mesogen compound and a polymerizable chiral agent were mixed in a mixing ratio (wt ratio) of polymerizable mesogen compound to polymerizable chiral agent=100 to 2 so that a selective reflection central wavelength of an obtained cholesteric liquid crystal is about 1500 nm.

[0252] A concrete manufacturing method is as follows: A polymerizable chiral agent and a polymerizable mesogen compound were dissolved into toluene to prepare a mixture with a solute content of 20 wt %, into which added was a reaction initiator (IRGACURE 907 manufactured by Ciba Specialty Chemicals Inc., with a content of 1 wt % relative to the mixture) to prepare a solution. An alignment substrate was a polyethylene terephthalate film, alignment-treated with a rubbing cloth, with a trade name of Lumirror (with a thickness of 75 μm), manufactured by TORAY Industries Inc.

[0253] The solution was coated over the alignment substrate to a thickness of 4 μm after drying with a wire bar, a wet coat was dried at 90° C. for 2 min, thereafter the dried coat was heated once at an isotropic transition temperature of 130° C. and then cooled gradually. The cooled coat was irradiated with ultraviolet at a dose of 10 mW/cm² for 1 min in an environment at 80° C. for curing to obtain a negative C-plate. Retardations of the negative C-plate were measured with the results that the retardation in the front direction was given to light in the front direction with a wavelength of 550 nm was about 2 nm, while the retardation when a direction of incident light was inclined by 30 degrees was about 15 nm.

($\frac{1}{4}$ Wavelength Plate (D))

[0254] A WRF film manufactured by TEIJIN CHEMICALS LTD. (with the front retardation of 140 nm) was used. A retardation value at N_z =about 1, a retardation value at 430 nm was about +3% and a retardation value at 650 nm was about +1%.

(Linearly Polarized Light Reflection Polarizer (E))

[0255] DBEF manufactured by 3M Co. was employed.

(Optical Element (X))

[0256] As shown in FIG. 13, the polarizer (A1-1), the $\frac{1}{2}$ wavelength plate (B), the retardation layer (C), the $\frac{1}{4}$ wavelength plate (D), the linearly polarized light reflection polarizer (E) were laminated in the order using an acrylic-based pressure sensitive adhesive (with a product No. 7, manufactured by NITTO DENKO CORP. with a thickness of 25 μm) to obtain an optical element (X1). The transmission axis of the linearly polarized light reflection polarizer (E) was arranged so that the transmission axis thereof is the same as the polarization direction of linearly polarized light obtained by transmission through the $\frac{1}{4}$ wavelength plate (D).

(Characteristic Evaluation)

[0257] The optical element (X1) was placed on a diffusing light source with the polarizing element (A1-1) on the lower side and emitting light was measured. Results are shown in FIG. 20.

Example 2

(Polarizing Element (A))

[0258] A laminate made from cholesteric liquid crystals were obtained in a similar way to that in Example 1 with the exception that in Example 1, a polymerizable nematic liquid crystal monomer A and a polymerizable chiral agent B were used in the proportions (wt ratio) described below:

[0259] Selective reflection central wavelength: monomer A/chiral agent B (mixing ratio): selective reflection wavelength band (nm)

420 nm:	8/1	400 to 460 nm
460 nm:	9.2/1	430 to 490 nm
510 nm:	10.7/1	480 to 550 nm
580 nm:	12.8/1	540 to 620 nm
620 nm:	14/1	580 to 750 nm

[0260] The laminate of the obtained cholesteric liquid crystals had a selective reflection function in the wavelength range of from 400 to 750 nm. The laminate was indicated with (A1-2).

[0261] The polarizing element (A1-2) had a distortion rate in the front direction of about 0.65 and a distortion rate in a 60 degree oblique direction of about 0.03. Emitting light transmitted through the polarizing element (A1-2) was emitting linearly polarized light with a large incidence angle and the linearly polarized light had a polarization direction substantially perpendicular to the normal direction (front direction) of the surface of the polarizing element.

(Optical Element (X))

[0262] An optical element (X2) was obtained by laminating the polarizing element (A1-2), the $\frac{1}{2}$ wavelength plate (B), the retardation layer (C), the $\frac{1}{4}$ wavelength plate (D) and the linearly polarized light reflection polarizer (E) in the order using an acrylic-based pressure sensitive adhesive with a product No. 7, manufactured by NITTO DENKO CORP. and with a thickness of 20 μm in a similar way to that in Example 1 with the exception that the polarizing element (A1-2) was used instead of the polarizing element (A1-1) in Example 1.

(Characteristic Evaluation)

[0263] The optical element (X2) was placed on a diffusing light source with the polarizing element (A1-2) on the lower side and emitting light was measured. Results are shown in FIG. 21.

Example 3

(Polarizing Element (A))

[0264] A laminate made from cholesteric liquid crystals were obtained in a similar way to that in Example 1 with the exception that in Example 1, a polymerizable nematic liquid

crystal monomer A and a polymerizable chiral agent B were used in the proportions (wt ratio) described below:

[0265] Selective reflection central wavelength: monomer A/chiral agent B (mixing ratio): selective reflection wavelength band (nm)

390 nm:	7/1	400 to 460 nm
460 nm:	9.2/1	430 to 490 nm
510 nm:	10.7/1	480 to 550 nm
580 nm:	12.8/1	540 to 620 nm
660 nm:	14.7/1	620 to 810 nm
850 nm:	20/1	700 to 1000 nm

[0266] The laminate of the obtained cholesteric liquid crystals had a selective reflection function in the wavelength range of from 400 to 1000 nm. The laminate was indicated with (A1-3).

[0267] The polarizing element (A1-3) had a distortion rate in the front direction of about 0.68 and a distortion rate in a 60 degree oblique direction of about 0.03. Emitting light transmitted through the polarizing element (A1-3) was emitting linearly polarized light with a large incidence angle and the linearly polarized light had a polarization direction substantially perpendicular to the normal direction (front direction) of the surface of the polarizing element.

(Retardation Layer (C))

[0268] A retardation layer (negative C-plate) was fabricated with a polymerizable liquid crystal in a similar way to that in Example 1 with the exception that a mixing ratio (wt ratio) of a polymerizable mesogen compound to a polymerizable chiral agent=92 to 8 so that a selective reflection central wavelength of an obtained cholesteric liquid crystal is about 300 nm in Example 1. Retardations of the negative C-plate were measured with the results that a retardation given to light in the front direction at a wavelength of 550 nm was about 1 nm and a retardation given to light in a 30 degree oblique direction was about 220 nm. Four negative C-plates thus obtained were laminated to obtain a negative C-plate with a high retardation using an acrylic-based pressure sensitive material (with a product No. 7) manufactured by NITTO DENKO CORP. with a thickness of 25 μm .

(Optical Element (X))

[0269] An optical element (X2) was obtained by laminating the polarizing element (A1-3), the $\frac{1}{2}$ wavelength plate (B), the retardation layer (C), the $\frac{1}{4}$ wavelength plate (D) and the linearly polarized light reflection polarizer (E) in the order using an acrylic-based pressure sensitive adhesive with a product No. 7, manufactured by NITTO DENKO CORP. and with a thickness of 25 μm in a similar way to that in Example 1 with the exception that the polarizing element (A1-3) was used instead of the polarizing element (A1-1) and the above-mentioned retardation layer (C) was also used in Example 1.

(Characteristic Evaluation)

[0270] The optical element (X3) was placed on a diffusing light source with the polarizing element (A1-3) on the lower side and emitting light was measured. Results are shown in FIG. 22.

Comparative Example 1

[0271] An optical element was obtained by laminating the polarizing element (A1-1), the $\frac{1}{2}$ wavelength plate (B), the $\frac{1}{4}$ wavelength plate (D) and the linearly polarized light reflection polarizer (E) in the order using an acrylic-based pressure sensitive adhesive with a product No. 7, manufactured by NITTO DENKO CORP. and with a thickness of 25 μm in a similar way to that in Example 1 with the exception that the retardation layer (C) was not used in Example 1.

(Characteristic Evaluation)

[0272] The optical element was placed on a diffusing light source with the polarizing element (A1-1) on the lower side and emitting light was measured. Results are shown in FIG. 23.

[0273] In Table 1, there are compiled a brightness viewing angle characteristics of the optical elements obtained in Examples 1 to 3 and Comparative Example 1. Visual evaluation was performed in coloration in an oblique direction.

TABLE 1

	Condensation characteristic at a half value width	Coloration in an oblique direction
Example 1	± 44	▲
Example 2	± 40	○
Example 3	± 38	○○
Comparative Example 1	± 60	○

[0274] In the table, the following special marks are used, which are given with a specific evaluation each, ○○: very good, ○: good and ▲: somewhat bad

Example 6

(Polarizing Element (A))

[0275] Mixed together were 96 parts by wt of a photopolymerizable mesogen compound (a polymerizable nematic liquid crystal monomer) expressed by the following chemical structure 4,

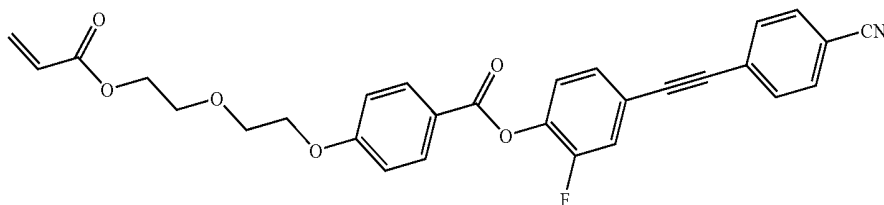

4 parts by wt of a polymerizable chiral agent (with a trade name of LC756, manufactured by BASF Ltd.) and an adjusted quantity of a solvent (methyl ethyl ketone) to thereby prepare a solution and further, added into the solution was 5 wt % of a photopolymerization initiator (with a trade name of IRGACURE 184, manufactured by Ciba Specialty Chemicals Inc.) relative to a solid matter of the solution to thereby obtain a coating liquid (with a solid matter content of 20 wt %). The coating liquid was cast on a stretched PET film (an alignment substrate) and the wet

coat was dried at 80° C. for 2 min and thereafter, another PET substrate was laminated. Then, the laminate was irradiated with ultraviolet at an intensity of 3 mW/cm² for 5 min while being heated at 120° C. to thereby obtain a cholesteric liquid crystal layer. Still another substrate was transferred on the surface of the one PET substrate using an isocyanate-based adhesive, while the other PET substrate was removed. The obtained cholesteric liquid crystal layer has a thickness of 9 μm and a selective reflection band in the range of from 430 nm to 860 nm.

[0276] A pitch length was measured on a sectional TEM photograph. A cholesteric pitch varies almost continuously in the thickness direction. The cholesteric liquid crystal layer was used as a polarizing element (A1-4).

[0277] The polarizing element (A1-4) had a distortion rate in the front direction of about 0.99 and a distortion rate in the 60 degree oblique direction of about 0.10. Emitting light transmitted through the polarizing element (A1-4) was linear polarized light in a case where an incidence angle was large and the linearly polarized light had the polarization axis in a direction substantially perpendicular to the normal direction (the front) of a surface of the polarizing element.

(Optical Element (X))

[0278] An optical element (X4) was obtained in a similar way to that in Example 1 with the exception that in Example 1, the polarizing element (A1-4) was employed instead of the polarizing element (A1-4).

(Evaluation of Characteristics)

[0279] The optical element (X4) was disposed on a diffusing light source and emitting light was measured. Results thereof are almost equal to those of Example 1.

Example 7

(Polarizing Element (A))

[0280] Mixed together were 96 parts by wt of a photopolymerizable mesogen compound (a polymerizable nematic liquid crystal monomer) expressed by the above chemical structure 4, 4 parts by wt of a polymerizable chiral agent

(with a trade name of LC756, manufactured by BASF Ltd.) and an adjusted quantity of a solvent (cyclopentanone) to thereby prepare a solution and thereafter, added into the solution was 0.5 wt % of a photopolymerization initiator (with a trade name of IRGACURE 907, manufactured by Ciba Specialty Chemicals Inc.) relative to a solid matter of the solution to thereby obtain a coating liquid (with a solid matter content of 30 wt %). The coating liquid was cast on a stretched PET film (an alignment substrate) with a wire bar so that a thickness of the coat after drying was 7 μm and the

wet coat was dried at 100° C. for 2 min to evaporate the solvent. Then, the obtained film was subjected to first irradiation with ultraviolet from the PET side at an intensity of 40 mW/cm² for 1.2 sec in an air atmosphere at 40° C. In succession, the laminate was further subjected to second irradiation at an intensity of 4 mW/cm² for 60 sec while being heated up to 90° C. at a temperature rise rate of 3° C./sec in an air atmosphere. Then, the laminate was subjected to a third irradiation with ultraviolet from the PET side at an intensity of 60 mW/cm² for 10 sec in a nitrogen atmosphere to thereby obtain a cholesteric liquid crystal layer with a selective reflection band in the range from 425 to 900 nm.

[0281] A pitch length was measured on a sectional TEM photograph. A cholesteric pitch varies almost continuously in the thickness direction. The cholesteric liquid crystal layer was used as a polarizing element (A1-5).

[0282] The polarizing element (A1-5) had a distortion rate in the front direction of about 0.99 and a distortion rate in the 60 degree oblique direction of about 0.10. Emitting light transmitted through the polarizing element (A1-5) was linear polarized light in a case where an incidence angle was large and the linearly polarized light had the polarization axis in a direction substantially perpendicular to the normal direction (the front) of the surface of the polarizing element.

(Optical Element (X))

[0283] An optical element (X5) was obtained in a similar way to that in Example 1 with the exception that in Example 1, a polarizing element (A1-5) was employed instead of the polarizing element (A1-1).

(Evaluation of Characteristics)

[0284] The optical element (X5) was disposed on a diffusing light source and emitting light was measured. Results thereof are almost equal to those of Example 1.

Example 8

(Polarizing Element (A))

[0285] Mixed together were 96 parts by wt of a photopolymerizable mesogen compound (a polymerizable nematic liquid crystal monomer) expressed by the above chemical structure 4, 4 parts by wt of a polymerizable chiral agent (with a trade name of LC756, manufactured by BASF Ltd.) and an adjusted quantity of a solvent (cyclopentanone) to thereby prepare a solution so that a selective reflection central wavelength was 550 nm and thereafter, added into the solution was 3 wt % of a photopolymerization initiator (with a trade name of IRGACURE 907, manufactured by Ciba Specialty Chemicals Inc.) relative to a solid matter of the solution to thereby obtain a coating liquid (with a solid matter content of 30 wt %). The coating liquid was cast on a stretched PET film (an alignment substrate) with a wire bar so that a thickness of the coat after drying was 6 μm and the wet coat was dried at 100° C. for 2 min to evaporate the solvent. Then, the obtained film was subjected to first irradiation with ultraviolet from the PET side at an intensity of 50 mW/cm² for 1 sec in an air atmosphere at 40° C. Thereafter, the laminate was heated at 90° C. for 1 min without applying irradiation with ultraviolet (a selective reflection band after heating was in the range of from 420 to 650 nm). Then, the laminate was subjected to second irra-

diation with ultraviolet at an intensity of 5 mW/cm² for 60 sec in an air atmosphere (a selective reflection band after irradiation was in the range of from 420 to 900 nm). Then, the laminate was subjected to third irradiation with ultraviolet from the PET side at an intensity of 80 mW/cm² for 30 sec in a nitrogen atmosphere to thereby obtain a cholesteric liquid crystal layer with a selective reflection band in the range from 425 to 900 nm.

[0286] A pitch length was measured on a sectional TEM photograph. A cholesteric pitch varies almost continuously in the thickness direction. The cholesteric liquid crystal layer was used as a polarizing element (A1-6).

[0287] The polarizing element (A1-6) had a distortion rate in the front direction of about 0.99 and a distortion rate in the 60 degree oblique direction of about 0.04. Emitting light transmitted through the polarizing element (A1-6) was linear polarized light in a case where an incidence angle was large and the linearly polarized light had the polarization axis in a direction substantially perpendicular to the normal direction (the front) of a surface of the polarizing element.

(Optical Element (X))

[0288] An optical element (X6) was obtained in a similar way to that in Example 1 with the exception that in Example 1, a polarizing element (A1-6) was employed instead of the polarizing element (A1-1).

(Evaluation of Characteristics)

[0289] The optical element (X6) was disposed on a diffusing light source and emitting light was measured. Results thereof are almost equal to those of Example 1.

Comparative Example 2

(Fabrication Method for Band Pass Filter)

[0290] A band pass filter shown in FIG. 24 and having a wavelength transmission characteristic was fabricated with an evaporation thin film.

TABLE 2

Layers	Materials	Film thicknesses [nm]
15	TiO ₂	92.1
14	SiO ₂	130.1
13	TiO ₂	68.3
12	SiO ₂	97.2
11	TiO ₂	63.2
10	SiO ₂	88.2
9	TiO ₂	152.1
8	SiO ₂	92.8
7	TiO ₂	70.7
6	SiO ₂	50.3
5	TiO ₂	148.6
4	SiO ₂	95.8
3	TiO ₂	65.5
2	SiO ₂	96.9
1	TiO ₂	65.3
	Glass Substrate	

[0291] As shown in Table 2, a band pass filter was fabricated with 15 layers each made of TiO₂ or SiO₂. A substrate was a PET film with a thickness of 50 μm and the total thickness was about 53 μm.

(Characteristic Evaluation)

[0292] The band pass filter was placed on a diffusing light source and emitting light was measured. Results of condensation characteristics as shown in FIG. 25 were obtained. The filter was left in an environment at an ordinary temperature and at an ordinary humidity for 3 months and thereafter, a transmission spectrum was measured with the results that the transmission spectrum after the passage of time changed from the initial transmission spectrum as shown in FIG. 24. This alteration in spectrum was considered to be caused by water absorption on a vapor deposited film due to moisture absorption. The sample was subjected to confirmation of a condensation characteristic in a similar way to that as described above and a change in condensation characteristic was observed as in a curve after the passage of time shown in FIG. 25. In such a way, a band pass filter with designated three wavelengths has been substantially regarded to have difficulty sustaining a wavelength characteristic thereof.

Comparative Example 3

[0293] A band pass filter was fabricated by thin-film coating of a cholesteric liquid crystal polymer. The band pass filter was fabricated by combining a right circularly polarized light reflective band pass filter with three designated wavelengths and a broad band left circular reflective polarizing plate. The band pass filter transmits circularly polarized light only with targeted three wavelengths in a direction in the vicinity of the normal direction, whereas reflecting circularly polarized light with the reverse rotational direction for recycling and reflecting incident light beams in oblique directions.

[0294] The circularly polarized light selectively reflective band pass filter reflecting right circularly polarized light with selective reflection wavelength bands in the range of from the 440 to 490 nm, in the range of from 540 to 600 nm and in the range of from 615 to 700 nm for emission spectra at wavelengths of 435 nm, 535 nm and 610 nm emitted from a three wavelength cold cathode tube was fabricated.

[0295] Manufactured were three kinds of cholesteric liquid crystal polymers, as liquid crystal materials that were used, with respective selective reflection central wavelengths of 480 nm, 550 nm and 655 nm based on EP 0834754 A1 in a similar way to that in Example 1. The cholesteric liquid crystal polymers were prepared by polymerizing liquid crystal mixtures containing the polymerizable nematic liquid crystal monomer A (chemical structure 2) and the polymerizable chiral agent B' (mirror image isomer of the chemical structure 3), which were used in Example 1, at the rates (wt ratios) described below:

[0296] selective reflection central wavelength: monomer A/chiral agent B' (mixing ratio)

480 nm:	9.81/1
550 nm:	11.9/1
655 nm:	14.8/1

[0297] The liquid crystal mixture was dissolved into tetrahydrofuran to obtain a 33% solution, thereafter, the solution was purged with nitrogen in a circumstance at 60° C.,

then, a reaction initiator (azobisisobutyronitrile, 0.5 wt % relative to the mixture) was added into the solution and polymerization was performed. An obtained polymer was subjected to reprecipitation separation with diethyl ether to thereby purify the polymer.

[0298] The cholesteric liquid crystal polymer was dissolved into methylene chloride to prepare a 10 wt % solution. The solution was coated on an alignment substrate to a thickness of about 1.5 μm after drying with a wire bar. A polyethylene terephthalate (PET) film with 75 μm in thickness and a polyimide alignment film was coated to a thickness of about 0.1 μm and rubbed with a layon rubbing cloth was used as an alignment substrate. The rubbed alignment film after coating was dried at 140° C. for 15 min. After the heat treatment, a liquid crystal was fixedly cooled thereon at room temperature to obtain a thin film.

[0299] Cholesteric liquid crystal thin films in each colors were obtained applying similar steps thereto and the thin films were adhered to one another with an isocyanate-based adhesive (with a product No. of AD 126 manufactured by TOKUSHIKI Co., Ltd.) and thereafter, the PET substrate was removed, wherein the three cholesteric liquid crystal layers are laminated in the order starting from the shorter wavelength side through repetition of the steps to thereby obtain a cholesteric liquid crystal laminate (band pass filter) with a thickness of about 5 μm. In FIG. 26, there is shown a transmittance of the obtained cholesteric liquid crystal laminate: The laminate of cholesteric liquid crystals had a distortion rate in the front direction of about 0.90 and a distortion rate in a 60 degree oblique direction of about 0.54.

[0300] A NIPOCS film manufactured by NITTO DENKO CORP. (attached with PCF400-SEG1465DU) was laminated on the cholesteric liquid crystal laminate (band pass filter). The film was a polarizing plate, which was used for a purpose to improve brightness, is a polarizing plate attached with a circularly polarized light reflection plate, which was inserted a ¼ wavelength plate between the polarizing plate and the circularly polarizing plate. A single piece band pass filter was obtained by adhering the cholesteric liquid crystal surfaces so as to face each other.

(Characteristic Evaluation)

[0301] The band pass filter was placed on a diffusing light source and emitting light was measured. The band pass filter had a condensation characteristic having a half value width of the order of ±15 degrees, whereas a steep reduction in brightness occurred to feel a change in tone when visually observed in an oblique direction. This is thought because set values of transmission wavelengths do not coincide exactly with bright-line spectra of a light source and shielding effects are thereby differentiated in levels therebetween in company with changes in angle.

Comparative Example 4

[0302] Measurement of emitting light was conducted on a TFT liquid crystal display (with a model No. LQ10D362/10.4/TFT) manufactured by Sharp Corp. which used a conventional sidelight type light guide plate. Results are shown in FIG. 27. It is found that a peak of emitting light is shifted slightly from the front direction.

Comparative Example 5

[0303] A sample described below was manufactured according to an example described in WO 03/27756 A1. A

rotatory polarizer *r* was adhered to the linearly polarized light reflection polarizer (E) used in Example 1 and the linearly polarized light reflection polarizer (E) was adhered to the rotatory polarizer. An acrylic-based pressure sensitive adhesive NO. 7 (with a thickness of 25 μm) manufactured by NITTO DENKO CORPORATION was used for adhesion and the polarized light transmission axes were almost parallel to each other.

[0304] The rotatory polarizer was manufactured in a way described below. A liquid crystal monomer (LC242, manufactured by BASF Ltd.), a chiral agent (LC756, manufactured by BASF Ltd.) and a polymerization initiator (IRGACURE 369, manufactured by Ciba Specialty Chemicals Inc.) at a wt ratio of LC242/LC756/IRGACURE 369=96.4/0.1/3.5 were dissolved into a solvent (methyl ethyl ketone) to thereby prepare a 20 wt % solution. A wire bar coater was used and the solution was coated on a PET substrate (Lumirror, manufactured by TORAY INDUSTRIES Inc. with a thickness of 75 μm), the wet coat was heated at 80° C. for 2 min to remove the solvent by evaporation and the coat was polymerized and cured with an ultraviolet irradiator in an atmosphere after nitrogen gas purge. A thickness of the obtained cured liquid crystal was about 6 μm . An optical rotatory power of the sample was about 85 degrees.

[0305] A polarizing element obtained by laminating the linearly polarized light reflection polarizer (E), the rotatory polarizer and the linearly polarized light reflection polarizer (E) has a selective reflection function in the range of from 380 to 1100 nm. The laminate of cholesteric liquid crystal has a distortion rate of 0.01 or less in the front direction and a distortion rate of 0.01 or less in a 60 degree oblique direction and no unique incidence angle dependence occur with respect to transmittance. The polarizing element shows a performance almost equal to that of a polarizing element obtained by adhering DBEF to DBEF at an axis angle of about 85 degrees.

INDUSTRIAL APPLICABILITY

[0306] An optical element of the present invention using a polarizing element is suitably applied to a light condensation backlight system, further to a liquid crystal display.

1. An optical element comprising:

a polarizing element (A), separating incident light into polarization to then emit light, and made of a cholesteric liquid crystal, wherein

the polarizing element (A) has a distortion rate with respect to emitting light to incident light in the normal direction of 0.5 or more and

a distortion rate with respect to emitting light to incident light at an angle inclined from the normal direction by 60 degrees or more of 0.2 or less,

the polarizing element (A) has a function increasing a linearly polarized light component of emitting light as incidence angle is larger;

a $\frac{1}{2}$ wavelength plate (B);

a retardation layer (C) giving almost zero retardation to incident light in the front direction (normal direction) and giving a retardation to incident light in a direction inclined from the normal direction; and

a $\frac{1}{4}$ wavelength plate (D); being arranged in this order,

and further a linearly polarized light reflection polarizer (E), transmitting linearly polarized light with one polarization axis and selectively reflecting linearly polarized light with the other polarization axis perpendicular to the one polarization axis, is arranged on the $\frac{1}{4}$ wavelength plate (D) so that the transmission axis of the linearly polarized light reflection polarizer (E) and an axis of the transmitted light, which is transmitted through the polarizing element (A) to the $\frac{1}{4}$ wavelength plate (D) in this order, are the same direction.

2. The optical element according to claim 1, wherein, in the polarizing element (A), the linearly polarized light component of emitting light increasing as incidence angle is larger has a polarization axis of linearly polarized light substantially perpendicular to the normal direction of a surface of the polarizing element.

3. The optical element according to claim 1, wherein, in the polarizing element (A), the linearly polarized light component of emitting light increasing as incidence angle is larger has a polarization axis of linearly polarized light substantially parallel to the normal direction of a surface of the polarizing element.

4. The optical element according to claim 1, wherein the polarizing element (A) substantially reflects a non-transmission component of incident light.

5. The optical element according to claim 1, wherein a thickness of the polarizing element (A) is 2 μm or more.

6. The optical element according to claim 1, wherein a reflection band width of the polarizing element (A) is 200 nm or more.

7. The optical element according to claim 1, wherein the $\frac{1}{2}$ wavelength plate (B) is a broad band wavelength plate working as an almost $\frac{1}{2}$ wavelength plate over the entire visible light band.

8. The optical element according to claim 7, wherein the $\frac{1}{2}$ wavelength plate (B) has a front retardation values, which is expressed by $(n_x - n_y) \times d$, in the range of a $\frac{1}{2}$ wavelength $\pm 10\%$ at wavelengths in the light source wavelength band (ranging from 420 to 650 nm),

where a direction in which an in-plane refractive index is maximized is defined as X axis and a direction perpendicular to the X axis is defined as Y axis, where refractive indices in each axis directions are defined as n_x and n_y , respectively, and a thickness is defined as d (nm).

9. The optical element according to claim 1, wherein the $\frac{1}{2}$ wavelength plate (B) controls a retardation in the thickness direction and reduces a change in retardation caused by a change in angle.

10. The optical element according to claim 9, wherein the $\frac{1}{2}$ wavelength plate (B) has an N_z coefficient, which is expressed by $N_z = (n_x - n_z) / (n_x - n_y)$, in a relation of $-2.5 < N_z \leq 1$,

where a direction in which an in-plane refractive index is maximized is defined as X axis, a direction perpendicular to the X axis is defined as Y axis and a thickness direction of the film is defined as Z axis, where refractive indices in each axis directions are defined as n_x , n_y and n_z .

11. The optical element according to claim 1, wherein the retardation layer (C) is at least one selected from the group consisting of:

a layer of a cholesteric liquid crystal phase having a selective reflection wavelength band in a range other than the visible light range and having a fixed planar alignment;

a layer of a rod-like liquid crystal having a fixed homeotropic alignment state;

a layer of a discotic liquid crystal having a fixed alignment state of a nematic phase or a columnar phase;

a layer of a biaxially-oriented polymer film;

a layer of a negative uniaxial inorganic layered compound having an optical axis aligned and fixed in the normal direction of a plane; and

a film produced with at least one polymer selected from the group consisting of polyamide, polyimide, polyester, poly(etherketone), poly(amide-imide), and poly(ester-imide).

12. The optical element according to claim 1, wherein the $\frac{1}{4}$ wavelength plate (D) is a broad band wavelength plate working as an almost $\frac{1}{4}$ wavelength plate over the entire visible light band.

13. The optical element according to claim 12, wherein the $\frac{1}{4}$ wavelength plate (D) has a front retardation values, which is expressed by $(n_x - n_y) \times d$, in the range of a $\frac{1}{4}$ wavelength $\pm 10\%$ at wavelengths in the light source wavelength band (ranging from 420 to 650 nm),

where a direction in which an in-plane refractive index is maximized is defined as X axis and a direction perpendicular to the X axis is defined as Y axis, where refractive indices in each axis directions are defined as n_x and n_y , respectively, and a thickness is defined as d (nm).

14. The optical element according to claim 1, wherein the $\frac{1}{4}$ wavelength plate (D) has an N_z coefficient, which is expressed by $N_z = (n_x - n_z) / (n_x - n_y)$, in a relation of $-2.5 < N_z \leq 1$,

where a direction in which an in-plane refractive index is maximized is defined as X axis, a direction perpendicular to the X axis is defined as Y axis and a thickness direction of the film is defined as Z axis, where refractive indices in each axis directions are defined as n_x , n_y and n_z .

15. The optical element according to claim 1, wherein the linearly polarized light reflection polarizer (E) is a grid type polarizer.

16. The optical element according to claim 1, wherein the linearly polarized light reflection polarizer (E) is a multi-layer thin film laminate with two or more layers made of two or more kinds of materials having a difference between refractive indices.

17. The optical element according to claim 16, wherein the thin multilayer laminate is a vapor-deposited thin film.

18. The optical element according to claim 1, wherein the linearly polarized light reflection polarizer (E) is a multi-birefringence layer thin film laminate with two or more layers made of two or more kinds of materials each having a birefringence.

19. The optical element according to claim 18, wherein the thin multilayer laminate is a stretched resin laminate with two or more layers containing two or more kinds of resins each having a birefringence.

20. The optical element according to claim 1, wherein a polarizing plate is disposed outside of the linearly polarized light reflection polarizer (E) so that the polarized light transmission axis of the linearly polarized light reflection polarizer (E) and the polarization axis direction of the polarizing plate coincide with each other.

21. The optical element according to claim 1, wherein layers are laminated with a transparent adhesive or pressure sensitive adhesive.

22. A light condensation backlight system, in which at least a light source is provided for the optical element according to claim 1.

23. (canceled)

24. (canceled)

25. A light condensation backlight system, in which at least a light source is provided for the optical element according to claim 20.

26. A liquid crystal display, in which at least a liquid crystal cell is provided for the light condensation backlight system according to claim 25.

27. The liquid crystal display according to claim 26, comprising a diffusing plate neither backscattering nor depolarizing laminated on the viewing side of the liquid crystal cell.

* * * * *

专利名称(译)	光学元件，光凝聚背光系统和液晶显示器		
公开(公告)号	US20070064168A1	公开(公告)日	2007-03-22
申请号	US10/576772	申请日	2004-08-24
[标]申请(专利权)人(译)	日东电工株式会社		
申请(专利权)人(译)	日东电工株式会社		
当前申请(专利权)人(译)	日东电工株式会社		
[标]发明人	SHIRAOGAWA MIKI TAKEDA KENTAROU HARA KAZUTAKA TAKAHASHI NAOKI		
发明人	SHIRAOGAWA, MIKI TAKEDA, KENTAROU HARA, KAZUTAKA TAKAHASHI, NAOKI		
IPC分类号	G02F1/1333 G02B5/30 F21S2/00 F21S8/04 F21V8/00 F21Y103/00 G02B27/28 G02F1/13357		
CPC分类号	G02B27/28 G02B6/0056		
优先权	2003363241 2003-10-23 JP		
外部链接	Espacenet USPTO		

摘要(译)

一种光学元件，包括：偏振元件 (A)，将入射光分离成偏振然后发光，并且由胆甾型液晶制成，其中，偏振元件 (A) 具有相对于向入射光发射光的失真率。0.5° 以上的法线方向和相对于以法线方向倾斜60度或更大的角度入射光的入射光的失真率为0.2或更小，偏振元件 (A) 具有增加线性偏振的功能入射角的发光光分量较大; 1/2波长板 (B); 延迟层 (C) 使入射光在正面方向 (法线方向) 上几乎没有延迟，并且使入射光在从法线方向倾斜的方向上延迟; 和1/4波长板 (D); 按顺序排列，并且线性偏振光反射偏振器 (E)，其传输具有一个偏振轴的线性偏振光并选择性地反射线性偏振光，其中另一个偏振轴垂直于一个偏振轴，被布置在1/4波长板上板 (D) 使得线性偏振光反射偏振器 (E) 的透射轴和透射光的轴 (其通过偏振元件 (A) 按此顺序透射到1/4波长板 (D)) 是同一个方向。光学元件能够聚集和准直来自光源的入射光，并且能够抑制光在任意方向上的透射。

