



US006956633B2

(12) **United States Patent**
Okada et al.

(10) **Patent No.: US 6,956,633 B2**
(45) **Date of Patent: Oct. 18, 2005**

(54) **ACTIVE MATRIX TYPE LIQUID CRYSTAL DISPLAY APPARATUS**

(75) Inventors: **Yoshihiro Okada**, Soraku-gun (JP);
Atsushi Ban, Nara (JP)

(73) Assignee: **Sharp Kabushiki Kaisha**, Osaka (JP)

(*) Notice: Subject to any disclaimer, the term of this patent is extended or adjusted under 35 U.S.C. 154(b) by 87 days.

5,040,875 A	8/1991	Noguchi	
5,406,398 A	4/1995	Suzuki et al.	
5,535,028 A	7/1996	Bae et al.	
5,831,708 A *	11/1998	Hiraishi et al.	349/143
5,953,088 A *	9/1999	Hanazawa et al.	349/110
6,172,729 B1	1/2001	Ikeda	
6,320,636 B2 *	11/2001	Zhang et al.	349/139
6,525,798 B1	2/2003	Yamakita et al.	
6,538,713 B1	3/2003	Yanagawa et al.	
6,633,360 B2 *	10/2003	Okada et al.	349/145
6,724,452 B1 *	4/2004	Takeda et al.	349/139
6,781,658 B1 *	8/2004	Choi	349/139

(21) Appl. No.: **10/624,935**

(22) Filed: **Jul. 21, 2003**

(65) **Prior Publication Data**

US 2004/0017521 A1 Jan. 29, 2004

Related U.S. Application Data

(62) Division of application No. 09/821,717, filed on Mar. 29, 2001, now Pat. No. 6,633,360.

(30) **Foreign Application Priority Data**

Mar. 30, 2000	(JP)	2000-094314
Mar. 30, 2000	(JP)	2000-094330

(51) **Int. Cl.⁷** **G02F 1/1343**

(52) **U.S. Cl.** **349/139; 349/143; 349/44**

(58) **Field of Search** 349/143, 139,
349/44, 43, 38, 110

(56) **References Cited**

U.S. PATENT DOCUMENTS

4,783,149 A 11/1988 Umeda et al.

FOREIGN PATENT DOCUMENTS

JP	4121712	4/1992
JP	06250220 A	9/1994
JP	9090318	4/1997
JP	10253988	9/1998

* cited by examiner

Primary Examiner—Toan Ton

(74) *Attorney, Agent, or Firm*—David G. Conlin; William J. Daley, jr.; Edwards & Angell, LLP

(57) **ABSTRACT**

In an active matrix type liquid crystal display apparatus, each of pixel electrodes has overhanging portions at its opposite side edges. These overhanging portions of the pixel electrode cover two signal lines placed on opposite sides of the pixel electrode, respectively.

16 Claims, 21 Drawing Sheets

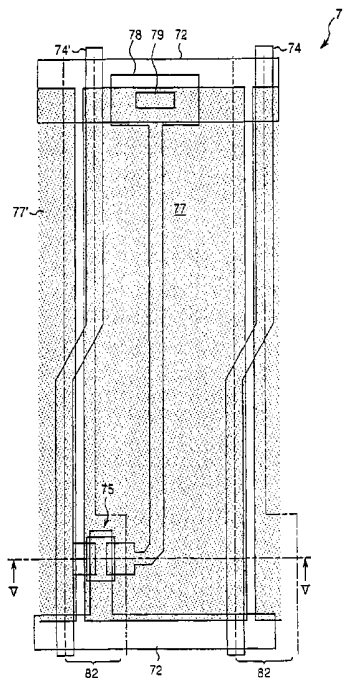

Fig. 1

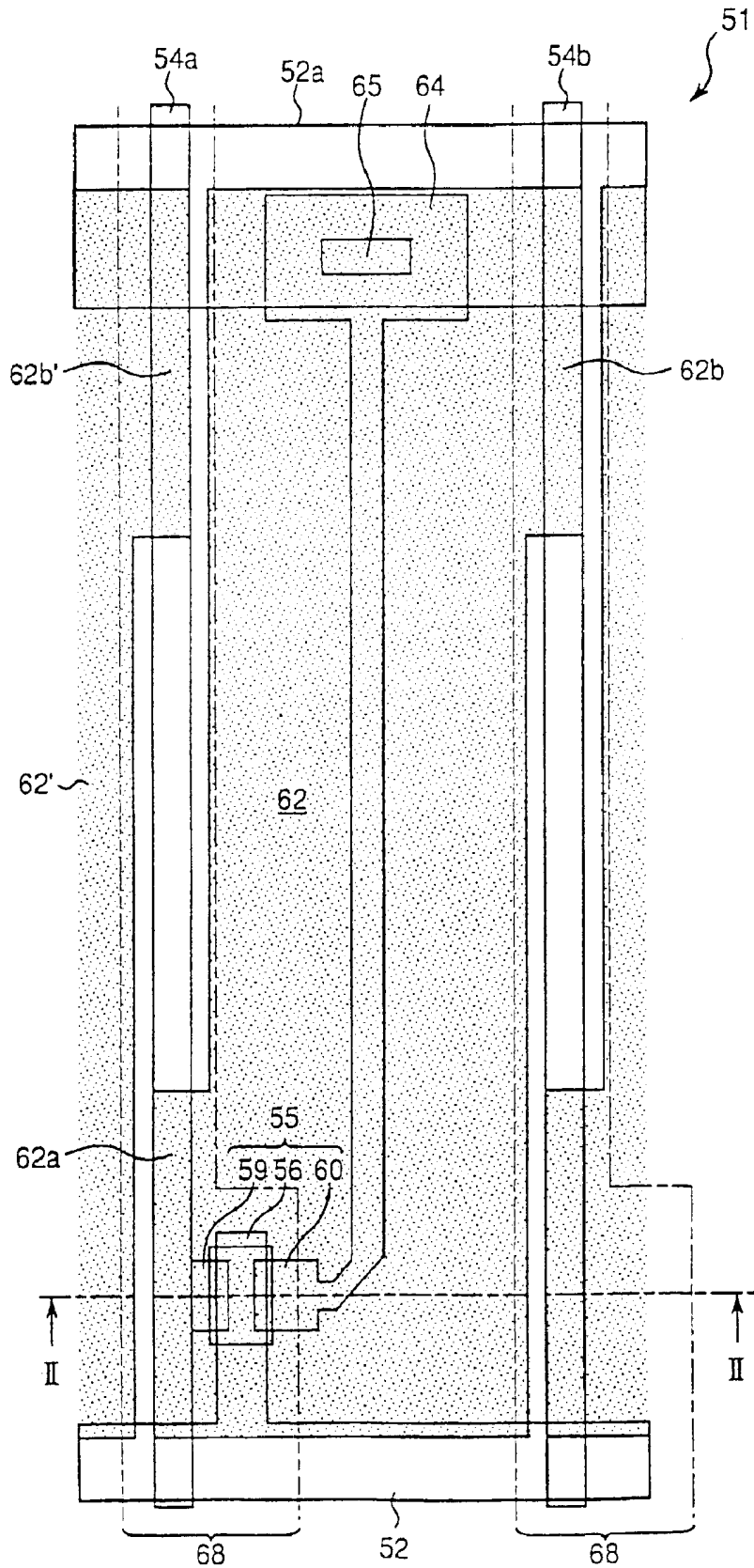

Fig.2

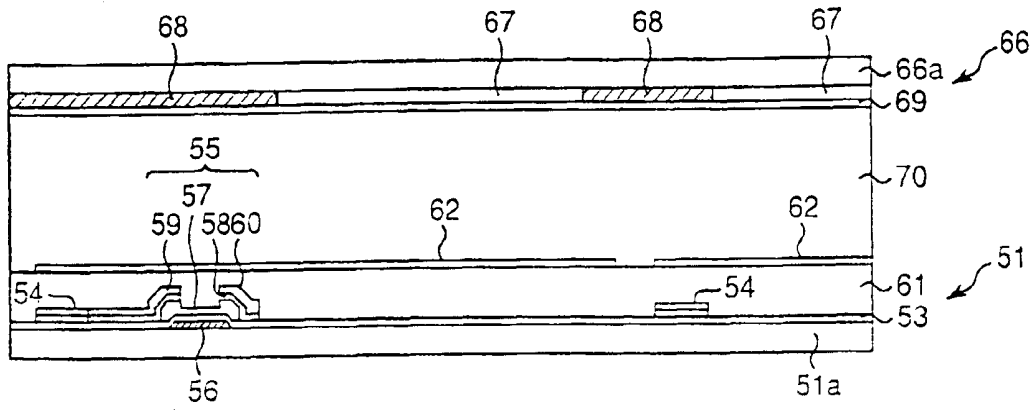

Fig.3

AMOUNT OF CHANGE OF (Csd1—Csd2)
RELATIVE TO ALIGNMENT DEVIATION dx

dx(μm)	CONVENTIONAL STRUCTURE	EMBODIMENT
0.0	0.0%	0.0%
0.7	9.4%	2.2%
1.0	13.4%	3.3%

Fig. 4

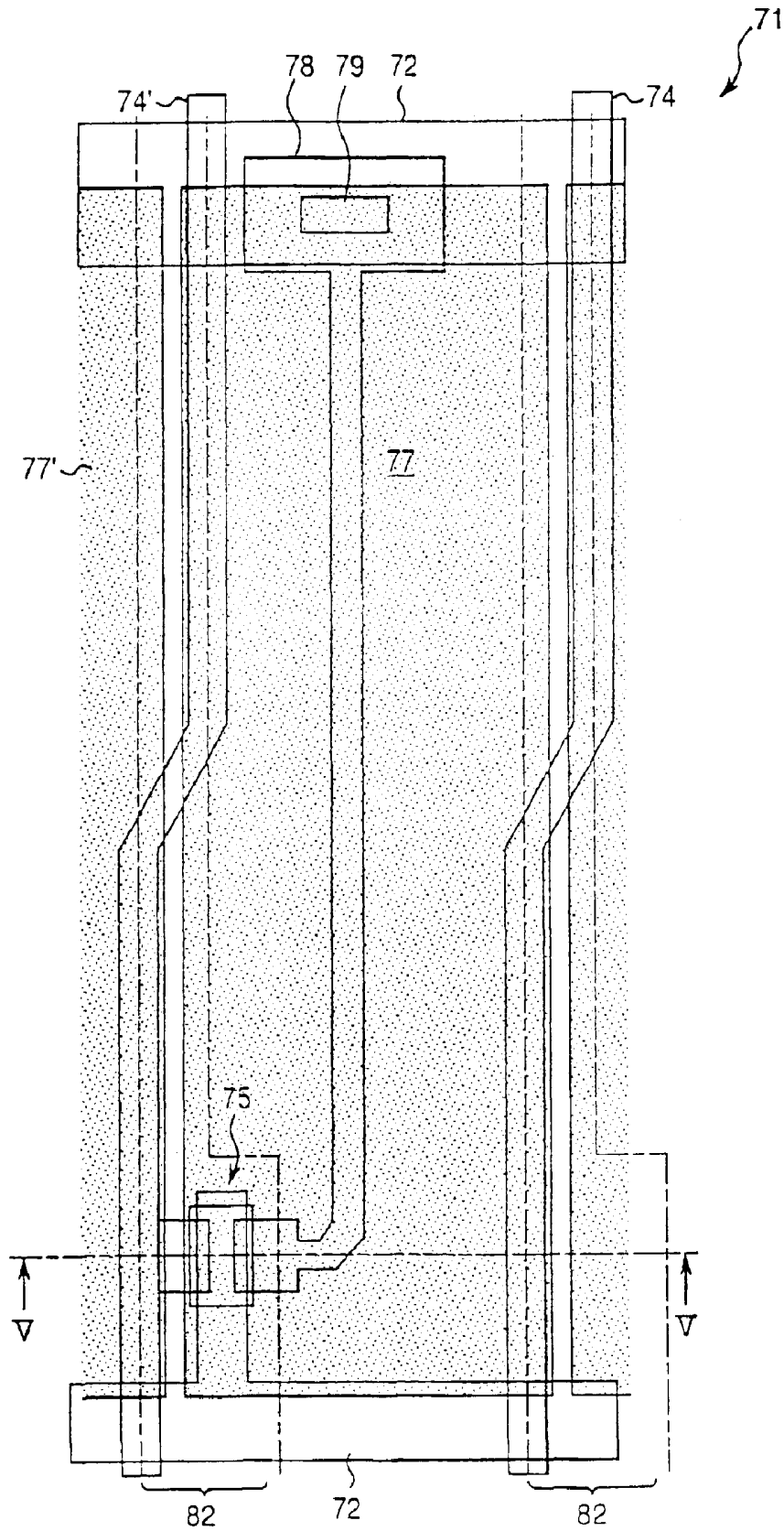

Fig.5

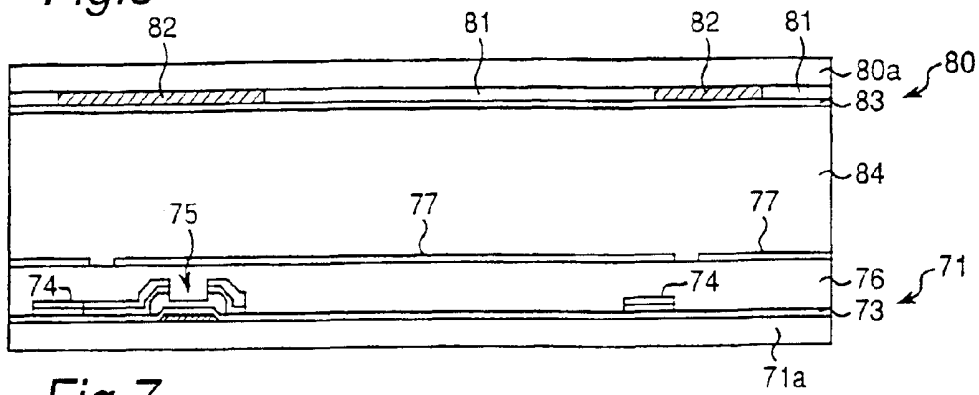

Fig.7

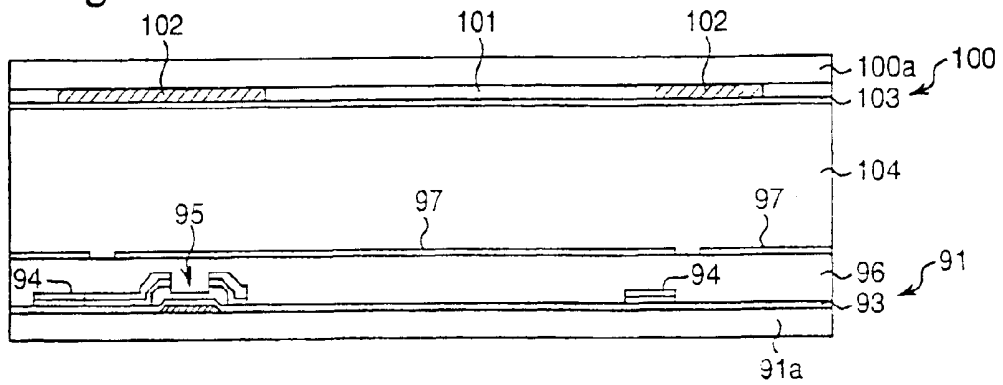

Fig.9

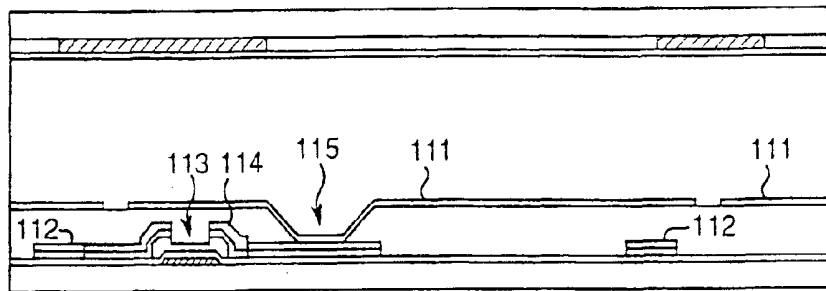

Fig11

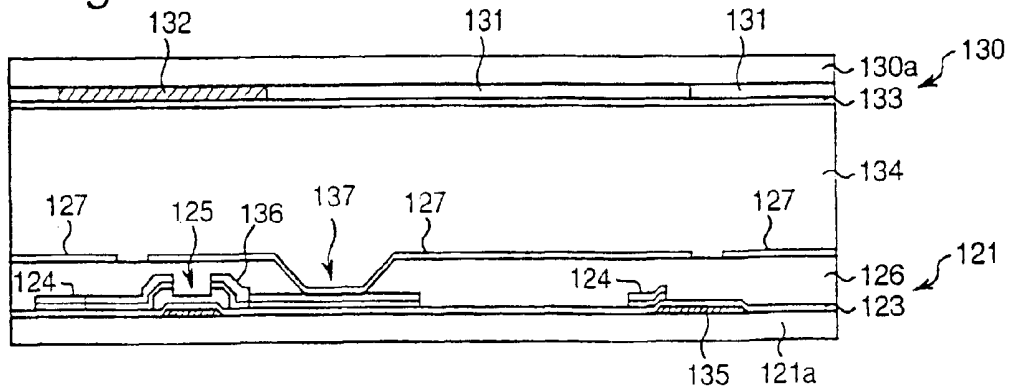

Fig. 6

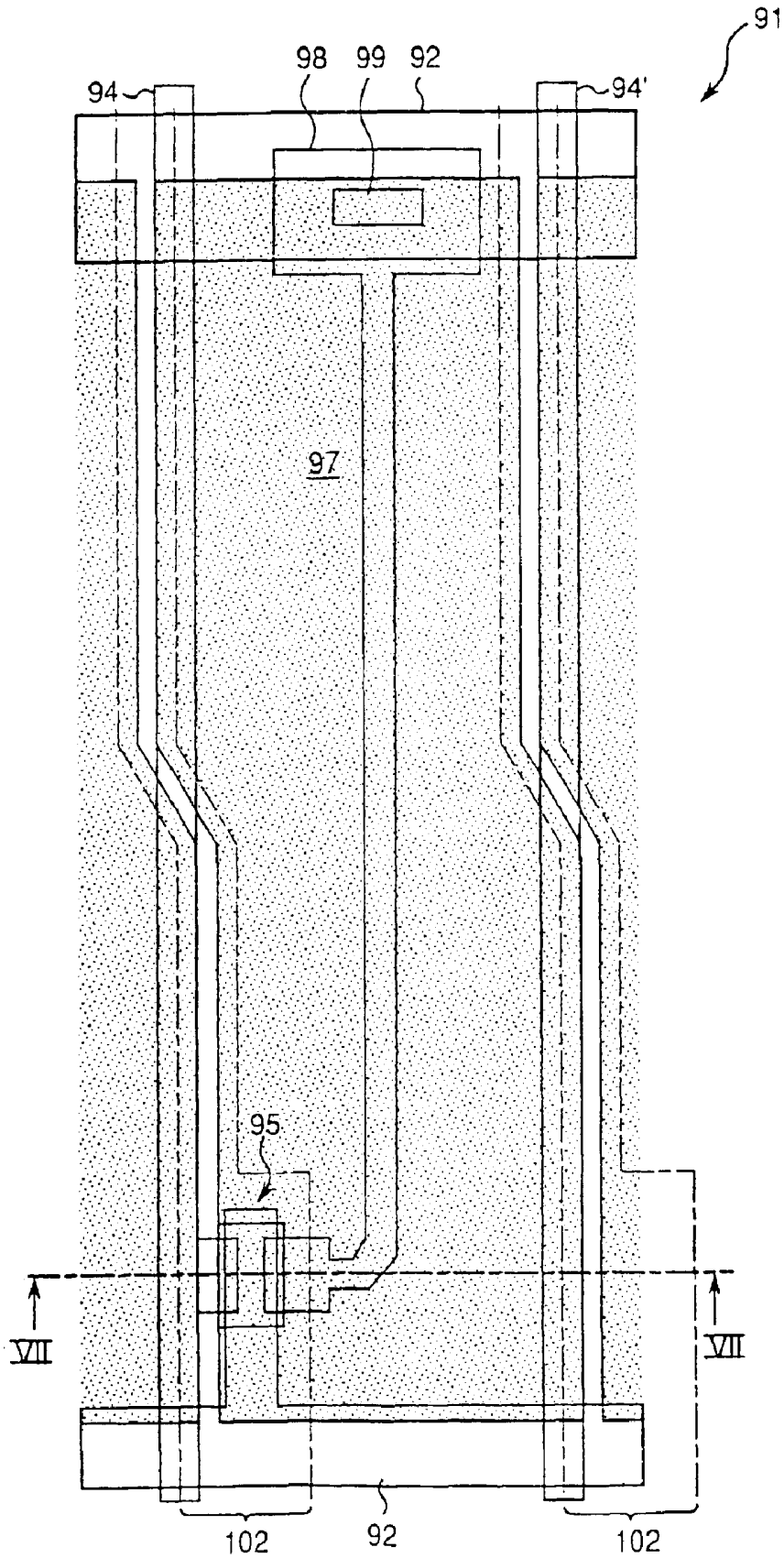

Fig. 8

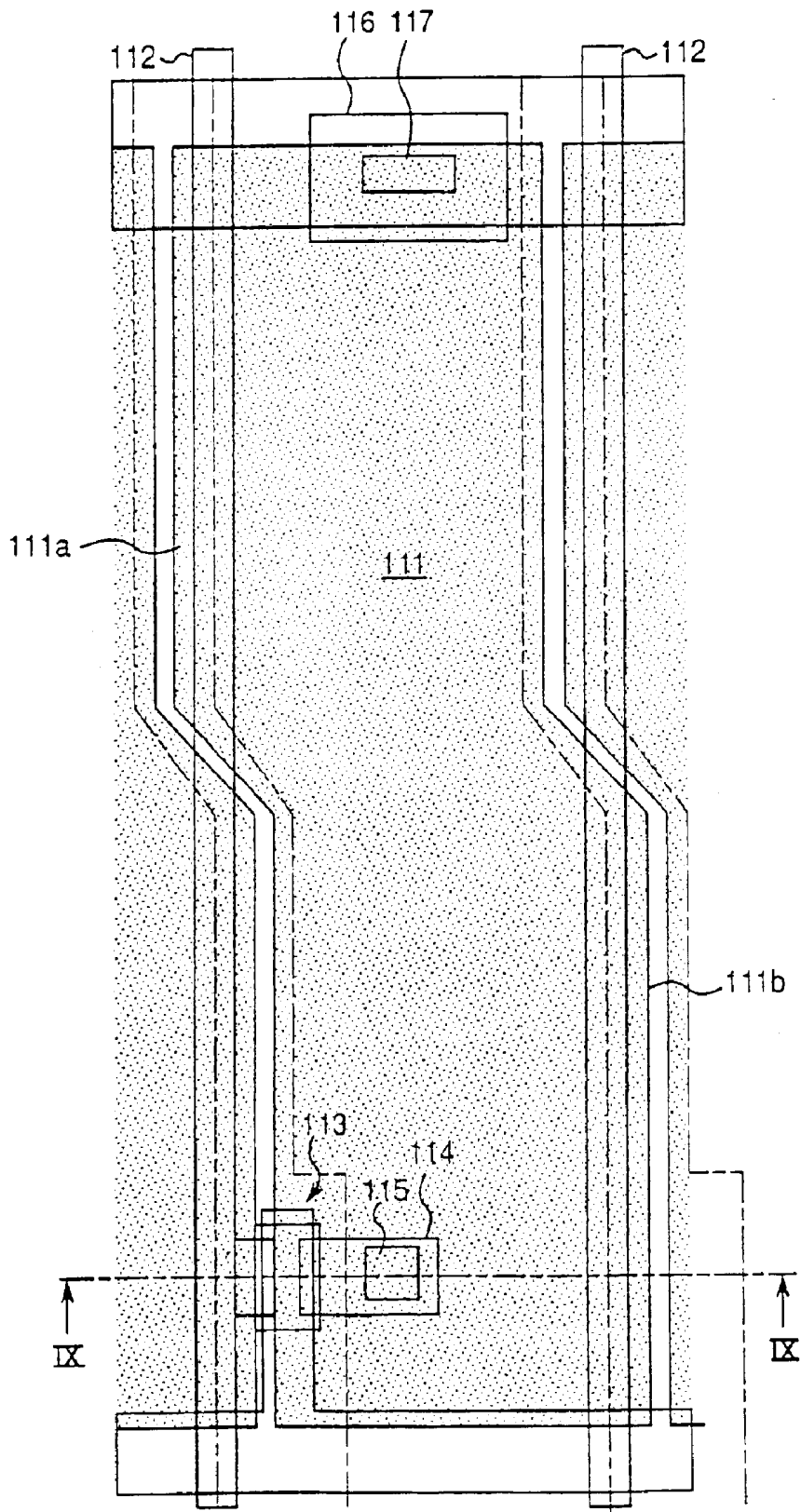

Fig. 10

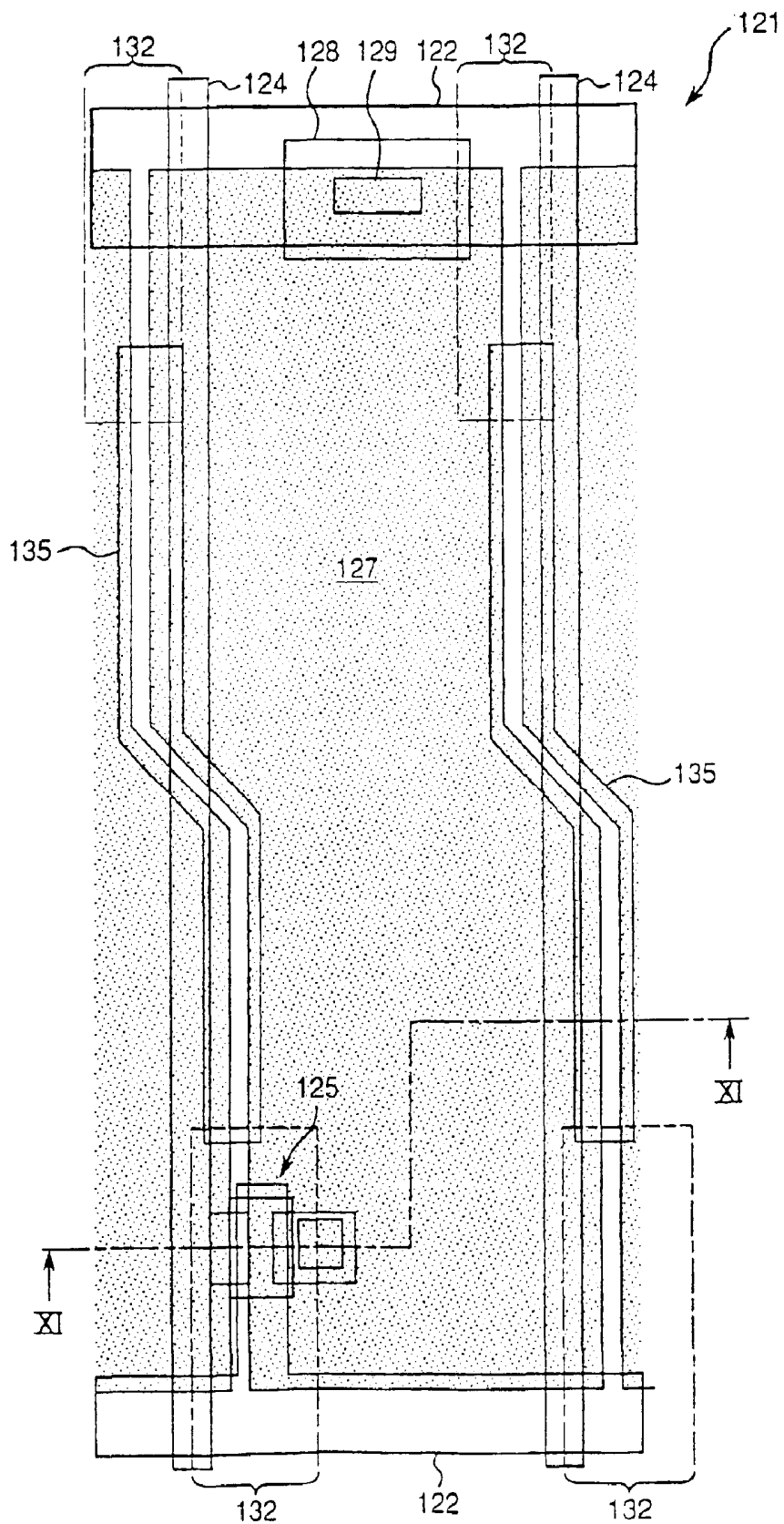

Fig. 12

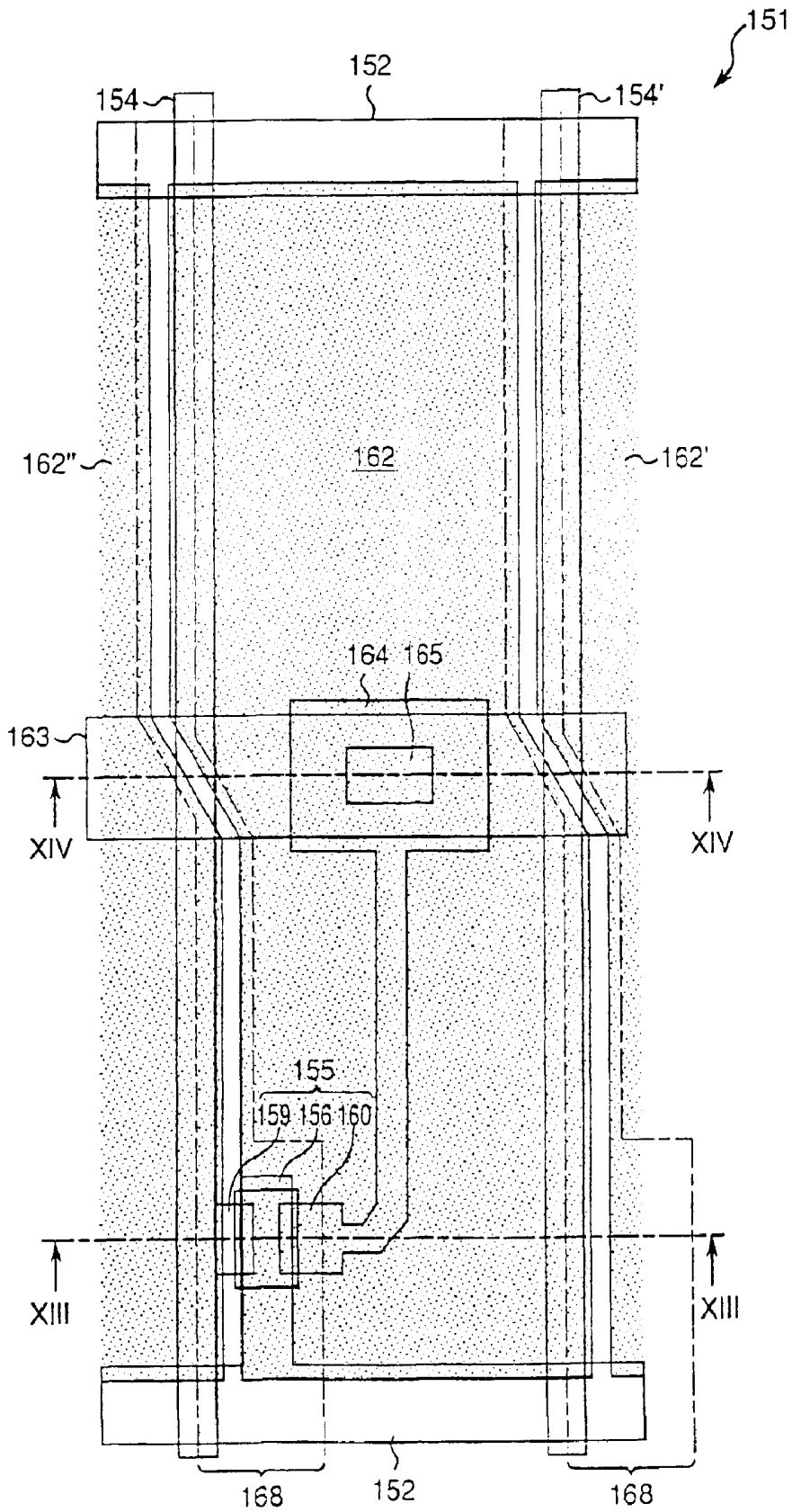

Fig. 13

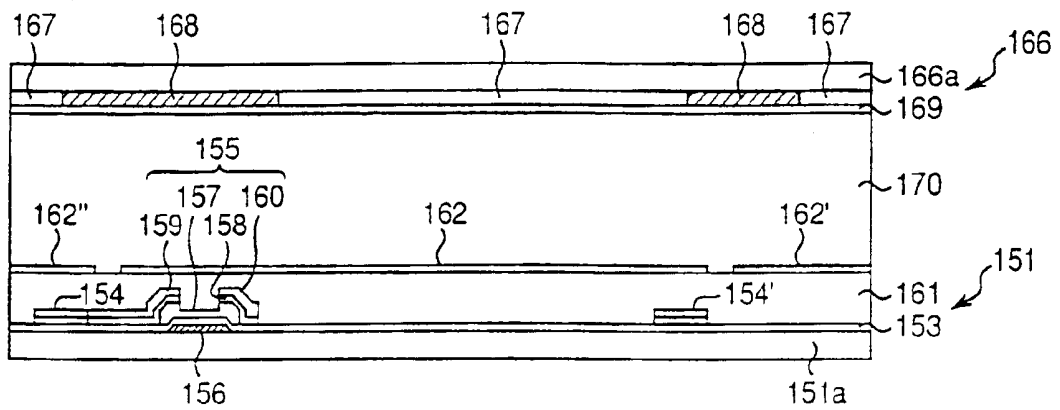

Fig. 14

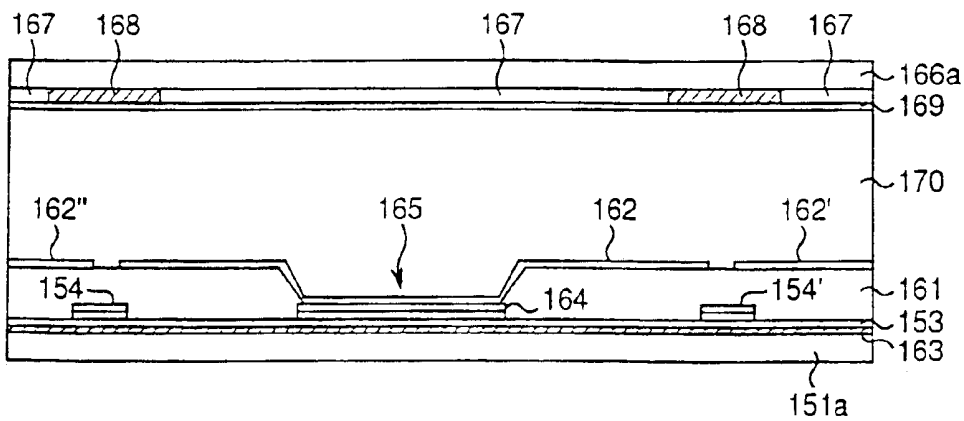

Fig. 15

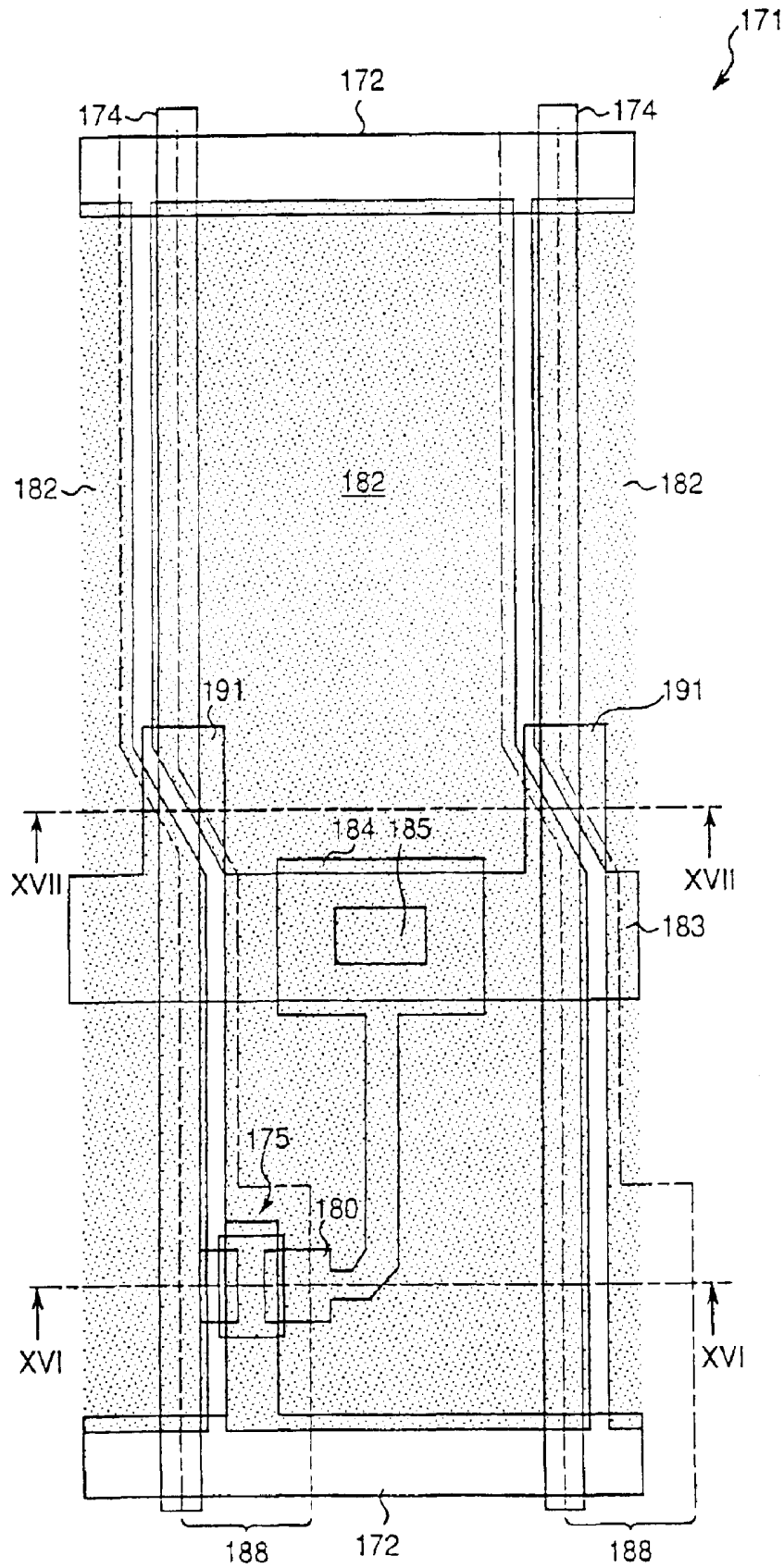

Fig. 16

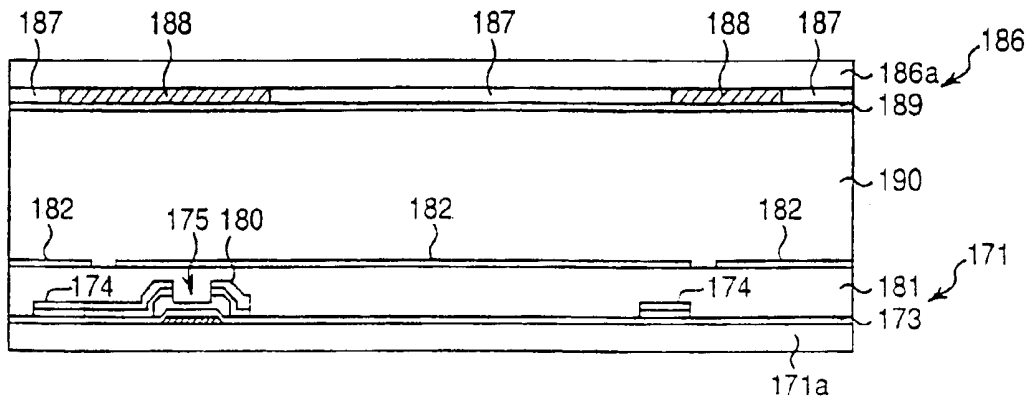

Fig. 17

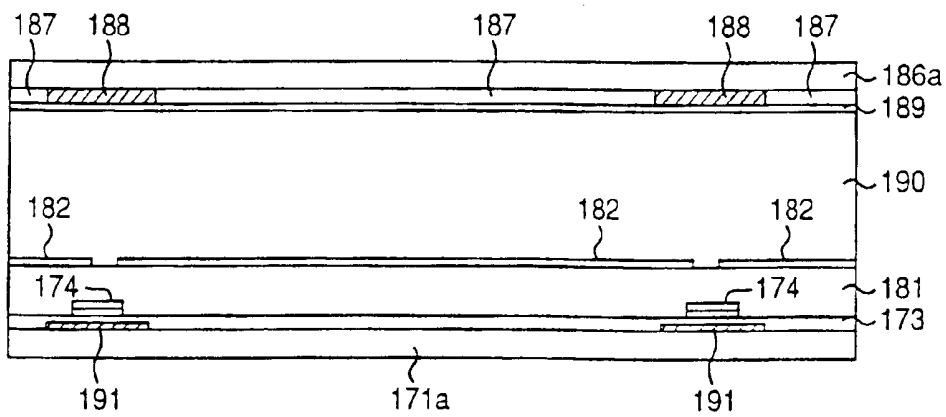

Fig. 18

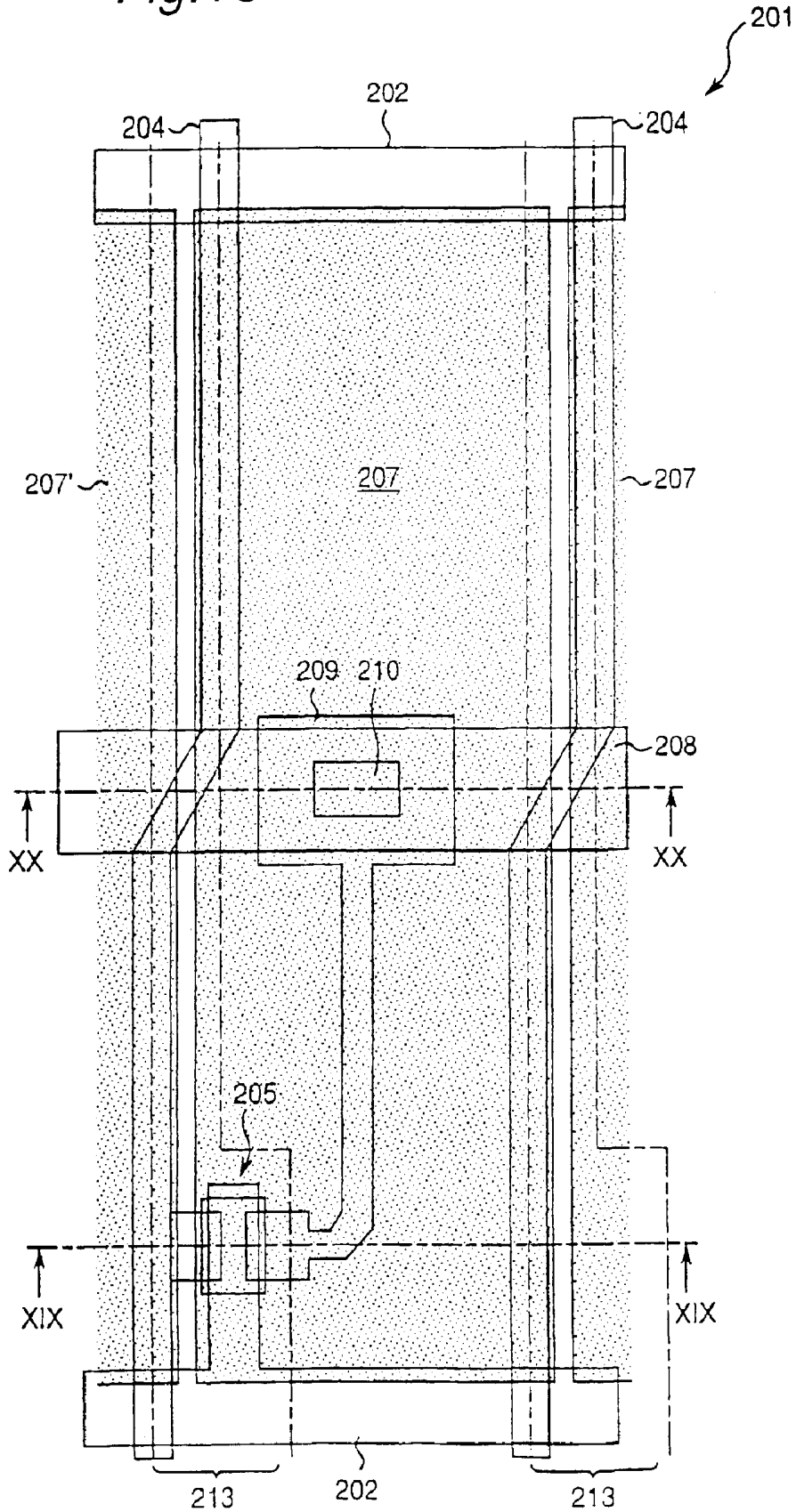

Fig.19

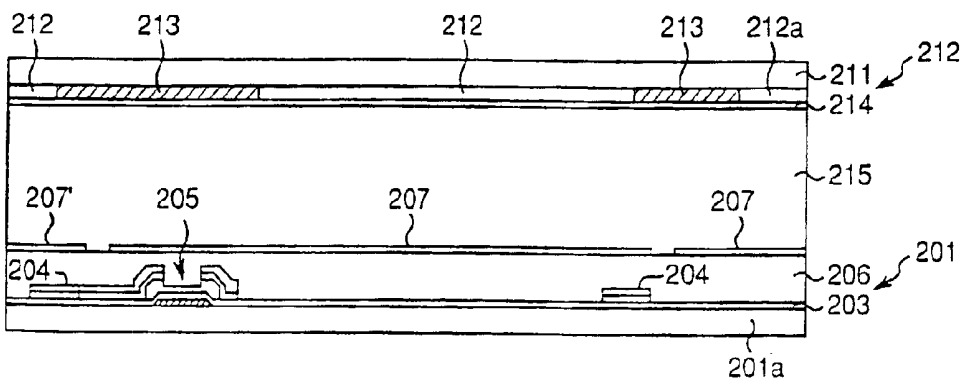

Fig.20

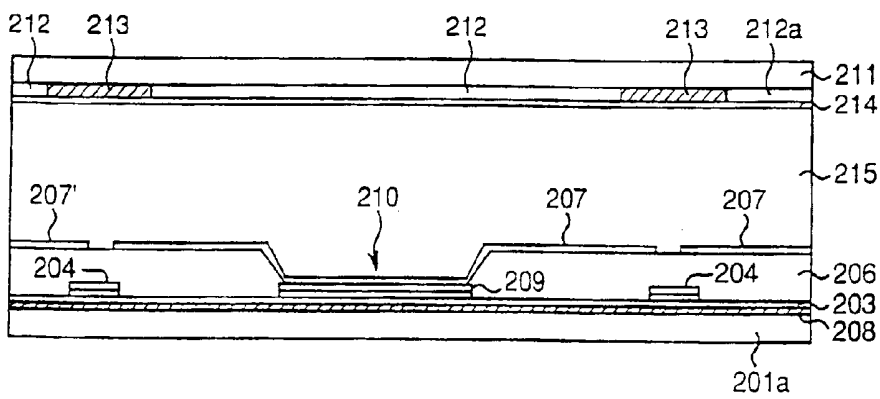

Fig. 21

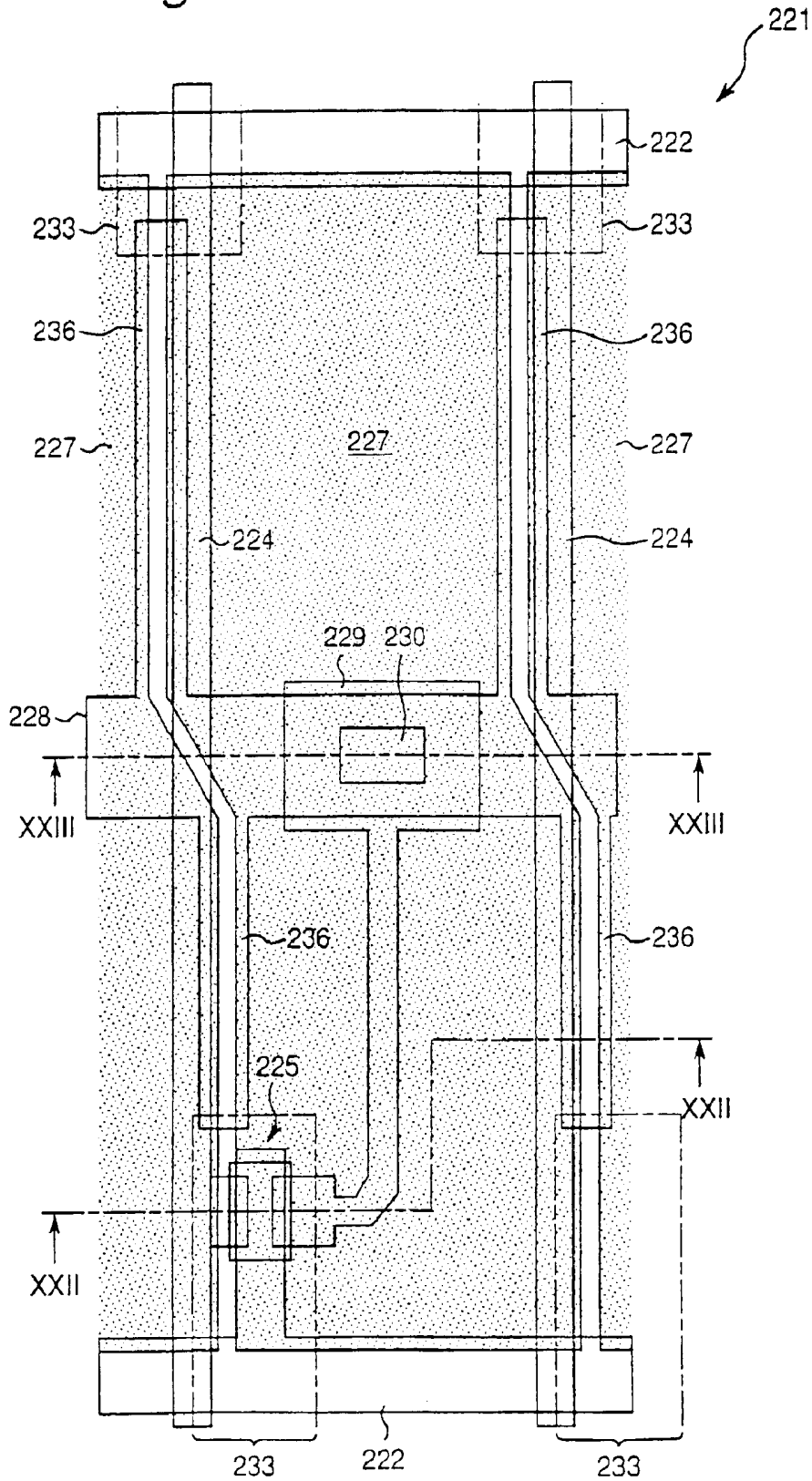

Fig.22

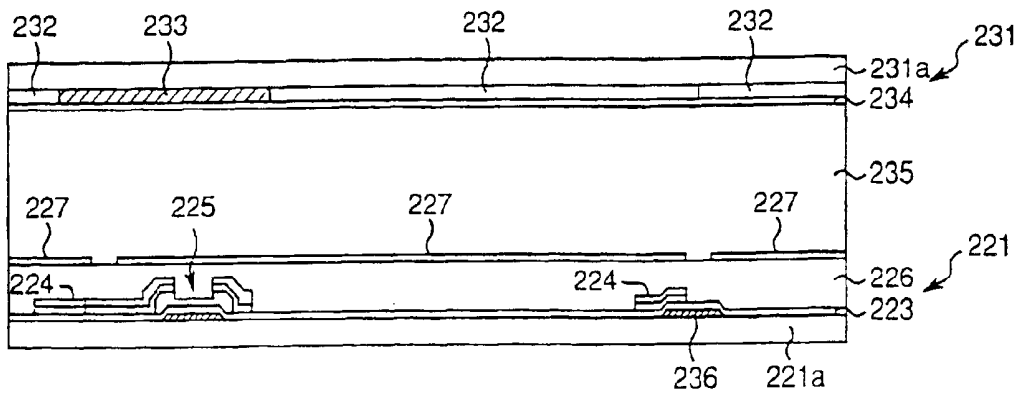

Fig.23

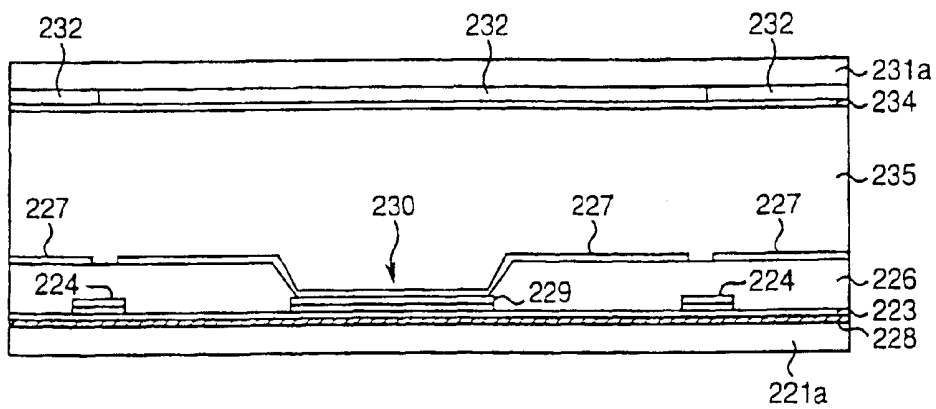

Fig.24 PRIOR ART

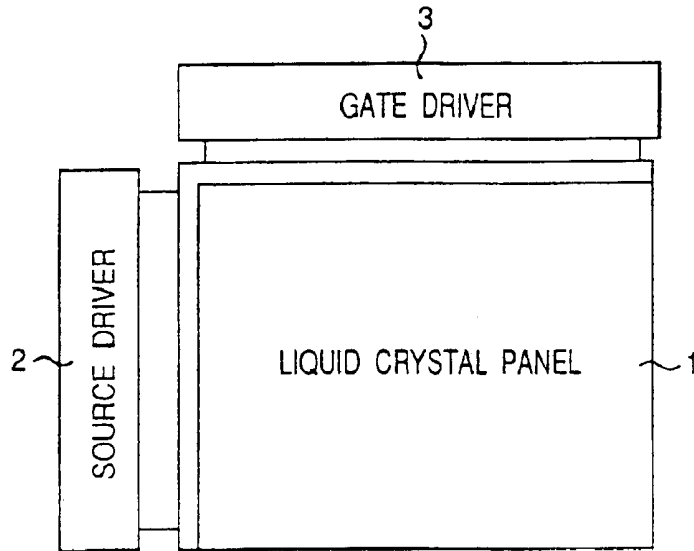

Fig.25 PRIOR ART

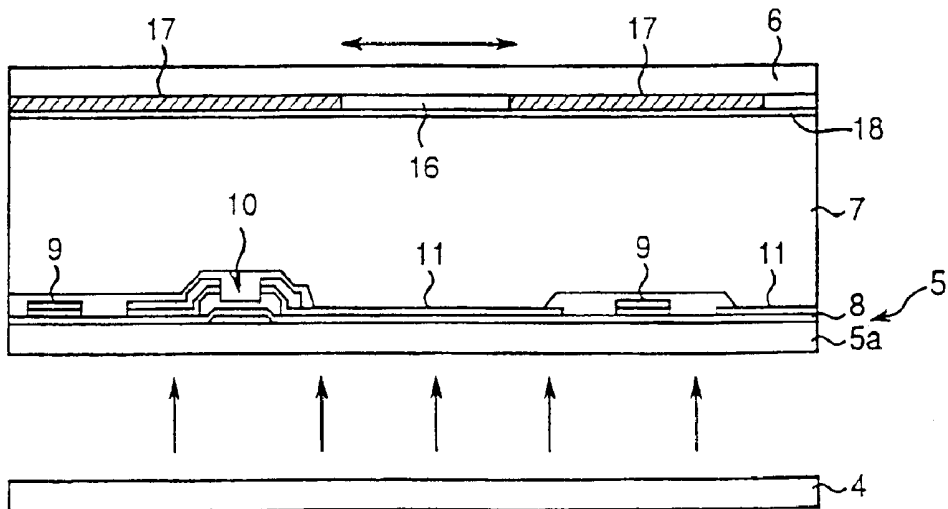

Fig.26 PRIOR ART

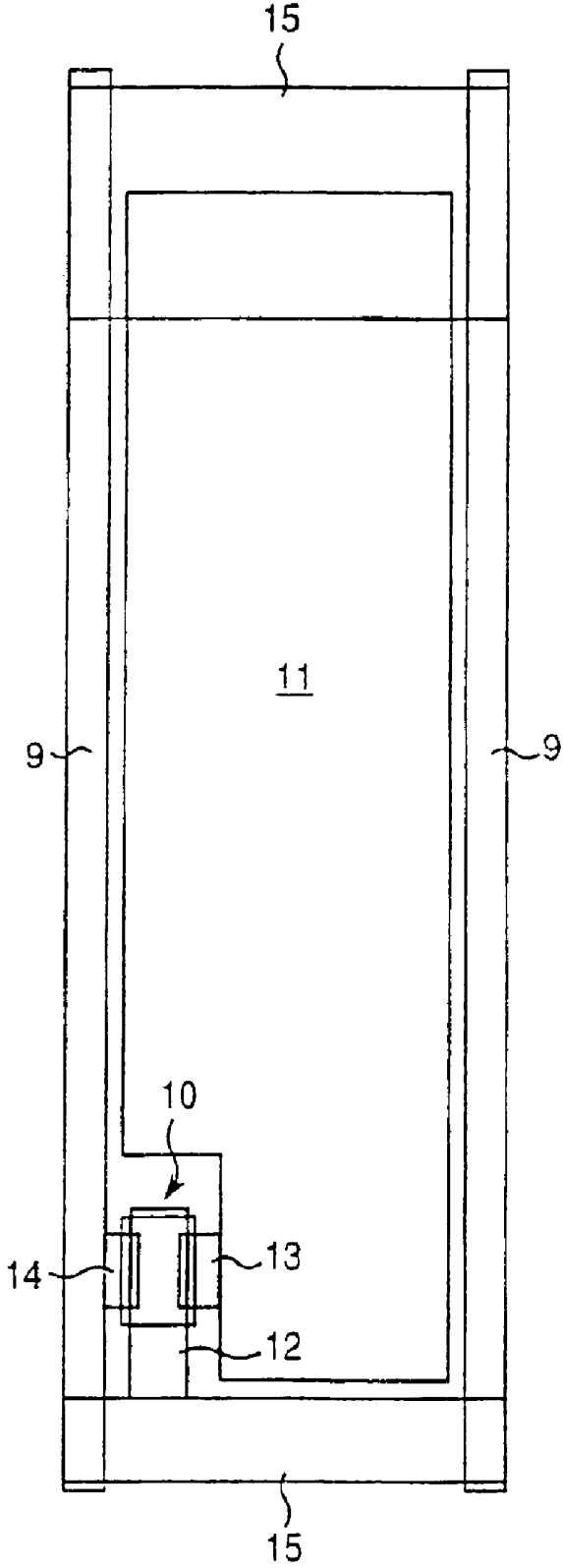

Fig.27 PRIOR ART

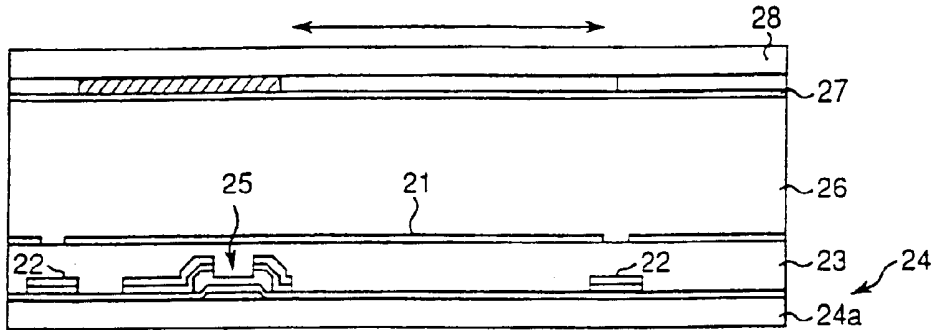

Fig.28 PRIOR ART

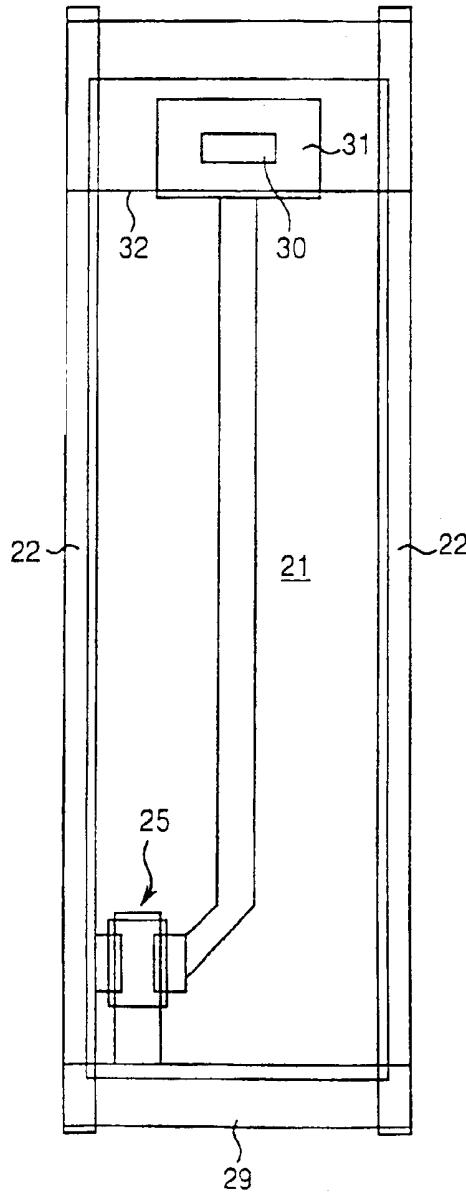

Fig.29 PRIOR ART

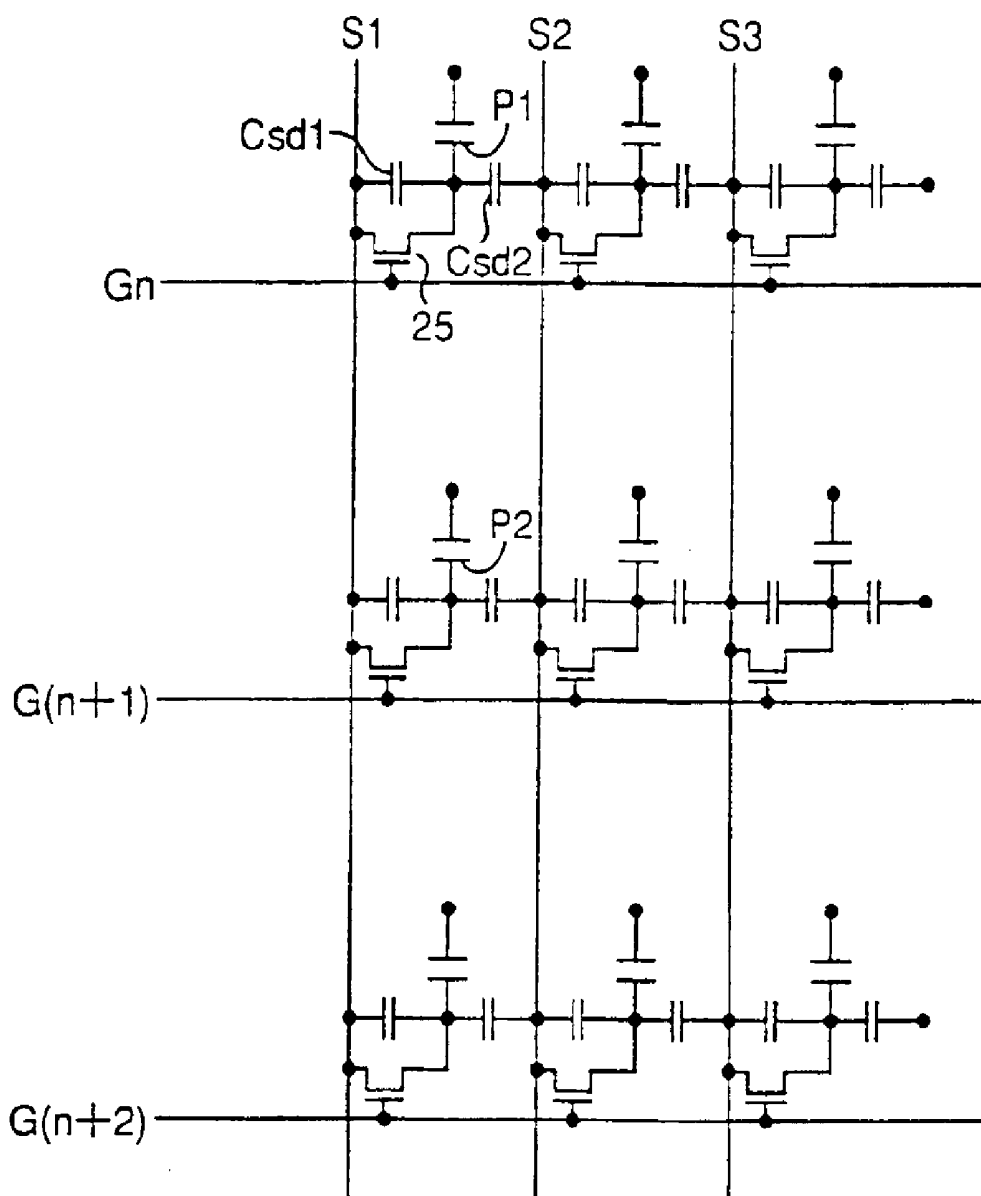

Fig.30 PRIOR ART

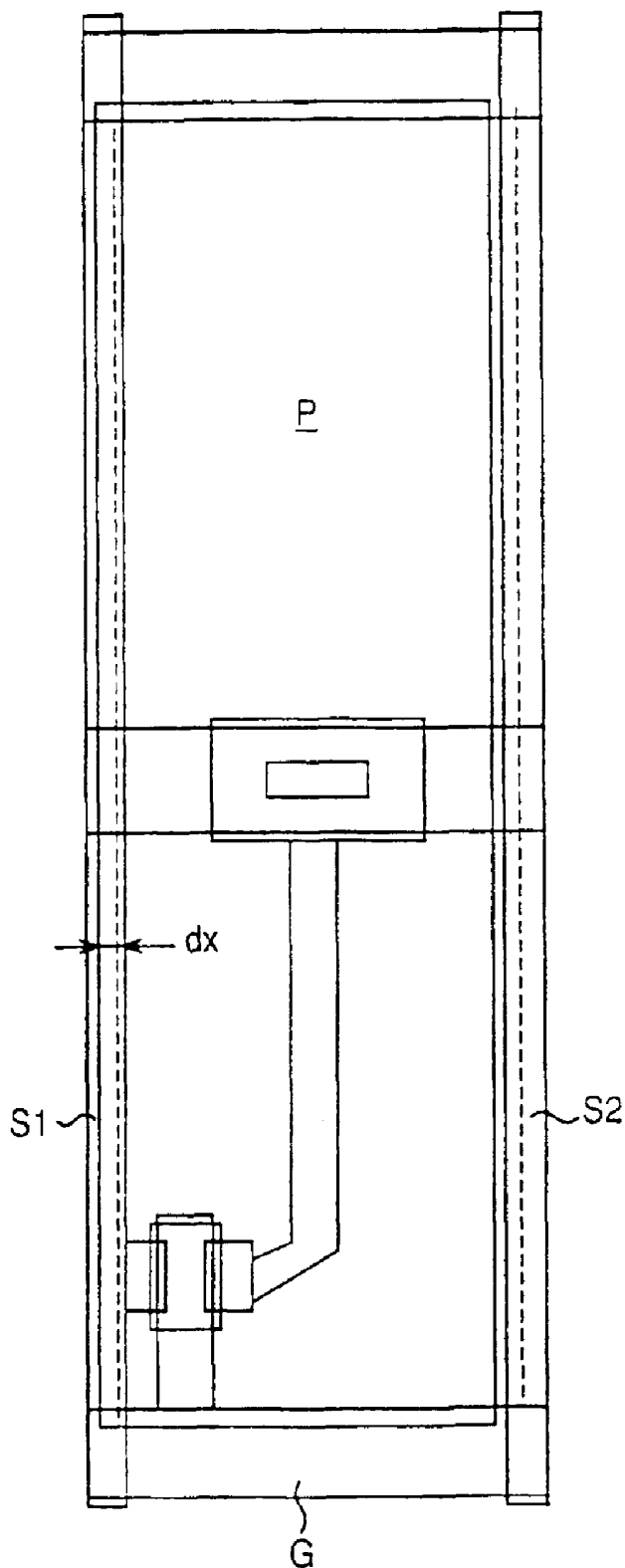

Fig.31

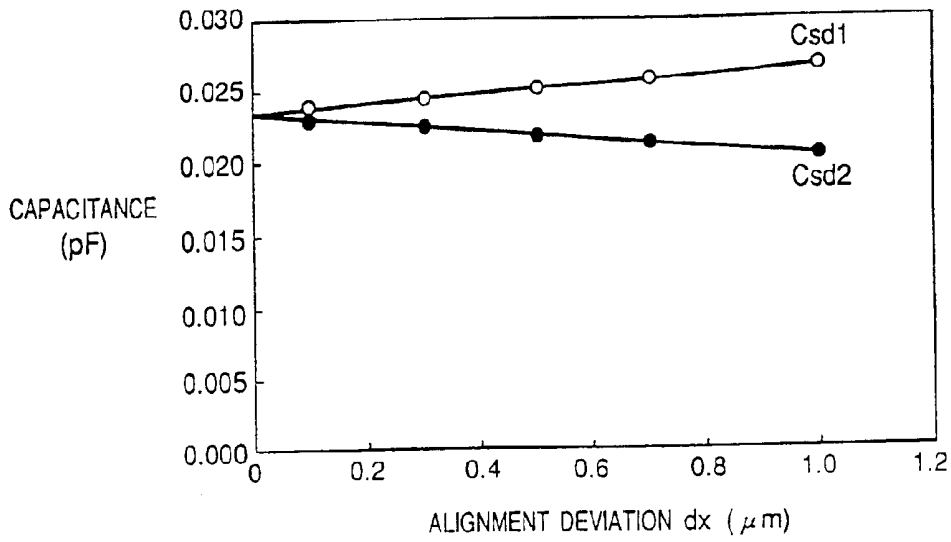
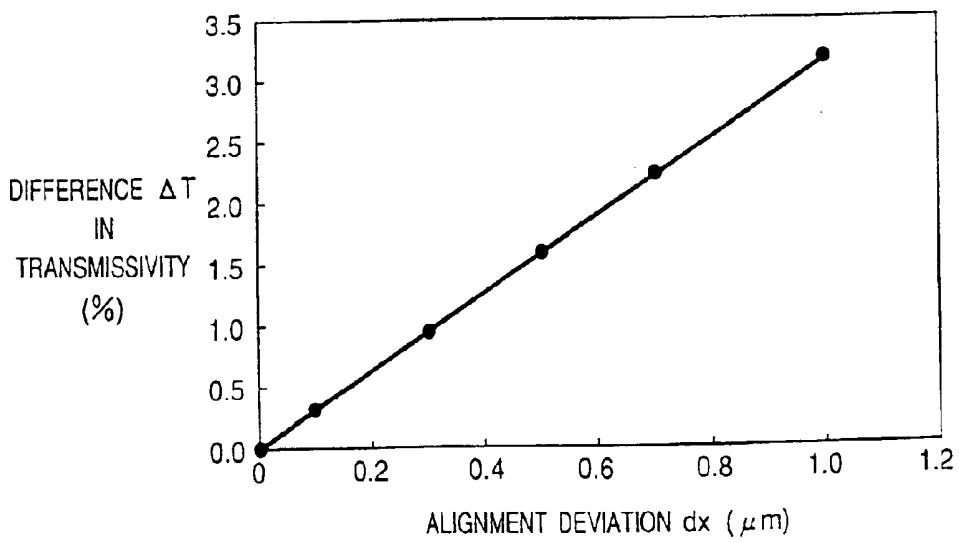

Fig.32



ACTIVE MATRIX TYPE LIQUID CRYSTAL DISPLAY APPARATUS

This application is a divisional of U.S. application Ser. No. 09/821,717, filed Mar. 29, 2001, now U.S. Pat. No. 6,633,360, the teachings of which are incorporated herein by reference in their entirety.

BACKGROUND OF THE INVENTION

The present invention relates to an active matrix type liquid crystal display apparatus for use in a liquid crystal television set, a notebook personal computer, and the like.

FIGS. 24 and 25 are a plan view and a sectional view, respectively, of a conventional active matrix type liquid crystal display apparatus. The active matrix type liquid crystal display apparatus is constituted essentially of a liquid crystal panel 1, a gate driver 2, a source driver 3, and a backlight 4.

The liquid crystal panel 1 has an active matrix board 5, an opposed board 6, a liquid crystal layer 7 sandwiched between the active matrix board 5 and the opposed board 6, and a polarizer (not shown) attached to the outer side of each of the active matrix board 5 and the opposed board 6.

On an insulation substrate 5a of the active matrix board 5, there are provided a plurality of scanning lines (not shown) disposed parallel with one another, a plurality of signal lines 9 parallel with one another and orthogonal to the scanning lines with an insulation film 8 disposed between the signal lines and the scanning lines, thin film transistors (TFTs) 10 disposed in the vicinity of intersections of the scanning lines and the signal lines 9, and a plurality of pixel electrodes 11 disposed in regions surrounded with the scanning lines and the signal lines 9.

FIG. 26 is a plan view showing a one-pixel part of the active matrix board 5. Because the pixel electrode 11 and the signal line 9 are formed in the same layer, the pixel electrode 11 is spaced at a predetermined interval from the signal line 9 to prevent the pixel electrode 11 from contacting the signal line 9. In the TFT 10 which is a three-terminal element, electrical continuity between a drain electrode 13 and a source electrode 14 is controlled by a voltage applied to a gate electrode 12. The gate electrode 12 is connected to a scanning line 15 adjacent thereto. The source electrode 14 is connected to the signal line 9 adjacent thereto. The drain electrode 13 is connected to the pixel electrode 11.

The opposed board 6 is provided with color filters 16 formed in the order of red, green, and blue at positions corresponding to each pixel electrode 11. A black matrix 17 is formed between the adjacent color filters 16 and 16. The black matrix 17 serves as a light shield film for preventing leak of light from the gap between the pixel electrode 11 and the scanning line 15 as well as the signal line 9. An opposed electrode 18 made of a transparent conductive material is formed on a layer of the black matrix 17 and the color filters 16. The gate driver 2 and the source driver 3 are connected to terminals of the scanning lines 15 and those of the signal lines 9, respectively, disposed on the periphery of the liquid crystal panel 1.

The method of driving the active matrix type liquid crystal display apparatus having the construction will be described below.

When writing to an array of pixels of an nth row, an ON-signal (electric potential V_{gh} at which the TFT 10 is turned on) is input to a scanning line 15n of the nth row from the gate driver 2. At this time, an OFF-signal (electric

potential V_{g1} at which the TFT 10 is turned off) is input to scanning lines other than the scanning line 15n. Thus, only the TFTs 10 of the nth row are turned on. On the other hand, source signals having voltages to be applied to the pixels (pixel electrodes 11 and liquid crystal layer 7) of the nth row are supplied to each signal line 9 from the source driver 3.

Upon completion of write for the array of the pixels of the nth row terminates, the OFF-signal is input to the scanning line 15n, whereas the ON-signal is input to the next scanning line 15(n+1). All pixels are charged with voltages corresponding to data by repeating the operation. The transmissivity of the liquid crystal layer 7 disposed between the pixel electrode 11 and the opposed electrode 18 changes depending to a voltage applied across the pixel electrode 11 and the opposed electrode 18, and light emitted from the backlight 4 is therefore adjusted. As a result, images are displayed on the active matrix type liquid crystal display apparatus.

There is proposed a construction in which pixel electrodes are provided on an interlaminar insulation film so that the pixel electrodes and the signal line are formed as different layers and that the pixel electrodes overlap the signal lines (disclosed in Japanese Patent Application Laid-Open No. 63-279228). FIG. 27 is a sectional view showing a one-pixel part of an active matrix type liquid crystal display apparatus having the above-mentioned construction in which pixel electrodes overlap signal lines. FIG. 28 is a plan view of an active matrix board 24 shown in FIG. 27. In the construction, pixel electrodes 21 and signal lines 22 are formed as separate layers, and the pixel electrodes 21 are overlaid on the signal lines 22 through an interlaminar insulation film 23. Thus, it is possible to eliminate the gaps between the pixel electrodes 21 and the adjacent signal lines 22. Thus, it is possible to enlarge the area of the pixel electrodes 21 (aperture ratio) and thus reduce the power consumption of the active matrix type liquid crystal display apparatus. In FIGS. 27 and 28, reference numeral 24a denotes an insulation substrate, 25 denotes a TFT, 26 denotes a liquid crystal layer, 27 denotes an opposed electrode, 28 denotes an opposed board, 29 denotes a scanning line, 30 denotes a contact hole, 31 denotes an auxiliary capacitor electrode, and 32 denotes an auxiliary capacitor line.

However, in comparison with the construction shown in FIG. 26 in which the pixel electrode 11 is spaced at a predetermined interval from the signal line 9, the construction in which the pixel electrodes 21 overlap the signal lines 22 invites an increased capacitance C_{sd} between the pixel electrode 21 and the signal line 22. With the increase of the capacitance C_{sd} , the source signal causes a pixel electric potential to change easily. Eventually, there will occur display characteristic deterioration called shadowing phenomenon.

The mechanism of the shadowing phenomenon will be described below by using an equivalent circuit of the active matrix board 24 shown in FIG. 29. When a TFT 25 is turned on as a result of input of an ON-signal V_{gh} to a scanning line G_n , a pixel electrode P1 is supplied with a voltage V_{s1} from a signal line S1.

Next, when the TFT 25 is turned off as a result of input of an OFF-signal V_{g1} to the scanning line G_n , a voltage V_{s1}' corresponding to data to be written to a pixel electrode P2 of a next stage is supplied to the signal line S1. At this time, the voltage of the pixel electrode P1 is influenced by the voltage V_{s1}' of the signal line S1 through the capacitance C_{sd1} . Supposing that the voltage of the pixel electrode P1 at that time is V_{p1} , the voltage V_{p1} is expressed as follows:

$$Vp1=Vs1-(Csd1(Vs1-Vs1')+Csd2(Vs2-Vs2'))/(Cp+Csd1+Csd2) \quad (1)$$

where Cp is a capacitance of the pixel electrode (Cp=liquid crystal capacitance, Cle+auxiliary electrode capacitance, Ccs), Csd1 is a capacitance between the signal line S1 and the pixel electrode P1, Csd2 is a capacitance between a signal line S2 and the pixel electrode P1, Vs1 and Vs2 are voltages of the signal lines S1 and S2, respectively, in the case where the scanning line Gn of an nth row is in an ON-state, and Vs1' and Vs2' are voltages of the signal lines S1 and S2, respectively, in the case where a scanning line G(n+1) of an (n+1)th row is in an ON-state.

In a gate line inversion driving method (namely, "1H inversion driving") which is a conventional method of driving the active matrix type liquid crystal display apparatus, the polarity of the source signal is inverted every line of gates. Supposing that adjacent gradations are the same,

$$Vs=Vs1=Vs2, Vs'=Vs1'=Vs2' \quad (2)$$

Therefore, from the equations (1) and (2),

$$Vp1=Vs-(Csd1+Csd2)/(Cp+Csd1+Csd2) \cdot (Vs-Vs') \quad (3)$$

As is obvious from the above, in the 1H inversion driving, the amount of change of the pixel electric potential is proportional to (Csd1+Csd2). Therefore, with the increase of the capacitance Csd between the signal line S and the pixel electrode P, the shadowing phenomenon appears conspicuously.

A dot inversion driving method has been proposed as a driving method suppressing the change of the pixel electric potential due to the capacitance Csd between the signal line S and the pixel electrode P. In the dot inversion driving, the polarity of the source signal is inverted not only every line of the gates, but also every line of sources.

Supposing that adjacent gradations are the same in the dot inversion driving,

$$Vs=Vs1=-Vs2, Vs'=Vs1'=-Vs2' \quad (4)$$

From the equations (1) and (4),

$$Vp1=Vs-(Csd1-Csd2)/(Cp+Csd1+Csd2) \cdot (Vs-Vs') \quad (5)$$

From the above, in the dot inversion driving, the variation of the pixel electric potential is proportional to the difference between the capacitance Csd1 and the capacitance Csd2. Therefore, the dot inversion driving is much superior to the 1H inversion drive in suppressing the occurrence of the shadowing phenomenon. Thus, the dot inversion driving can improve the image quality of the liquid crystal display apparatus. In particular, by reducing the difference between the capacitances Csd1 and Csd2 in connection to the pixels adjoining in the direction in which the scanning line 29 extends, it is possible to suppress the occurrence of the shadowing phenomenon to a great extent.

However, the following new problem occurs. In general, in producing a liquid crystal display apparatuses, a photolithographic process is performed block by block. Thus, an alignment deviation occurs from block to block. This leads to the variation in the amount of overlapping between the pixel electrode P and the signal line S and hence the variation in the capacitance Csd between the signal line S and the pixel electrode P. In the case where the dot inversion driving is adopted, the pixel electric potential is liable to change due to the variation in the capacitance Csd. This results in difference of transmissivity among the blocks.

For example, referring to FIG. 30, let it be supposed that an alignment deviation dx has occurred in the photolithographic process of the pixel electrodes P. In this case, there is an increase in the amount of overlapping between the pixel electrode P and the signal line S1. Thus, there is an increase in the capacitance Csd1 between the signal line S1 and the pixel electrode P, whereas there is a decrease in the capacitance Csd2 between the signal line S2 and the pixel electrode P. FIG. 31 shows the relationship between the alignment deviation dx in the photolithographic process and the capacitances Csd1, Csd2. FIG. 31 indicates that with the increase of the alignment deviation dx, the difference between the capacitance Csd1 and the capacitance Csd2 becomes big, and the amount of variation of the pixel electric potential increases.

In the ordinary conventional photolithographic process, the surface of the active matrix board is exposed in blocks. This is the reason why, if a deviation dx occurs in the alignment, the amount of overlap of the pixel electrode on the signal line differs from block to block and the transmissivity differs among the blocks of the active matrix type liquid crystal display apparatus. FIG. 32 shows the relationship between the alignment deviation dx and the difference ΔT in transmissivity between a block having the alignment deviation dx and a block having no alignment deviation.

As is obvious, if the active matrix type liquid crystal display apparatus in which the pixel electrodes overlap the signal lines is driven by the dot inversion driving method, the amount of change in pixel electric potential caused by the coupling capacitances Csd really decreases, but differs largely among the photo-blocks. Consequently, there rises a big difference in the transmissivity among the blocks, leading to a problem called "block separation". As the size of the active matrix type liquid crystal display apparatus becomes larger, the number of blocks tends to increase more and more in the photolithographic process. Thus, there is a growing demand for suppression of the occurrence of the "block separation" caused by the coupling capacitance Csd.

SUMMARY OF THE INVENTION

Therefore, it is an object of the present invention to provide an active matrix type liquid crystal display apparatus capable of preventing the image quality from deterioration due to a coupling capacitance between a signal line and a pixel electrode as well as suppressing the "block separation" due to variations in the coupling capacitance.

In order to accomplish the above object, there is provided, according to an aspect of the present invention, an active matrix type liquid crystal display apparatus comprising:

an insulation substrate;

scanning lines formed on the insulation substrate;

signal lines extending in a direction intersecting a direction in which the scanning lines extend;

switching devices provided in the vicinity of each intersection of the scanning and signal lines such that the switching devices are arrayed in a matrix form;

an interlaminar insulation film disposed on or above the scanning lines, the signal lines, and the switching devices; and

pixel electrodes formed on the interlaminar insulation film and arranged in a matrix form, each electrode being connected to an output terminal of an associated switching device,

wherein only a part of each of opposite side portions of one pixel electrode widthwise covers two signal lines extending adjacent to the pixel electrode.

With the above arrangement, the two signal lines adjacent to one pixel electrode are widthwise covered only by a part of each side portion extending along the signal lines of the pixel electrode. Accordingly, there is no great change in the difference between a first capacitance between the pixel electrode and one of the two signal lines and a second capacitance between the pixel electrode and the other signal line even though there is a misalignment between layers. As a result, the so-called "block separation" is suppressed, which would otherwise occur in a production process step in which photolithography is performed block by block.

In one embodiment, each pixel electrode covers the associated switching device. In the construction, it is possible to form the pixel electrode almost rectangularly, which leads to an increase in the area of the pixel electrode. Thus, the power consumption can be suppressed.

In one embodiment, each signal line is bent twice between two adjacent scanning lines such that two generally parallel but longitudinally displaced parts are formed, and these two parts are covered by opposed side portions of two adjacent pixel electrodes.

With this arrangement, the pixel electrodes can be formed in a rectangular shape. Thus, it is easy to form a color filter and/or a black matrix to be disposed on an opposed board confronting the insulation substrate, wherein the color filter may have a configuration similar to that of the pixel electrode and the black matrix may be formed so as to span a gap between two adjacent pixel electrodes.

In another embodiment, the parts of the pixel electrode covering the two signal lines adjacent to the pixel electrode are parts that overhang from side edges of the pixel electrode.

With the arrangement, the signal lines can be straight, and not bent, resulting in the reduced length of the signal line. This eventually prevents the delay of a source signal and/or the breaking or discontinuity of the signal line in a large active matrix type liquid crystal display apparatus having a size more than 15 inches.

Both side edges of each pixel electrode may be bent twice such that the overhanging parts are diagonally formed on the respective sides of the pixel electrode and these overhanging parts cover the two signal lines adjacent to the pixel electrode.

Each switching device may be disposed in the vicinity of a gap between two adjacent pixel electrodes. The gap between the two adjacent pixel electrodes and the vicinity thereof are regions that essentially should be shielded from light. Accordingly, it is unnecessary to dispose a black matrix dedicated to the switching elements. Thus, it is possible to prevent the increase of the area of the black matrix. Therefore, it is possible to obtain a large aperture ratio.

In one embodiment, the active matrix type liquid crystal display apparatus of this invention comprises an opposed board having a black matrix, and the black matrix is located between two adjacent pixel electrodes in such a manner that the black matrix overlaps each one of these pixel electrodes by at least an amount corresponding to an alignment margin of the opposed board relative to the insulation board.

In this case, positions of both side edges of the black matrix to be disposed on the opposed board are set taking the alignment margin between the opposed board and the insulation substrate into consideration. Accordingly, even though there is a misalignment between both substrates, the gap between the adjacent pixel electrodes is surely shielded from light and thus the occurrence of the so-called "block separation" is suppressed to a higher extent.

In a location where the signal line is covered by the pixel electrode, an edge of the black matrix may be disposed along a center line of the pixel electrode or on an inner side of the pixel electrode than the center line.

A light shield film may be provided on the insulation substrate in such a manner that the light shield film spans a gap between the adjacent pixel electrodes.

Generally, the accuracy of alignment between the insulation substrate formed with the pixel electrodes and the opposed board confronting the insulation substrate is about $\pm 5 \mu\text{m}$, whereas the accuracy of alignment between layers on the insulation substrate is less than $\pm 1 \mu\text{m}$. Thus, the width of the light shield film is allowed to be smaller than that of the black matrix which would be disposed on the opposed board so as to span the gap between the adjacent pixel electrodes if no such light shield film was provided on the insulation substrate. In addition, it is not necessary any more to dispose on the opposed board a black matrix spanning the gap between the pixel electrodes. Consequently, the aperture ratio will be increased. Furthermore, because the total area of the black matrix disposed on the opposed board is reduced, it is possible to widen the bonding margin between the insulation substrate and the opposed board.

According to another aspect of the present invention, there is provided an active matrix type liquid crystal display apparatus comprising:

- an insulation substrate;
- scanning lines formed on the insulation substrate,
- auxiliary capacitor lines arranged parallel to the scanning lines;

- signal lines extending in a direction intersecting a direction in which the scanning lines extend;

- switching devices provided in the vicinity of each intersection of the scanning and signal lines such that the switching devices are arrayed in a matrix form;

- an interlaminar insulation film disposed on or above the scanning lines, auxiliary capacitor lines, the signal lines, and the switching devices; and

- pixel electrodes formed on the interlaminar insulation film and arranged in a matrix form, each electrode being connected to an output terminal of the associated switching device,

- wherein both side edges of each pixel electrode are bent twice such that the overhanging parts are formed on the respective sides of the pixel electrode and these overhanging parts cover two signal lines adjacent to the pixel electrode, and

- wherein the auxiliary capacitor line underlies a portion between the two bents of each side edge of the pixel electrode.

With the above arrangement, the signal lines adjacent to the pixel electrode are widthwise covered by the respective overhanging parts of the pixel electrode. Therefore, a difference between a first capacitance between the pixel electrode and one of the two adjacent signal lines and a second capacitance between the pixel electrode and the other adjacent signal line is reduced. Thus, the shadowing phenomenon can be considerably suppressed by performing the dot inversion driving scheme.

The auxiliary capacitor line underlies the portion (referred to also as a "bent portion") between the two bents of each side edge of the pixel electrode. Thus, the capacitance between the signal line and the pixel electrode at its bent portion is reduced. Consequently, the change in the coupling capacitance between the pixel electrode at the bent portion

and the signal line due to a misalignment between layers is considerably reduced. Accordingly, it is possible to suppress the occurrence of the "block separation", which otherwise would occur in performing a lithographic process from block to block.

The auxiliary capacitor line may include electrode portions that extend toward a portion between the two bents of each side edge of the pixel electrode such that the electrode portions underlie the portions between the two bents of each side edge of the pixel electrode. In this case, the auxiliary capacitor line proper, namely a portion running parallel to the scanning lines of the auxiliary capacitor line can be located in any desired positions relative to the longitudinal direction of the pixel electrode.

A light shield film may be provided on the insulation substrate in such a manner that the light shield film spans a gap between the adjacent pixel electrodes.

In one embodiment, the light shield film is electrically connected to either the auxiliary capacitor line or the scanning line. In this case, owing to the field shield effect of the light shield film, a part of a line of electric force emitted from the signal line terminates at the auxiliary capacitor line or the scanning line. Thus, a first capacitance between the pixel electrode and one of the two adjacent signal lines and a second capacitance between the pixel electrode and the other adjacent signal line are reduced. As a result, the shadowing phenomenon due to the difference between the first and second capacitances is further suppressed, and the "block separation" is well prevented from occurrence.

Instead of bending both side edges of each pixel electrode, each signal line may be bent. In this case, the signal line is bent twice between two adjacent scanning lines such that two generally parallel but longitudinally displaced parts are formed, and these two parts are covered by opposed side portions of two adjacent pixel electrodes, and the auxiliary capacitor line is located in a position corresponding to the portion between the two bents of the signal line. Similar effects can be achieved also in this case.

Other objects, features and advantages of the present invention will be obvious from the following description.

BRIEF DESCRIPTION OF THE DRAWINGS

The present invention will become more fully understood from the detailed description given hereinbelow and the accompanying drawings which are given by way of illustration only, and thus are not limitative of the present invention, and therein:

FIG. 1 is a plan view of an active matrix board in a first embodiment of the active matrix type liquid crystal display apparatus according to the present invention;

FIG. 2 is a sectional view taken along line II—II of FIG. 1;

FIG. 3 shows deviations in photo-alignment and amounts of change of coupling capacitances;

FIG. 4 is a plan view of an active matrix board in a second embodiment of the present invention;

FIG. 5 is a sectional view taken along line V—V of FIG. 4;

FIG. 6 is a plan view of an active matrix board in a third embodiment of the present invention;

FIG. 7 is a sectional view taken along line VII—VII of FIG. 6;

FIG. 8 is a plan view of a modification of the active matrix board shown in FIG. 6;

FIG. 9 is a sectional view taken along line IX—IX of FIG. 8;

FIG. 10 is a plan view of an active matrix board in a fourth embodiment of the present invention;

FIG. 11 is a sectional view taken along line XI—XI of FIG. 10;

FIG. 12 is a plan view of an active matrix board in a fifth embodiment of the present invention;

FIG. 13 is a sectional view taken along line XIII—XIII of FIG. 12;

FIG. 14 is a sectional view taken along line XIV—XIV of FIG. 12;

FIG. 15 is a plan view of an active matrix board in a sixth embodiment of the present invention;

FIG. 16 is a sectional view taken along line XVI—XVI of FIG. 15;

FIG. 17 is a sectional view taken along line XVII—XVII of FIG. 15;

FIG. 18 is a plan view of an active matrix board in a seventh embodiment of the present invention;

FIG. 19 is a sectional view taken along line XIX—XIX of FIG. 18;

FIG. 20 is a sectional view taken along line XX—XX of FIG. 18;

FIG. 21 is a plan view of an active matrix board in an eighth embodiment of the present invention;

FIG. 22 is a sectional view taken along line XXII—XXII of FIG. 21;

FIG. 23 is a sectional view taken along line XXIII—XXIII of FIG. 21;

FIG. 24 is a plan view of a conventional active matrix type liquid crystal display apparatus;

FIG. 25 is a sectional view showing a one-pixel part of the active matrix type liquid crystal display apparatus shown in FIG. 24;

FIG. 26 is a plan view showing the one-pixel part of the active matrix type liquid crystal display apparatus shown in FIG. 24;

FIG. 27 is a sectional view of a conventional active matrix type liquid crystal display apparatus in which pixel electrodes overlap signal lines;

FIG. 28 is a plan view of an active matrix board shown in FIG. 27;

FIG. 29 shows an equivalent circuit of the active matrix board shown in FIG. 28;

FIG. 30 is an explanatory view showing an alignment deviation or misalignment of a pixel electrode;

FIG. 31 shows the relationship between the alignment deviation of the pixel electrode and the capacitance between the pixel electrode and an adjacent signal line; and

FIG. 32 shows the relationship between an alignment deviation and the difference in transmissivity between a block having the alignment deviation and a block having no alignment deviation.

DETAILED DESCRIPTION OF THE PREFERRED EMBODIMENTS

<First Embodiment>

FIG. 1 is a plan view of an active matrix board 51 of an active matrix type liquid crystal display apparatus (hereinafter referred to as simply an LCD apparatus) according to the first embodiment of the present invention. FIG. 2 is a sectional view taken along line II—II of FIG. 1.

The active matrix board **51** has the following construction. As shown in FIGS. **1** and **2**, a plurality (only two are shown) of gate lines (scanning lines) **52** made of metal such as Al, Ta are disposed parallel with one another on an insulation substrate **51a** made of glass. The film thickness of the gate line **52** is in the range of 2000 Å–5000 Å. Above the gate lines **52** a plurality (only two are shown) of source lines (signal lines) **54** made of metal such as Al, Ta are disposed perpendicular to the gate lines **52**, with a gate insulation film **53** made of SiNx or the like disposed between the gate lines **52** and the source lines **54**. The film thickness of the gate insulation film **53** is in the range of 2000 Å–4000 Å. The dielectric constant of the gate insulation film **53** is three to eight. The film thickness of the source line **54** is in the range of 1000 Å–5000 Å.

Amorphous silicon TFTs **55** (only one of which is shown) are disposed in the neighborhood of the intersections of the gate lines **52** and the source lines **54**. Each amorphous silicon TFT **55** is composed by a gate electrode **56**, the gate insulation film **53**, an amorphous semiconductor layer **57**, an impurity-added semiconductor layer **58**, a source electrode **59**, and a drain electrode **60**. The gate electrode **56** and the gate line **52** are made of the same material. The source electrode **59**, the drain electrode **60**, and the source line **54** are made of the same material. The amorphous semiconductor layer **57** is made of amorphous silicon formed by CVD (chemical vapor deposition). The film thickness of the amorphous semiconductor layer **57** is in the range of 500 Å–2000 Å. The gate electrode **56** is connected to the gate line **52** adjacent thereto. The source electrode **59** is connected to the source line **54** adjacent thereto.

A gate line **52a** at the preceding stage overlaps a pixel electrode **62** at a current stage. On the gate insulation film **53**, the drain electrode **60** extends to a position of an overlapping part of the gate line **52a** to form an auxiliary capacitor electrode **64** at an end of the drain electrode **60**. An interlaminar insulation film **61** is made of an organic material or an inorganic material. The film thickness of the interlaminar insulation film **61** is 1 μm to 4 μm. The dielectric constant of the interlaminar insulation film **61** is two to four. A contact hole **65** is formed in the interlaminar insulation film **61** at the position of the auxiliary capacitor electrode **64**. The drain electrode **60** is connected to the pixel electrode **62** through the auxiliary capacitor electrode **64** and the contact hole **65**. That is, the gate line **52a** at the preceding stage is used as the auxiliary capacitor line for the pixel of the current stage.

In the embodiment, the pixel electrode **62** has a rectangular overhanging part **62a** at a TFT **55**-side end portion of one longitudinal side. The overhanging part **62a** projects widthwise by a predetermined amount from an edge of the one longitudinal side of the pixel electrode **62**. The pixel electrode **62** also has a similar rectangular overhanging part **62b** at an end portion opposite from the TFT **55** of the other longitudinal side. The overhanging part **62b** projects widthwise by a predetermined amount from an edge of the other longitudinal side of the pixel electrode **62**. The projection amount of the overhanging part **62a** and that of the overhanging part **62b** are so set that the overhanging parts **62a** and **62b** overlap source lines **54a** and **54b** disposed on opposite sides of the pixel electrode **62**, respectively. The length of the overhanging part **62a** is equal to that of the overhanging part **62b**.

The LCD apparatus has an opposed board **66** with the following construction. That is, as shown in FIG. **2**, color filters **67** are formed on an insulation substrate **66a** in the order of colors of red, green, and blue at a position corre-

sponding to each pixel electrode **62**. A black matrix **68** is formed between the color filters **67** and **67**. The black matrix **68** serves as a patterned light shield film for preventing leak of light from the gaps between the source lines **54** and the pixel electrodes **62** as well as between the adjacent pixel electrodes. An opposed electrode **69** made of a transparent conductive material is formed over the color filters **67** and the black matrix **68**.

The active matrix board **51** and the opposed board **66** are spaced at a predetermined interval, with the pixel electrodes **62** and the opposed electrode **69** opposed to each other. Then, a liquid crystal layer **70** is sandwiched between the active matrix board **51** and the opposed board **66**. A sealer is applied to the resulting laminate to complete the LCD apparatus.

As described above, in the first embodiment, the rectangular overhanging parts **62a** and **62b** are formed at the end portions of both sides of the pixel electrode **62**. The overhang amount of the overhanging part **62a** and that of the overhanging part **62b** are so set that the overhanging parts **62a** and **62b** overlap the source lines **54a** and **54b** adjacent to the pixel electrode **62**, respectively. The length of the overhanging part **62a** is equal to that of the overhanging part **62b**. Also, the length of each of the overhanging parts **62a** and **62b** is set such that capacitances generated between the pixel electrode **62** and each of the source lines **54a**, **54b** in a region not covered by the pixel electrode **62** are small enough to be ignored.

In the above arrangement, the source lines **54a** and **54b** are mostly or entirely covered with the overhanging parts **62a** and **62b**, respectively. Therefore, even though some alignment deviation occurs between blocks during the photolithographic process, the capacitance Csd1 between the pixel electrode **62** and the source line **54a** and the capacitance Csd2 between the pixel electrode **62** and the source line **54b** hardly change. Thus, the difference in transmissivity between the blocks becomes smaller.

From the above reason, it follows that the value of (Csd1–Csd2) of the equation (5) is almost constant in all blocks. Thus, it is possible to prevent the “block separation” from occurring. FIG. **3** shows deviations in photo-alignment and amounts of change of coupling capacitances in the LCD apparatus of the embodiment and the conventional LCD apparatus shown in FIGS. **27** and **28**. As is obvious from FIG. **3**, the amount of change of (Csd1–Csd2) is lowered by adopting the arrangement in which parts **62a** and **62b** of the pixel electrode **62** at both sides overhang the source lines **54a** and **54b**. This is why the “block separation” due to the misalignment is suppressed.

Again, according to the first embodiment, it is possible to suppress the occurrence of the “block separation” which would be caused by the variations in the coupling capacitance Csd between the pixel electrode **62** and the source lines **54a**, **54b**.

<Second Embodiment>

FIG. **4** is a plan view of an active matrix board **71** of an active matrix type LCD apparatus of the second embodiment. FIG. **5** is a sectional view taken along line V—V of FIG. **4**.

Referring to FIGS. **4** and **5**, the active matrix board **71** has an insulation substrate **71a**, gate lines **72**, a gate insulation film **73**, TFTs **75**, an interlaminar insulation film **76**, auxiliary capacitor electrodes **78**, and contact holes **79** which have the same constructions and functions as the insulation substrate **51a**, the gate lines **52**, the gate insulation film **53**, the TFTs **55**, the interlaminar insulation film **61**, the auxiliary capacitor electrodes **64**, and the contact holes **65** of the

active matrix board **51** in the first embodiment shown in FIGS. **1** and **2**. Also, an opposed board **80** of the LCD apparatus of the second embodiment has an insulation substrate **80a**, color filters **81**, a patterned black matrix **82**, and an opposed electrode **83** which are the same constructions and functions as the insulation substrate **66a**, the color filters **67**, the black matrix **68**, and the opposed electrode **69** of the opposed board **66** of the first embodiment. Also, a liquid crystal layer **84** in the second embodiment has the same construction and function as the liquid crystal layer **70** in the first embodiment.

Pixel electrodes **77** in the second embodiment do not have parts jutting out widthwise to overhang the source lines **74**, **74'**, but are rectangular. Instead, each source line **74**, **74'** is bent twice in the vicinity of a position where the pixel electrode **77** is bisected relative to the longitudinal direction into a TFT-side part and a counter-TFT-side part that is a part of the side opposite from the TFT **55**. That is, each source line **74**, **74'** is configured to have approximately parallel but longitudinally displaced straight portions and a transition portion (referred to as "bent portion") connecting the neighboring straight portions. The TFT-side part of each pixel electrode **77** is laid over the corresponding part of the source line **74** positioned on one side (e.g., the right-hand side) of the pixel electrode **77**, while the counter-TFT-side part of the pixel electrode **77** is laid over the corresponding part of the source line **74'** positioned on the other side (e.g., the left-hand side) of the pixel electrode **77**, with the interlaminar insulation film **76** interposed between the source lines and the pixel electrodes.

In the above arrangement, the source lines **74** and **74'** located on opposite sides of one pixel electrode **77** are covered by respective lateral zones of the TFT-side and counter-TFT-side halves of the pixel electrode. Therefore, even though a misalignment occurs between blocks to some degree during the photolithographic process, the capacitances Csd1 and Csd2 hardly change. Thus, the difference in transmissivity among the blocks becomes smaller.

Furthermore, according to the second embodiment, the pixel electrode **77** is formed rectangularly as in the conventional active matrix type LCD apparatus shown in FIGS. **26** and **27**. Therefore, the color filter **81** and the black matrix **82** can be easily formed.

<Third Embodiment>

FIG. **6** is a plan view of an active matrix board **91** in the third embodiment of the present invention. FIG. **7** is a sectional view taken along line VII—VII of FIG. **6**.

Referring to FIGS. **6** and **7**, the active matrix board **91** has an insulation substrate **91a**, gate lines **92**, a gate insulation film **93**, source lines **94**, **94'**, TFTs **95**, an interlaminar insulation film **96**, auxiliary capacitor electrodes **98**, and contact holes **99** which have the same constructions and functions as the insulation substrate **51a**, the gate lines **52**, the gate insulation film **53**, source lines **54**, **54'**, the TFTs **55**, the interlaminar insulation film **61**, the auxiliary capacitor electrodes **64**, and the contact holes **65** of the active matrix board **51** in the first embodiment shown in FIGS. **1** and **2**. Also, an opposed board **100** of the LCD apparatus of the second embodiment has an insulation substrate **100a**, color filters **101**, a patterned black matrix **102**, and an opposed electrode **103** which are the same constructions and functions as the insulation substrate **66a**, the color filters **67**, the black matrix **68**, and the opposed electrode **69** of the opposed board **66** of the first embodiment. Also, a liquid crystal layer **104** in the third embodiment has the same construction and function as the liquid crystal layer **70** in the first embodiment.

In the third embodiment, each one of the opposite longitudinal side edges of the pixel electrode **97** is bent twice in the vicinity of a position where the pixel electrode **97** is bisected into a TFT-side part and a counter-TFT-side part in the longitudinal direction in which the source lines **94**, **94'** extend. As a result, the pixel electrode **97** diagonally forms overhanging parts on either side along about half the length of the pixel electrode. The TFT-side overhanging part on one side of the pixel electrode **97** is overlaid on the adjacent source line **94'** through the interlaminar insulation film **96**, while the counter-TFT-side overhanging part on the other side of the pixel electrode **97** is overlaid on the other adjacent source line **94** also through the interlaminar insulation film **96**.

In the above arrangement, the source lines **94** and **94'** located on opposite sides of one pixel electrode **97** are covered by the respective lateral overhanging parts of the pixel electrode. Therefore, even though a misalignment occurs between blocks to some degree during the photolithographic process, the capacitances Csd1 and Csd2 hardly change. Thus, the difference in transmissivity among the blocks becomes smaller.

Further, according to the third embodiment, the lateral overhanging parts of the pixel electrode **97** for covering the source lines **94** have a length almost half the length of pixel electrode **97**, so that each source line is covered almost entirely in the axial direction of the source line by the adjoining overhanging parts. Accordingly, it is possible to suppress the variation of the capacitance Csd between the pixel electrode **97** and the source line **94** to a higher extent in the third embodiment than in the first embodiment in which the source lines **54a** and **54b** are covered with the overhanging parts **62a** and **62b** shorter than the half of the side edge of the pixel electrode **62**, respectively. Thus, it is possible to suppress the occurrence of the "block separation" more.

Further, it is possible to increase the aperture ratio by bending the pixel electrode **97** over the source lines **94** and **94'**. Particularly in a large LCD apparatus having a size of more than 15 inches, delay of a source signal and break or conduction failure of the source line raise a problem. To solve the problem, it is necessary to reduce the wiring or routing length of the source line to a possible shortest length. The source lines **94** and **94'** in the third embodiment are arranged straight. Thus, it is possible to make the length of the source lines **94** and **94'** shorter in the third embodiment than in the second embodiment in which the source line **74** is bent or winding in the neighborhood of each pixel electrode **77**. Therefore, the third embodiment is advantageous in preventing the delay of the source signal and break of the source line.

FIG. **8** is a plan view of a modification of the active matrix board of the third embodiment. FIG. **9** is a sectional view taken along line IV—IV of FIG. **8**.

In the modification, each of overhanging parts **111a** and **111b** of a pixel electrode **111** laterally extends beyond the source line **112** toward an adjacent pixel. This construction allows the pixel electrode **111** to sufficiently overhang the source line **112**. Thus, an alignment margin in the formation of the pixel electrode becomes larger, which contributes to further suppression of the "block separation".

The pixel electrode **111** is connected to a drain electrode **114** of a TFT **113** through a contact hole **115**, and an auxiliary capacitor electrode **116** is connected to the pixel electrode **111** through a contact hole **117**.

<Fourth Embodiment>

FIG. **10** is a plan view of an active matrix board **121** in the fourth embodiment of the present invention. FIG. **11** is a sectional view taken along line XI—XI of FIG. **10**.

Referring to FIGS. 10 and 11, the active matrix board 121 in the fourth embodiment has an insulation substrate 121a, gate lines 122, a gate insulation film 123, source lines 124, TFTs 125, an interlaminar insulation film 126, pixel electrodes 127, auxiliary capacitor electrodes 128, and contact holes 129 which have the same constructions and functions as the insulation substrate 91a, the gate lines 92, the gate insulation film 93, the source lines 94, 94', the TFTs 95, the interlaminar insulation film 96, the pixel electrodes 97, the auxiliary capacitor electrodes 98, and the contact holes 99 of the active matrix board in the third embodiment shown in FIGS. 6 and 7. Also, an opposed board 130 in the fourth embodiment has an insulation substrate 130a and an opposed electrode 133 which are the same constructions and functions as the insulation substrate 100a and the opposed electrode 103 of the opposed board 100 of the third embodiment. Also, a liquid crystal layer 134 in the fourth embodiment has the same construction and function as the liquid crystal layer 107 in the third embodiment.

In the fourth embodiment, as in the modification of the third embodiment, the pixel electrode 127 has overhanging parts which extend beyond the respective source lines 124 toward adjacent pixels, the pixel electrode 127 is connected to a drain electrode 136 of the TFT 125 through a contact hole 137, and the auxiliary capacitor electrode 128 is connected to the pixel electrode 127 through the contact hole 129.

In the fourth embodiment, a light shield film 135 made of the same material as that of the gate lines 122 is disposed in the same layer as the gate lines 122 to optically shield the gap between adjacent pixel electrodes 127 and 127. Thus, it is unnecessary to form the black matrix 132 on the opposed board 130 in such a position that the black matrix 132 confronts the gap between the adjacent pixel electrodes 127 and 127. Thus it is enough to form the black matrix 132 only in positions in which it confronts the TFTs 125.

The accuracy of the alignment between the active matrix board 121 and the opposed board 130 is generally about $\pm 5 \mu\text{m}$, whereas the accuracy of the alignment between the layers of the active matrix board 121 is less than $\pm 1 \mu\text{m}$. Thus, the light shield film 135 of the active matrix board 121 is allowed to be made smaller in width than the black matrix 132 that would be used without the light shield film 135. Also, because provision of the light shield film 135 eliminates the black matrix 132 in the corresponding locations in the opposed board, the area of the color filters 131 is increased, resulting in the improved aperture ratio.

Furthermore, because the area of the black matrix 32 disposed on the opposed board 130 is reduced, it is possible to widen the bonding margin between the active matrix board 121 and the opposed board 130.

In the fourth embodiment, the construction in which the light shield film 135 is provided and the formation of the black matrix 132 is omitted owing to the provision of the light shield film 135 has been applied to the third embodiment. This construction may be applied to the first and second embodiments.

In each of the first to fourth embodiments, the thin film transistor 55, 75, 95, 113, 125 is disposed in the vicinity of a region below the gap between the adjacent pixel electrodes 62 and 62, 77 and 77, 97 and 97, 111 and 111, 127 and 127 respectively through the interlaminar insulation film 61, 76, 96, 126. In other words, the thin film transistor 55, 75, 95, 113, 125 is disposed in the vicinity of a region corresponding to the location in which the black matrix 68, 82, 102, 132 is to be disposed in any case. Therefore, it is unnecessary to dispose a black matrix for specific use for the thin film

transistors 55, 75, 95, 113, and 125. Thus, the area of the black matrix 68, 82, 102, and 132 is prevented from being increased. Therefore, it is possible to obtain a large aperture ratio.

In each of the above embodiments, the region in which the black matrix 68, 82, 102, and 132 is formed is set as follows. That is, the black matrix is formed on the opposed board such that the black matrix is opposed to the gap between two adjacent pixel electrodes. One side edge of the black matrix opposed to a source line-covering pixel electrode includes the longitudinal center line of the covered source line (in cases shown in FIGS. 4, 6, 8, and 10) or is located at the inner side (see FIG. 1) of the pixel electrode with respect to the center line of the source line. On the other hand, the other side edge of the black matrix is spaced by more than an alignment margin between the opposed board and the active matrix board from the side edge of the source line opposite from the above pixel electrode.

In this manner, the positions of both side edges of the black matrix 68, 82, 102, 132 to be included in the opposed board are set in consideration of the alignment margin between the opposed board and the active matrix board. Accordingly, even though there is a displacement between these boards, the gap between the adjacent pixel electrodes is optically shielded and thus the occurrence of the "block separation" is well suppressed.

In the embodiments shown in FIGS. 4, 6, 8, and 10, the bent portion (which is a slant portion between two bents) of the source line 74 and that of the pixel electrodes 97, 111, 127 are formed in a longitudinally central position of the pixel electrodes 77, 97, 111, and 127, respectively. But, to suppress the occurrence of the shadowing phenomenon and the "block separation", the bent portion is not necessarily provided strictly in a central position of the pixel electrode. Accordingly, in the present invention, the position of the bent portion to be formed on the pixel electrode or the source line is not limited to the longitudinally central position of each pixel electrode.

Note that the source line (signal line) may have a portion not covered by the pixel electrode in the widthwise direction of the source line so long as the uncovered portion is narrow enough not to hinder the effects of the above embodiments from being achieved.

<Fifth Embodiment>

FIG. 12 is a plan view of an active matrix board 151 of an active matrix type liquid crystal display apparatus (hereinafter referred to as simply an LCD apparatus) according to a fifth embodiment of the present invention.

FIG. 13 is a sectional view taken along line XIII—XIII of FIG. 12, and FIG. 14 is a sectional view taken along line XIV—XIV of FIG. 12.

The active matrix board 151 has the following construction. As shown in FIGS. 12–14, a plurality (only two are shown) of gate lines (scanning lines) 152 made of metal such as Al, Ta are disposed parallel with one another on an insulation substrate 151a made of glass. The film thickness of the gate line 152 is in the range of 2000 Å–5000 Å. Above the gate lines 152 a plurality (only two are shown) of source lines (signal lines) 154, 154' made of metal such as Al, Ta are disposed perpendicular to the gate lines 152, with a gate insulation film 153 made of SiNx or the like disposed between the gate lines 152 and the source lines 154, 154'. The film thickness of the gate insulation film 153 is in the range of 2000 Å–4000 Å. The dielectric constant of the gate insulation film 153 is three to eight. The film thickness of the source lines 154, 154' is in the range of 1000 Å–5000 Å.

Amorphous silicon TFTs 155 (only one of which is shown) are disposed in the neighborhood of the intersections

of the gate lines **152** and the source lines **154**, **154'**. Each amorphous silicon TFT **155** is composed by a gate electrode **156**, the gate insulation film **153**, an amorphous semiconductor layer **157**, an impurity-added semiconductor layer **158**, a source electrode **159**, and a drain electrode **160**. The gate electrode **156** and the gate line **152** are made of the same material. The source electrode **159**, the drain electrode **160**, and the source line **154**, **154'** are made of the same material. The amorphous semiconductor layer **157** is made of amorphous silicon formed by CVD (chemical vapor deposition). The film thickness of the amorphous semiconductor layer **157** is in the range of 500 Å–2000 Å. The gate electrode **156** is connected to the gate line **152** adjacent thereto. The source electrode **159** is connected to the source line **154** adjacent thereto.

Auxiliary capacitor lines **163** (only one of which is shown) are formed in the same layer as the gate lines **152** (namely, on the insulation substrate **151a**). On the gate insulation film **153**, the drain electrode **160** extends to a position of the auxiliary capacitor line **163** to form an auxiliary capacitor electrode **164** at an end of the drain electrode **160**. An interlaminar insulation film **161** is made of an organic material or an inorganic material. The film thickness of the interlaminar insulation film **161** is 1 μm to 4 μm. The dielectric constant of the interlaminar insulation film **161** is about two to four. A contact hole **165** is formed through the interlaminar insulation film **161** at the position of the auxiliary capacitor electrode **164**. The drain electrode **160** is connected to the pixel electrode **162** through the contact hole **165** and the auxiliary capacitor electrode **164**.

In the fifth embodiment, the auxiliary capacitor line **163** is disposed at a position where the pixel electrode **162** is bisected relative to the longitudinal direction of the pixel electrode into a TFT-side part (which is a part nearer to the TFT **155**) and a counter-TFT-side part (which is a part farther from the TFT **155**). That is, the center line of the auxiliary capacitor line **163** is substantially coincident to a transverse center line of the pixel electrode **162**. Each pixel electrode is bent at the position of the auxiliary capacitor line **163**. More specifically, each one of the opposite longitudinal side edges of the pixel electrode is bent twice in the vicinity of the transverse center line of the pixel electrode. As a result, the pixel electrode diagonally forms overhanging parts on either side along about half the length of the pixel electrode. A slant portion defined between the bends (referred to as "bent portion" below) of either side edge of the pixel electrode is placed just above the auxiliary capacitor line **163**. The overhanging part in the TFT-side part of the pixel electrode **162** overhangs over the source line **154'** on one side of the pixel electrode, with the interlaminar insulation film **161** disposed therebetween. The counter-TFT-side part of the pixel electrode **162** overhangs over the source line **154** on the other side of the pixel electrode, also with the interlaminar insulation film **161** disposed therebetween.

The LCD apparatus has an opposed board **166** with the following construction. That is, as shown in FIGS. **13** and **14**, color filters **167** are formed on an insulation substrate **166a** in the order of colors of red, green, and blue at a position corresponding to each pixel electrode **162**, **162'**, **162''**. A black matrix **168** is formed between the color filters **167** and **167**. The black matrix **168** serves as a patterned light shield film for preventing leak of light from the gaps between the adjacent pixel electrodes **162** and **162'**, **162** and **162''**. An opposed electrode **169** made of a transparent conductive material is formed over the color filters **167** and the black matrix **168**.

The active matrix board **151** and the opposed board **166** are spaced at a predetermined interval, with the pixel elec-

trodes **162**, **162'**, **162''** and the opposed electrode **169** opposed to each other. Then, a liquid crystal layer **170** is sandwiched between the active matrix board **151** and the opposed board **166**. A sealer is applied to the resulting laminate to complete the LCD apparatus.

As clearly shown in FIG. **14**, in the fifth embodiment, the pixel electrode **162** disposed over the auxiliary capacitor line **163** descends along a surface defining the contact hole **165** to be electrically connected to the auxiliary capacitor electrode **164** (hence, to the drain electrode **160**). Paying attention to the source line **154** on the left side as viewed in FIG. **12**, this source line **154** is covered by the overhanging part of the TFT-side part of the pixel electrode **162''** on the left side of the source line **154** and by the overhanging part of the counter-TFT-side part of the pixel electrode **162** on the right side of the source line **154**. This is also true of the source line **154'** on the right side of FIG. **12**.

If the auxiliary capacitor line **163** was not located in coincidence with the bent portions of the pixel electrodes **162**, **162'**, **162''**, a misalignment between layers would cause great variations in the coupling capacitance C_{sd} at the bent portions where the source lines **154**, **154'** are not covered with the adjacent pixel electrodes.

In contrast to this, in the fifth embodiment, the auxiliary capacitor line **163** is so disposed as if it bisects the pixel electrode **162** into the TFT **155**-side part and the counter-TFT **155**-side part. Accordingly, the bent portions of the side edges of the pixel electrode **162** located at the longitudinally central position of the pixel electrode are present directly above the auxiliary capacitor line **163**. Because the source lines (signal lines) **154**, **154'** and the auxiliary capacitor line **163** form the coupling capacitances, a part of an electric line of force emitted from the source lines **154**, **154'** terminates at, the auxiliary capacitor line **163**. Consequently, the coupling capacitance C_{sd} between the pixel electrode **162** at the bent portion and the source line **154**, **154'** becomes small.

Accordingly, even though there is a misalignment between layers, there is little variation in the coupling capacitance C_{sd} between the pixel electrode **162** and the source line **154** at the bent portion where the source line **154** is not covered with the adjacent pixel electrodes **162''** and **162**. Consequently, there is a great reduction of the variation amount in the coupling capacitance C_{sd1} between the source line **154** and the pixel electrode **162** and in the coupling capacitance C_{sd2} between the source line **154'** and the pixel electrode **162**. Thus, it is possible to suppress the occurrence of the "block separation".

That is, in the fifth embodiment, it is possible to suppress the occurrence of the "block separation" due to variations in the coupling capacitance C_{sd} between the pixel electrode **162** and the source lines **154**, **154'**.

<Sixth Embodiment>

In the fifth embodiment, the auxiliary capacitor line **163** is located at the position where the pixel electrode **162** is bisected into the TFT **155** side part and the part opposite from the TFT **155**. That is, the auxiliary capacitor line **163** is disposed along a transverse center line of the pixel electrode **162**. But, there are cases where the auxiliary capacitor line cannot be disposed such a position to improve the aperture ratio and the yield. The sixth embodiment is intended to cope with such a case.

FIG. **15** is a plan view of an active matrix board **171** of an active matrix type liquid crystal display apparatus (hereinafter referred to as simply an LCD apparatus) according to a sixth embodiment of the present invention. FIG. **16** is a sectional view taken along line XVI—XVI of FIG. **15**, and FIG. **17** is a sectional view taken along line XVII—XVII of FIG. **15**.

Referring to FIGS. 15 to 17, the active matrix board 171 has an insulation substrate 171a, gate lines 172, a gate insulation film 173, source lines 174, TFTs 175, an interlaminar insulation film 181, and pixel electrodes 182 which have the same constructions and functions as the insulation substrate 151a, the gate lines 152, the gate insulation film 153, source lines 154, 154', the TFTs 155, the interlaminar insulation film 161, and the pixel electrodes 162 of the active matrix board 151 in the fifth embodiment shown in FIGS. 12 to 14. Also, an opposed board 186 of the LCD apparatus of the sixth embodiment has an insulation substrate 186a, color filters 187, a patterned black matrix 188, and an opposed electrode 189 which are the same constructions and functions as the insulation substrate 166a, the color filters 167, the black matrix 168, and the opposed electrode 169 of the opposed board 166 of the fifth embodiment. Also, a liquid crystal layer 190 in the sixth embodiment has the same construction and function as the liquid crystal layer 170 in the fifth embodiment.

In the sixth embodiment, an auxiliary capacitor line 183 is disposed not along a transverse center line of the pixel electrode 182 but along a transverse line displaced toward the TFT 175 side with respect to the center line such that the auxiliary capacitor line 183 is parallel with the gate lines 172. A drain electrode 180 of the TFT 175 is extended to the auxiliary capacitor line 183 to form an auxiliary capacitor electrode 184 at an end of the drain electrode 180. The auxiliary capacitor electrode 184 is connected to the pixel electrode 182 at the position of the contact hole 185.

The auxiliary capacitor line 183 is provided with electrode portions 191 that extend along the underside of each source line 174 to a central portion of the pixel electrode 182. In this manner, as shown in FIG. 15, the bent portions of the side edges of the pixel electrode 182, which are formed at the position where the side edges are bisected, are positioned above the electrode portions 191 whose electric potentials are equal to the electric potential of the auxiliary capacitor line 183.

Therefore, though the auxiliary capacitor line 183 is not disposed in the middle of the pixel electrode 182, the LCD apparatus of the sixth embodiment is able to function similarly to the LCD apparatus in which the bent portions of the pixel electrode 182 are present directly above the auxiliary capacitor line 183. That is, the source line 174 at the bent portion and the electrode portion 191 form the coupling capacitance. Consequently, the coupling capacitance Csd between the pixel electrode 182 at the bent portion and the source line 174 is reduced.

If the pixel electrode 182 is bent over the auxiliary capacitor line 183, it follows that the bent portion will not be located in the middle of the pixel electrode 182. The result is that $Csd1 \neq Csd2$ and that the value of $(Csd1 - Csd2)$ in the equation (5) above becomes large. Thus, even if the dot inversion driving method is adopted, the shadowing phenomenon is likely to occur due to the coupling capacitance Csd between the pixel electrode 182 and the source line 174. <Seventh Embodiment>

FIG. 18 is a plan view of an active matrix board 201 of an active matrix type liquid crystal display apparatus (hereinafter referred to as simply an LCD apparatus) according to a seventh embodiment of the present invention. FIG. 19 is a sectional view taken along line XIX—XIX of FIG. 18, and FIG. 20 is a sectional view taken along line XX—XX of FIG. 18.

Referring to FIGS. 18 to 20, the active matrix board 201 has an insulation substrate 201a, gate lines 202, a gate insulation film 203, TFTs 205, an interlaminar insulation

film 206, auxiliary capacitor lines 208, auxiliary capacitor electrodes 209, and contact holes 210 which have the same constructions and functions as the insulation substrate 151a, the gate lines 152, the gate insulation film 153, the TFTs 155, the interlaminar insulation film 161, the auxiliary capacitor lines 163, the auxiliary capacitor electrodes 164, and the contact holes 165 of the active matrix board 151 in the fifth embodiment shown in FIGS. 12 to 14. Also, an opposed board 211 of the LCD apparatus of the seventh embodiment has an insulation substrate 211a, color filters 212, a patterned black matrix 213, and an opposed electrode 214 which are the same constructions and functions as the insulation substrate 166a, the color filters 167, the black matrix 168, and the opposed electrode 169 of the opposed board 166 of the fifth embodiment. Also, a liquid crystal layer 215 in the seventh embodiment has the same construction and function as the liquid crystal layer 170 in the fifth embodiment.

Unlike the fifth embodiment, both side edges of each pixel electrode 207 in the seventh embodiment are not bent but straight. Thus, the pixel electrode 207 is rectangular in shape. Instead, each source line 204 is bent at the position of the auxiliary capacitor line 208 that is located at a position where the pixel electrode 207 is bisected into a TFT 205-side part and a counter-TFT 205-side part which is a part opposite from the TFT 205. The TFT-side part of each pixel electrode 207 is laid over the corresponding part of the source line 204 positioned on one side (e.g., the right-hand side) of the pixel electrode 207, while the counter-TFT-side part of the pixel electrode 207 is laid over the corresponding part of the source line 204 positioned on the other side (e.g., the left-hand side) of the pixel electrode 207, with the interlaminar insulation film 206 interposed between the source lines and the pixel electrodes.

That is, in the seventh embodiment, unlike the fifth embodiment in which both side edges of the pixel electrode are bent, the source line 204 is bent. By thus doing, it is possible to reduce the coupling capacitance Csd between the pixel electrode 207 and the source line 204 at the bent portion, similarly to the fifth embodiment. Accordingly, it is possible to suppress the occurrence of the "block separation" due to a misalignment between layers.

Further, in the seventh embodiment, the pixel electrode 207 is formed rectangularly, similarly to the conventional active matrix type LCD apparatus shown in FIG. 28. Therefore, the color filter 212 and the black matrix 213 can be easily formed.

In the seventh embodiment, the auxiliary capacitor line 208 is located at the position where the pixel electrode 207 is bisected into the TFT 205-side part and the counter-TFT 205-side part. But, if the auxiliary capacitor line 208 cannot be disposed along the transverse center line of the pixel electrode 207, the auxiliary capacitor line 208 may be provided with electrode portions extending along the underside of each source line 204 to the bent portions thereof, as in the case of the sixth embodiment, so that the bent portions of the source lines 204 are placed above the electrode portions, which have an electric potential equal to that of the auxiliary capacitor line 208. <Eighth Embodiment>

FIG. 21 is a plan view of an active matrix board 221 of an active matrix type liquid crystal display apparatus (hereinafter referred to as simply an LCD apparatus) according to an eighth embodiment of the present invention. FIG. 22 is a sectional view taken along line XXII—XXII of FIG. 21, and FIG. 23 is a sectional view taken along line XXIII—XXIII of FIG. 21.

Referring to FIGS. 21 to 23, the active matrix board 221 in the eighth embodiment has an insulation substrate 221a, gate lines 222, a gate insulation film 223, source lines 224, TFTs 225, an interlaminar insulation film 226, pixel electrodes 227, auxiliary capacitor electrodes 229, and contact holes 230 which have the same constructions and functions as the insulation substrate 151a, the gate lines 15, the gate insulation film 153, the source lines 154, 154', the TFTs 155, the interlaminar insulation film 161, the pixel electrodes 162, the auxiliary capacitor electrodes 164, and the contact holes 165 of the active matrix board in the fifth embodiment shown in FIGS. 12 to 14. Also, an opposed board 231 in the eighth embodiment has an insulation substrate 231a and an opposed electrode 234 which are the same constructions and functions as the insulation substrate 166a and the opposed electrode 169 of the opposed board 166 of the fifth embodiment. Also, a liquid crystal layer 235 in the eighth embodiment has the same construction and function as the liquid crystal layer 170 in the fifth embodiment.

In the eighth embodiment, a light shield film 236 made of the same material as that of the gate lines 222 is disposed in the same layer as the gate lines 222 to optically shield the gap between adjacent pixel electrodes 227 and 227. Thus, it is unnecessary to form the black matrix 233 on the opposed board 231 in a location corresponding to the gap between the adjacent pixel electrodes 227 and 227. Thus it is enough to form the black matrix 233 only in positions in which it confronts the TFTs 225.

The accuracy of the alignment between the active matrix board 221 and the opposed board 231 is generally about ± 5 μm , whereas the accuracy of the alignment between the layers of the active matrix board 221 is less than ± 1 μm . Thus, the light shield film 236 of the active matrix board 221 is allowed to be made smaller in width than the black matrix 233 that would be used without the light shield film 236. Also, because provision of the light shield film 236 eliminates the black matrix 233 in the corresponding locations in the opposed board, the area of the color filters 232 is increased, resulting in the improved aperture ratio.

Furthermore, because the area of the black matrix 233 disposed on the opposed board 231 is reduced, it is possible to widen the bonding margin between the active matrix board 221 and the opposed board 231.

The light shield film 236 is connected to the auxiliary capacitor line 228. Thus, owing to the field shield effect of the light shield film 236, it is possible to reduce the coupling capacitance Csd between the source line 224 and the pixel electrode 227 to thereby suppress the occurrence of the shadowing phenomenon due to the coupling capacitance Csd. Further, because the absolute amount of the coupling capacitance Csd decreases, there is also a reduction in the amount of change of the coupling capacitance Csd due to a misalignment between layers. Thus, it is possible to further suppress the occurrence of the "block separation". The light shield film 236 may be connected to the gate line 222. Also, the light shield film 236 does not have to be connected to the auxiliary capacitor line 228 or the gate line 222.

In the eighth embodiment, the construction in which the light shield film 236 is provided and the formation of the black matrix 233 is omitted owing to the provision of the light shield film 236 has been applied to the fifth embodiment. This construction may be applied to the sixth and seventh embodiments.

In the fifth to eighth embodiments, the bent portions (which are slant portions between the bents) of the pixel electrodes 162, 182, 227 and that of the source line 204 are formed in a longitudinally central position of the pixel

electrodes 162, 182, 227, and 207, respectively. But, to suppress the occurrence of the shadowing phenomenon, the bent portion is not necessarily provided strictly in a central position of the pixel electrode. Accordingly, in the present invention, the position of the bent portion to be formed on the pixel electrode or the source line is not limited to the longitudinally central position of each pixel electrode.

Note that the source line (signal line) may have a portion not covered by the pixel electrode in the widthwise direction of the source line so long as the uncovered portion is narrow enough not to hinder the effects of the above embodiments from being achieved.

The invention being thus described, it will be obvious that the same may be varied in many ways. Such variations are not to be regarded as a departure from the spirit and scope of the invention, and all such modifications as would be obvious to one skilled in the art are intended to be included within the scope of the following claims.

What is claimed is:

1. An active matrix type liquid crystal display apparatus comprising:

- an insulation substrate;
- scanning lines formed on the insulation substrate;
- signal lines extending in a direction intersecting a direction in which the scanning lines extend;
- switching devices provided in the vicinity of each intersection of the scanning and signal lines such that the switching devices are arrayed in a matrix form;
- an interlaminar insulation film disposed on or above the scanning lines, the signal lines, and the switching devices;
- pixel electrodes formed on the interlaminar insulation film and arranged in a matrix form, each electrode being connected to an output terminal of an associated switching device,

wherein only a part of each of opposite side portions of one pixel electrode widthwise covers two signal lines extending adjacent to the pixel electrode; and

wherein each signal line is bent twice between two adjacent scanning lines such that two generally parallel but longitudinally displaced parts are formed, and these two parts are covered by opposed side portions of two adjacent pixel electrodes, respectively.

2. The active matrix type liquid crystal display apparatus according to claim 1, wherein each pixel electrode covers the associated switching device.

3. The active matrix type liquid crystal display apparatus according to claim 1, wherein each switching device is disposed in the vicinity of a gap between two adjacent pixel electrodes.

4. The active matrix type liquid crystal display apparatus according to claim 1, further comprising an opposed board having a black matrix, and wherein the black matrix is located between two adjacent pixel electrodes in such a manner that the black matrix overlaps each one of these pixel electrodes by at least an amount corresponding to an alignment margin of the opposed board relative to the insulation board.

5. The active matrix type liquid crystal display apparatus according to claim 4, wherein in a location where the signal line is covered by the pixel electrode, an edge of the black matrix is disposed along a center line of the pixel electrode or on an inner side of the pixel electrode than the center line.

6. The active matrix type liquid crystal display apparatus according to claim 1, further comprising a light shield film provided on the insulation substrate in such a manner that the light shield film spans a gap between the adjacent pixel electrodes.

7. The active matrix type liquid crystal display apparatus according to claim 5, further comprising a light shield film provided on the insulation substrate in such a manner that the light shield film spans a gap between the adjacent pixel electrodes.

8. An active matrix type liquid crystal display apparatus comprising:

- an insulation substrate;
- scanning lines formed on the insulation substrate;
- signal lines extending in a direction intersecting direction in which the scanning lines extend;
- switching devices provided in the vicinity of each intersection of the scanning and signal lines such that the switching devices are arrayed in a matrix form;
- an interlaminar insulation film disposed on or above the scanning lines, the signal lines, and the switching devices;
- pixel electrodes formed on the interlaminar insulation film and arranged in a matrix form, each electrode being connected to an output terminal of an associated switching device,

wherein only a part of each of opposite side portions of one pixel electrode widthwise covers two signal lines extending adjacent to the pixel electrode;

wherein said parts of the pixel electrode covering the two signal lines adjacent to the pixel electrode are parts that overhang from side edges of the pixel electrode; and

wherein both side edges of each pixel electrode are bent twice such that the overhanging parts are diagonally formed on the respective sides of the pixel electrode and these overhanging parts cover the two signal lines adjacent to the pixel electrode.

9. The active matrix type liquid crystal display apparatus according to claim 8, wherein a portion between the two bents of each side edge of the pixel electrode forms a slant.

10. An active matrix type liquid crystal display apparatus comprising:

- an insulation substrate;
- scanning lines formed on the insulation substrate;
- auxiliary capacitor lines arranged parallel to the scanning lines;
- signal lines extending in a direction intersecting a direction in which the scanning lines extend;
- switching devices provided in the vicinity of each intersection of the scanning and signal lines such that the switching devices are arrayed in a matrix form;
- an interlaminar insulation film disposed on or above the scanning lines, auxiliary capacitor lines, the signal lines, and the switching devices; and
- pixel electrodes formed on the interlaminar insulation film and arranged in a matrix form, each electrode being connected to an output terminal of the associated switching device,

wherein both side edges of each pixel electrode are bent twice such that the overhanging parts are formed on the respective sides of the pixel electrode and these overhanging parts cover two signal lines adjacent to the pixel electrode, and

wherein the auxiliary capacitor line underlies a portion between the two bents of each side edge of the pixel electrode.

11. The active matrix type liquid crystal display apparatus according to claim 10, further comprising a light shield film provided on the insulation substrate in such a manner that the light shield film spans a gap between the adjacent pixel electrodes.

12. The active matrix type liquid crystal display apparatus according to claim 11, wherein said light shield film is electrically connected to either the auxiliary capacitor line or the scanning line.

13. The active matrix type liquid crystal display apparatus according to claim 10, wherein the portion between the two bents of each side edge of the pixel electrode forms a slant.

14. The active matrix type liquid crystal display apparatus according to claim 10,

wherein the auxiliary capacitor line includes electrode portions that extend toward a portion between the two bents of each side edge of the pixel electrode such that the electrode portions underlie the portions between the two bents of each side edge of the pixel electrode.

15. The active matrix type liquid crystal display apparatus according to claim 10, wherein the overhanging parts on both sides of the pixel electrodes have approximately same dimensions.

16. An active matrix type liquid crystal display apparatus comprising:

- an insulation substrate;
- scanning lines formed on the insulation substrate;
- signal lines extending in a direction intersecting a direction in which the scanning lines extend;
- switching devices provided in the vicinity of each intersection of the scanning and signal lines such that the switching devices are arrayed in a matrix form;
- an interlaminar insulation film disposed on or above the scanning lines, auxiliary capacitor lines, the signal lines, and the switching devices;
- pixel electrodes formed on the interlaminar insulation film and arranged in a matrix form, each electrode being connected to an output terminal of the associated switching device;

wherein between two adjacent scanning lines, each signal line has a first and second generally parallel but longitudinally displaced straight portions and a transition portion connecting the first and second straight portions;

wherein each pixel electrode has a shape of a rectangle that has two side portions extending along the first and second straight portions of neighboring two signal lines; and

wherein one of the two sides of each pixel electrode covers the first portion of one of the two neighboring two signal lines, and the other side portion of the pixel electrode covers the second portion of the other of the two neighboring two signal lines.

专利名称(译)	有源矩阵型液晶显示装置		
公开(公告)号	US6956633	公开(公告)日	2005-10-18
申请号	US10/624935	申请日	2003-07-21
[标]申请(专利权)人(译)	冈田弘 BAN ATSUSHI		
申请(专利权)人(译)	冈田弘 BAN ATSUSHI		
当前申请(专利权)人(译)	夏普株式会社		
[标]发明人	OKADA YOSHIHIRO BAN ATSUSHI		
发明人	OKADA, YOSHIHIRO BAN, ATSUSHI		
IPC分类号	G02F1/13 G02F1/1362 G02F1/1343		
CPC分类号	G02F1/136227 G02F1/134309 G02F2001/13625		
优先权	2000094314 2000-03-30 JP 2000094330 2000-03-30 JP		
其他公开文献	US20040017521A1		
外部链接	Espacenet USPTO		

摘要(译)

在有源矩阵型液晶显示装置中，每个像素电极在其相对的侧边缘处具有悬垂部分。这些像素电极的悬垂部分分别覆盖位于像素电极相对侧的两条信号线。

