



US006617177B1

(12) **United States Patent**
Winer

(10) **Patent No.:** **US 6,617,177 B1**
(45) **Date of Patent:** **Sep. 9, 2003**

(54) **LIQUID CRYSTAL DISPLAY DEVICES HAVING FILL HOLES AND ELECTRICAL CONTACTS ON THE BACK SIDE OF THE DIE**

(75) **Inventor:** **Paul Winer, Santa Clara, CA (US)**
(73) **Assignee:** **Intel Corporation, Santa Clara, CA (US)**

(*) **Notice:** Subject to any disclaimer, the term of this patent is extended or adjusted under 35 U.S.C. 154(b) by 0 days.

(21) **Appl. No.:** **10/231,392**
(22) **Filed:** **Aug. 28, 2002**

Related U.S. Application Data

- (62) Division of application No. 10/128,602, filed on Apr. 22, 2002.
- (51) **Int. Cl.⁷** **H01L 21/66; H01L 21/44; H01L 21/00; H01L 21/301**
- (52) **U.S. Cl.** **438/14; 438/30; 438/108; 438/460; 438/462; 438/15; 438/16; 438/17; 438/18**
- (58) **Field of Search** **438/14, 30, 108, 438/460, 462, 15, 16, 17, 18**

(56) **References Cited**

U.S. PATENT DOCUMENTS

5,576,630 A * 11/1996 Fujita

- 5,614,839 A * 3/1997 Bosacchi
- 5,694,053 A * 12/1997 Smith
- 5,834,327 A * 11/1998 Yamazaki et al.
- 6,071,755 A * 6/2000 Baba et al.
- 6,111,424 A * 8/2000 Bosacchi
- 6,195,149 B1 * 2/2001 Kodera et al.
- 6,208,405 B1 * 3/2001 Sakong et al.
- 2002/0159020 A1 * 10/2002 Sojourner et al.

* cited by examiner

Primary Examiner—John F. Niebling

Assistant Examiner—Stanetta Isaac

(74) *Attorney, Agent, or Firm*—Blakely, Sokoloff, Taylor & Zafman LLP

(57) **ABSTRACT**

A method of fabricating LCOS devices and testing them at the wafer-scale to identify known-bad dice, to facilitate completing fabrication of only known-good dice. A wafer-scale transparent electrode glass is temporarily placed over the wafer, and liquid crystal material is injected into the LCOS device cavities through fill holes extending through the wafer. After removing the glass and separating the wafer into dice, only the good dice have their die-scale glass attached, liquid crystal material re-injected, solder bumps affixed, and substrate attached.

9 Claims, 4 Drawing Sheets

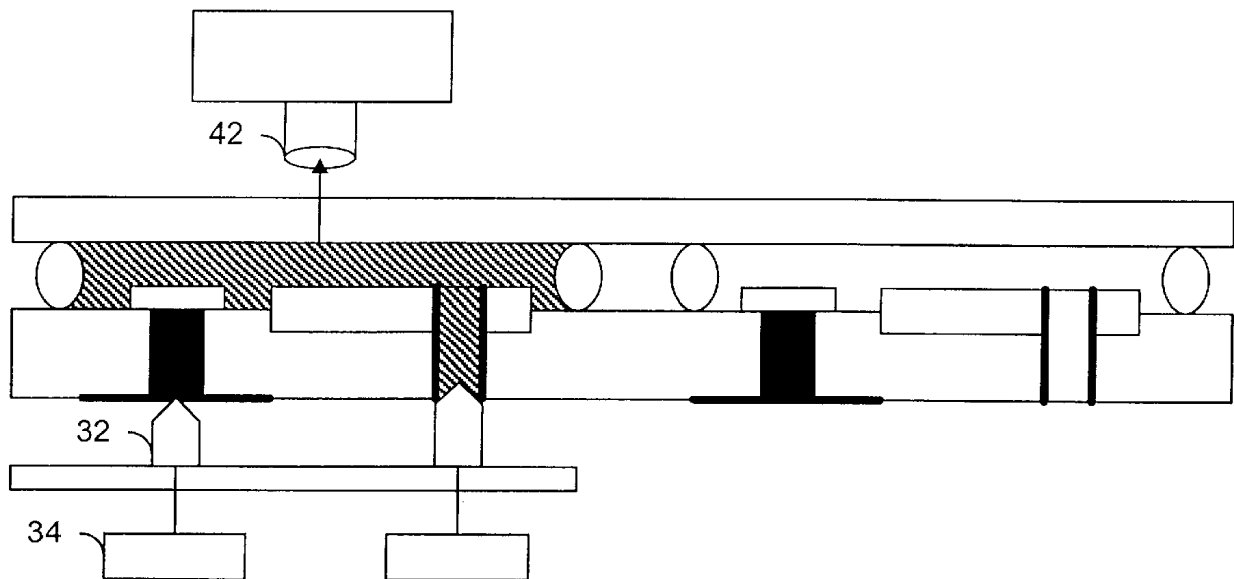

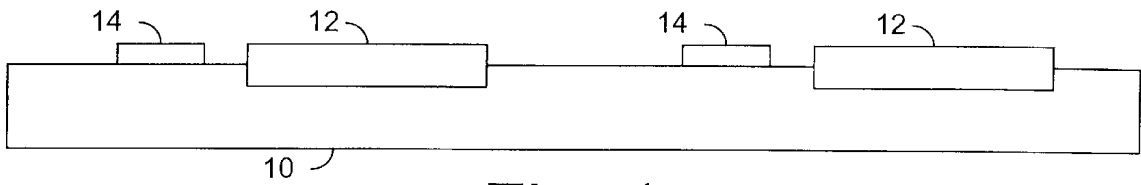

Fig. 1

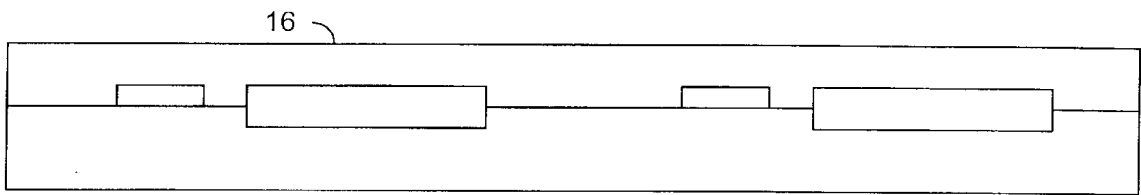

Fig. 2

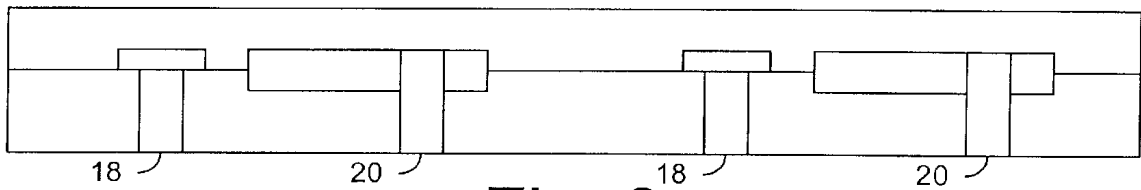

Fig. 3

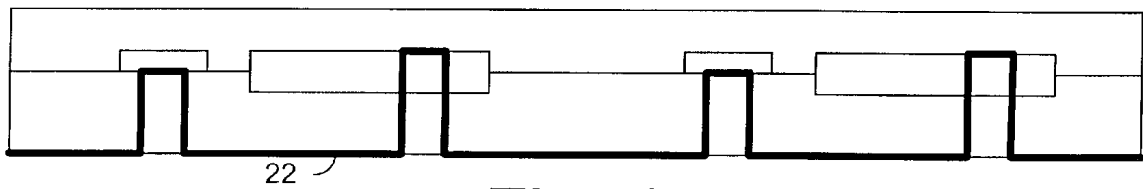

Fig. 4

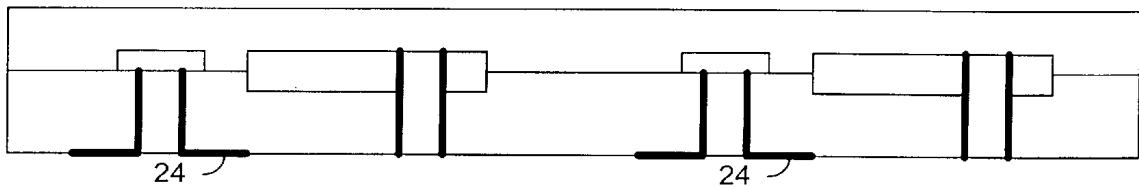

Fig. 5

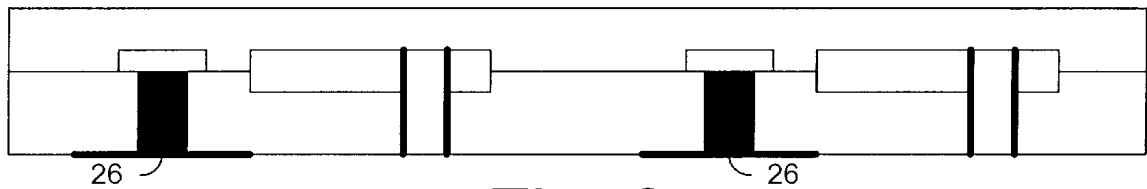

Fig. 6

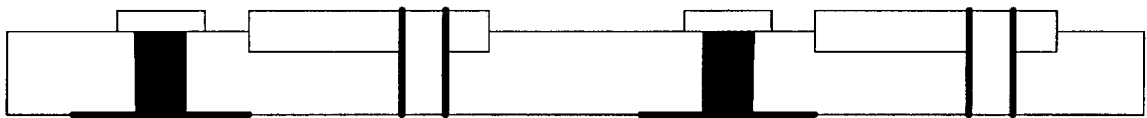

Fig. 7

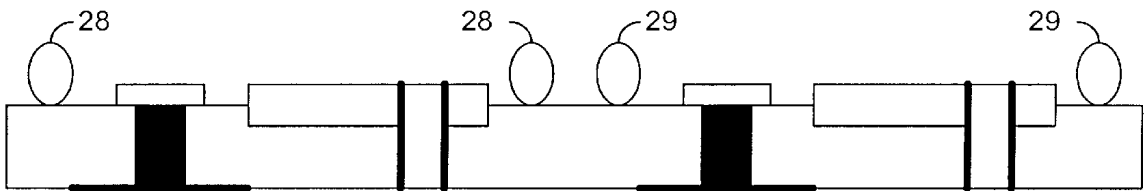

Fig. 8

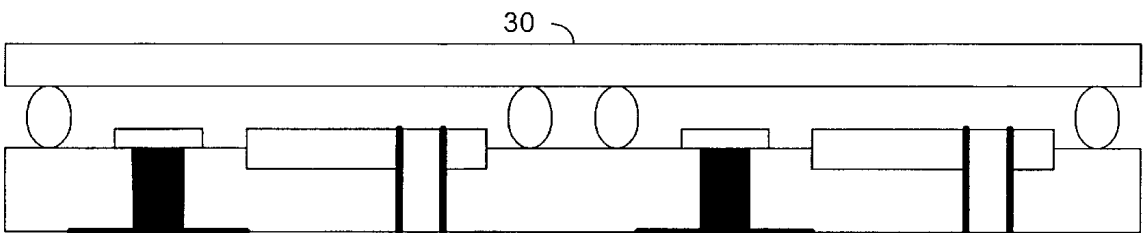

Fig. 9

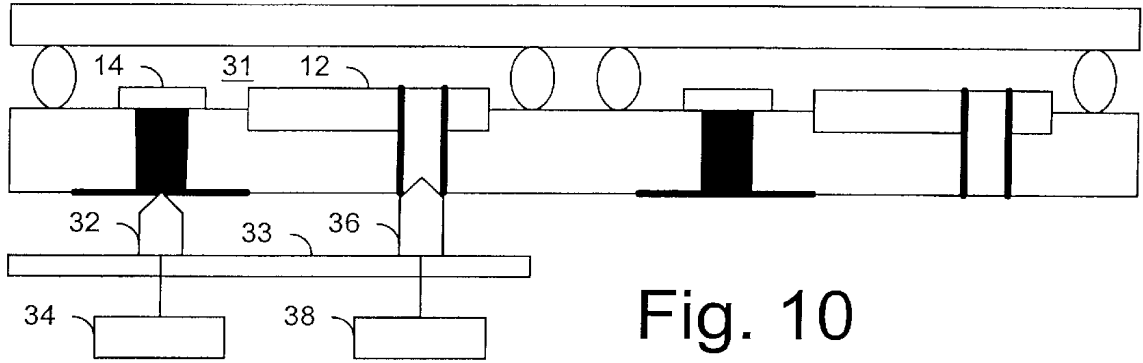

Fig. 10

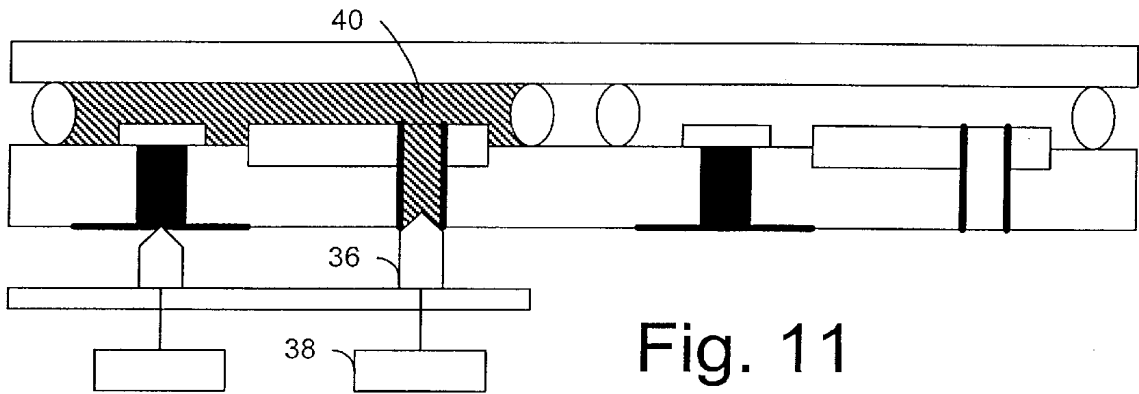

Fig. 11

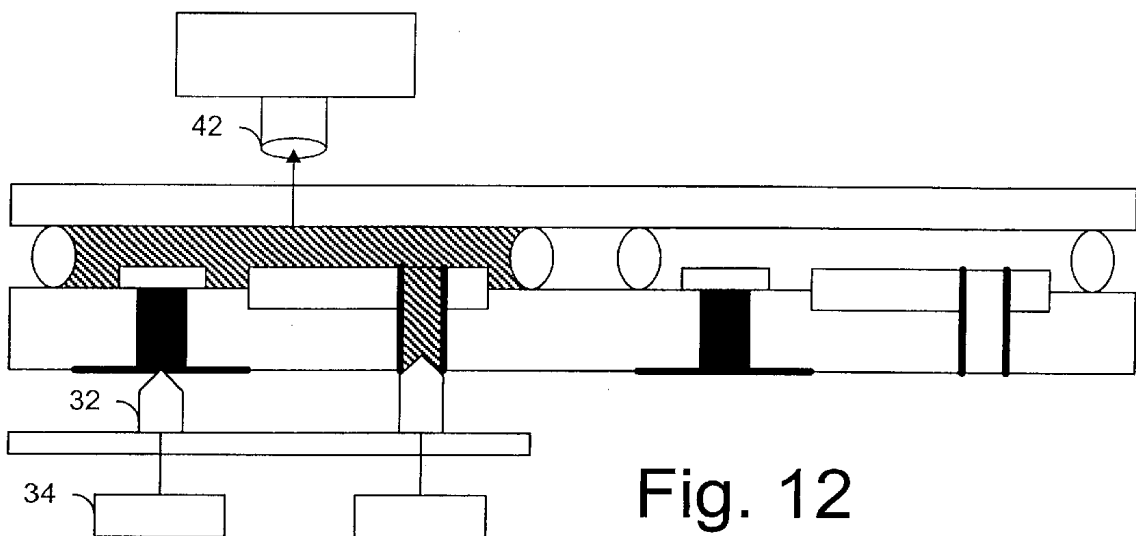

Fig. 12

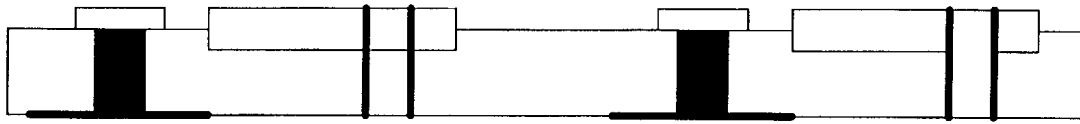

Fig. 13

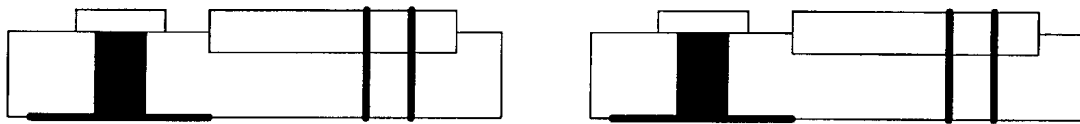

Fig. 14

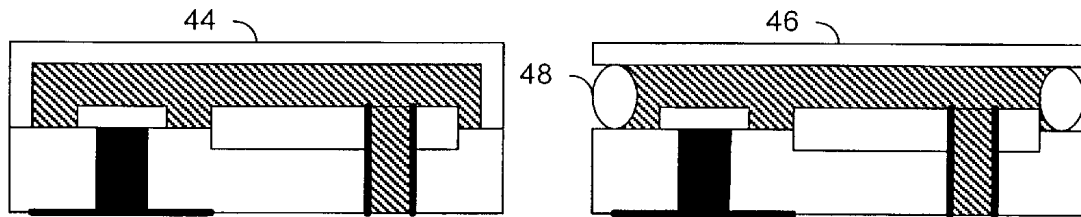

Fig. 15

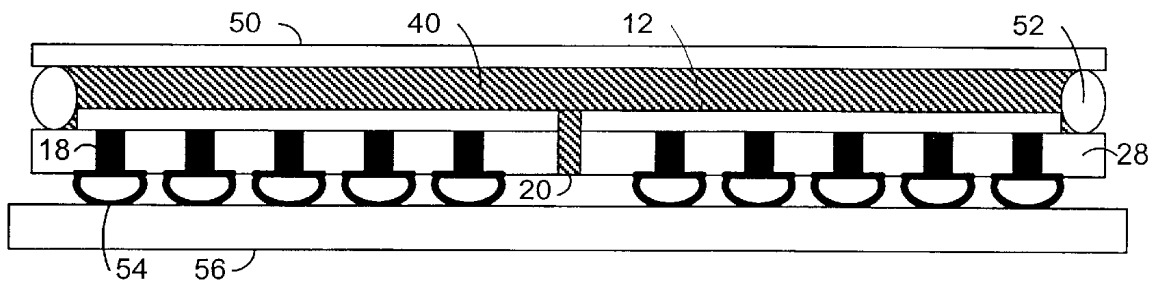

Fig. 16

LIQUID CRYSTAL DISPLAY DEVICES HAVING FILL HOLES AND ELECTRICAL CONTACTS ON THE BACK SIDE OF THE DIE

This Application is a divisional of Ser. No. 10/128,602
Apr. 22, 2002.

BACKGROUND OF THE INVENTION

1. Technical Field of the Invention

This invention relates generally to manufacturing and testing of liquid crystal on semiconductor display devices, and more specifically to wafer-level testing and device structures that support such.

2. Background Art

Liquid crystal on silicon (LCOS) display devices include an array of display pixels fabricated on a silicon or other semiconductor substrate with associated control circuitry, and a quantity of liquid crystal material encapsulated overlying the display pixel array. When appropriate electrical signals are applied to the various pixels, they alter the transparency or polarization or reflectivity of the liquid crystal material which overlies their respective areas.

Unfortunately, at present, the LCOS chips must be fully fabricated and assembled before they can be tested. Of any given semiconductor wafer, there will typically be a number—sometimes a large number—of semiconductor dice which are defective and must be rejected. Overall costs are increased, materials are wasted, and factory output is reduced, by the ultimately unnecessary completion and assembly of these defective devices.

Also, on present LCOS devices, the wire bond attach pads are located on the same side of the die as the liquid crystal display structures. This makes testing difficult, and makes test head devices complicated and difficult to make and use.

What is needed, then, is a way to perform wafer-level testing of LCOS devices before their final fabrication steps and their assembly.

BRIEF DESCRIPTION OF THE DRAWINGS

The invention will be understood more fully from the detailed description given below and from the accompanying drawings of embodiments of the invention which, however, should not be taken to limit the invention to the specific embodiments described, but are for explanation and understanding only.

FIGS. 1–9 show various incremental stages of completion of a wafer of LCOS devices, according to one embodiment of the invention.

FIGS. 10–12 show various incremental stages of wafer-level testing of the wafer of LCOS devices, according to one embodiment of the invention.

FIGS. 13–16 show various incremental stages of post-test completion and assembly of known-good LCOS dice, according to one embodiment of the invention.

DETAILED DESCRIPTION

FIG. 1 illustrates a semiconductor wafer **10** that has a first side and a second side. A number of display pixel arrays **12** are fabricated on the first side of the wafer. For simplicity of illustration, only two display pixel arrays are shown. After manufacturing is complete, each display pixel array will typically occupy its own chip cut from the wafer. Each chip will have a plurality of external connections or external

electrodes **14** such as bond pads for routing power, ground, and signals to the chip. For ease of illustration, only one external connection is shown for each of the display pixel arrays, but each display pixel array will typically have a large number of such external connections. The term “external electrode” is intended to signify an electrode which will carry a signal off-chip, not necessarily an electrode which is itself external to the chip or on the exterior surface of the chip.

FIG. 2 shows a protective layer **16** which can optionally be formed overlying the display pixel arrays.

FIG. 3 shows an electrical via **18** formed through the semiconductor wafer from the second side to the first side and into contact with the external connector, and at least one liquid crystal fill via **20** formed through the semiconductor wafer. In various embodiments, any number of electrical vias and any number of liquid crystal fill vias can be formed. The vias can also be termed holes, and need not necessarily be formed in any particular manner, although one suitable method is by laser drilling. In some embodiments, the liquid crystal fill via(s) can be located so as to extend through the display pixel array, as shown, while in other embodiments, they can be located to the side of the display pixel array, while in still other embodiments, both locations can be used. Further discussion will omit repetitively pointing out that the various structures are formed for each display pixel array, in the interest of readability.

FIG. 4 shows a metal or other suitably conductive layer **22** formed so as to provide electrical contact with the external connectors. In one embodiment, the conductive layer is formed by depositing metal on the surface of the semiconductor substrate and the walls of the electrical via. In some embodiments, it may be acceptable to allow the metal to also line the liquid crystal fill via, while in other embodiments the liquid crystal fill via may be plugged prior to the metal deposition.

FIG. 5 shows patterning of the metal layer to form pads **24** or other suitable structures on the second side of the wafer and in contact with the electrical vias and appropriately not in contact with other structures, including each other.

FIG. 6 shows a conductive plug **26** or conductor formed in the electrical via, to improve conductivity of the path to the external connector. The liquid crystal fill via is not plugged or, if it is plugged, the plug is subsequently removed.

FIG. 7 shows the removal of the protective layer which had been overlying the display pixel array.

FIG. 8 shows the formation of seals **28**, **29** surrounding respective display pixel arrays. The reader will appreciate that the seals are shown in cross-section, and that this is why there appear to be two seals for each. In some embodiments, a single seal may be used, surrounding the entire wafer; in such embodiments, individual seals will later be formed for individual display pixel arrays.

In the prior art, a seal was formed around a display pixel array, with a small gap somewhere in the perimeter of the seal, to facilitate injection of the liquid crystal material. In some embodiments of this invention, the seal can advantageously be monolithic or continuous without any such gap.

FIG. 9 shows a transparent electrode **30** placed to overlie the display pixel array and be in contact with the seal, encapsulating a cavity **31** between the transparent electrode and the wafer, with the seals defining a perimeter of the cavity for each LCOS device. In one embodiment, the transparent electrode is a layer of coated or impregnated

glass. In one embodiment, the glass may be substantially the size of the wafer, so as to overlie all of the LCOS devices, while in other embodiments it may be smaller, in some cases as small as one separate glass for each LCOS device. The reader will appreciate that various details of the LCOS device have been omitted, such as the formation of logic circuitry and the like, and that these can of course be formed within the scope of this invention.

Furthermore, while the external contact **14** has been shown as being in the cavity, it could be located outside the cavity, beyond the perimeter of the seal. Also, while it has been shown as being in a top metal layer, it could be in a buried layer; with the electrical via extending to the surface of the back side of the wafer, there is no longer any need for the external contact to be on the top or otherwise externally accessible layer on the front side of the wafer.

FIG. **10** shows a testing probe card **33** which has an electrical probe **32** connected to electrical test logic **34** and a liquid crystal injection needle **36** connected to a reservoir **38** of liquid crystal material. In some embodiments, the electrical probe and the fill needle can advantageously be spaced such that the electrical probe contacts the electrical via or plug or associated pad, at the same time that the liquid crystal injection needle is in a suitable proximity to the liquid crystal fill via. In other embodiments, the electrical probe and the fill needle can be on separate probe cards and their operations performed at different times. In some embodiments, the probe card may contain multiple electrical probes for contacting all of the LCOS device's electrical vias at the same time. In some embodiments, the probe card may contain multiple fill needles, to utilize all of the LCOS device's fill vias. In some embodiments, the probe card can include electrical probes and fill needles for testing more than one LCOS device at a time. In one embodiment, the probe card contains an entire wafer's worth of electrical probes and fill needles.

It is significant to note that the probe card operates on the back side of the wafer, or the side opposite the liquid crystal structures. This can, in some embodiments, enable simplified construction or usage of the probe card. It can also, in some embodiments, enable the die size to be reduced to a size such that the front side of the chip does not have enough surface area external to the liquid crystal seal perimeter for placement of the requisite number of external contacts. In the extreme case, the chip can be reduced to the size of the seal perimeter.

FIG. **11** shows the injection of the liquid crystal material **40** through the fill via. In some embodiments, the liquid crystal material can be withdrawn from the LCOS device and returned to the reservoir for reuse, such as if the LCOS device is defective. In other embodiments, it can simply be left in place from this stage of manufacturing onward.

FIG. **12** shows the electrical and optical testing of the LCOS device. The test logic **34** drives the external contact with the electrical probe **32**, and a visual inspection system such as a camera **42** or a human checks to see that the correct pattern, color, brightness, etc. are displayed in the liquid crystal material. In some embodiments, the test logic also checks the operation of other circuitry (not shown) on or associated with the LCOS device. Some of the external contacts may be used for outbound signals sent from the chip to the test device.

FIG. **13** shows the optional removal of the liquid crystal material and the wafer-size glass, after testing is complete. In some other embodiments, the wafer-size glass is simply sectioned along with the wafer, and is left in place on the finished dice.

FIG. **14** shows the wafer having been sectioned into multiple dice, some of which are known-good and some of which are known-bad, in embodiments of the manufacturing methodology in which testing is done prior to wafer sectioning. The reader should note that the back side fill and test structures can be used after wafer sectioning, in addition to, or in lieu of, wafer-scale fill and testing.

FIG. **15** shows, on the right side, a known-good die being completed by the addition of a seal **48** and a die-scale glass electrode **46**. In some embodiments, the original seal may be retained. In some such embodiments, the wafer-scale glass is sectioned along with the wafer, and the glass electrode **46** is simply the piece of the original glass that was over this LCOS device. In some embodiments, the original liquid crystal material was never withdrawn; in others, liquid crystal material is again injected into the LCOS device. In some embodiments, one or more of the fill vias can be used to remove air while the liquid crystal material is injected through others, to avoid bubbles and obtain a complete fill. At some suitable stage, the fill vias are plugged or otherwise prevented from leaking.

FIG. **15** shows, on the left side, a known-good die being completed in a different manner, without the use of a seal. A monolithic glass structure **44** is formed or placed over the LCOS device in a self-sealing manner, such as by being deposited directly on the die or by being glued to the die.

FIG. **16** shows the completion and assembly of a single LCOS device, which is not drawn to the same scale as the other FIGS. (The absolute or relative scale of the various FIGS. is not intended to have any particular significance, nor any effect upon the claims; the fact that FIG. **16** is drawn differently than e.g. FIG. **15** is merely pointed out so that the reader does not attempt to somehow vertically rationalize FIGS. **16** and **15**.) The individual die **28** includes many electrical vias **18**, and at least one fill via **20** through which the liquid crystal material **40** has been injected. The seal **52** (which can either be an originally placed seal **18** or a newly placed seal) supports the glass electrode **50** (again, either the original or a newly placed piece) and prevents the liquid crystal material from leaking. In some embodiments, solder bumps **54** are formed in contact with respective ones of the pads that provide connection to the typically smaller electrical vias. A substrate **56** is placed in contact with the solder bumps, and the solder bumps are flowed or melted to provide good connection between the LCOS device's via pads and corresponding pads (not shown) on the substrate. The substrate may contain other devices (not shown), such as passive components, semiconductor chips, and the like.

The reader will appreciate that the invention has been explained with reference to one simplistic exemplary embodiment, and that the invention is not limited to the specific details given above.

Reference in the specification to "an embodiment," "one embodiment," "some embodiments," or "other embodiments" means that a particular feature, structure, or characteristic described in connection with the embodiments is included in at least some embodiments, but not necessarily all embodiments, of the invention. The various appearances "an embodiment," "one embodiment," or "some embodiments" are not necessarily all referring to the same embodiments.

If the specification states a component, feature, structure, or characteristic "may," "might," or "could" be included, that particular component, feature, structure, or characteristic is not required to be included. If the specification or claim refers to "a" or "an" element, that does not mean there is

5

only one of the element. If the specification or claims refer to “an additional” element, that does not preclude there being more than one of the additional element.

Those skilled in the art having the benefit of this disclosure will appreciate that many other variations from the foregoing description and drawings may be made within the scope of the present invention. Indeed, the invention is not limited to the details described above. Rather, it is the following claims including any amendments thereto that define the scope of the invention.

What is claimed is:

1. A method of manufacturing a plurality of LCOS devices from one semiconductor wafer, the method comprising:

fabricating a plurality of display pixel elements on a first side of the semiconductor wafer;

fabricating at least one external electrode on each of the display pixel elements;

forming a plurality of first holes through the semiconductor wafer and into contact with respective ones of the at least one external electrode;

forming a plurality of second holes through the semiconductor wafer; and

fabricating a plurality of electrical conductors each disposed in a respective one of the at least one first holes and in electrical contact with the respective external electrode.

2. The method of claim **1** further comprising:

placing a transparent electrode overlying the first side of the semiconductor wafer and enclosing each of a plurality of the display pixel elements and at least one of the second holes in a respective cavity; and

filling at least one of the cavities with liquid crystal material by injecting the liquid crystal material through the at least one of the second holes.

3. The method of claim **2** further comprising:

applying electricity to the enclosed display pixel elements; and

determining whether the liquid crystal material in each of the respective cavities is activated by the electricity, to detect defective LCOS devices and good LCOS devices.

6

4. The method of claim **3** further comprising:

separating the wafer into separate dice;

completing manufacturing of the dice containing good LCOS devices; and

not completing manufacturing of the dice containing defective LCOS devices.

5. The method of claim **4** wherein completing manufacturing of the good LCOS devices comprises, for each respective die containing a good LCOS device:

placing a die-scale transparent electrode on the die to define a cavity; and

filling the cavity with liquid crystal material by injecting the liquid crystal material through at least one of the second holes through the die.

6. The method of claim **5** wherein completing manufacturing of the good LCOS devices further comprises, for each respective die containing a good LCOS device:

attaching solder bumps to the electrical conductors of the die; and

attaching a substrate to the solder bumps.

7. A method of testing a wafer including LCOS devices, the method comprising:

placing a transparent electrode overlying a plurality of the LCOS devices to define over each a cavity encompassing a pixel element;

injecting liquid crystal material into the cavities through respective holes which extend through the wafer, wherein the injecting and electrically activating are performed with a probe card which includes an electrical contact and a liquid crystal injection needle; and electrically activating the pixel elements in the cavities.

8. The method of claim **7** wherein the electrical contact and the liquid crystal injection needle are spaced on the probe card to match a spacing of a corresponding electrical conductor and hole of the wafer.

9. The method of claim **1** wherein all external electrical contacts are formed on a second side of the semiconductor wafer.

* * * * *

专利名称(译)	液晶显示装置在模具的背面具有填充孔和电触点		
公开(公告)号	US6617177	公开(公告)日	2003-09-09
申请号	US10/231392	申请日	2002-08-28
[标]申请(专利权)人(译)	英特尔公司		
申请(专利权)人(译)	英特尔公司		
当前申请(专利权)人(译)	英特尔公司		
[标]发明人	WINER PAUL		
发明人	WINER, PAUL		
IPC分类号	G02F1/13 G02F1/1341 H01L21/768 H01L21/70 G02F1/1333 H01L21/66 H01L21/44 H01L21/00 H01L21/301		
CPC分类号	G02F1/1309 G02F1/1341 H01L21/76898 G02F1/133351 G02F1/136277 G02F2201/42		
外部链接	Espacenet USPTO		

摘要(译)

一种制造LCOS器件并以晶片级测试它们以识别已知坏的骰子的方法，以便于完成仅已知良好骰子的制造。将晶片级透明电极玻璃临时放置在晶片上，并且通过延伸穿过晶片的填充孔将液晶材料注入LCOS器件腔。在取下玻璃并将晶片分成骰子后，只有好的骰子连接了它们的模具玻璃，重新注入了液晶材料，固定了焊料凸点，并附着了基板。

