



US 20050024847A1

(19) **United States**

(12) **Patent Application Publication**

(10) **Pub. No.: US 2005/0024847 A1**

Ahn et al.

(43) **Pub. Date:**

Feb. 3, 2005

(54) **BACKLIGHT ASSEMBLY AND LIQUID CRYSTAL DISPLAY APPARATUS HAVING THE SAME**

(52) **U.S. Cl. 362/31**

(76) **Inventors: Seung-Ho Ahn, Suwon-si (KR); Hee-June Kwak, Yongin-si (KR)**

(57) **ABSTRACT**

Correspondence Address:
CANTOR COLBURN LLP
55 Griffin Road South
Bloomfield, CT 06002 (US)

A backlight assembly includes a light supplying part and a light guide plate. The light supplying part includes a white light source and a monochromatic light source that generates a monochromatic light. The white light source generates a white light responsive to an electric power provided from exterior to the backlight assembly. The light guide plate is disposed adjacent to a side of the light supplying part. The light guide plate includes a light guiding region where the white light and the monochromatic light are guided into and a peripheral region that surrounds the light guiding region. Therefore, color reproducibility of an LCD apparatus is increased so that an image display quality of the LCD apparatus is improved.

(21) **Appl. No.: 10/909,551**

(22) **Filed: Aug. 2, 2004**

(30) **Foreign Application Priority Data**

Aug. 2, 2003 (KR) 2003-53647

Publication Classification

(51) **Int. Cl.⁷ F21V 7/04**

400

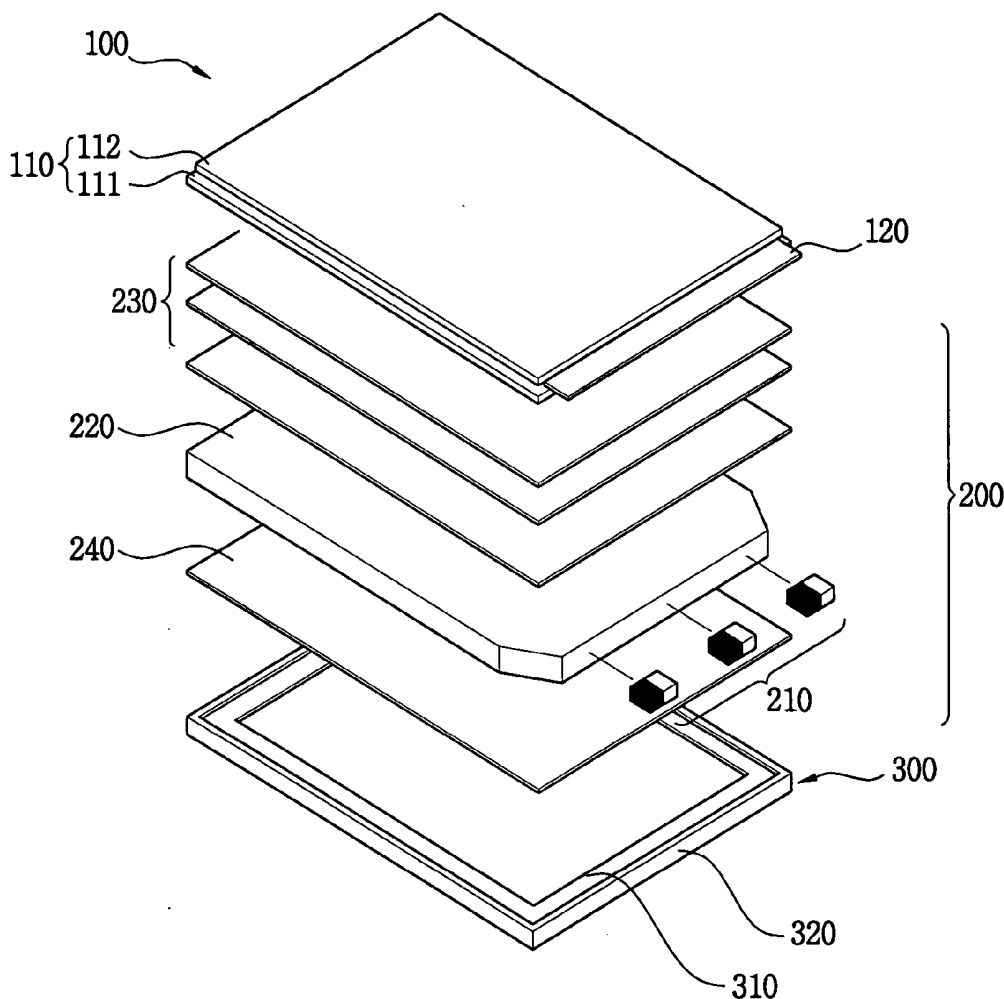

FIG. 1

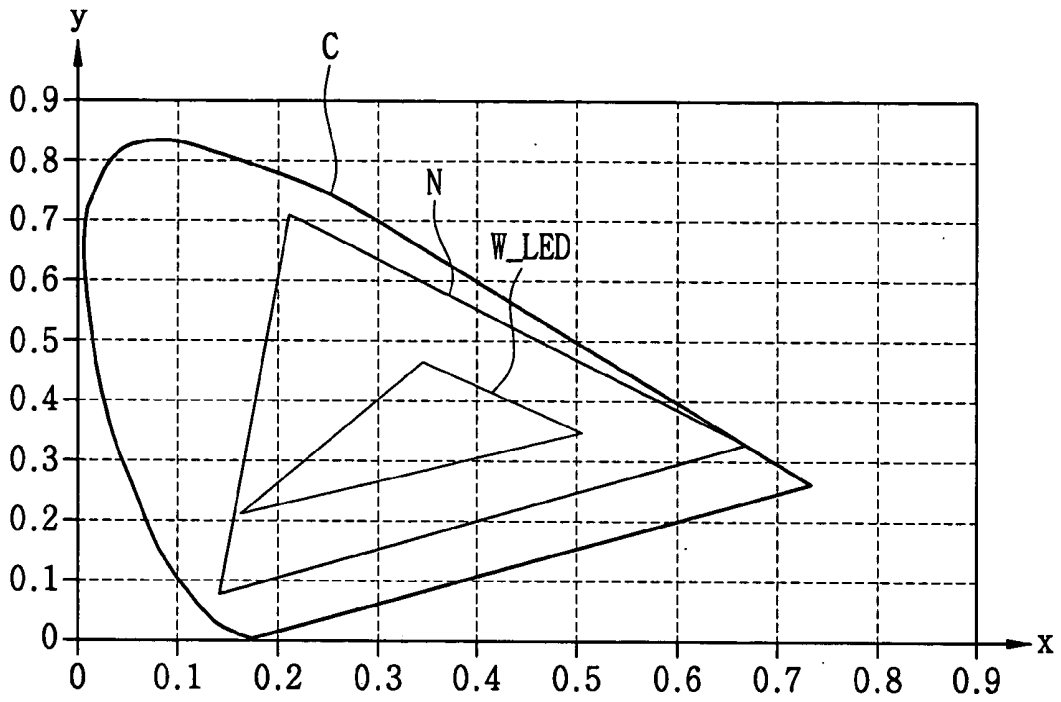

FIG. 2

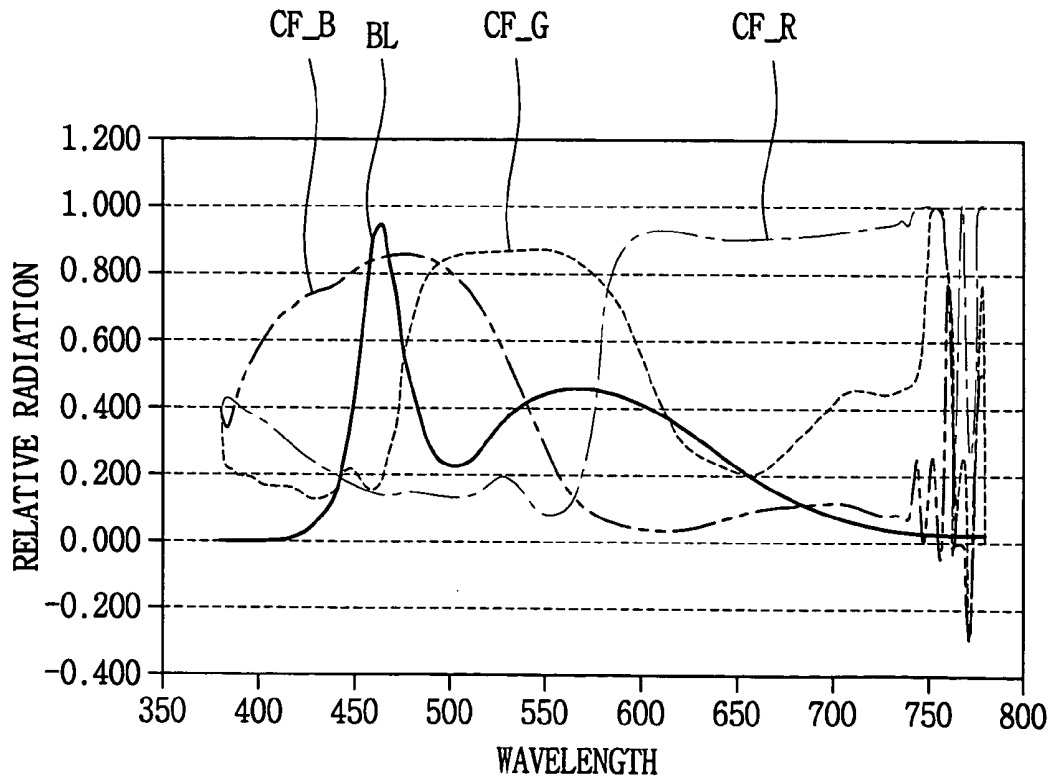

FIG. 3

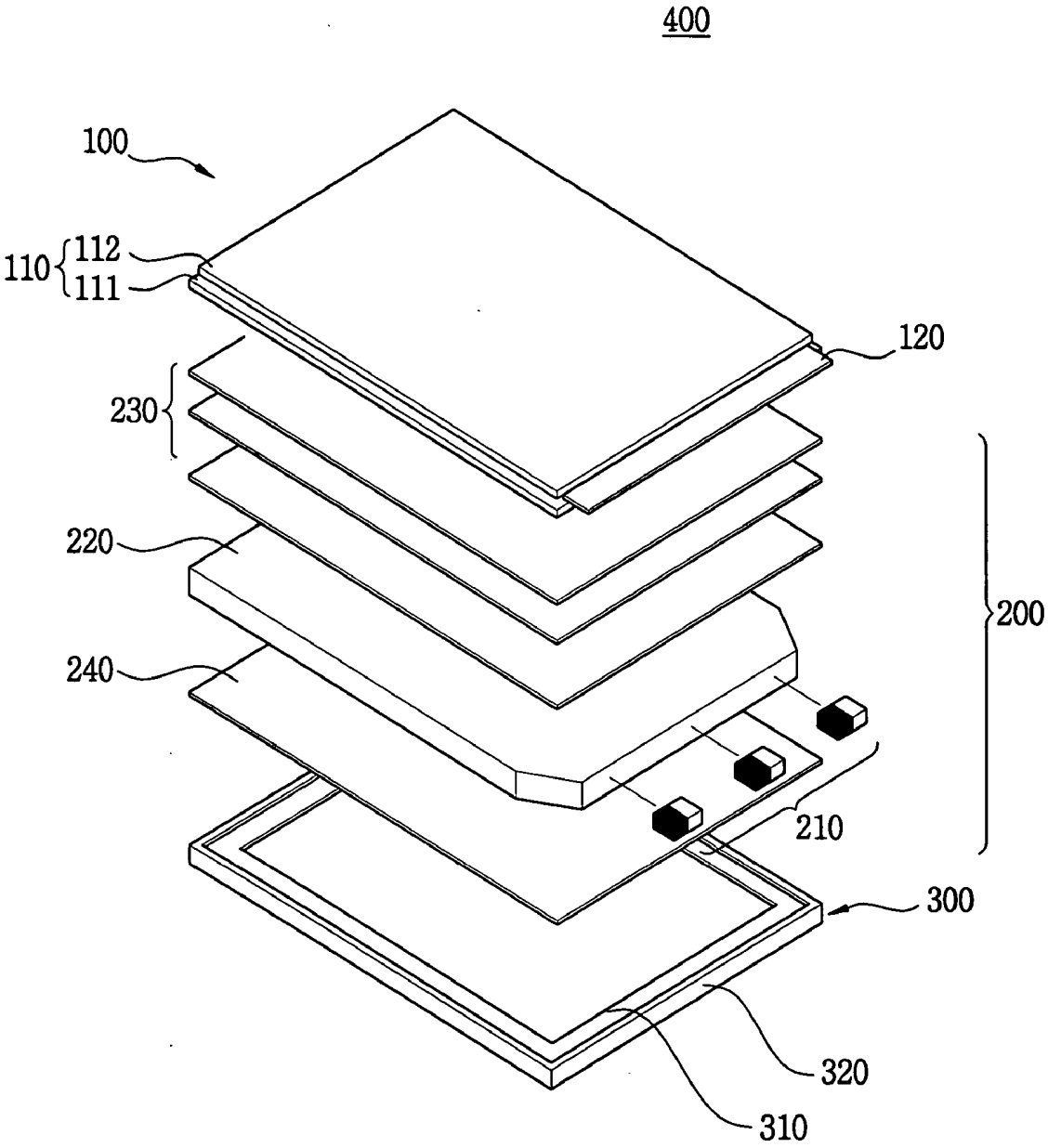

FIG. 4

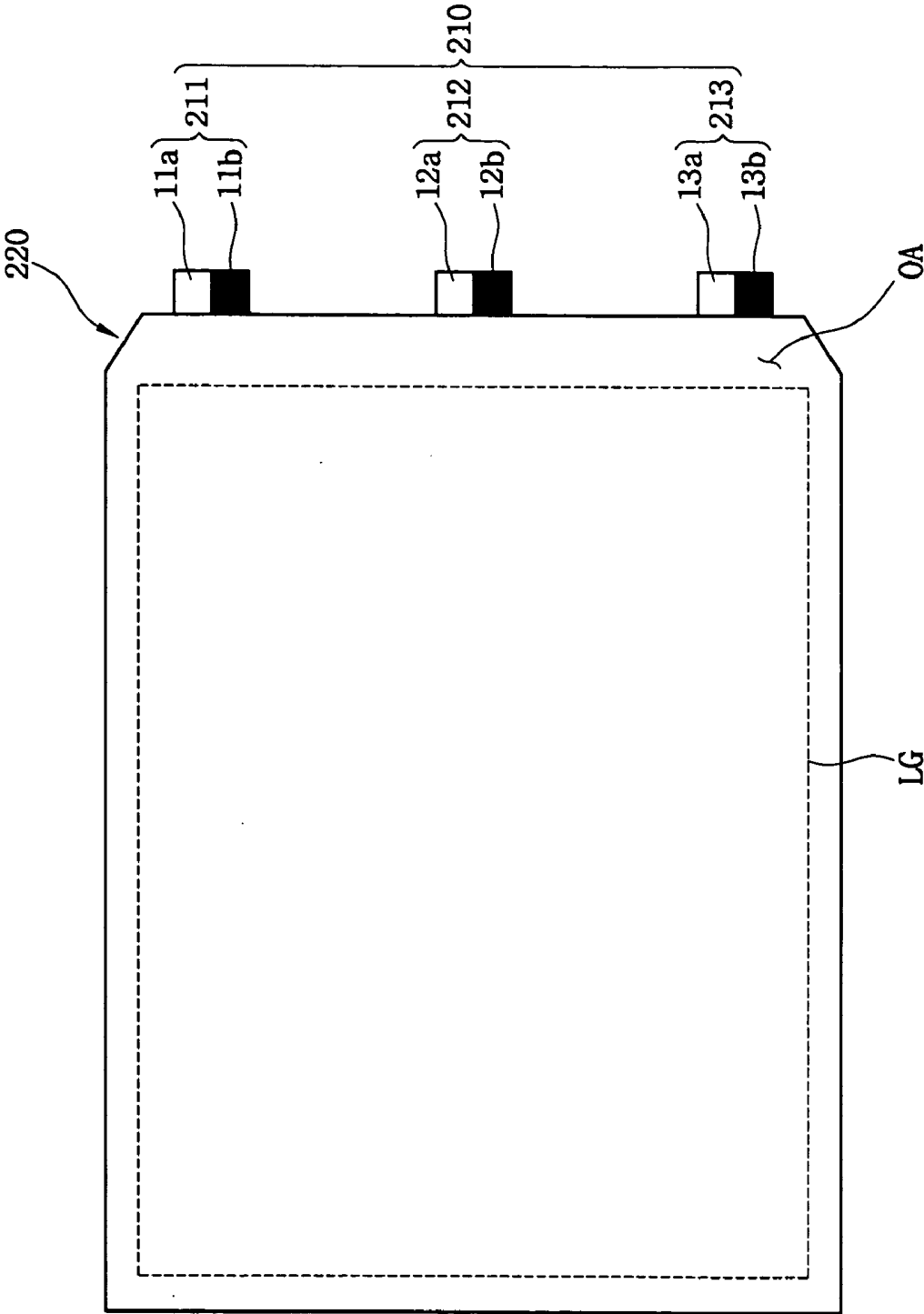

FIG. 5

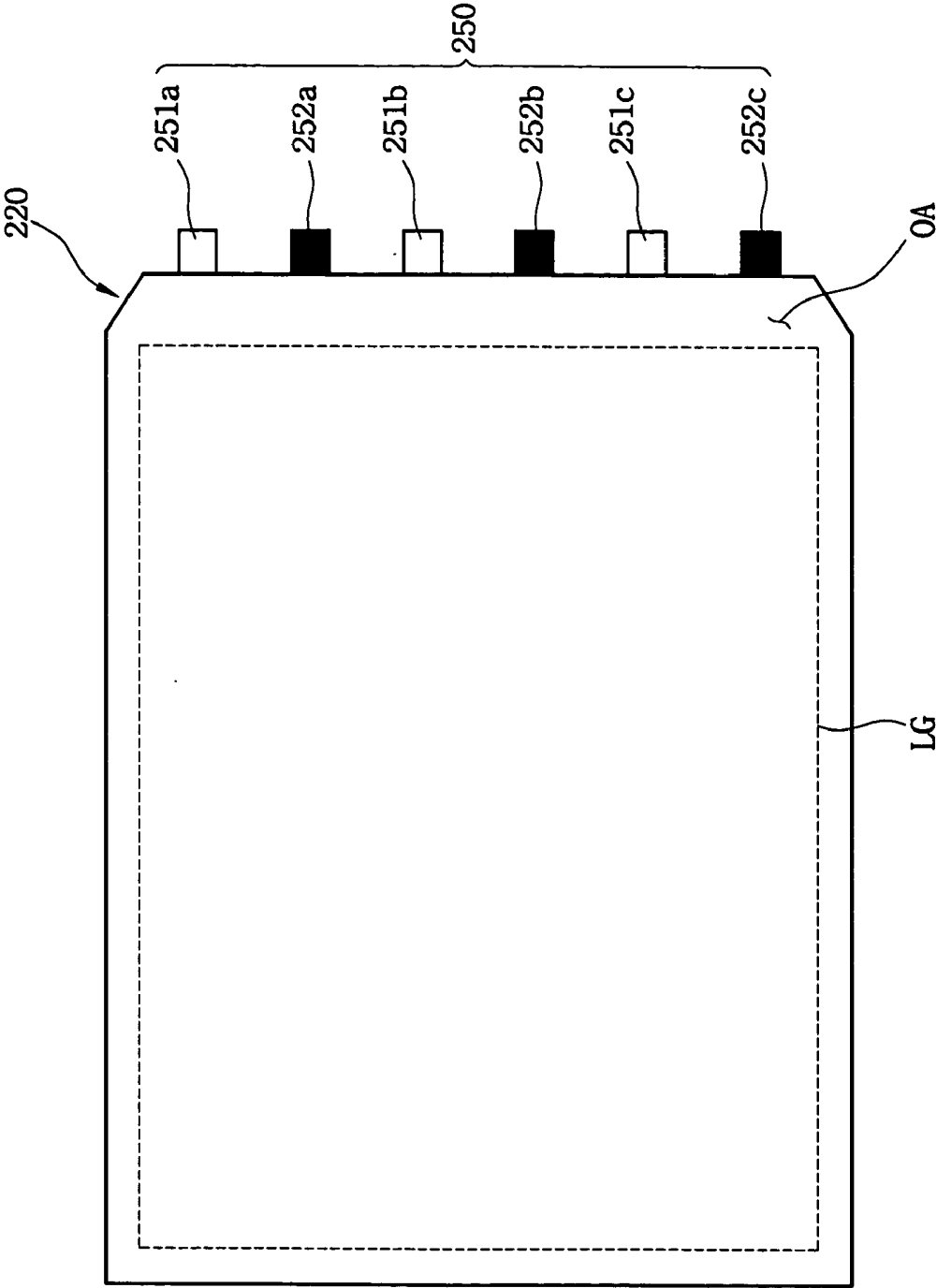

FIG. 6

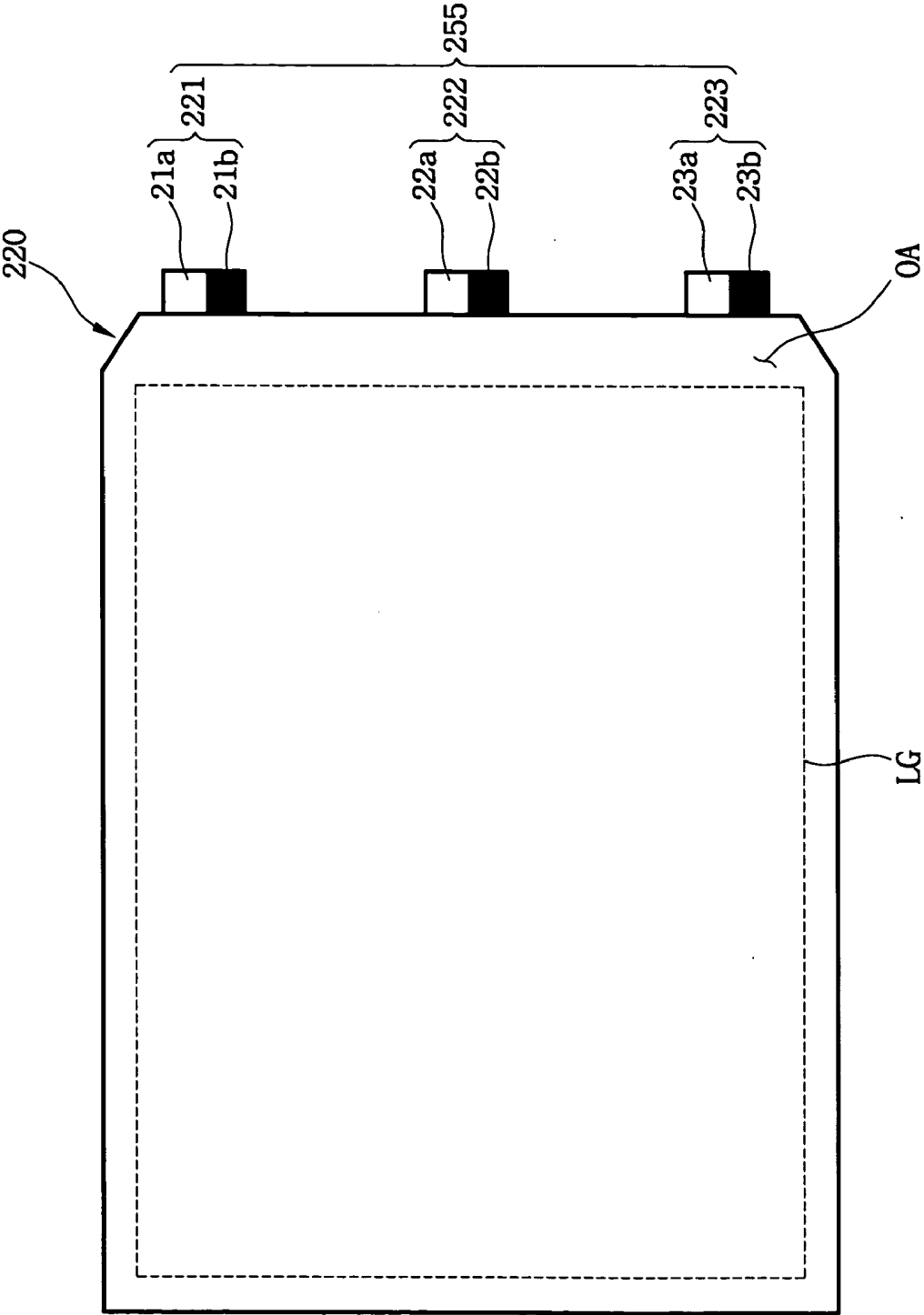
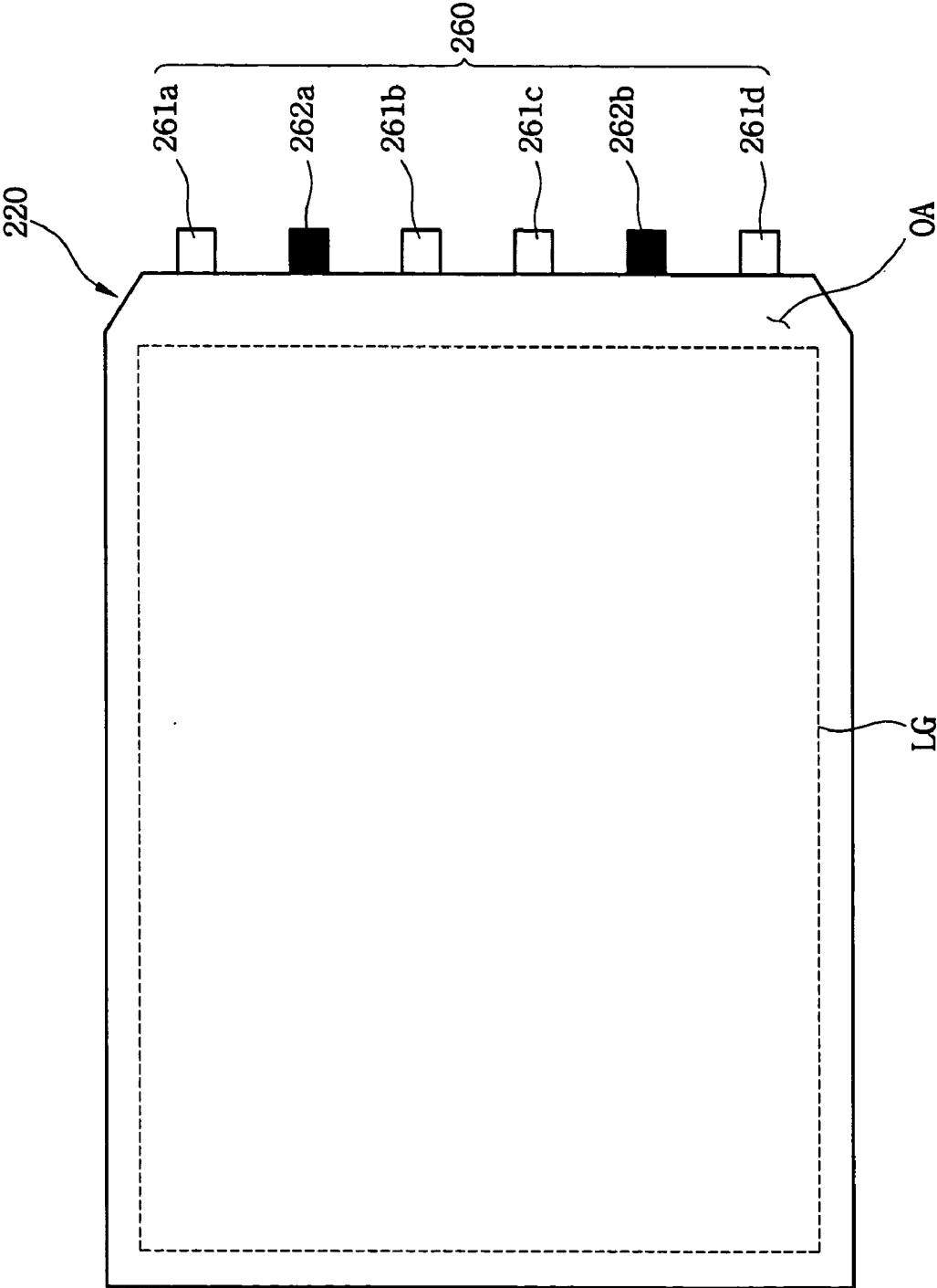

FIG. 7



BACKLIGHT ASSEMBLY AND LIQUID CRYSTAL DISPLAY APPARATUS HAVING THE SAME**CROSS-REFERENCE OF RELATED APPLICATIONS**

[0001] The present application claims priority from Korean Patent Application No. 2003-53647, filed on Aug. 2, 2003, the disclosure of which is hereby incorporated herein by reference in its entirety.

BACKGROUND OF THE INVENTION

[0002] 1. Field of the Invention

[0003] The present invention relates to a backlight assembly and a liquid crystal display (LCD) apparatus having the backlight assembly. More particularly, the present invention relates to a backlight assembly capable of improving color reproducibility to improve an image display quality and an LCD apparatus having the backlight assembly.

[0004] 2. Description of the Related Art

[0005] An LCD apparatus, in general, includes an LCD panel and a backlight assembly. The backlight assembly supplies the LCD panel with a light. The LCD panel displays an image using the light.

[0006] The backlight assembly includes a light source that generates the light. The light source includes a cold cathode fluorescent lamp (CCFL), a light emitting diode (LED), etc.

[0007] A size of the LED is smaller than that of the CCFL. The LED is a point light source. A small LCD apparatus that may be several inches has the LED as the light source.

[0008] The small LCD apparatus includes a white LED that generates a white light. In general, a portion of the white light, which corresponds to a predetermined wavelength, has a lower luminance than a remaining portion of the white light. When the portion of the white light, which corresponds to the predetermined wavelength, has the lower luminance than the remaining portion of the white light, a color reproducibility of the small LCD apparatus is decreased so that an image display quality of the small LCD apparatus is deteriorated.

BRIEF SUMMARY OF THE INVENTION

[0009] The present invention provides a backlight assembly capable of improving an image display quality.

[0010] The present invention also provides a liquid crystal display (LCD) apparatus having the above-mentioned backlight assembly.

[0011] A backlight assembly in accordance with an exemplary embodiment of the present invention includes a light supplying part and a light guide plate. The light supplying part includes a white light source and a monochromatic light source that generates a monochromatic light. The white light source generates a white light responsive to an electric power provided from exterior to the backlight assembly. The light guide plate is disposed adjacent to a side of the light supplying part. The light guide plate includes a light guiding region where the white light and the monochromatic light are guided into and a peripheral region that surrounds the light guiding region.

[0012] An LCD apparatus in accordance with an exemplary embodiment of the present invention includes an LCD panel, a light supplying part and a light guide plate. The liquid crystal display panel displays an image using a white light and a monochromatic light. The light supplying part includes a white light source and a monochromatic light source that generates the monochromatic light. The white light source generates the white light responsive to an electric power provided from exterior to the light supplying part. The light guide plate is disposed adjacent to a side of the light supplying part. The light guide plate includes a light guiding region where the white light and the monochromatic light are guided into and a peripheral region that surrounds the light guiding region.

[0013] Therefore, the backlight assembly includes the white light source and the monochromatic light source. The monochromatic light is a same color light which has the lowest brightness among red, green and blue colors from the white light source. That is, a portion of the light generated from the white light source has lower luminance than a remaining portion of the light generated from the white light source. The monochromatic light source generates a light corresponding to the wavelength having the lower luminance. Therefore, color reproducibility of the LCD apparatus is increased so that the image display quality of the LCD apparatus is improved.

BRIEF DESCRIPTION OF THE DRAWINGS

[0014] The above and other advantages of the present invention will become more apparent by describing in detail exemplary embodiments thereof with reference to the accompanying drawings, in which:

[0015] **FIG. 1** is a chromaticity diagram showing colors of a white light emitting diode (LED);

[0016] **FIG. 2** is a graph showing a relationship between relative radiations and wavelength of lights that pass through red, green and blue color filters and a white light generated from a white LED;

[0017] **FIG. 3** is an exploded perspective view showing an LCD apparatus in accordance with an exemplary embodiment of the present invention;

[0018] **FIG. 4** is a plan view showing a light source shown in **FIG. 3**;

[0019] **FIG. 5** is a plan view showing a light source in accordance with another exemplary embodiment of the present invention;

[0020] **FIG. 6** is a plan view showing a light source in accordance with another exemplary embodiment of the present invention; and

[0021] **FIG. 7** is a plan view showing a light source in accordance with another exemplary embodiment of the present invention.

DESCRIPTION OF THE EMBODIMENTS

[0022] It should be understood that the exemplary embodiments of the present invention described below may be varied modified in many different ways without departing from the inventive principles disclosed herein, and the scope of the present invention is therefore not limited to these

particular following embodiments. Rather, these embodiments are provided so that this disclosure will be through and complete, and will fully convey the concept of the invention to those skilled in the art by way of example and not of limitation.

[0023] Hereinafter, the present invention will be described in detail with reference to the accompanying drawings.

[0024] A liquid crystal display (LCD) apparatus includes a white light emitting diode (LED) that generates a white light. The white LED includes a blue light emitting portion and a vacuum tube. The blue light emitting portion includes a semiconductor compound such as $\text{In}_x\text{Ga}_y\text{Al}_z\text{N}$. A yellow fluorescent material such as $\text{Y}_3\text{Al}_5\text{O}_{12}:\text{Ce}$ is coated on the vacuum tube. Table 1 represents chromaticity coordinates of red, green and blue portions of a white light generated from the white LED.

TABLE 1

Color	Coordinates		
	x	y	z
Red	5.05E-01	3.50E-01	1.45E-01
Green	3.44E-01	4.66E-01	1.90E-01
Blue	1.63E-01	2.09E-01	6.28E-01

[0025] FIG. 1 is a chromaticity diagram showing colors of a white light emitting diode (LED). The chromaticity diagram W_LED of the white LED is compared with a chromaticity diagram of Commission International De L'eclairage (CIE) and a chromaticity diagram of National Television System Committee (NTSC).

[0026] Referring to Table 1 and FIG. 1, color coordinates of the red, green and blue portions of the white light generated from the white LED are (5.05E-01, 3.50E-01, 1.45E-01), (3.44E-01, 4.66E-01, 1.90E-01) and (1.63E-01, 2.09E-01, 6.28E-01), respectively. The color coordinates of the red, green and blue portions of the white light generated from the white LED form a triangle. A color disposed in the triangle of the white LED may be displayed using the white LED.

[0027] Color coordinates of red, green and blue portions of the chromaticity diagram C of the CIE are (5.05E-01, 3.50E-01, 1.45E-01), (3.44E-01, 4.66E-01, 1.90E-01) and (1.63E-01, 2.09E-01, 6.28E-01), respectively.

[0028] Color coordinates of red, green and blue portions of the chromaticity diagram N of the NTSC are (6.700E-01, 3.300E-01), (2.100E-01, 7.100E-01) and (1.400E-01, 0.800E-01), respectively.

[0029] The chromaticity diagram C of the CIE has a horseshoe shape. The chromaticity diagram N of the NTSC has a triangular shape that is smaller than the horseshoe shape of the CIE. Therefore, the chromaticity diagram C of the CIE has wider range than the chromaticity diagram N of the NTSC so that the chromaticity diagram C of the CIE includes more various colors than the chromaticity diagram N of the NTSC.

[0030] The chromaticity diagram W_LED of the white LED has the triangular shape that is smaller than the chromaticity diagram N of the NTSC. Therefore, the chromaticity diagram W_LED of the white LED has narrower range than the chromaticity diagram N of the NTSC so that the chromaticity diagram W_LED of the white LED includes simpler colors than the chromaticity diagram N of the NTSC. In particular, an amount of the red portion of the white light generated from the white LED is smaller than that of the chromaticity diagram N of the NTSC. Therefore, the amount of the red portion of the white light generated from the white LED is smaller than that of the green portion or the blue portion of the white light generated from the white LED.

[0031] FIG. 2 is a graph showing a relationship between relative radiations and wavelengths of lights that pass through red, green and blue color filters and a white light generated from a white LED.

[0032] Referring to FIG. 2, the wavelengths of the lights that pass through the red, green and blue color filters CF_R, CF_G and CF_B are about 600 nm to 750 nm, about 500 nm to 600 nm and about 400 nm to 500 nm, respectively.

[0033] A relative radiation of the blue portion of the light generated from the white LED (BL) is smaller than a relative radiation of the red portion of the light generated from the white LED (BL). In addition, a relative radiation of the green portion of the light generated from the white LED (BL) is smaller than a relative radiation of the red portion of the light generated from the white LED (BL). The red portion of the light generated from the white LED (BL) has the wavelength of about 600 nm to 750 nm. The blue portion of the light generated from the white LED (BL) has the wavelength of about 450 nm to 470 nm. The green portion of the light generated from the white LED (BL) has the wavelength of about 500 nm to 600 nm. The red portion of the light generated from the white LED (BL) has the wavelength of about 600 nm to 750 nm.

[0034] A red luminance of the LCD apparatus is substantially the same as a summation of the relative radiation of the light that passes through the red color filter and the relative radiation of the red portion of the white light generated from the white LED. A green luminance of the LCD apparatus is substantially the same as a summation of the relative radiation of the light that passes through the green color filter and the relative radiation of the green portion of the white light generated from the white LED. A blue luminance of the LCD apparatus is substantially the same as a summation of the relative radiation of the light that passes through the blue color filter and the relative radiation of the blue portion of the white light generated from the white LED.

[0035] The amount of the red portion of the white light generated from the white LED is smaller than that of the green portion or the blue portion of the white light generated from the white LED so that the red luminance of the LCD apparatus is smaller than the green luminance or the blue luminance of the LCD apparatus. Therefore, the red luminance of the LCD apparatus is decreased so that a color reproducibility of the LCD apparatus is decreased, thereby deteriorating an image display quality of the LCD apparatus.

[0036] FIG. 3 is an exploded perspective view showing an LCD apparatus in accordance with an exemplary embodiment of the present invention.

[0037] Referring to FIG. 3, the LCD apparatus 400 includes an LCD panel assembly 100, a backlight assembly

200 and a mold frame **300**. The backlight assembly **200** generates a light. The LCD panel assembly **100** displays an image using the light. The mold frame **300** receives the LCD panel assembly **100** and the backlight assembly **200**.

[0038] The LCD panel assembly **100** includes an LCD panel **110** and a flexible circuit board **120**. The LCD panel **110** receives an image signal that is provided from exterior through the flexible circuit board **120** to display the image.

[0039] The LCD panel **110** includes a thin film transistor (TFT) substrate **111**, a color filter substrate **112** and a liquid crystal layer (not shown). The color filter substrate **112** corresponds to the TFT substrate **111**. The liquid crystal layer (not shown) is disposed between the TFT substrate **111** and the color filter substrate **112**.

[0040] The TFT substrate **111** includes a first transparent plate and a switching element. The switching element is formed on the first transparent plate. The TFT substrate **111** may include a plurality of the switching elements. The switching element includes a TFT. The color filter substrate **112** includes a second transparent plate and red, green and blue color filters. The red, green and blue color filters are formed on the second transparent plate to display the image based on the light. The red, green and blue color filters may be formed through a coating process, a deposition process, etc.

[0041] A data driving circuit (not shown) is formed in a source region of the TFT substrate **111**. The data driving circuit (not shown) applies a data signal to the switching element. Alternatively, a plurality of the data driving circuits may be formed in the source region of the TFT substrate **111**. A gate driving circuit (not shown) is formed in a gate region of the TFT substrate **111**. The gate driving circuit (not shown) applies a gate signal to the switching element. Alternatively, a plurality of the gate driving circuits may be formed in the gate region of the TFT substrate **111**. The data and gate driving circuits output driving signals for driving the switching element and timing signals for controlling the driving signals based on the image signal.

[0042] The flexible circuit board **120** is formed on the source region of the TFT substrate **111**. The flexible circuit board **120** is electrically connected to the data and gate driving circuits to apply the image signal to the data and gate driving circuits.

[0043] The backlight assembly **200** includes a light source **210**, a light guide plate **220**, optical sheets **230** and a reflecting plate **240**. The light source **210** generates a light. The light guide plate **220** guides the light generated from the light source **210** into the LCD panel **110**. The optical sheets **230** uniformize a luminance of the light that passes through the light guide plate **220**. A portion of the light that is leaked from the light guide plate **220** is reflected from the reflecting plate **240** so that the reflected light is guided into the light guide plate **220**. Alternatively, the backlight assembly **200** may include a plurality of the light sources.

[0044] The light source **210** is disposed adjacent a side of the light guide plate **220**. The light source **210** includes a plurality of light emitting diodes (LED). In this exemplary embodiment, the light source **210** includes a white LED and a red LED. Alternatively, the light source **210** may include a plurality of the white LEDs and a plurality of the red LEDs. The white and red LEDs are disposed alternately.

Alternatively, the light source **210** may include the white LED and a green LED. The light source **210** may also include the white LED and a blue LED. The light source **210** may also include the white LED and a yellow LED.

[0045] The light guide plate **220** guides the light generated from the light source **210** into a display region of the LCD panel **110**. Alternatively, the light guide plate **220** may include light guiding patterns (not shown). The light guiding patterns (not shown) are formed in a light guiding region that corresponds to the display region.

[0046] The optical sheets **230** are disposed between the light guide plate **220** and the LCD panel **110**. The optical sheets **230** uniformize the luminance of the light that passes through the light guide plate **220**.

[0047] The reflecting plate **240** is disposed under the light guide plate **220**. The portion of the light that is leaked from the light guide plate **220** is reflected from the reflecting plate **240** so that the portion of the light is guided into the light guide plate **220**, thereby improving the luminance of the LCD apparatus.

[0048] The backlight assembly **200** and the LCD panel **110** are received in the mold frame **300**. The mold frame **300** includes a bottom plate **310** and a sidewall **320**. The bottom plate **310** has an opening that is disposed at a central portion of the bottom plate **310**. The sidewall **320** is protruded from a side of the bottom plate **310**. The backlight assembly **200** is disposed on the bottom plate **310**, and the LCD panel **110** is disposed on the backlight assembly **200**. The flexible circuit board **120** is bent along the sidewall **320** of the mold frame **300**.

[0049] FIG. 4 is a plan view showing a light source shown in FIG. 3.

[0050] Referring to FIG. 4, the light guide plate **220** includes the light guiding region LG and a peripheral region OA. The peripheral region OA surrounds the light guiding region LG. The light source **210** is spaced apart from the light guiding region LG by the peripheral region OA.

[0051] When the light is incident into an upper side of the light guide plate **220**, a portion of the light is concentrated on a portion of the light guide plate **220** adjacent to the upper side to form a bright line in the peripheral region OA. When the bright line is disposed in the peripheral region OA, the light guide region LG has more uniform luminance than the peripheral region OA, thereby uniformizing the luminance of the backlight assembly **400**.

[0052] Two corners of the light guide plate **220**, which are disposed adjacent to the light source **210**, are chamfered so that portions of the light that is guided into the corners are reflected from the chamfered corners. Therefore, the reflected light is guided into the light guide region LG to improve the luminance of the backlight assembly **400**.

[0053] The light source **210** includes a first light emitting unit **211**, a second light emitting unit **212** and a third light emitting unit **213**. The first, second and third light emitting units **211**, **212** and **213** are spaced apart from one another.

[0054] The first light emitting unit **211** includes a first white LED **11a** and a first red LED **11b**. The second light emitting unit **212** includes a second white LED **12a** and a

second red LED **12b**. The third light emitting unit **213** includes a third white LED **13a** and a third red LED **13b**.

[0055] Each of the first, second and third white LEDs **11a**, **12a** and **13a** generates a white light responsive to a voltage that is provided from exterior to the light source **210**. Each of the first, second and third white LEDs **11a**, **12a** and **13a** includes a blue light emitting portion and a vacuum tube. The blue light emitting portion includes a semiconductor compound such as $\text{In}_i\text{Ga}_j\text{Al}_k\text{N}$. A yellow fluorescent material such as $\text{Y}_3\text{Al}_5\text{O}_{12}:\text{Ce}$ is coated on the vacuum tube.

[0056] Each of the first, second and third red LEDs **11b**, **12b** and **13b** generates a red light responsive to the voltage applied thereto.

[0057] In this exemplary embodiment, the LCD apparatus **400** includes three white LEDs **11a**, **12a** and **13a** and three red LEDs **11b**, **12b** and **13b**. Alternatively, number of the LEDs may be changed in accordance with a size of the LCD panel **110**. Number of the light emitting units may also be varied in accordance with the number of the LEDs. The first, second and third white LEDs **11a**, **12a** and **13a** and the first, second and third red LEDs **11b**, **12b** and **13b** are disposed alternately. Therefore, portions of lights generated from the first, second and third white LEDs **11a**, **12a** and **13a** and the first, second and third red LEDs **11b**, **12b** and **13b** are mixed with one another so that the light having the mixed portions of the lights is guided into the light guide plate **220**.

[0058] The voltages applied to the LEDs are adjusted so that relative luminances of red, green and blue portions of the light are controlled. A ratio of the relative luminances of the red, green and blue portions of the light may be about 3:6:1.

[0059] In this exemplary embodiment, the LCD apparatus **400** includes the white LEDs and the red LEDs. Each of the red LEDs is a monochromatic LED. A color of the monochromatic LED is determined by the white light that is generated from each of the white LEDs. When an amount of a green portion of the white light generated from the white LED is smaller than that of a red portion or a blue portion of the white light generated from the white LED, the light source **210** includes the white LEDs and green LEDs. In addition, when an amount of the blue portion of the white light generated from the white LED is smaller than that of the red portion or the green portion of the white light generated from the white LED, the light source **210** includes the white LEDs and blue LEDs.

[0060] In this exemplary embodiment, the light source **210** includes the white LEDs and the red LEDs, and the white LEDs and the red LEDs are disposed alternately. Therefore, the red luminance of the LCD apparatus **400** is increased so that the color reproducibility of the LCD apparatus **400** is improved and the LCD apparatus **400** may display a primary color, thereby improving the image display quality of the LCD apparatus **400**.

[0061] FIG. 5 is a plan view showing a light source in accordance with another exemplary embodiment of the present invention. The liquid crystal display apparatus of FIG. 5 is same as in FIGS. 3 and 4 except for a light source. Thus, the same reference numerals will be used to refer to the same or like parts as those described in FIGS. 3 and 4 and any further explanation will be omitted.

[0062] Referring to FIG. 5, the light source **250** is disposed adjacent to a side of a light guide plate **220**. The light source **250** includes a first white LED **251a**, a second white LED **251b**, a third white LED **251c**, a first red LED **252a**, a second red LED **252b** and a third red LED **252c**.

[0063] Each of the first, second and third white LEDs **251a**, **251b** and **251c** generates a white light responsive to a voltage that is provided from exterior to the light source **250**. Each of the first, second and third white LEDs **251a**, **251b** and **251c** includes a blue light emitting portion and a vacuum tube. The blue light emitting portion includes a semiconductor compound such as $\text{In}_i\text{Ga}_j\text{Al}_k\text{N}$. A yellow fluorescent material such as $\text{Y}_3\text{Al}_5\text{O}_{12}:\text{Ce}$ is coated on the vacuum tube.

[0064] Each of the first, second and third red LEDs **252a**, **252b** and **252c** generates a red light responsive to the voltage.

[0065] In this exemplary embodiment, the light source **250** includes three white LEDs **251a**, **251b** and **251c** and three red LEDs **252a**, **252b** and **252c**. Alternatively, number of the LEDs may be varied in accordance with a size of the LCD panel **110**. The first, second and third white LEDs **251a**, **251b** and **251c** and the first, second and third red LEDs **252a**, **252b** and **252c** are disposed alternately adjacent to a side of the light guide plate **220**.

[0066] Therefore, the first red LED **252a** is disposed between the first and second white LEDs **251a** and **251b**. The second red LED **252b** is disposed between the second and third white LEDs **251b** and **251c**. The third white LED **251c** is disposed between the second red LED **252b** and the third red LED **252c**.

[0067] Portions of lights generated from the first, second and third white LEDs **251a**, **251b** and **251c** and the first, second and third red LEDs **252a**, **252b** and **252c** are mixed with one another so that a light that has the mixed portions of the lights is guided into the light guide plate **220**.

[0068] In this exemplary embodiment, the light source **250** includes the white LEDs and the red LEDs. Each of the red LEDs is the monochromatic LED. A color of the monochromatic LED is determined by the white light that is generated from each of the white LEDs. When an amount of a green portion of the white light generated from the white LED is smaller than that of a red portion or a blue portion of the white light generated from the white LED, the light source **250** includes the white LEDs and green LEDs. In addition, when an amount of the blue portion of the white light generated from the white LED is smaller than that of the red portion or the green portion of the white light generated from the white LED, the light source **250** includes the white LEDs and blue LEDs.

[0069] FIG. 6 is a plan view showing a light source in accordance with another exemplary embodiment of the present invention. A liquid crystal display apparatus of FIG. 6 is same as in FIGS. 3 and 4 except for a light source. Thus, the same reference numerals will be used to refer to the same or like parts as those described in FIGS. 3 and 4 and any further explanation will be omitted.

[0070] Referring to FIG. 6, the light source **255** includes a first light emitting unit **221**, a second light emitting unit **222** and a third light emitting unit **223**. The first light emitting unit **221** includes a first white LED **21a** and a first

red LED **21b**. The second light emitting unit **222** includes a second white LED **22a** and a second red LED **22b**. The third light emitting unit **223** includes a third white LED **23a** and a third red LED **23b**.

[0071] A size of each of the first, second and third white LEDs **21a**, **22a** and **23a** is larger than that of each of the first, second and third red LEDs **21b**, **22b** and **23b**. In addition, an amount of a voltage applied to each of the first, second and third white LEDs **21a**, **22a** and **23a** is larger than that of a voltage applied to each of the first, second and third red LEDs **21b**, **22b** and **23b**. Therefore, a luminance of a light generated from each of the first, second and third white LEDs **21a**, **22a** and **23a** is larger than that of a light generated from each of the first, second and third red LEDs **21b**, **22b** and **23b**.

[0072] According to this exemplary embodiment, the size of each of the LEDs and the voltage applied to each of the LEDs are adjusted to control the luminance of the light generated from each of the LEDs.

[0073] FIG. 7 is a plan view showing a light source in accordance with another exemplary embodiment of the present invention. The liquid crystal display apparatus of FIG. 7 is same as in FIGS. 3 and 4 except for a light source. Thus, the same reference numerals will be used to refer to the same or like parts as those described in FIGS. 3 and 4 and any further explanation will be omitted.

[0074] Referring to FIG. 7, the light source **260** is disposed adjacent to a side of a light guide plate **220**. The light source **260** includes a first white LED **261a**, a second white LED **261b**, a third white LED **261c**, a fourth white LED **261d**, a first red LED **262a** and a second red LED **262b**.

[0075] The first red LED **262a** is disposed between the first and second white LEDs **261a** and **261b**. The second red LED **262b** is disposed between the third and fourth white LEDs **261c** and **261d**. The second white LED **261b** is disposed adjacent to the third white LED **261c**.

[0076] Portions of lights generated from the first, second, third and fourth white LEDs **261a**, **261b**, **261c** and **261d**, the first red LED **262a** and the second red LED **262b** are mixed with one another so that a light that has the mixed portions of the lights is guided into the light guide plate **220**.

[0077] According to this exemplary embodiment, number of the white LEDs **261a**, **261b**, **261c** and **261d** and number of the red LEDs **262a** and **262b** are adjusted to improve color reproducibility of the LCD apparatus.

[0078] According to the present invention, the LCD apparatus includes the backlight assembly having the white light source and the monochromatic light source. The monochromatic light source generates a light corresponding to the wavelength having a lower luminance. Therefore, color reproducibility of the LCD apparatus is increased so that the image display quality of the LCD apparatus is improved.

[0079] This invention has been described with reference to the exemplary embodiments. It is evident, however, that many alternative modifications and variations will be appar-

ent to those having skill in the art in light of the foregoing description. Accordingly, the present invention embraces all such alternative modifications and variations as fall within the spirit and scope of the appended claims.

What is claimed is:

1. A backlight assembly comprising:

a light supplying part including a white light source generating white light and a monochromatic light source generating monochromatic light responsive to electric power provided from exterior to the backlight assembly; and

a light guide plate disposed adjacent to a side of the light supplying part, the light guide plate including a light guiding region where the white light and the monochromatic light are guided into and a peripheral region that surrounds the light guiding region.

2. The backlight assembly of claim 1, wherein the light supplying part comprises a light emitting unit, the light emitting unit having the white and monochromatic light sources together.

3. The backlight assembly of claim 2, wherein the light supplying part further comprises one or more light emitting units spaced apart from one another.

4. The backlight assembly of claim 2, wherein an amount of the white light is larger than an amount of the monochromatic light.

5. The backlight assembly of claim 1, wherein the light supplying part comprises a plurality of the white light sources and a plurality of the monochromatic light sources, and the white light sources and the monochromatic light sources are disposed alternately.

6. The backlight assembly of claim 5, wherein the white light sources and the monochromatic light sources are spaced apart from one another.

7. The backlight assembly of claim 5, wherein a number of the white light sources is equal to a number of the monochromatic light sources.

8. The backlight assembly of claim 5, wherein a number of the white light sources is larger than a number of the monochromatic light sources.

9. The backlight assembly of claim 1, wherein a corner disposed in the peripheral region adjacent to the light supplying unit is chamfered.

10. The backlight assembly of claim 1, wherein the monochromatic light is a same color light which has the lowest brightness among red, green and blue colors from the white light source.

11. The backlight assembly of claim 10, wherein the monochromatic light is one of the red, green or blue color lights.

12. The backlight assembly of claim 1, wherein the light source comprises a light emitting diode.

13. A liquid crystal display apparatus comprising:

a light supplying part including a white light source generating white light and a monochromatic light source generating monochromatic light responsive to electric power provided from exterior to the light supplying part;

a light guide plate disposed adjacent to a side of the light supplying part, the light guide plate including a light guiding region where the white light and the mono-

chromatic light are guided into and a peripheral region that surrounds the light guiding region; and

a liquid crystal display panel displaying an image using the white light and the monochromatic light.

14. The liquid crystal display apparatus of claim 13, wherein the light supplying part comprises a light emitting unit, the light emitting unit having the white and monochromatic light sources together.

15. The liquid crystal display apparatus of claim 14, wherein the light supplying part further comprises one or more light emitting units spaced apart from one another.

16. The liquid crystal display apparatus of claim 13, wherein the light supplying part comprises a plurality of the white light sources and a plurality of the monochromatic light sources, and the white light sources and the monochromatic light sources are disposed alternately.

17. The liquid crystal display apparatus of claim 16, wherein the white light sources and the monochromatic light sources are spaced apart from one another.

18. The liquid crystal display apparatus of claim 13, wherein a corner disposed in the peripheral region adjacent to the light supplying unit is chamfered.

19. The backlight assembly of claim 13, wherein the monochromatic light has the same color light that is lowest brightness in red, green and blue color lights from the white light source.

20. The backlight assembly of claim 13, wherein the light source comprises a light emitting diode.

* * * * *

专利名称(译)	背光组件和具有该背光组件的液晶显示装置		
公开(公告)号	US20050024847A1	公开(公告)日	2005-02-03
申请号	US10/909551	申请日	2004-08-02
[标]申请(专利权)人(译)	安承HO KWAK HEE JUNE		
申请(专利权)人(译)	安承HO KWAK HEE六月		
当前申请(专利权)人(译)	三星DISPLAY CO. , LTD.		
[标]发明人	AHN SEUNG HO KWAK HEE JUNE		
发明人	AHN, SEUNG-HO KWAK, HEE-JUNE		
IPC分类号	G02F1/13357 F21V8/00 F21Y101/02 F21V7/04		
CPC分类号	G02B6/0068		
优先权	1020030053647 2003-08-02 KR		
其他公开文献	US7241040		
外部链接	Espacenet USPTO		

摘要(译)

背光组件包括光供应部分和导光板。光供应部分包括白光源和产生单色光的单色光源。白光源响应于从外部到背光组件提供的电力而产生白光。导光板邻近光供应部分的一侧设置。导光板包括导入白光和单色光的导光区域和围绕导光区域的周边区域。因此，增加了LCD装置的颜色再现性，从而提高了LCD装置的图像显示质量。

