



(19) **United States**

(12) **Patent Application Publication**
Yamauchi et al.

(10) **Pub. No.: US 2004/0109112 A1**

(43) **Pub. Date: Jun. 10, 2004**

(54) **LIQUID CRYSTAL DISPLAY DEVICE**

Publication Classification

(76) Inventors: **Naofumi Yamauchi**, Chiba-shi (JP);
Makoto Kurihara, Chiba-shi (JP)

(51) **Int. Cl.⁷** **G02F 1/1335**
(52) **U.S. Cl.** **349/113**

Correspondence Address:
ADAMS & WILKS
31st Floor
50 Broadway
New York, NY 10004 (US)

(57) **ABSTRACT**

To realize at low cost a liquid crystal display device which is thin and in which display on a single liquid crystal panel can be viewed in both ways, from the front and from the back. The liquid crystal display device includes a liquid crystal panel in which a liquid crystal layer is interposed between opposing substrates, and a polarizer and a reflection-polarizing plate provided so as to interpose the liquid crystal panel therebetween. The reflection axis of the reflection-polarizing plate is set in the same direction as a polarization direction of light that exits the liquid crystal panel after its polarization direction is changed in the liquid crystal layer, or a polarization direction of light that exits the liquid crystal panel without being changed in polarization direction in the liquid crystal layer. Due to this arrangement, a liquid crystal display device can be provided which is thin and capable of displaying on both the front side and the back side.

(21) Appl. No.: **10/634,450**

(22) Filed: **Aug. 5, 2003**

(30) **Foreign Application Priority Data**

Aug. 9, 2002 (JP) 2002-233372
Jul. 30, 2003 (JP) 2003-203903

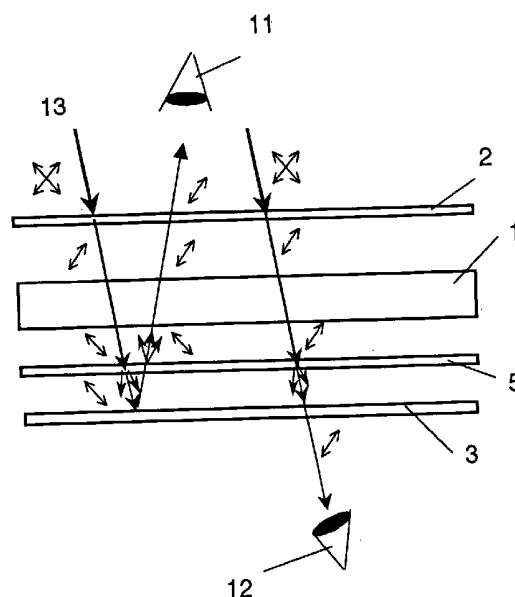
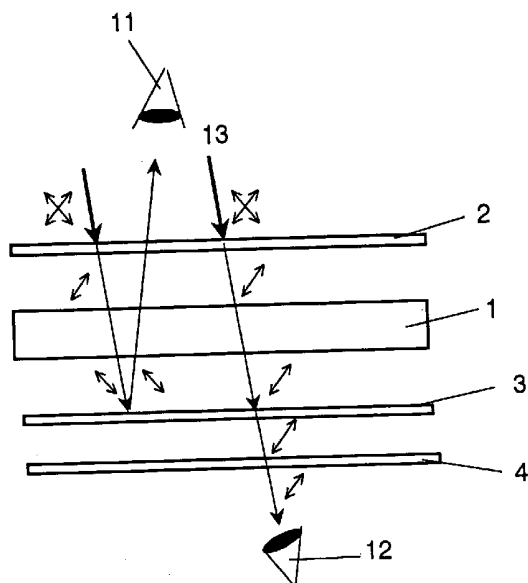

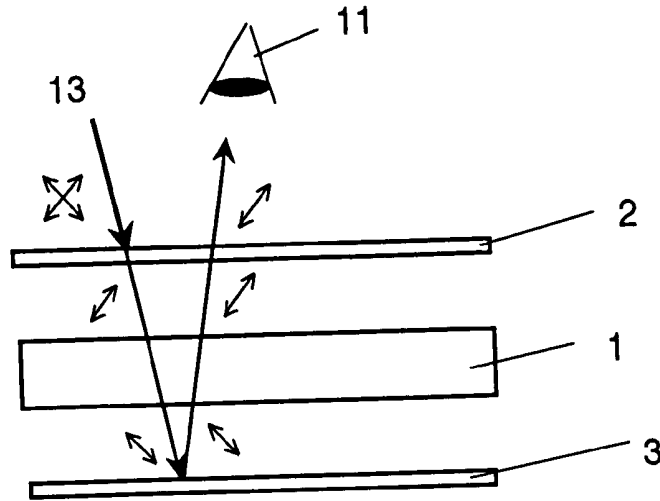

Fig. 1A

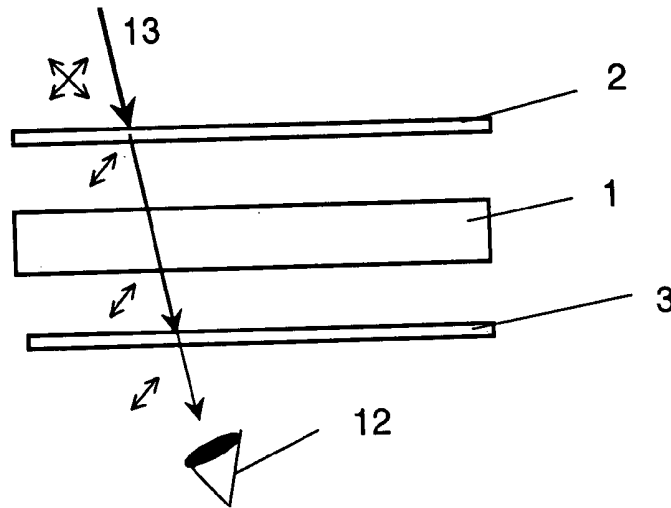

Fig. 1B

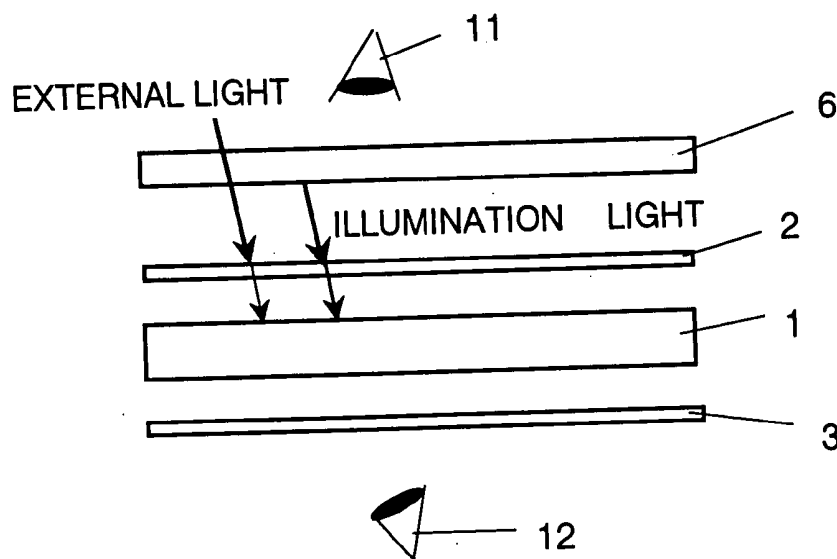

Fig. 2

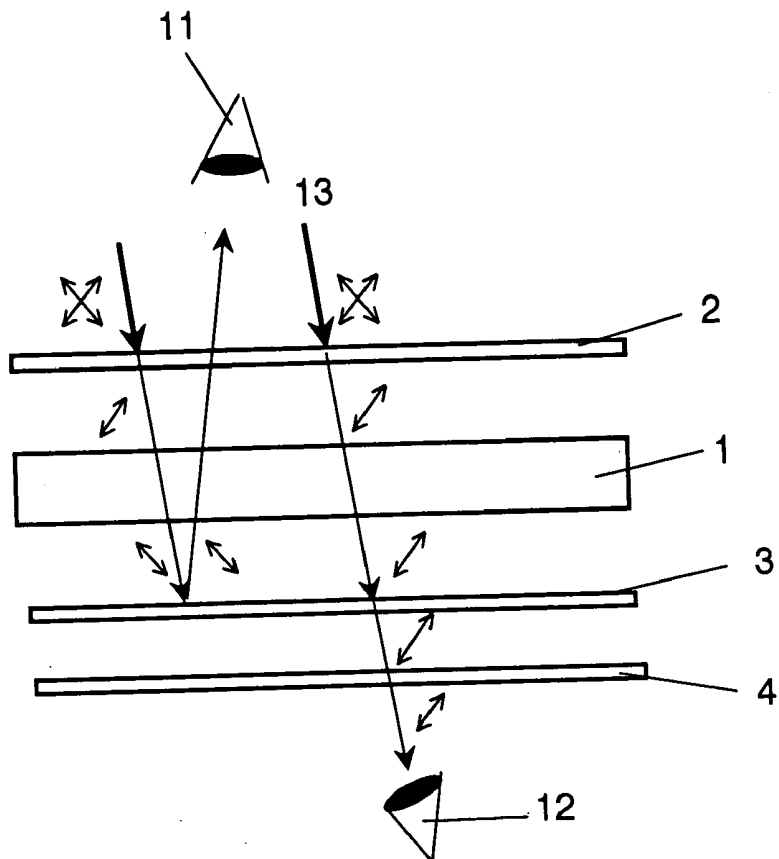

Fig. 3

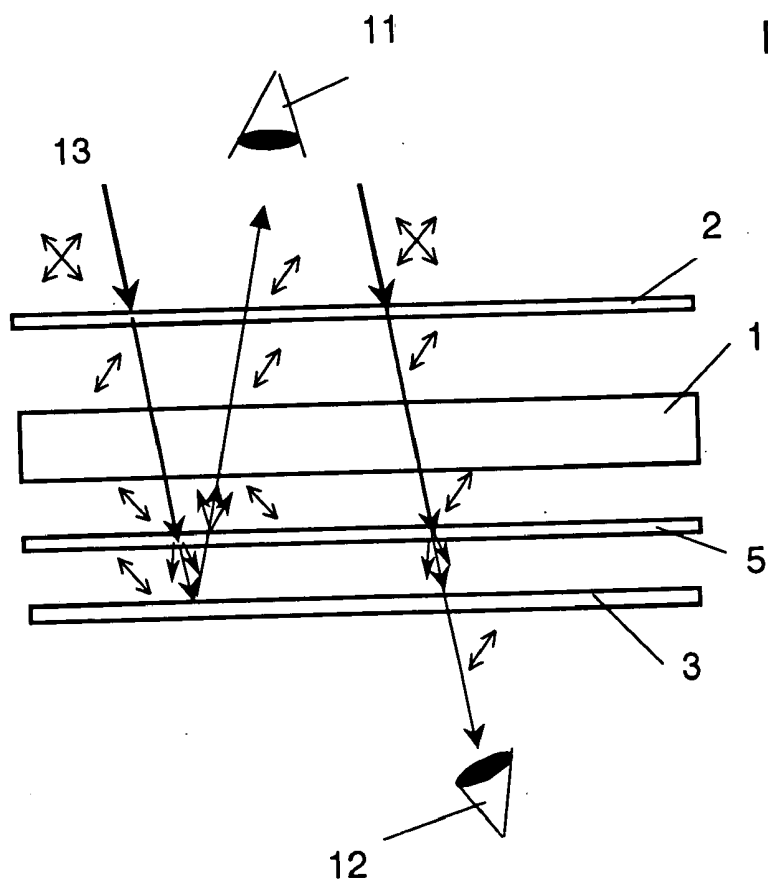

Fig. 4

Fig. 5

PRIOR ART

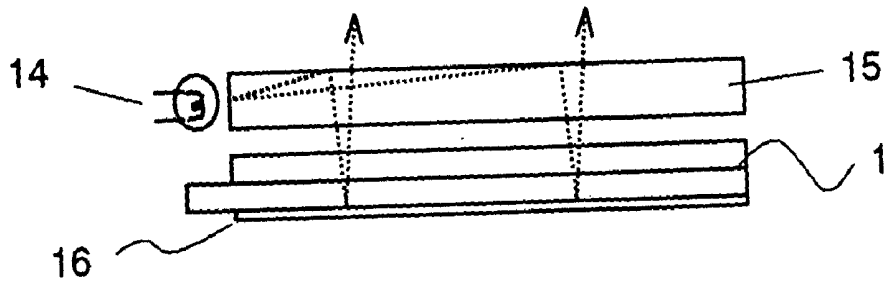

Fig. 6

PRIOR ART

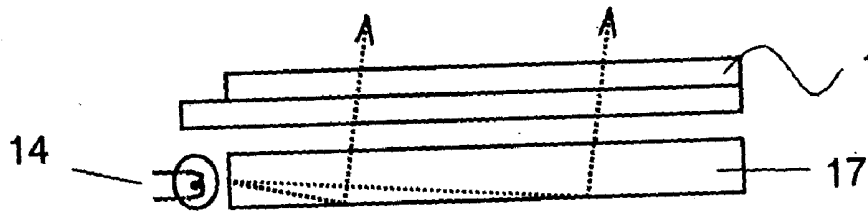

Fig. 7

PRIOR ART

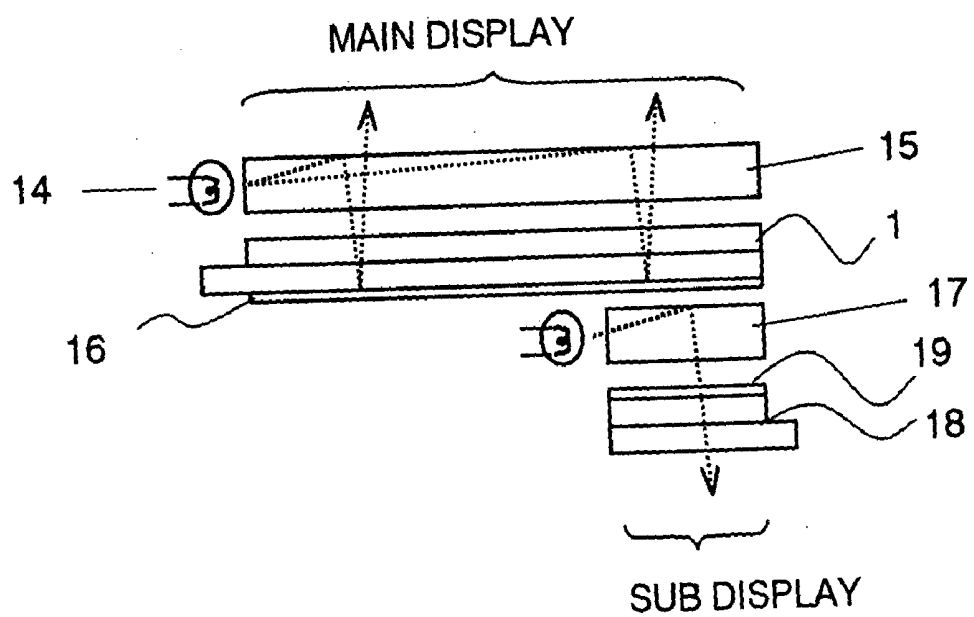

Fig. 8

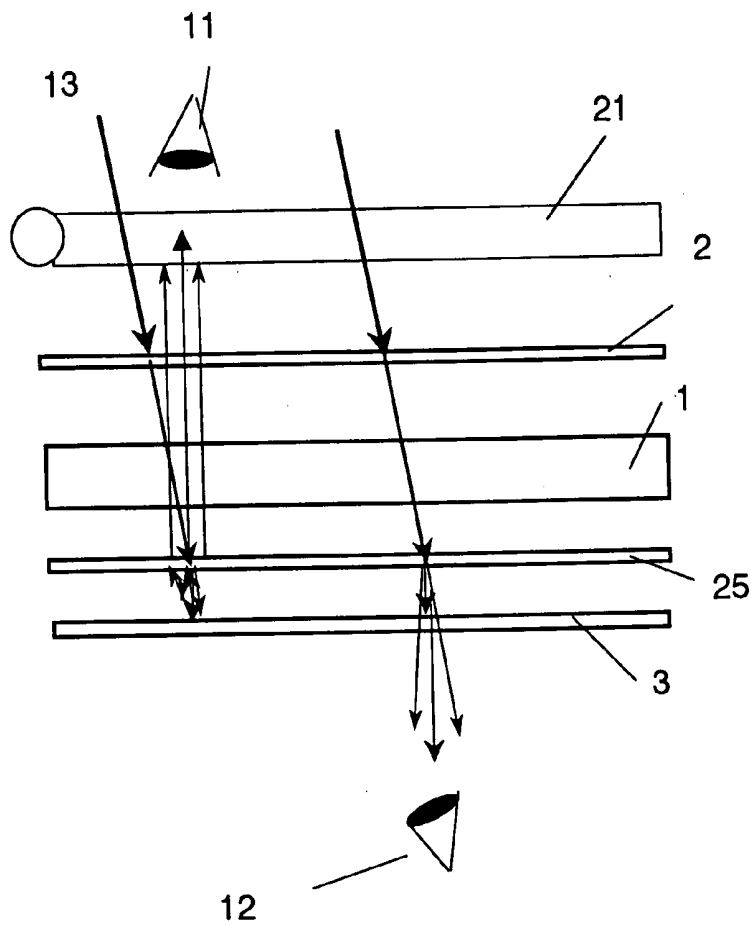
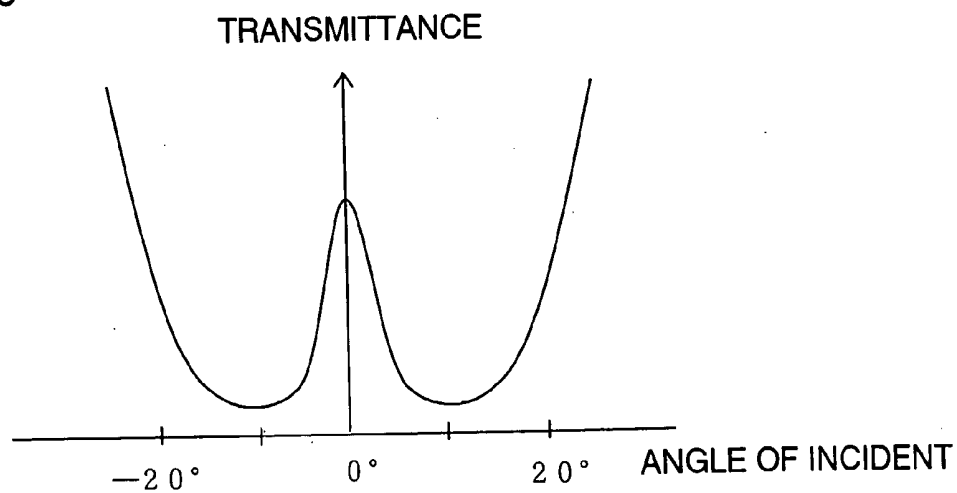

Fig. 9



LIQUID CRYSTAL DISPLAY DEVICE

BACKGROUND OF THE INVENTION

[0001] The present invention relates to a liquid crystal display device which is for use in time pieces, cellular phones, audio systems, and other electronic equipment and which allows a viewer to view display from the front and from the back both.

[0002] In recent years, liquid crystal devices characterized by their thinness and light-weightedness have been widely used in portable equipment and the like. In particular, cellular phones which are required to be small in size and weight almost always employ as their display devices such liquid crystal display devices. However, liquid crystal display devices are of light-receiving type and cannot provide enough visibility in dark places, which is one of requirements in cellular phones. This problem is often solved by installing an illumination device on the front or back of the liquid crystal display device. In general, the former illumination device is called a frontlight and the latter is called a backlight. A schematic sectional view of a front light type display device is shown in FIG. 5. A front light shown in the drawing has a light source 14 and an optical waveguide 15. Light from the light source 14 is guided downward (toward a liquid crystal display panel 1) by the optical waveguide 15 and is reflected by a reflector 16, which is provided on the back of the liquid crystal panel 1. In this way, information displayed on the liquid crystal panel 1 is made visible to a viewer. Light from the outside (external light) also enters the liquid crystal panel through the optical waveguide 15 and makes display on the liquid crystal panel 1 visible in a similar manner. On the other hand, a back light type display device is outlined in FIG. 6. A backlight in the drawing has a light source 14 and an optical waveguide 17, and is placed below a liquid crystal panel 1. Light from the light source 14 of the backlight is reflected upward via the optical waveguide 17 to illuminate the liquid crystal panel 1. Display is thus made visible to a viewer.

[0003] As described, the optical waveguide 15 of the front light is characterized by being structured to transmit light reflected by the reflector 16, whereas the optical waveguide 17 of the back light is merely capable of diffuse reflection of light and not transmission of light.

[0004] Latest cellular phones have a folding structure and this has prompted employment of a sub display device in addition to a main display device in order to enable a cellular phone user to see his/her cellular phone display information such as time and reception of a call even when the phone is folded. The sub display device makes it possible for a viewer to view from the back side of the main display device. To give an example, FIG. 7 shows a structure which has a combination of a frontlight and a liquid crystal panel 1 as a main display and a combination of a backlight and a liquid crystal panel 18 as a sub display. A semi-transmissive plate 19 is provided between an optical waveguide 17 and the liquid crystal panel 18 of the backlight if necessary.

[0005] Furthermore, a structure of a single liquid crystal panel, which can be viewed both from the front side and from the back side,, is known in a published application "JP-A No. 2000-132189". In this application, a first reflector is put on a part area of the front side of the liquid crystal panel. So, this area is only observed from the back side.

[0006] The conventional structure shown in FIG. 7 needs another display device for sub display in addition to a main display device. With the structure where the main display device and the sub display device overlap each other, the total thickness of the liquid crystal display device is large and the cellular phone or other device that has this liquid crystal display device is accordingly thick. Another problem of this structure relates to cost because a driver circuit and an illumination device for the sub display device are necessary aside from those for the main display device.

[0007] As described, the conventional structure cannot provide a thin and inexpensive liquid crystal display device that is capable of main display and sub display.

SUMMARY OF THE INVENTION

[0008] The present invention has been made in view of the above, and an object of the present invention is therefore to provide at low cost a liquid crystal display device which is thin and capable of displaying on both the front side and the back side.

[0009] A liquid crystal display device of the present invention is structured such that display on a single liquid crystal panel can be viewed in both ways, from the front and from the back. That is, the structure of the liquid crystal display device of the present invention has a liquid crystal panel in which a liquid crystal layer is interposed between opposing substrates, a polarizer provided on one side of the liquid crystal panel, and a reflection-polarizing plate provided on the other side of the liquid crystal panel to reflect a polarization component polarized in a specific direction while other polarization components are transmitted. The reflection axis of the reflection-polarizing plate is set in the same direction as a polarization direction of light that exits the liquid crystal panel after its polarization direction is changed in the liquid crystal layer, or a polarization direction of light that exits the liquid crystal panel without being changed in polarization direction in the liquid crystal layer.

[0010] The liquid crystal display device of the present invention also has a driver circuit for supplying the liquid crystal panel with a signal to be applied to the display panel after the signal is subjected to conversion processing in accordance with from which side of the polarizer side and the reflection-polarizing plate side the liquid crystal panel is to be viewed. This makes displayed text information visible from either side.

BRIEF DESCRIPTION OF THE DRAWINGS

[0011] FIGS. 1A and 1B are sectional views each schematically showing a structure of a liquid crystal display device according to the present invention;

[0012] FIG. 2 is a sectional view schematically showing a structure of a liquid crystal display device with a light unit according to the present invention;

[0013] FIG. 3 is a schematic sectional view showing a liquid crystal display device of Embodiment 2 according to the present invention;

[0014] FIG. 4 is a schematic sectional view showing a liquid crystal display device of Embodiment 3 according to the present invention;

[0015] FIG. 5 is a sectional view schematically showing a structure of a conventional liquid crystal display device that has a front light;

[0016] FIG. 6 is a sectional view schematically showing a structure of a conventional liquid crystal display device that has a back light;

[0017] FIG. 7 is a sectional view schematically showing a structure of a conventional liquid crystal display device capable of main display and sub display;

[0018] FIG. 8 is a schematic sectional view showing a liquid crystal display device of Embodiment 4 according to the present invention; and

[0019] FIG. 9 is a graph showing a characteristic of a directive diffusion layer used in the present invention.

DETAILED DESCRIPTION OF THE PREFERRED EMBODIMENTS

[0020] A liquid crystal display device of the present invention is structured such that a polarizer and a reflection-polarizing plate sandwich a liquid crystal panel in which a liquid crystal layer is interposed between opposing substrates. The liquid crystal layer has a portion where the polarization direction of incident light is changed before the light exits and a portion where incident light exits without changing its polarization direction. These portions are given different brightness to make display on the liquid crystal panel recognizable as an image. The reflection-polarizing plate has a function of reflecting a polarization component polarized in a specific direction and transmitting the rest. The reflection axis of the reflection-polarizing plate is set in the same direction as the polarization direction of light chosen out of components of light that enters the liquid crystal panel through the polarizer: a component (light) that exits the liquid crystal panel after its polarization direction is changed in the liquid crystal layer, or a component (light) that exits the liquid crystal panel without being changed in polarization direction in the liquid crystal layer.

[0021] This structure makes it possible to view display both from the polarizer side (a first view point) and from the reflection-polarizing plate side (a second view point) only with light that enters the liquid crystal panel from the polarizer side. In short, double-sided display of a single liquid crystal panel is made possible. In particular, when the first viewpoint is at a position of specular reflection with respect to the angle of incident of incident light, the brightest display can be viewed from the first viewpoint. In addition, the brightest display can be viewed from the second viewpoint when the second viewpoint is on a straight line that is extended from the angle of incident of incident light.

[0022] Light is prevented from entering a dark region (a portion where light from the reflection-polarizing plate toward the second view point side does not exit) of the liquid crystal panel from the second viewpoint side, thereby improving the visibility from the second view point side. For instance, the visibility from the second viewpoint side is improved by placing a second polarizer, whose absorption axis is in the same direction as the reflection axis of the reflection-polarizing plate, outside the reflection-polarizing plate, and thus eliminating light that is reflected toward the second viewpoint side in a dark region of the reflection-polarizing plate.

[0023] A diffusion layer is provided between the liquid crystal panel and the reflection-polarizing plate. With this structure, light scattered by the diffusion layer reaches each viewpoint, so that the viewing angle is widened at each viewpoint.

[0024] The diffusion layer between the liquid crystal panel and the reflection-polarizing plate may be replaced by a directive diffusion layer. The directive diffusion layer is set such that scattered light has directivity in a specific direction.

[0025] A driver circuit, which supplies the liquid crystal panel with a signal to be applied to the display panel after the signal is subjected to conversion processing in accordance with from which side of the first viewpoint side and the second viewpoint side the liquid crystal panel is to be viewed, makes it possible to freely switch between front side display and back side display. For example, mirror writing or upside-down letters can be converted into normal letters by such processing as changing the signal scanning direction. It is also possible to reverse negative display and positive display. Therefore, the display device can be set to show a viewer the same image (e.g., positive display of a normal letter) from both the front and the back.

[0026] Specific descriptions are given below on embodiments of the present invention with reference to the drawings.

[0027] Embodiment 1

[0028] A liquid crystal display device of this embodiment is described referring to FIGS. 1A and 1B.

[0029] As shown in the drawings, a liquid crystal panel 1 is interposed between a polarizer 2 and a reflection-polarizing plate 3. The liquid crystal panel 1 is structured such that a liquid crystal layer is sandwiched between transparent substrates such as glass substrates and plastic substrates. Display electrodes provided on the transparent substrates apply a voltage to the liquid crystal layer, thereby controlling alignment of liquid crystal molecules to display an image or text. Here, the polarizer has a function of absorbing a specific linear polarization component and transmitting other polarization components. The reflection-polarizing plate has a function of reflecting a specific linear polarization component and transmitting other polarization components. A viewpoint of a viewer on the side of the polarizer 2 is called a first viewpoint 11, whereas a viewpoint of a viewer on the side of the reflection-polarizing plate 3 is called a second viewpoint 12.

[0030] The operation principle of the thus structured liquid crystal display device is described taking as an example a case where light enters from the side of the polarizer 2. Of incident light 13 that enters from the side of the polarizer 2, a linear polarization component in the absorption axis direction of the polarizer 2 is absorbed as the incident light 13 passes through the polarizer 2, whereas the rest of the incident light 13 enters the display panel 1 (transmitted component). The polarization direction of the light that has reached the liquid crystal panel 1 is changed, in an off region (a region to which no voltage is applied) of the liquid crystal layer, in accordance with the twist angle of liquid crystal molecules. This light then exits the liquid crystal panel 1. On the other hand, light that travels in an on region (a region to which a voltage is applied) of the liquid crystal layer

maintains the polarization direction of the incident light and exits the liquid crystal panel 1 without a change. Of this exit light, a polarization component that matches the reflection axis direction of the reflection-polarizing plate 3 is reflected by the reflection-polarizing plate 3, whereas other components pass through the reflection-polarizing plate 3. If the direction of the polarization axis of light that has passed through the off region of the liquid crystal panel 1 matches the direction of the reflection axis of the reflection-polarizing plate 3, the light that has passed through the off region of the liquid crystal panel 1 is reflected by the reflection-polarizing plate 3 and therefore reaches the first view point 11 but not the second view point 12 as shown in FIG. 1A. On the other hand, light that has passed through the on region of the liquid crystal panel 1 is transmitted through the reflection-polarizing plate 3 and reaches the second view point 12 as shown in FIG. 1B. Accordingly, when viewed from the first viewpoint 11, the off region is displayed bright and the on region is displayed dark, whereas the off region is displayed dark and the on region is displayed bright when viewed from the second viewpoint 12. By thus setting the polarization axis of light that has passed through the off region of the liquid crystal panel 1 parallel to the reflection axis of the reflection-polarizing plate 3, the liquid crystal display device displays positive display of total reflection mode when viewed from the first viewpoint and negative display of total transmission mode when viewed from the second view point. In this case, it is desirable to prevent light from entering the display device from the second viewpoint side.

[0031] If an image to be viewed from the first viewpoint is seen from the second viewpoint in the display device structured as above, the image is reversed in negative/positive and has mirror writing or upside-down letters, depending on in what direction the liquid crystal panel is viewed. Accordingly, in order to view the same image from both the first viewpoint and the second viewpoint, a driver circuit for driving the liquid crystal panel 1 has to have a function of subjecting, before a signal is supplied to the liquid crystal panel, the signal to processing that changes the scanning direction in accordance with from which of the first viewpoint and the second viewpoint the display panel is to be viewed.

[0032] As shown in FIG. 2, the liquid crystal display device may have a front light type light unit 6 above the polarizer 2, so that display is made visible without external light that enters from the first viewpoint side. Here, the front light type light unit 6 has a function of transmitting light upward and downward as well as irradiating the liquid crystal panel 1 with illumination light. That is, the light unit 6 has a transmission function for transmitting external light that enters from the side of the first viewpoint 11 and for guiding the light to the liquid crystal panel and a light emission function for emitting illumination light from a built-in light source toward the liquid crystal panel. The transmission function is utilized in an environment where external light of enough brightness is available. The light emission function is utilized in an environment where external light of enough brightness is unavailable.

[0033] Embodiment 2

[0034] A liquid crystal display device of this embodiment is described referring to FIG. 3. Similar to Embodiment 1,

the description takes as an example a case where light enters from the side of the polarizer 2. The points that have already been described in Embodiment 1 will not be repeated.

[0035] In this embodiment, the liquid crystal panel 1 is interposed between the polarizer 2 and a second polarizer 4, and the reflection-polarizing plate 3 is placed between the liquid crystal panel 1 and the second polarizer 4 as shown in the drawing. Here, the reflection axis of the reflection-polarizing plate 3 is set parallel to the polarization axis of light that has passed through the off region of the liquid crystal panel 1. Also, the reflection axis of the reflection-polarizing plate 3 is in the same direction as the absorption axis of the second polarizer 4.

[0036] When the display panel is viewed from the first viewpoint, the description in Embodiment 1 applies to this embodiment and therefore is omitted.

[0037] When the structure that does not have the second polarizer 4 (namely, the structure of Embodiment 1) is viewed from the second view point side, light that enters from the second view point side is undesirable because its light (component) in the reflection axis direction of the reflection-polarizing plate 3 is reflected by the reflection-polarizing plate toward the second view point side. In other words, reflected light from the off region of the liquid crystal panel 1 that is displayed dark from the second view point reaches the second view point, thus affecting the visibility of a dark portion from the second view point.

[0038] This embodiment has the second polarizer 4 whose absorption axis is in the same direction as the reflection axis of the reflection-polarizing plate 3, and therefore a light component that is to be reflected by the reflection polarizing plate 3 toward the second viewpoint side is absorbed by the second polarizer 4 beforehand. This makes it possible to eliminate light reflected toward the second view point side by the off region of the liquid crystal panel 1 that is displayed dark when viewed from the second view point. Obtained as a result is an effect of improving display visibility from the second viewpoint side even when there is light that enters from the second viewpoint side.

[0039] Similar to Embodiment 1, the liquid crystal display device of this embodiment may have a front light type light unit above the polarizer 2. As a result, display is made visible from either viewpoint even in a dark environment.

[0040] Embodiment 3

[0041] A liquid crystal display device of this embodiment is described referring to FIG. 4. Similar to the above embodiments, the description takes as an example a case where light enters from the side of the polarizer 2. The points that have already been described in the above embodiments will not be repeated.

[0042] In this embodiment, the liquid crystal panel 1 is interposed between the polarizer 2 and a reflection-polarizing plate 3, and a diffusion layer 5 is placed between the liquid crystal panel 1 and the reflection-polarizing plate 3 as shown in the drawing. Here, the reflection axis of the reflection-polarizing plate 3 is set parallel to the polarization axis of light that has passed through the off region of the liquid crystal panel 1. Also, the diffusion layer has a function of scattering light in a specific region when the light is transmitted through the diffusion layer.

[0043] With such diffusion layer, light scattered by the diffusion layer **5** is reflected by the reflection-polarizing plate and reaches the first viewpoint which may not be in the specular reflection direction of the angle of incident of the incident light **13**. Therefore, the viewing angle is widened for a viewer at the first viewpoint. The viewing angle is widened also for a viewer at the second view point because light scattered by the diffusion layer **5** travels through the reflection-polarizing plate **3** and reaches the second view point which may not be on a straight line that is extended from the angle of incident of the incident light **13**.

[0044] Accordingly, reflected components or transmitted components scattered in various directions by the diffusion layer and by the reflection-polarizing plate widen the viewing angle of a viewer irrespective of a change in angle of incident of the incident light **13** or a change in view point of a viewer (namely, a change in relative position between the angle of incident of incident light and a viewer).

[0045] Similar to Embodiment 1, the liquid crystal display device of this embodiment may have a front light type light unit above the polarizer **2**. As a result, display is made visible from either viewpoint even in a dark environment.

[0046] Embodiment 4

[0047] A liquid crystal display device of this embodiment is described referring to **FIG. 8**. In this embodiment, an example is given where a directive diffusion layer is provided instead of a diffusion layer. Similar to the above embodiments, the description takes as an example a case where light enters from the side of the polarizer **2**. The points that have already been described in the above embodiments will not be repeated.

[0048] In this embodiment, the liquid crystal panel **1** is interposed between the polarizer **2** and the reflection-polarizing plate **3**, and a directive diffusion layer **25** is placed between the liquid crystal panel **1** and the reflection-polarizing plate **3** as shown in the drawing. The liquid crystal panel is provided with a front light **21** for radiating illumination light as shown in the drawing. Here, the reflection axis of the reflection-polarizing plate **3** is set parallel to the polarization axis of light that has passed through the off region of the liquid crystal panel **1**. The directive diffusion layer **25** has a function of scattering light that enters at an angle within a specific angle range and directing the scattered light in a specific direction. According to characteristics of the directive diffusion layer **25**, incident light from the thickness direction (the normal line direction) is mostly transmitted, light having an angle of incident of 5 to 15 degrees is scattered and efficiently gathered in the thickness direction, namely, in front of a viewer, and light having an angle of incident of 20 degrees, which is the critical angle, or more is mostly transmitted. This makes it possible to view at the first viewpoint **11** the incident light **13** of various incident angles and the brightness is improved. **FIG. 9** shows the relation between the angle of incident and the transmittance of the directive diffusion layer. In **FIG. 9**, the angle of incident of light that enters the directive diffusion layer from the thickness direction (the normal line direction) is 0 degree.

[0049] Now, a case of viewing display from the first viewpoint **11** is considered. To obtain a better view of display with external light, the directive diffusion layer

should have an excellent reflection characteristic. It is therefore preferable to use a directive diffusion layer that is small in transmittance and large in scattering ability. On the other hand, when the front light is put into use, a better view of display is obtained by using a directive diffusion layer that is large in transmittance and small in scattering ability.

[0050] In the case where display is viewed from the second viewpoint **12**, on the other hand, the directive diffusion layer is required to have an excellent transmission characteristic. A directive diffusion layer that is large in transmittance and small in scattering ability is thus preferred. The use of a directive diffusion layer having such characteristics is also helpful in avoiding blurred display.

[0051] In each of the drawings illustrating the above embodiments, optical elements such as the polarizer and the reflection-polarizing plate are separated from other structural components. However, the optical elements may be joined to the liquid crystal panel and other structural components by an adhesive.

[0052] According to a liquid crystal display device of the present invention, a single liquid crystal panel can be viewed both from the front side and from the back side to thereby allow the display device to be thinner. In addition, the viewing angle can be widened on either side of the display device by placing a diffusion layer between the liquid crystal panel and the reflection-polarizing plate. Moreover, a second polarizer placed outside the reflection-polarizing plate improves the visibility of display viewed from the second viewpoint.

What is claimed is:

1. A liquid crystal display device, comprising:

a liquid crystal panel in which a liquid crystal layer is interposed between opposing substrates;

a polarizer provided on one side of the liquid crystal panel; and

a reflection-polarizing plate provided on the other side of the liquid crystal panel to reflect a polarization component polarized in a specific direction while other polarization components are transmitted,

wherein the reflection axis of the reflection-polarizing plate is set in the same direction as one of: a polarization direction of light that exits the liquid crystal panel after a polarization direction of the light is changed in the liquid crystal layer; and a polarization direction of light that exits the liquid crystal panel without being changed in polarization direction in the liquid crystal layer.

2. A liquid crystal display device according to claim 1, further comprising a light-shielding object provided outside the reflection-polarizing plate, wherein the light-shielding object blocks light that enters into the liquid crystal panel from the reflection-polarizing plate.

3. A liquid crystal display device according to claim 1, further comprising a second polarizer having an absorption axis that is in the same direction as the reflection axis of the reflection-polarizing plate, outside the reflection-polarizing plate.

4. A liquid crystal display device according to claim 1, further comprising a diffusion layer between the liquid crystal panel and the reflection-polarizing plate.

5. A liquid crystal display device according to claim 1, wherein a directive diffusion layer for scattering light that enters at an angle within a specific angle range while transmitting light that enters at an angle outside the specific angle range is interposed between the liquid crystal panel and the reflection-polarizing plate.

6. A liquid crystal display device according to claim 5, wherein light scattered by the directive diffusion layer has directivity in a specific direction.

7. A liquid crystal display device according to claim 1, wherein a front light type light unit for irradiating the liquid

crystal panel with light from the polarizer side is provided outside the polarizer.

8. A liquid crystal display device according to claim 1, further comprising a driver circuit for supplying the liquid crystal panel with a signal to be applied to the display panel after the signal is subjected to conversion processing in accordance with from which side of the polarizer side and the reflection-polarizing plate side the liquid crystal panel is to be viewed.

* * * * *

专利名称(译)	液晶显示装置		
公开(公告)号	US20040109112A1	公开(公告)日	2004-06-10
申请号	US10/634450	申请日	2003-08-05
[标]申请(专利权)人(译)	山内尚史 KURIHARA MAKOTO		
申请(专利权)人(译)	山内尚史 KURIHARA MAKOTO		
当前申请(专利权)人(译)	山内尚史 KURIHARA MAKOTO		
[标]发明人	YAMAUCHI NAOFUMI KURIHARA MAKOTO		
发明人	YAMAUCHI, NAOFUMI KURIHARA, MAKOTO		
IPC分类号	G02F1/133 G02F1/1335 G02F1/13357		
CPC分类号	G02F1/133504 G02F2001/133616 G02F2001/133342 G02F1/133536		
优先权	2003203903 2003-07-30 JP 2002233372 2002-08-09 JP		
其他公开文献	US7142270		
外部链接	Espacenet USPTO		

摘要(译)

为了以低成本实现一种薄的液晶显示装置，其中可以从前面和后面以两种方式观察单个液晶面板上的显示。液晶显示装置包括：液晶面板，其中液晶层插入在相对的基板之间；以及偏振器和反射偏振板，设置成将液晶面板插入其间。反射偏振片的反射轴设定在与液晶面板的偏振方向变化后离开液晶面板的光的偏振方向相同的方向，或者离开液晶的光的偏振方向。在液晶层中没有改变偏振方向的面板。由于这种布置，可以提供一种薄的并且能够在前侧和后侧都显示的液晶显示装置。

