



(19) **United States**

(12) **Patent Application Publication** (10) **Pub. No.: US 2004/0085281 A1**

**Chung et al.** (43) **Pub. Date: May 6, 2004**

(54) **CHIP-ON-GLASS TYPE LIQUID CRYSTAL DISPLAY**

(52) **U.S. Cl. .... 345/98**

(76) Inventors: **Kyung Hoon Chung**, Kyoungki-do (KR); **Nak Hyun Sung**, Seoul (KR)

(57) **ABSTRACT**

Correspondence Address:  
**LADAS & PARRY**  
**224 SOUTH MICHIGAN AVENUE, SUITE 1200**  
**CHICAGO, IL 60604 (US)**

Disclosed is a chip-on-glass type liquid crystal display (LCD). The LCD is directed to provide a construction in a way that, while each wiring for supplying driver circuits with a driving voltage is directly formed on an LCD panel through application of COG (Chip-On-Glass) technology for producing TFT-LCD, even though the wirings are connected in series between the driver circuits, the driving voltage capable of normally operating the driver circuits is supplied to all driver circuits. To this end, in consideration of a voltage drop at the panel wiring, by increasing and outputting a driving voltage, the driving voltage inputted into an n<sup>th</sup> driver circuit is made to be equal to the driving voltage inputted into an (n+1)<sup>th</sup> driver circuit. To accomplish this object, a driving voltage generating section is provided to each driver IC, and comprises a charge pumping circuit for increasing the leading gate driving voltage to a predetermined level, and a buffer circuit for stabilizing an output voltage of the charge pumping circuit.

(21) Appl. No.: **10/620,716**

(22) Filed: **Jul. 16, 2003**

(30) **Foreign Application Priority Data**

Nov. 4, 2002 (KR) ..... 2002-67817

**Publication Classification**

(51) **Int. Cl.<sup>7</sup> ..... G09G 3/36**

200

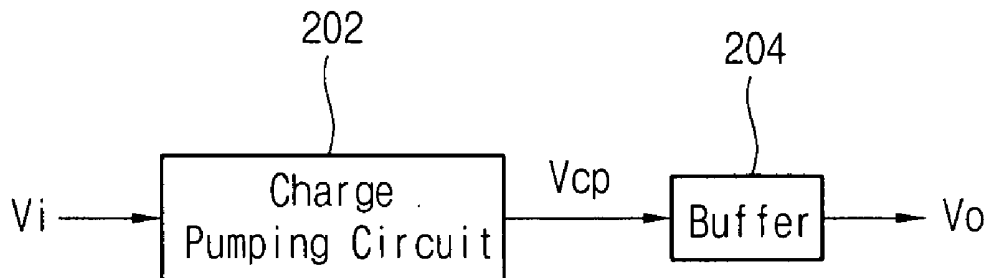

# FIG. 1

(PRIOR ART)

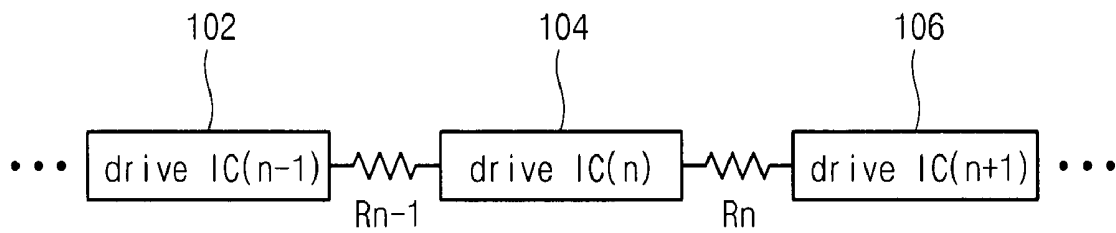

# FIG. 2

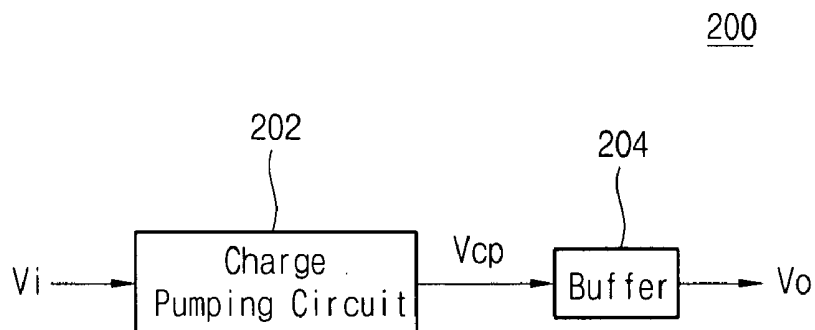

FIG.3

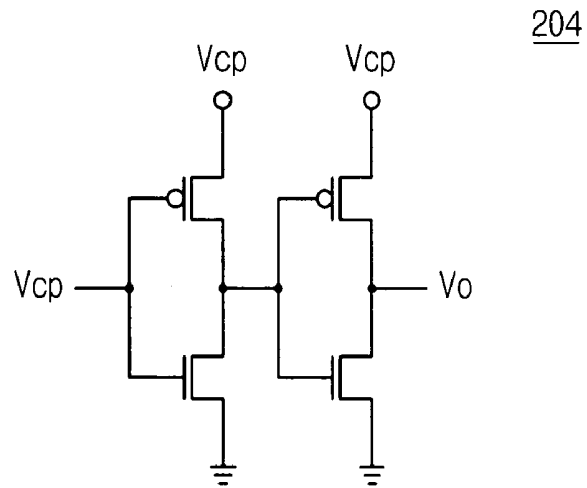
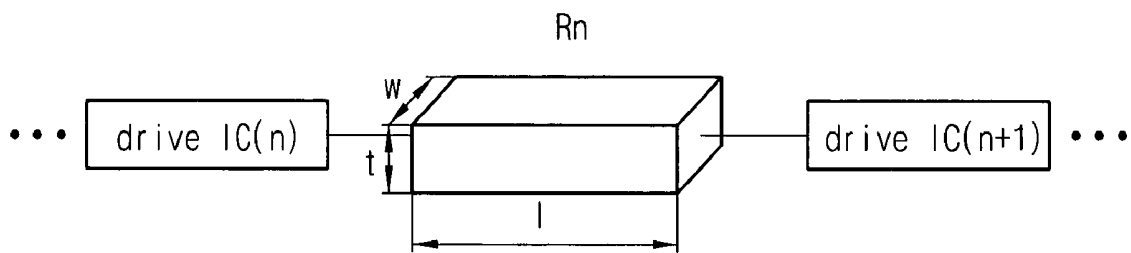

FIG.4



## CHIP-ON-GLASS TYPE LIQUID CRYSTAL DISPLAY

### BACKGROUND OF THE INVENTION

[0001] 1. Field of the Invention

[0002] The present invention relates to a liquid crystal display (LCD), and more particularly to a chip-on-glass type liquid crystal display in which each wiring for driver circuits is directly formed on an LCD panel.

[0003] 2. Description of the Prior Art

[0004] An active matrix type LCD includes a plurality of thin film transistors (hereinafter, referred to as "TFTs"), which are located around intersectional points between a plurality of scan lines and a plurality of signal lines, and by which a plurality of liquid crystal pixels are driven. The scan lines are each connected to an external gate driver IC, which provides scan signals. The signal lines are each connected to an external source driver IC, which provides image signals. When the image signals inputted from the source driver IC are applied to liquid crystals through the TFTs turned on by the scan signals, a designated image is displayed.

[0005] There are various methods of connecting the scan lines to the gate driver IC and of connecting the signal lines to the source driver IC, for example, TAB (Tape Automated Bonding) using a printed circuit board, and chip-on-glass (hereinafter, referred to as "COG"). In the COG method, both a gate driver IC and a source driver IC are directly attached onto an LCD panel by soldering or a metallic paste, and similarly each wiring for the gate driver IC and the source driver IC is directly performed on the LCD panel. In general, the wiring formed directly on the panel by application of this COG technology is referred to as "panel wiring". Herein, the gate driver IC and the source driver IC are together generically referred to as a "driver circuit". Further, a voltage applied to each driver circuit in order to drive the driver circuit is called a "driving voltage".

[0006] FIG. 1 shows how a driving voltage is applied to respective driver circuits 102, 104 and 106 through each panel wiring between the driver circuits. Each panel wiring can be modeled into resistors  $R_{n-1}$  and  $R_n$ . As shown in FIG. 1, when the panel wirings  $R_{n-1}$  and  $R_n$  for supplying the driving voltage to the driver circuits 102, 104 and 106 are connected in series between the driver circuits 102, 104 and 106, a voltage drop is generated by internal resistance components of the driver circuits 102, 104 and 106 and by resistance components of the panel wirings  $R_{n-1}$  and  $R_n$ . Owing to this voltage drop, a relationship as the following Formula 1 is established:

$$Vo(n-1) > Vi(n) > Vo(n) > Vi(n+1) \quad \text{Formula 1}$$

[0007] where  $Vi(n)$  is the input driving voltage applied to the driver circuit 104 in reality, and  $Vo(n)$  is the output driving voltage outputted from the driver circuit 104 in order to drive next circuit.

[0008] For this reason, when several driver circuits are connected with each other, an input driving voltage applied actually to a driver circuit after a certain step drops less than the minimum voltage (referred to as an "operation voltage") necessary to operate the driver circuit, so that the circuit may not perform normal operation.

### SUMMARY OF THE INVENTION

[0009] Accordingly, the present invention has been made to solve the above-mentioned problems occurring in the prior art, and an object of the present invention is to provide a chip-on-glass type liquid crystal display (LCD) having a type of construction in that while each wiring for supplying driver circuits with a driving voltage is directly formed on an LCD panel through application of COG (Chip-On-Glass) technology for producing TFT-LCD, even though the wirings are connected in series between the driver circuits, the driving voltage capable of normally operating the driver circuits is supplied to all driver circuits.

[0010] To this end, the present invention is designed so that, in consideration of a voltage drop at the panel wiring, by increasing and outputting a driving voltage, the driving voltage inputted into an  $n$ th driver circuit is made to be equal to the driving voltage inputted into an  $(n+1)$ th driver circuit.

[0011] In order to accomplish this object, there is provided a chip-on-glass type liquid crystal display (LCD) comprising: an LCD panel having a plurality of pixels; a plurality of source driving sections connected in series by first panel wiring formed on the LCD panel, supplied with a driving voltage through the first panel wiring, generating contrast voltages corresponding to data to be displayed on the LCD panel, and providing the generated contrast voltages to the LCD panel; and a plurality of gate driving sections connected in series by second panel wiring formed on the LCD panel, supplied with a driving voltage through the second panel wiring, and scanning the plurality of pixels of the LCD panel sequentially row by row, wherein each of the plurality of source driving sections increases and outputs an inputted source driving voltage to make a leading source driving voltage equal to a trailing source driving voltage, while each of the plurality of gate driving sections increases and outputs an inputted gate driving voltage to make a leading gate driving voltage equal to a trailing gate driving voltage.

[0012] Preferably, each of the gate driving sections comprises a charge pumping circuit for increasing the leading gate driving voltage to a predetermined level, and a buffer circuit for stabilizing an output voltage of the charge pumping circuit.

[0013] It is also preferred that each of the source driving sections comprises a charge pumping circuit for increasing the leading source driving voltage to a predetermined level, and a buffer circuit for stabilizing an output voltage of the charge pumping circuit.

[0014] It is preferred that the buffer circuit connects two CMOS (Complementary Metal Oxide Semiconductors) inverters in series, and makes use of the output voltage of the charge pumping circuit as an input voltage and a driving voltage of the buffer circuit. Further, by increasing and outputting the driving voltage higher than the original driving voltage, and then by adjusting resistance values of the panel wirings in the process, an  $n$ th driving voltage is made to be equal to an  $(n+1)$ th driving voltage.

[0015] According to this construction of the present invention, there is no possibility that due to a voltage drop, trailing driver circuits are not operated. Further, there is an advantage in that there is no restriction on the number of serial connected driver circuits.

## BRIEF DESCRIPTION OF THE DRAWINGS

[0016] The above and other objects, features and advantages of the present invention will be more apparent from the following detailed description taken in conjunction with the accompanying drawings, in which:

[0017] **FIG. 1** is a view for explaining a connection between driver circuits in a liquid crystal display;

[0018] **FIG. 2** is a block diagram of a driving voltage generating section according to one embodiment of the present invention;

[0019] **FIG. 3** shows a circuit of one example of the buffer circuit shown in **FIG. 2**; and

[0020] **FIG. 4** is a view for explaining a resistance value of a panel wiring according to the present invention.

## DETAILED DESCRIPTION OF THE PREFERRED EMBODIMENTS

[0021] Hereinafter, a preferred embodiment of the present invention will be described in detail with reference to the accompanying drawings. For a consistent description, the same reference numerals are used to designate the same or similar elements or signals.

[0022] **FIG. 2** is a block diagram of a driving voltage generating section according to one embodiment of the present invention. As shown in **FIG. 2**, the driving voltage generating section **200** having a charge pumping circuit **202** and a buffer circuit **204** is provided to each driver IC.

[0023] The charge pumping circuit **202** increases a driving voltage  $V_i$  applied from a leading driver IC to a predetermined level and then outputs the increased driving voltage as a voltage  $V_{cp}$ . The charge pumping circuit **202** has been already widely known in the art, and thus its specific construction will not be disclosed herein. The buffer circuit **204** generates a voltage  $V_o$  by stabilizing the voltage  $V_{cp}$  outputted from the charge pumping circuit **202**, and then outputs the voltage  $V_o$  to a next circuit.

[0024] **FIG. 3** shows a circuit of one example of the buffer circuit shown in **FIG. 2**. As shown in **FIG. 3**, the buffer circuit **204** can be constructed by two CMOS (Complementary Metal Oxide Semiconductor) inverters, which are connected with each other in series. In order to output the voltage  $V_{cp}$  increased by the charge pumping circuit **202**, the voltage  $V_{cp}$  functions as a driving voltage and an input voltage of the buffer circuit **204**. The buffer circuit **204** is constructed as the CMOS circuit to output the voltage  $V_{cp}$  without a loss.

[0025] **FIG. 4** is a view for explaining a resistance value of panel wiring according to the present invention. In **FIG. 4**, a resistance  $R_n$  is represented as in Formula 2 as follows:

$$R_n = \rho * l / (w * t) \quad \text{Formula 2}$$

[0026] where  $\rho$  is the specific resistance,  $l$  is the length,  $w$  is the width, and  $t$  is the thickness.

[0027] As mentioned above, in consideration of a voltage drop at the panel wiring, by previously increasing and outputting the voltage, and additionally by adjusting  $l$ ,  $w$  and  $t$  of the panel wiring through a process technique, the voltage dropped by the panel wiring is adjusted, and thereby consequently  $V_i(n)$  is allowed to be equal to  $V_i(n+1)$ .

[0028] That is, according to the present invention, by providing the foregoing driving voltage generating section **200** (**FIG. 2**) inside the  $n^{\text{th}}$  driver IC, after outputting the voltage increased higher than the inputted driving voltage, by a proper adjustment of a resistance value of the panel wiring in the process, a gate and source driving voltage applied to  $n^{\text{th}}$  driver ICs, i.e., leading gate and source driver ICs is adapted to be equal to a gate and source driving voltage applied to  $(n+1)^{\text{th}}$  driver ICs, i.e., trailing gate and source driver ICs.

[0029] According to this construction of the present invention, there is no possibility that due to a voltage drop, trailing driver circuits are not operated. Further, there is an advantage in that there is no restriction on the number of serial connected driver circuits.

[0030] Although a preferred embodiment of the present invention has been described for illustrative purposes, those skilled in the art will appreciate that various modifications, additions and substitutions are possible, without departing from the scope and spirit of the invention as disclosed in the accompanying claims.

What is claimed is:

1. A chip-on-glass type liquid crystal display (LCD), comprising:

an LCD panel having a plurality of pixels;

a plurality of source driving sections connected in series by first panel wiring formed on the LCD panel, supplied with a driving voltage through the first panel wiring, generating contrast voltages corresponding to data to be displayed on the LCD panel, and providing the generated contrast voltages to the LCD panel; and

a plurality of gate driving sections connected in series by second panel wiring formed on the LCD panel, supplied with a driving voltage through the second panel wiring, and scanning the plurality of pixels of the LCD panel sequentially row by row,

wherein each of the plurality of source driving sections increases and outputs an inputted source driving voltage to make a leading source driving voltage equal to a trailing source driving voltage, while each of the plurality of gate driving sections increases and outputs an inputted gate driving voltage to make a leading gate driving voltage equal to a trailing gate driving voltage.

2. A chip-on-glass type LCD as claimed in claim 1, wherein each of the gate driving sections comprises a charge pumping circuit for increasing the leading gate driving voltage to a predetermined level, and a buffer circuit for stabilizing an output voltage of the charge pumping circuit.

3. A chip-on-glass type LCD as claimed in claim 1, wherein each of the source driving sections comprises a charge pumping circuit for increasing the leading source driving voltage to a predetermined level, and a buffer circuit for stabilizing an output voltage of the charge pumping circuit.

4. A chip-on-glass type LCD as claimed in claim 2 or 3, wherein the buffer circuit includes two CMOS (Complementary Metal Oxide Semiconductors) inverters connected with each other in series; and wherein the output voltage of

the charge pumping circuit is used as an input voltage and a driving voltage of the buffer circuit.

5. A chip-on-glass type LCD as claimed in claim 2, wherein the first panel wiring has a resistance value adjusted according to an output voltage of the buffer circuit and process parameters of a length, a width and a thickness of the first panel wiring.

6. A chip-on-glass type LCD as claimed in claim 3, wherein the second panel wiring has a resistance value adjusted according to an output voltage of the buffer circuit and process parameters of a length, a width and a thickness of the second panel wiring.

\* \* \* \* \*

专利名称(译)	玻璃上芯片型液晶显示器		
公开(公告)号	<a href="#">US20040085281A1</a>	公开(公告)日	2004-05-06
申请号	US10/620716	申请日	2003-07-16
[标]申请(专利权)人(译)	CHUNG KYUNG HOON SUNG NAK HYUN		
申请(专利权)人(译)	CHUNG KYUNG HOON SUNG NAK HYUN		
当前申请(专利权)人(译)	BOE-HYDIS TECHNOLOGY CO. , LTD.		
[标]发明人	CHUNG KYUNG HOON SUNG NAK HYUN		
发明人	CHUNG, KYUNG HOON SUNG, NAK HYUN		
IPC分类号	G02F1/1345 G02F1/133 G09F9/00 G09G3/20 G09G3/36		
CPC分类号	G09G3/3611 G09G2320/0223 G09G3/3648		
优先权	1020020067817 2002-11-04 KR		
其他公开文献	US7102611		
外部链接	<a href="#">Espacenet</a> <a href="#">USPTO</a>		

摘要(译)

公开了一种玻璃上芯片型液晶显示器 ( LCD )。 LCD旨在提供一种结构，即通过应用COG ( 玻璃上芯片 ) 技术直接在LCD面板上形成用于为驱动电路提供驱动电压的每个布线，以生产TFT-LCD，甚至尽管布线在驱动器电路之间串联连接，但是能够正常操作驱动器电路的驱动电压被提供给所有驱动器电路。为此，考虑到面板布线的电压降，通过增加和输出驱动电压，使输入到第n个驱动电路的驱动电压等于输入到 ( n + 1 ) 的驱动电压。 1 ) <驱动电路。为了实现该目的，向每个驱动器IC提供驱动电压产生部分，并且包括用于将引导栅极驱动电压增加到预定电平的电荷泵浦电路，以及用于稳定电荷泵浦电路的输出电压的缓冲电路。

