



US008194227B2

(12) **United States Patent**
Tanaka et al.

(10) **Patent No.:** **US 8,194,227 B2**
(45) **Date of Patent:** **Jun. 5, 2012**

(54) **METHOD OF FABRICATING A
MULTI-DOMAIN VERTICAL ALIGNMENT
(MVA) LIQUID CRYSTAL DISPLAY**

(75) Inventors: **Sakae Tanaka**, Mito (JP); **Samejima
Toshiyuki**, Kodaira (JP)

(73) Assignee: **Mikuni Electoron Co. Ltd.** (JP)

(*) Notice: Subject to any disclaimer, the term of this
patent is extended or adjusted under 35
U.S.C. 154(b) by 216 days.

(21) Appl. No.: **12/558,086**

(22) Filed: **Sep. 11, 2009**

(65) **Prior Publication Data**

US 2010/0066931 A1 Mar. 18, 2010

Related U.S. Application Data

(62) Division of application No. 11/743,749, filed on May
3, 2007.

(30) **Foreign Application Priority Data**

Jun. 15, 2006 (JP) 2006-202563

(51) **Int. Cl.**

G02F 1/136 (2006.01)

G02F 1/1337 (2006.01)

G02F 1/13 (2006.01)

(52) **U.S. Cl.** **349/187**; 349/43; 349/130

(58) **Field of Classification Search** 349/129-131,
349/187, 43; 438/30

See application file for complete search history.

(56) **References Cited**

U.S. PATENT DOCUMENTS

6,177,970 B1 1/2001 Kim
6,462,800 B1 10/2002 Kim et al.
6,784,955 B2 8/2004 Kwok et al.

7,495,733 B2* 2/2009 Lee et al. 349/141
2003/0095219 A1 5/2003 Lee
2004/0048405 A1* 3/2004 Hirota 438/29
2004/0114059 A1 6/2004 Lee et al.
2004/0227891 A1* 11/2004 Hirota 349/141

(Continued)

FOREIGN PATENT DOCUMENTS

JP 07-230097 8/1995

(Continued)

OTHER PUBLICATIONS

Office Action (Mail Date Apr. 2, 2009) for U.S. Appl. No.
11/743,749, filed May 3, 2007; Confirmation No. 7467.

(Continued)

Primary Examiner — Mark Robinson

Assistant Examiner — Michael Inadomi

(74) *Attorney, Agent, or Firm* — Schmeiser, Olsen & Watts,
LLP

(57) **ABSTRACT**

The present invention discloses a super large wide-angle
high-speed response liquid crystal display apparatus manu-
factured by using a photolithographic procedure for three
times. The invention adopts a halftone exposure technology
to form a gate electrode, a common electrode, a pixel elec-
trode and a contact pad, and then uses the halftone exposure
technology to form a silicon (Si) island and a contact hole,
and a general exposure technology to form a source electrode,
a drain electrode and an orientation control electrode. A pas-
sivation layer uses a masking deposition method. A film is
formed by using a P-CVD method, or a protective area is
formed at a local area by using an ink coating method or spray
method, and a TFT array substrate used for the super large
wide-angle high-speed response liquid crystal display appa-
ratus manufactured by using a photolithographic procedure
for three times can be produced.

1 Claim, 42 Drawing Sheets

MVA Mode Using a Photolithographic Procedure for Three Times (B)

(1) Form a gate electrode, a pixel electrode and a contact pad in the pixel

electrode (wherein the photolithographic procedure uses a halftone exposure
method for the first time).

(2) Form a separate thin film semiconductor layer component, and a contact hole
(wherein the photolithographic procedure uses a halftone exposure method for
the second time).

(3) Form a source electrode, a drain electrode, an orientation control electrode
and a common electrode (wherein the photolithographic procedure uses a
general exposure method).

After an ohmic contact layer of a channel portion of the thin film transistor is dry
etched, a partial film of a passivation layer is formed by a silicon nitride film by
using a mask deposition method (wherein the film is formed at a terminal portion
other than those of a gate electrode, a source electrode and a common electrode).

U.S. PATENT DOCUMENTS

2005/0024548 A1 2/2005 Choi et al.
2005/0036091 A1 2/2005 Song
2006/0055861 A1 3/2006 Hirota
2007/0291209 A1 12/2007 Tanaka et al.
2008/0231781 A1 9/2008 Ge et al.
2010/0066930 A1 3/2010 Tanaka et al.
2010/0066962 A1 3/2010 Tanaka et al.
2010/0309420 A1 12/2010 Tanaka et al.

FOREIGN PATENT DOCUMENTS

JP 11-109393 4/1999
JP 2001-042347 2/2001

OTHER PUBLICATIONS

Office Action (Mail Date Dec. 29, 2009) for U.S. Appl. No. 11/743,749, filed May 3, 2007.
Office Action (Mail Date Dec. 7, 2010) for U.S. Appl. No. 11/743,749, filed May 3, 2007.
Office Action (Mail Date Aug. 19, 2011) for U.S. Appl. No. 11/743,749, filed May 3, 2007.
Office Action (Mail Date Oct. 25, 2010) for U.S. Appl. No. 12/558,050, filed Sep. 11, 2009.
Office Action (Mail Date Sep. 21, 2011) for U.S. Appl. No. 12/558,065, filed Sep. 11, 2009.

* cited by examiner

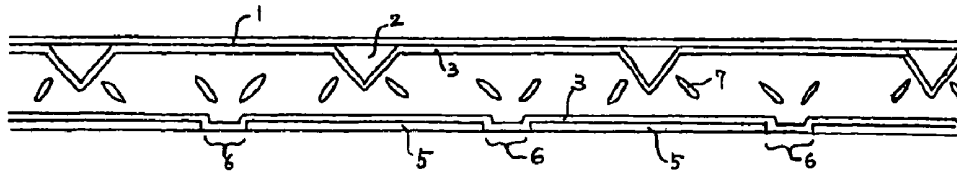

Fig. 1

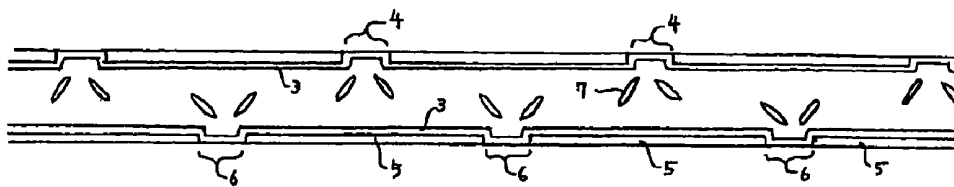

Fig. 2

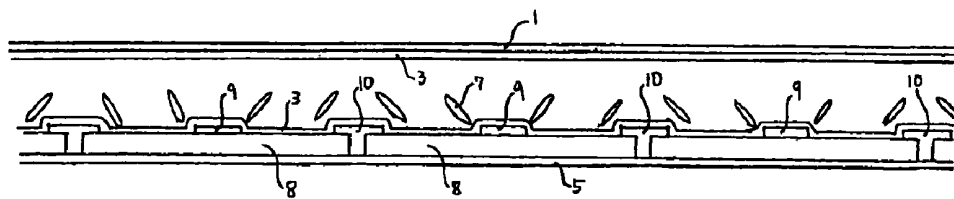

Fig. 3

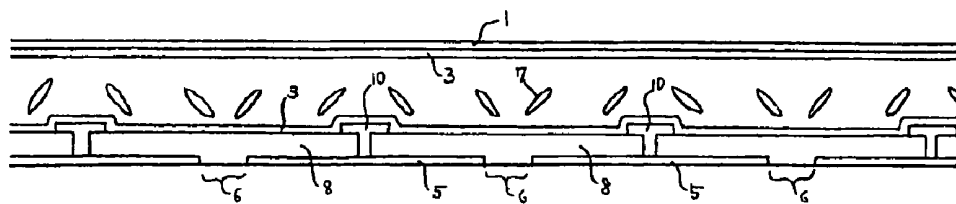

Fig. 4

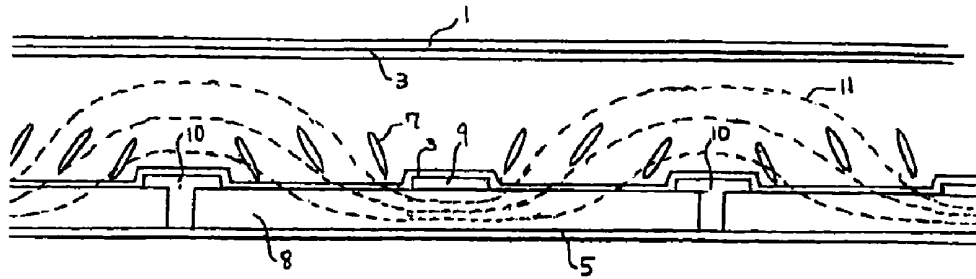

Fig. 5

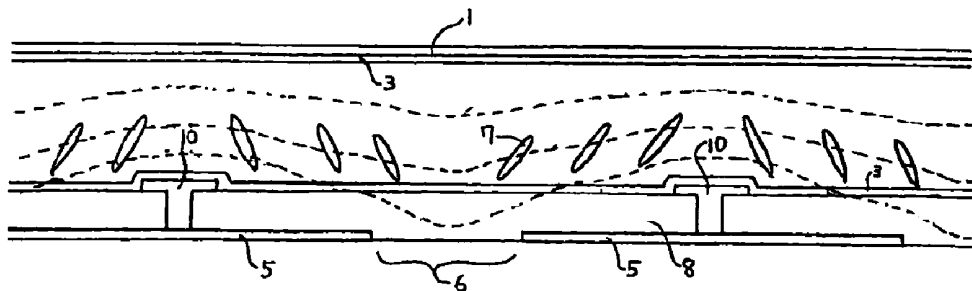

Fig. 6

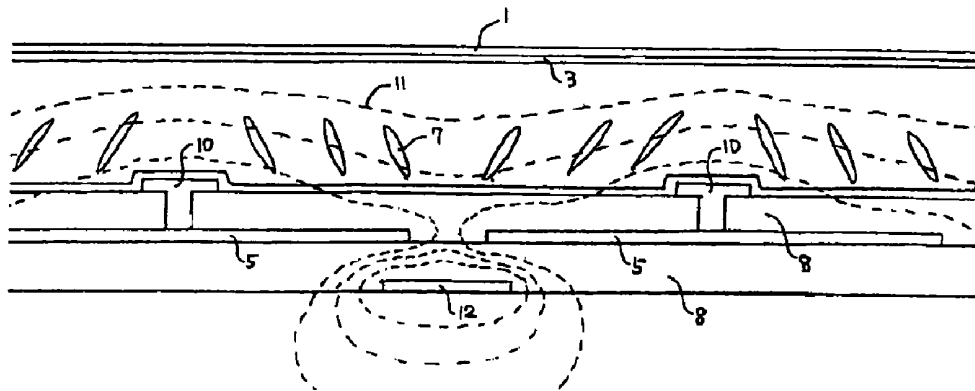

Fig. 7

Photolithographic procedure for 3 times (Half-tone exposure for 2 times)

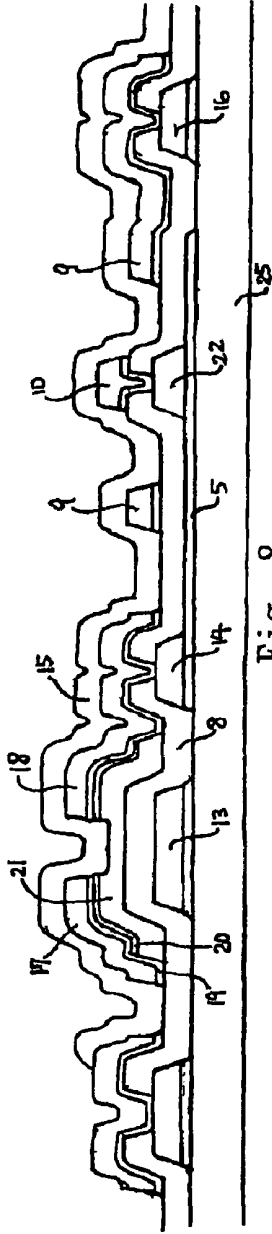

Fig. 8

Photolithographic procedure for 3 times (Half-tone exposure for 2 times)

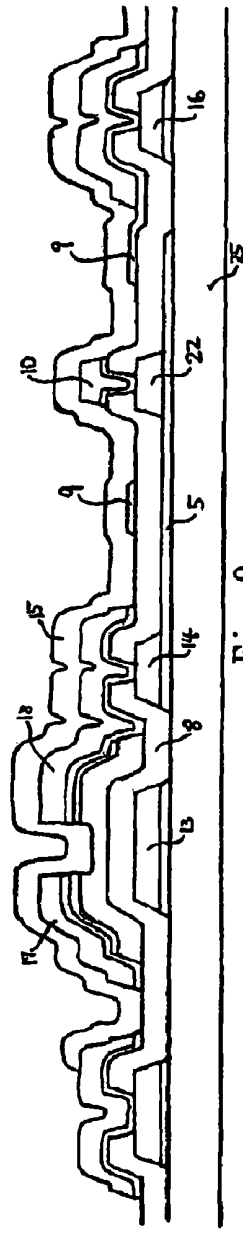

Fig. 9

Photolithographic procedure for 3 times (Half-tone exposure for 2 times)

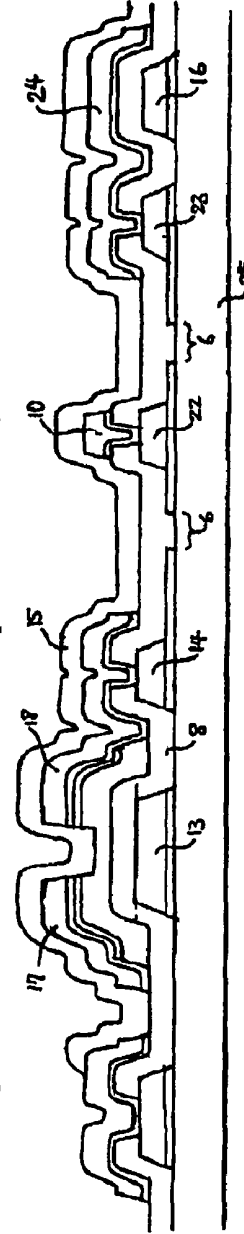

Fig. 10

Photolithographic procedure for 4 times (Halftone exposure for 2 times)

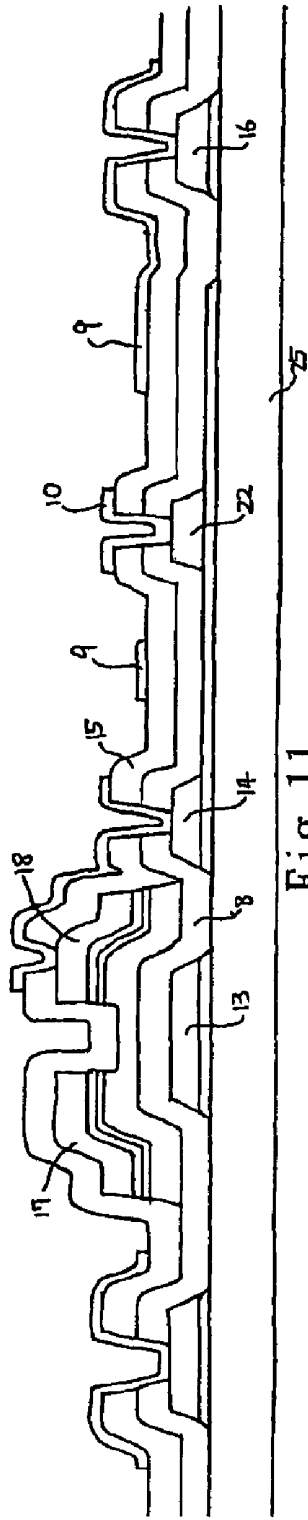

Fig. 11

Photolithographic procedure for 4 times (Halftone exposure for 2 times)

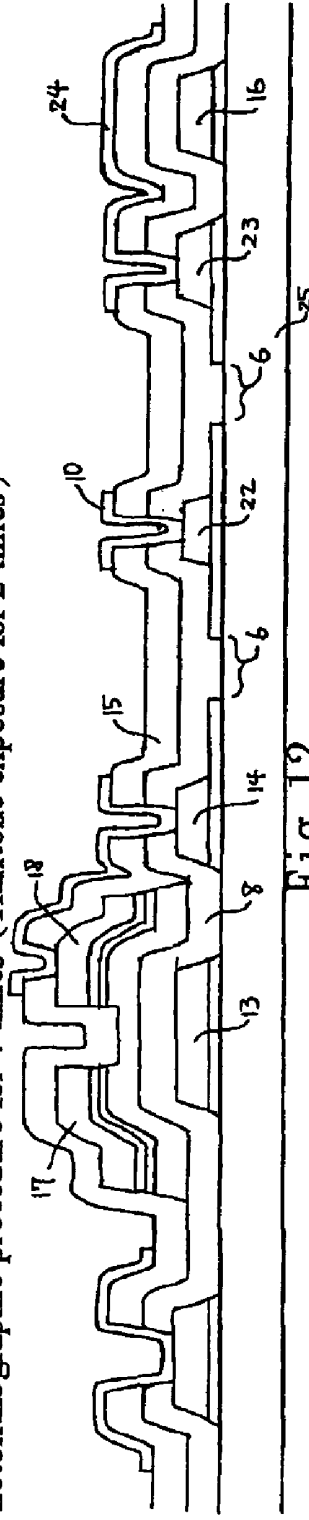

Fig. 12

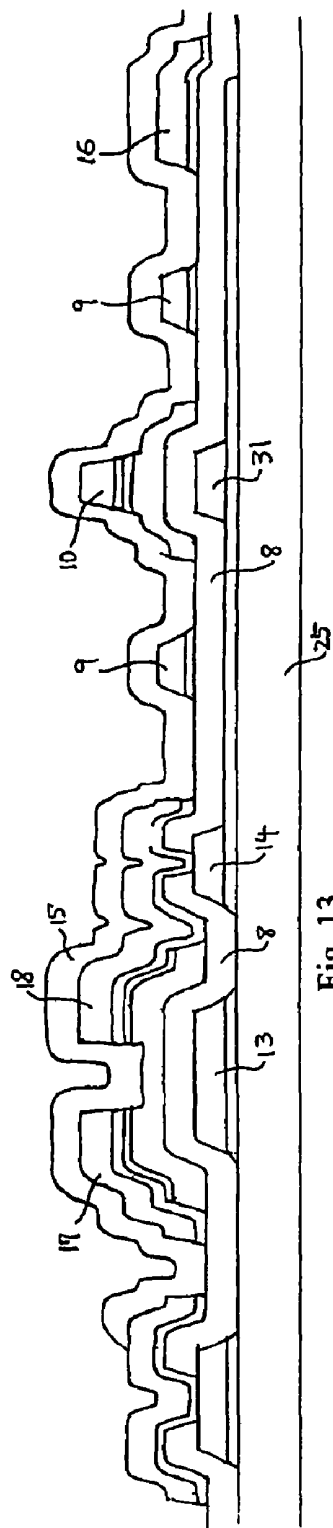

Fig. 13

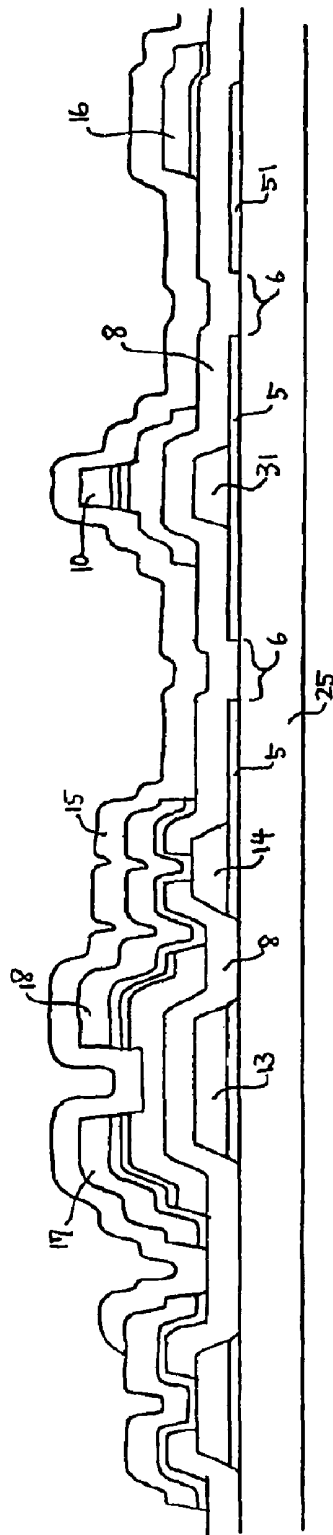

Fig. 14

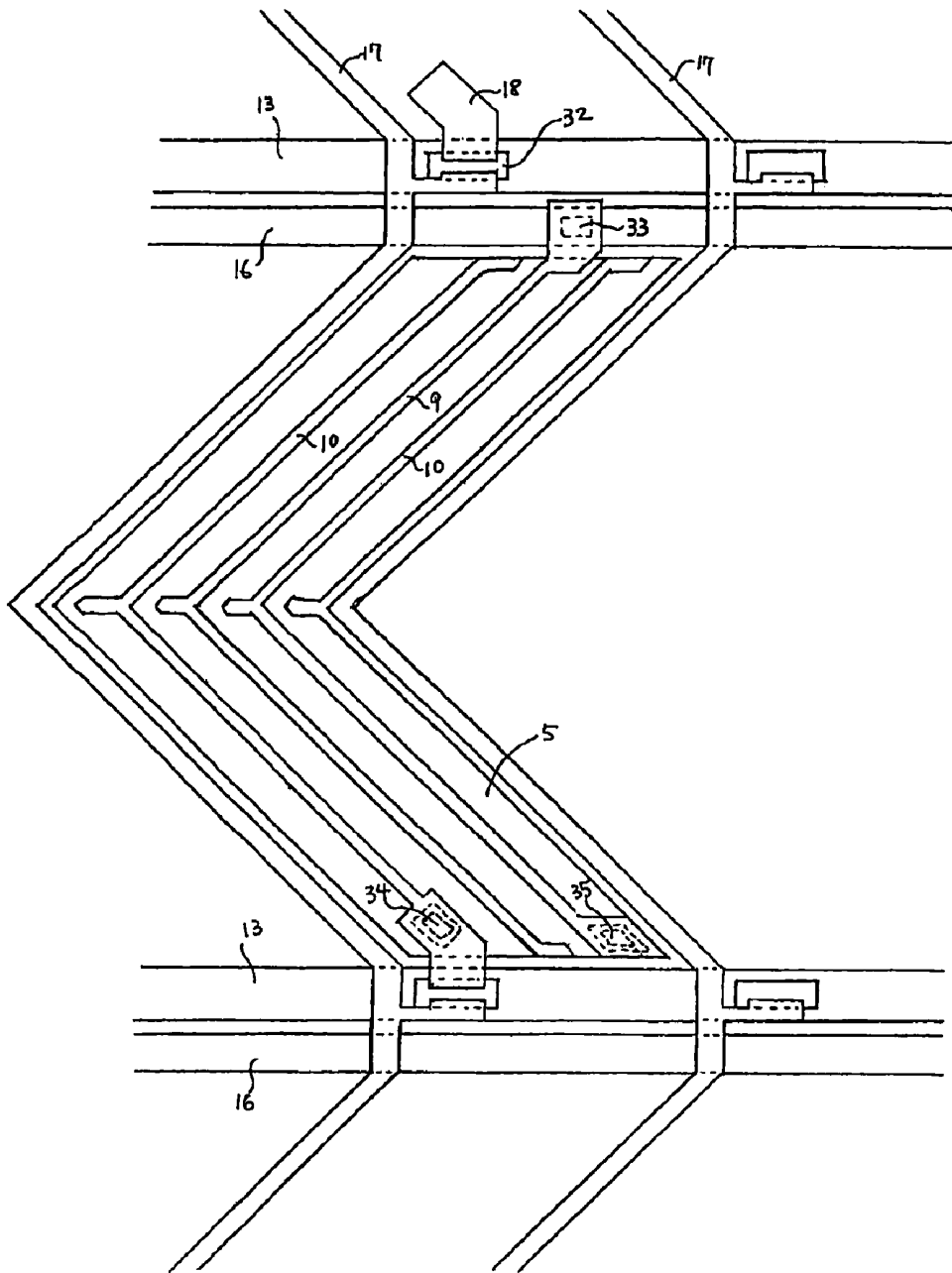

Fig. 15

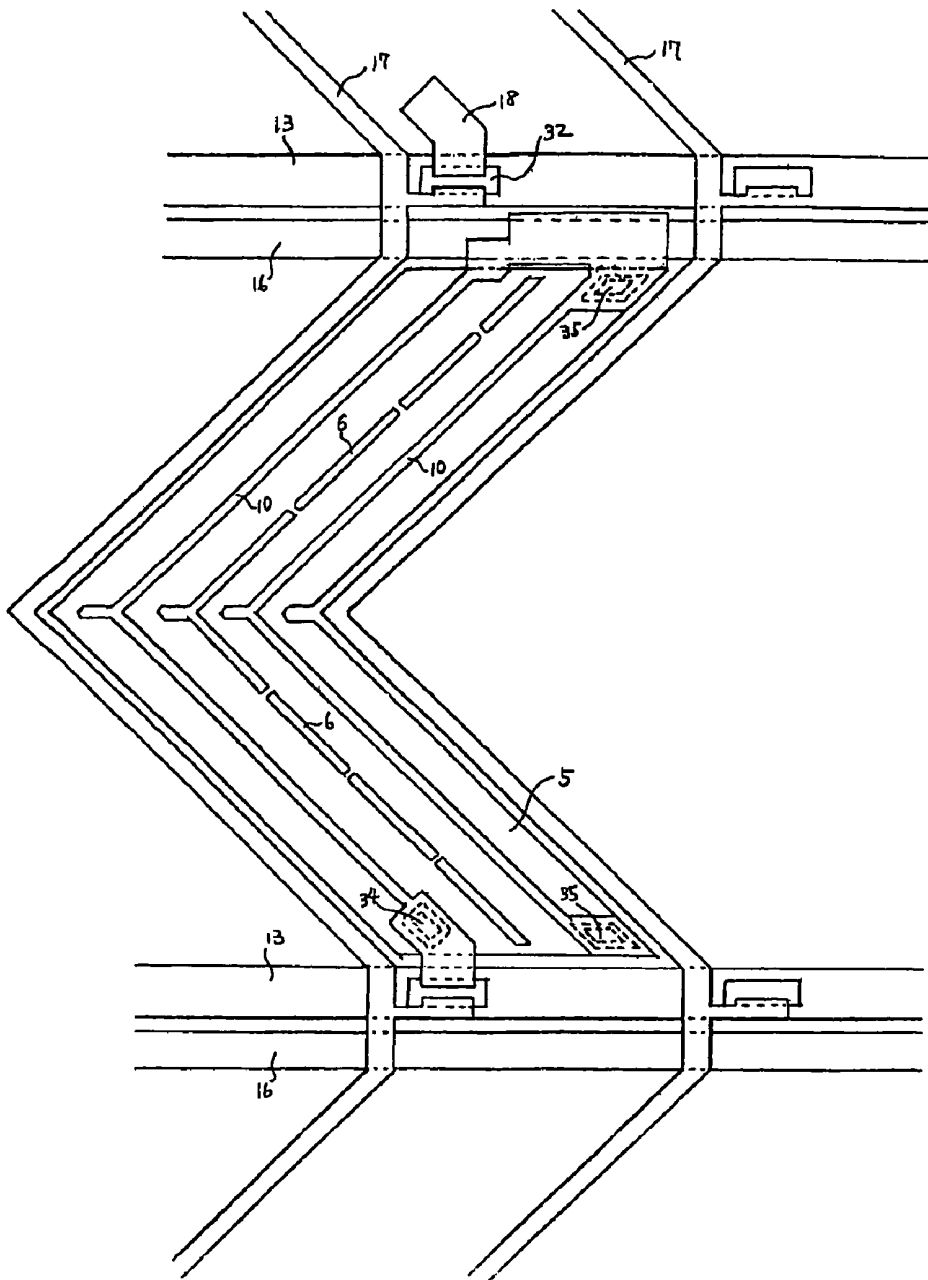

Fig. 16

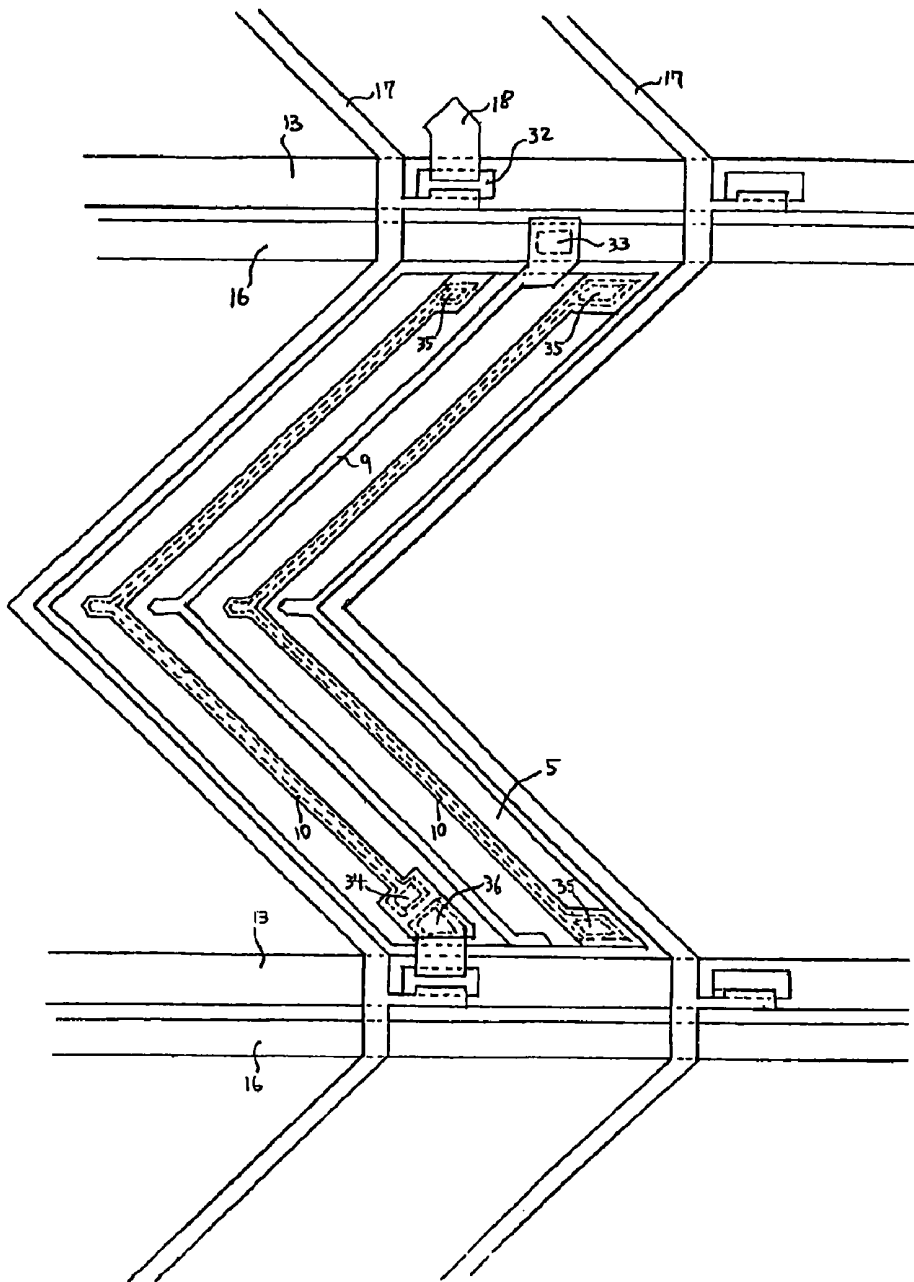

Fig. 17

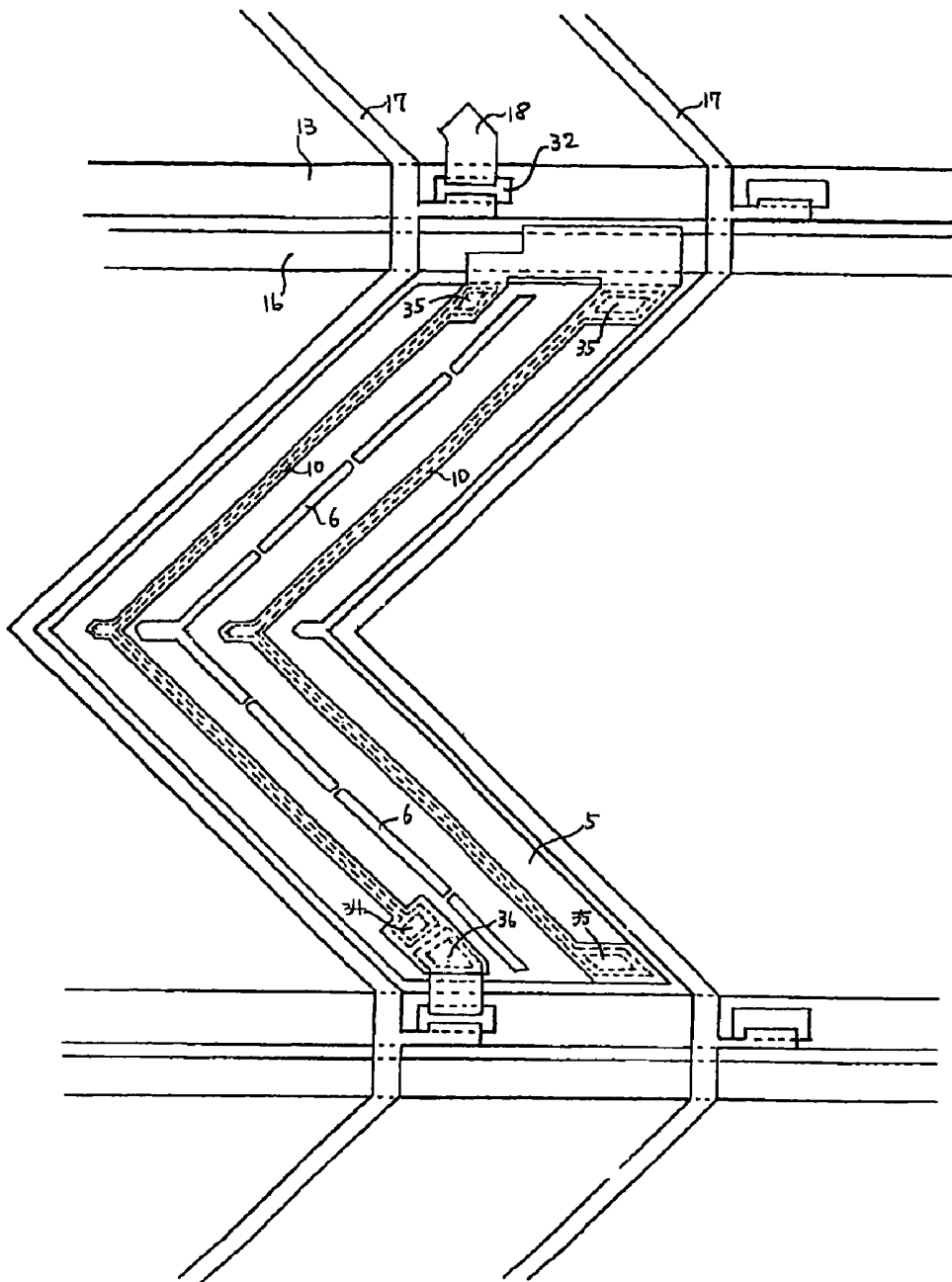

Fig. 18

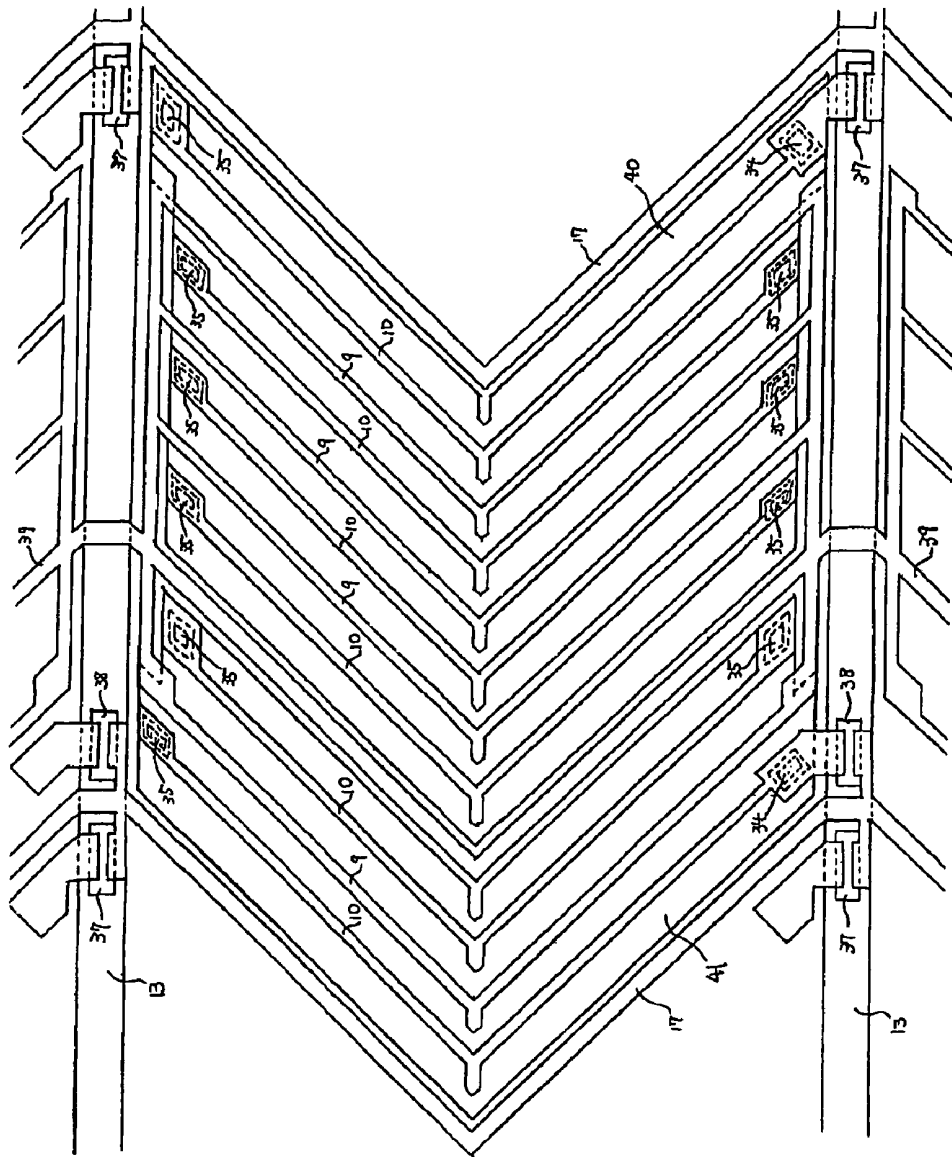

Fig. 19

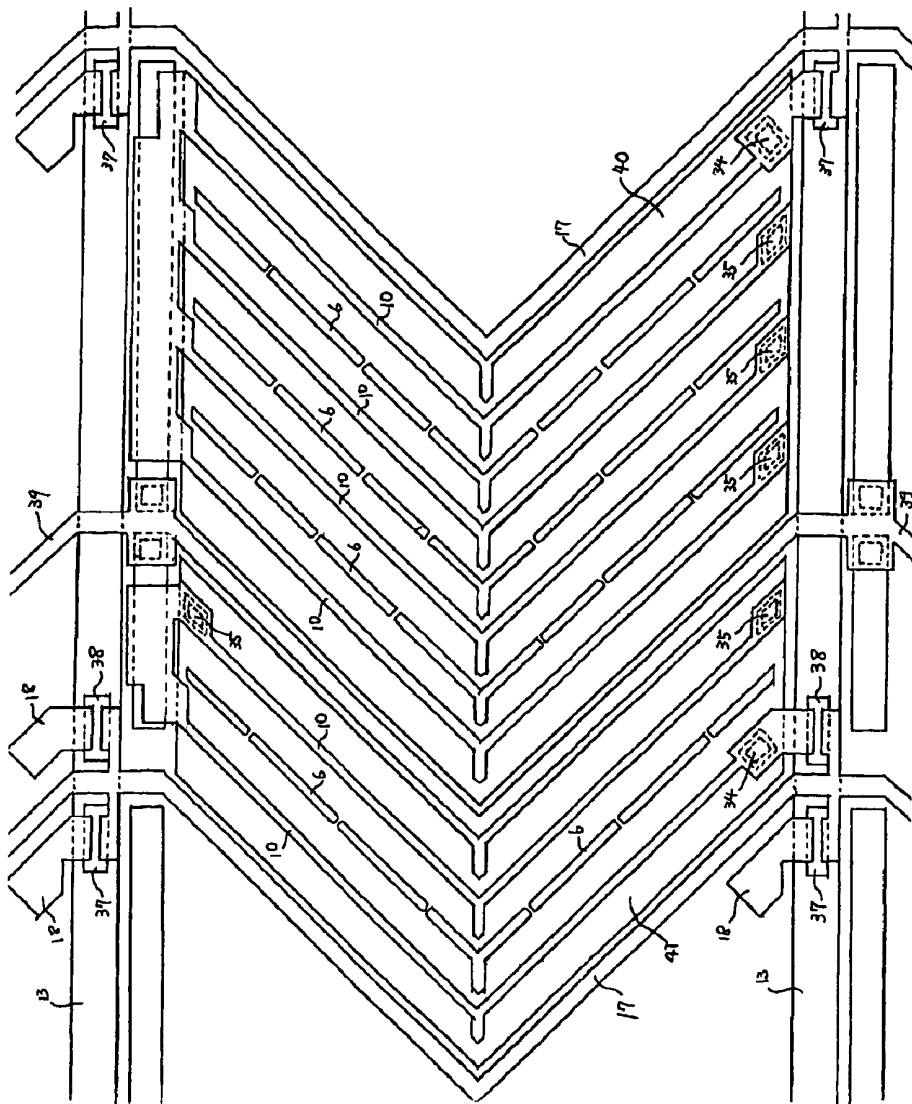

Fig. 20

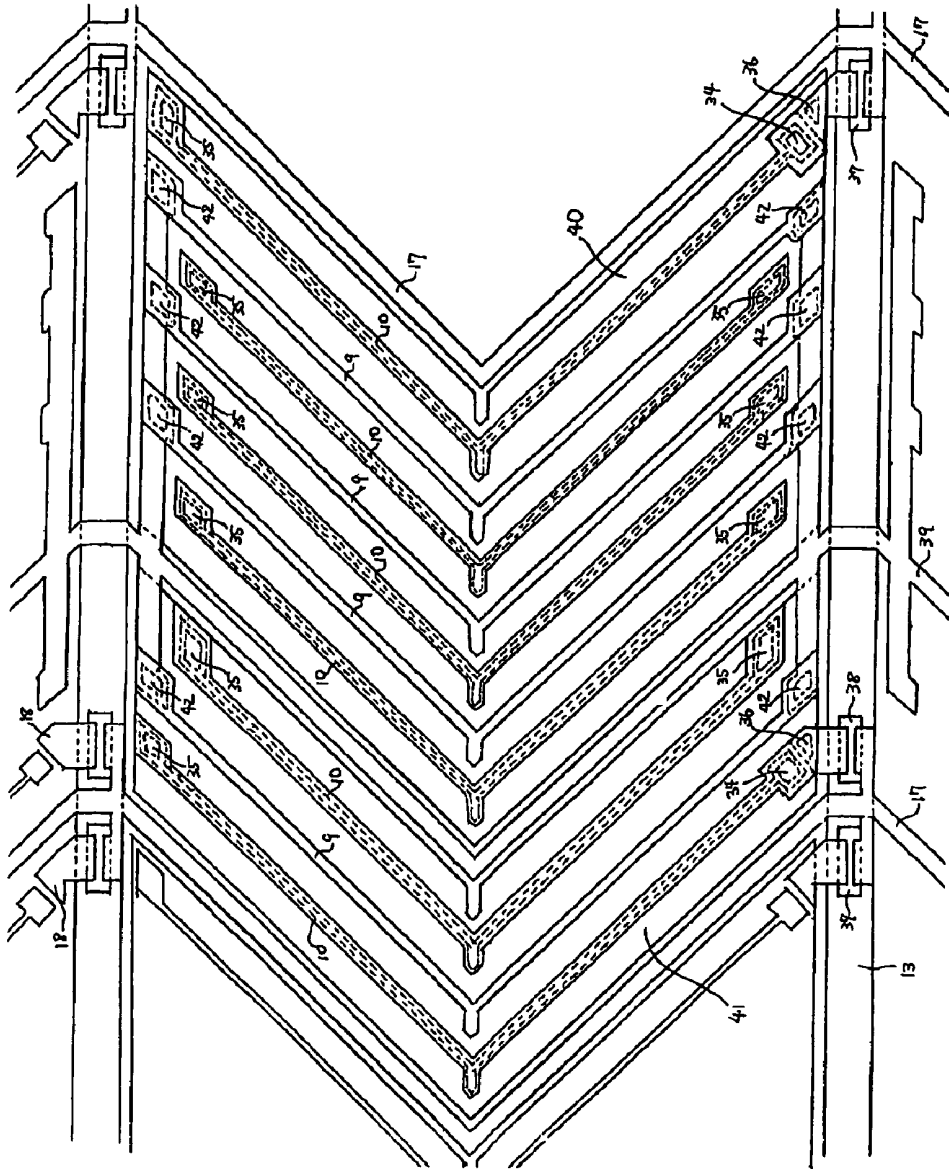

Fig. 21

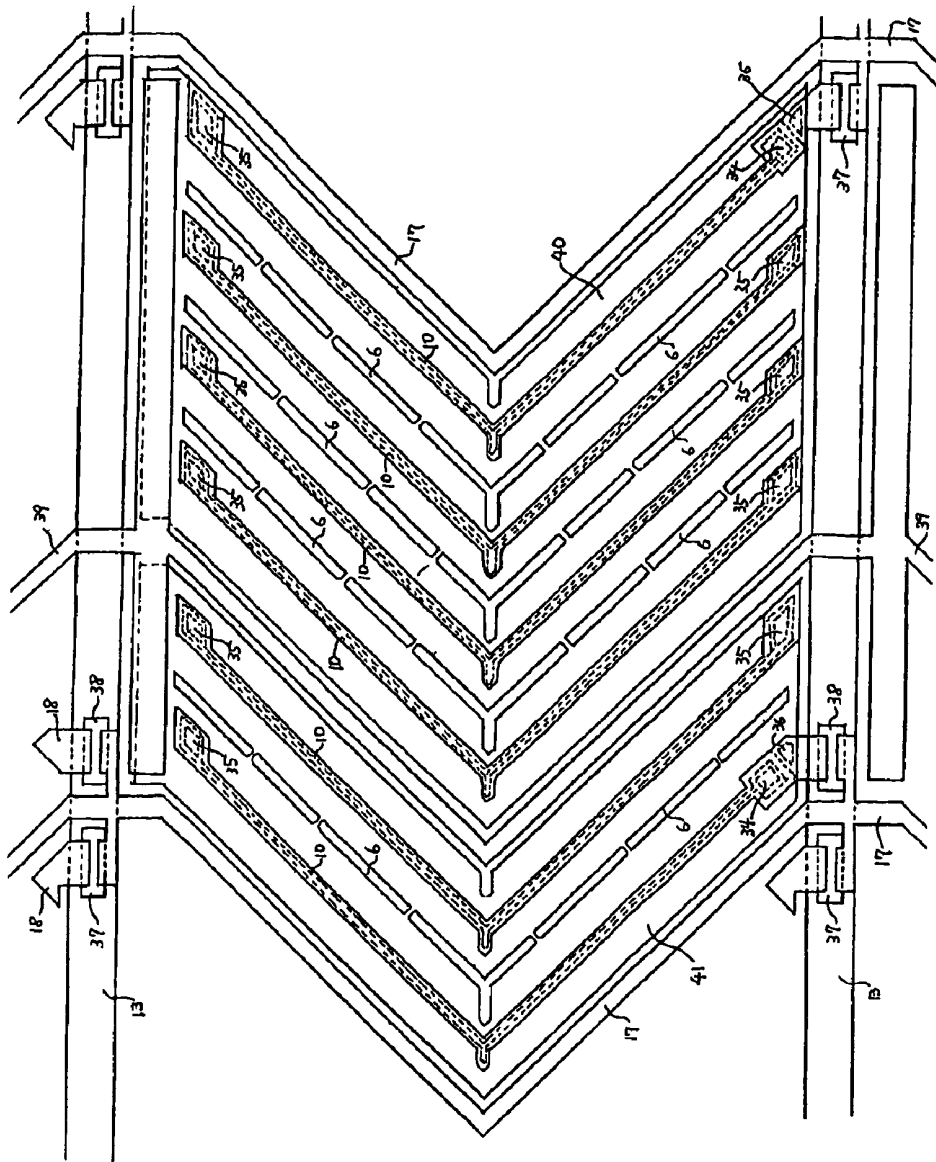

Fig. 22

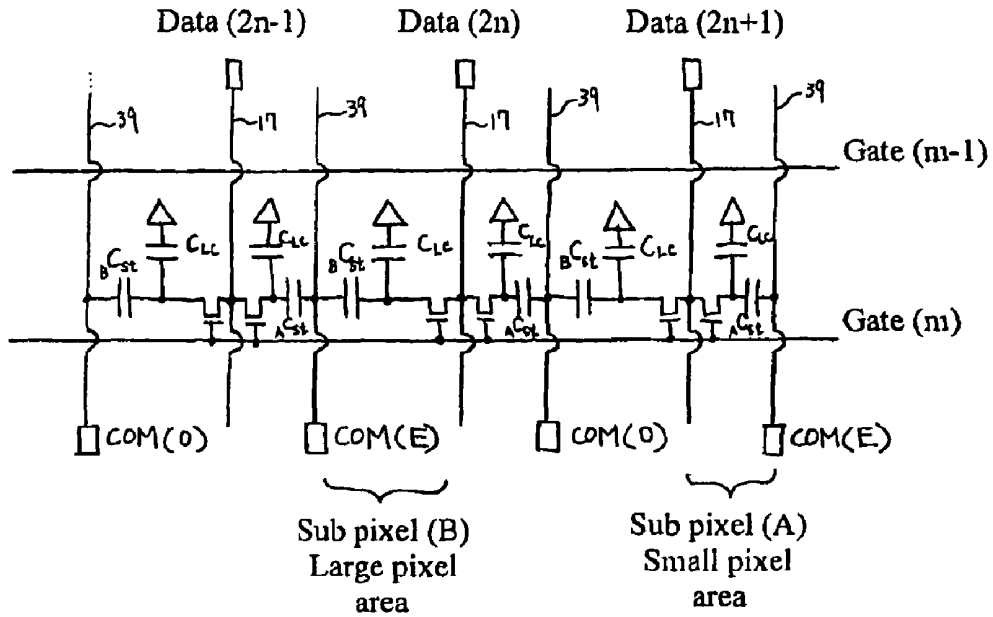

Fig. 23

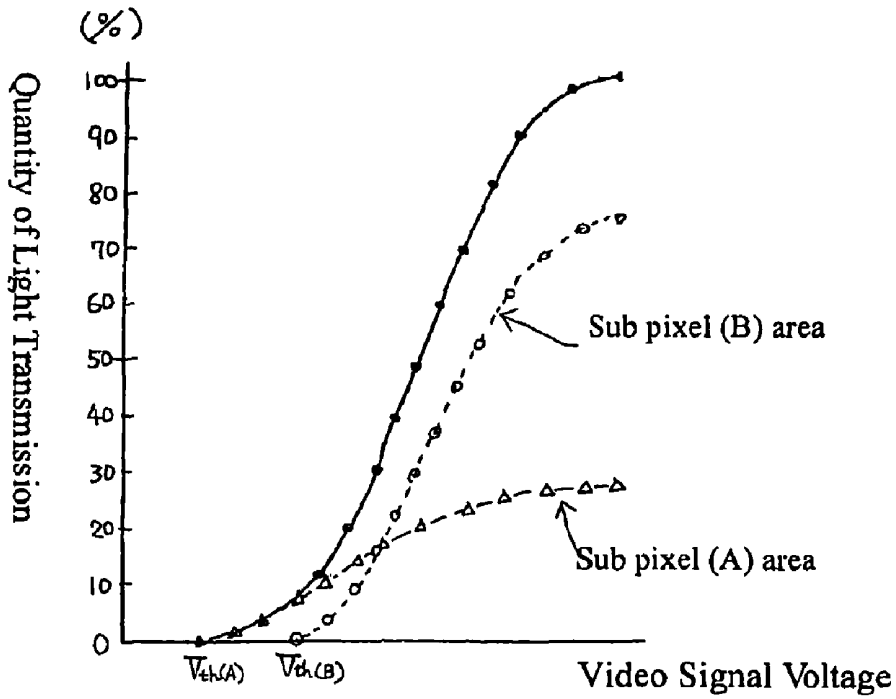

Fig. 24

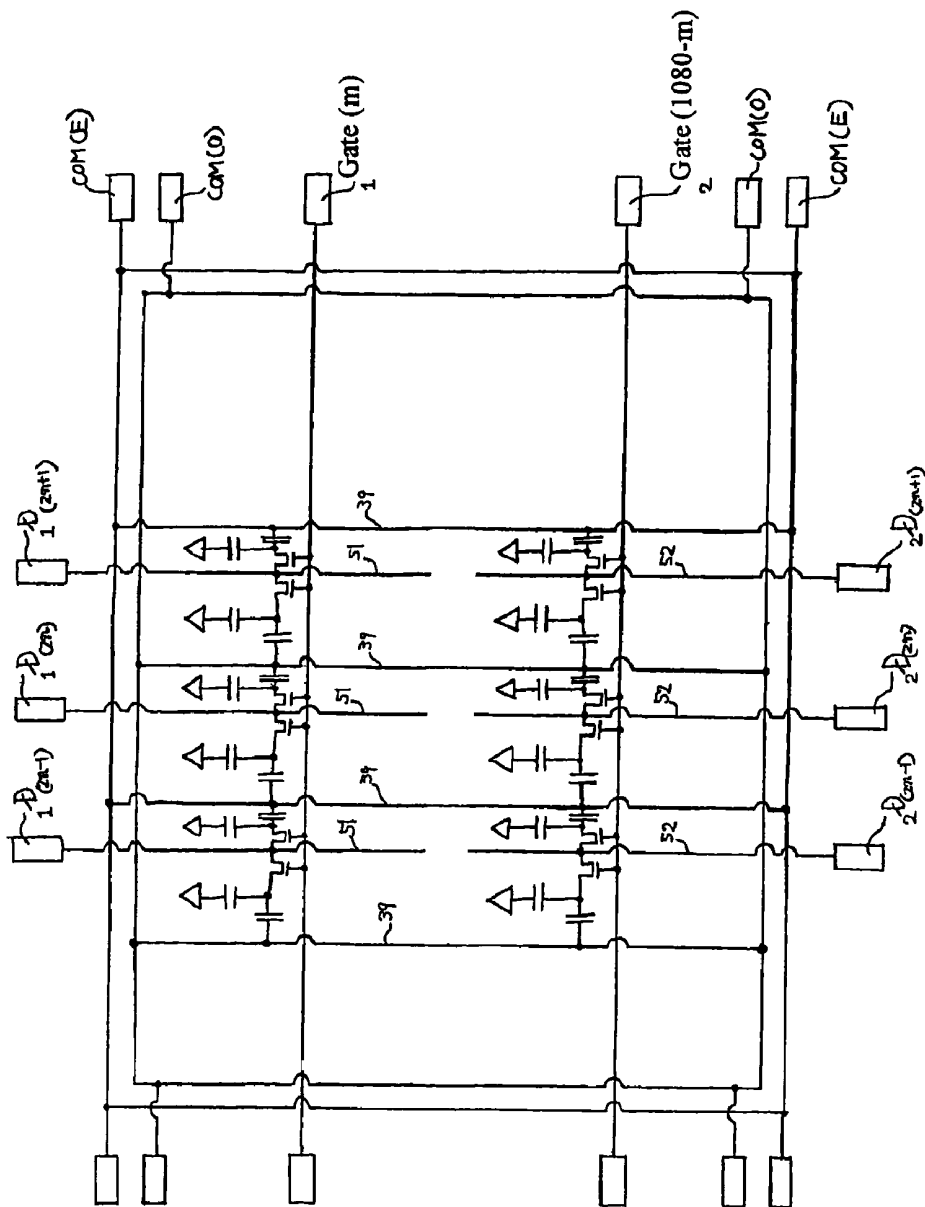

Fig. 25

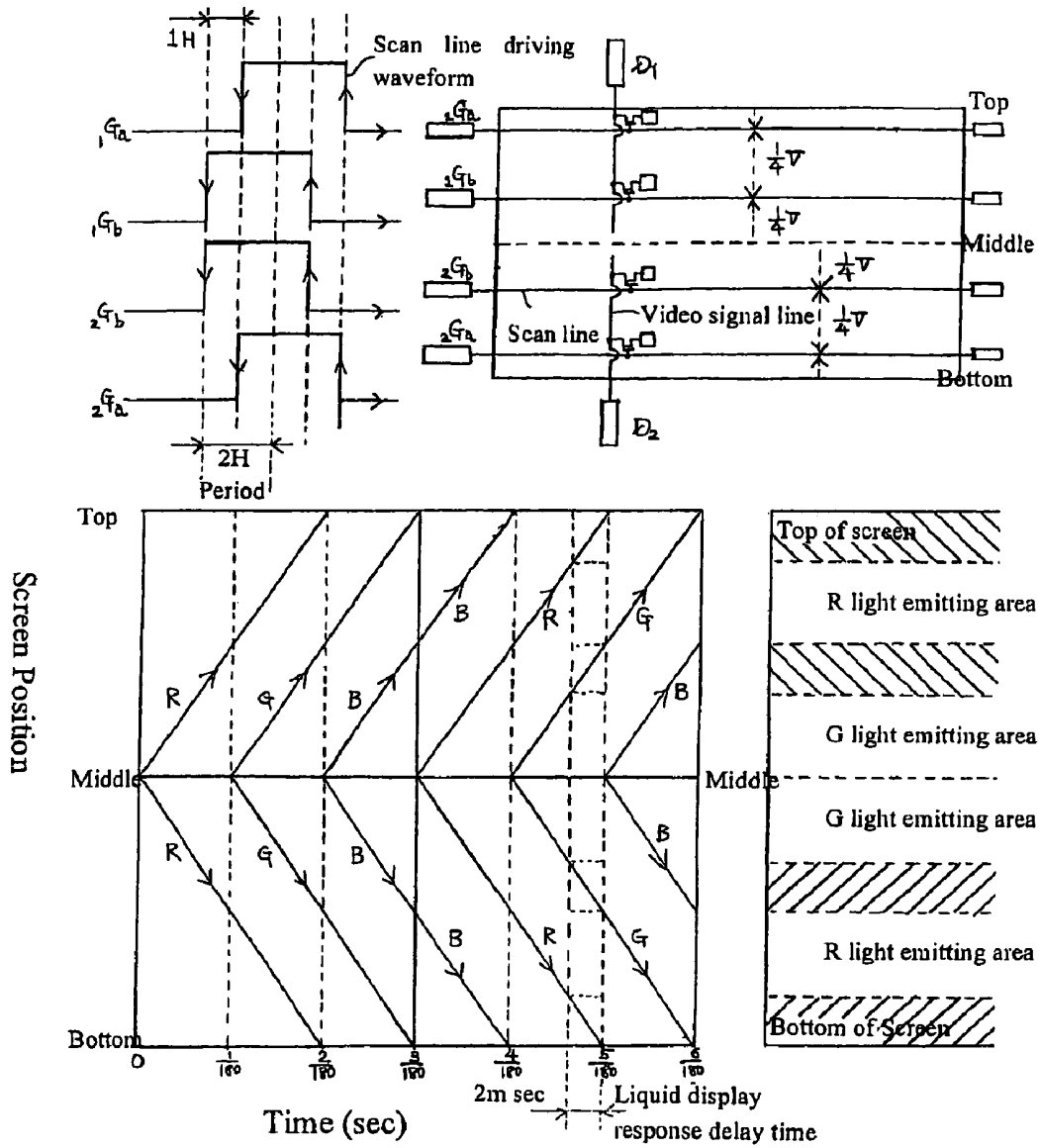

Fig. 26

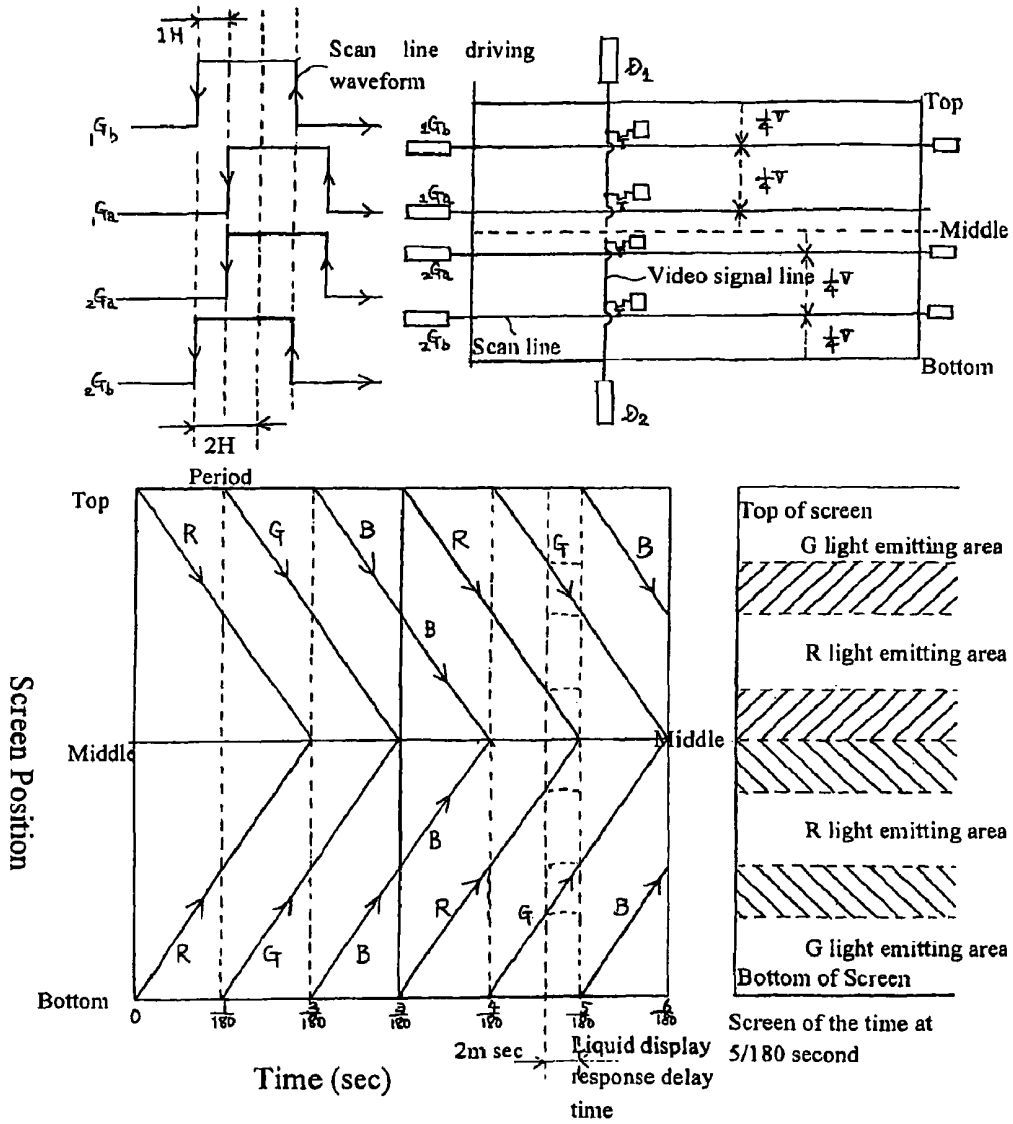

Fig. 27

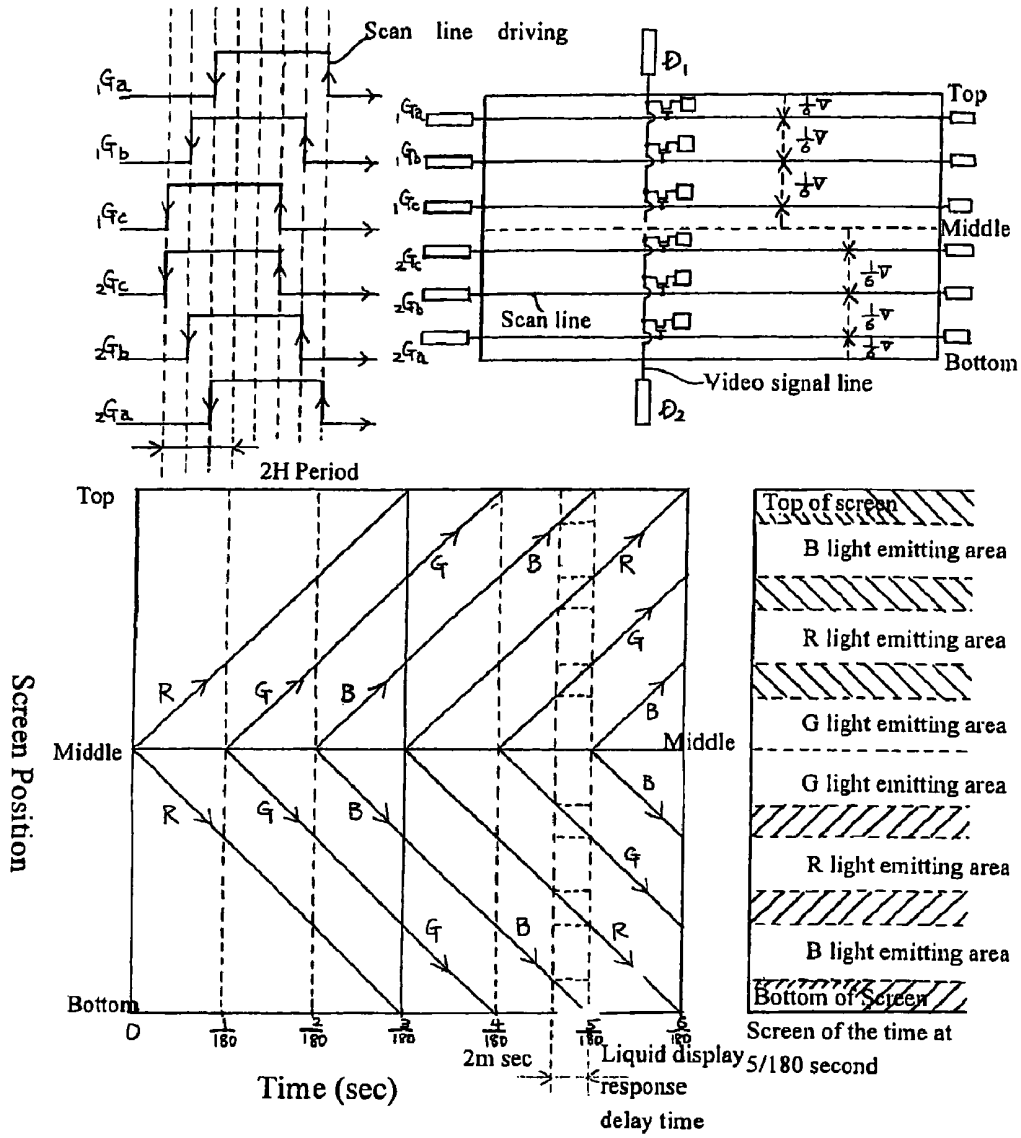

Fig. 28

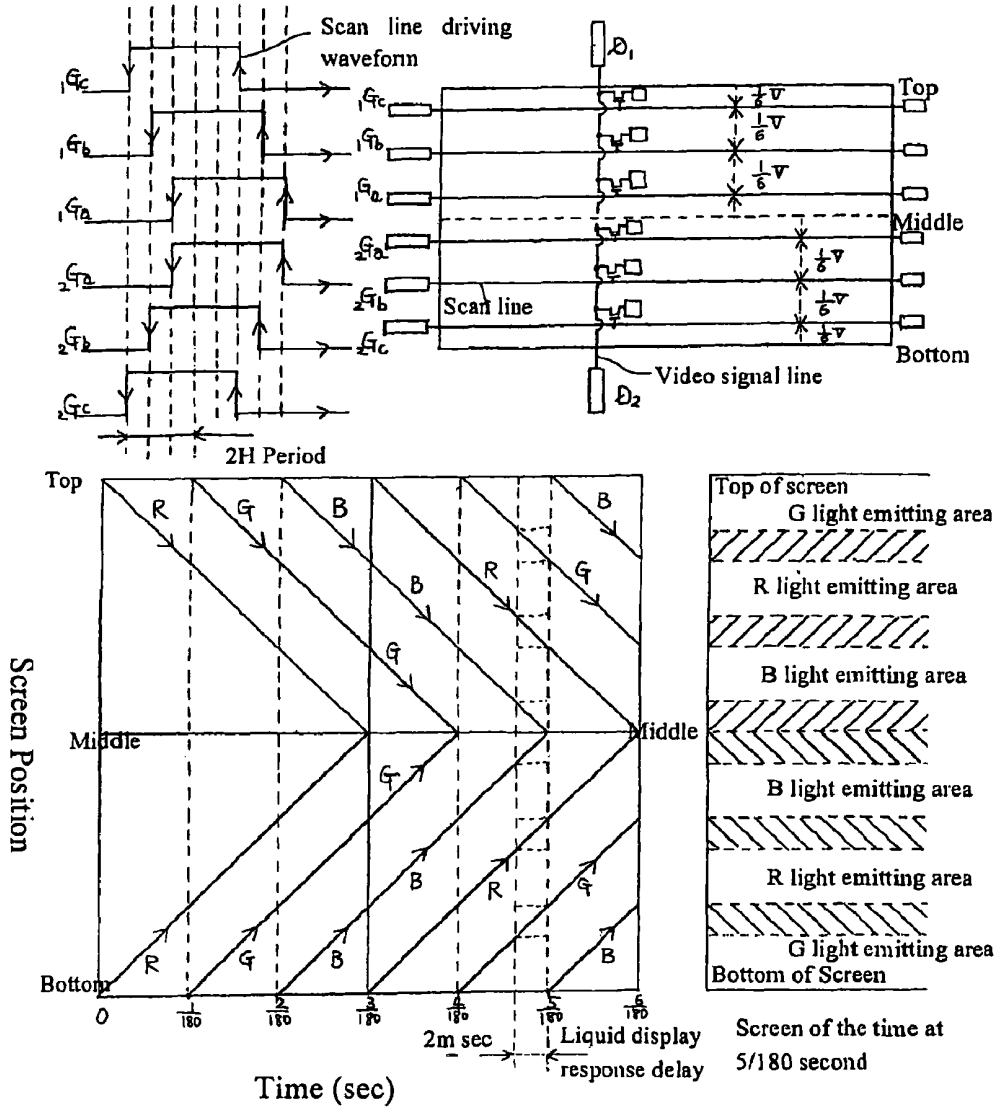

Fig. 29

Photolithographic procedure for 3 times (Halftone exposure for 3 times)

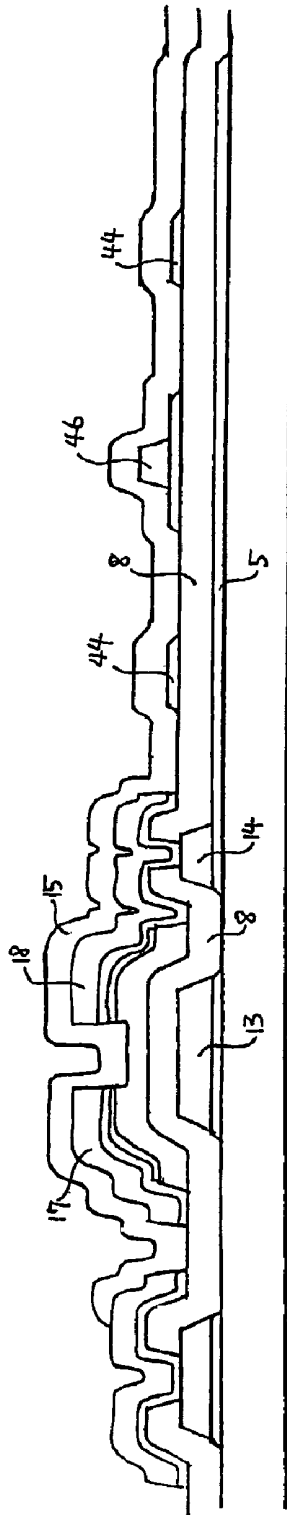

Fig. 33

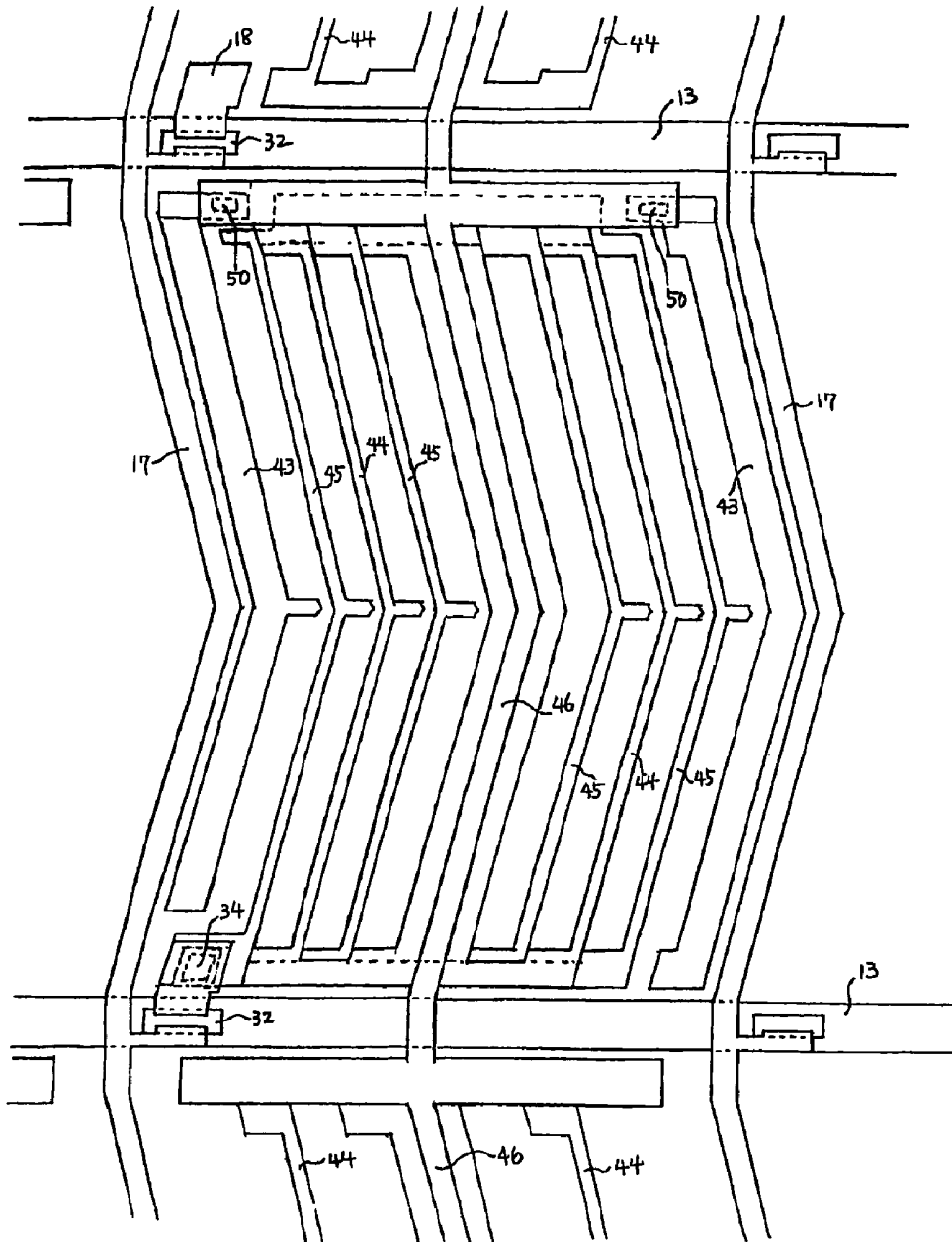

Fig. 34

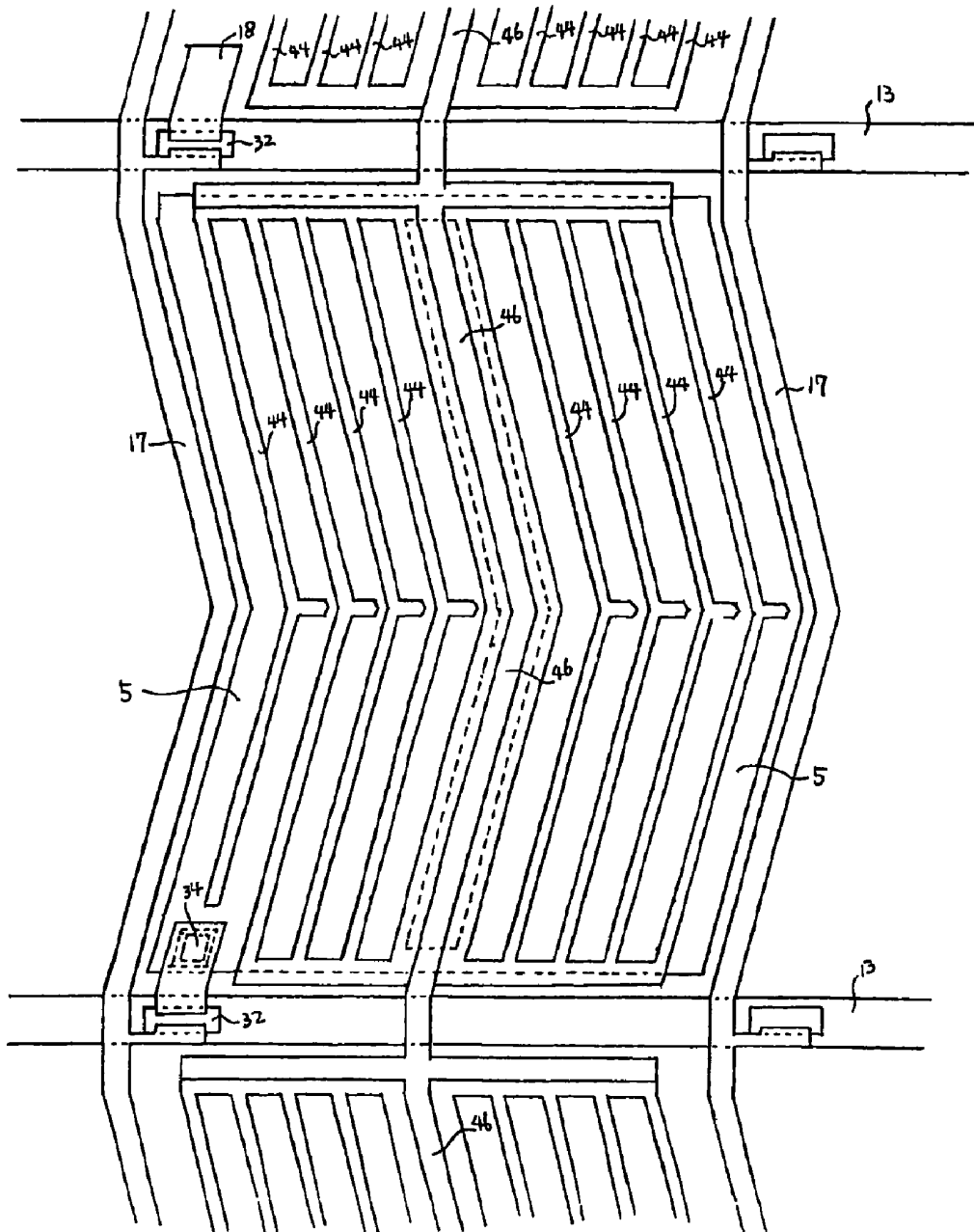

Fig. 35

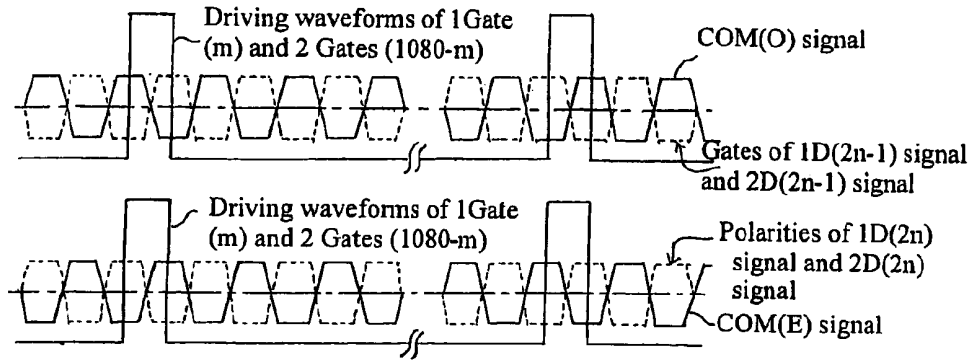

Fig. 36

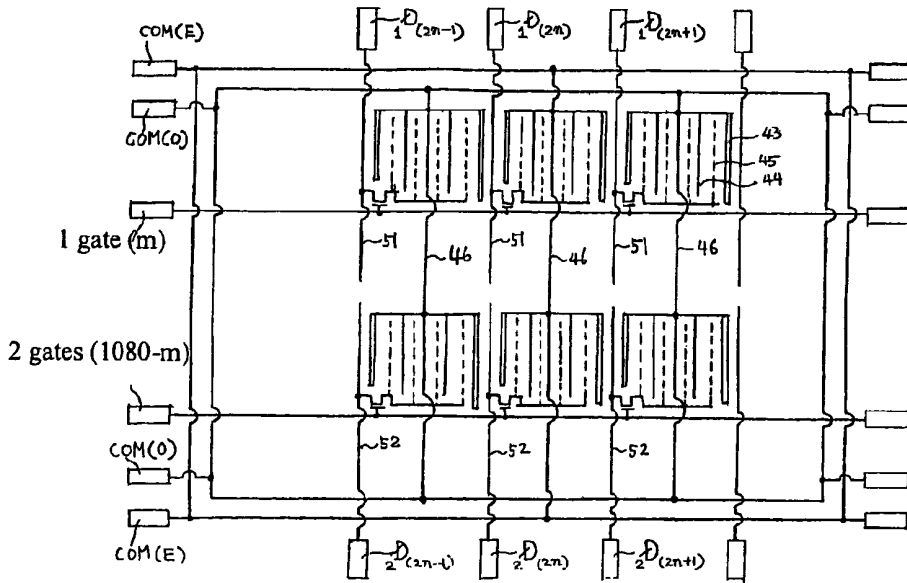

Fig. 37

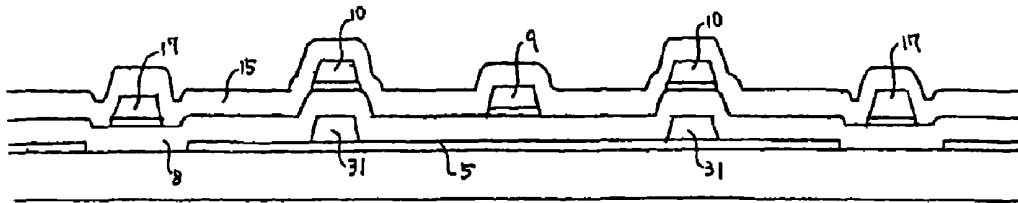

Fig. 38

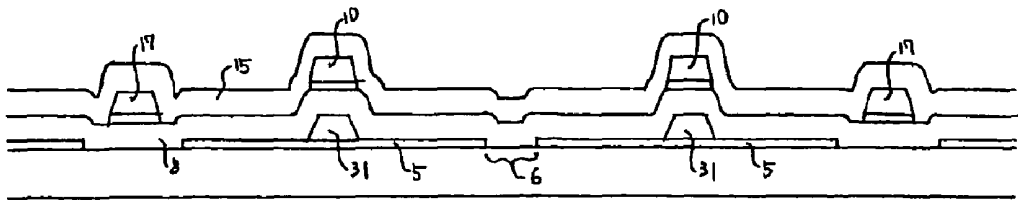

Fig. 39

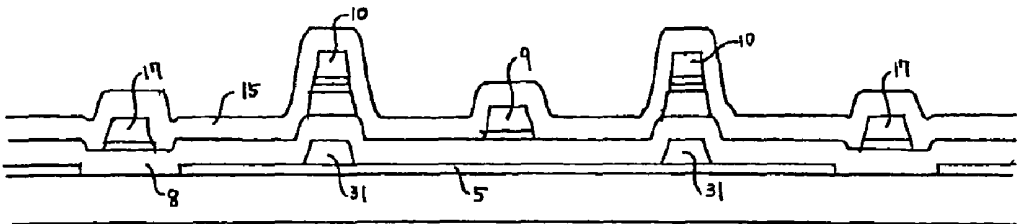

Fig. 40

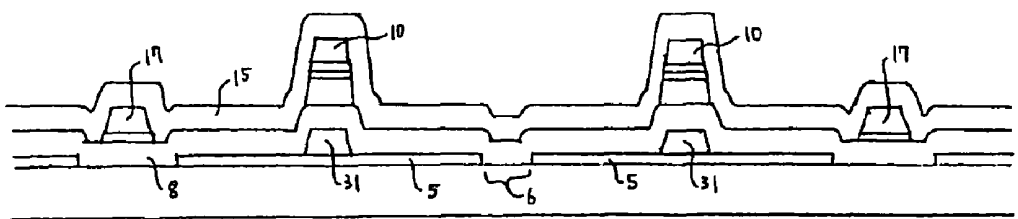

Fig. 41

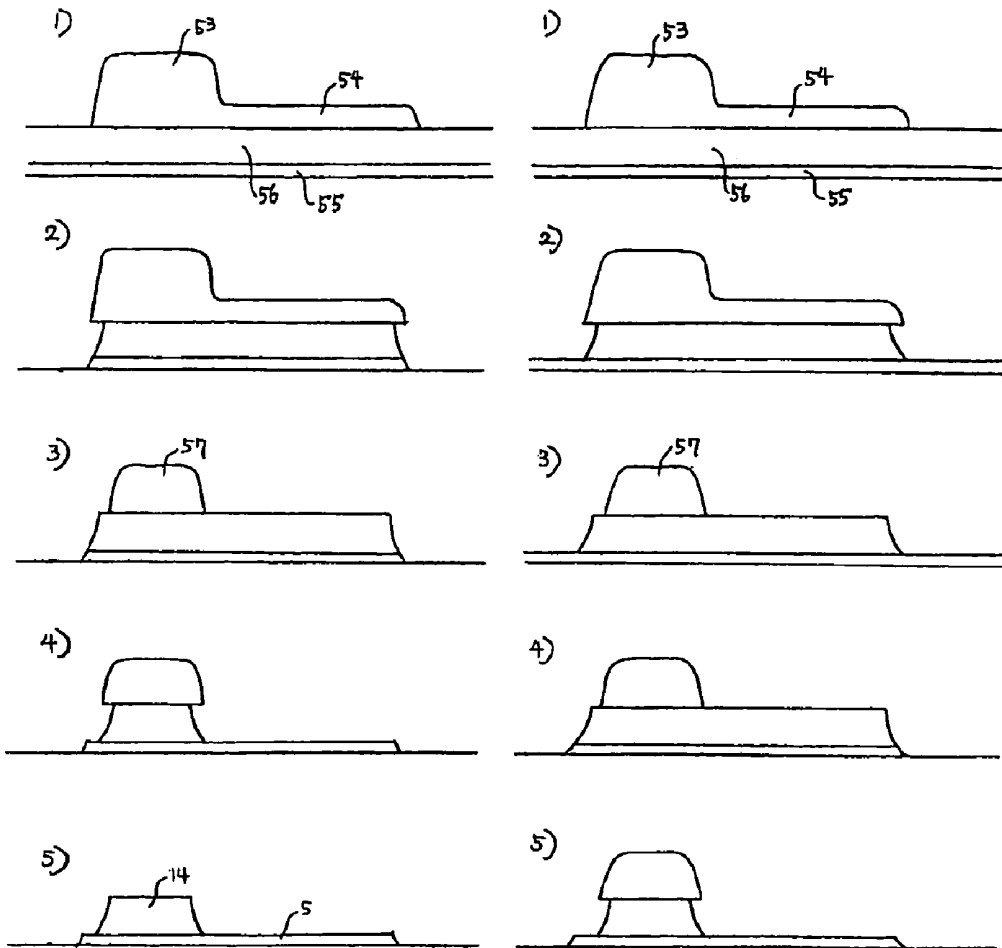

Fig. 42

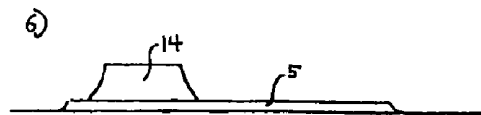

Fig. 43

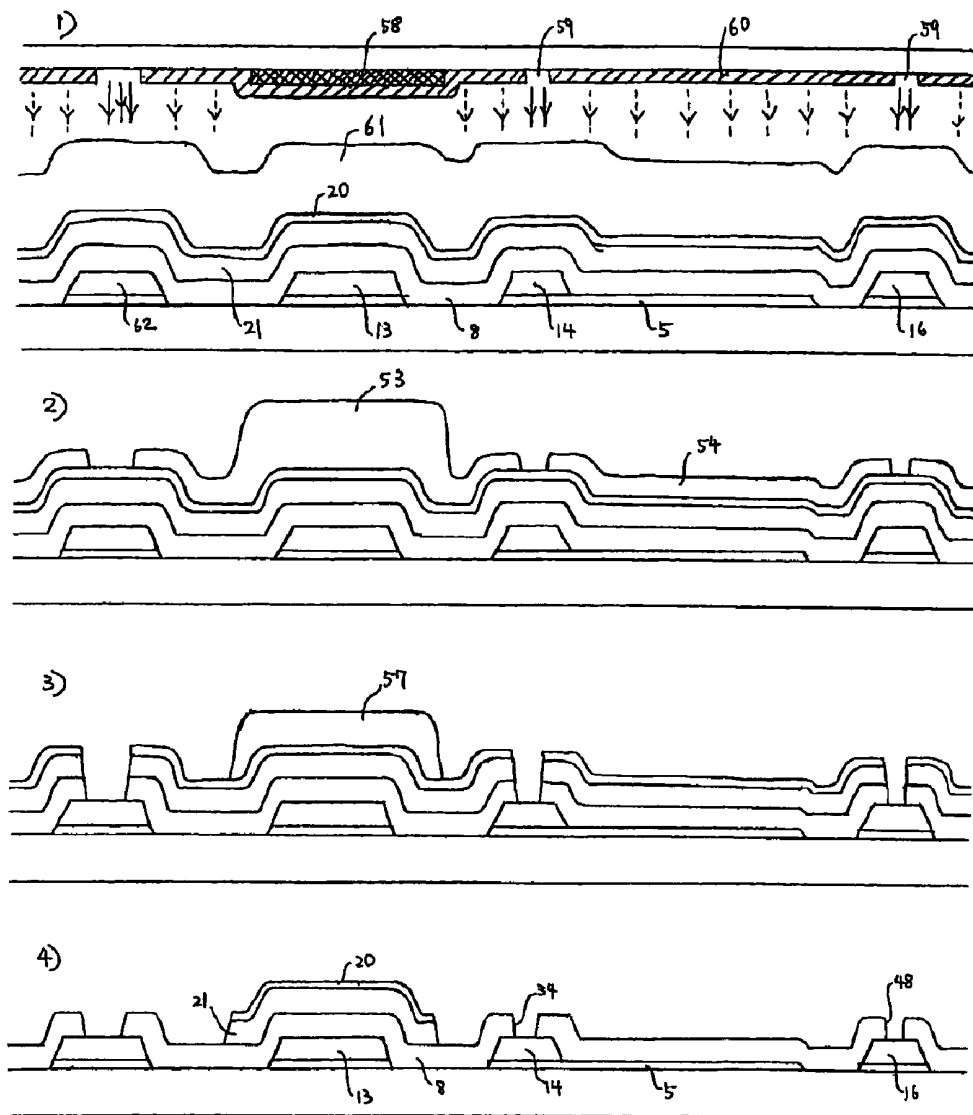

Fig. 44

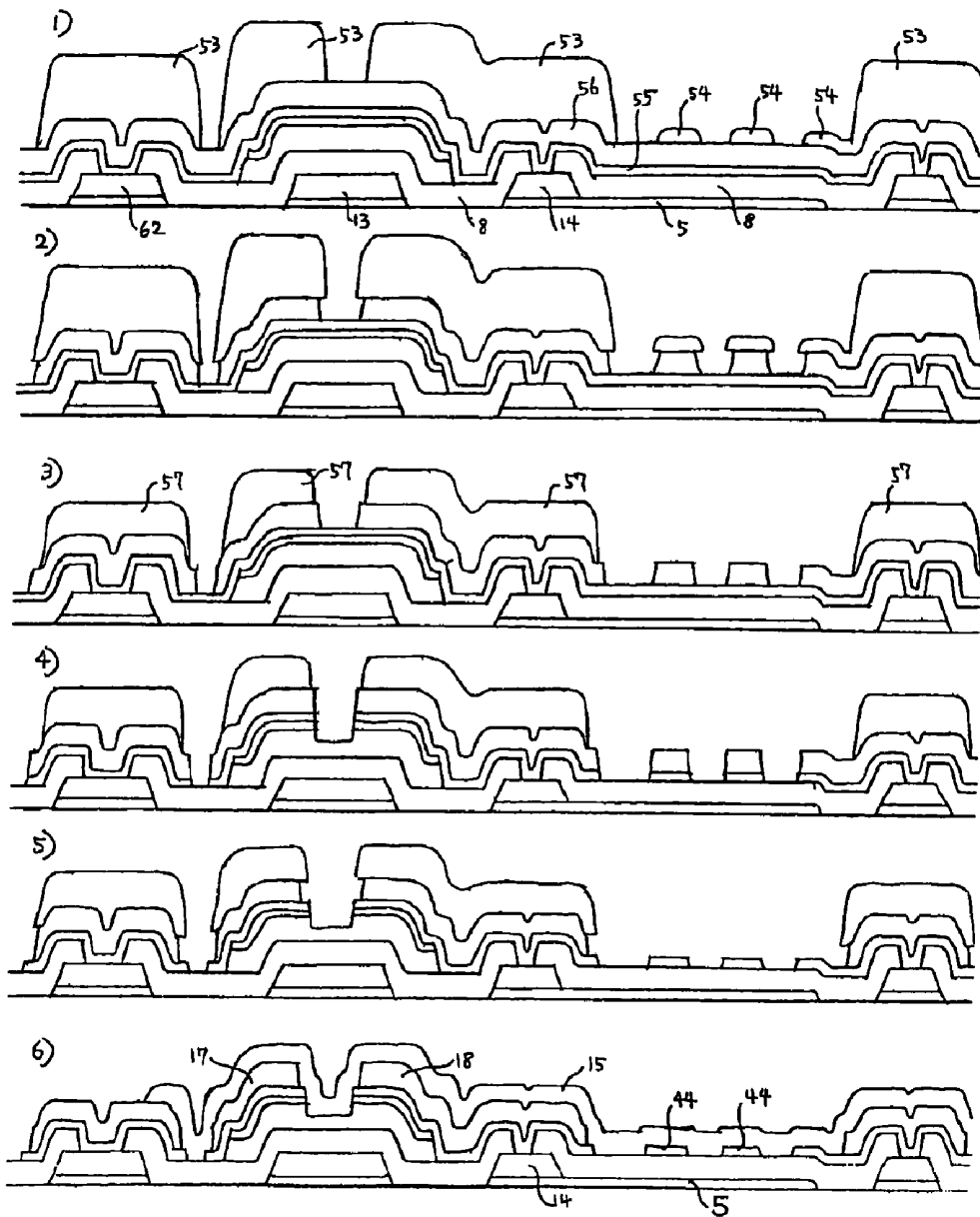

Fig. 45

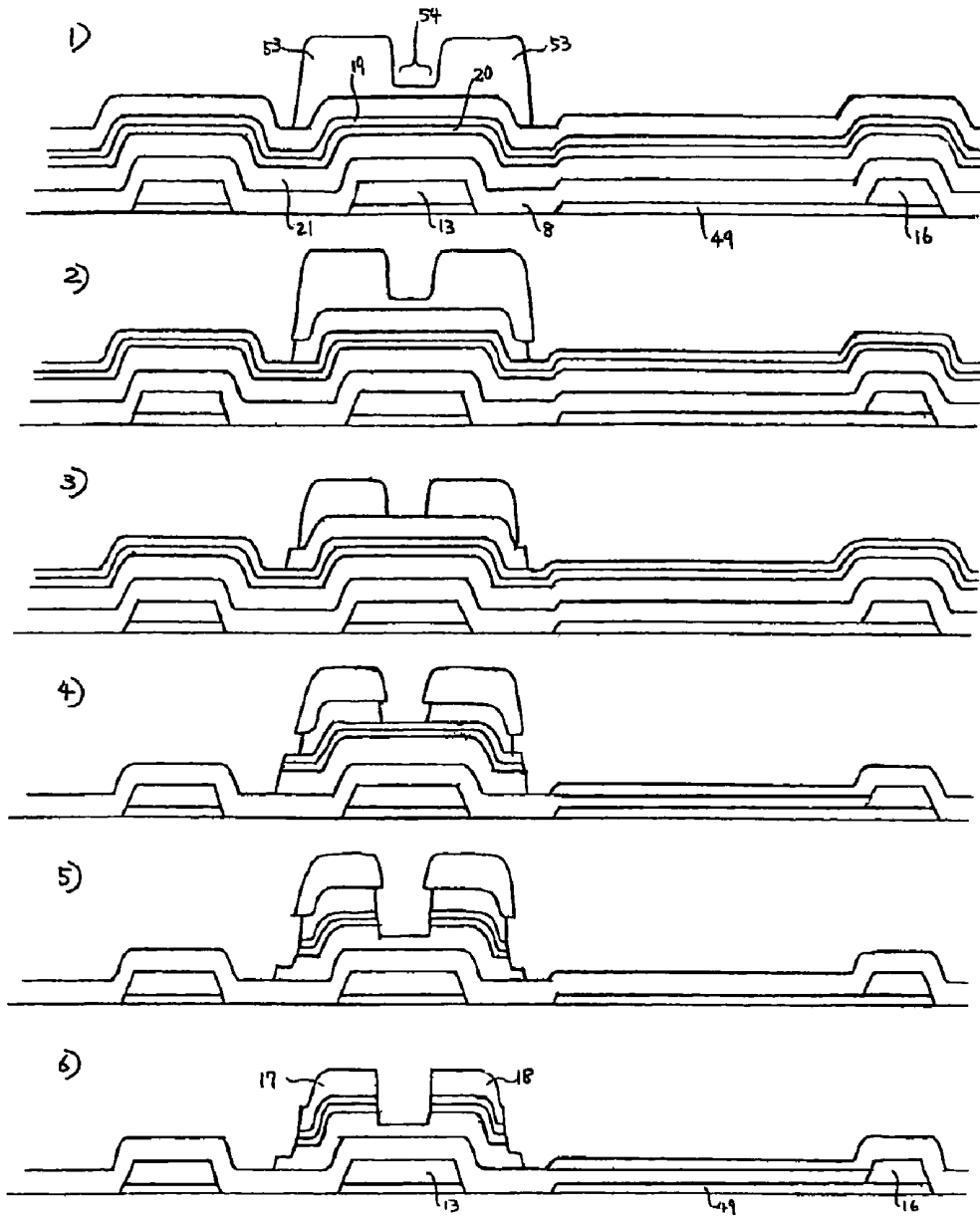

Fig. 46

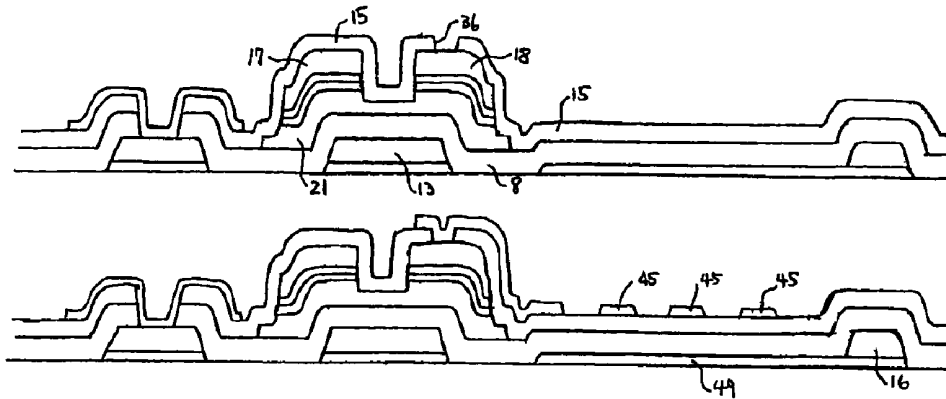

Fig. 47A

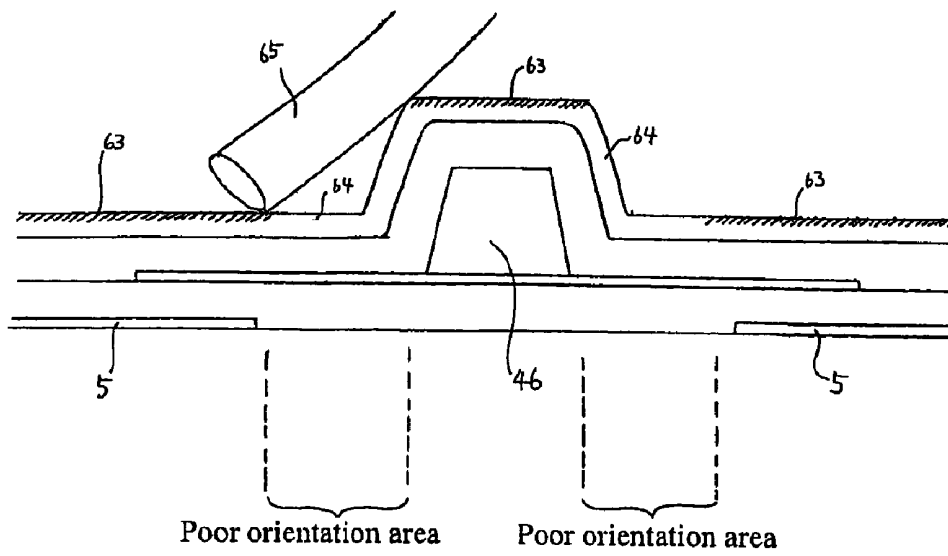

Fig. 47B

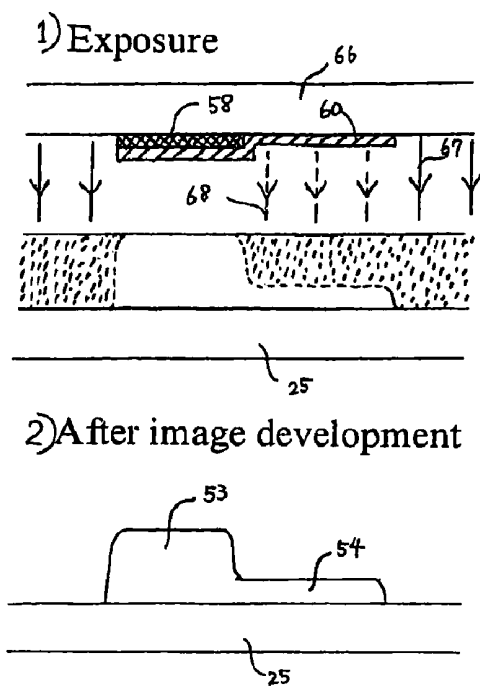

Fig. 48

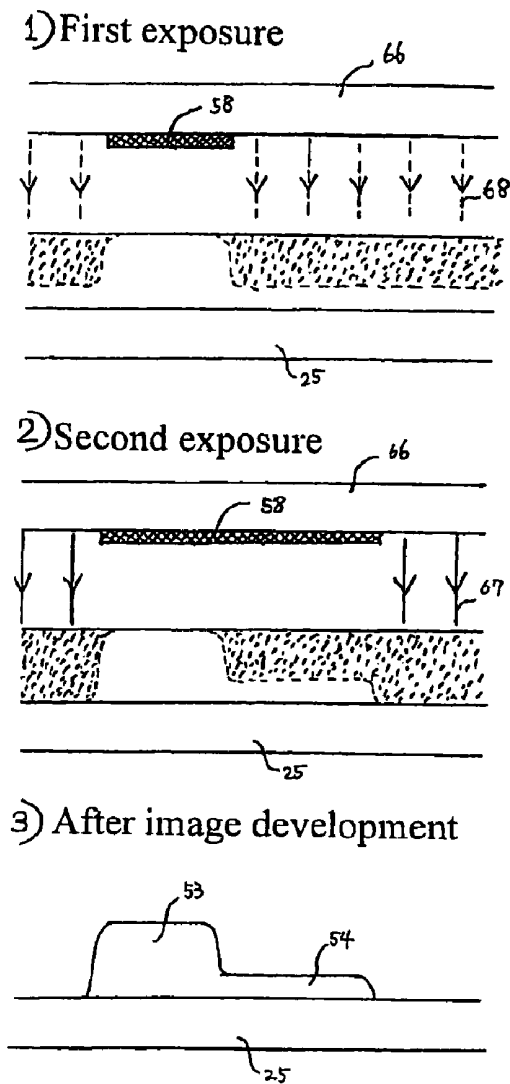

Fig. 49

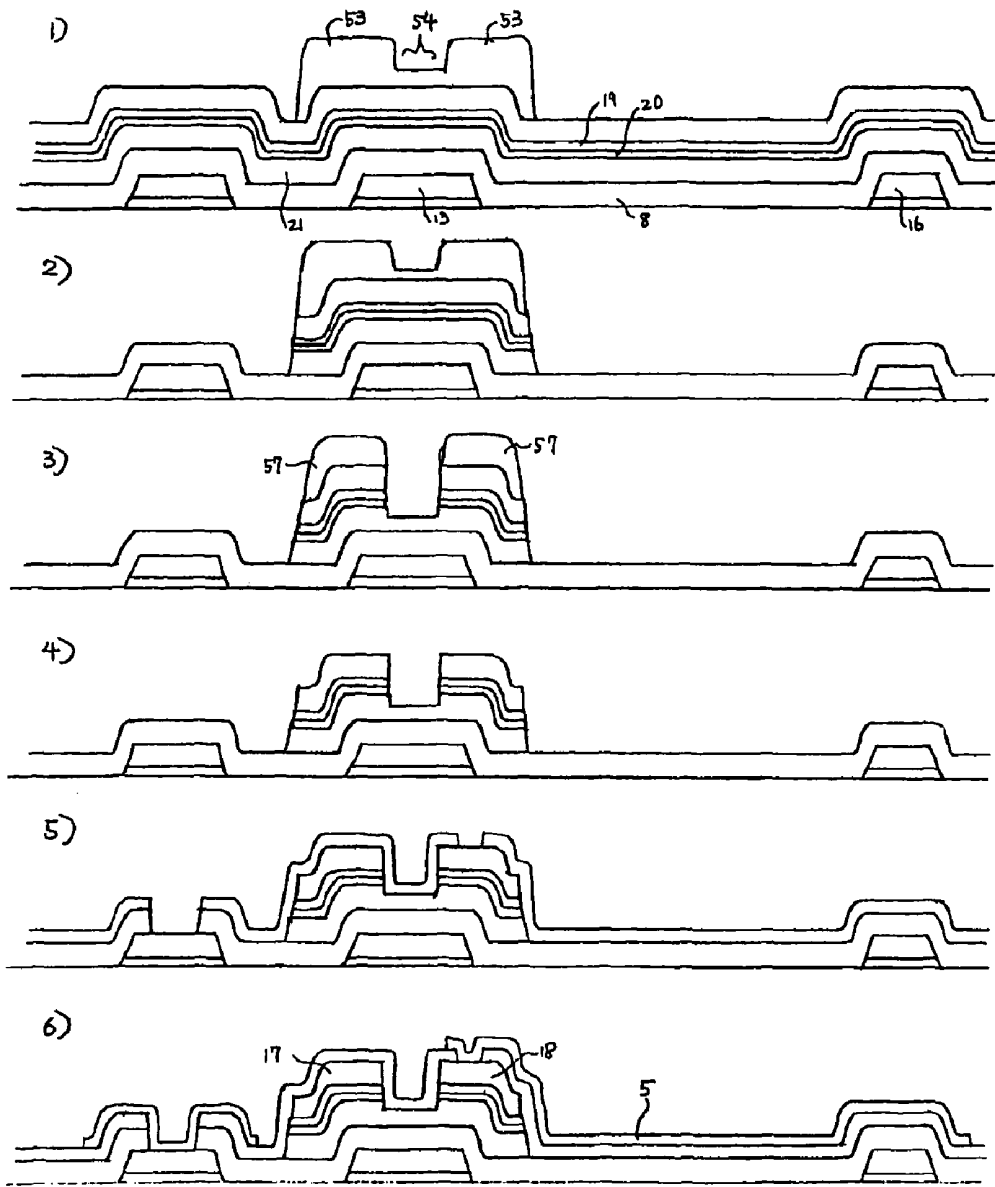

Fig. 50

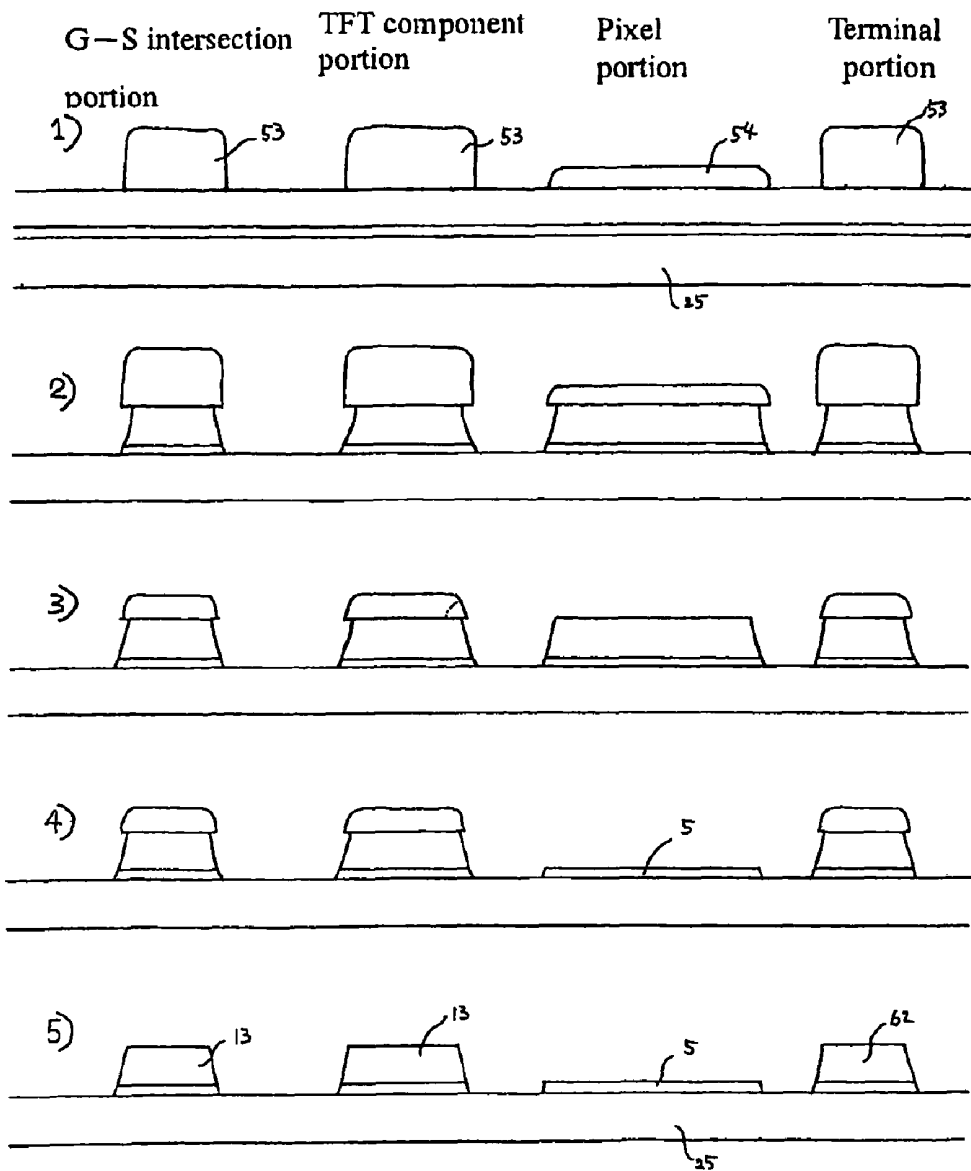

Fig. 51

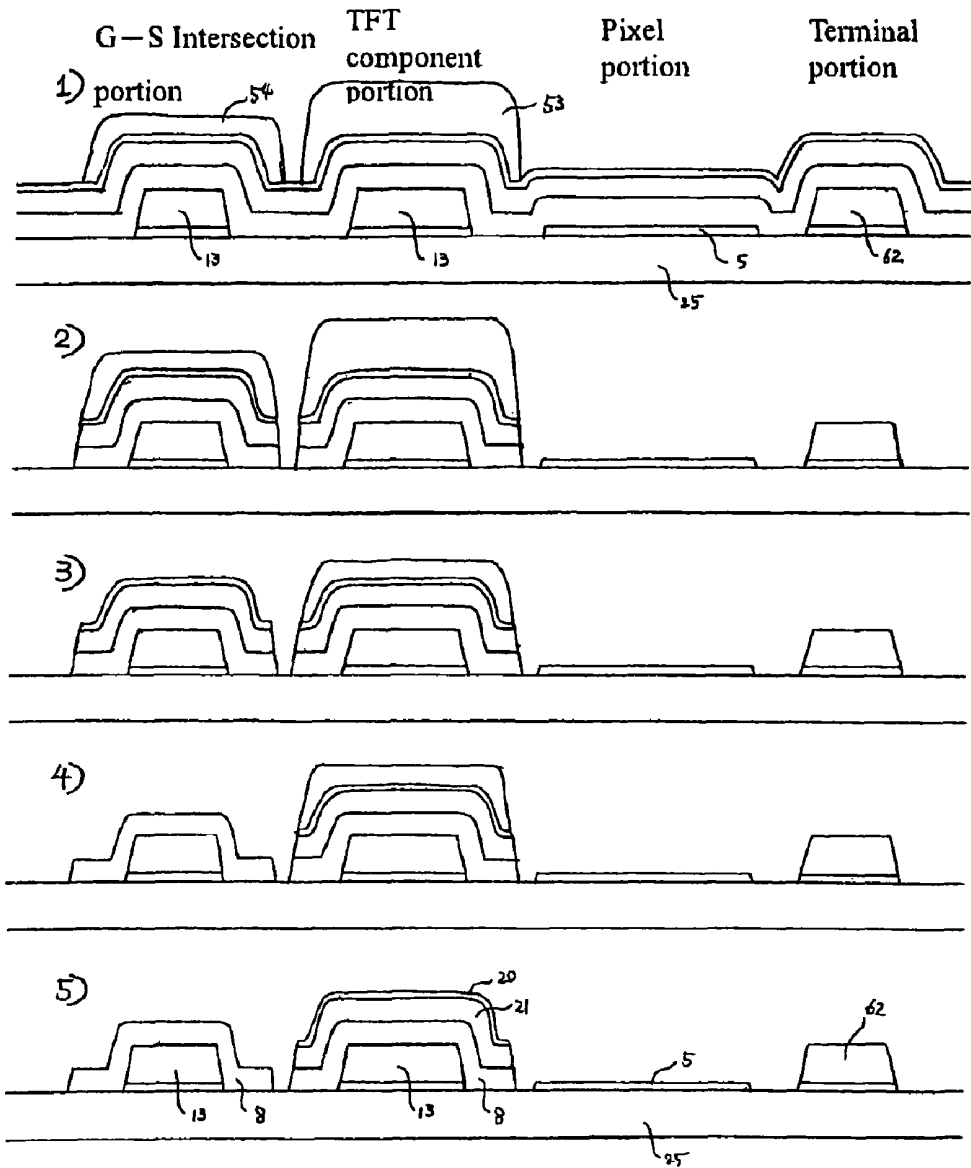

Fig. 52

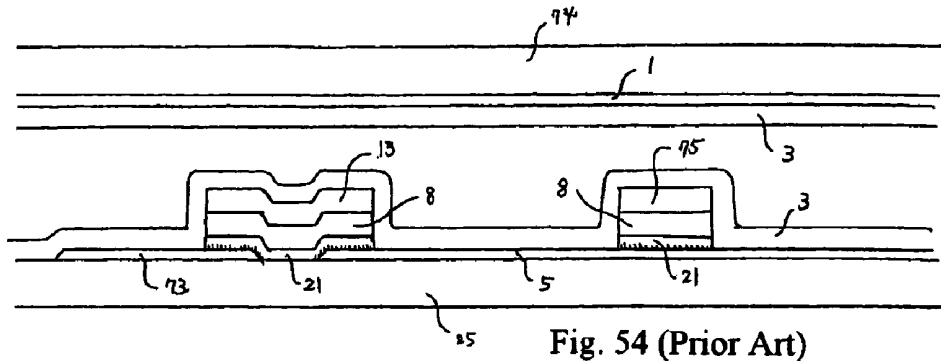

Fig. 54 (Prior Art)

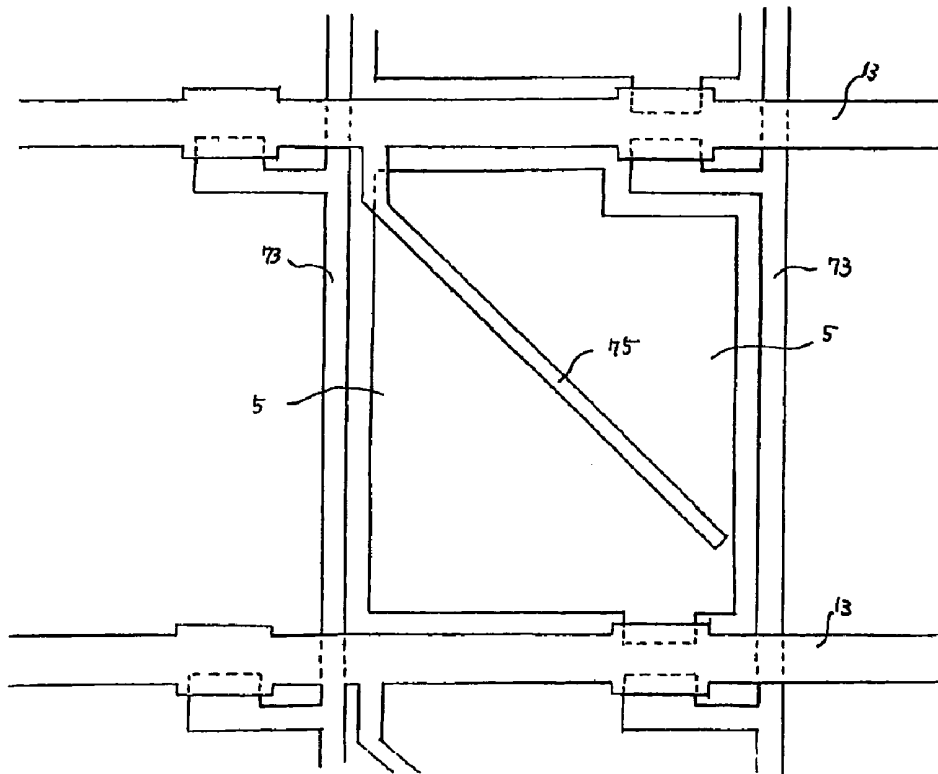

Fig. 55 (Prior Art)

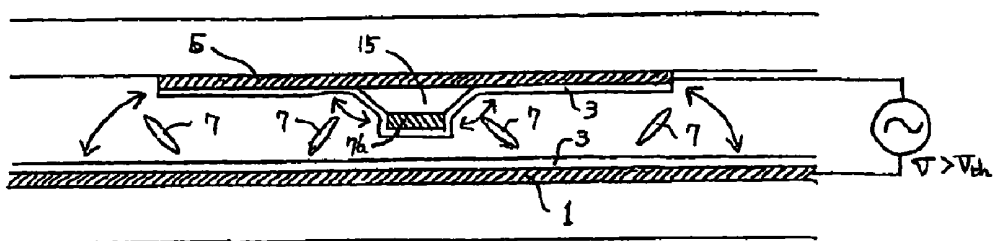

Fig. 56 (Prior Art)

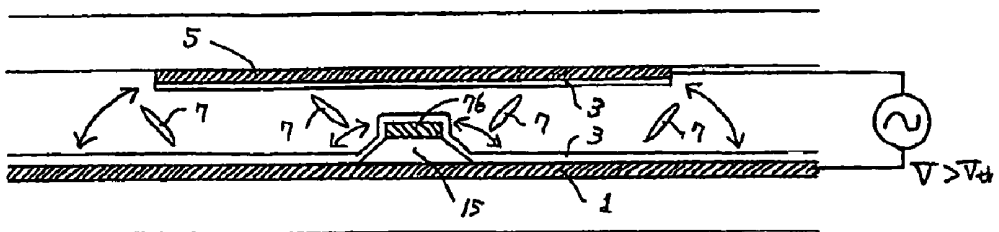

Fig. 57 (Prior Art)

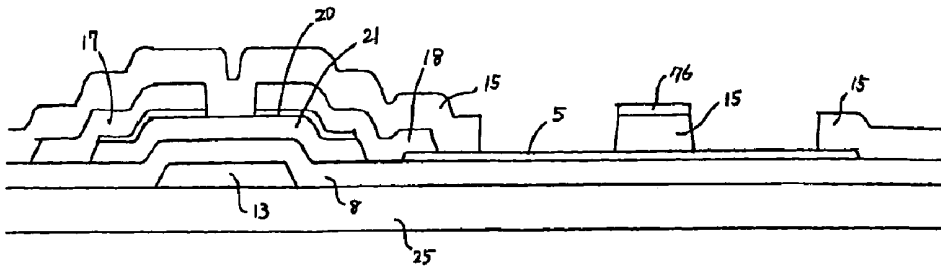

Fig. 58 (Prior Art)

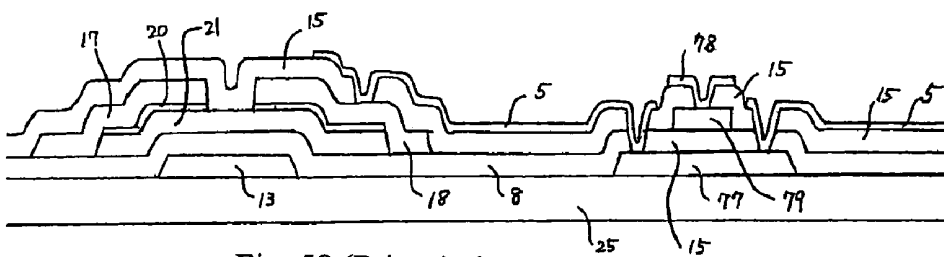

Fig. 59 (Prior Art)

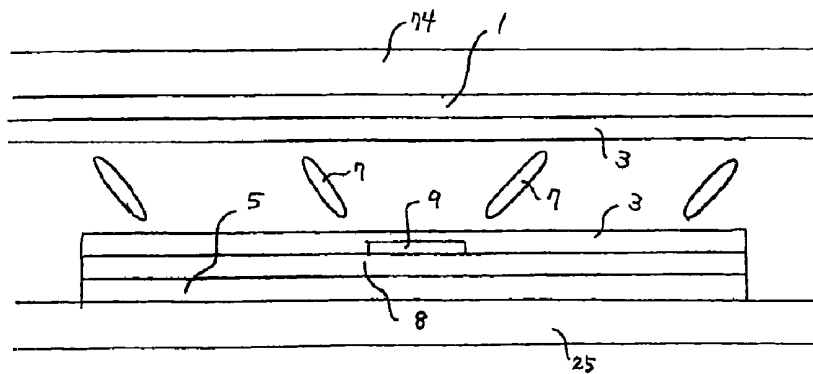

Fig. 60 (Prior Art)

Fig. 61

MVA Mode Using a Photolithographic Procedure for Three Times (A)

- (1) Form a gate electrode, a pixel electrode, a common electrode and a contact pad in the pixel electrode (wherein the photolithographic procedure uses a halftone exposure method for the first time).
- (2) Form a separate thin film semiconductor layer component, and a contact hole (wherein the photolithographic procedure uses a halftone exposure method for the second time).
- (3) Form a source electrode, a drain electrode and an orientation control electrode (wherein the photolithographic procedure uses a general exposure method).

After an ohmic contact layer of a channel portion of the thin film transistor is dry etched, a partial film of a passivation layer is formed by a silicon nitride film by using a mask deposition method (wherein the film is formed at a terminal portion other than those of a gate electrode, a source electrode and a common electrode).

Fig. 62

MVA Mode Using a Photolithographic Procedure for Three Times (B)

- (1) Form a gate electrode, a pixel electrode and a contact pad in the pixel electrode (wherein the photolithographic procedure uses a halftone exposure method for the first time).
- (2) Form a separate thin film semiconductor layer component, and a contact hole (wherein the photolithographic procedure uses a halftone exposure method for the second time).
- (3) Form a source electrode, a drain electrode, an orientation control electrode and a common electrode (wherein the photolithographic procedure uses a general exposure method).

After an ohmic contact layer of a channel portion of the thin film transistor is dry etched, a partial film of a passivation layer is formed by a silicon nitride film by using a mask deposition method (wherein the film is formed at a terminal portion other than those of a gate electrode, a source electrode and a common electrode).

Fig. 63

IPS Mode Using a Photolithographic Procedure for Three Time (C)

- (1) Form a gate electrode, a comb pixel electrode, a common electrode for shielding a video signal line (or a source electrode), a contact pad in the pixel electrode, and a video signal line for shielding the contact pad in common electrode (wherein the photolithographic procedure uses a halftone exposure method for the first time).
 - (2) Form a separate thin film semiconductor layer component, and a contact hole (wherein the photolithographic procedure uses a halftone exposure method for the second time).
 - (3) Form a source electrode (or video signal line), a drain electrode, a common electrode at the center of a pixel and a comb common electrode (wherein the third time of photolithographic procedure uses a halftone exposure method).
- After an ohmic contact layer of a channel portion of the thin film transistor is dry etched, a partial film of a passivation layer is formed by a silicon nitride film by using a mask deposition method (wherein the film is formed at a terminal portion other than those of a gate electrode, a source electrode and a common electrode).

Fig. 64

FFS Mode Using a Photolithographic Procedure for Three Times (D)

- (1) Form a gate electrode, a pixel electrode and a contact pad in the pixel electrode (wherein a first time of applying the photolithographic procedure adopts a halftone exposure method).
- (2) Form a separate thin film semiconductor layer component, and a contact hole (wherein a second time of applying the photolithographic procedure adopts a halftone exposure method).
- (3) Form a source electrode (or a video signal line), a drain electrode, a common electrode at the center of a pixel and a comb common electrode (wherein a third time of applying the photolithographic procedure adopts a halftone exposure method).

After an ohmic contact layer of a channel portion of the thin film transistor is dry etched, a partial film of a passivation layer is formed by a silicon nitride film by using a mask deposition method (wherein the film is formed at a terminal portion other than those of a gate electrode, a source electrode and a common electrode).

**METHOD OF FABRICATING A
MULTI-DOMAIN VERTICAL ALIGNMENT
(MVA) LIQUID CRYSTAL DISPLAY**

RELATED APPLICATIONS

This application is a divisional application claiming priority to Ser. No. 11/743,749, filed on May 3, 2007.

FIELD OF THE INVENTION

The present invention relates to a large-screen wide-angle liquid crystal display apparatus manufactured by using a halftone exposure method.

BACKGROUND OF THE INVENTION

In multi-domain vertical alignment (MVA) liquid crystal display apparatuses, an alignment control electrode for controlling an alignment of a liquid crystal molecule has been disclosed in Japan Laid Open Patents Nos. 07-230097, 11-109393 and 2001-042347.

SUMMARY OF THE INVENTION

In view of the shortcomings of the prior art, the inventor of the present invention based on years of experience in the related industry conducting research and experiments, finally developed a large-screen wide-angle liquid crystal display apparatus in accordance with the present invention to overcome the foregoing shortcomings.

Therefore, it is a primary objective of the present invention to adopt a prior art alignment control electrode of a liquid crystal display (LCD) panel structure to correspond to smaller pixels. Because only one type of alignment control electrode is used, and the edge field effect of a pixel electrode is adopted, it is not applicable for larger pixels.

At present, the mainstream of multi-domain vertical alignment (MVA) liquid crystal display apparatus generally uses a bump or slit electrode for the alignment control of the sides of a color filter (CF) substrate, and this method can make a proper alignment if the pixel is large, but the cost of CF substrates is high, and becomes an obstacle for manufacturing a large-screen liquid crystal TV by a low cost.

Therefore, it is a primary objective of the present invention to reduce the number of photolithographic procedures of the thin film transistor (TFT) active matrix substrate and the CF substrate during the manufacture of the TFT active matrix liquid crystal display apparatus in order to shorten the manufacturing procedure, lowering the manufacturing cost, and improving the yield rate.

The technical measures taken by the present invention are described as follows.

In Measure 1, unstable and swinging discrimination lines are avoided, and two types of alignment control electrodes are installed at an upper layer of a pixel electrode through an insulating film, and between common electrodes corresponding to the pixel electrodes. With the foregoing two different types of alignment control electrodes, the oblique direction of anisotropic liquid crystal molecules having a negative dielectric constant can be controlled precisely.

In Measure 2, one type of alignment control electrode is installed at an upper layer of a pixel electrode through an insulating film, and a slender slit is formed in the pixel electrode, and these two alignment control mechanisms can control the oblique direction of anisotropic liquid crystal molecules having a negative dielectric constant precisely.

In Measure 3, the alignment control electrodes as used in Measures 1 and 2 are connected to the pixel electrodes as close to the substrate as possible.

In Measure 4, the alignment control mechanisms as used in Measures 1 and 2 provide four perfect area alignments for a curvature of 90 degrees at a position proximate to the center of the pixel.

In Measure 5, a halftone exposure method is introduced into the manufacturing process of the TFT array substrate to reduce the number of photolithographic procedures.

In Measure 6, a basic unit pixel is divided into two sub pixels, and the common electrodes are installed parallelly on a video signal line, and the common electrodes of odd-numbered rows and even-numbered rows switch signals with different polarities in each scan period, and produce different voltages applied to the liquid crystal molecules of the two sub pixels.

With Measures 1 and 2, the TFT array substrate has all alignment control functions, and thus it is not necessary to form a pad or slit on the CF substrate for the alignment control, so that the MVA LCD panel can be manufactured with a low-cost CF substrate to lower the cost and improve the yield rate.

With Measure 3, the alignment control electrode connected to the pixel electrode is proximate to the substrate for enhancing the rotational torque of an electric field of anisotropic liquid crystal molecules having negative dielectric constant and acted at the vertical alignment, so as to achieve a high-speed response.

With Measure 4, unnecessary discrimination lines can be avoided to improve the overall light transmission rate of the screen and reduce unevenness of the LCD panel.

With Measures 1, 2 and 5, the processing costs for both CF substrate and TFT array substrate can be lowered, and thus the manufacturing cost of MVA LCD panels can be lowered significantly; the production efficiency can be improved, and the yield rate can be enhanced.

With Measures 5 and 6, the liquid crystal alignment control mechanism can be manufactured by a very simple manufacturing process, and the correction of γ curve can be achieved by a very simple circuit, and thus a little cost is incurred for enhancing the display quality of a MVA liquid crystal display apparatus.

BRIEF DESCRIPTION OF THE DRAWINGS

FIG. 1 is a cross-sectional view of a conventional MVA LCD panel;

FIG. 2 is a cross-sectional view of a conventional MVA LCD panel;

FIG. 3 is a cross-sectional view of a MVA LCD panel of the present invention;

FIG. 4 is a cross-sectional view of a MVA LCD panel of the present invention;

FIG. 5 is a schematic view of the principle of a MVA LCD panel of the present invention;

FIG. 6 is a schematic view of the principle of a MVA LCD panel of the present invention;

FIG. 7 is a schematic view of the principle of a MVA LCD panel of the present invention;

FIG. 8 is a cross-sectional view of a MVA LCD panel adopting a TFT matrix substrate in accordance with the present invention;

FIG. 9 is a cross-sectional view of a TFT array substrate used for a MVA LCD panel in accordance with the present invention;

FIG. 10 is a cross-sectional view of a TFT array substrate used for a MVA LCD panel in accordance with the present invention;

FIG. 11 is a cross-sectional view of a TFT array substrate used in a MVA LCD panel in accordance with the present invention;

FIG. 12 is a cross-sectional view of a TFT array substrate used in a MVA LCD panel in accordance with the present invention;

FIG. 13 is a cross-sectional view of a TFT array substrate used in a MVA LCD panel in accordance with the present invention;

FIG. 14 is a cross-sectional view of a TFT array substrate used in a MVA LCD panel in accordance with the present invention;

FIG. 15 is a planar view of a TFT array substrate used in a MVA LCD panel in accordance with the present invention;

FIG. 16 is a planar view of a TFT array substrate used in a MVA LCD panel in accordance with the present invention;

FIG. 17 is a planar view of a TFT array substrate used in a MVA LCD panel in accordance with the present invention;

FIG. 18 is a planar view of a TFT array substrate used in a MVA LCD panel in accordance with the present invention;

FIG. 19 is a planar view of a TFT array substrate used in a MVA LCD panel in accordance with the present invention;

FIG. 20 is a planar view of a TFT array substrate used in a MVA LCD panel in accordance with the present invention;

FIG. 21 is a planar view of a TFT array substrate used in a MVA LCD panel in accordance with the present invention;

FIG. 22 is a planar view of a TFT array substrate used in a MVA LCD panel in accordance with the present invention;

FIG. 23 shows a circuit model of a TFT array substrate of field-order driven MVA LCD panel in accordance with the present invention;

FIG. 24 shows a relation between the brightness and the signal voltage applied to a MVA LCD panel as depicted in FIG. 23;

FIG. 25 shows a circuit model of a TFT array substrate that is divided into upper and lower field-order driven MVA LCD panels in accordance with the present invention;

FIG. 26 illustrates a field-order driving method that divides a screen into upper and lower sections and writes data from the center of the screen to the upper or lower section of the screen in accordance with the present invention;

FIG. 27 illustrates a field-order driving method that divides a screen into upper and lower sections and writes data from the upper or lower sections of the screen towards the center of the screen in accordance with the present invention;

FIG. 28 illustrates a field-order driving method that divides a screen into upper and lower sections and writes data from the center of the screen to the upper or lower section of the screen in accordance with the present invention;

FIG. 29 illustrates a field-order driving method that divides a screen into upper and lower sections and writes data from the upper or lower sections of the screen towards the center of the screen in accordance with the present invention;

FIG. 30 is a cross-sectional view of a basic unit pixel of a TFT array substrate of a horizontal electric field LCD panel in accordance with the present invention;

FIG. 31 is a cross-sectional view of a basic unit pixel of a TFT array substrate of a horizontal electric field LCD panel in accordance with the present invention;

FIG. 32 shows a circuit model of a circuit of a TFT array substrate of a field-order driven horizontal electric field LCD panel in accordance with the present invention;

FIG. 33 is a cross-sectional view of a TFT array substrate of a horizontal electric field LCD panel in accordance with the present invention;

FIG. 34 is a planar view of a TFT array substrate of a horizontal electric field LCD panel in accordance with the present invention;

FIG. 35 is a planar view of a TFT array substrate of a horizontal electric field LCD panel in accordance with the present invention;

FIG. 36 is a waveform diagram of a horizontal electric field LCD panel as depicted in FIG. 35;

FIG. 37 shows a circuit model of a TFT array substrate of a field-order driven horizontal electric field LCD panel that divides a display screen into upper and lower sections in accordance with the present invention;

FIG. 38 is a cross-sectional view of a basic unit pixel of a TFT array substrate of a MVA LCD panel in accordance with the present invention;

FIG. 39 is a cross-sectional view of a basic unit pixel of a TFT array substrate of a MVA LCD panel in accordance with the present invention;

FIG. 40 is a cross-sectional view of a basic unit pixel of a TFT array substrate of a MVA LCD panel in accordance with the present invention;

FIG. 41 is a cross-sectional view of a basic unit pixel of a TFT array substrate of a MVA LCD panel in accordance with the present invention;

FIG. 42 is a cross-sectional view of a manufacturing flow that adopts a halftone exposure method to form a contact pad for a pixel electrode in accordance with the present invention;

FIG. 43 is a cross-sectional view of a manufacturing flow that adopts a halftone exposure method to form a contact pad for a pixel electrode in accordance with the present invention;

FIG. 44 is a cross-sectional view of a manufacturing flow that adopts a halftone exposure method to give an island effect to a semiconductor layer of a thin film transistor component and form a contact hole in accordance with the present invention;

FIG. 45 is a cross-sectional view of a manufacturing flow that forms a source electrode, a drain electrode, a terminal electrode, and comb common electrode in accordance with the present invention;

FIG. 46 is a cross-sectional view of a flow of manufacturing a thin film transistor substrate by a halftone exposure method in accordance with the present invention;

FIG. 47A illustrates the structure of a horizontal electric field active matrix substrate at a center pixel common electrode of the center of a basic unit pixel;

FIG. 47B illustrates the structure of a horizontal electric field active matrix substrate showing a poor orientation area;

FIG. 48 illustrates a masking principle of a halftone exposure applied in the present invention;

FIG. 49 illustrates the principle of a halftone multiple exposure method applied in the present invention;

FIG. 50 is a cross-sectional view of a manufacturing flow of using a halftone exposure method to form a thin film transistor substrate in accordance with the present invention;

FIG. 51 is a cross-sectional view of a manufacturing flow of using a halftone exposure method to form a scan line portion, a pixel electrode and a terminal portion of a thin film transistor substrate in accordance with the present invention;

FIG. 52 shows a cross-sectional view of a manufacturing flow of using a halftone exposure method to give an island effect to a semiconductor layer of a thin film transistor component and expose a pixel electrode and a terminal portion completely;

FIG. 53 shows a cross-sectional view of a manufacturing flow before forming a source electrode and a drain electrode in the process of manufacturing a thin film transistor component as illustrated in FIGS. 52 and 53;

FIG. 54 is cross-sectional view of the structure forming a TFT array substrate of an orientation control electrode connected to a scan line and disposed on the previously formed pixel electrode;

FIG. 55 is a planar view of a TFT array substrate as depicted in FIG. 54;

FIG. 56 is a cross-sectional view of forming a vertical alignment cell of one type of orientation control electrode connected to a common electrode and disposed on the previously formed pixel electrode;

FIG. 57 is a cross-sectional view of a vertical alignment cell of one type of orientation control electrode connected to a pixel electrode and disposed on the previously formed plate electrode;

FIG. 58 is a cross-sectional view of a structure of forming only one type of orientation control electrode on a pixel electrode of the previously formed TFT array substrate;

FIG. 59 is a cross-sectional view of a structure of forming only one type of orientation control electrode on a pixel electrode of the previously formed TFT array substrate;

FIG. 60 is a cross-sectional view of a structure of forming only one type of orientation control electrode on a pixel electrode of the previously formed TFT array substrate;

FIG. 61 illustrates a manufacturing flow of performing the photolithographic procedure for three times that uses a MVA TFT array substrate to apply a halftone exposure method for two times;

FIG. 62 illustrates a manufacturing flow of performing the photolithographic procedure for three times that uses a MVA TFT array substrate to apply a halftone exposure method for two times;

FIG. 63 illustrates a manufacturing flow of performing the photolithographic procedure for three times that uses an IPS TFT array substrate to apply a halftone exposure method for three times; and

FIG. 64 illustrates a manufacturing flow of performing the photolithographic procedure for three times that uses an IPS TFT array substrate to apply a halftone exposure method for three times.

DETAILED DESCRIPTION OF THE PREFERRED EMBODIMENTS

To make it easier for our examiner to understand the objective, innovative features and performance of the present invention, we use a preferred embodiment and the accompanying drawings for a detailed description of the present invention.

Referring to FIGS. 1 and 2 for cross-sectional views of a current mainstream multi-domain vertical alignment liquid crystal display (MVA LCD) panel, a mechanism for controlling the direction of movements both is installed separately on upper and lower substrates to control the vertical alignment of anisotropic liquid crystal molecules of a negative dielectric constant. Because the discrimination line position in a pixel using this method is fixed without moving, uniform brightness is displayed in this LCD panel, and high quality LCD panels can be produced as a good yield rate. However, it is necessary to form a slit or a bump 2 disposed on a lateral side of a color filter (CF) substrate corresponding to a thin film transistor (TFT) substrate for the structure as shown in FIGS. 1 and 2 to control the liquid crystal alignment; thus, the production cost of the CF substrate is higher than that of the

twisted nematic (TN) CF substrate. To lower the cost of the CF substrate, all liquid crystal alignment control functions are built in the TFT substrate side.

Referring to FIGS. 54 to 60 for an embodiment of a CF substrate 74 side having no alignment control function as disclosed in the previous patents, these CF substrates 74 cannot be used as large substrates. These previous disclosures can be used for small pixels only. Because an edge field effect of a pixel electrode 5 is used, these substrates are not appropriate for the large pixel electrodes used for the liquid crystal TV.

With the two basic structures shown in FIGS. 3 and 4, a TFT substrate side has all of the liquid crystal alignment control functions. In the TFT substrate side shown in FIG. 3, two different liquid crystal alignment control electrodes 9, 10 are installed between the common electrode of the substrate and correspond to the pixel electrode 5 to successfully form an equal-potential distribution 11 as shown in FIG. 5. Alignment control electrode 10 of FIG. 4 is installed on a pixel electrode 5 at the TFT substrate side and between the slit for alignment control 6, and the pixel electrode 5 corresponds to a common electrode of the substrate to successfully form an equal-potential distribution 11 as shown in FIG. 6. Even for a structure as shown in FIG. 7, instead of the structure as shown in FIG. 6, the similar equal-potential distribution 11 can be formed successfully.

In FIGS. 5-7, a common electrode is located facing to the liquid crystal alignment control electrode 9. The closer the distance from the common electrode to the liquid crystal alignment control electrode 9, the more similar the equal potential distribution diagram 11 of FIGS. 5-7 will be. This is because the liquid crystal alignment control electrode 9 of FIG. 5 is not connected to the pixel electrode 5 which is connected to the common electrode. Also disclosed in FIG. 7, an orientation control electrode 12 disposed under the orientation control slit of the pixel electrode.

If a cell gap is greater than 5 μm , the structure of a pixel electrode 5 of a TFT substrate connected to the liquid crystal alignment control electrode 10 in accordance with the present invention almost has no effect. However, if the cell gap is below 3 μm , the effect is significant. If the cell gap is below 2.5 μm , a sufficiently equal-potential distribution diagram 11 is formed for controlling the alignment of liquid crystal molecules.

Referring to FIGS. 15 and 17 for planar views of Embodiment 1 of a TFT substrate, two types of different alignment control electrodes 9, 10 are formed at an upper layer of a pixel electrode 5, and an alignment control electrode installed at the middle of a pixel is coupled to a gate electrode 13 and installed parallel with a common electrode 16. Another alignment control electrode with a different alignment control is passed and disposed at a contact pad 35 in the pixel electrode 5 and coupled to the pixel electrode 5. Referring to FIGS. 38 and 40 for a cross-sectional view of Embodiment 1 of the present invention, the height of alignment control electrode 10 of the pixel electrode 5 is increased to get closer to the common electrode 16 of the substrate as much as possible.

Referring to FIGS. 8, 9, 11, 13, 15, and 17, wherein FIG. 10 is a cross-sectional view of a MVA LCD panel adopting a TFT matrix substrate, FIG. 9 is a cross-sectional view of TFT array substrate used for a MVA LCD panel, and FIGS. 11 and 13, which are the partial cross-sectional view of the TFT array substrate used in the MVA LCD panel shown in FIGS. 15 and 17, respectively, in which the pixel electrode 5 must be installed at a lower layer to form a liquid crystal alignment control electrode at an upper layer of the pixel electrode 5 in accordance with the present invention. Therefore, its charac-

teristic resides on the fact that the photolithographic procedure is used for producing a pixel electrode **5**. FIG. **8** shows a process of using the photolithographic procedure for three times as depicted in FIG. **61**. To shorten the manufacturing process, the present invention adopts a halftone exposure method, characterized in that an exposure method as shown in FIGS. **48** and **49** is used for producing two or more types of photoresist thicknesses **53**, **54** after the image is developed.

FIGS. **8-12** also disclose a contact pad **22** disposed in the pixel electrode **5** for connection with the orientation control electrode **10**, and a substrate **25**; FIGS. **10** and **12** further show a contact pad **23** disposed in the pixel electrode **5** for connection with an electrode **24**; FIGS. **13** and **14** show a pad electrode **31**; FIGS. **15-18** show a thin film transistor **32**, a contact hole **33** coupled to orientation control electrode **9** and common electrode **16**, a contact hole **35** coupled to orientation control electrode **10** and contact pad disposed in the pixel electrode **5**; FIG. **18** shows a contact hole **36** proximate the drain electrode **18**; and FIGS. **19** and **20** shows a thin film transistor **37** for driving pixel electrodes **40** disposed in a large panel area and a thin film transistor **38** for driving pixel electrodes **41** disposed in a small panel area.

In the first of the three times of photolithographic procedure as shown in FIG. **61**, a gate electrode **13**, a pixel electrode **5**, a common electrode **16** and a contact pad **14** in a pixel electrode **5** are formed. In the first procedure, two manufacturing processes exist as shown in FIGS. **42** and **43**, and either one of the two manufacturing processes can be used for forming the pixel electrode **5**, but it is preferable to select a shorter process as shown in FIG. **42**. If the thickness of the alignment control electrode as shown in FIG. **9** is reduced, and the halftone exposure method is used in the third time photolithographic procedure, it is preferable to select the process as shown in FIG. **43**.

An aluminum alloy is used for making a scan line **13** (or a gate electrode) in this invention; therefore, ITO (Indium Tin Oxide) cannot be used in the pixel electrode **5** because a partial battery reaction will result, and the abnormal corrosion or ITO blackening issues usually occur. As a result, the pixel electrode **5** is generally a transparent electrode made of a thin film oxide such as titanium nitride or zirconium nitride.

The nitride of the transparent pixel electrode and the P—SiNx of the gate insulating film **8** cannot have a large selectivity for creating a contact hole **34** by a dry etching method, and the manufacturing processes of the previous embodiments as shown in FIGS. **51** to **53** cannot be used anymore. To solve this problem, the present invention uses an aluminum alloy series contact pad to solve the aforementioned problem.

In the second time of the photolithographic procedure, the thin film semiconductor components are separated and the contact hole **34** is formed. This procedure is illustrated in FIG. **44**. Because this procedure also adopts the halftone exposure method, the procedure of the first time can be used for performing two operations. The process adopted in FIGS. **11** and **17** is a halftone exposure process other than that adopted in FIG. **61**, and the halftone exposure method as illustrated in FIG. **46** is used for separating the thin film semiconductor components while forming a source electrode **17** and a drain electrode **18**. The halftone exposure process as shown in FIG. **46** is very similar to the halftone exposure process as shown in FIG. **50**, but the halftone exposure process as shown in FIG. **46** is more difficult to take place. When a positive photoresist layer at a thin area **54** is removed by an oxygen plasma method in the foregoing embodiment, as shown in FIG. **50**, sidewalls of a thin film semiconductor layer **21** are oxidized, and the oxidization takes place easily at the time of removing

an ohmic contact layer **20** (n+a—silicon layer) of a channel portion of the thin film transistor component, but an even removal cannot be achieved. In the situation, as shown in FIG. **46**, the thin film semiconductor layer **21** is protected by a metal barrier **19** layer completely when the positive photoresist layer at the thin area **54** is removed by the oxygen plasma method, and thus the oxidization almost will not take place at the sidewalls.

FIGS. **42** and **43** also show a transparent electrode layer **55**, a low resistance electrode layer **56** for wiring, and a residual photoresist **57** after oxygen plasma ashing; FIG. **44** shows a mask **58** for halftone exposure in an area without rays, a mask **59** for halftone exposure for an area with rays, a mask **60** for halftone exposure in an area with half-transparent rays; a photoresist for halftone exposure **61**, and a connection terminal portion **62** for external circuit; FIG. **47B** shows an area **63** with fine rubbing procedure of the orientation film, an area **64** with worse rubbing procedure of the orientation film, and a fiber **65** for rubbing procedure; and FIGS. **48** and **49** show a glass **66** for shielding, a ray **67** in a complete exposure area, a ray **68** in a non-complete exposure area.

In the third photolithographic procedure as shown in FIG. **61**, an exposure method is generally used for forming a source electrode **17**, a drain electrode **18** and an alignment control electrode as shown in FIG. **8**. In FIG. **9**, the third photolithographic procedure also adopts a photolithographic procedure that uses a halftone exposure method as shown in FIG. **45**.

In FIGS. **8**, **9** and **13**, the third photolithographic procedure is used for forming two different types of alignment control electrodes **9**, **10** at an upper layer of the pixel electrode **5** through the insulating film **8**. In FIG. **11**, a fourth photolithographic procedure is used for forming two different types of alignment control electrodes **9**, **10**, such that an oblique direction of vertical alignment negative dielectric constant anisotropic liquid crystal molecules **7**, as shown in FIGS. **3** and **5**.

In FIGS. **8**, **9** and **13**, a passivation film **15** is a P—SiNx film formed partially by using a CVD method. An ink jet printing method or a plate offset printing method is used to coat a passivation film **15** made of an organic compound such as BCB. The shortcoming of the process shown in FIG. **11** resides on that a short circuit may occur easily at the common electrode **16** of the corresponding substrate when two different types of alignment control electrodes **9**, **10** are formed on the passivation film **15**.

Referring to FIGS. **16** and **18** for planar views of Embodiment 2 of TFT substrate in accordance with the present invention, a slit **6** is formed on the pixel electrode **5** for the alignment control, and a liquid crystal alignment control electrode **10** connected to the pixel electrode **5** is formed at an upper layer of the pixel electrode **5** through the insulating film **8**. Referring to FIGS. **39** and **41** for cross-sectional views of Embodiment 2 of a pixel, Embodiment 2 similar to Embodiment 1 also installs the alignment control electrode **10** connected to the pixel electrode **5** at a position proximate to the substrate, and thus its characteristic resides on that each type of electrodes and semiconductor layers is installed at a lower layer of the alignment control electrode **10**.

Embodiments 1 and 2 of the present invention include all alignment control functions at the TFT substrate side. Comparing Embodiment 1 with the previous methods as shown in FIGS. **1** and **2**, the methods adopted by the present invention, as shown in FIGS. **3** and **4**, also have the existing short-circuit problem at the same layer of a video signal line **17** while the alignment control electrode is being formed. Therefore, the pixel structures as shown in FIGS. **15** and **17** are avoided, and a structure having a curvature of 90 degrees at the center of the pixel is used instead. The video signal line **17** and the align-

ment control electrode of this structure are equidistantly arranged in parallel with each other, so as to reduce the chance of having a short circuit.

Referring to FIGS. 10, 12, 14, 16, and 18, wherein FIG. 10 is a cross-sectional view of a TFT array substrate used for a MVA LCD panel, and FIGS. 12 and 14 that are partial cross-section views of the TFT portions as shown in FIGS. 16 and 18 respectively, the basic principle of the Embodiment 2 as illustrated in FIGS. 4 and 6 adopts an alignment control slit 6 for determining the oblique direction of the liquid crystal molecules correctly; however, Embodiment [1] 2 cannot increase the strength of electric field as Embodiment 1 does. Therefore, the response rate of Embodiment 2 is slower than that of Embodiment 1. In the application of displaying animations, it is appropriate to adopt Embodiment 1 for the manufacture of LCD panels. From the planar views, as shown in FIGS. 15 and 17, many metal wires are installed densely on the same layer in Embodiment 1, and thus the existing short circuit problem may occur easily. In addition to the short-circuit issue, the voltage applied to the pixel electrode 5 of Embodiments 1 and 2 is not 100% applied to the liquid crystal layer, and thus the shortcoming of requiring a higher driving voltage as shown in FIGS. 1 and 2 still exists. Because the CF substrate 74 can use a low-cost CF substrate 74 which has about the same cost of TN, the product competitiveness can be improved. Particularly, the present invention provides a driving method of a field order driven the LCD panel that does not require a color filter as shown in FIGS. 3 and 4. Unlike the conventional method shown in FIGS. 1 and 2, the MVA LCD panel has to be aligned to the upper and lower substrates before the MVA LCD panel can be driven by the field order. In other words, the MVA LCD panel driven by the field order of the present invention does not require to be aligned with the upper substrate or the lower substrate. Referring to FIGS. 19 and 21 for planar views of the TFT substrate in accordance with Embodiment 3 of the present invention and FIG. 23 for a circuit model of the TFT substrate of the invention, a basic unit pixel is divided by the video signal line 17 into two sub pixels: sub pixel A and sub pixel B. The ratio of areas of the sub pixel A to the sub pixel B is approximately equal to 1:2. Even though the data is obtained from the same video signal line 17, the phase is changed by different common electrode, since each pixel electrode 40, 41 is combined with a capacitor of a different common electrode, and a horizontal period (H period) is applied, and the waveform of a signal with an opposite polarity maintains the effective voltage of the sub pixel A greater than the effective voltage of the sub pixel B. FIG. 24 shows the quantity of light transmission of the LCD panel when the signal waveform is driven, and the threshold voltage of the liquid crystals of the sub pixel A and the sub pixel B can be changed for correcting γ .

FIG. 62 shows the process of manufacturing the TFT substrates as illustrated in FIGS. 19 and 21. A common electrode 39 is manufactured in the first the photolithographic procedure. In Embodiment 3, as shown in FIG. 23, it is not necessary to arrange the video signal line 17 in parallel with the common electrode 39, and thus the common electrode 39 is manufactured by the third photolithographic procedure as shown in FIG. 62.

FIG. 53 shows a residual photosist after general exposure 72; FIG. 54 shows an embodiment of a CF substrate 74; FIG. 55 shows a source electrode 73 formed from an orientation control electrode 75 coupled to the gate electrode 13; FIGS. 56 and 57 shows an orientation control electrode 76 and common electrode 16 formed on the passivation film 15; and FIG. 59 shows a metal electrode 77 proximate the substrate 25, an orientation control electrode 78 made from transparent

electrode material as the pixel electrode, and an electrode 79 proximate the orientation control electrode 78.

FIG. 25 shows a circuit model of the TFT substrate when a high-precision super large LCD panel is manufactured. FIGS. 26 to 29 show the method of driving a TFT substrate, as illustrated in FIG. 25. FIGS. 26 to 29 relate to the field order driving method. Because the display screen is divided into two: an upper screen and a lower screen, the video signal line 17 is also divided into two: an upper video signal line 51 and a lower video signal line 52, and the video signals 51, 52 of the same polarity are applied.

The common electrode 39 has not been divided into two, but both upper and lower portions integrated. FIGS. 26 and 28 show that video signals 51, 52 are written from the center of the screen to the upper and lower screens in order to prevent the blocks of the upper and lower screens from being separated. FIGS. 27 and 29 show that video signals 51, 52 are written from the upper and lower screens to the center of the screens. To divide the display screen into two, the horizontal scan period is extended to two times of 2H. FIGS. 26 and 27 show that the horizontal scan period is divided into two, such that different video signals can be written for two pixels by two different multitasking methods. FIGS. 28 and 29 show that the horizontal scan period is divided into three, such that different video signals 51, 52 can be written for three pixels by three multitasking methods.

Referring to FIGS. 31 and 34 for a planar view and a cross-sectional view of an IPS TFT substrate in accordance with Embodiment 4 of the present invention, and FIG. 63 for the manufacturing process of an IPS TFT substrate in accordance with Embodiment 4 of the present invention, three times of photolithographic procedure adopting three times of halftone exposure method are conducted. FIG. 32 shows a circuit model of a TFT substrate as illustrated in FIG. 34. The center of a pixel and the video signal 17 are arranged in parallel with the common electrode 46. FIG. 37 shows a circuit model of a TFT substrate when a high-precision super large LCD panel is manufactured. FIG. 36 shows a driving waveform diagram of a TFT substrate as illustrated in FIG. 37. Signal waveforms of different polarities are applied on even-numbered rows and odd-numbered rows, and signal waveforms of different polarities are applied to the even-numbered rows and odd-numbered row of video signal waveforms, and a signal with an opposite polarity is applied to the common electrode 46 of each corresponding video signal line 51, 52.

Even the modes of liquid crystals are different, the circuit models of the common electrode 46 and the video signal line 51, 52 is identical to those as shown in FIG. 25. The IPS TFT substrate as shown in FIG. 37 can also adopt the same field order driving method of Embodiment 3. Similar to the process as shown in FIG. 25, the process as shown in FIG. 37 divides the display screen into two: an upper screen and a lower screen, and thus the video signal line 17 is also divided into two: an upper video signal line 51 and a lower video signal line 52, and the polarity of video signals are the same.

The common electrode 46 has not been divided into two, but it is connected from top to bottom as a whole. To prevent the blocks of upper and lower screens from being separated, the video signals 51, 52 are written from the center of the screen upward or downward, or the video signals 51, 52 are written from the top or bottom of the screen towards the center of the screen. The driving method for the scan lines 13 is identical to that of Embodiment 3.

Referring to FIGS. 30 and 35 for a planar view and a cross-sectional view of a FFS TFT substrate in accordance with Embodiment 5 of the present invention respectively,

FIG. 33 for a cross-sectional view of a portion of a thin film transistor, and FIG. 64 for the manufacturing process of a FFS TFT substrate in accordance with Embodiment 5 of the present invention, the photolithographic procedure is conducted for three times, and a halftone exposure method is applied for all of the three times. The three times of photolithographic procedure in Embodiments 4 and 3 use the halftone exposure method as shown in FIG. 47A. Unlike the vertical alignment LCD panel, a horizontal electric field panel requires a different alignment processing procedure (such as the friction processing). To prevent having a poor alignment area, it is necessary to minimize the roughness of the TFT substrate. However, the planar views of FIGS. 34 and 35 show that the thickness of electrodes 44, 45 is increased to lower the resistance of a common electrode 46 at the center of the screen.

Because a poor alignment area, as shown in FIG. 47B, must occur in both IPS and FFS modes, the shortcoming of being unable to show the black color for a black potential exists. To minimize the poor alignment area, it is necessary to apply the halftone exposure method for three times.

FIGS. 42 and 43 use the manufacturing process as illustrated in FIG. 64, and the process of the halftone exposure method is applied for one time, and any one can be selected. FIG. 44 illustrates the process of applying the halftone exposure method for the second time, FIG. 45 illustrates the process of applying the halftone exposure method for three times, and FIG. 46 illustrates the process of performing the photolithographic procedure for four times for manufacturing the FFS TFT substrate. The halftone exposure method is applied for two times.

Even if the FFS TFT substrate as shown in FIG. 35 adopts the same driving method as the IPS TFT substrate as shown in FIG. 34, all circuit models of the TFT substrate as shown in FIG. 37 can be applicable for the FFS mode of FIG. 35. If the driving method of FIG. 36 is used, the FFS mode with a high

driving voltage can be driven easily. Because the FFS mode can produce a strong electric field, the response rate of the liquid crystal molecules is smaller than that of the IPS mode and applicable for the field order driving method. Particularly, a high voltage can be applied to the LCD panels as shown in FIGS. 36 and 37, and thus such method is considered as a driving method applicable for high-speed operations, and most suitable for the field order driving method for the divided upper and lower screens as shown in FIGS. 26 to 29.

What is claimed is:

1. A method of fabricating MVA active matrix substrate, and said substrate constituting an active matrix display device, characterized in that: three photolithographic steps are performed in the fabrication process:

- (1) a step of forming a gate electrode, a pixel electrode and a contact pad in said pixel electrode via photolithography using a halftone exposure method, wherein the halftone exposure method is used for the first time in the fabrication process;
- (2) a step of forming a separate thin film semiconductor layer component, and a contact hole via photolithography using the halftone exposure method, wherein the halftone exposure method is used for the second time in the fabrication process;
- (3) a step of forming a source electrode, a drain electrode, an orientation control electrode and a common electrode via photolithography using a general exposure method such that after an ohmic contact layer of a channel portion of said thin film transistor is dry etched, a partial film of a passivation layer is formed by a silicon nitride film by using a mask deposition method wherein said film is formed at a terminal portion other than those of a gate electrode, a source electrode and a common electrode.

* * * * *

专利名称(译)	制造多域垂直配向 (MVA) 液晶显示器的方法		
公开(公告)号	US8194227	公开(公告)日	2012-06-05
申请号	US12/558086	申请日	2009-09-11
申请(专利权)人(译)	MIKUNI ELECTRON CO.LTD.		
当前申请(专利权)人(译)	知识产权DISCOVERY CO. , LTD.		
[标]发明人	TANAKA SAKAE TOSHIYUKI SAMEJIMA		
发明人	TANAKA, SAKAE TOSHIYUKI, SAMEJIMA		
IPC分类号	G02F1/136 G02F1/1337 G02F1/13		
CPC分类号	G02F1/133707 G02F1/134363 G09G3/3648 G02F2001/134372 G02F2001/136231 G09G2310/0283 G02F2001/13712 G09G2310/0218 G02F2001/136236		
审查员(译)	ROBINSON , MARK		
优先权	2006202563 2006-06-15 JP		
其他公开文献	US20100066931A1		
外部链接	Espacenet USPTO		

摘要(译)

本发明公开了一种超大型广角高速响应液晶显示装置，采用光刻工艺制作三次。本发明采用半色调曝光技术形成栅极，公共电极，像素电极和接触垫，然后采用半色调曝光技术形成硅 (Si) 岛和接触孔，以及一般的曝光技术形成源电极，漏电极和取向控制电极。钝化层使用掩模沉积方法。通过使用P-CVD法形成膜，或者通过使用油墨涂覆方法或喷涂方法在局部区域形成保护区域，以及用于超大角度广角高速响应液体的 TFT阵列基板可以制造通过使用光刻程序制造三次的晶体显示装置。

MVA Mode Using a Photolithographic Procedure for Three Times (B)

- (1) Form a gate electrode, a pixel electrode and a contact pad in the pixel electrode (wherein the photolithographic procedure uses a halftone exposure method for the first time).
- (2) Form a separate thin film semiconductor layer component, and a contact hole (wherein the photolithographic procedure uses a halftone exposure method for the second time).
- (3) Form a source electrode, a drain electrode, an orientation control electrode and a common electrode (wherein the photolithographic procedure uses a general exposure method).

After an ohmic contact layer of a channel portion of the thin film transistor is dry etched, a partial film of a passivation layer is formed by a silicon nitride film by using a mask deposition method (wherein the film is formed at a terminal portion other than those of a gate electrode, a source electrode and a common electrode).