



US007656480B2

(12) **United States Patent**
Hirai et al.

(10) **Patent No.:** **US 7,656,480 B2**
(45) **Date of Patent:** **Feb. 2, 2010**

(54) **PHASE DELAY ELEMENT FOR TRANSMISSIVE AND REFLECTIVE TYPE LIQUID CRYSTAL DISPLAY**

2005/0122453 A1* 6/2005 Jang et al. 349/114
2007/0019138 A1* 1/2007 Kubo et al. 349/114
2008/0198306 A1* 8/2008 Shibazaki 349/114

(75) Inventors: **Akira Hirai**, Seongnam-si (KR);
Jin-Hyuk Yun, Seoul (KR); **Kee-Han Uh**, Yongin-si (KR); **Min-Soo Park**, Yongin-si (KR)

FOREIGN PATENT DOCUMENTS

CN 1342191 3/2002
CN 1391129 1/2003
CN 1438529 8/2003
JP 2003140152 5/2003

(73) Assignee: **Samsung Electronics Co., Ltd.** (KR)

OTHER PUBLICATIONS

(*) Notice: Subject to any disclaimer, the term of this patent is extended or adjusted under 35 U.S.C. 154(b) by 377 days.

European Search Report; Application No. 05015191.9-2205; Date Jan. 13, 2006.

European Office Action; 05015191.9—2005; Jul. 24, 2007. All references cited in the foreign Office action and not previously submitted are listed above.

* cited by examiner

(21) Appl. No.: **11/184,436**

Primary Examiner—James A Dudek

(22) Filed: **Jul. 19, 2005**

(74) *Attorney, Agent, or Firm*—Cantor Colburn LLP

(65) **Prior Publication Data**

US 2006/0012737 A1 Jan. 19, 2006

(57) **ABSTRACT**

(30) **Foreign Application Priority Data**

Jul. 19, 2004 (KR) 10-2004-0055827

A phase delay element includes a brightness enhancement layer intermediate a reflection layer and an artificial light. The brightness enhancement layer is defined by a first surface and an opposite second surface. The first surface faces the reflection layer. A first light from the artificial light is incident on the second surface. A phase of the first light is delayed by about 1/4 phase ($\lambda/4$) so that a second light is emitted from the first surface toward the reflection layer. The second light is reflected from the reflection layer so that a third light is emitted from the reflection layer toward the first surface. A phase of the third light is delayed by about 1/4 phase ($\lambda/4$) so that a fourth light is emitted from the second surface. Therefore, a portion of the artificial light, which is reflected from the reflection layer, is recycled to improve a luminance of an LCD apparatus.

(51) **Int. Cl.**
G02F 1/1335 (2006.01)

(52) **U.S. Cl.** **349/114**

(58) **Field of Classification Search** 349/114
See application file for complete search history.

(56) **References Cited**

U.S. PATENT DOCUMENTS

6,909,486 B2* 6/2005 Wang et al. 349/137
7,113,238 B2* 9/2006 Okumura 349/114
2001/0020990 A1 9/2001 Moon
2004/0105059 A1 6/2004 Ohyama et al.
2004/0189904 A1* 9/2004 Kang et al. 349/114

19 Claims, 22 Drawing Sheets

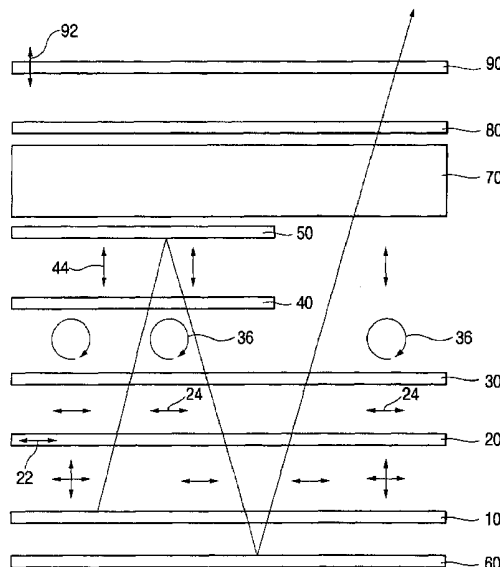

FIG. 1

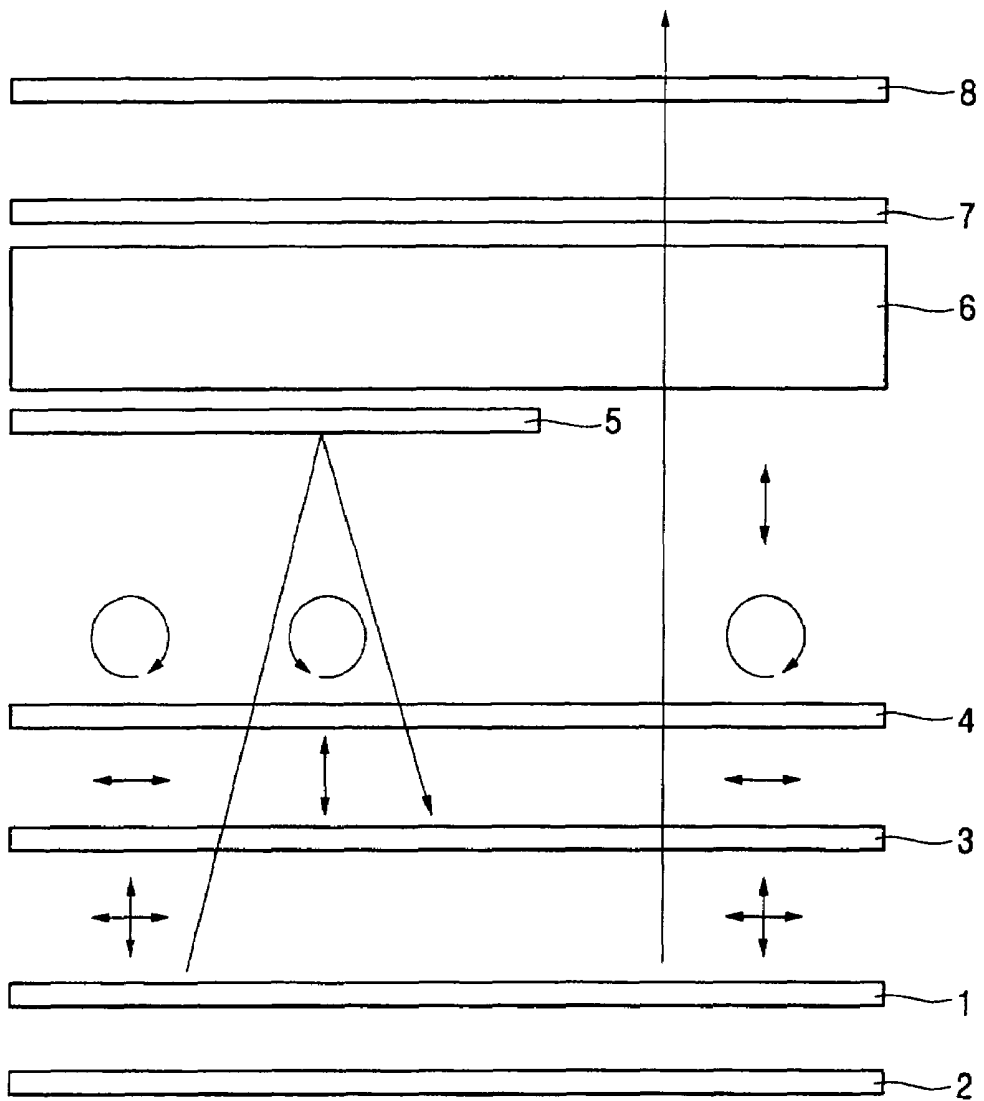

FIG. 2

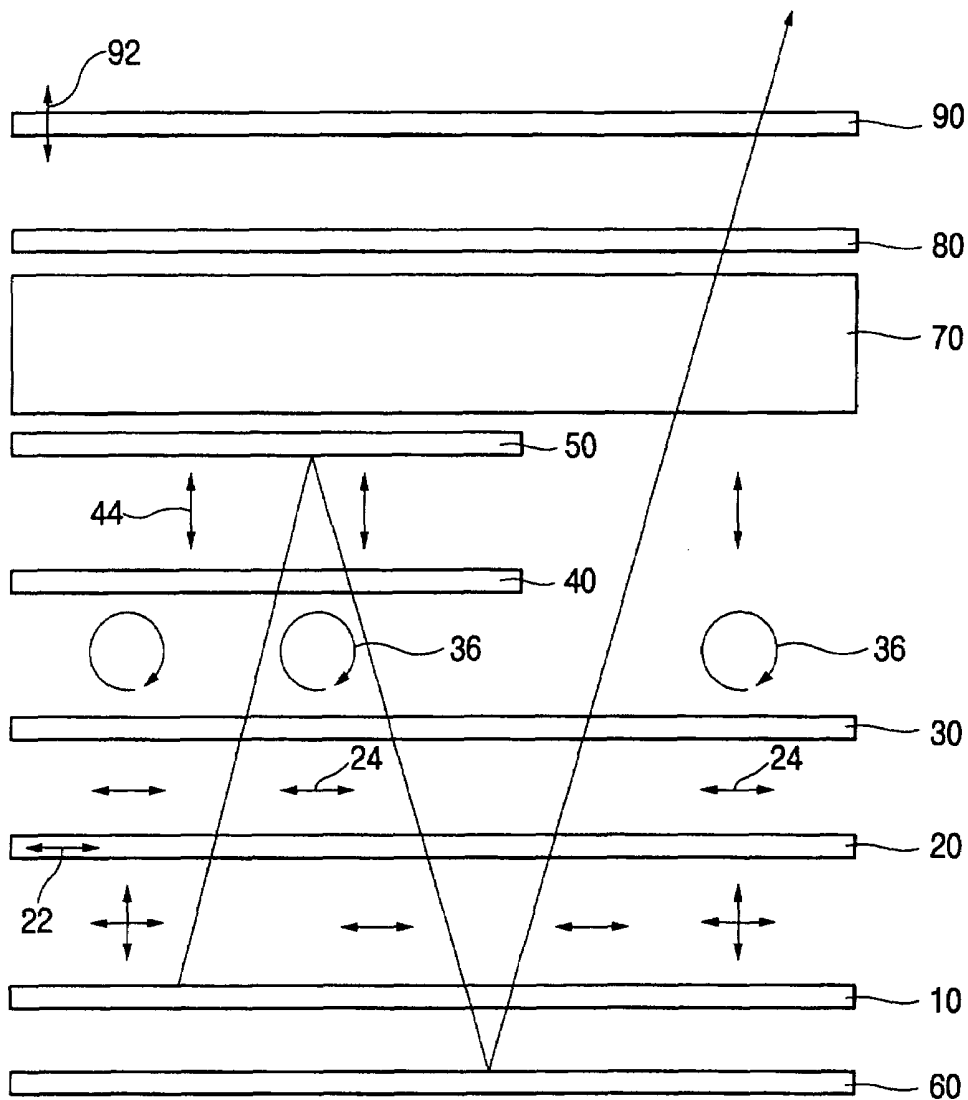

FIG. 3

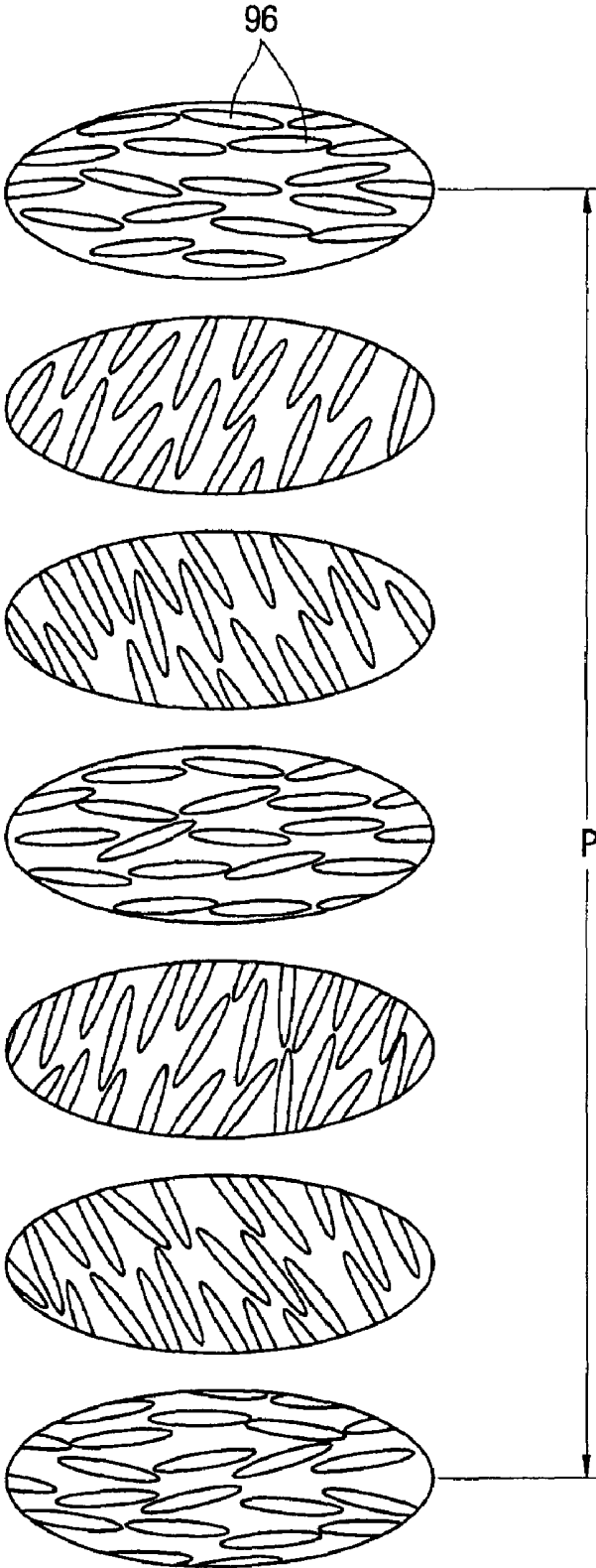

FIG. 4A

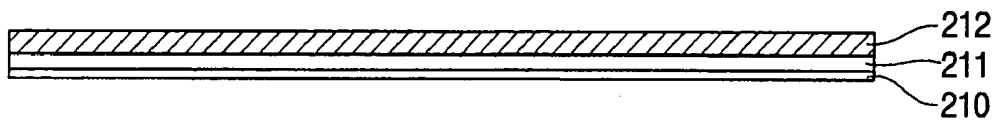

FIG. 4B

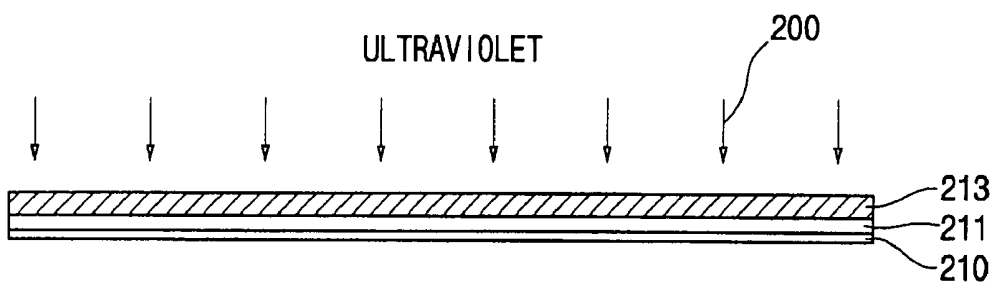

FIG. 4C

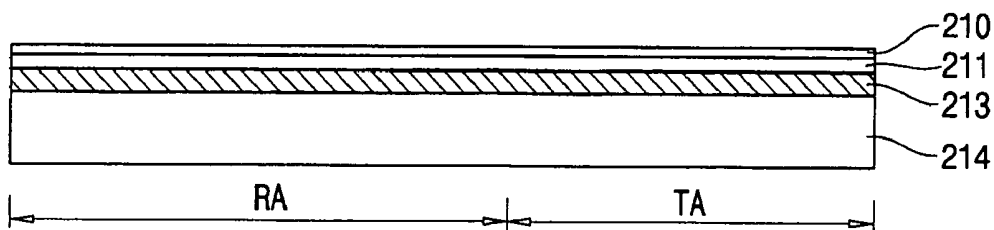

FIG. 4D

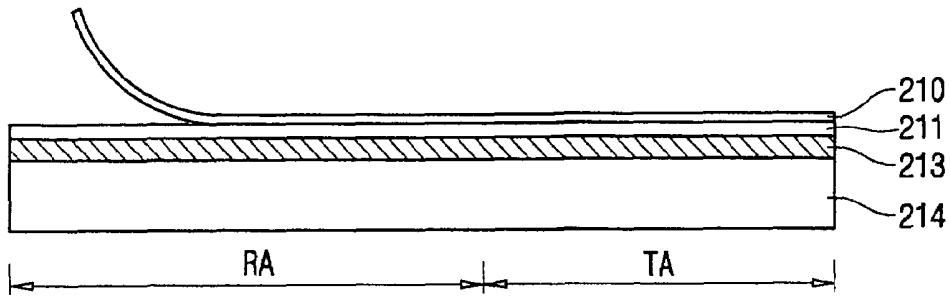

FIG. 4E

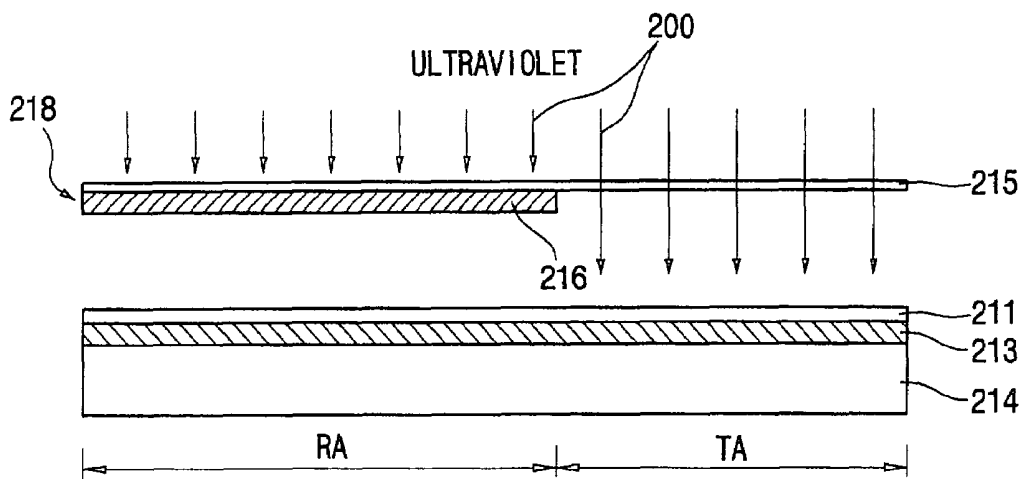

FIG. 4F

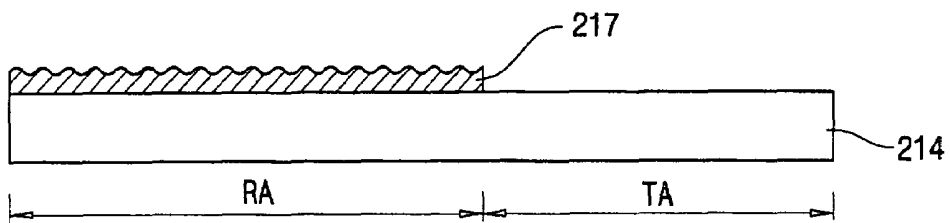

FIG. 5A

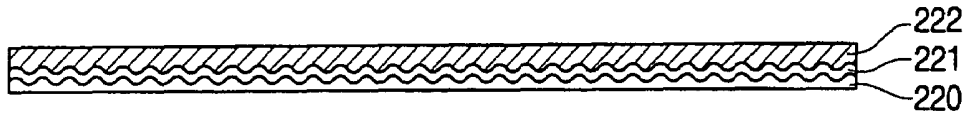

FIG. 5B

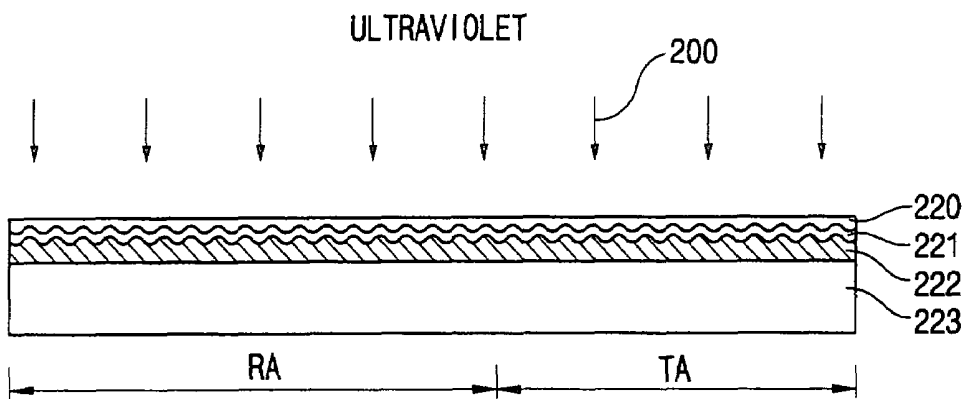

FIG. 5C

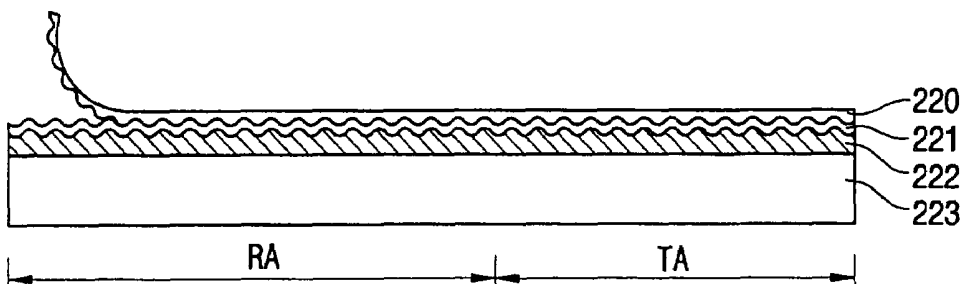

FIG. 5D

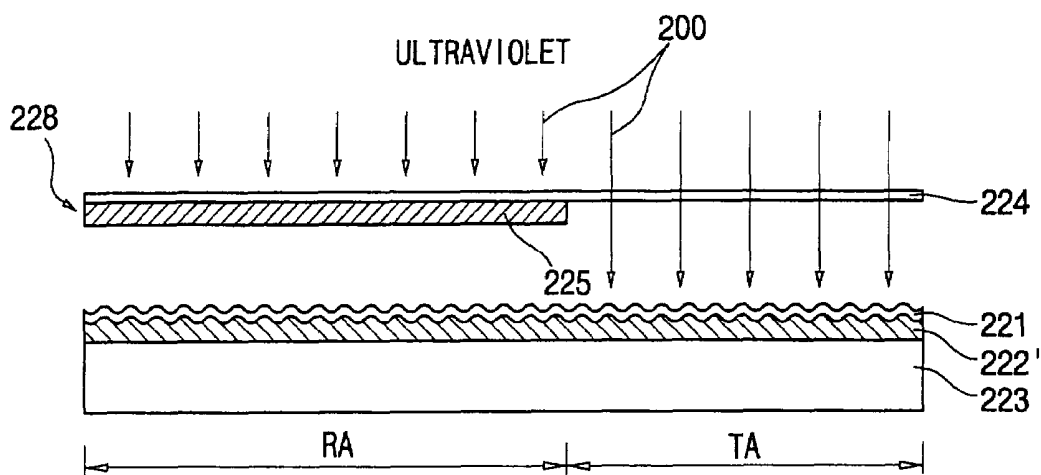

FIG. 5E

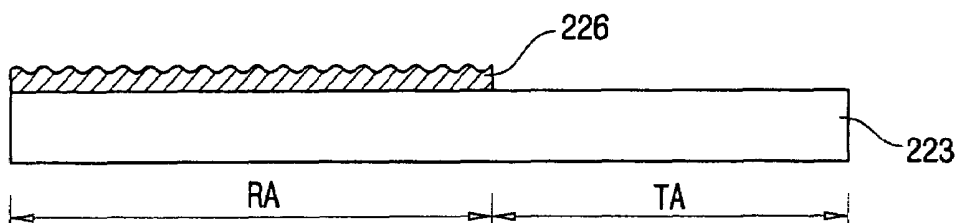

FIG. 6A

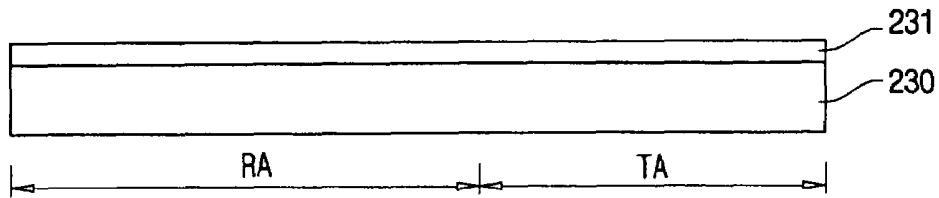

FIG. 6B

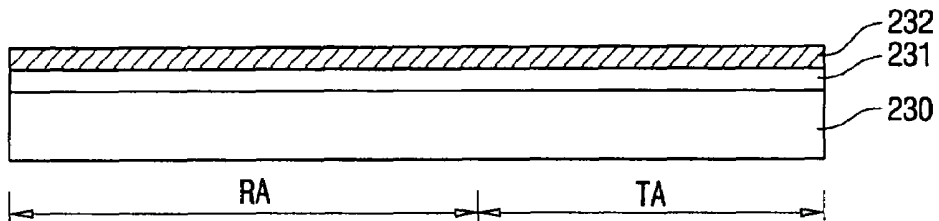

FIG. 6C

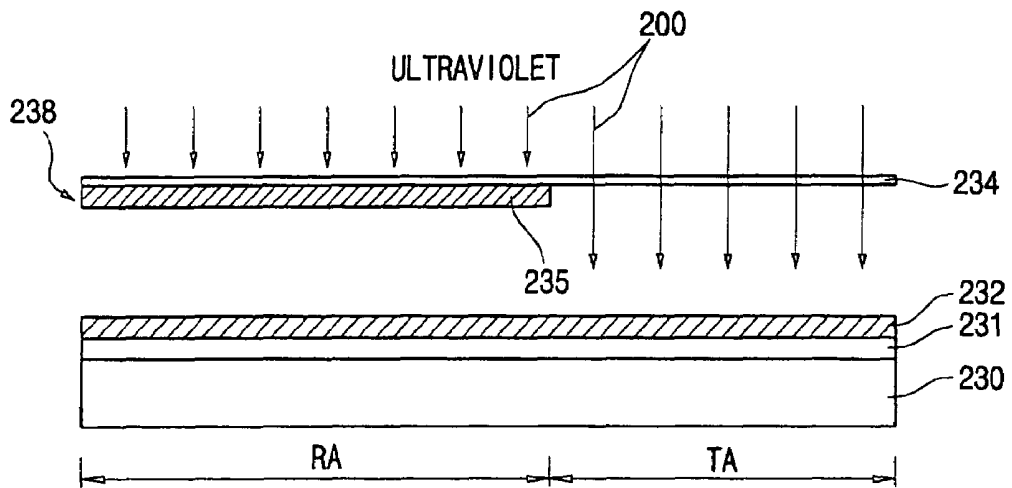

FIG. 6D

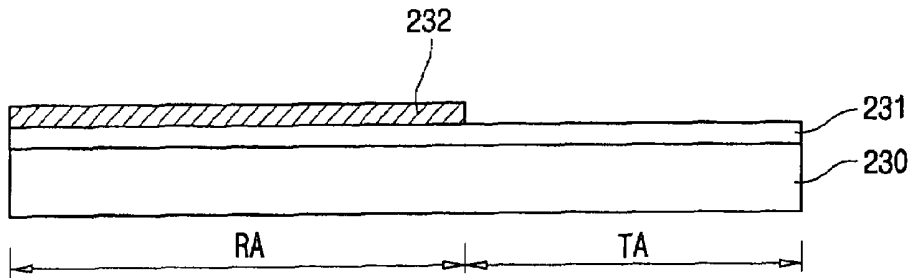

FIG. 6E

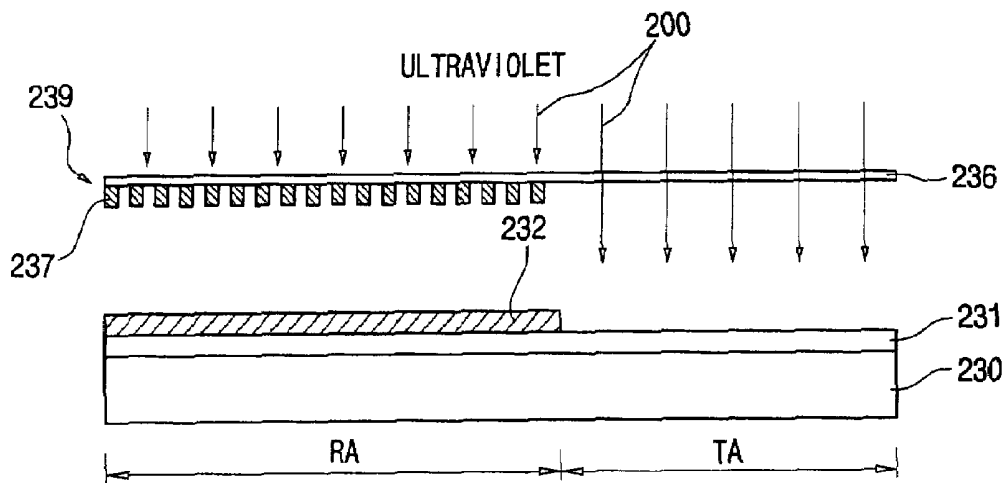

FIG. 6F

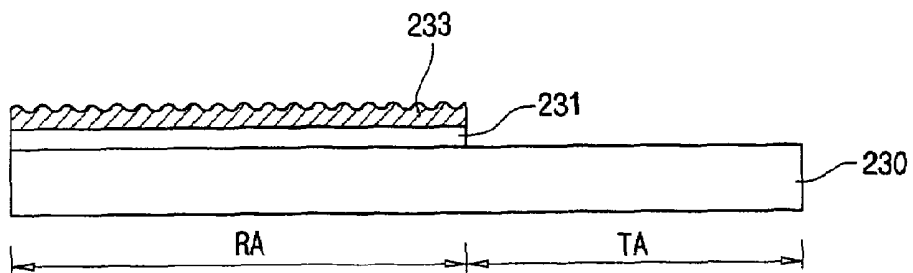

FIG. 7A

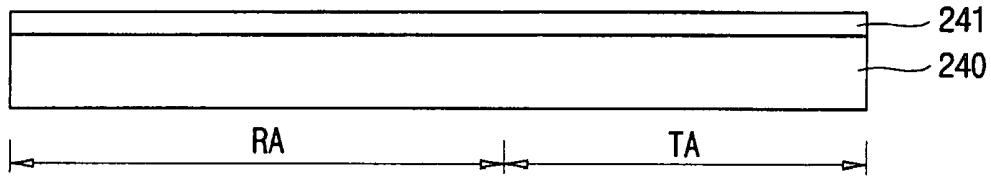

FIG. 7B

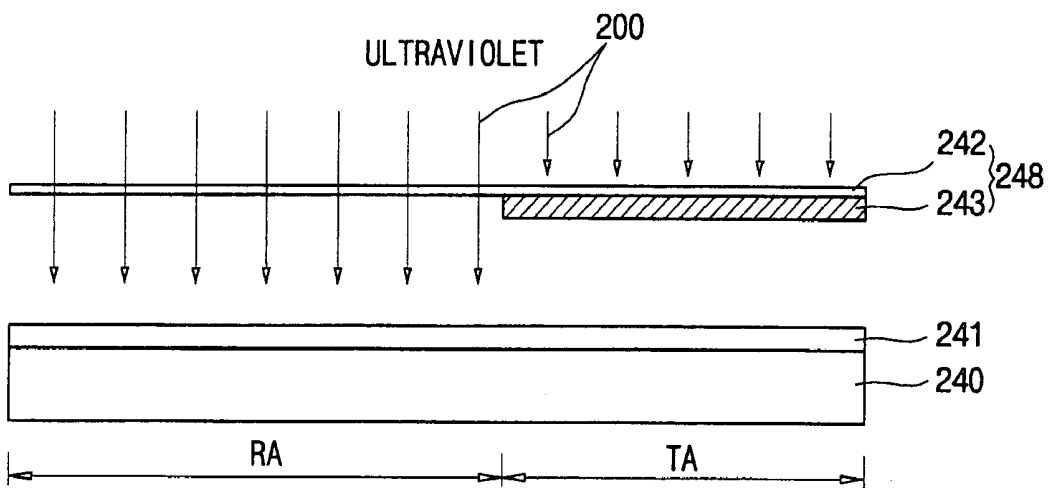

FIG. 7C

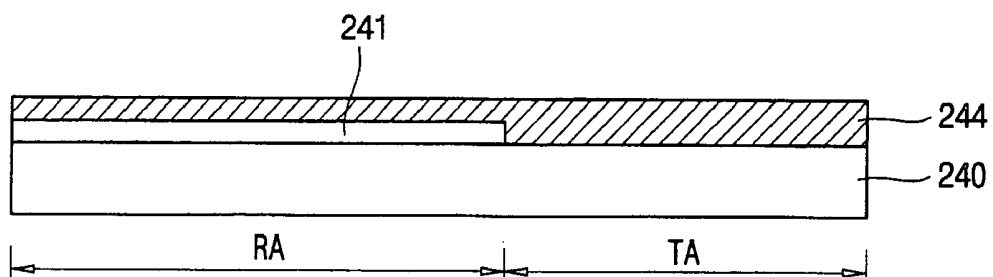

FIG. 7D

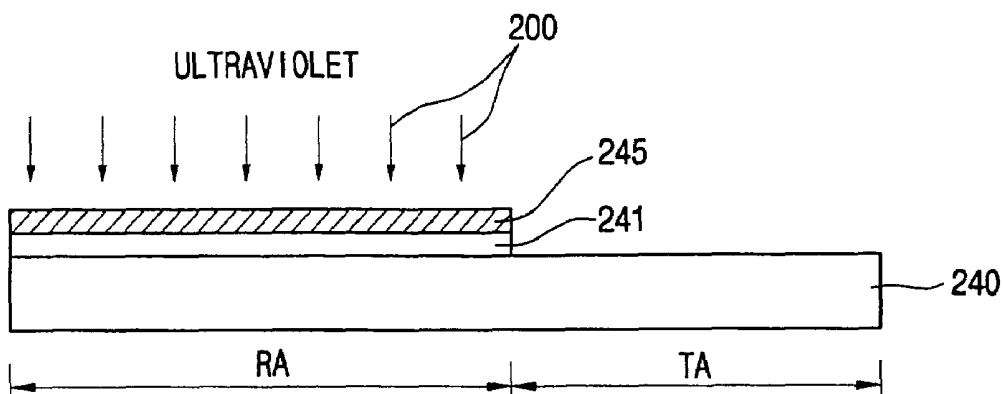

FIG. 7E

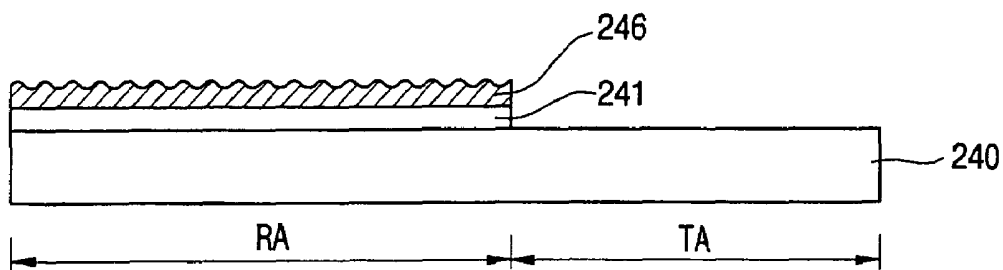

FIG. 8

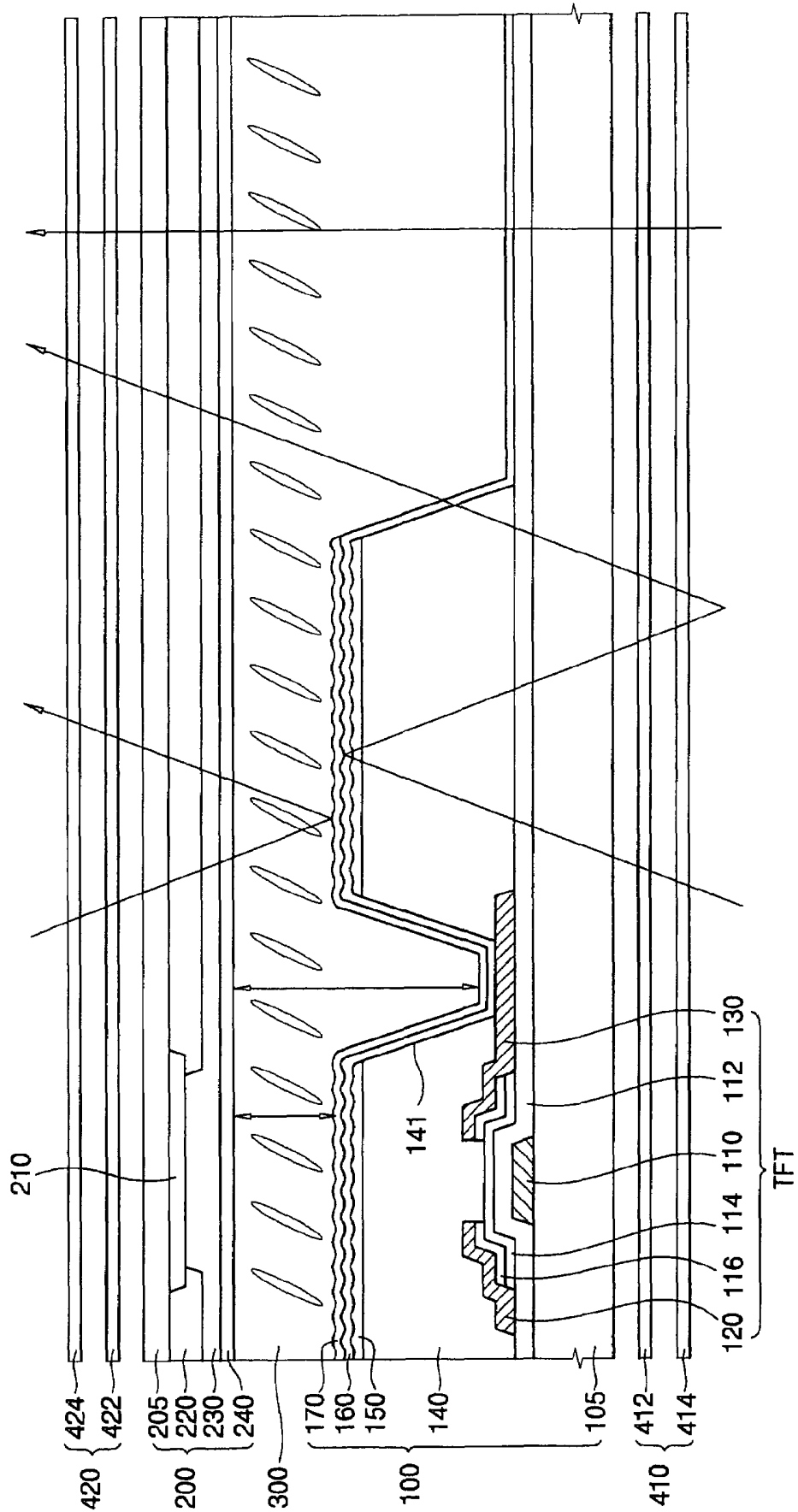

FIG. 9B

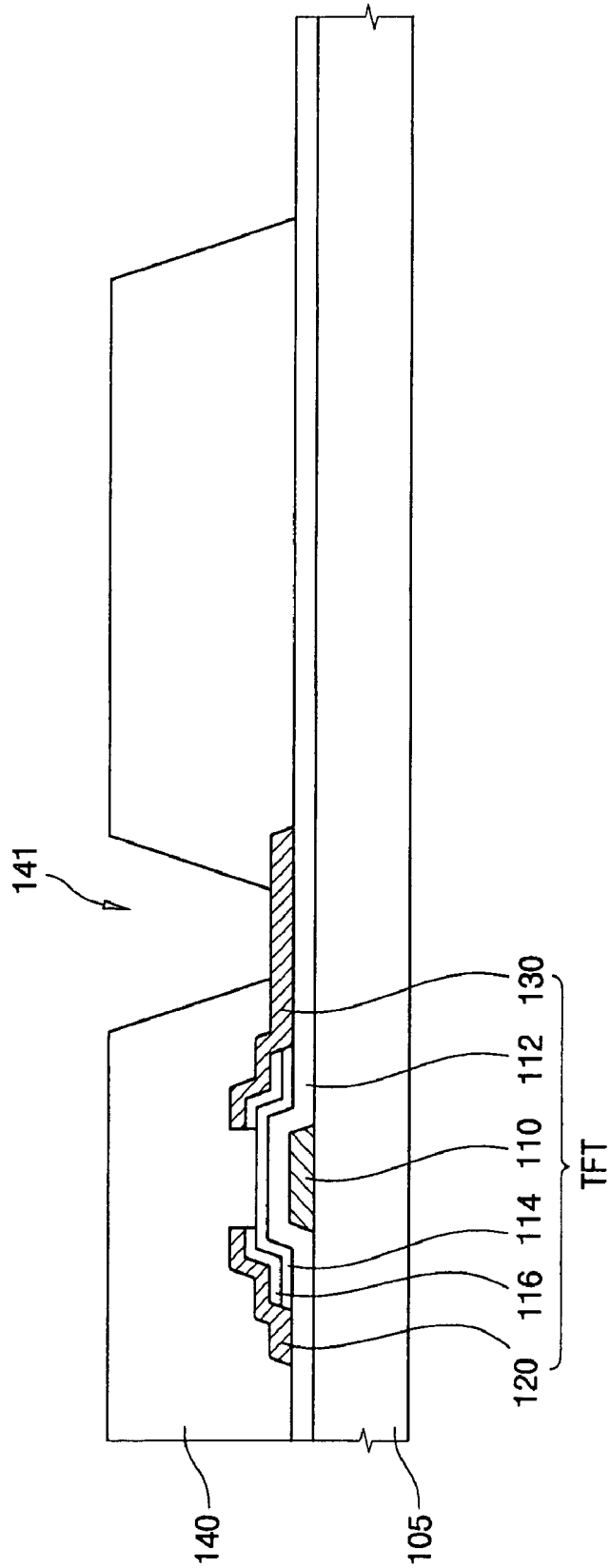

FIG. 9D

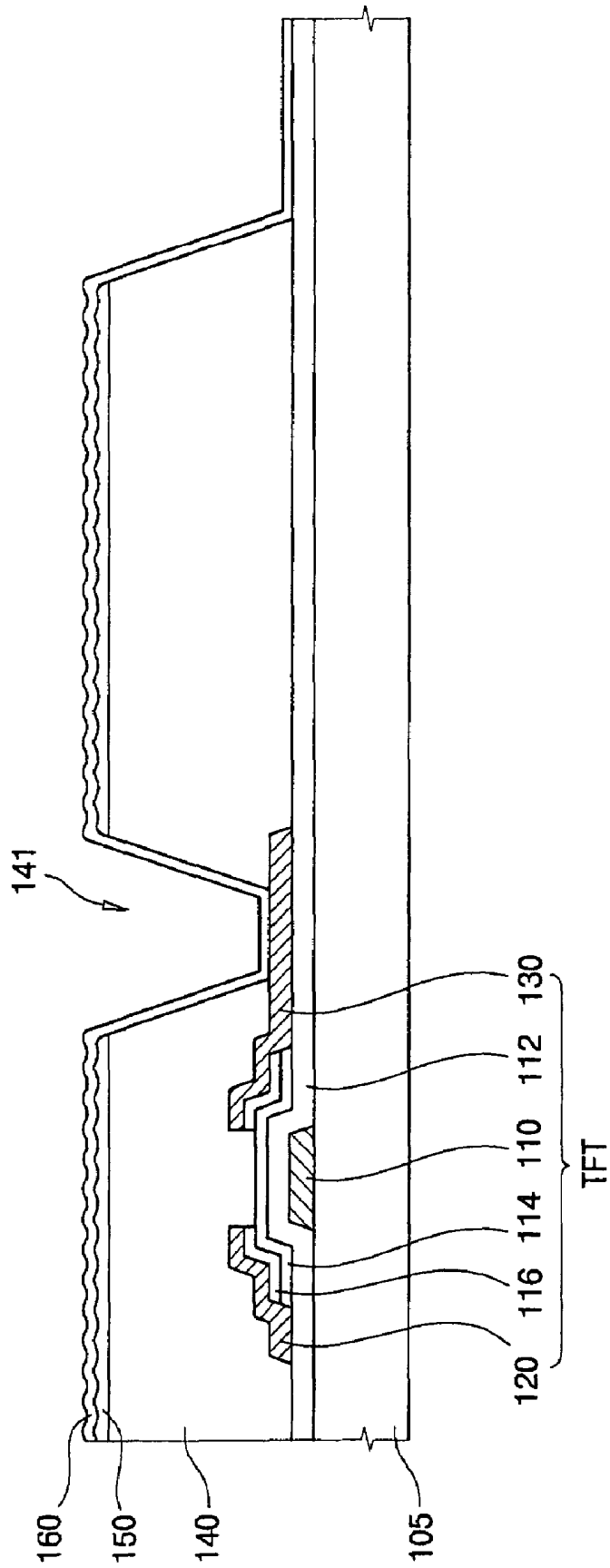

FIG. 9E

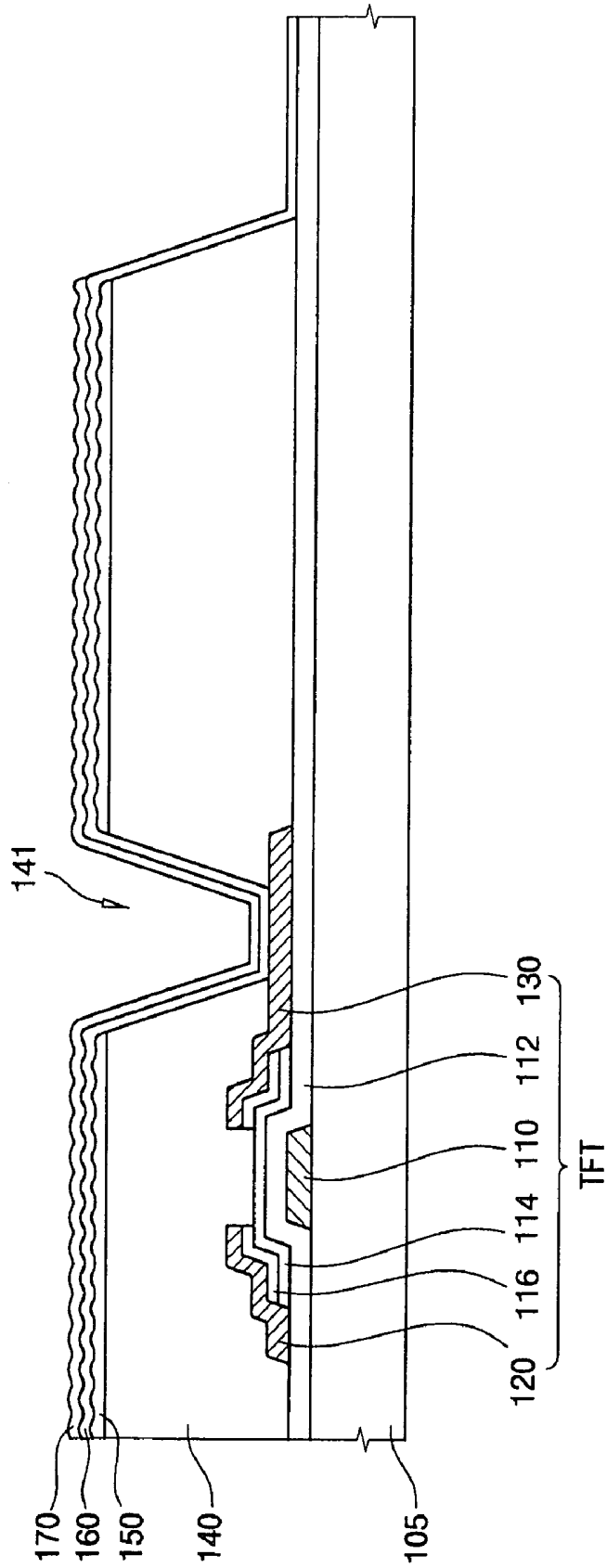

FIG. 10A

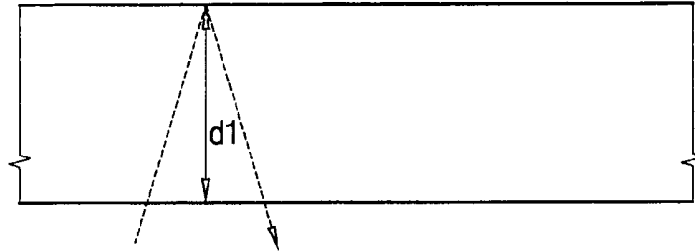

FIG. 10B

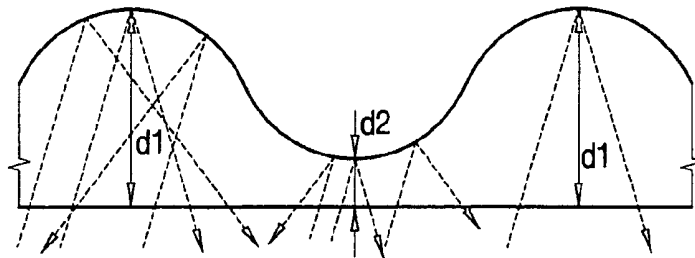

FIG. 10C

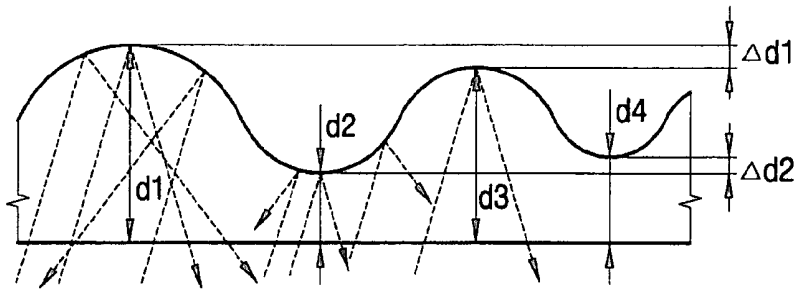

FIG. 10D

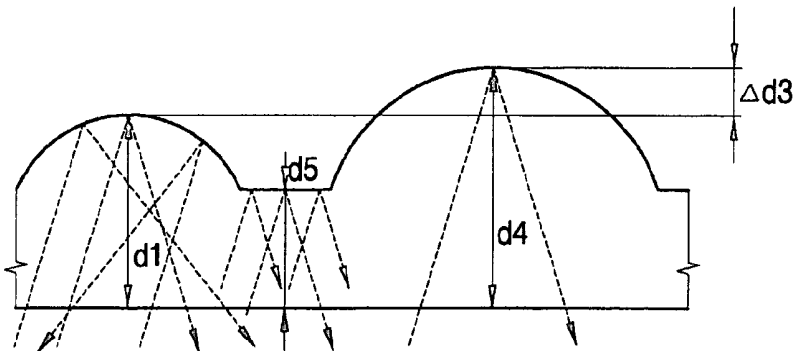

FIG. 11

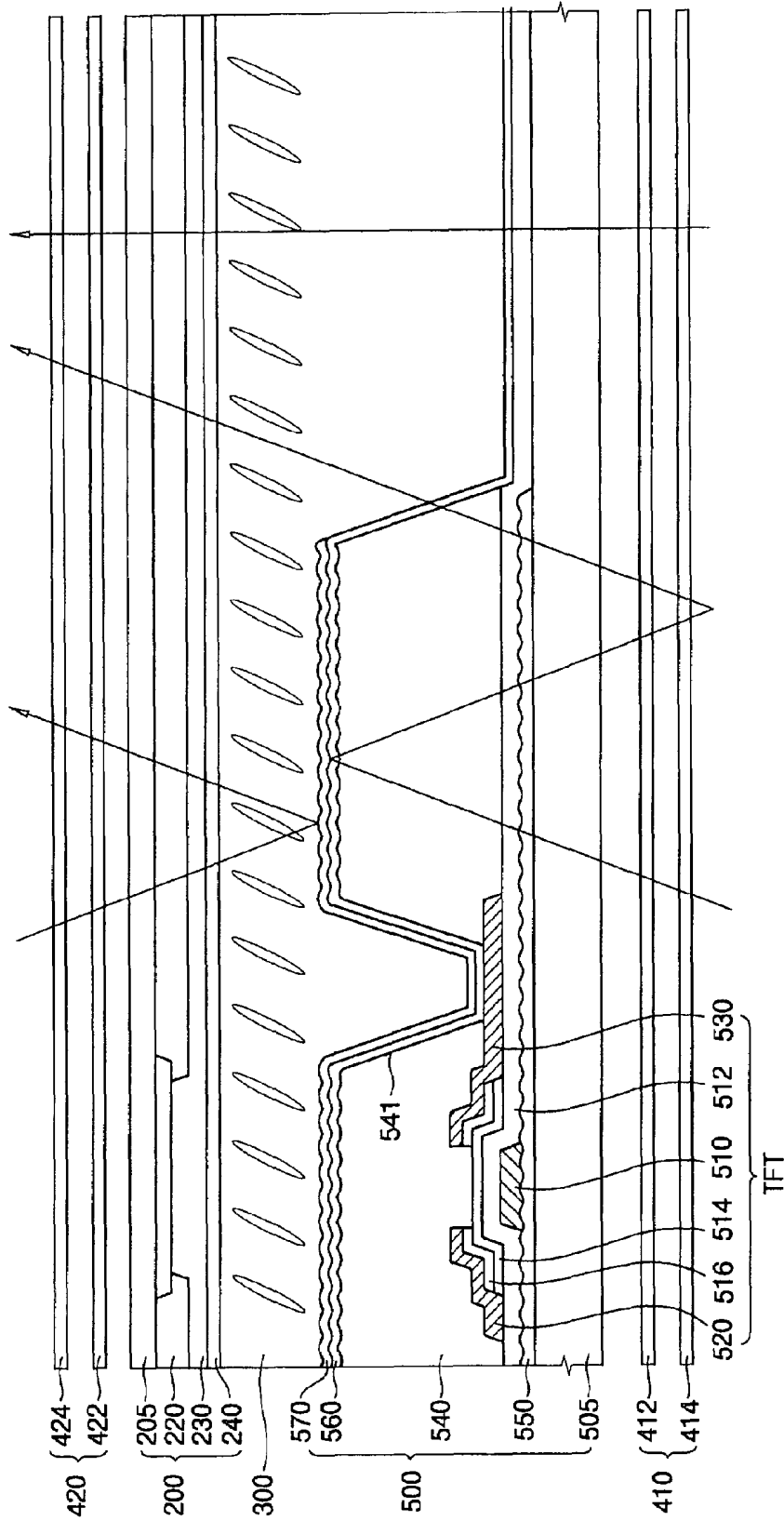

FIG. 12

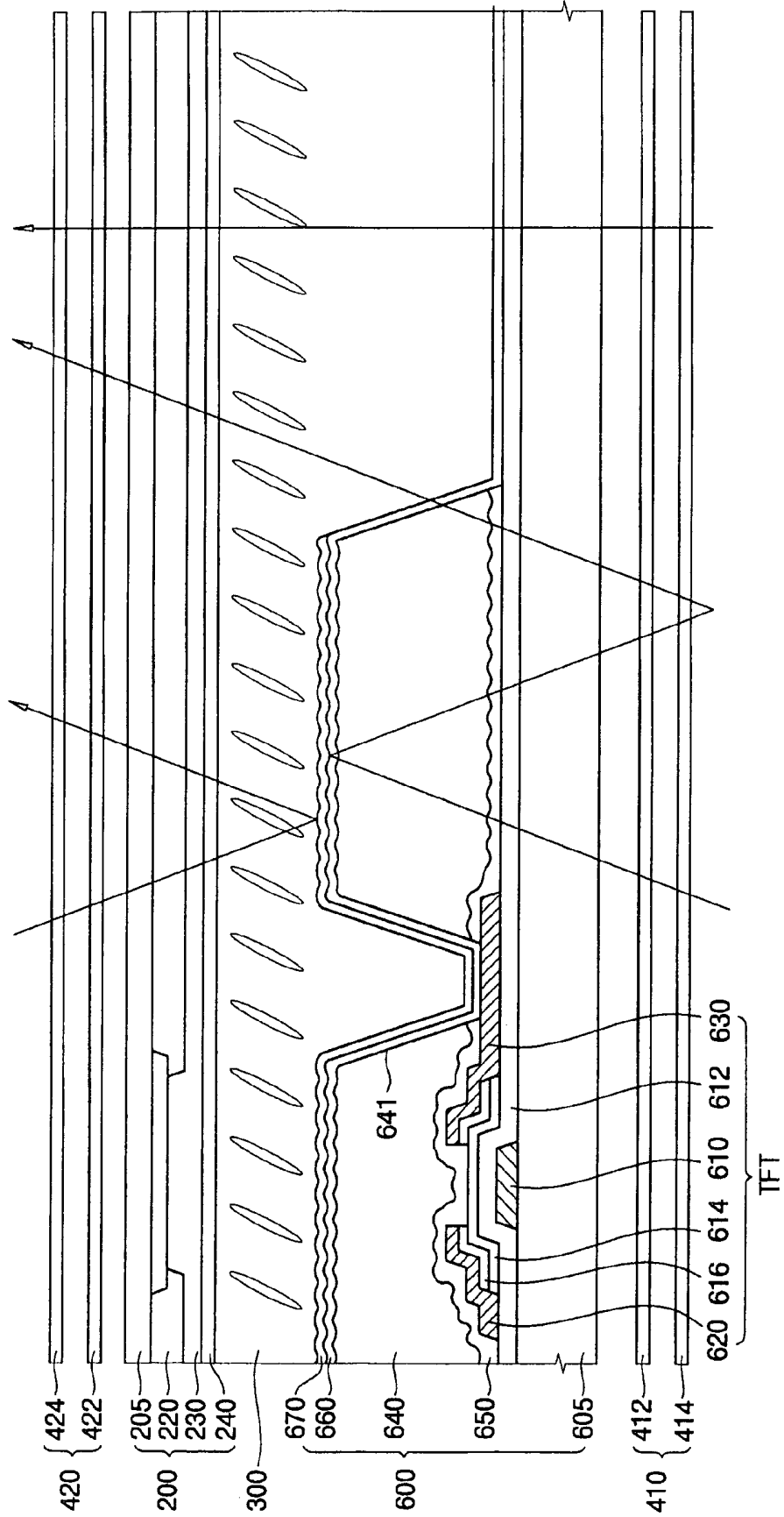

FIG. 13

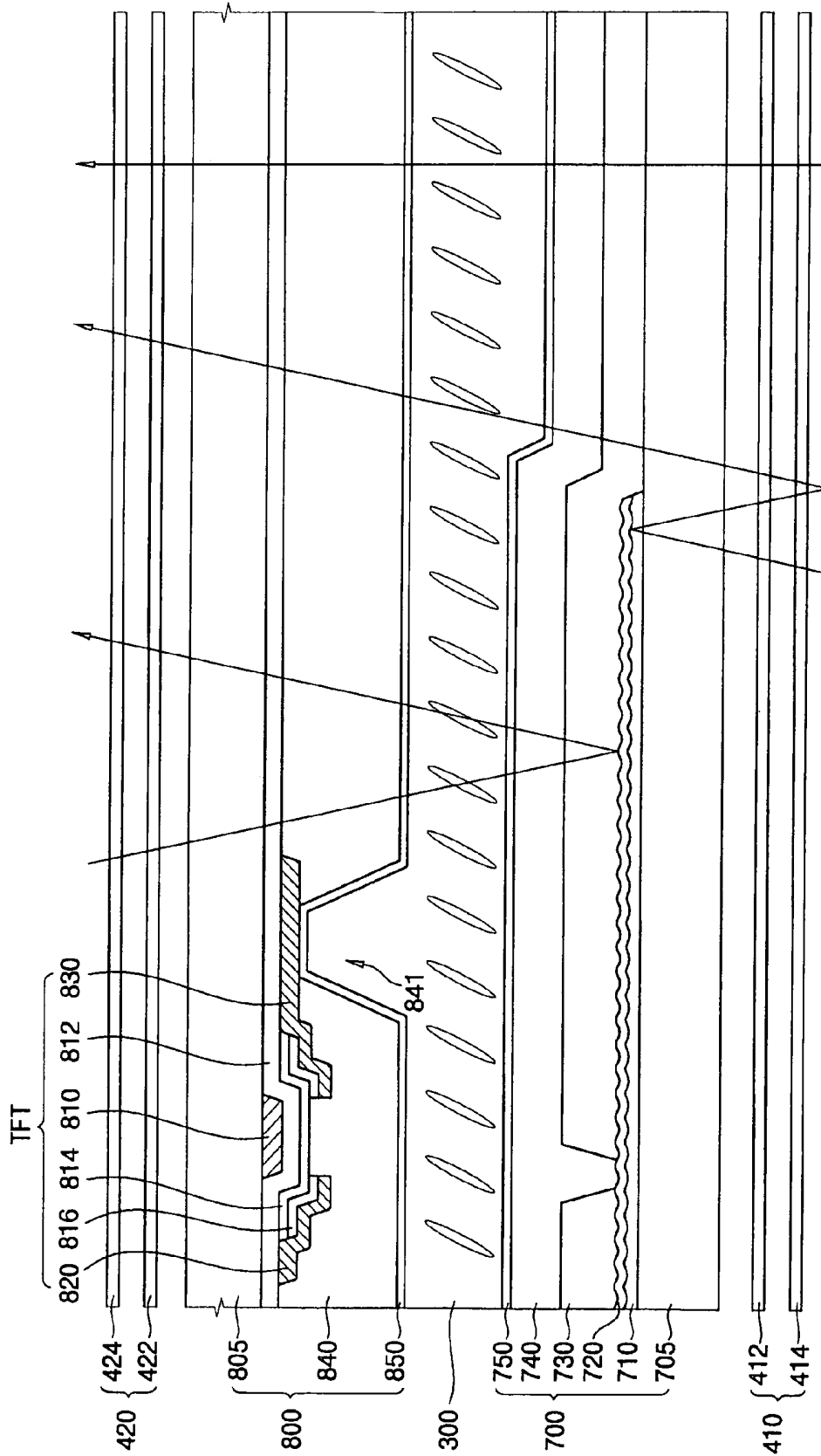
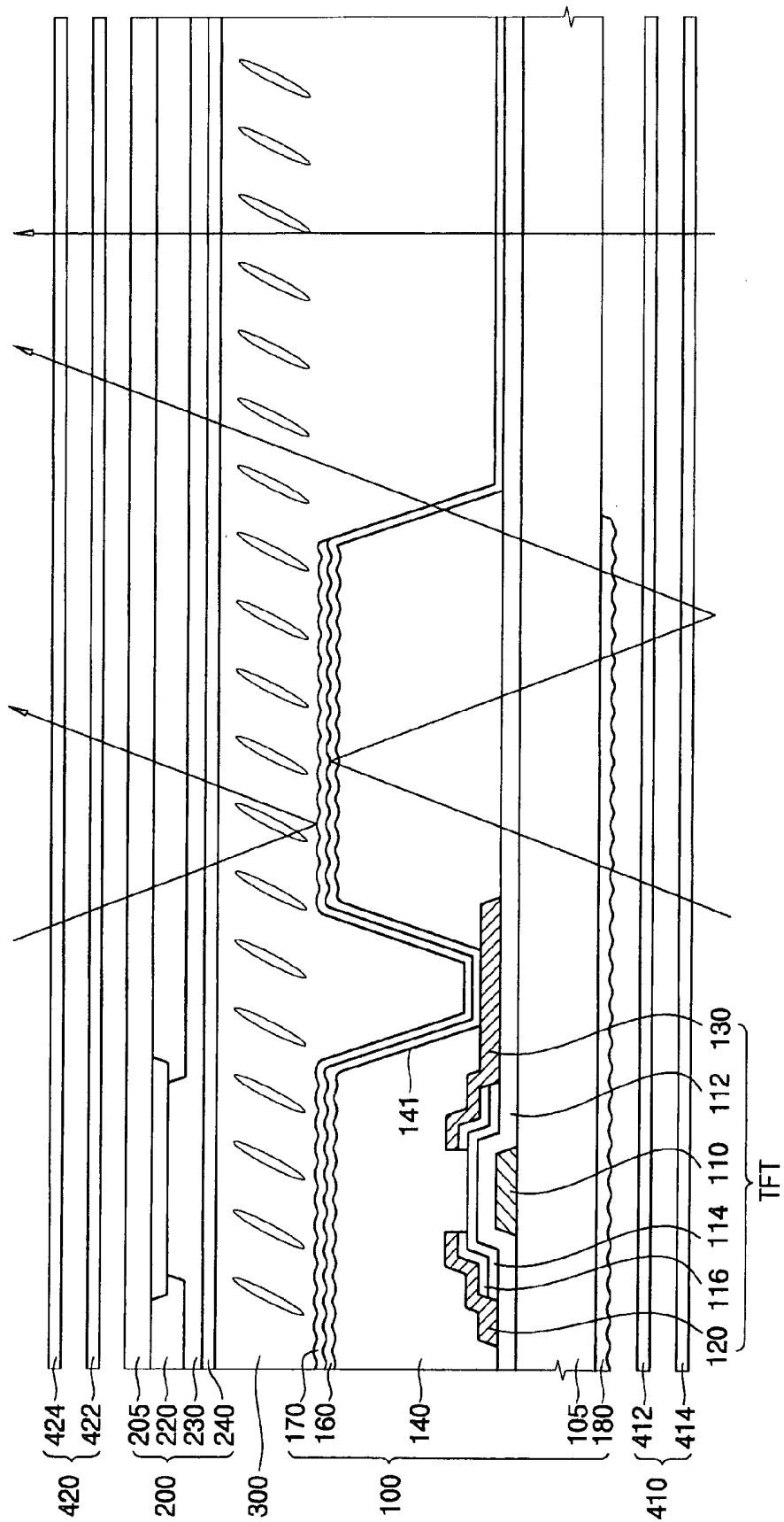

FIG. 14



**PHASE DELAY ELEMENT FOR
TRANSMISSIVE AND REFLECTIVE TYPE
LIQUID CRYSTAL DISPLAY**

BACKGROUND OF THE INVENTION

1. Field of the Invention

The present invention relates to a phase delay element for a liquid crystal display, and more particularly, to phase delay element for a transmissive and reflective type liquid crystal display in which the display operation is carried out in a reflection mode of a low power consumption at a bright place where a light amount is abundant and the display operation is also carried out in a transmission mode of a high luminance at a dark place where a light amount is deficient

2. Description of the Related Art

In an information-oriented society these days, the role of an electronic display is getting more important. All kinds of electronic displays are widely used in various industrial fields.

Generally, the electronic display is an apparatus for visually providing a variety of information to a person. In other words, an electrical information signal output from various electronic devices is converted into a visually recognizable optical information signal at the electronic display. Therefore, the electronic display serves as a bridge for connecting the person and the electronic devices.

Electronic displays are classified as either an emissive display in which the optical information signal is displayed by a light-emitting way, or a non-emissive display in which the optical information signal is displayed by an optical modulation way such as light-reflecting, dispersing and interfering phenomenon, etc. As the emissive display is known as an active display, for example, they include a CRT (Cathode Ray Tube), a PDP (Plasma Display Panel), an LED (Light Emitting Diode) and an ELD (Electroluminescent Display), etc. As the non-emissive display is known as a passive display, they include an LCD (Liquid Crystal Display), an ECD (Electrochemical Display) and an EPID (Electrophoretic Image Display), etc.

The CRT used in an image display, such as a television receiver and a monitor, for example, has the highest market share in an aspect of displaying quality and economical efficiency, but also has many disadvantages such as heavy weight, large volume and high power consumption.

Meanwhile, due to rapid developments in semiconductor technology, various kinds of electronic devices are driven by lower voltage and lower power, and thus the electronic equipments became much slimmer and lighter. Therefore, a flat panel type display having the slimmer and lighter characteristic, as well as the lower driving voltage and lower power consumption characteristic, is required according to the new environment.

The LCD among the various developed flat panel type displays is much slimmer and lighter than any other displays, and has a lower driving voltage and lower power consumption, and also has a display quality similar to that of the CRT. Therefore, the LCD is widely used in various electronic equipments.

The LCD is classified as either a transmission type LCD for displaying an image using an external light source such as a backlight assembly, a reflection type LCD for displaying an image using natural light, and a transmissive and reflective type LCD in which the display operates in a transmission mode using an internal light source provided in the display itself when indoors or in a dark place where an external light source does not exist and the display operates in a reflection

mode to display an image by reflecting an external incident light in a high brightness environment, such as outdoors.

The reflective type LCD apparatus, in general, displays an image using an external natural light or ambient light that is provided to the LCD apparatus. Therefore, the reflective type LCD apparatus may not display the image when the LCD apparatus is surrounded in darkness.

The transmissive type LCD apparatus displays an image using an artificial light that is generated from a backlight assembly internal to the LCD apparatus. Therefore, the transmissive type LCD apparatus can display the image when the LCD apparatus is surrounded in darkness. However, the transmissive type LCD apparatus has a larger power consumption than the reflective type LCD apparatus. In addition, the transmissive type LCD apparatus has a battery resulting in a heavier weight than the reflective type LCD apparatus. Therefore, the transmissive type LCD apparatus is not as desirable for use as a portable display apparatus compared with the reflective type LCD apparatus.

The LCD controls the alignment of liquid crystal molecules using a voltage applied to the liquid crystal layer, and can be classified as either a passive matrix type or an active matrix type, depending on the way the pixels are driven. In the passive matrix type, pixels are driven using a root-mean-square (rms) of a difference between voltages applied to signal lines and scanning lines while a line addressing in which a signal voltage is applied to all of the pixels at the same time is carried out. In the active matrix type, pixels are driven by a switching element such as a metal-insulator-metal (MIN) device or a thin film transistor (TFT).

FIG. 1 is a cross-sectional view showing a conventional reflective-transmissive type LCD apparatus. A portion of an artificial light, i.e., from a backlight assembly disposed at a rear side of the reflective-transmissive LCD apparatus, is lost.

Referring to FIG. 1, the reflective-transmissive LCD apparatus includes a lamp 1, a lamp reflecting plate 2, a lower polarizer 3, a retardation film 4, a reflection layer 5, a liquid crystal layer 6, a color filter 7, and an upper polarizer 8.

The lamp 1 is disposed on a backside of the lower polarizer 3 and intermediate thereof and the lamp reflecting plate 2. Lamp 1 supplies the lower polarizer 3 with an artificial light. The lower polarizer 3 has an absorption axis that is substantially perpendicular to a horizontal direction defining substantially parallel layers with respect to the reflective-transmissive LCD apparatus. When the artificial light generated from the lamp 1 is incident on the lower polarizer 3, a portion of the artificial light vibrating in the horizontal direction passes through the lower polarizer 3 and is emitted towards a viewer's side of the reflective-transmissive LCD apparatus. When the natural light that is provided from the exterior of the LCD apparatus is incident on the lower polarizer 3, a portion of the natural light vibrating in the horizontal direction passes through the lower polarizer 3 and is emitted towards the backside of the reflective-transmissive LCD apparatus.

The retardation film 4 includes a $\lambda/4$ wavelength phase retardation film 4. When the artificial light or the natural light passes through the $\lambda/4$ retardation film 4, a phase of the light is delayed by about $\lambda/4$ of the wavelength phase or $\lambda/4$. The $\lambda/4$ wavelength phase retardation film 4 functions to convert a linearly polarized light to a circularly polarized light, or vice versa by causing a phase difference of $\lambda/4$ wavelength between two polarization components that are normal to each other and are parallel to optical axes of the $\lambda/4$ wavelength phase retardation film 4.

The reflection layer 5 is disposed under the liquid crystal layer 6 and is intermediate the liquid crystal layer and the $\lambda/4$ wavelength phase retardation film 4 as illustrated. When a

vertically polarized light is incident on the reflection layer 5, the vertically polarized light is reflected from the reflection layer 5. A luminance of the vertically polarized light is controlled by the liquid crystal layer 6. More specifically, the arrangement of the liquid crystal layer 6 varies in response to an electric field applied thereto, thus allowing a light transmittance of the liquid crystal layer 6 to be changed. A portion of the vertically polarized light that passes through the liquid crystal layer is incident on the color filter 7 and, passes through the color filter 7, dependent on a predetermined wavelength range.

The upper polarizer 8 includes a vertical polarizing axis allowing a vertically polarized light to pass through the upper polarizer 8. When the vertically polarized light that is provided from the backside is incident on the upper polarizer 8, the vertically polarized light passes through the upper polarizer 8. In addition, when the natural light or a frontal light is incident on the upper polarizer 8, the vertically polarized light passes through the upper polarizer 8 and is incident on the color filter 7.

The artificial light corresponding to the transmissive mode has a lower efficiency than an efficiency of the natural light corresponding to the reflective mode. When the reflective-transmissive LCD apparatus is in the transmissive mode, the artificial light generated from the lamp 1 is incident on the lower polarizer 3 allowing the linearly polarized light to pass through the lower polarizer 3. The linearly polarized light is incident on the retardation film 4 allowing the right circularly polarized light to be emitted from the retardation film 4. A portion of the right circularly polarized light passes through a transmission window of the liquid crystal layer 6 having a wavelength phase of the light that is changed in response to the electric field applied to the liquid crystal layer 6.

When the right circularly polarized light passes through the liquid crystal layer 6, either the right circularly polarized light or the vertically polarized light is emitted from the liquid crystal layer 6 dependent on the electric field applied to the liquid crystal layer 6. In addition, it is noted that the vertically polarized light passes through the upper polarizer 8, while the right circularly polarized light may not pass through the upper polarizer 8.

A remaining portion of the right circularly polarized light that is emitted from the retardation film 4 is reflected from the reflection layer 5 and emitted therefrom as a left circularly polarized light. The left circularly polarized light is incident on the retardation film 4 so that the vertically polarized light is emitted from the retardation film 4 toward the lower polarizer 3. The vertically polarized light is blocked by the lower polarizer 3. Therefore, the remaining portion of the artificial light is lost, thus decreasing the efficiency of the lamp.

For example, when an effective display area is about 80% and the transmission window is about 30% of the unit pixel, more than about 70% of the unit pixel is therefore lost for transmission of artificial light.

Accordingly, there is a desire to improve a luminance of a reflective-transmissive LCD apparatus by increasing the efficiency of the artificial light reflected from the reflection layer.

BRIEF SUMMARY OF THE INVENTION

Accordingly, the present invention is to solve the aforementioned problems of the conventional art, and it is an object of the present invention to provide a transmissive and reflective type LCD capable of simplifying a structure of a liquid crystal cell and decreasing light loss in the transmission mode.

A transmissive and reflective type LCD in accordance with an exemplary embodiment of the present invention includes a first substrate and a second substrate having an inner surface that is arranged so as to face the first substrate. A liquid crystal layer is formed between the first substrate and the second substrate. A first polarizing plate is formed on an outer surface of the first substrate and a backlight is arranged at a rear side of the first polarizing plate. A brightness enhancement layer is arranged between the backlight and a reflection layer disposed with one of the liquid crystal layer and the first and second substrates. The brightness enhancement layer is configured to delay a phase of the light that has passed through the brightness enhancement layer by about $\frac{1}{4}$ phase ($\lambda/4$) so that a right circularly polarized light is emitted from the brightness enhancement layer toward a backside defining the first.

In a method of manufacturing a phase delay element in accordance with an aspect of the present invention, a liquid crystal layer is formed on an alignment layer disposed on a substrate. The liquid crystal layer is patterned and solidified to form a brightness enhancement layer. An embossed pattern is formed on the brightness enhancement layer.

A substrate in accordance with an aspect of the present invention includes an insulating plate, a switching element, a pixel electrode, a reflection layer and a brightness enhancement layer. The insulating plate includes a pixel area defined by a reflection region and a transmission window. The switching element is formed in the pixel area. The pixel electrode is electrically connected to the switching element. The reflection layer is disposed in alignment with the reflection region. The reflection layer is receptive to a front light emitted from a viewer's side outside the substrate being reflected from the reflection layer toward the viewer's side. The reflection layer is receptive to a backside light emitted from a backside of the substrate opposite the viewer's side being reflected from the reflection layer toward the backside. The brightness enhancement layer is formed intermediate the reflection layer and the backside light. The backside light is emitted from the backside toward the reflection layer through the brightness enhancement layer becomes a reflection light emitted from the reflection layer toward the backside through the brightness enhancement layer.

In a method of manufacturing a substrate in accordance with an aspect of the present invention, a switching element is formed including a pixel area, the pixel area defining a reflection region and a transmission region. A brightness enhancement layer is formed corresponding to the reflection region. The brightness enhancement layer receptive to delaying a phase of a backside light that passes through the brightness enhancement layer by about $\frac{1}{4}$ phase ($\lambda/4$). A pixel electrode is formed in the transmission region while a reflection layer is formed in the reflection region.

An LCD apparatus in accordance with an exemplary embodiment of the present invention includes a first side, a second side opposite the first side defining the LCD apparatus, a liquid crystal layer, a first polarizer, a lower $\frac{1}{4}$ phase ($\lambda/4$) retardation film, a brightness enhancement film and a reflection layer. The liquid crystal layer is proximate the second side and is receptive to displaying images. The first polarizer is receptive to emitting a horizontally polarized light when a light is incident on the first polarizer from either side of the first polarizer. The lower $\frac{1}{4}$ phase ($\lambda/4$) retardation film is intermediate the liquid crystal layer and the first polarizer and is receptive to emitting a circularly polarized light when the horizontally polarized light is incident on the lower $\frac{1}{4}$ phase ($\lambda/4$) retardation film from the first side. The horizontally polarized light is emitted from the lower $\frac{1}{4}$ phase ($\lambda/4$)

retardation film toward the first side when the circularly polarized light is incident on the lower $\frac{1}{4}$ phase ($\lambda/4$) retardation film from the second side. The brightness enhancement film is intermediate the liquid crystal layer and the $\frac{1}{4}$ phase ($\lambda/4$) retardation film and is receptive to emitting a vertically polarized light therefrom toward the second side when the circularly polarized light is incident on the brightness enhancement film from the first side. The brightness enhancement film is also receptive to emitting a circularly polarized light therefrom when the vertically polarized light is incident on the brightness enhancement film from the second side. The reflection layer is intermediate the liquid crystal layer and the brightness enhancement film and is receptive to reflecting the vertically polarized light to the brightness enhancement film, the vertically polarized light being incident on the reflection layer from the first side

A phase delay element for a LCD apparatus in accordance with an exemplary embodiment of the present invention includes a brightness enhancement layer disposed between a backlight and a reflection layer. The brightness enhancement layer is defined by a bottom member and a counter member, the counter member being integrally formed with the bottom member. The counter member is disposed facing the reflection layer, wherein a first light having a wavelength phase (λ) incident on the bottom member is delayed by about $\frac{1}{4}$ phase ($\lambda/4$) emitting a second light from the counter member toward the reflection layer. The second light is reflected from the reflection layer to become a third light that is emitted from the reflection layer toward the counter member. A phase of the third light is delayed by about $\frac{1}{4}$ phase ($\lambda/4$) passing through the brightness enhancement layer emitting a fourth light from the bottom member.

Therefore, the LCD apparatus includes the $\frac{1}{4}$ phase ($\lambda/4$) retardation film so that a portion of the artificial light, which is reflected from the reflection layer, is used to improve a luminance of the LCD apparatus.

The present application claims priority from Korean Patent Application No. 2004-55827, filed on Jul. 19, 2004, the disclosure of which is hereby incorporated herein by reference in its entirety.

BRIEF DESCRIPTION OF THE DRAWINGS

The above and other advantages of the present invention will become more apparent by describing in detail exemplary embodiments thereof with reference to the accompanying drawings, in which:

FIG. 1 is a cross-sectional view showing a conventional reflective-transmissive LCD apparatus;

FIG. 2 is a cross-sectional view showing an LCD apparatus in accordance with an exemplary embodiment of the present invention;

FIG. 3 is a plan view showing a molecular structure of a cholesteric liquid crystal in accordance with an exemplary embodiment of the present invention;

FIGS. 4A to 4F are cross-sectional views showing a method of manufacturing a brightness enhancement layer in accordance with an exemplary embodiment of the present invention;

FIGS. 5A to 5E are cross-sectional views showing a method of manufacturing a brightness enhancement layer in accordance with another exemplary embodiment of the present invention;

FIGS. 6A to 6F are cross-sectional views showing a method of manufacturing a brightness enhancement layer in accordance with another exemplary embodiment of the present invention;

FIGS. 7A to 7E are cross-sectional views showing a method of manufacturing a brightness enhancement layer in accordance with another exemplary embodiment of the present invention;

FIG. 8 is a cross-sectional view showing an LCD apparatus in accordance with an exemplary embodiment of the present invention;

FIGS. 9A to 9E are cross-sectional views showing a method of manufacturing an array substrate shown in FIG. 8;

FIGS. 10A to 10D are cross-sectional views showing brightness enhancement layers in accordance with alternative exemplary embodiments of the present invention;

FIG. 11 is a cross-sectional view showing an LCD apparatus in accordance with another exemplary embodiment of the present invention;

FIG. 12 is a cross-sectional view showing an LCD apparatus in accordance with another exemplary embodiment of the present invention;

FIG. 13 is a cross-sectional view showing an LCD apparatus in accordance with another exemplary embodiment of the present invention; and

FIG. 14 is a cross-sectional view showing an LCD apparatus in accordance with another exemplary embodiment of the present invention.

DESCRIPTION OF THE EXEMPLARY EMBODIMENTS

It should be understood that the exemplary embodiments of the present invention described below may be varied or modified in many different ways without departing from the inventive principles disclosed herein, and the scope of the present invention is therefore not limited to these particular following embodiments. Rather, these embodiments are provided so that this disclosure will be thorough and complete, and will fully convey the concept of the invention to those skilled in the art by way of example and not by way of limitation.

Referring to FIG. 2, a cross section view of an LCD apparatus is illustrated in accordance with an exemplary embodiment. The LCD apparatus includes a lamp 10, a lower polarizer 20, a retardation film 30, a brightness enhancement layer 40, a reflection layer 50, a lamp reflecting plate 11, a liquid crystal layer 70, a color filter 80 and an upper polarizer 90. In one embodiment, the upper polarizer 90 may be an analyzer. A viewer's side of the LCD apparatus corresponds to an upper portion or a top side of the LCD apparatus as illustrated. A backside of the LCD apparatus corresponds to a lower portion of the LCD apparatus as illustrated.

The lamp 10 is disposed under the lower polarizer 20, as illustrated, or is intermediate the lamp polarizer 20 and the lamp reflecting plate 60. Lamp 10 is configured to generate an artificial light that is a non-polarized light.

The lower polarizer 20 includes a horizontal polarizing axis indicated generally with arrow 22. When the artificial light is incident on the lower polarizer 20 from the backside, a horizontally polarized light is emitted from the lower polarizer 20 toward the viewer's side indicated generally with double-ended arrows 24. When the horizontally polarized light 24 is incident on the lower polarizer 20 from the viewer's side, the horizontally polarized light 24 is emitted from the lower polarizer 20 toward the backside. In this manner, the horizontally polarized light 24 is allowed to pass through the lower polarizer 20 from either side.

A phase of a wavelength of light that has passed through the retardation film 30 is delayed by about $\frac{1}{4}$ phase or $\lambda/4$. When the horizontally polarized light 24 is incident on the retardation film 30 from the backside, a phase of the horizontally

polarized light **24** is delayed by about $\frac{1}{4}$ phase ($\lambda/4$), thus emitting a right circularly polarized light indicated generally at **36** from the retardation film **30** towards the viewer's side. When the right circularly polarized light **36** is incident on the retardation film **30** from the viewer's side, the horizontally polarized light **24** is emitted from the retardation film **30** toward the backside.

A phase of the light that has passes through the brightness enhancement layer **40** is delayed by about $\frac{1}{4}$ phase ($\lambda/4$). When the right circularly polarized light **36** is incident on the brightness enhancement layer **40** from the backside, a phase of the right circularly polarized **36** light is delayed by about $\frac{1}{4}$ phase ($\lambda/4$), thus emitting a vertically polarized light from the bright enhancement layer **40** toward the viewer's side indicated generally at **44**. When a reflected vertically polarized light **36** that is reflected from the reflection layer **50** is incident on the brightness enhancement layer **40** from the viewer's side, a phase of the reflected vertically polarized light is delayed about $\frac{1}{4}$ phase ($\lambda/4$) emitting the right circularly polarized light **36** from the brightness enhancement layer **40** toward the backside.

In an exemplary embodiment, the brightness enhancement layer **40** includes a birefringent film, an alignment film of a liquid crystal polymer, and an alignment layer of the liquid crystal polymer that is fixed using a film, for example. A polymer film may be extended in a predetermined direction to form the birefringent film. The polymer film may include polycarbonate, polyvinylalcohol, polystyrene, polymethylmethacrylate, polypropylene, polyolefin, polyacrylate, polyamide, for example, but is not limited thereto.

In one exemplary embodiment referring to FIG. 3, the brightness enhancement layer **40** includes a cholesteric liquid crystal that is an ultraviolet curable liquid crystal polymer. FIG. 3 illustrates a plan view showing a molecular structure of a cholesteric liquid crystal. Directions of molecules **96** of the cholesteric liquid crystal are gradually changed along a spiral axis (not shown) having a pitch (P). The spiral axis corresponds to a direction of the light that passes through the cholesteric liquid crystal. In particular, a portion of a nematic liquid crystal is changed to have a chiral structure that has a spiral shape, thereby forming the liquid crystal. One layer of the cholesteric liquid crystal is substantially identical to a plan view of the nematic liquid crystal, however, the nematic liquid crystal does not have the spiral axis.

Referring again to FIG. 2, the reflection layer **50** is disposed under the liquid crystal layer **70** as illustrated or is intermediate the liquid crystal layer and brightness enhancement layer **40**. When the vertically polarized light **44** is reflected from the reflection layer **70**, the phase of the vertically polarized light is not changed.

The lamp reflecting plate **60** is disposed under the lamp **10** and defines the backside of the LCD apparatus. When the artificial light generated from lamp **10** or the vertically polarized light **44** from the viewer's side is incident on the lamp reflecting plate **11**, the artificial light is reflected from the lamp reflecting plate **60** toward the viewer's side without change to the phase of the artificial light. The reflected vertically polarized light then consequently passes through the bright enhancement layer **40**, the retardation film **30** and the lower polarizer **20**.

The liquid crystal layer **70** controls the phase of the vertically polarized light **44** that is provided from the backside based on an electric field applied to the liquid crystal layer **70** and emitting a light incident on the color filter **80** having the changed phase. Therefore, a light transmittance of the liquid crystal layer **70** may be changed. A thickness of the liquid crystal layer **70** is referred to as a cell gap. The cell gap of the

liquid crystal layer **70** corresponding to the reflection region may be different from the cell gap of the liquid crystal layer **70** corresponding to the transmission region. In this exemplary embodiment, the cell gap of the reflection region is about a half of the cell gap of the transmission region.

A portion of the vertically polarized light **44** that has passed through the liquid crystal layer **70**, which has a predetermined wavelength range, passes through a corresponding portion of the color filter **80**. More specifically, the color filter **80** includes a red color filter portion, a green color filter portion and a blue color filter portion. For example, a red light having about 650 nm of the wavelength is allowed to pass through the red color filter portion. A green light having about 550 nm of the wavelength is allowed to pass through the green color filter portion. A blue light having about 450 nm of the wavelength is allowed to pass through the blue color filter portion. In this exemplary embodiment, the color filter **80** is disposed on the liquid crystal layer **70** as illustrated, or is intermediate the liquid crystal layer **70** and the upper polarizer **90**. Alternatively, the color filter **80** may be disposed under the liquid crystal layer **70** being intermediate thereof and the reflection layer **50**.

The upper polarizer **90** includes a vertically polarizing axis **92**. When a light is incident on the upper polarizer **90** from the backside, a vertically polarized light is emitted from the upper polarizer **90** toward the viewer's side. When a natural light or a front light is incident on the upper polarizer **90** from the viewer's side, the vertically polarized light is emitted from the upper polarizer **90** and is incident on the color filter **80**. In this exemplary embodiment, the polarizing axis **92** of the upper polarizer **90** is substantially perpendicular to the polarizing axis **22** of the lower polarizer **20**. The natural light may include sunlight or an illumination light from a front, for example, but is not limited thereto. Further, the front light may be an artificial light generated from an auxiliary lamp (not shown) disposed on a viewer's side of the LCD apparatus. Still referring to FIG. 2, the overall operation of the brightness enhancement layer **40** will now be described herein below. When the artificial light generated from the lamp **10** is incident on the lower polarizer **20**, the horizontally polarized light **24** is emitted from the lower polarizer **20** toward the retardation film **30**. When the horizontally polarized light **24** is incident on the retardation film **30**, the right circularly polarized light **36** is emitted from the retardation film **30** toward the brightness enhancement layer **40**. When the right circularly polarized light **36** is incident on the brightness enhancement layer **40**, the vertically polarized light **44** is emitted from the brightness enhancement layer **40** toward the reflection layer **50**. The vertically polarized light **44** is reflected from the reflection layer **50** so that the reflected light is incident on the brightness enhancement layer **40**. The vertically polarized light **44** may be reflected and scattered. The linearly polarized light (e.g., horizontally and vertically polarized lights **24** and **44**, respectively) is a P-wave, and the circularly polarized light **36** is a S-wave.

When the reflected light from the reflection layer **50** is incident on the brightness enhancement layer **40**, the right circularly polarized light **36** is emitted from the brightness enhancement layer **40** toward the retardation film **30**. When the right circularly polarized light **36** is incident on the retardation film **30**, the horizontally polarized light **24** is emitted from the retardation film **30**. The horizontally polarized light **24** passes through the lower polarizer **20**, and the horizontally polarized light **24** is reflected from the lamp reflecting plate **60**. The reflected horizontally polarized light is incident on the lower polarizer **20**, thus increasing a luminance of the LCD apparatus.

In this exemplary embodiment, the brightness enhancement layer **40** is disposed in the reflection region. Alternatively, the brightness enhancement layer may be disposed in the reflection region and the transmission region.

In another exemplary embodiment, the brightness enhancement layer **40** may be disposed in the liquid crystal layer **70**. The brightness enhancement layer may also be disposed on a lower substrate of the LCD apparatus using a film.

The cell gap of the liquid crystal layer **70** is determined by an anisotropy of the reflective index Δn . In this exemplary embodiment, the cell gap of the transmission region of the liquid crystal layer **70** is about $4\ \mu\text{m}$ to about $6\ \mu\text{m}$, and the cell gap of the reflection region of the liquid crystal layer **70** is about $2\ \mu\text{m}$ to about $3\ \mu\text{m}$. Referring to FIG. 2, the brightness enhancement layer **40** may constitute about $2\ \mu\text{m}$ to about $3\ \mu\text{m}$ of the $\frac{1}{4}$ phase ($\lambda/4$) retardation film **30**. A polycarbonate is extended in a predetermined direction to form the $\frac{1}{4}$ phase ($\lambda/4$) retardation film **30**. The $\frac{1}{4}$ phase ($\lambda/4$) retardation film **30** may also be formed by aligning the liquid crystal.

The $\frac{1}{4}$ phase ($\lambda/4$) retardation film **30** having the extended polycarbonate may have about 0.001 of the anisotropy of the reflective index Δn . When the anisotropy of the reflective index Δn and a reference wavelength are about 0.001 and about $560\ \text{nm}$, respectively, the thickness of the $\frac{1}{4}$ phase ($\lambda/4$) retardation film **30** corresponding to a light having a wavelength of about $140\ \text{nm}$ may be $140\ \mu\text{m}$.

The $\frac{1}{4}$ phase ($\lambda/4$) retardation film **30** having the aligned liquid crystal may have about 0.1 of the anisotropy of the reflective index Δn . When the anisotropy of the reflective index Δn and a reference wavelength are about 0.1 and about $560\ \text{nm}$, respectively, the thickness of the $\frac{1}{4}$ phase ($\lambda/4$) retardation film **30** corresponding to a light having a wavelength of about $140\ \text{nm}$ may be $1.4\ \mu\text{m}$.

FIGS. 4A to 4F are cross-sectional views illustrating a method of manufacturing a brightness enhancement layer **40** in accordance with an exemplary embodiment of the present invention.

Referring to FIG. 4A, an alignment film **211** is formed on a substrate film **210** for printing. An ultraviolet curable liquid crystal polymer is coated on the alignment film **211** to form an aligned liquid crystal layer **212**. The ultraviolet curable liquid crystal polymer may include the cholesteric liquid crystal illustrated in FIG. 3.

Referring to FIG. 4B, an ultraviolet light indicated generally with rays **200** is irradiated on the aligned liquid crystal layer **212** to form a semi-solid liquid crystal layer **213**. The semi-solid liquid crystal layer **213** may be a biaxial film or a uniaxial film. For example, a polarized ultraviolet light may be irradiated on the cholesteric liquid crystal to form the biaxial film. A non-polarized ultraviolet light may be irradiated on the cholesteric liquid crystal to form a C-plate. A "C-plate" denotes a birefringent optical element, such as, for example, a plate or film, with a principle optical axis (often referred to as the "extraordinary axis") substantially perpendicular to the selected surface of the optical element. The principle optical axis corresponds to the axis along which the birefringent optical element has an index of refraction different from the substantially uniform index of refraction along directions normal to the principle optical axis.

The biaxial film has an x-refractive index (n_x), a y-refractive index (n_y), and a z-refractive index (n_z) that are different from one another. The uniaxial film includes an A-plate and the C-plate. An "A-plate" denotes a birefringent optical element, such as, for example, a plate or film, having its principle optical axis within the x-y plane of the optical element. Positively birefringent a-plates can be fabricated using, for

example, uniaxially stretched films of polymers such as, for example, polyvinyl alcohol, or uniaxially aligned films of nematic positive optical anisotropy LCP materials. Negatively birefringent a-plates can be formed using uniaxially aligned films of negative optical anisotropy nematic LCP materials, including for example discotic compounds. A y-refractive index of the A-plate is substantially equal to a z-refractive index of the A-plate, and the y-refractive index of the A-plate is smaller than a z-refractive index of the A-plate. A x-refractive index of the C-plate is substantially equal to a y-refractive index of the C-plate, and the y-refractive index of the C-plate is larger than a z-refractive index of the C-plate.

Referring to FIG. 4C, the semi-solid liquid crystal layer **213** is disposed on a glass plate **214**. The glass plate **214** includes a reflection region or reflection area (RA) and a transmission region or transmission area (TA). The semi-solid liquid crystal layer **213** is heated or compressed to fix the semi-solid liquid crystal layer **213** to the glass plate **214**.

Referring to FIG. 4D, the substrate film **210** for printing is then detached from the alignment film **211** forming the semi-solid liquid crystal layer **213** on the glass plate **214**.

Referring to FIG. 4E, a reticle **218** having a transparent plate **215** and an opaque pattern **216** is aligned over the glass plate **214**. The opaque pattern **216** corresponds to the reflection region RA and is aligned therewith. Alternatively, the opaque pattern **216** may correspond to and be aligned with the transmission region TA. When the ultraviolet light **200** is irradiated on the semi-solid liquid crystal layer **213** through the reticle **218** during a developing process, the semi-solid liquid crystal layer **213** is developed. Therefore, a portion of the semi-solid liquid crystal layer **213** corresponding to the reflection region RA is solidified, and a remaining portion of the semi-solid liquid crystal layer **213**, corresponding to the transmission region TA, is removed. The alignment film **211** is also removed during the developing process.

Referring to FIG. 4F, a brightness enhancement layer **217** is illustrated as being an embossed pattern formed on an exposed surface of the solidified liquid crystal layer disposed in the reflection region RA.

FIGS. 5A to 5E are cross-sectional views illustrating a method of manufacturing a brightness enhancement layer in accordance with another exemplary embodiment of the present invention.

Referring to FIG. 5A, an alignment layer **221** is formed on a photoresist film **220** having an embossed pattern. A liquid crystal layer **222** is formed on the alignment layer **221** such that the alignment layer **221** is intermediate the photoresist film **220** and the liquid crystal layer **222**.

Referring to FIG. 5B, an exposed surface of the liquid crystal layer **222** is then disposed to a glass plate **223**. An ultraviolet light **200** is irradiated on the liquid crystal layer **222** to semi-solidify the liquid crystal layer **222**, which may be a biaxial film or a uniaxial film. For example, a polarized ultraviolet light may be irradiated on a cholesteric liquid crystal of the liquid crystal layer **222** to form the biaxial film. Alternatively, a non-polarized ultraviolet light may be irradiated on the cholesteric liquid crystal to form a C-plate.

Referring to FIG. 5C, the photoresist film **220** is illustrated as being removed from the alignment layer **221**.

Referring to FIG. 5D, a reticle **228** having a transparent plate **224** and an opaque pattern **225** is disposed over the alignment layer **221**. The opaque pattern **225** corresponds to and is aligned with the reflection region RA. Alternatively, the opaque pattern **225** may correspond to the transmission region TA. When the ultraviolet light **200** is irradiated on the semi-solid liquid crystal layer **222'** through the reticle, the semi-solid liquid crystal layer **222'** is developed. Therefore, a

portion of the semi-solid liquid crystal layer **222'** corresponding to the reflection region RA is then solidified, and a remaining portion of the semi-solid liquid crystal layer **222'**, corresponding to the transmission region TA, is removed. The alignment film **221** is also removed during this developing process.

FIG. 5E illustrates a completed brightness enhancement layer **226** having the embossed pattern on an exposed surface thereof.

FIGS. 6A to 6F are cross-sectional views illustrating another method of manufacturing a brightness enhancement layer in accordance with another exemplary embodiment of the present invention.

Referring to FIGS. 6A and 6B, an alignment layer **231** is formed on a plate **230** having a reflection region (RA) and a transmission region (TA). A liquid crystal layer **232** is formed on the alignment layer **231**, which is intermediate the liquid crystal layer **232** and the plate **230**.

Referring to FIG. 6C, a reticle **238** having a first transparent plate **234** and an opaque pattern **235** is disposed over the plate **230**, as illustrated. The opaque pattern **235** corresponds to and is aligned with the reflection region RA. Alternatively, the opaque pattern **235** may correspond to the transmission region TA. When the ultraviolet light **200** is irradiated on the liquid crystal layer **232** through the reticle, the liquid crystal layer **232** is developed. Therefore, a portion of the liquid crystal layer **232** corresponding to the reflection region RA is solidified, and a remaining portion of the liquid crystal layer **232** corresponding to the transmission region TA is removed. The alignment film **231** may not be removed during this developing process. FIG. 6D illustrates a completed brightness enhancement layer pattern **232** formed through the developing process.

Referring to FIG. 6E, a reticle **239** having a second transparent plate **236** and a plurality of opaque members **237** is disposed over the plate **230**. The opaque members **237** correspond to and are aligned with the reflection region RA. When the ultraviolet light **200** is irradiated on the liquid crystal layer **232** through the reticle **239**, the liquid crystal layer **232** is developed. Therefore, an embossed pattern is formed on an exposed surface of the brightness enhancement layer pattern **232** forming a brightness enhancement layer **233** (see FIG. 6F). FIG. 6F also illustrates an absence of a portion of the alignment film **231** corresponding to and aligned with the transmission region TA that has been removed.

FIGS. 7A to 7E are cross-sectional views illustrating another method of manufacturing a brightness enhancement layer in accordance with another exemplary embodiment of the present invention.

Referring to FIG. 7A, a photoresist alignment layer **241** is formed on a plate **240** having a reflection region RA and a transmission region TA.

Referring to FIG. 7B, a reticle **248** having a transparent plate **242** and an opaque pattern **243** is disposed over the plate **240**. The opaque pattern **243** corresponds to and is aligned with the transmission region TA. Alternatively, the opaque pattern **243** may correspond to and be aligned with the reflection region RA. When ultraviolet light **200** is irradiated on the photoresist alignment layer **241** through the reticle **248**, the photoresist alignment layer **241** is developed. Therefore, a portion of the photoresist alignment layer **241** corresponding to the reflection region RA is removed, and a remaining portion of the photoresist alignment layer **241** corresponding to the transmission region TA is solidified.

Referring to FIG. 7C, a liquid crystal layer **244** is then formed over the plate **240** having the photoresist alignment layer **241** corresponding to and aligned with the reflection region RA.

Referring to FIG. 7D, the ultraviolet light **200** is shown selectively irradiated on a portion of the liquid crystal layer **244** in the reflection region RA, thereby developing the liquid crystal layer **244**. The ultraviolet light **200** may be irradiated on the liquid crystal layer **244** through a reticle (not shown). After selective irradiation in the reflection region RA, a portion of the liquid crystal layer **244** corresponding to the transmission region TA is removed. A remaining portion of the liquid crystal layer **244** corresponding to the reflection region RA is solidified, thereby forming a brightness enhancement layer pattern **245**.

Referring to FIG. 7E, an embossed pattern is formed on an exposed surface of the brightness enhancement layer pattern **245** forming a completed brightness enhancement layer **246**.

Referring to FIG. 8 a cross-sectional view of an LCD apparatus in accordance with an exemplary embodiment of the present invention is illustrated. The LCD apparatus includes a reflective-transmissive array substrate having a top transparent conductive oxide such as indium tin oxide (ITO). In this embodiment, a brightness enhancement layer is formed on an organic insulating layer corresponding to a reflection region.

The LCD apparatus includes an array substrate **100**, a color filter substrate **200**, a liquid crystal layer **300** disposed between the array substrate **100** and the color filter substrate **200**, a lower film assembly **410** and an upper film assembly **420**. The lower film assembly **410** and an upper film assembly **420** are disposed at opposite ends of the LCD apparatus proximate a backside and a topside thereof, respectively.

The array substrate **100** includes a lower transparent plate **105**, a thin film transistor (TFT) disposed on the lower transparent plate **105**, an organic insulating layer **140**, a brightness enhancement layer **150**, a pixel electrode **160** and a reflection layer **170**, disposed in ascending order as illustrated. The TFT includes a gate electrode **110** formed on the lower transparent plate **105**, a gate insulating layer **112** formed on the lower transparent plate **105** having the gate electrode **110**, a semiconductor layer **114**, an ohmic contact layer **116**, a source electrode **120**, and a drain electrode **130**. The organic insulating layer **140** is disposed over the TFT. The drain electrode **130** and the gate insulating layer **112** corresponding to the reflection region are partially exposed through a contact hole **141** and an opening of the organic insulating layer **140**, respectively.

The brightness enhancement layer **150** is formed on the organic insulating layer **140** and has an uneven thickness or a non-planar surface. In one embodiment, convex and concave portions may be formed along a length on the organic insulating layer **140** defining the uneven thickness or non-planar surface. Alternatively, the brightness enhancement layer **150** may be formed on the organic insulating layer having an even thickness. In the exemplary embodiment illustrated in FIG. 8, the brightness enhancement layer **150** has an embossed pattern. Therefore, when a light that passes through the brightness enhancement layer **150** is reflected from the reflection layer **170** and passes through the brightness enhancement layer **150** toward the backside of the LCD apparatus, the light passes through various light paths as a result of the uneven brightness enhancement layer **150** having various optical characteristics Δn . The various optical characteristics Δn is a product of a refractive anisotropy Δn and a thickness d of the liquid crystal layer.

The pixel electrode **160** is formed over the brightness enhancement layer **150** such that a portion of the enhancement layer is exposed through the opening of the brightness enhancement layer **150**, the organic insulating layer **140**, and the contact hole **141** allowing electrical connection between the pixel electrode **160** and the drain electrode **130** of the TFT. In this exemplary embodiment, the pixel electrode **160** is electrically connected to the drain electrode **130** of the TFT through the contact hole **141**. The reflection layer **170** is formed on the pixel electrode **160** and corresponds to the reflection region. A transmission window is defined by an absence of the reflection layer **170**.

The pixel electrode **160** is a transparent electrode that includes a conductive oxide film such as indium tin oxide (ITO), tin oxide (TO), indium zinc oxide (IZO), zinc oxide (ZO), and the like, for example. A capacitor line (not shown) may be formed between the organic insulating layer **140** and the pixel electrode **160** in a region spaced apart from the TFT so that the capacitor line and a portion of the pixel electrode **160** form a storage capacitor C_{st} . In this exemplary embodiment illustrated in FIG. 8, the reflection layer **170** is formed on the pixel electrode **160**. In an alternative embodiment, an insulating layer may be disposed between the reflection layer **170** and the pixel electrode **160**.

The color filter substrate **200** intermediate the liquid crystal layer **300** and the upper film assembly **420** includes an upper transparent plate **205**, a black matrix **210**, a color filter **220**, a surface protection layer **230** and a common electrode **240** disposed in descending order, as illustrated. The black matrix **210** is formed on the upper transparent plate **205** to define a red pixel region, a green pixel region and a blue pixel region (e.g., for preventing a light from being leaked between pixels). The color filter **220** includes a red color filter portion disposed in the red pixel region, a green color filter portion disposed in the green pixel region and a blue color filter portion disposed in the blue pixel region. The surface protection layer **230** is formed on the upper transparent plate **205** having the black matrix **210** and the color filter **220** to protect the black matrix **210** and the color filter **220**. The common electrode **240** is formed on the surface protection layer **230**. In an alternative embodiment, at least two of the red, green and blue color filter portions are overlapped to form the black matrix **210**.

The liquid crystal layer **300** disposed between the array substrate **100** and the color filter substrate **200** is configured to vary an arrangement of liquid crystal in the liquid crystal layer **300** in response to an electric field applied thereto. The electric field is formed by a voltage difference between the pixel electrode **160** of the array substrate **100** and the common electrode **240** of the color filter substrate **200** disposed on either side of the liquid crystal layer **300**. In this manner, the liquid crystal layer **300** allows a front light to pass through the color filter substrate **200** or a backside light to pass through the transmission window defined by the absence of reflection layer **170**.

A portion of the liquid crystal layer **300** corresponding to the contact hole **141** in the reflection region, a portion of the liquid crystal layer **300** corresponding to a remaining region of the reflection region, and a portion of the liquid crystal layer **300** corresponding to the transmission window all have different cell gaps relative to one another. A first cell gap $d1$ of the liquid crystal layer **300** corresponding to the contact hole **141** is larger than a second cell gap $d2$ of the liquid crystal layer **300** corresponding to the remaining region of the reflection region. A third cell gap $d3$ of the liquid crystal layer **300**

corresponding to the transmission window is no smaller than the first cell gap $d1$ of the liquid crystal layer **300** corresponding to the contact hole **141**.

It will be recognized that an optical characteristic $\Delta n1$ of the liquid crystal layer **300** corresponding to the contact hole **141** is substantially equal to an anisotropy of a reflective index Δn multiplied by the first cell gap $d1$. Likewise, optical characteristics $\Delta n2$ and $\Delta n3$ of the liquid crystal layer **300** corresponding to the remaining region of the reflection region and transmission window are substantially equal to the anisotropy of the reflective index Δn multiplied by the second cell gap $d2$ and the third cell gap $d3$, respectively.

The first to third cell gaps $d1$ and $d3$, respectively, are determined in response to a liquid crystal of the liquid crystal layer **300**, an optical condition of the array substrate, or an optical condition of the color filter substrate **200**. In this exemplary embodiment, the second cell gap $d2$ corresponding to the reflection region is no more than about 1.7 μm , and the third cell gap $d3$ corresponding to the transmission region is no more than about 3.3 μm . The liquid crystal layer **300** may have a homogeneous alignment mode so that a twist angle of the liquid crystal layer **300** is about zero degrees.

In this exemplary embodiment, a lower alignment layer (not shown) of the array substrate **100** is rubbed in a first direction, and an upper alignment layer (also not shown) of the color filter substrate **200** is rubbed in a second direction that is substantially opposite to the first direction.

In this exemplary embodiment, voltages are applied to the pixel electrode **160** of the array substrate **100** and the common electrode **240** of the color filter substrate **200** forming an electric field that is applied to the liquid crystal layer **300**. In an alternative embodiment, the array substrate **100** may include both the pixel electrode **160** and the common electrode **240** in place of forming the common electrode **240** on the color filter substrate.

The lower film assembly **410** includes a lower $\lambda/4$ retardation film **412** and a lower polarizer **414**. The lower $\lambda/4$ retardation film **412** is disposed intermediate the array substrate **100** and the lower polarizer **414**. The lower polarizer **414** is disposed under the lower $\lambda/4$ retardation film **412** and defines a bottom of the LCD apparatus as illustrated in FIG. 8.

When a horizontally polarized light is incident on the lower $\lambda/4$ retardation film **412** from a top side of the LCD apparatus, a phase of the horizontally polarized light is delayed by about $1/4$ phase ($\lambda/4$) so that a right circularly polarized light is emitted from the lower $\lambda/4$ retardation film **412** toward the lower polarizer **414**. When the right circularly polarized light is incident on the lower retardation film **412** from a top side of the LCD apparatus, a phase of the right circularly polarized light is delayed by about $1/4$ phase ($\lambda/4$) so that the horizontally polarized light is emitted from the lower retardation film **412** toward the lower polarizer **414**.

The lower polarizer **414** includes a first polarizing axis allowing a light that is polarized in the first polarizing axis to pass through the lower polarizer **414** toward the lower $\lambda/4$ retardation film **412** or the backside. For example, when the first polarizing axis is substantially parallel with the horizontal direction defining each of the plurality of layers of the LCD apparatus, the horizontally polarized light passes through the lower polarizer **414** from the backside so that the horizontally polarized light is incident on the lower $\lambda/4$ retardation film **412**. In addition, the horizontally polarized light may pass through the lower polarizer **414** from the lower $\lambda/4$ retardation film **412** so that the horizontally polarized light is emitted from the lower polarizer **414** toward the backside.

The upper film assembly **420** is disposed on the color filter substrate **200** and includes an upper $\lambda/4$ retardation film **422**

and an upper polarizer **424**. The upper $\lambda/4$ retardation film **422** is disposed intermediate the upper polarizer **424** and the color filter substrate.

When a light from the color filter substrate **200** is incident on the upper $\lambda/4$ retardation film **422**, a phase of the light is delayed by about $1/4$ phase ($\lambda/4$) so that the light having the delayed phase is emitted from the upper $\lambda/4$ retardation film **422** toward a viewer's side. When a light is incident on the upper $\lambda/4$ retardation film **422** from the viewer's side, a phase of the light is delayed by about $1/4$ phase ($\lambda/4$) so that the light having the delayed phase is emitted from the upper $\lambda/4$ retardation film **422** toward color filter substrate **200**.

The upper polarizer **424** includes a second polarizing axis allowing a light that is polarized in the second polarizing axis to pass through the upper polarizer **424** toward the upper $\lambda/4$ retardation film **422** from the viewer's side. For example, when the second polarizing axis is substantially parallel with a vertical direction or normal to the layers defining the LCD apparatus, the vertically polarized light passes through the upper polarizer **424** from the viewer's side so that the vertically polarized light is incident on the upper $\lambda/4$ retardation film **422**. In addition, the vertically polarized light may pass through the upper polarizer **424** from the upper $\lambda/4$ retardation film **422** so that the vertically polarized light is emitted from the upper polarizer **424** toward the viewer's side.

In operation, when an artificial light generated from a lamp (not shown) is incident on the lower polarizer **414**, a linearly polarized light that is a P wave is emitted from the lower polarizer **414** toward the viewer's side. When the linearly polarized light is incident on the lower $\lambda/4$ retardation film **412**, an elliptically polarized light is emitted from the lower $\lambda/4$ retardation film **412** toward the viewer's side. When the elliptically polarized light is incident on the brightness enhancement layer **150**, a substantially linearly polarized light that is a S-wave is emitted from the brightness enhancement layer **150** toward the viewer's side. The substantially linearly polarized light is reflected and scattered from the reflection layer **170** toward the backside. The linearly polarized light may be diffused from the reflection layer **170**.

When the reflected light is incident on the brightness enhancement layer **150** from the viewer's side, the elliptically polarized light is emitted from the brightness enhancement layer **150** toward the backside. When the elliptically polarized light is incident on the lower $\lambda/4$ retardation film **412**, the linearly polarized light (the P-wave) is emitted from the lower $\lambda/4$ retardation film **412** through the lower polarizer **414** toward the backside.

The linearly polarized light that passes through the lower polarizer **414** is then reflected from a lamp reflecting plate **60** (see FIG. 2) so that the reflected light is emitted from the lamp reflecting plate (not shown) toward the reflection layer **170** and out through the transmission window corresponding with an absence of the reflection layer **170**. Therefore, a portion of the light generated from the lamp is recycled to improve a luminance of the LCD apparatus. In addition, a luminance of the LCD apparatus in a transmission mode is improved although a power consumption of the LCD apparatus need not be increased.

FIGS. 9A to 9E are cross-sectional views illustrating a method of manufacturing an array substrate **100** shown in FIG. 8.

Referring to FIG. 9A, a metal is deposited on the lower transparent plate **105**. The metal may include tantalum (Ta), titanium (Ti), molybdenum (Mo), aluminum (Al), chromium (Cr), copper (Cu), or tungsten (W), for example, but is not limited thereto. The lower transparent plate **105** includes an insulating material, such as glass, ceramic, quartz, for

example. The deposited metal is patterned to form a plurality of gate lines (not shown) and a plurality of the gate electrodes **110**. The gate lines (not shown) are extended in a longitudinal direction with respect to the lower transparent plate **105**, and aligned in a horizontal direction that is substantially perpendicular to the longitudinal direction. Each of the gate lines (not shown) is electrically connected to a portion of the gate electrodes **110** as recognized by those skilled in the pertinent art. A storage electrode (not shown) line may be formed together with the gate electrode **110**.

A silicon nitride is deposited over the lower transparent plate **105** having the gate electrode **110** using a plasma chemical vapor deposition to form the gate insulating layer **112**. An amorphous silicon layer is deposited on the gate insulating layer **112**, and an n+ amorphous silicon layer is formed by implanting impurities on the amorphous silicon layer in-situ. The n+ amorphous silicon layer and the amorphous silicon layer are patterned to form the semiconductor layer **114** and the ohmic contact layer **116** disposed on the semiconductor layer **114**.

A metal, for example, such as tantalum (Ta), titanium (Ti), molybdenum (Mo), aluminum (Al), chromium (Cr), copper (Cu), or tungsten (W), for example, is deposited on the gate insulating layer **112** having the semiconductor layer **114** and the ohmic contact layer **116**. The deposited metal is then patterned to form a plurality of source lines (not shown), a plurality of the source electrodes **120** and a plurality of the drain electrodes **130**. The source lines (not shown) are extended in the horizontal direction. Each of the source lines (not shown) is electrically connected to a portion of the source electrodes **120** as recognized by those skilled in the pertinent art. Each of the drain electrodes **130** is spaced apart from each of the source electrodes **120**. In an alternative embodiment, a passivation layer may be formed over the gate insulating layer **112** having the semiconductor layer **114**, the ohmic contact layer **116**, the source electrode **120** and the drain electrode **130**.

Referring to FIG. 9B, the organic insulating layer **140** is formed by coating a photoresist on the gate insulating layer **112** having the semiconductor layer **114**, the ohmic contact layer **116**, the source electrode **120**, and the drain electrode **130** through a spin coating process. Portions of the organic insulating layer **140** are removed to form the contact hole **141**, through which the drain electrode **130** is partially exposed, and the opening, through which the gate insulating layer **112** corresponding to the transmission window is exposed. The organic insulating layer **140** includes an acrylic resin and a positive photoresist. The contact hole **141** and the opening are formed through a photo process having an exposure step and a developing step. When an ultraviolet light is irradiated on a portion of the positive photoresist, the portion of the positive photoresist is removed during the developing step, and a remaining portion of the positive photoresist remains.

Referring to FIG. 9C, an ultraviolet curable liquid crystal polymer is coated and aligned on the organic insulating layer **140**. The ultraviolet curable liquid crystal polymer may be a cholesteric liquid crystal illustrated in FIG. 3. An ultraviolet light is irradiated on the aligned ultraviolet curable liquid crystal polymer to fix the ultraviolet curable liquid crystal, thereby forming the brightness enhancement layer **150**. In this exemplary embodiment, the brightness enhancement layer **150** has an uneven surface. The uneven surface may include an embossed pattern. The brightness enhancement layer **150** may be a biaxial film or a uniaxial film dependent on the polarization of the ultraviolet light irradiated thereon. When a polarized ultraviolet light is irradiated on the aligned ultraviolet curable liquid crystal polymer, the brightness

enhancement layer **150** has the uniaxial film. When a non-polarized ultraviolet light is irradiated on the aligned ultraviolet curable liquid crystal polymer, the brightness enhancement layer **150** may be a C-plate.

Referring to FIG. 9D, the pixel electrode **160** is illustrated as being formed on the lower transparent plate **105** via the brightness enhancement layer **150** corresponding to each of the pixel regions. The pixel electrode **160** may be formed through a patterning or a selective deposition.

Referring to FIG. 9E, the reflection layer **170** is illustrated as being formed on the lower transparent plate **105** via the pixel electrode **160** corresponding to the reflection region. In an alternative embodiment, the lower alignment layer (not shown) may be formed on the transparent plate **105** having the reflection layer **170**.

To complete manufacture of the LCD apparatus as illustrated in FIG. 8, the array substrate **100** is combined with the color filter substrate **200** with the liquid crystal layer **300** being formed between the array substrate **100** and the color filter substrate **200**.

FIGS. 10A to 10D are cross-sectional views illustrating brightness enhancement layers in accordance with other exemplary embodiments of the present invention. It will be recognized that the brightness enhancement layers of FIGS. 10A to 10D are defined with varying thicknesses or uneven surfaces along a length thereof.

Referring to FIG. 10A, the brightness enhancement layer is defined with a uniform thickness $d1$ along a length thereof, thus a scattering portion is absent therefrom. A reflection layer may be disposed on the brightness enhancement layer in this embodiment. A light path of the brightness enhancement layer is about $2 \times d1$, and an optical characteristic of the brightness enhancement layer is about $2 \times \Delta n d1$.

Referring to FIG. 10B, the brightness enhancement layer is defined with a plurality of convex and concave portions along a length thereof. Each of the convex portions has a first thickness $d1$, and each of the concave portions has a second thickness $d2$. In this embodiment, a reflection layer is disposed on the brightness enhancement layer.

A first light path of each of the convex portions is about $2 \times d1$, and a second light path of each of the concave portion is about $2 \times d2$. An optical characteristic of each of the convex portions is about $2 \times \Delta n d1$, while an optical characteristic of each of the concave portions is about $2 \times \Delta n d2$.

Referring to FIG. 10C, the brightness enhancement layer is defined with a plurality of convex portions and a plurality of concave portions along a length thereof. Thicknesses $d1$ and $d3$ of the convex portions are different from one another, as well as the thicknesses $d2$ and $d4$ of the concave portions. In this embodiment, a reflection layer is disposed on the brightness enhancement layer.

The convex portions provide various light paths of about $2 \times d1$ and $2 \times d3$, while the concave portions also provide various light paths of about $2 \times d2$ and $2 \times d4$, respectively. Optical characteristics of the convex portions are about $2 \times \Delta n d1$ and $2 \times \Delta n d3$, respectively, and optical characteristics of the concave portions are about $2 \times \Delta n d2$ and $2 \times \Delta n d4$, respectively.

Referring to FIG. 10D, the brightness enhancement layer is defined with a plurality of convex portions and a plurality of flat portions intermediate adjacent convex portions. Thicknesses $d1$ and $d4$ of the convex portions are different from one another, while each of the flat portions has a fifth thickness $d5$. In this embodiment, a reflection layer is disposed on the brightness enhancement layer.

The convex portions provide various light paths of about $2 \times d1$ and $2 \times d4$, while a light path of each of the flat portions

is about $2 \times d5$. Optical characteristics of the convex portions are about $2 \times \Delta n d1$ and $2 \times \Delta n d4$, respectively, and an optical characteristic of each of the flat portions is about $2 \times \Delta n d5$.

FIG. 11 is a cross-sectional view illustrating an LCD apparatus in accordance with another exemplary embodiment of the present invention. A brightness enhancement layer **550** is disposed intermediate a lower transparent plate **505** and a TFT of an array substrate **500**. The LCD apparatus of FIG. 11 is the same as in FIG. 8 except for the location of the brightness enhancement layer **550**. Thus, the same reference numerals will be used to refer to the same or like parts as those described in FIG. 8 and any further explanation will be omitted.

The LCD apparatus includes the array substrate **500**, a color filter substrate **200**, a liquid crystal layer **300** disposed between the array substrate **500** and the color filter substrate **200**, a lower film assembly **410** and an upper film assembly **420**. The lower film assembly **410** and the upper film assembly **420** define outboard layers of the LCD apparatus as illustrated.

The array substrate **500** includes, disposed in ascending order as illustrated, the lower transparent plate **505**, the brightness enhancement layer **550**, the TFT, an organic insulating layer **540**, a pixel electrode **511**, and a reflection layer **570**. The brightness enhancement layer **550** is disposed on the lower transparent plate **505** and below a gate insulating layer **512** formed on an opposite surface defining the lower transparent plate **505**. The TFT includes a gate electrode **510** formed on the lower transparent plate **505**, the gate insulating layer **512** formed on the lower transparent plate **505**, a semiconductor layer **514**, an ohmic contact layer **516**, a source electrode **520**, and a drain electrode **530**. The organic insulating layer **540** is disposed over the TFT. The drain electrode **530** and the gate insulating layer **512** correspond to a reflection region and are partially exposed through a contact hole **541** and an opening of the organic insulating layer **540**, respectively.

The lower transparent plate **505** includes the reflection region and a transmission window. The brightness enhancement layer **550** is disposed on the lower transparent plate **505** corresponding to the reflection region. In this exemplary embodiment, the brightness enhancement layer **550** is defined having an uneven surface facing the lower transparent plate **505**. Convex and concave portions may be formed on the brightness enhancement layer **550** defining the uneven thickness. Therefore, when a light that has passed through the brightness enhancement layer **550** is reflected from the reflection layer **570** and passes through the brightness enhancement layer **550** toward a backside of the LCD apparatus (e.g., toward the lower film assembly **410**), the light passes through various light paths corresponding to the uneven surface defining the brightness enhancement layer **550** having various optical characteristics $\Delta n d$.

The pixel electrode **560** is formed over the gate insulating layer **512** that is exposed through the opening of the brightness enhancement layer **550**, the organic insulating layer **540** and the contact hole **541** so that the pixel electrode **560** is electrically connected to the drain electrode **530** of the TFT. The reflection layer **570** is formed on the pixel electrode **560** and corresponds to the reflection region. A transmission window is defined by the absence of the reflection layer **570** on the pixel electrode **560**. A capacitor line is optionally be formed intermediate the organic insulating layer **540** and the pixel electrode **560** in a region spaced apart from the TFT so that the capacitor line and a portion of the pixel electrode **560** form a storage capacitor C_{sr} . In the exemplary embodiment of FIG. 11, the reflection layer **570** is formed on the pixel elec-

trode **511**, alternatively, an insulating layer may be disposed between the reflection layer **570** and the pixel electrode **560**.

Therefore, a portion of the light generated from a lamp (not shown) is recycled to improve a luminance of the LCD apparatus. Furthermore, since the light from the lamp may not be incident on the TFT that partially absorbs the light, a luminance of a transmission mode of the LCD apparatus is improved.

FIG. **12** is a cross-sectional view illustrating an LCD apparatus in accordance with another exemplary embodiment of the present invention. In this embodiment, a brightness enhancement layer **650** is formed on a TFT. The LCD apparatus of FIG. **12** is the same as in FIG. **8** except for the location of the brightness enhancement layer **650**. Thus, the same reference numerals will be used to refer to the same or like parts as those described in FIG. **8** and any further explanation will be omitted.

The LCD apparatus includes an array substrate **600**, a color filter substrate **200**, a liquid crystal layer **300** disposed intermediate the array substrate **600** and the color filter substrate **200**, a lower film assembly **410**, and an upper film assembly **420**. The lower film assembly **410** and the upper film assembly **420** define outboard layers of the LCD apparatus as illustrated.

The array substrate **600** includes, disposed in ascending order as illustrated, a lower transparent plate **605**, a TFT, the brightness enhancement layer **650**, an organic insulating layer **640**, a pixel electrode **611**, and a reflection layer **670**. The TFT includes a gate electrode **610** formed on the lower transparent plate **605**, a gate insulating layer **612** formed on the lower transparent plate **605** having the gate electrode **610**, a semiconductor layer **614**, an ohmic contact layer **616**, a source electrode **620**, and a drain electrode **630**. In this embodiment, it will be recognized that the brightness enhancement layer **650** is disposed on the TFT. Further, the organic insulating layer **640** is disposed over the gate insulating layer **612** having the brightness enhancement layer **650** thereon. The drain electrode **630** and the gate insulating layer **612** corresponding to a reflection region and a transmission window are partially exposed through a contact hole **641** and an opening of the organic insulating layer **640**, respectively. The contact hole **641** and the opening are formed in the organic insulating layer **640** and the brightness enhancement layer **650**.

The lower transparent plate **605** includes the reflection region and a transmission window. The brightness enhancement layer **650** is disposed on the source electrode **620**, the drain electrode **630**, the gate insulating layer **612**, the semiconductor layer **614**, and the lower transparent plate **605** corresponding to the reflection region. In this exemplary embodiment, the brightness enhancement layer **650** is defined with an uneven surface facing the organic insulating layer **640**. The uneven thickness may be defined by convex and concave portions along a length of the brightness enhancement layer **650**. Therefore, when a light that has passed through the brightness enhancement layer **650** is reflected from the reflection layer **670** and passes through the brightness enhancement layer **650** toward a backside of the LCD apparatus (e.g., toward the lower film assembly **410**), the light passes through various light paths corresponding to the uneven brightness enhancement layer **650** having various optical characteristics Δn_d .

The pixel electrode **660** is formed over the gate insulating layer **612** that is exposed through the opening of the brightness enhancement layer **650**, the organic insulating layer **640**, and the contact hole **641** so that the pixel electrode **660** is electrically connected to the drain electrode **630** of the TFT.

The reflection layer **670** is formed on the pixel electrode **660** corresponding to the reflection region. A transmission window is defined by the absence of the reflection layer **670** on the pixel electrode **660**. A capacitor line is optionally formed intermediate the organic insulating layer **640** and the pixel electrode **660** in a region spaced apart from the TFT so that the capacitor line and a portion of the pixel electrode **660** may form a storage capacitor C_{st} . It will be recognized that in this exemplary embodiment, the reflection layer **670** is formed on the pixel electrode **660**. Alternatively, an insulating layer may be disposed between the reflection layer **670** and the pixel electrode **660**.

FIG. **13** is a cross-sectional view illustrating an LCD apparatus in accordance with another exemplary embodiment of the present invention. In this embodiment, a brightness enhancement layer **710** is formed under a color filter **730**.

The LCD apparatus includes a color filter substrate **700**, an array substrate **800**, a liquid crystal layer **300** disposed intermediate the array substrate **800** and the color filter substrate **700**, a lower film assembly **410** and an upper film assembly **420**. The lower film assembly **410** and the upper film assembly **420** define outboard layers of the LCD apparatus as illustrated, while the color filter substrate **700** is disposed under the array substrate **800** and intermediate the liquid crystal layer **300** and the lower film assembly **410**.

The color filter substrate **700** includes, disposed in ascending order as illustrated in FIG. **13**, a lower transparent plate **705**, a brightness enhancement layer **710**, a reflection layer **720**, a color filter **730**, a surface protection layer **740** and a common electrode **750**. The brightness enhancement layer **710** is disposed on the reflection layer **720** corresponding to the reflection region. The color filter **730** includes a red color filter portion, a green color filter portion and a blue color filter portion. The red color filter portion is disposed in a red pixel region, the green color filter portion is disposed in a green pixel region, and the blue color filter portion is disposed in a blue pixel region. The surface protection layer **740** is disposed on the lower transparent plate **705** having the brightness enhancement layer **710** and the reflection layer **720**. In this exemplary embodiment, the brightness enhancement layer **710** is defined with an uneven surface. The uneven surface may be defined by convex and concave portions formed along a length of the brightness enhancement layer **710**. In this embodiment, as illustrated, convex and concave portions of the brightness enhancement layer face the reflection layer **720**.

The lower transparent plate **705** includes the reflection region and a transmission window. The reflection layer **720** corresponds to the reflection region, while a transmission window is defined by an absence of the reflection layer **720** and on the lower transparent plate **705**.

When a light that has passed through the brightness enhancement layer **710** is reflected from the reflection layer **720** and passes through the brightness enhancement layer **710** toward a backside of the LCD apparatus (e.g., toward the lower film assembly **410**), the light passes through various light paths corresponding to the uneven brightness enhancement layer **710** having various optical characteristics Δn_d .

The array substrate **800** includes, disposed in descending order as illustrated in FIG. **13**, an upper transparent plate **805**, a TFT, an organic insulating layer **840**, and a pixel electrode **850**. The TFT includes a gate electrode **810** disposed under the upper transparent plate **805**, a gate insulating layer **812** disposed under the upper transparent plate **805** having the gate electrode **810**, a semiconductor layer **814**, an ohmic contact layer **816**, a source electrode **820**, and a drain electrode **830**. The organic insulating layer **840** is disposed under

the upper transparent plate **805** having the TFT. The drain electrode **830** is partially exposed through a contact hole **841**.

The pixel electrode **850** is formed intermediate the organic insulating layer **840** and the liquid crystal layer **300**. In particular, the pixel electrode **850** is formed under the organic insulating layer **840** and the contact hole **841** allowing the pixel electrode **850** to be electrically connected to the drain electrode **830** of the TFT.

The pixel electrode **850** is a transparent electrode that includes indium tin oxide (ITO), tin oxide (TO), indium zinc oxide (IZO), and zinc oxide (ZO), for example, but is not limited thereto. A capacitor line is optionally formed intermediate the organic insulating layer **840** and the pixel electrode **850** in a region spaced apart from the TFT so that the capacitor line and a portion of the pixel electrode **850** may form a storage capacitor C_{st} .

The liquid crystal layer **300** is disposed between the array substrate **800** and the color filter substrate **700** to vary an arrangement of the liquid crystal in response to an electric field applied to the liquid crystal layer **300**. The electric field is formed by a voltage difference between the pixel electrode **850** of the array substrate **800** and the common electrode **750** of the color filter substrate **700**. Therefore, a front light that has passed through the array substrate **800** or a backside light that has passed through the transmission window defined by the reflection layer **720** is dependent on the electric field formed by a voltage difference between the pixel electrode **850** and the common electrode **750**.

A portion of the liquid crystal layer **300** corresponding to a contact hole **841** in the reflection region, a portion of the liquid crystal layer **300** corresponding to a remaining region of the reflection region, and a portion of the liquid crystal layer **300** corresponding to the transmission window have different cell gaps relative to one another. As described above, the pixel electrode **850** is electrically connected to the drain electrode **830** of the TFT through the contact hole **841**. A first cell gap **d1** of the liquid crystal layer **300** corresponding to the contact hole **841** is larger than a second cell gap **d2** of the liquid crystal layer **300** corresponding to the remaining region of the reflection region. A third cell gap **d3** of the liquid crystal layer **300** corresponding to the transmission window is less than the first cell gap **d1** of the liquid crystal layer **300** corresponding to the contact hole **841** but is greater than the second cell gap **d2** of the liquid crystal layer **300** corresponding to the remaining region of the reflection region.

An optical characteristic $\Delta n d_1$ of the liquid crystal layer **300** corresponding to the contact hole **841** is substantially equal to an anisotropy of a reflective index Δn multiplied by the first cell gap **d1**. Likewise, optical characteristics $\Delta n d_2$ and $\Delta n d_3$ of the liquid crystal layer **300** corresponding to the remaining region of the reflection region and the transmission region are substantially equal to the anisotropy of the reflective index Δn multiplied by the second cell gap **d2** and the third cell gap **d3**, respectively. The surface protection layer **730** is defined having a stepped portion corresponding to an interface between the reflection region and the transmission window so that a height of the color filter substrate **700** corresponding to the reflection region is larger than a height of the color filter substrate **700** corresponding to the transmission window. This feature is also exemplified by cell gap **d3** being larger than cell gap **d2** in FIG. 13.

The first, second and third cell gaps are determined in response to a liquid crystal of the liquid crystal layer **300**, an optical condition of the array substrate, or an optical condition of the color filter substrate. In this exemplary embodiment, the second cell gap **d2** corresponding to the reflection

region is no more than about 1.7 μm , while the third cell gap **d3** corresponding to the transmission region is no more than about 3.3 μm .

The liquid crystal layer **300** may have a homogeneous alignment mode so that a twist angle of the liquid crystal layer **300** is about zero degrees.

In this exemplary embodiment, an upper alignment layer (not shown) of the array substrate **800** is rubbed in a first direction, and a lower alignment layer (not shown) of the color filter substrate **700** is rubbed in a second direction substantially opposite to the first direction.

In this exemplary embodiment, when a voltage is applied to the pixel electrode **850** of the array substrate **800** and the common electrode **750** of the color filter substrate **700**, the electric field formed by the voltage is applied to the liquid crystal layer **300**. In an alternative embodiment, the array substrate **800** may include the pixel electrode **850** and the common electrode **750**.

The lower film assembly **410** includes a lower $\lambda/4$ retardation film **412** and a lower polarizer **414**. The lower $\lambda/4$ retardation film **412** is disposed under the array substrate **800** and intermediate the lower transparent plate **705** and the lower polarizer **414**, as illustrated in FIG. 13. The lower polarizer **414** is disposed under the lower $\lambda/4$ retardation film **412** and defines the backside of the LCD apparatus.

When a horizontally polarized light is incident on the lower $\lambda/4$ retardation film **412**, a phase of the horizontally polarized light is delayed by about $1/4$ phase ($\lambda/4$) so that a right circularly polarized light is emitted from the lower $\lambda/4$ retardation film **412** toward the lower polarizer **414**. When the right circularly polarized light is incident on the lower retardation film **412**, a phase of the right circularly polarized light is delayed by about $1/4$ phase ($\lambda/4$) so that the horizontally polarized light is emitted from the lower retardation film **412** toward the lower polarizer **414**.

The lower polarizer **414** includes a first polarizing axis allowing a light that is polarized in the first polarizing axis to pass through the lower polarizer **414** toward the lower $\lambda/4$ retardation film **412** or the backside of the LCD apparatus. For example, when the first polarizing axis is substantially parallel with the horizontal direction relative to the LCD apparatus having layers extending in the same direction, the horizontally polarized light passes through the lower polarizer **414** from the backside so that the horizontally polarized light is incident on the lower $\lambda/4$ retardation film **412**. In addition, the horizontally polarized light may pass through the lower polarizer **414** from the lower $\lambda/4$ retardation film **412** allowing the horizontally polarized light to be emitted from the lower polarizer **414** toward the backside.

The upper film assembly **420** includes an upper $\lambda/4$ retardation film **422** and an upper polarizer **424**. The upper $\lambda/4$ retardation film **422** is disposed on the upper transparent plate **805** of the array substrate **800**. The upper polarizer **424** is disposed on the upper $\lambda/4$ retardation film **422**, which is intermediate the upper $\lambda/4$ retardation film **422** and the upper $\lambda/4$ retardation film **422**.

When a light is incident on the upper $\lambda/4$ retardation film **422** from the array substrate **800**, a phase of the wavelength of the light is delayed by about $1/4$ phase ($\lambda/4$) so that the light having the delayed phase is emitted from the upper $\lambda/4$ retardation film **422** toward the upper $\lambda/4$ retardation film **422** corresponding to a viewer's side. When a light is incident on the upper $\lambda/4$ retardation film **422** from the viewer's side, a phase of the light is delayed by about $1/4$ phase ($\lambda/4$) so that the light having the delayed phase is emitted from the upper $\lambda/4$ retardation film **422** toward the array substrate **800**.

The upper polarizer **424** includes a second polarizing axis allowing a light that is polarized in the second polarizing axis to pass through the upper polarizer **424** toward the upper $\lambda/4$ retardation film **422** from the viewer's side. For example, when the second polarizing axis is substantially parallel with a vertical direction relative to stacking layers defining the LCD apparatus, the vertically polarized light passes through the upper polarizer **424** from the viewer's side allowing the vertically polarized light to be incident on the upper $\lambda/4$ retardation film **422**. In addition, the vertically polarized light may pass through the upper polarizer **424** from the upper $\lambda/4$ retardation film **422** allowing the vertically polarized light to be emitted from the upper polarizer **424** toward the viewer's side.

FIG. **14** is a cross-sectional view illustrating an LCD apparatus in accordance with another exemplary embodiment of the present invention. In this embodiment, a brightness enhancement layer **180** is disposed under a lower transparent plate **105** corresponding to a reflection region. The LCD apparatus of FIG. **14** is the same as in FIG. **8** except for the location of the brightness enhancement layer **180**. Thus, the same reference numerals will be used to refer to the same or like parts as those described in FIG. **8** and any further explanation will be omitted.

The LCD apparatus includes an array substrate **100**, a color filter substrate **200**, a liquid crystal layer **300** disposed intermediate the array substrate **100** and the color filter substrate **200**, a lower film assembly **410** and an upper film assembly **420**. The lower film assembly **410** and the upper film assembly **420** define outboard layers of the LCD apparatus as illustrated.

The brightness enhancement layer **180** is disposed under the array substrate **100** and disposed intermediate the lower transparent plate **105** and the lower film assembly **410**, as illustrated. In this exemplary embodiment, the brightness enhancement layer **180** is integrally formed under the array substrate **100**. Alternatively, the brightness enhancement layer **180** may be integrally formed on the lower film assembly **410**. The brightness enhancement layer **180** is defined having an uneven thickness. The uneven thickness may include convex and concave portions formed on the brightness enhancement layer **180**. In the embodiment illustrated in FIG. **14**, convex and concave portions define a surface of the brightness enhancement layer **180** facing the lower film assembly **410** along a length thereof. Therefore, when a light that has passed through the brightness enhancement layer **180** is reflected from a reflection layer **170** and passes through the brightness enhancement layer **180** toward a backside of the LCD apparatus, the light passes through various light paths corresponding to the uneven brightness enhancement layer **180** having various optical characteristics Δn_d .

Therefore, a portion of the light generated from a lamp (not shown) is recycled to improve a luminance of the LCD apparatus. In addition, the light may not be incident on the TFT that partially absorbs the light so that a luminance of the LCD apparatus in a transmission mode is improved.

According to the present invention, a brightness enhancement layer is formed corresponding to a reflection region of an array substrate so that at least a portion of light generated from a lamp is recycled. More specifically, the brightness enhancement layer allows a portion of the light that is reflected from a reflection layer to be recycled to improve a luminance of an LCD apparatus. Furthermore, the addition of the brightness enhancement layer allows a decrease in power consumption of the LCD apparatus.

While this invention has been described with reference to the exemplary embodiments disclosed herein, it is evident,

however, that many alternative modifications and variations will be apparent to those having skill in the art in light of the foregoing description. Accordingly, the present invention embraces all such alternative modifications and variations falling within the spirit and scope of the appended claims.

What is claimed is:

1. A transmissive and reflective type LCD comprising:

a first substrate;
a reflection layer disposed on the first substrate;
a second substrate having an inner surface that is arranged so as to face the first substrate;
a liquid crystal layer formed between the first substrate and the second substrate;
a first polarizing plate formed on an outer surface of the first substrate;
a backlight arranged at a rear side of the first polarizing plate;
a brightness enhancement layer located between the backlight and the reflection layer, and
wherein the brightness enhancement layer delays a phase of the light that has passed through the brightness enhancement layer by about $\lambda/4$.

2. The transmissive and reflective type LCD of claim 1, further comprising an second retardation film disposed between the first substrate and the liquid crystal layer.

3. The transmissive and reflective type LCD of claim 2, wherein the LCD includes at one least of pixel portion and the pixel portion is divided into a transmissive portion and a reflective portion.

4. The transmissive and reflective type LCD of claim 3, wherein a cell-gap of the transmissive portion is different from that of the reflective portion.

5. The transmissive and reflective type LCD of claim 4, wherein at least one surface of the brightness enhancement layer is defined by concave and convex portions.

6. The transmissive and reflective type LCD of claim 3, wherein at least one surface of the brightness enhancement layer is defined by concave and convex portions.

7. The transmissive and reflective type LCD of claim 2, wherein the LCD includes at one least of pixel portion and the pixel portion is divided into a transmissive portion and a reflective portion,

wherein a cell-gap of the transmissive portion is different from that of the reflective portion.

8. The transmissive and reflective type LCD of claim 7, wherein at least one surface of the brightness enhancement layer is defined by concave and convex portions.

9. The transmissive and reflective type LCD of claim 2, wherein at least one surface of the brightness enhancement layer is defined by concave and convex portions.

10. The transmissive and reflective type LCD of claim 1, wherein the LCD includes at one least of pixel portion and the pixel portion is divided into a transmissive portion and a reflective portion.

11. The transmissive and reflective type LCD of claim 10, wherein a cell-gap of the transmissive portion is different from that of the reflective portion.

12. The transmissive and reflective type LCD of claim 11, wherein at least one surface of the brightness enhancement layer is defined by concave and convex portions.

13. The transmissive and reflective type LCD of claim 10, wherein at least one surface of the brightness enhancement layer is defined by concave and convex portions.

14. The transmissive and reflective type LCD of claim 1, wherein the LCD includes at one least of pixel portion and the pixel portion is divided into a transmissive portion and a reflective portion,

25

wherein a cell-gap of the transmissive portion is different from that of the reflective portion.

15. The transmissive and reflective type LCD of claim 14, wherein at least one surface of the brightness enhancement layer is defined by concave and convex portions.

16. The transmissive and reflective type LCD of claim 1, wherein at least one surface of the brightness enhancement layer is defined by concave and convex portions.

17. The transmissive and reflective type LCD of claim 2, wherein the second retardation film delays a phase of light passing through the liquid crystal layer by about $\lambda/4$.

26

18. The transmissive and reflective type LCD of claim 1, wherein the brightness enhancement layer includes a cholesteric liquid crystal.

19. The transmissive and reflective type LCD of claim 15, wherein each of the concave portions of the first surface of the brightness enhancement layer is defined with a substantially flat section, and each of the convex portions of the first surface of the brightness enhancement layer is defined with a rounded section.

* * * * *

专利名称(译)	用于透射和反射型液晶显示器的相位延迟元件		
公开(公告)号	US7656480	公开(公告)日	2010-02-02
申请号	US11/184436	申请日	2005-07-19
[标]申请(专利权)人(译)	平井AKIRA 云锦HYUK UH KEE HAN PARK民秀		
申请(专利权)人(译)	平井AKIRA 云锦赫 KEE UH-HAN 朴民洙		
当前申请(专利权)人(译)	三星DISPLAY CO. , LTD.		
[标]发明人	HIRAI AKIRA YUN JIN HYUK UH KEE HAN PARK MIN SOO		
发明人	HIRAI, AKIRA YUN, JIN-HYUK UH, KEE-HAN PARK, MIN-SOO		
IPC分类号	G02F1/1335		
CPC分类号	G02F1/13363 G02F1/133526 G02F2001/133638 G02F2413/02		
代理机构(译)	康托科尔伯恩LLP		
优先权	1020040055827 2004-07-19 KR		
其他公开文献	US20060012737A1		
外部链接	Espacenet USPTO		

摘要(译)

相位延迟元件包括在反射层和人造光中间的亮度增强层。亮度增强层由第一表面和相对的第二表面限定。第一表面面向反射层。来自人造光的第一光入射在第二表面上。第一光的相位延迟大约1/4相位 ($\lambda/4$)，使得第二光从第一表面朝向反射层发射。第二光从反射层反射，使得第三光从反射层朝向第一表面发射。第三光的相位延迟大约1/4相位 ($\lambda/4$)，从而从第二表面发射第四光。因此，从反射层反射的一部分人造光被再循环以改善LCD装置的亮度。

