



US 20070040971A1

(19) **United States**

(12) **Patent Application Publication**
Maekawa et al.

(10) **Pub. No.: US 2007/0040971 A1**

(43) **Pub. Date: Feb. 22, 2007**

(54) **LIQUID CRYSTAL DISPLAY DEVICE AND MANUFACTURING METHOD THEREOF**

Publication Classification

(76) Inventors: **Shinji Maekawa**, Shizuoka (JP);
Shunpei Yamazaki, Tokyo (JP);
Hideaki Kuwabara, Kanagawa (JP);
Yoshitaka Moriya, Kanagawa (JP)

(51) **Int. Cl.**
G02F 1/1333 (2006.01)
G02F 1/136 (2006.01)
(52) **U.S. Cl.** **349/122; 349/43**

Correspondence Address:
NIXON PEABODY, LLP
401 9TH STREET, NW
SUITE 900
WASHINGTON, DC 20004-2128 (US)

(57) **ABSTRACT**

By using one photo mask in the manufacturing steps of a liquid crystal display device, steps such as resist coating, prebaking, exposure, development, and postbaking, as well as the formation of a covering film, etching, resist peeling, rinsing, drying and the like before and after the aforementioned steps are required, which make the process complicated. To solve the problem, a channel-etch type bottom gate TFT (inverted staggered TFT) is employed to pattern source and drain regions and a pixel electrode with the same mask. Moreover, according to the invention, among the patterns required to form a liquid crystal display device such as a conductive layer for a wiring layer or an electrode, a mask for forming a predetermined pattern and the like, at least one or more of them is formed by a method by which a pattern can selectively be formed, thereby manufacturing a liquid crystal display device.

(21) Appl. No.: **10/577,058**

(22) PCT Filed: **Nov. 5, 2004**

(86) PCT No.: **PCT/JP04/16782**

§ 371(c)(1),
(2), (4) Date: **Apr. 24, 2006**

(30) **Foreign Application Priority Data**

Nov. 14, 2003 (JP) 2003-386013

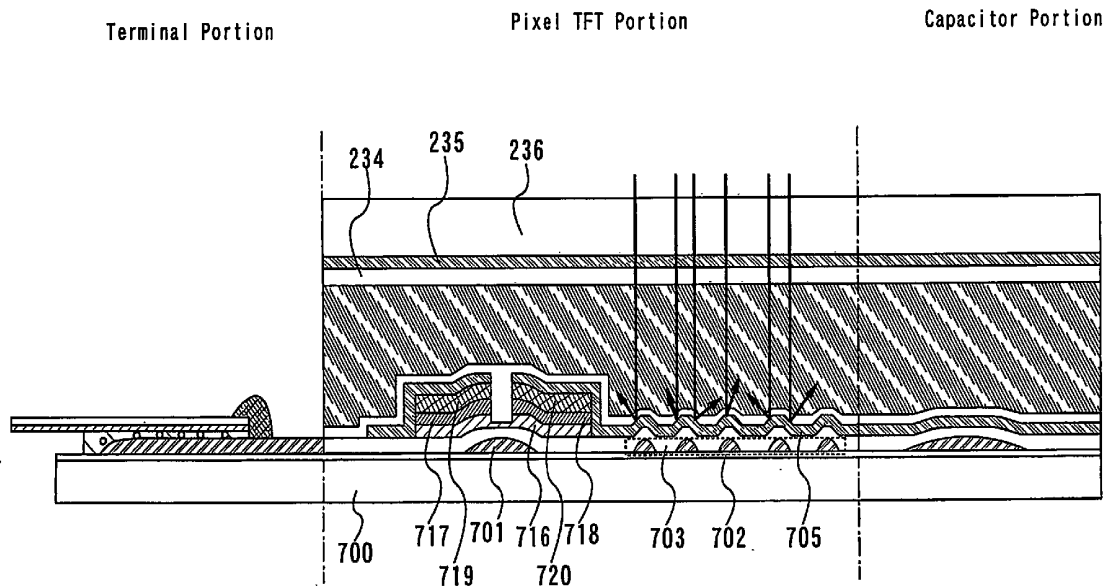

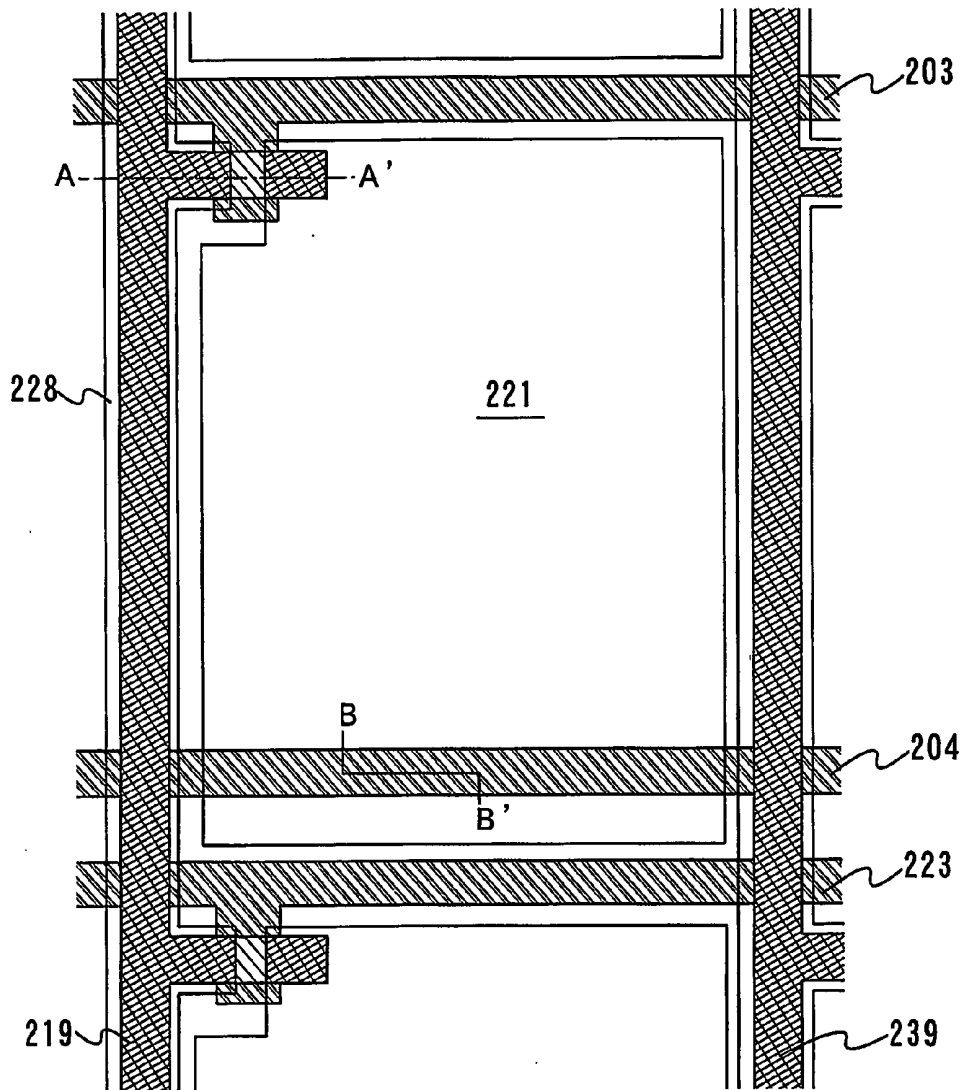

FIG. 1

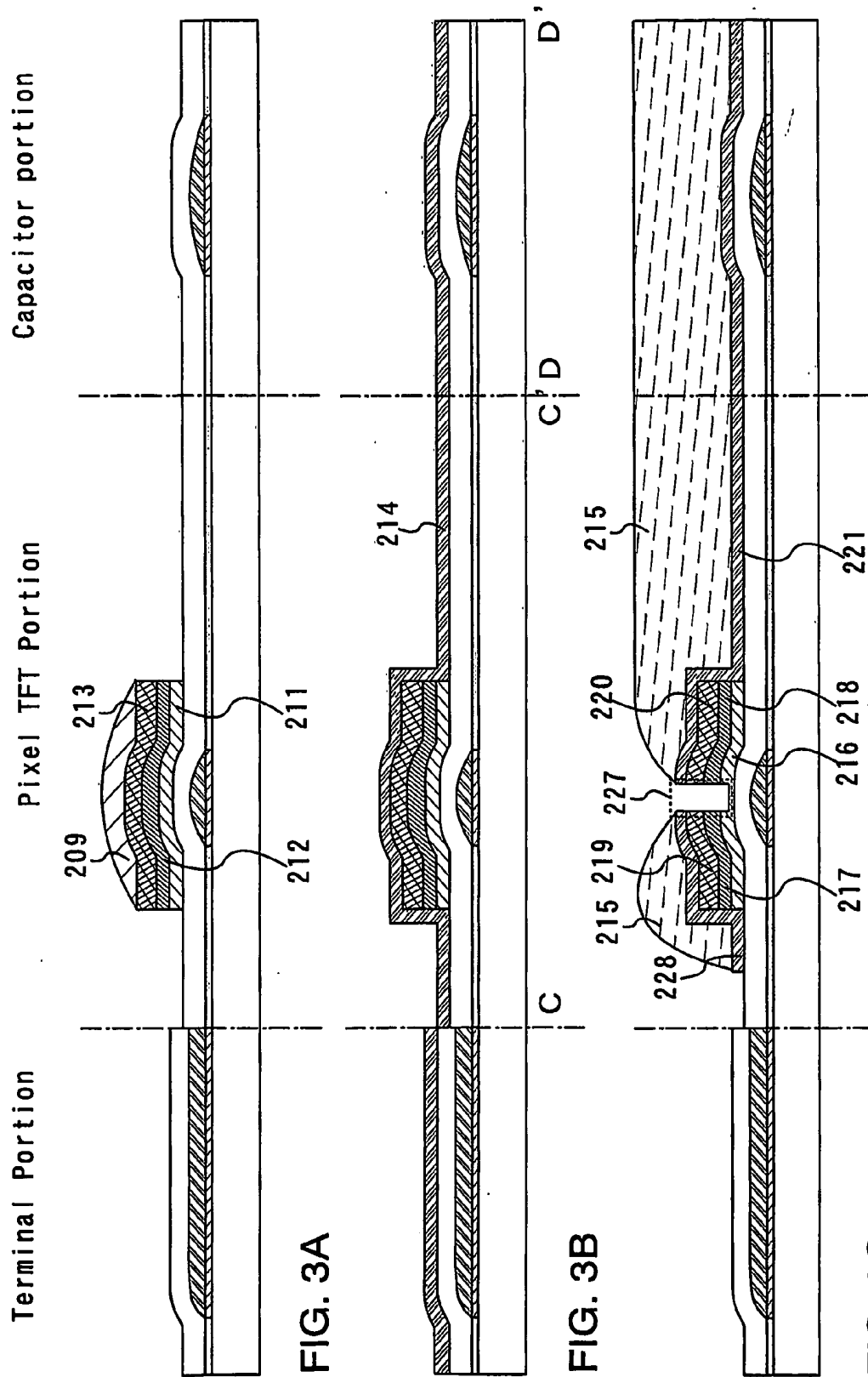

FIG. 3A

FIG. 3B

FIG. 3C

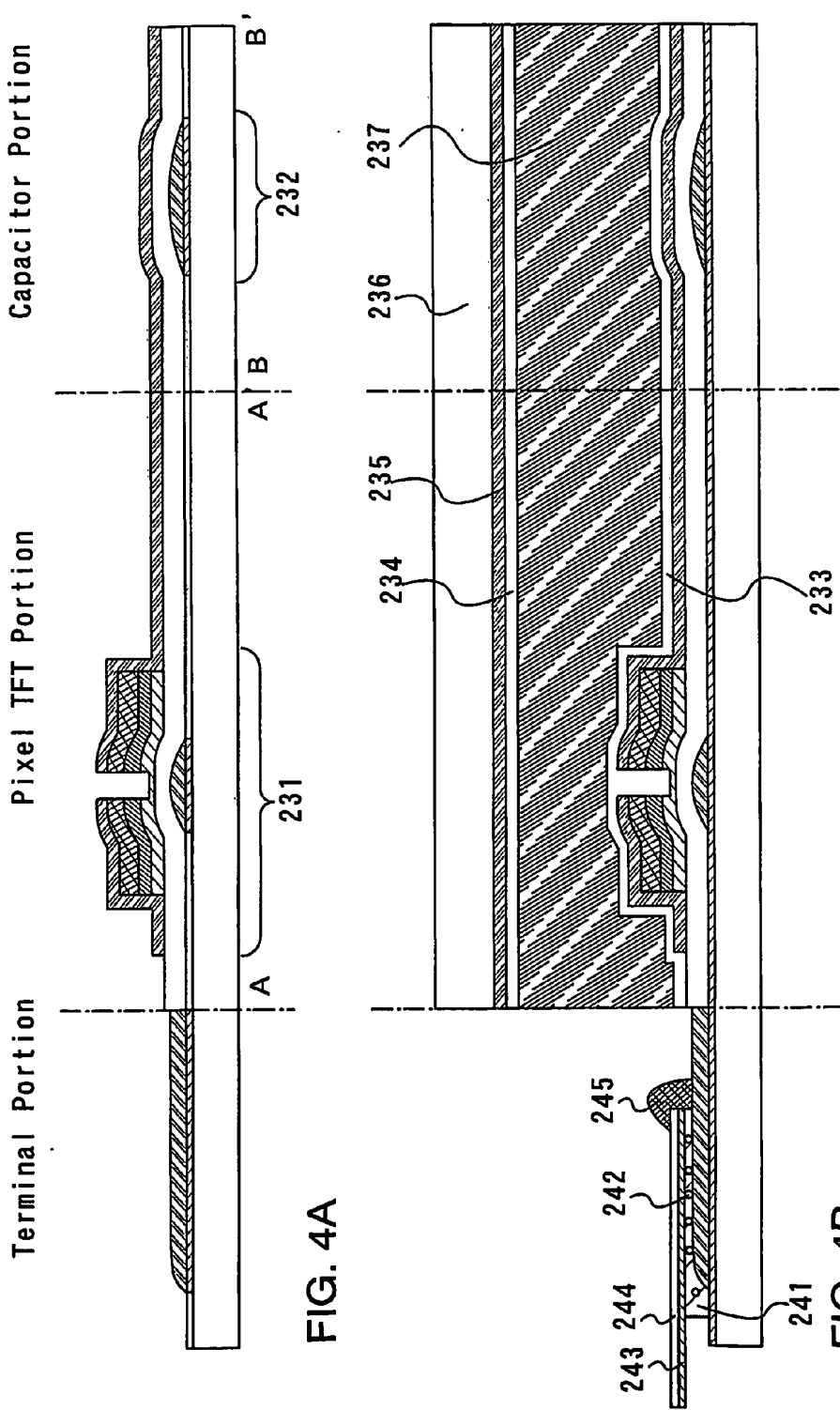

FIG. 4A

FIG. 4B

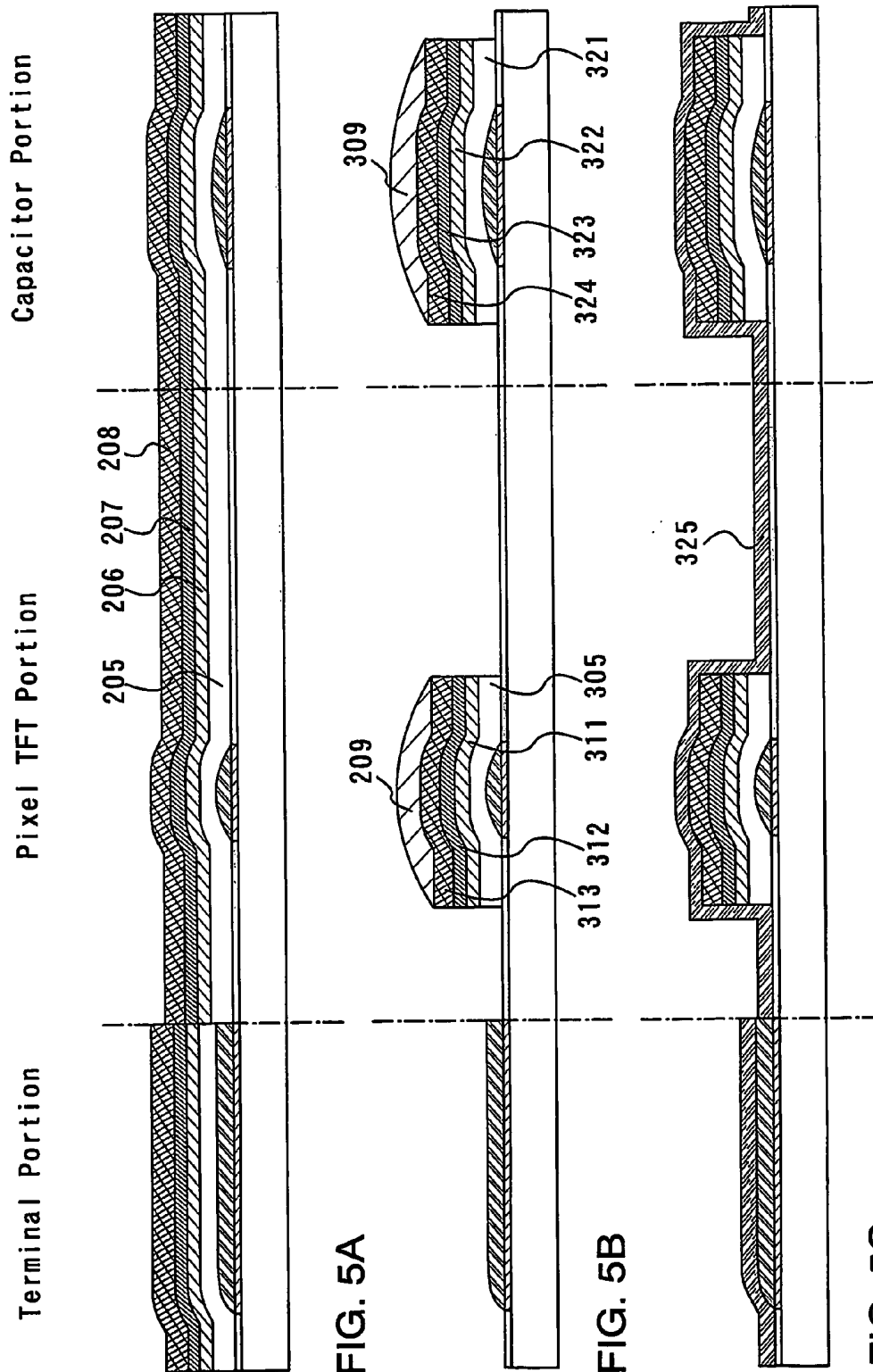

FIG. 5A

FIG. 5B

FIG. 5C

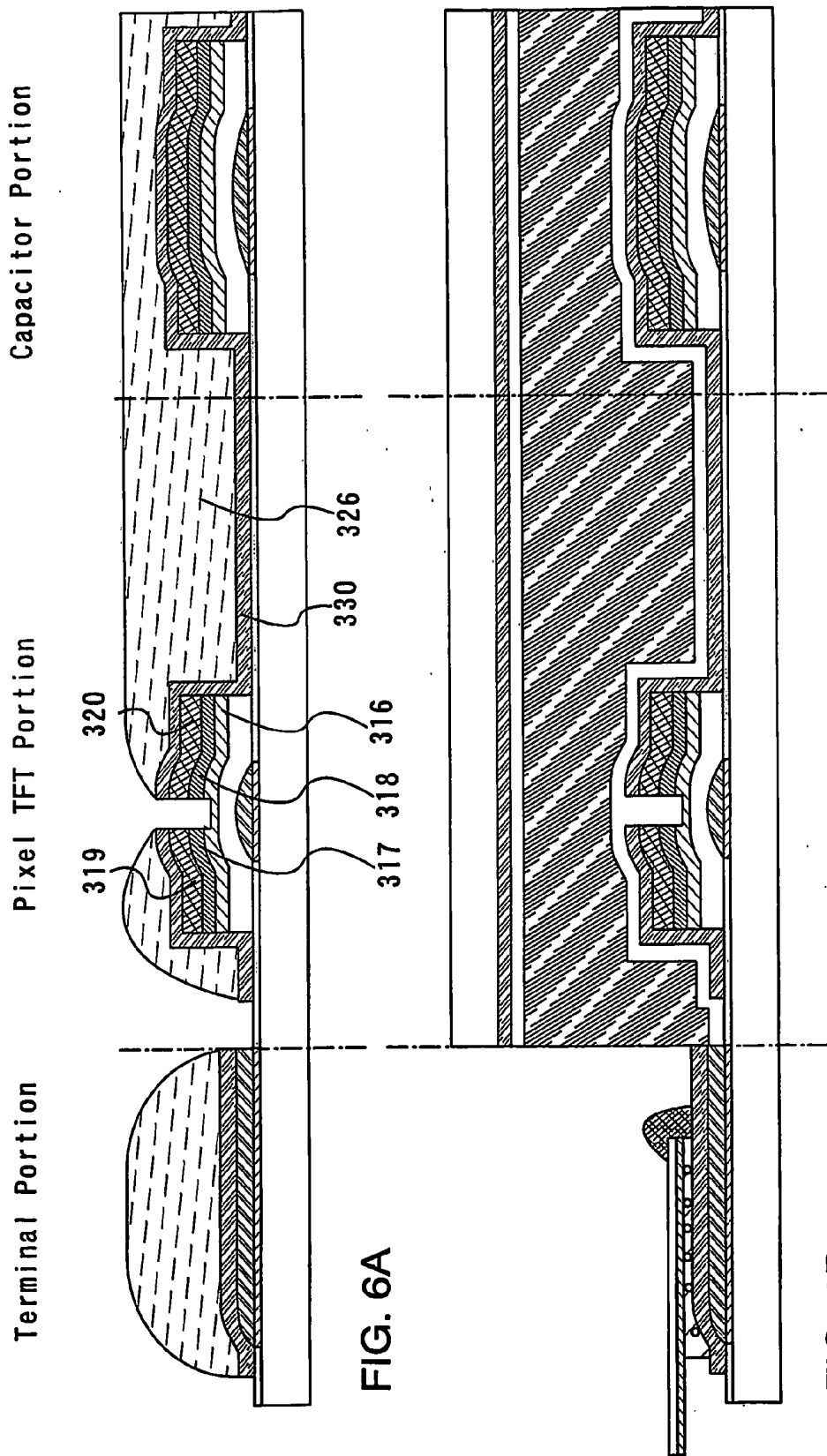

FIG. 6A

FIG. 6B

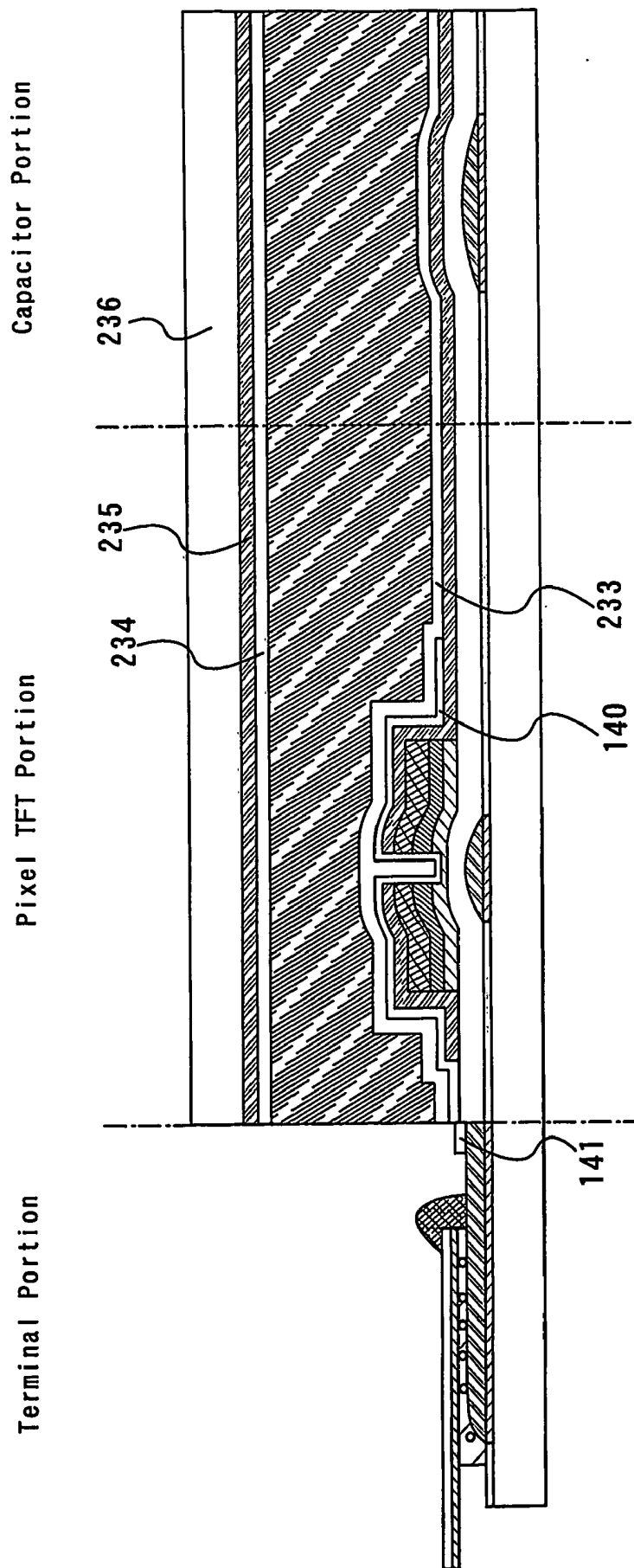

FIG. 7

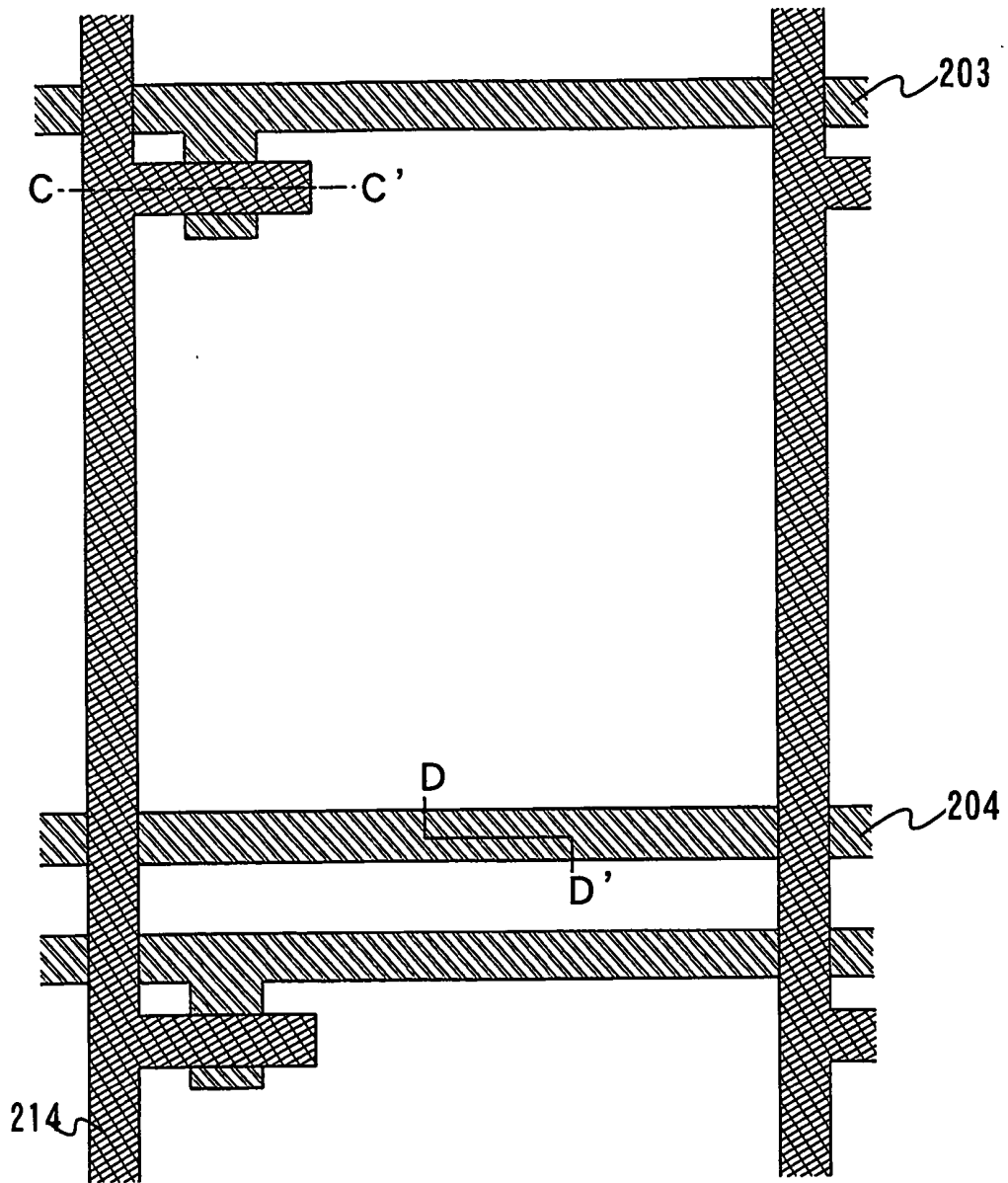

FIG. 8

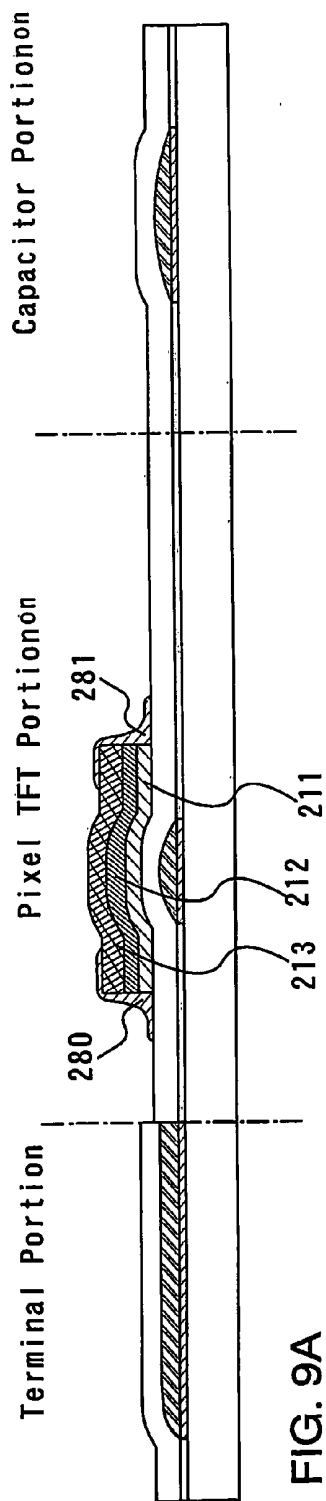

FIG. 9A

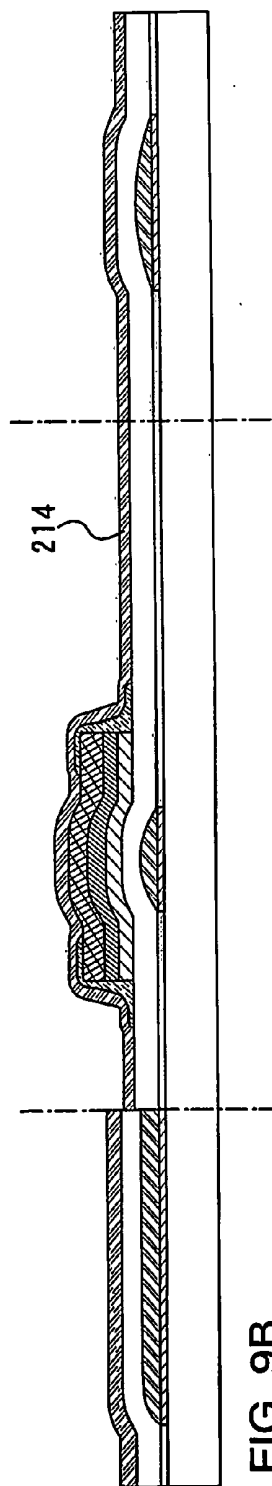

FIG. 9B

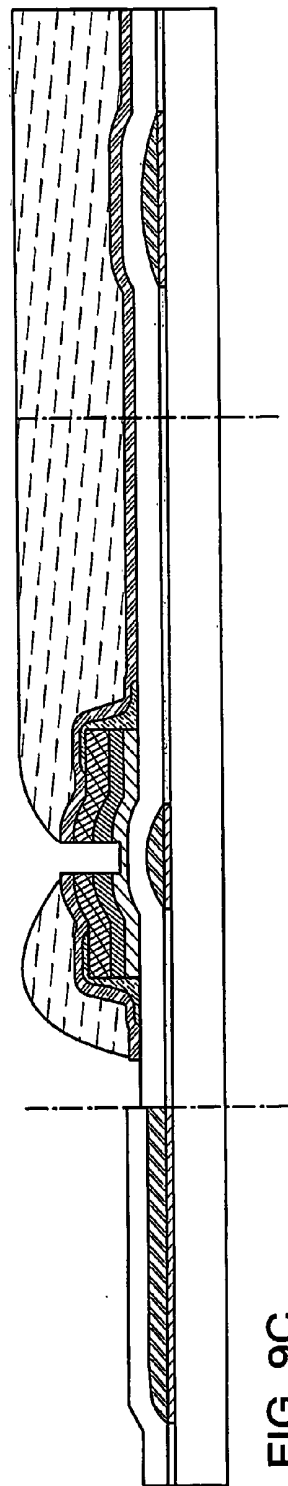

FIG. 9C

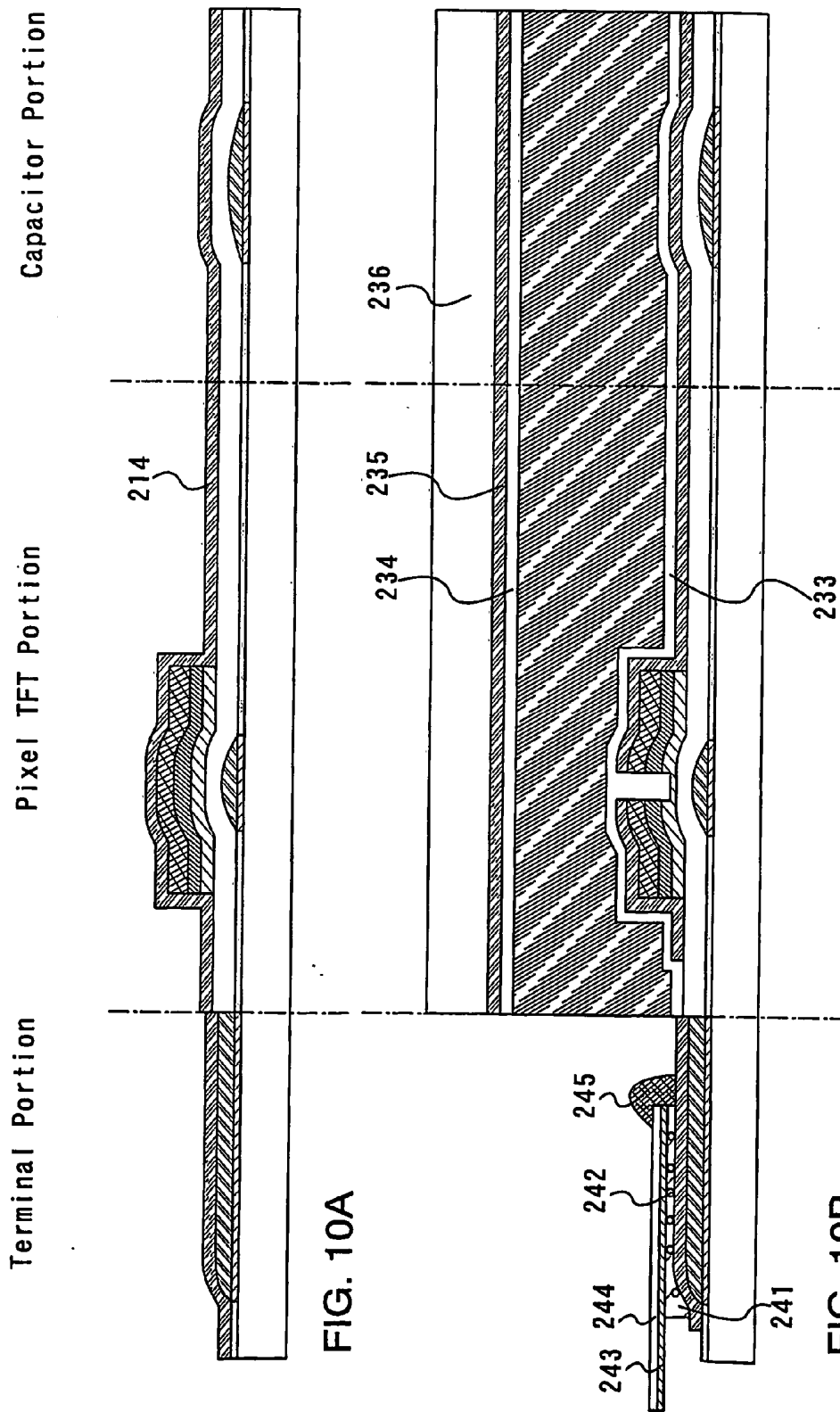

FIG. 10A

FIG. 10B

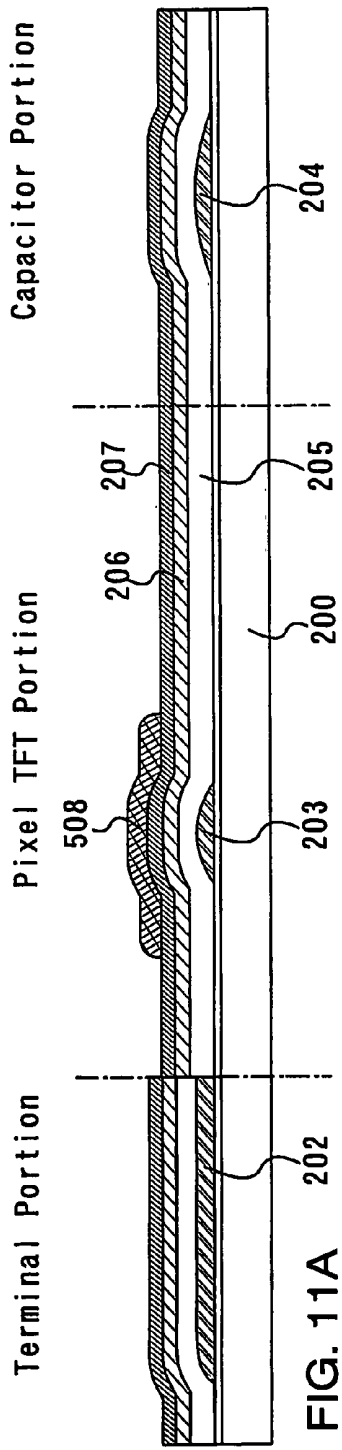

FIG. 11A

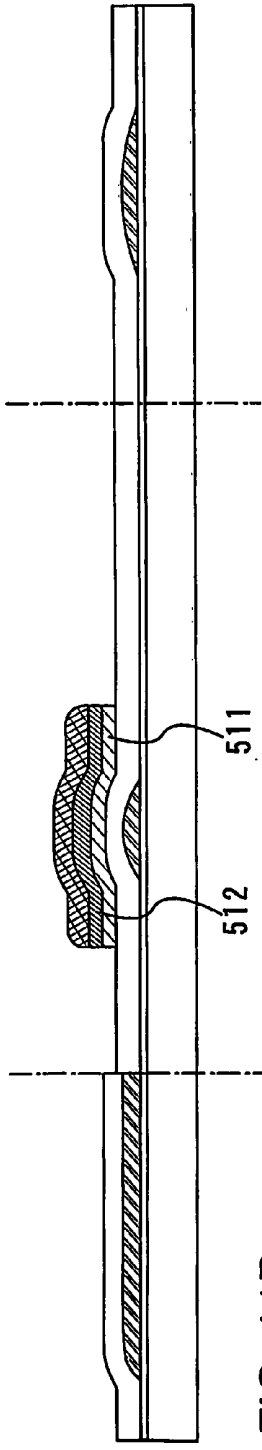

FIG. 11B

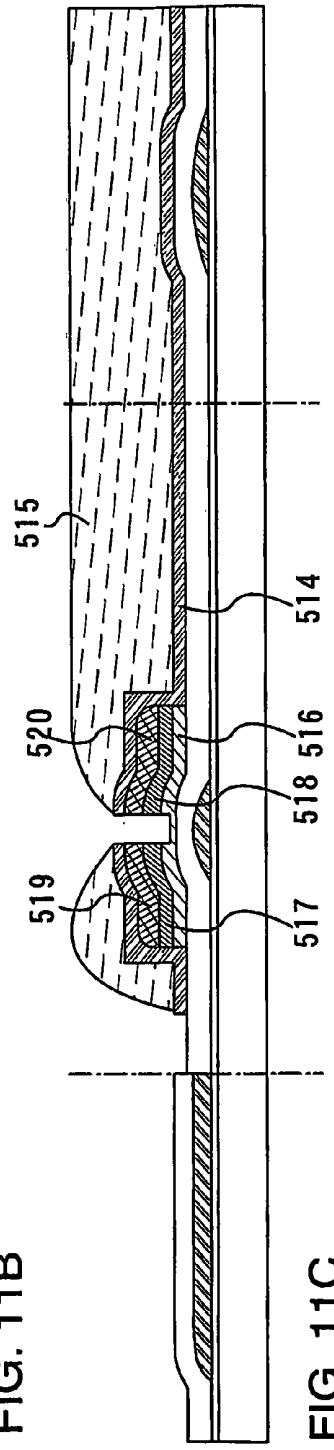

FIG. 11C

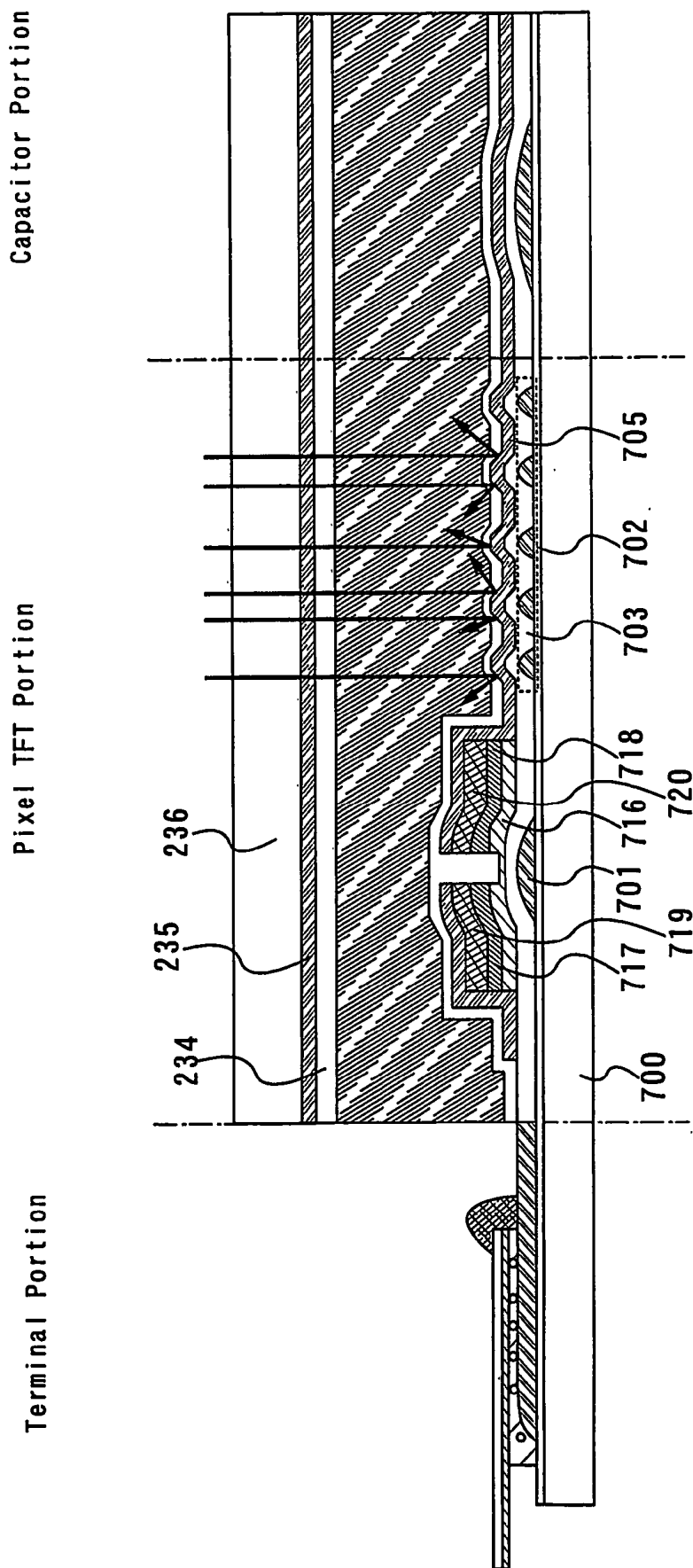

FIG. 12

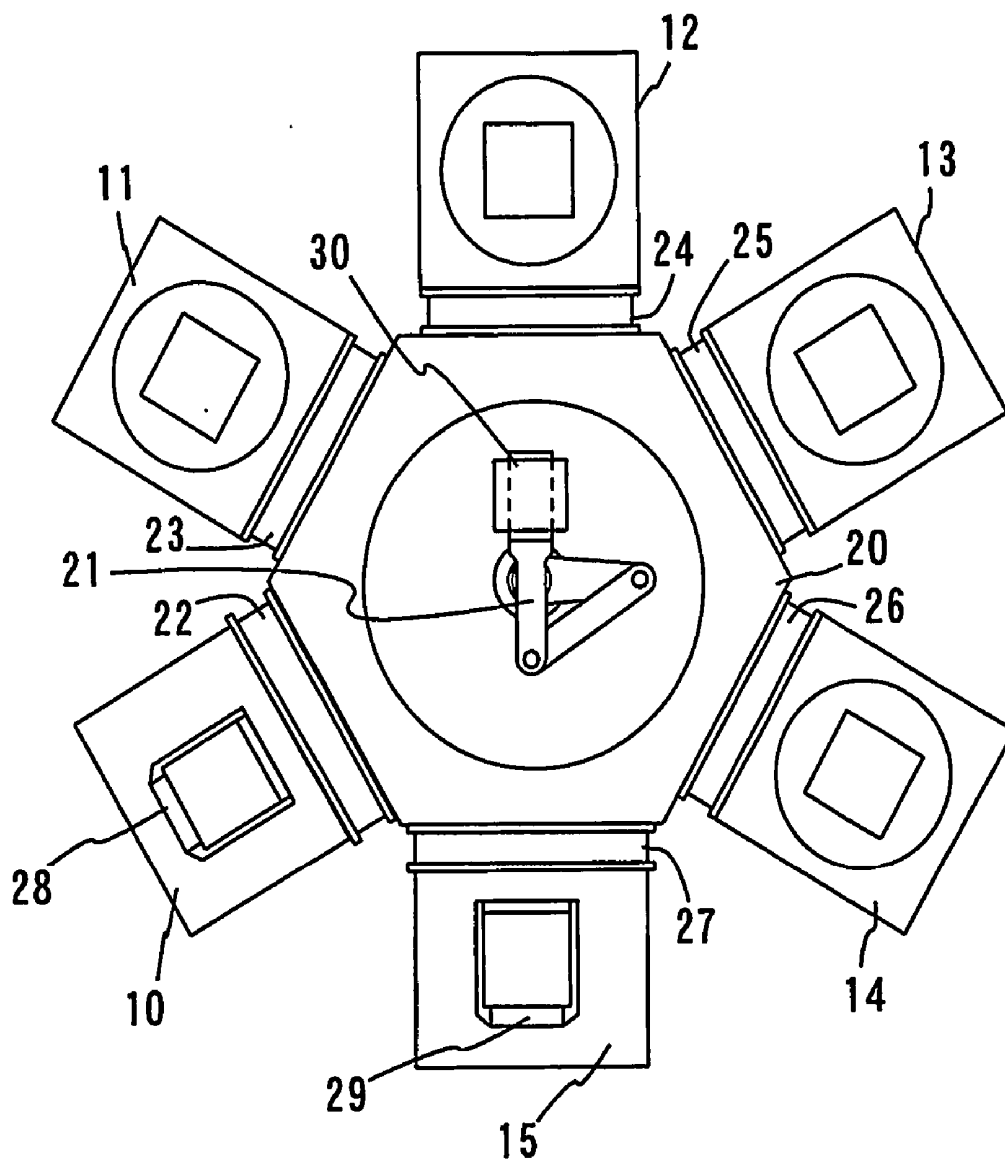

FIG. 13

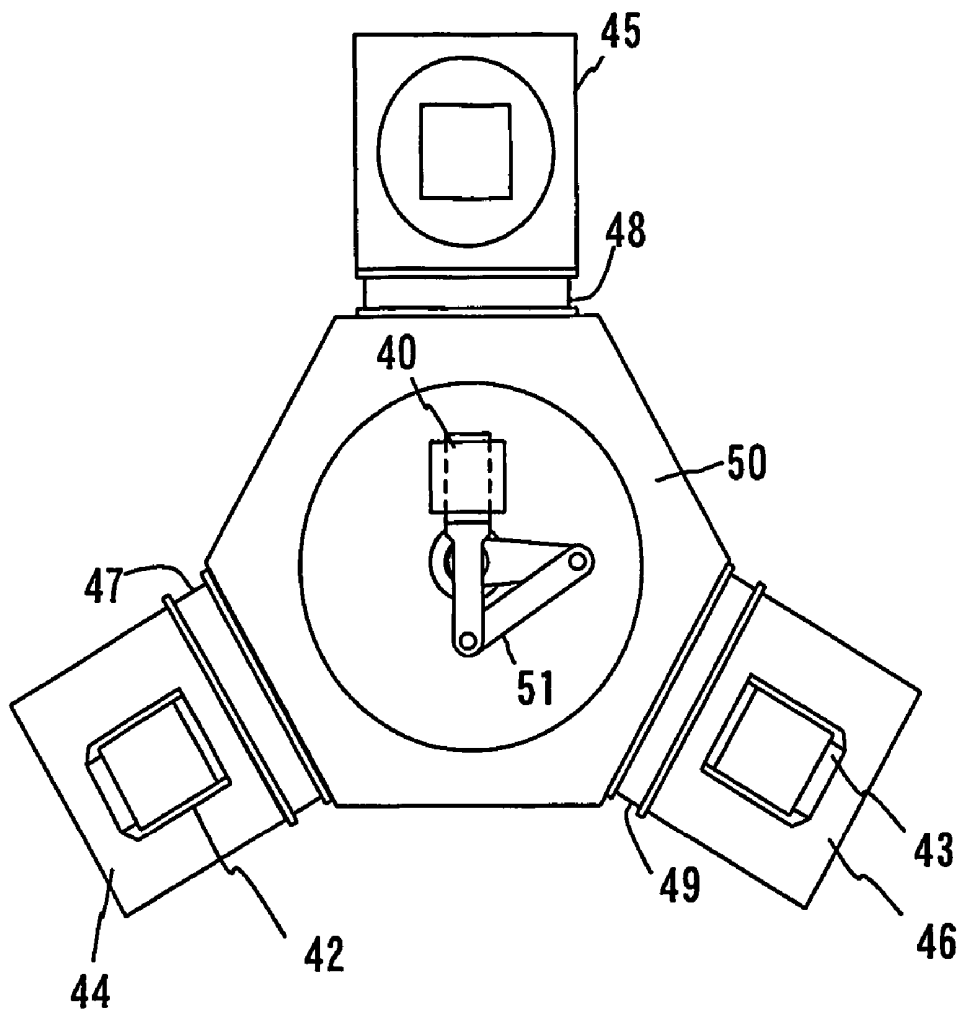

FIG. 14

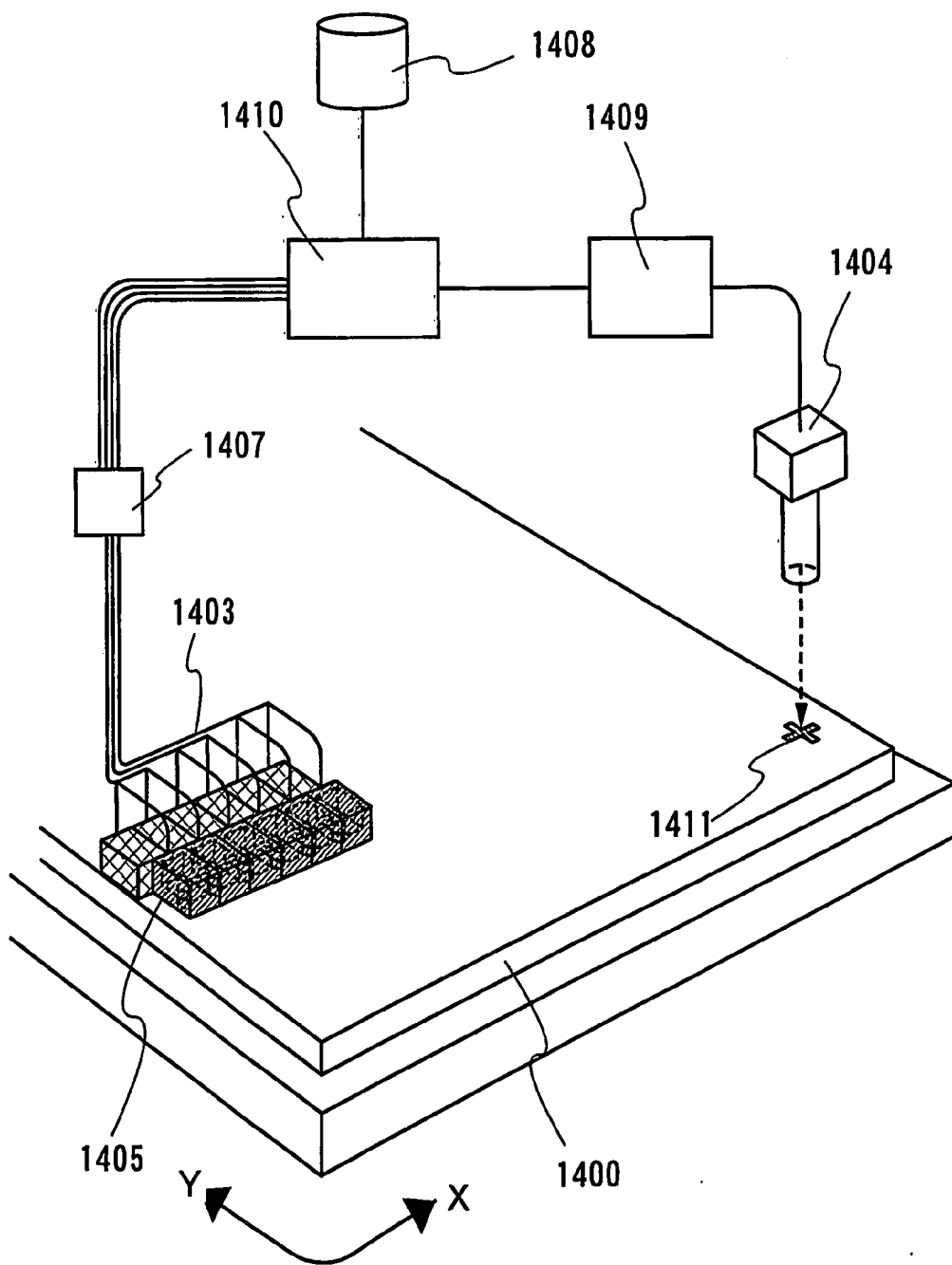

FIG. 15

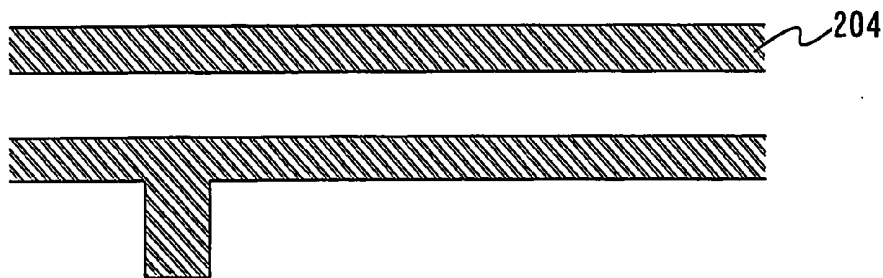
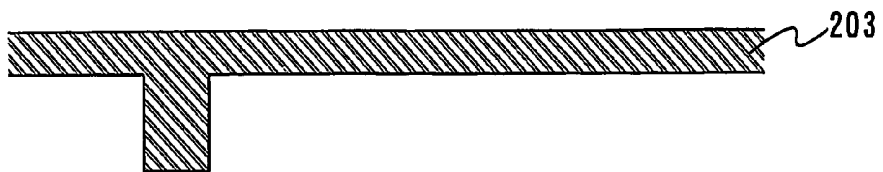

FIG. 16

FIG. 17A

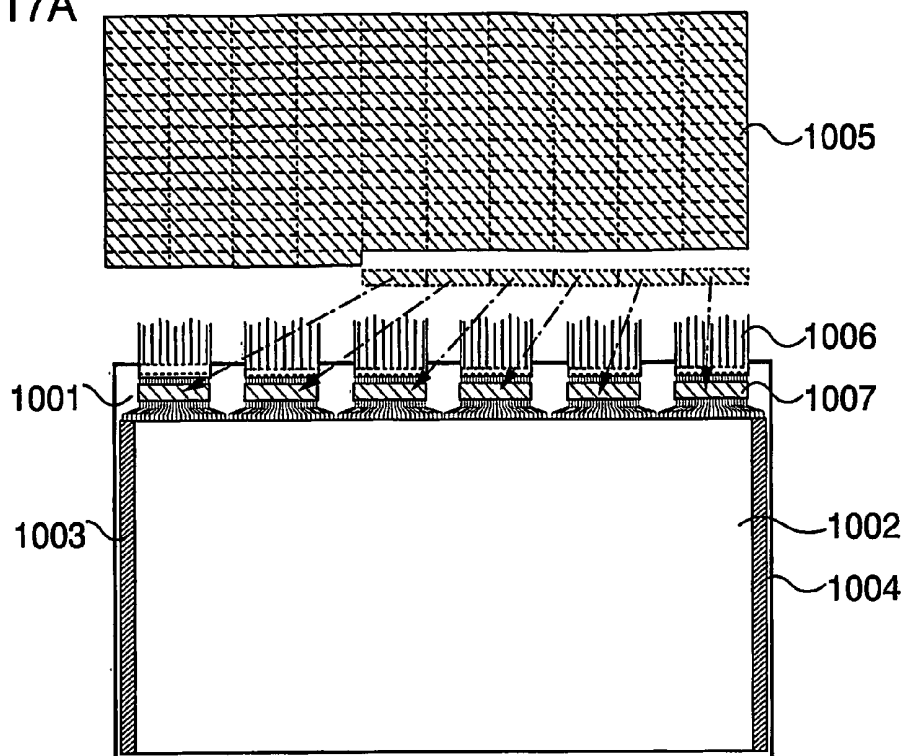

FIG. 17B

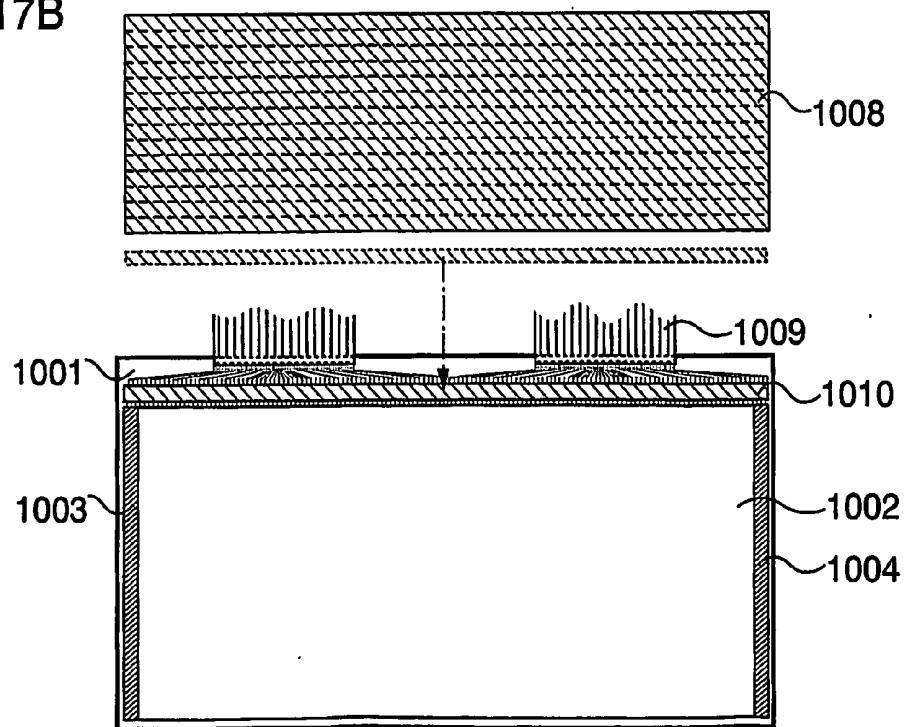

FIG. 18A

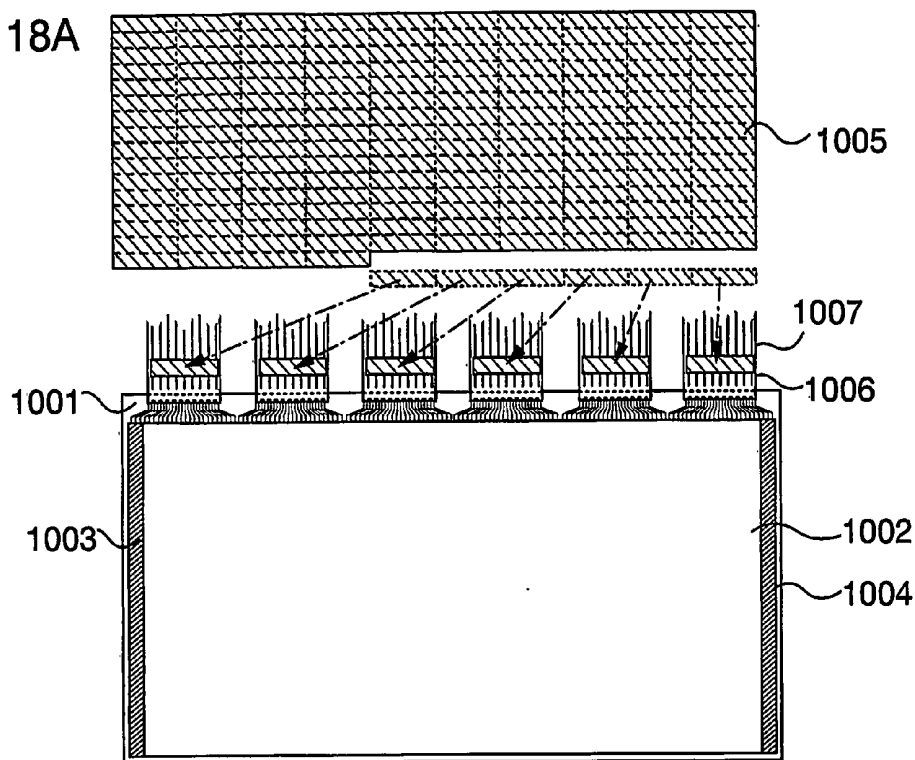

FIG. 18B

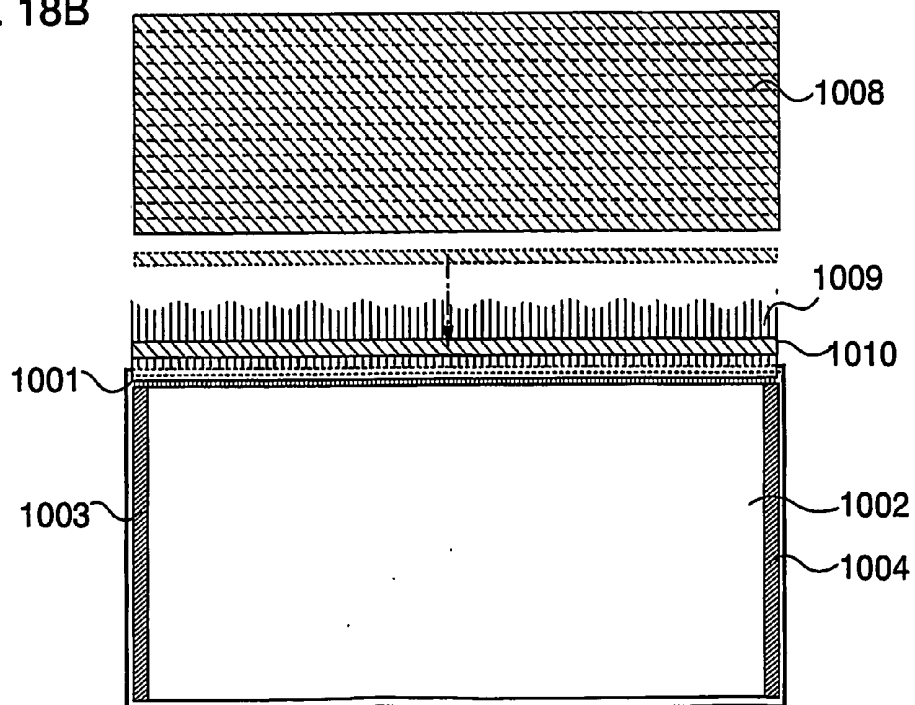

FIG. 19A

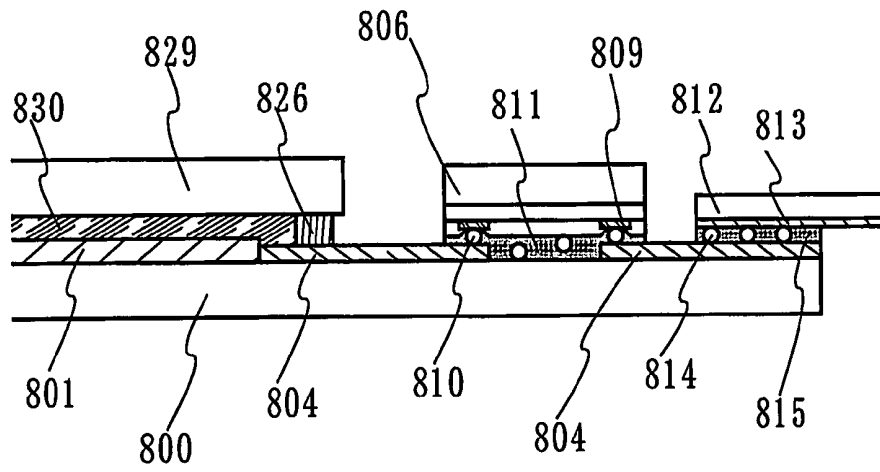
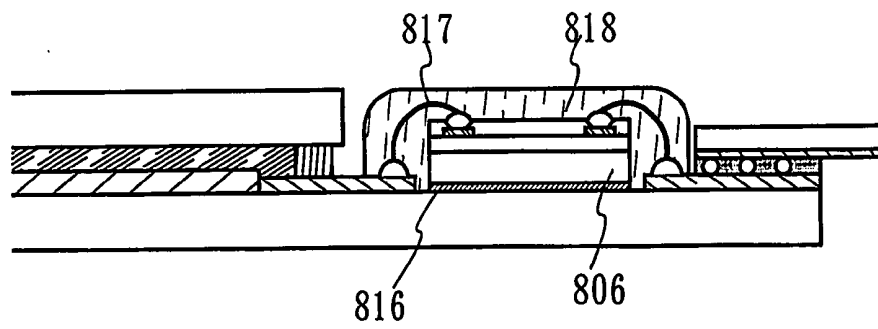

FIG. 19B



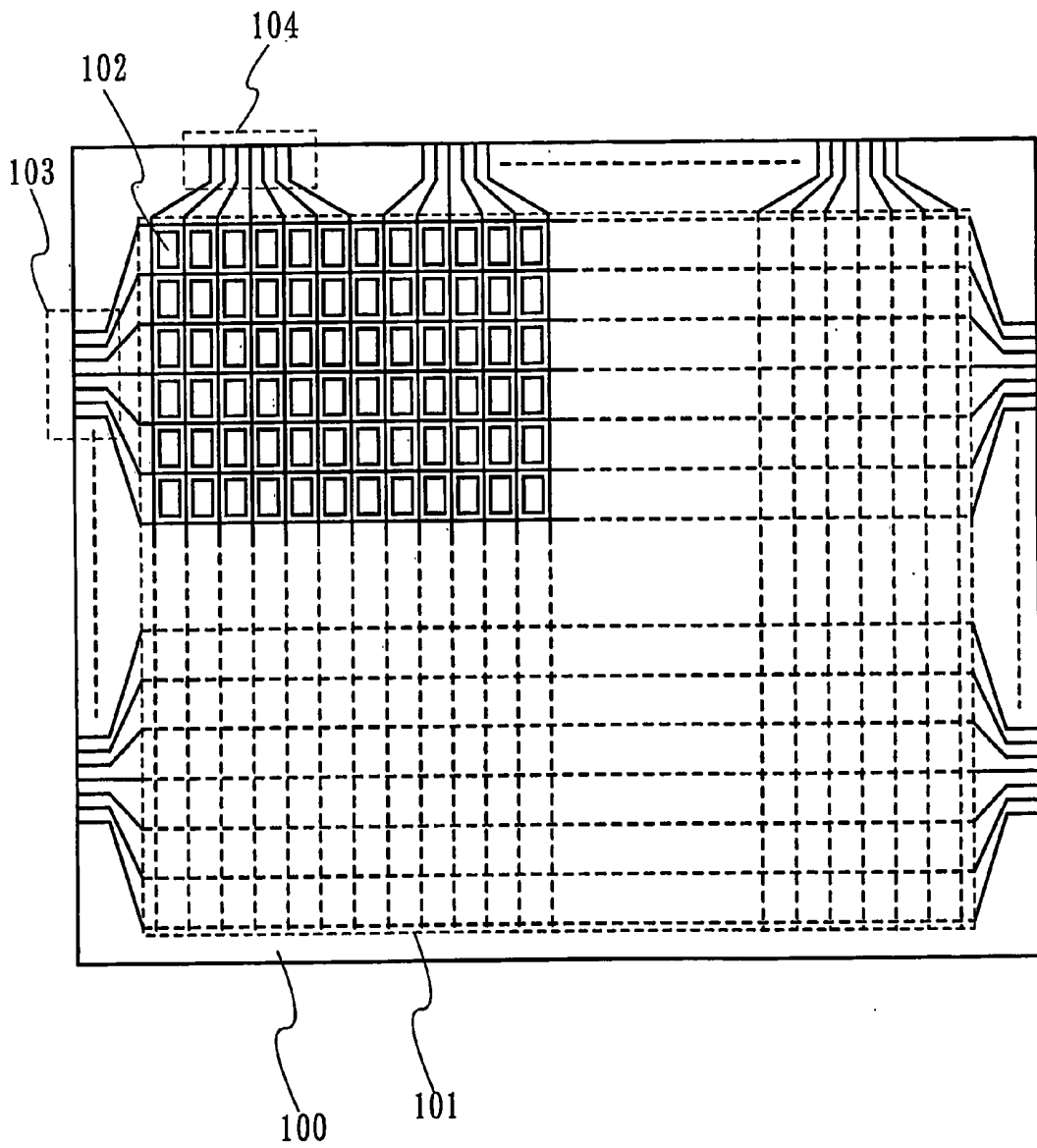

FIG. 20

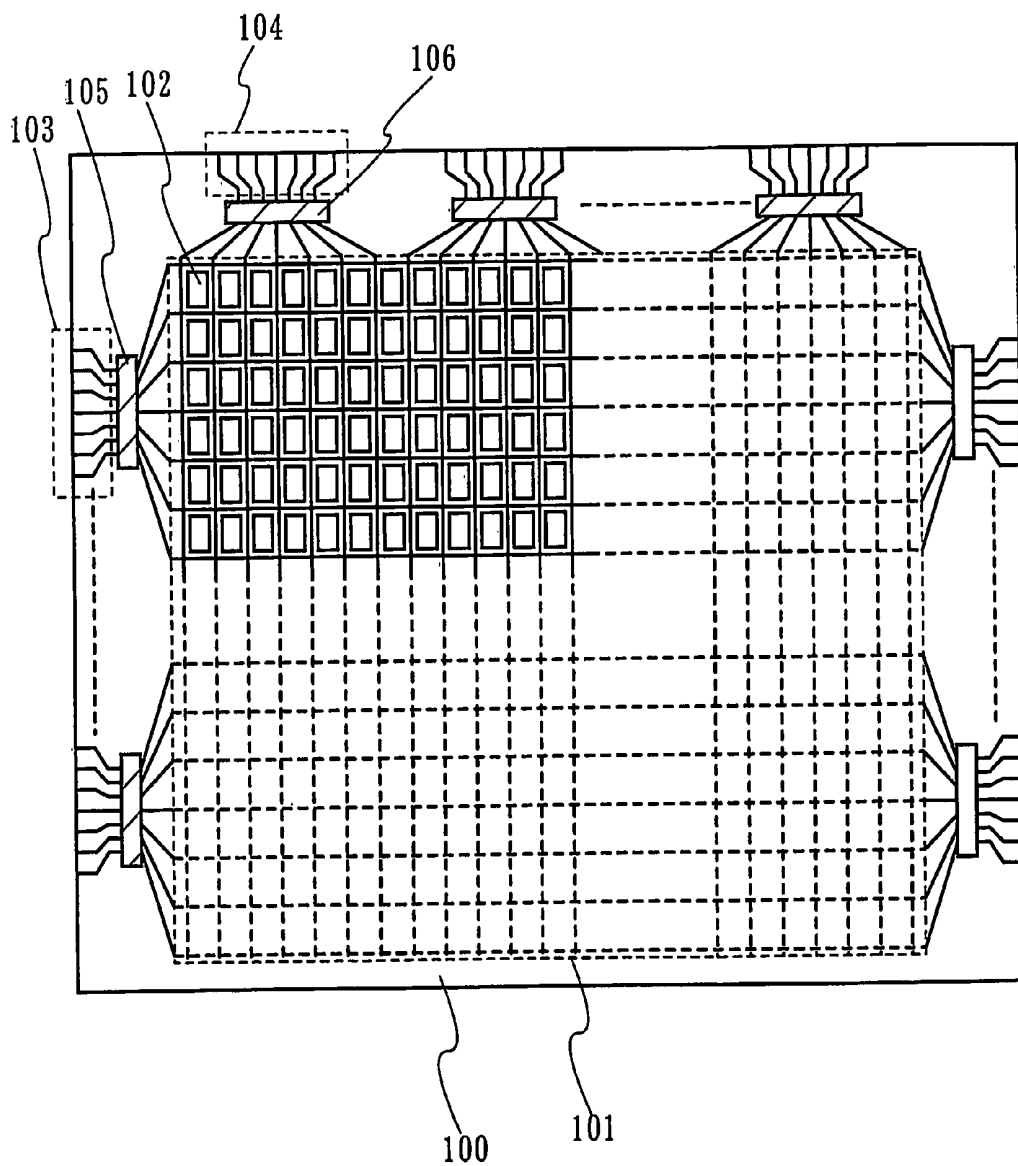

FIG. 21

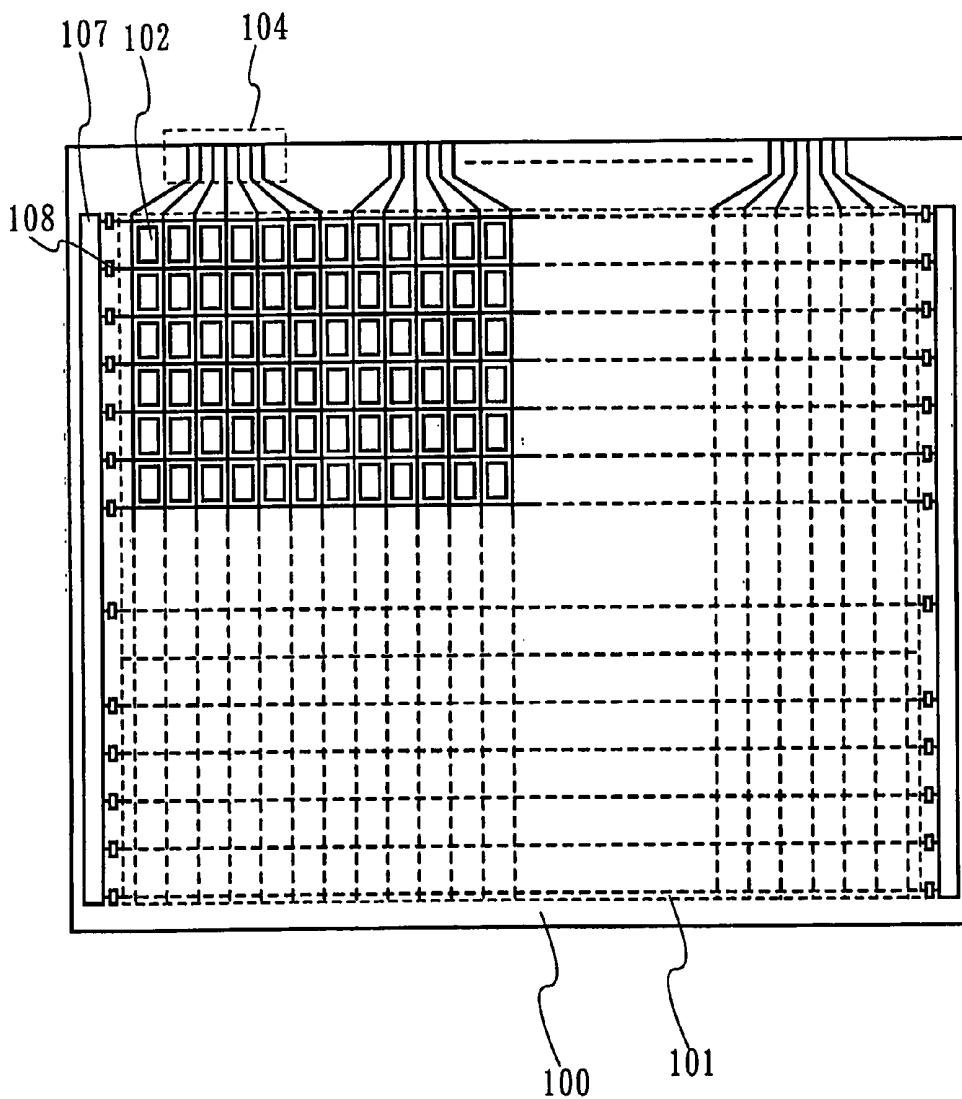

FIG. 22

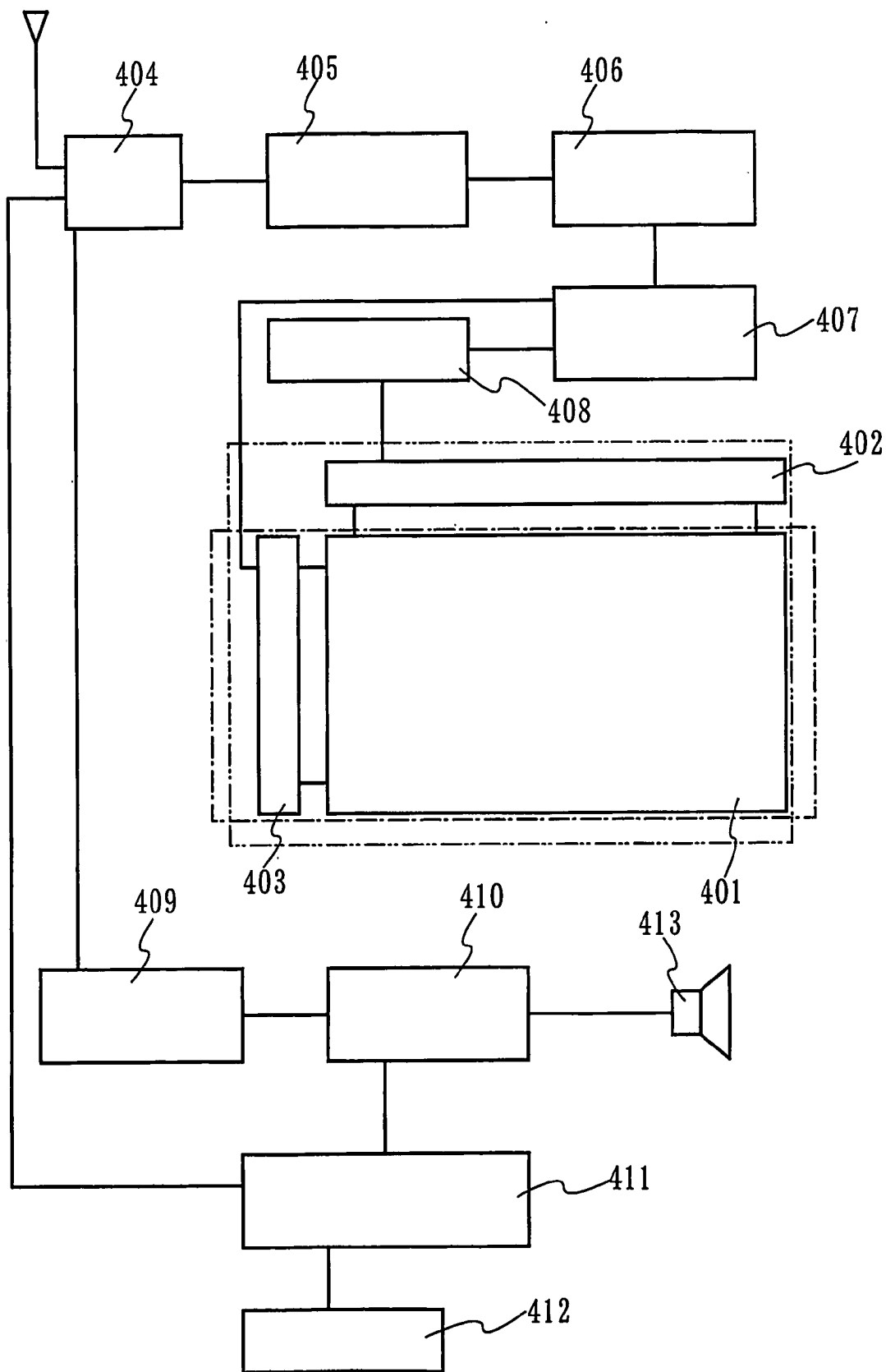

FIG. 23

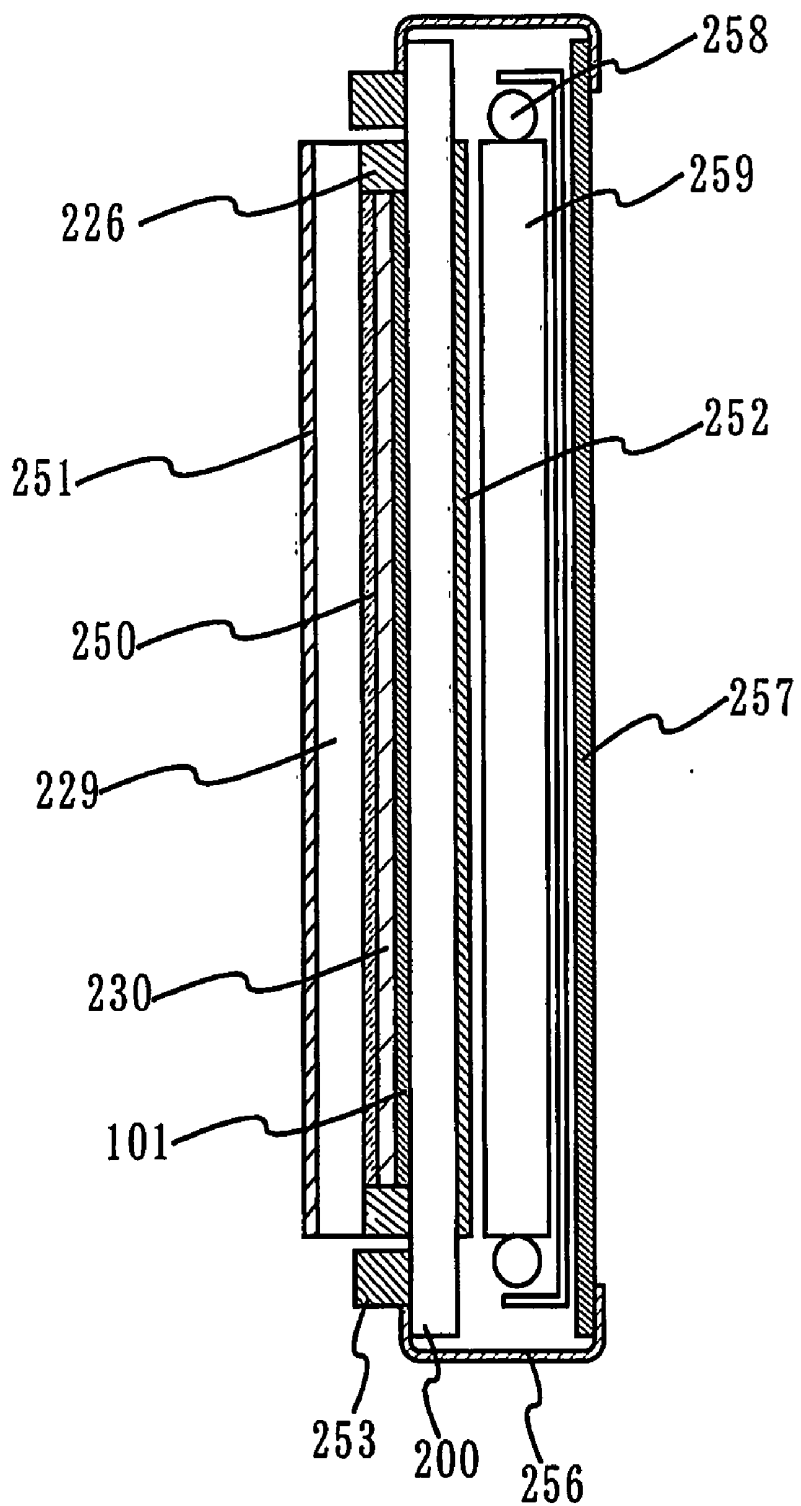

FIG. 24

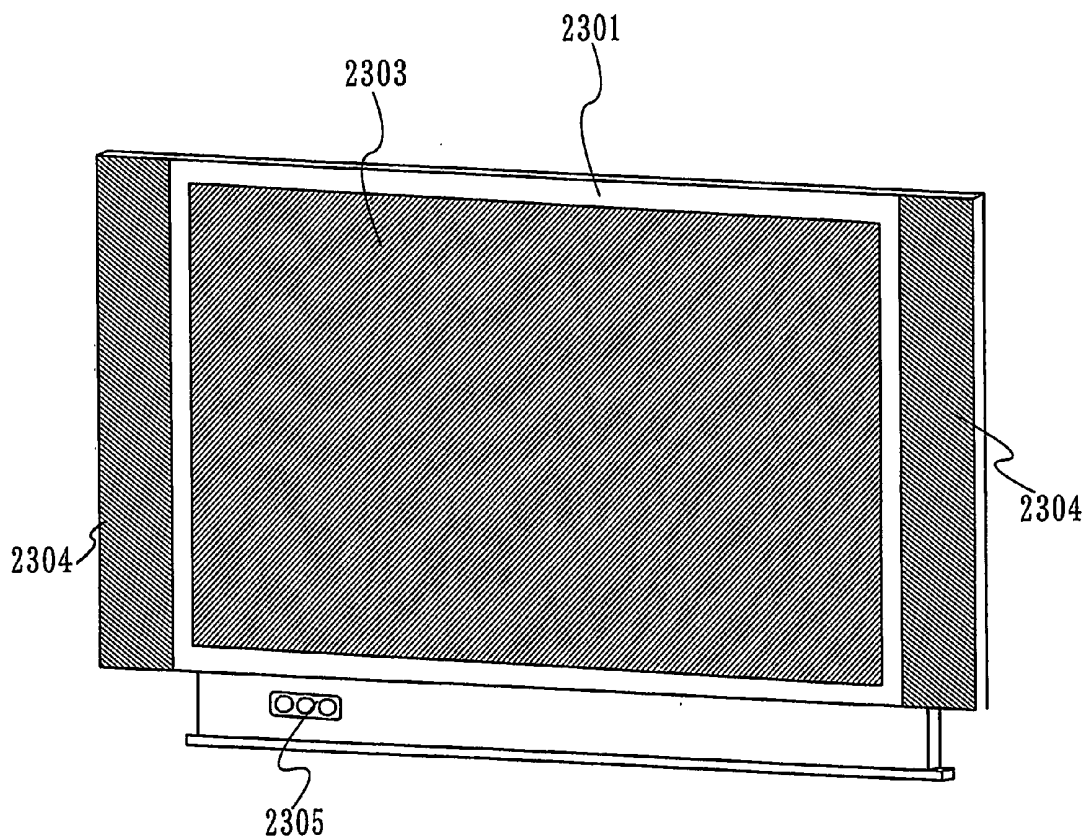

FIG. 25

DESCRIPTION OF NUMERALS

203 gate wiring, 223 gate wiring, 219 source wiring, 239 source wiring, 220 pixel electrode, 214
light-transmitting conductive film, 204 capacitor wiring, 228 wiring, 100 substrate, 101 pixel
portion, 102 pixel, 103 scan line input terminal, 104 signal line input terminal, 107 scan line
5 input terminal, 1400 substrate, 1403 liquid droplet ejection means, 1404 image pickup means,
1405 head, 1407 control means, 1408 memory medium, 1409 image processing means, 1410
computer, 1411 marker, 200 substrate, 201 conductive layer, 202 gate wiring layer, 203 gate
electrode layer, 204 capacitor wiring layer, 205 gate insulating layer, 206 semiconductor film,
207 semiconductor film, 208 metal film, 209 mask, 211 semiconductor film, 212 semiconductor
10 film, 213 metal film, 214 light-transmitting conductive film, 215 mask, 216 semiconductor film,
217 source region, 218 drain region, 219 source electrode, 220 drain electrode, 221 pixel
electrode, 227 aperture, 228 light-transmitting conductive film, 231 TFT, 232 storage capacitor,
234 insulating film, 235 conductive film, 236 counter substrate, 237 liquid crystal layer, 241
adhesive, 242 particles, 243 copper wiring, 244 organic resin film, 245 resin layer, 280 barrier
15 film, 281 barrier film, 309 mask, 305 insulating film, 311 semiconductor film, 312
semiconductor film, 313 metal film, 316 semiconductor film, 317 source region, 318 drain
region, 319 source electrode, 320 drain electrode, 321 insulating film, 322 semiconductor film,
323 semiconductor film, 324 metal film, 325 light-transmitting conductive film, 330 pixel
electrode, 140 insulating film, 141 insulating film, 10 load lock chamber, 11 first chamber, 12
20 second chamber, 13 third chamber, 14 fourth chamber, 15 load lock chamber, 20 common
chamber, 21 robot arm, 22 gate valve, 23 gate valve, 24 gate valve, 25 gate valve, 26 gate valve,
27 gate valve, 28 cassette, 29 cassette, 30 processing substrate, 40 processing substrate, 42
cassette, 43 cassette, 44 load lock chamber, 45 chamber, 46 load lock chamber, 700 substrate,
701 wiring, 702 projection portion, 703 gate insulating film, 705 pixel electrode, 706
25 semiconductor film, 717 source region, 718 drain region, 719 source electrode, 720 drain
electrode, 508 metal film, 511 semiconductor film, 512 N-type semiconductor film, 515 mask,
516 semiconductor film, 517 source region, 518 drain region, 519 source electrode, 520 drain
electrode, 521 pixel electrode, 1001 substrate, 1002 pixel portion, 1003 driver circuit on a scan
side, 1004 driver circuit on a scan side, 1005 substrate, 1006 tape, 1007 driver IC, 1008 substrate,
30 1009 tape, 1010 driver IC, 800 substrate, 801 pixel region, 806 driver IC, 804 signal line input

terminal, 829 counter substrate, 826 sealing material, 830 liquid crystal layer, 812 PFC, 815 resin,
814 conductive particles, 811 resin, 816 adhesive, 401 pixel portion, 402 signal line driver circuit,
403 scan line driver circuit, 404 tuner, 405 image signal processing circuit, 406 image signal
amplifier circuit, 407 control circuit, 408 signal dividing circuit, 409 audio signal amplifier
5 circuit, 410 audio signal processing circuit, 411 control circuit, 412 input portion, 413 speaker,
229 counter substrate, 226 sealing material, 230 liquid crystal layer, 250 colored layer, 251
polarizer, 252 polarizer, 256 flexible wiring substrate, 257 circuit substrate, 258 cold cathode
tube, 259 light guide, 2301 housing, 2303 display screen, 2304 speaker, 2305 operating
switch, 105 first amorphous semiconductor film, 106 second amorphous semiconductor film,
10 109 first conductive film.

LIQUID CRYSTAL DISPLAY DEVICE AND MANUFACTURING METHOD THEREOF

TECHNICAL FIELD

[0001] The present invention relates to a liquid crystal display device having a circuit formed of a thin film transistor (TFT) and to a manufacturing method thereof.

BACKGROUND ART

[0002] In recent years, a technology to form a thin film transistor by using a semiconductor thin film (film thickness of about several nm to several hundred nm) formed on a substrate having an insulating surface is attracting attentions. A thin film transistor, which is widely applied to electronic devices such as an IC and an electronic optical device, is rapidly developed in particular as a switching element of an image display device.

[0003] In general, a liquid crystal display device is known as an image display device using a thin film transistor. An active matrix liquid crystal display device is becoming to be more used which can provide an image in higher resolution as compared to a passive matrix liquid crystal display device. In an active matrix liquid crystal display device, a pixel electrode provided in each of the pixels in matrix is selectively driven to form a display pattern on a display. That is, by applying a voltage between a selected pixel electrode and a counter electrode corresponding to the selected pixel electrode, a liquid crystal layer between the pixel electrode and the counter electrode is optically modulated. This optical modulation is recognized as a display pattern by an observer.

[0004] Application range of such an active matrix liquid crystal display device is expanding and demands for a high resolution, high aperture ratio, and high reliability are increasing in accordance with a display size becoming large. At the same time, demands for the improvement of productivity and cost reduction are increasing.

[0005] The production cost of a conventional active matrix liquid crystal display device is high since TFTs are formed on a substrate by using a number of photo masks by photolithography technology. In order to improve the productivity and yield, it is considered efficient to reduce the number of steps.

DISCLOSURE OF THE INVENTION

[0006] By using one photo mask in the manufacturing steps of a liquid crystal display device, steps such as resist coating, prebaking, exposure, development, and postbaking, as well as the formation of a covering film, etching, resist peeling, rinsing, drying and the like before and after the aforementioned steps are required, which make the process complicated.

[0007] In view of the aforementioned problem, according to the invention, the number of steps for forming a thin film transistor is reduced in order to reduce the production cost and improve the yield of an active matrix liquid crystal display device.

[0008] In order to solve the aforementioned problem, a channel-etch type bottom gate TFT structure (inverted staggered TFT) is employed to pattern a source region and a

drain region, and a pixel electrode with the same mask. Moreover, according to the invention, among the patterns required to manufacture a liquid crystal display device such as a conductive layer for forming a wiring layer or an electrode, a mask for forming a predetermined pattern and the like, at least one or more of them is formed by a method by which a pattern can selectively be formed, thereby manufacturing a liquid crystal display device. As a method for selectively forming a pattern, a liquid droplet ejection method is used in which a liquid droplet of composition prepared for a specific purpose is selectively ejected to form a predetermined pattern for forming a conductive film, an insulating film and the like.

[0009] The invention is a liquid crystal display device comprising a gate wiring, a source wiring, a pixel electrode, and a thin film transistor. The gate wiring formed on an insulating surface, a semiconductor film formed on the gate wiring, a source region and a drain region formed on the semiconductor film, the source wiring formed on the source region, a drain electrode formed on the drain region, a barrier film formed so as to cover one end surface of the source wiring and the drain electrode, and the pixel electrode formed on the drain electrode and the barrier film are provided. The one end surface of the drain region approximately corresponds to the end surfaces of the semiconductor film and the drain electrode.

[0010] Further, according to the aforementioned structure of the invention, another end surface approximately corresponds to an end surface of the pixel electrode and another end surface of the drain electrode.

[0011] Further, the invention is a light-transmitting liquid crystal display device of which pixel electrode is formed of a light-transmitting conductive film.

[0012] Further, the invention is a reflective liquid crystal display device of which pixel electrode is formed of a film containing Ag (silver), Au (gold), Cu (copper), W (tungsten), and Al (aluminum) as its main component or lamination of these films.

[0013] Further, according to the aforementioned structure, the semiconductor film is a semi-amorphous semiconductor containing hydrogen and halogen element and having a crystalline structure.

[0014] According to the invention, composition is selectively ejected on an insulating surface to form a gate wiring, an insulating film that covers the gate wiring, a first semiconductor film on the insulating film, a second semiconductor film containing impurity elements which impart N-type on the first semiconductor film, and a first conductive film on the second semiconductor film. The first semiconductor film, the second semiconductor film, and the first conductive film are selectively removed by using a first mask to form a pattern of laminated films of the first conductive film, the second semiconductor film, and the first semiconductor film, and a second conductive film overlapped in contact with the laminated films. A portion of the first semiconductor film, the second semiconductor film, the first conductive film, and the second conductive film is selectively removed by using a second mask to form a source region and a drain region formed of the second semiconductor film and a pixel electrode formed of the second conductive film containing the impurity elements which impart N-type.

[0015] Further, according to the aforementioned structure of the invention, a barrier film is formed on an end surface of the laminated films of the first conductive film, the second conductive film, and the first semiconductor film by selectively ejecting composition.

[0016] Further, according to the invention, the insulating film, the first semiconductor film, the second semiconductor film, and the first conductive film are formed sequentially without being exposed to the atmosphere.

[0017] Further, according to the aforementioned structure, the first mask and the second mask are formed by selectively ejecting the composition. Further, the second conductive film is formed by selectively ejecting the composition.

[0018] Further, according to the aforementioned structure of the invention, a first conductive film is formed by selectively ejecting the composition containing conductive material and the first semiconductor film and the second semiconductor film are etched with the first conductive film as a mask.

[0019] According to the invention, as a wiring layer and a mask can be directly patterned by ejecting composition, utilization efficiency of material can be improved. Moreover, manufacturing steps of a liquid crystal display device can be simplified.

BRIEF DESCRIPTION OF THE DRAWINGS

[0020] FIG. 1 is a top plan view of the invention.

[0021] FIGS. 2A to 2C are sectional diagrams showing manufacturing steps of a liquid crystal display device of the invention.

[0022] FIGS. 3A to 3C are sectional diagrams showing manufacturing steps of a liquid crystal display device of the invention.

[0023] FIGS. 4A and 4B are sectional diagrams showing manufacturing steps of a liquid crystal display device of the invention.

[0024] FIGS. 5A to 5C are sectional diagrams showing manufacturing steps of a liquid crystal display device of the invention.

[0025] FIGS. 6A and 6B are sectional diagrams showing manufacturing steps of a liquid crystal display device of the invention.

[0026] FIG. 7 is a sectional diagram of a liquid crystal display.

[0027] FIG. 8 is a sectional diagram showing a manufacturing step of a liquid crystal display device of the invention.

[0028] FIGS. 9A to 9C are sectional diagrams showing manufacturing steps of a liquid crystal display device of the invention.

[0029] FIGS. 10A and 10B are sectional diagrams showing manufacturing steps of a liquid crystal display device of the invention.

[0030] FIGS. 11A to 11C are sectional diagrams showing manufacturing steps of a liquid crystal display device of the invention.

[0031] FIG. 12 is a sectional diagram of a reflective electronic optical device.

[0032] FIG. 13 is a top plan view of a manufacturing apparatus.

[0033] FIG. 14 is a top plan view of a manufacturing apparatus.

[0034] FIG. 15 is a diagram showing a structure of a liquid droplet ejection apparatus which can be applied to the invention.

[0035] FIG. 16 are sectional diagrams showing manufacturing steps of a liquid crystal display device of the invention.

[0036] FIGS. 17A and 17B are diagrams showing methods for mounting a driver circuit of a liquid crystal display device of the invention.

[0037] FIGS. 18A and 18B are diagrams showing methods for mounting a driver circuit of a liquid crystal display device of the invention.

[0038] FIGS. 19A and 19B are diagrams showing methods for mounting a driver circuit of a liquid crystal display device of the invention.

[0039] FIG. 20 is a top plan view showing a structure of a liquid crystal display device of the invention.

[0040] FIG. 21 is a top plan view showing a structure of a liquid crystal display device of the invention.

[0041] FIG. 22 is a top plan view showing a structure of a liquid crystal display device of the invention.

[0042] FIG. 23 is a block diagram showing a major structure of a receiver of a liquid crystal display device of the invention.

[0043] FIG. 24 is a diagram showing a structure of a liquid crystal display device of the invention.

[0044] FIG. 25 is a view of an example of an electronic apparatus completed by the invention.

BEST MODE FOR CARRYING OUT THE INVENTION

[0045] Although the present invention will be fully described by way of example with reference to the accompanying drawings, it is to be understood that various changes and modifications will be apparent to those skilled in the art. Therefore, unless such changes and modifications depart from the scope of the present invention hereinafter defined, they should be construed as being included therein. Note that common portions among all the drawings are given the same reference numerals in the structure of the invention hereinafter described.

[0046] FIG. 1 is a plan view of a liquid crystal display device of the invention as an example. Here, one pixel configuration among a plurality of pixels arranged in matrix is shown for simplicity.

[0047] The pixel configuration shown in FIG. 1 includes a plurality of gate wirings 203 and 223 disposed in parallel to each other, a plurality of source wirings 219 and 239 arranged so as to cross each of the gate wirings 203 and 223. Further, a pixel electrode 221 formed of a light-transmitting

conductive film is disposed in a region surrounded by the gate wirings **203** and **223**, and the source wirings **219** and **239**. Further, a light-transmitting conductive film **214** covers the source wirings so as not to overlap the pixel electrode **221**.

[**0048**] Further, a capacitor wiring **204** is disposed between and in parallel with the two adjacent gate wirings **203** and **223** under the pixel electrode **221**. This capacitor wiring **204** is provided in all pixels and forms a storage capacitor with an insulating film as a dielectric material which is provided between the pixel electrode **221**.

[**0049**] Further, a switching element is provided around an intersection of the gate wiring **203** and the source wiring **219**. A switching element is typically a TFT. A gate electrode side of a TFT is connected to a scan line while a source or a drain side is connected to a signal line, thereby each pixel can be controlled independently by a signal inputted externally.

[**0050**] The main components of a TFT are a semiconductor film, a gate insulating film, a gate electrode and the like, to which wirings connected to a source and a drain region formed on the semiconductor film are added. As a typical structure of a TFT, there are a top gate (staggered) type in which a semiconductor film, a gate insulating film, and a gate electrode layer are provided from a substrate side, and a bottom gate (inverted staggered) type in which a gate electrode layer, a gate insulating film and a semiconductor film are provided from a substrate side. In the invention, a bottom gate type TFT is used.

[**0051**] A more specific structure of a TFT is that a gate electrode (integrated with a gate wiring), a gate insulating film, a first semiconductor film, a source region and a drain region formed of a second semiconductor film containing impurity elements which impart N-type, a source electrode (integrated with a source wiring) and an electrode (hereinafter also referred to as a drain electrode) are laminated on an insulating substrate.

[**0052**] Further, a gate insulating film, a first amorphous semiconductor film, a second amorphous semiconductor film containing impurity elements which impart N-type are laminated under a source wiring (including a source electrode) and a drain electrode.

[**0053**] In the first amorphous semiconductor film, a region between a region in contact with the source region and a region in contact with the drain region has a thinner film thickness as compared to other regions. This is because a portion of the first amorphous semiconductor film is removed when forming the source region and the drain region by separating the second amorphous semiconductor film containing impurity elements which impart N-type by etching. Moreover, an end surface of the pixel electrode, an end surface of the drain electrode, and an end surface of the drain region approximately correspond to each other by the etching.

[**0054**] Similarly, an end surface of a wiring **228** which covers the source electrode, an end surface of the source electrode, and an end surface of the source region approximately correspond to each other.

[**0055**] A semiconductor film can be formed of an amorphous semiconductor (hereinafter also referred to as "AS")

formed by using a semiconductor material gas typified by silane and germane by vapor deposition and sputtering, a polycrystalline semiconductor obtained by crystallizing the amorphous semiconductor by using light energy and heat energy, a semi-amorphous semiconductor (also referred to as a micro crystal hereinafter also referred to as "SAS") semiconductor and the like. Moreover, a TFT can be formed by using an organic.

[**0056**] An SAS is a semiconductor having an intermediate structure between an amorphous structure and a crystalline structure (including single crystal and polycrystal) and a third state that is stable in free energy. Moreover, an SAS includes a crystalline region having a short range order and lattice distortion. A crystalline region of 0.5 to 20 nm can be observed in at least a part of the film, and Raman spectrum is shifted to a lower frequency side than 520 cm^{-1} in the case where silicon is a main component. Diffraction peaks of (111) and (220) are measured by X-ray diffraction, which are caused by Si crystal grating. Also, hydrogen or halogen of at least 1 atom % or more is included as a neutralizing agent of a dangling bond. An SAS is formed by depositing silicon gas by glow discharge (plasma CVD). The silicon gas is typically SiH_4 , as well as Si_2H_4 , SiH_2Cl_2 , SiHCl_3 , SiCl_4 , SiF_4 and the like. Also, GeF_4 may be mixed as well. The silicon gas may be diluted with one or a plurality of noble gas elements such as H_2 , H_2 and He, Ar, Kr, and Ne. The silicon gas is preferably diluted with the dilution ratio of 2 to 1000 times, at a pressure of approximately 0.1 to 133 Pa, and at a power supply frequency of 1 to 120 MHz, more preferably with a high frequency power of 13 to 60 MHz. It is preferable that a temperature for heating the substrate is 300° C . or less. It is preferable that impurities of atmospheric components such as oxygen, nitrogen, and carbon as impurity elements in the film be $1 \times 10^{20}\text{ cm}^{-3}$ or less. In particular, oxygen concentration is preferably $5 \times 10^{19}/\text{cm}^3$ or less and more preferably $1 \times 10^{19}/\text{cm}^3$ or less.

[**0057**] FIG. **20** is a top plan view showing an overall structure of a liquid crystal display panel according to the invention. A pixel portion **101** in which pixels **102** are arranged in matrix, scan line input terminals **103**, signal line input terminals **104** are provided on a substrate **100** having an insulating surface. Here, FIG. **20** shows a structure of a liquid crystal display panel in which signals inputted to a scan line and a signal line are controlled by an external driver circuit, however, a driver IC **106** may be mounted on the substrate **100** by COG (Chip On Glass) as shown in FIG. **21**. The driver IC **106** may be formed of a single crystalline semiconductor substrate and of a glass substrate on which a circuit is formed of a TFT. Further, in the case of forming a TFT provided in a pixel by an SAS, a scan line driver circuit **107** may be formed on the substrate **100** to be integrated as shown in FIG. **22**.

[**0058**] According to the invention, a pattern of the aforementioned structure is directly formed by liquid droplet ejection method. Here, the liquid droplet ejection method is a method for selectively ejecting (discharging) forming liquid droplets (also referred to as dots) of composition containing materials for a conductive layer, an insulating film and the like to be formed on an arbitrary position, which is also referred to as an ink-jetting method depending on its system.

[**0059**] FIG. **15** shows one mode of a liquid droplet ejection apparatus used for forming a pattern. Each head **1405** of

a liquid droplet ejection means **1403** is connected to a control means **1407**. A computer **1410** controls the control means **1407**, thereby a programmed pattern can be drawn. A timing to draw may be, for example, determined on the basis of a marker **1411** formed on a substrate **1400**. Alternatively, a base point may be determined on the basis of the edges of the substrate **1400**. This is detected by an image pickup means **1404** such as a CCD, and converted into a digital signal by an image processing means **1409**. The computer **1410** recognizes the digital signal and generates a control signal which is sent to the control means **1407**. It is needless to say that data of patterns to be formed on the substrate **1400** are stored in a memory medium **1408**, on the basis of which a control signal is sent to the control means **1407** and thus each head **1405** of the liquid droplet ejection means **1403** can be controlled independently. Note that a head may be scanned in X-Y direction for ejection as well. This is efficient in the case of ejecting on a larger substrate than a width of the head **1405** which ejects liquid droplets. Also, a device itself can be more compact.

Embodiment Mode 1

[**0060**] A manufacturing method of a channel-etch type thin film transistor is described as Embodiment Mode 1.

[**0061**] In this embodiment mode, a manufacturing method of a liquid crystal display device is described. A method for forming an inverted staggered TFT in a pixel portion on a substrate and a method for forming a storage capacitor connected to the TFT are described in details along the process. At the same time, a method for forming an input terminal portion provided in an end portion of the substrate for electrically connecting to a wiring of a circuit provided on another substrate is described.

[**0062**] In FIG. 2A, a substrate **200** may be a non-alkali glass substrate such as a barium borosilicate glass, an aluminoborosilicate glass, or an aluminosilicate glass fabricated by fusion method and a float method, a ceramic substrate as well as a plastic substrate which can resist the processing temperature of the present manufacturing steps, and the like. Further, a semiconductor substrate such as a single crystalline silicon, a metal substrate such as a stainless substrate on which an insulating layer is provided may be applied as well.

[**0063**] It is preferable that a conductive layer **201** formed of a metal material such as Ti (titanium), W (tungsten), Cr (chromium), Al (aluminum), Ta (tantalum), Ni (nickel), Zr (zirconium), Hf (hafnium), V (vanadium), Ir (iridium), Nb (niobium), Pd (palladium), Pt (platinum), Mo (molybdenum), Co (cobalt), or Rh (rhodium) which is formed by sputtering, vapor deposition and the like on the substrate **200**. The conductive layer **201** may be formed in a thickness of 0.01 to 10 nm and can be formed in a single or a laminated structure. Note that the conductive layer **201** is provided for improving an adhesion of the gate electrode layer, therefore, provided that a sufficient adhesion can be obtained, the conductive layer **201** can be omitted and a gate electrode layer may be directly formed on the substrate **200**.

[**0064**] Subsequently, composition containing a conductive material is selectively ejected, thereby a gate wiring layer **202**, a gate electrode layer **203**, and a capacitor wiring layer **204** are formed on the conductive layer **201**. (FIG. 2A) As a conductive material for forming these layers, compo-

sition having metal particles of Ag (silver), Au (gold), Cu (copper), W (tungsten), Al (aluminum), and the like as a main component can be used. Further, light-transmitting indium tin oxide (ITO), indium tin silicon oxide (ITSO) containing silicon oxide may be combined. In particular, it is preferable that the gate wiring layer is lower in resistance. Therefore, a material obtained by diluting or dispersing any one of gold, silver, or copper in a solvent is preferably used. More preferably, silver and copper which are low in resistance are used. In that case, however, a barrier film may be provided in combination in order to prevent impurities. A silicon nitride film and nickel boron (NiB) are used for a barrier film, for example. The solvent may be esters such as butyl acetate, alcohols such as isopropyl alcohol, organic solvents such as acetone, and the like. The surface tension and viscosity are appropriately controlled by controlling the concentration of the solvent and adding surfactant and the like. FIG. 16 shows a top plan view in this phase.

[**0065**] Moreover, the wiring layer may be formed by ejecting silver and copper plating thereafter. In this case, a wiring having a thin width is formed by ejecting composition, and after that, the wiring can be formed wider by plating. Also, rough surface of the ejected silver makes the plating easier. The plating may be performed by dipping a large substrate in a liquid tank or pouring plating solvent over the large substrate.

[**0066**] It is preferable that the diameter of a nozzle used in the liquid droplet ejection method be 0.02 to 100 μm (more preferably 30 μm or less) and the quantity of composition ejected from the nozzle be 0.001 to 100 pl (more preferably 10 pl or less). There are on-demand type and continuous type in the liquid droplet ejection method and either of them may be used. As for the nozzle used in the liquid droplet ejection method, either of a piezoelectric method that utilizes the property of a piezoelectric body which transforms when a voltage is applied, and a thermal method that composition is brought to boil by a heater provided in the nozzle for ejecting the composition may be used.

[**0067**] It is preferable that the object and a nozzle head be as close as possible in order to discharge the composition on a desired position. The distance is preferably about 0.1 to 3 mm (preferably 1 mm or less). One of the nozzle and the object moves while they keep a relative distance to each other, thereby a desired pattern is drawn. Further, the surface of the object may be subject to plasma treatment before the composition is ejected. By applying plasma treatment, the surface of the object can be hydrophilic or lyophobic. For example, the surface of the object becomes hydrophilic to pure water and lyophobic to paste that is diluted with alcohol.

[**0068**] A step for ejecting composition may be performed under reduced pressure. Accordingly, solvent of the composition is evaporated until the ejected composition lands on the object, thus steps for drying and baling can be omitted or shortened. After ejecting the composition, one or both of the steps for drying and baking is performed at normal pressure or under reduced pressure by irradiating laser light, rapid thermal annealing, furnace annealing and the like. The steps for drying and baking are both performed by heat treatment, however, the purposes, temperatures and time are different. For example, drying is performed at 100° C. for three minutes while baking is performed at 200 to 350° C.

for 15 to 120 minutes. For performing the drying and baking favorably, a substrate may be heated in advance. The temperature is 100 to 800° C. (more preferably 200 to 350° C.) though it depends on the material of the substrate and the like. According to this step, the solvent in the composition is evaporated or dispersant is chemically removed and peripheral resin is cured and shrunk, thus fusing and welding are accelerated. The atmosphere for performing this step is oxygen atmosphere, nitrogen atmosphere, or atmospheric air. However, it is preferable to perform in the oxygen atmosphere since the solvent dissolved or dispersed with metal elements is easily removed.

[0069] The laser irradiation may be performed by using a gas laser or solid state laser of continuous oscillation or pulse oscillation. The former gas laser includes an excimer laser, a YAG laser and the like while the latter solid state laser includes a laser using a crystal, such as YAG and YVO₄ doped with Cr, Nd and the like. Note that it is preferable to use a continuous oscillation laser in view of the absorption rate of the laser light. Also, what is called a hybrid laser irradiation method may be used that the pulse oscillation and the continuous oscillation are combined. However, depending on the heat resistance of the substrate, the thermal treatment by laser irradiation is preferably performed instantaneously for several micro seconds to several ten seconds. The rapid thermal annealing (RTA) is performed in an inert gas atmosphere by using an infrared lamp, a halogen lamp and the like to irradiate ultraviolet light to infrared light, thereby the temperature is rapidly increased and heat is applied instantaneously for several micro seconds to several minutes. This treatment is performed instantaneously, therefore, an outermost thin film only can be heated practically without an effect on the underlayer films.

[0070] After forming the gate wiring layer 202, the gate electrode layer 203 and the capacitor wiring layer 204, it is preferable that one of the following two steps is performed to the conductive layer 201 which is exposed on the surface.

[0071] A first method is that the conductive layer 201 which is not overlapped with the gate wiring layer 202, the gate electrode layer 203 and the capacitor wiring layer 204 is insulated to form insulating layers 301 to 304. That is, the conductive layer 201 which is not overlapped with the gate wiring layer 202, the gate electrode layer 203 and the capacitor layer 204 is oxidized and insulated (FIG. 2B). In this manner, in the case of insulating the conductive layer 201, it is preferable to form the conductive layer 201 in a thickness of 0.01 to 10 nm, which is oxidized to be an insulating layer. Note that the conductive layer 201 may be oxidized by being exposed in oxygen atmosphere or applied thermal treatment.

[0072] A second method is that the conductive layer 201 is etched to be removed using the gate wiring layer 202, the gate electrode layer 203, and the capacitor layer 204 as masks. In the case of applying this step, thickness of the conductive layer 201 is not restricted.

[0073] Further, for forming the gate wiring layer 202, the gate electrode layer 203, and the capacitor wiring layer 204 on the substrate 200 by ejecting composition containing a conductive material, a following method may be applied instead of the aforementioned method in order to improve the adhesion between the substrate and the composition.

[0074] First, a base film is formed on the substrate 200 having an insulating surface. The base film is provided for

preventing alkali metal and alkali earth metal such as Na contained in the substrate 200 from dispersing to a semiconductor film and adversely affecting the characteristics of a semiconductor element. Therefore, the base film can be formed by using an insulating film such as silicon oxide, silicon nitride, silicon nitride oxide, titanium oxide, and titanium nitride which can suppress dispersion of alkali metal and alkali earth metal to a semiconductor film. In particular, it is preferable that the base film is formed of a material that is highly adhesive to a material of the gate electrode. For example, in the case of using Ag, Cu or a lamination of Ag and Cu for the gate wiring layer, the gate electrode layer, or the capacitor wiring layer, it is preferable to form a base film formed of titanium oxide (TiOx). Note that the base film may have a single layer or laminated structure. Here, the base film has a laminated structure of a first base film and a second base film. As the first base film, a silicon oxynitride film is formed in thickness of 10 to 200 nm (more preferably 50 to 200 nm) by plasma CVD with source gases of SiH₄, N₂O, NH₃, and H₂, at a pressure of 0.3 Torr (39.9 Pa), an RF power of 50 W, an RF frequency of 60 MHz, and a substrate temperature of 400° C. As the second base film, a silicon oxynitride film is formed in thickness of 50 to 200 nm (more preferably 150 to 200 nm) by plasma CVD with source gases of SiH₄, and N₂O, at a pressure of 0.3 Torr (39.9 Pa), an RF power of 150 W, an RF frequency of 60 MHz, and a substrate temperature of 400° C.

[0075] In the case of using a substrate containing even a slight amount of alkali metal and alkali earth metal such as a stainless substrate or a plastic substrate, it is efficient to provide a base film in view of preventing dispersion of impurities. On the other hand, in the case where the dispersion of the impurities do not affect much such as a quartz substrate, a base film is not necessarily provided. That is, the base film is not necessarily required as long as the impurities can be prevented from dispersing to the semiconductor film. For example, in the case of forming a semiconductor film on a gate electrode with a gate insulating film interposed therebetween, the gate insulating film can prevent the impurities from dispersing to the semiconductor film, therefore, the base film is not required to be provided.

[0076] After that, plasma treatment is performed on the surface on which the gate electrode is to be formed. In this embodiment mode, the gate electrode is formed on the base film, therefore, plasma treatment is applied to the base film. The plasma treatment may be performed without contact to the surface on which the gate electrode is to be formed. The plasma treatment is performed with atmospheric air, oxygen or nitrogen as a process gas, and at a pressure of several ten to 800 Torr (106400 Pa), or more preferably 700 (93100 Pa) to 800 Torr (an atmospheric pressure or a pressure close to it). Moreover, the plasma treatment may be performed with an RF power source or an AC power source. For example, plasma is generated by using an AC power source with alternate voltage of 100 V, frequency of 13.56 MHz and the like and changing the power. In order to discharge a stable plasma, a pulse is applied at an interval of voltage width of 2 to 4 μsec. By applying this plasma treatment, a surface is modified so that the surface becomes less wettable to liquid such as alcohol and oil. After that, the gate wiring layer, the gate electrode layer and the capacitor wiring layer are formed by ejecting the composition containing a conductive material on the substrate.

[0077] By using any one of the aforementioned methods, the gate wiring layer, the gate electrode layer and the capacitor wiring layer can be formed on the substrate 200.

[0078] Next, a gate insulating film 205 is formed in a single layer or a laminated structure by plasma CVD and sputtering. In particular, it is preferably formed by laminating three layers; an insulating film formed of silicon nitride, an insulating film formed of silicon oxide, and an insulating film formed of silicon nitride. Here, the gate insulating film 205 is shown as a single layer for simplicity. Note that in order to form a dense insulating film with less leak current at a low deposition temperature, it is preferable to include a noble gas element such as argon in reaction gas and mix it in the insulating film. By forming a first layer of silicon nitride or silicon nitride oxide which is in contact with the gate wiring layer 202, the gate electrode layer 203, and the capacitor wiring layer 204, deterioration due to oxidization can be prevented.

[0079] Next, a semiconductor film 206 is formed on the gate insulating film 205. The semiconductor film 206 is formed of an AS or an SAS formed by vapor deposition or sputtering using a semiconductor material gas typified by silane and germane.

[0080] In the case of employing plasma CVD, AS is formed by using SiH_4 or mixed gas of SiH_4 and H_2 which are semiconductor material gases. By diluting SiH_4 with H_2 3 to 1000 times or diluting Si_2H_6 and GeF_4 at a gas flow ratio of 20 to 40:0.9, an SAS of which composition ratio of Si is 80% or more can be obtained. In particular, the latter is preferable since the semiconductor film 206 can have crystallinity at an interface between the base layer.

[0081] Next, an N-type or P-type semiconductor film 207 (hereinafter referred to as a semiconductor film 207) is formed on the semiconductor film 206, as a semiconductor containing impurity elements of one conductivity type. The semiconductor film 207 may be formed by using silane gas and phosphine gas and can be formed of an AS or an SAS.

[0082] Next, a conductive metal film 208 is formed by sputtering or vacuum deposition method. The conductive metal film 208 may be formed of any material as long as it is a metal material which can have an ohmic contact with the semiconductor film 207. An element selected from Al, Cr, Ta, and Ti, an alloy containing the aforementioned element, an alloy film in which the aforementioned elements are combined, and the like can be used.

[0083] By employing the aforementioned steps, the gate insulating film 205 to the metal film 208 can be formed sequentially without being exposed to the air. That is, an interface of each lamination can be formed without being contaminated by atmospheric components or impurity elements which float in the air, therefore, variation in characteristics of TFTs can be reduced.

[0084] Moreover, the metal film 208 can be formed by ejecting a conductive composition on the semiconductor film 207. The conductive material for forming the metal film 208 may be composition containing metal particles of Ag, Au, Cu, W, Al, and the like as a main component. Further, indium tin oxide which transmits light, ITSO formed of indium tin oxide and silicon oxide, organic indium, originating, zinc oxide, titanium nitride and the like can be used in combination as well.

[0085] Next, a mask 209 is formed by selectively ejecting composition on the metal film 208. As a material of the mask 209, resin material such as epoxy resin, acryl resin, phenol resin, novolac resin, melamine resin, and urethane resin is used. Further, organic material such as benzocyclobutene, parylene, flare, polyimide which transmits light, a compound material formed by polymerization of siloxane polymers and the like, composition material containing water-soluble homopolymers and water-soluble copolymers may be used. Alternatively, a commercial resist material containing photosensitive agent may be used. For example, novolac resin as a typical positive type resist and naphthoquinone diazide compound as a photosensitive agent, a base resin as a negative type resist and diphenylsilanediol, an acid-forming agent and the like may be used. When using any of the aforementioned materials, the surface tension and viscosity are appropriately controlled by controlling the concentration of solvent and adding surfactant and the like.

[0086] A wiring and an electrode are formed by removing an unnecessary portion by etching with the mask 209 (FIG. 3A). Here, wet etching or dry etching can be used. At this time, the semiconductor film 206, the semiconductor film 207 and the conductive metal film 208 are etched to form a semiconductor film 211, a semiconductor film 212 containing one conductivity type impurity element (hereinafter referred to as a semiconductor film 212), and a conductive metal film 213 are formed in a pixel TFT portion. Further, the capacitor wiring 204 and the gate insulating film 205 are left in a capacitor portion and the terminal 202 and the gate insulating film 205 are left in a terminal portion as well.

[0087] Next, a light-transmitting conductive film 214 is formed on the entire surface by ejecting composition containing a conductive material after removing the mask 209 (FIG. 3B). The top plan view here is shown in FIG. 8. However, the light-transmitting conductive film 214 deposited on the entire surface is not shown in FIG. 8 for simplicity.

[0088] In the case of manufacturing a liquid crystal display panel which transmits light, the light-transmitting conductive film 214 may be formed by forming and baking a predetermined pattern by composition containing indium tin oxide (ITO), indium tin oxide containing silicon oxide (ITSO), zinc oxide (ZnO), tin oxide (SnO_2) and the like. Further, in the case of manufacturing a liquid crystal display panel which reflects light, composition containing metal particles of Ag (silver), Au (gold), Cu (copper), W (tungsten), Al (aluminum) and the like can be used. Otherwise, a light-transmitting conductive film or a reflective conductive film may be formed by sputtering, and a mask pattern may be formed by liquid droplet ejection method, to which an etching step may be combined as well.

[0089] Next, a mask 215 is formed by selectively ejecting composition on the light-transmitting conductive film 214. A semiconductor film 216, a source region 217, a drain region 218, a source electrode 219, a drain region 220, and a pixel electrode 221 are formed by removing an unnecessary portion by etching (FIG. 3C).

[0090] Through this etching step, portions of the conductive metal film 213, the semiconductor film 212, and the semiconductor film 211 are simultaneously removed to form an aperture 227 while forming the light-transmitting conductive film 214 at the same time. In this embodiment mode,

a pixel electrode formed of ITO is selectively removed by wet etching using a mixture of nitric acid and hydrochloric acid or ferric chloride solution, and portions of the conductive metal film 213, the semiconductor film 212, and the semiconductor film 211 are etched thereafter. Note that wet etching and dry etching are used in this embodiment mode, however, only dry etching may be performed by appropriately selecting reaction gas or only wet etching may be performed by appropriately selecting reactive solution.

[0091] Further, the aperture 227 reaches the semiconductor film 216, thus the semiconductor film 211 having a depressed portion is formed. By this aperture 227, the metal film 213 is separated into the source electrode 219 and the drain electrode 220, and the semiconductor film 212 is separated into the source region 217 and the drain region 218. The light-transmitting conductive film 228 in contact with the source electrode 219 covers a source wiring connected to the source electrode 219 and prevents electrostatic generated in a subsequent rubbing step, in particular.

[0092] In this embodiment mode, the light-transmitting conductive film 228 is formed on the source wiring, however, the light-transmitting conductive film 214 formed on the source electrode 219 or the source wiring may be removed when the aforementioned ITO film is etched. Moreover, a circuit for protecting from electrostatic may be formed by utilizing the aforementioned ITO film when etching the aforementioned ITO film.

[0093] Through this etching step, the light-transmitting conductive film 214 formed in the terminal portion is removed. Moreover, a storage capacitor is formed of the capacitor wiring 204 and the pixel electrode 221 with the gate insulating film 205 in a capacitor portion as a dielectric.

[0094] Next, a mask is formed by selectively ejecting composition after removing the mask 215. Then, the gate insulating film 205 covering the gate wiring layer 202 in the terminal portion is selectively removed (FIG. 4A). Moreover, a resist mask may be formed by using a screen printing method or a shadow mask instead of the liquid droplet ejection method in which composition is ejected.

[0095] By using the mask selectively formed by ejecting composition in this manner, a pixel TFT portion having an inverted staggered TFT 231 and a storage capacitor 232 can be completed. Then, by forming a pixel portion by arranging these in matrix corresponding to each pixel, one substrate for manufacturing an active matrix liquid crystal display device can be formed. In this specification, such a substrate is referred to as an active matrix substrate for convenience.

[0096] Next, an alignment film 233 is selectively formed only in a pixel portion of the active matrix substrate. The alignment film 233 may be selectively formed by screen printing method or by forming a resist mask using a shadow mask after applying an alignment film, and removing it. An alignment film of a liquid crystal display device is typically formed of polyimide resin. Note that in this embodiment mode, an alignment film is formed after selectively removing the gate insulating film 205 covering the gate wiring layer 202 in the terminal portion, however, the gate insulating film 205 and the alignment film in the terminal portion may be removed simultaneously after forming an alignment film on the gate insulating film 205 covering the gate wiring layer 202 in the terminal portion.

[0097] After that, an insulating film 234 which functions as an alignment film, a counter substrate 236 provided with a conductive film 235 which functions as a counter electrode, and a TFT substrate 200 are attached with a spacer sandwiched therebetween. By providing a liquid crystal layer 237 in the space, a liquid crystal display panel can be manufactured.

[0098] Next, a flexible printed circuit (FPC) is connected to the input terminal 202 of the terminal portion. The FPC is formed of an organic resin film 244 such as polyimide and a copper wiring 243, and connected to the light-transmitting conductive film covering the input terminal with anisotropic conductive adhesive. The anisotropic conductive adhesive is formed by an adhesive 241 and particles 242 having conductive surfaces of several ten to several hundred μm diameters plated with gold and the like mixed therein. With these particles 242 in contact with the light-transmitting conductive film and the copper wiring 243 on the input terminal 202, electrical connections are formed therein. Further, a resin film 245 is provided for enhancing a mechanical strength of this portion. Through the aforementioned steps, a liquid crystal display panel containing a channel-etch type switching TFT and a capacitor is completed (FIG. 4B).

[0099] Note that the light-transmitting conductive film 214 is formed on the gate insulating film 205 in the terminal portion in this embodiment mode (FIG. 3B), however, the gate insulating film 205 covering the input terminal 202 in the terminal portion may be removed before forming the light-transmitting conductive film 214 on the gate wiring layer 202. FIGS. 10A and 10B show steps in this case. Note that the portions corresponding to FIGS. 2A to 2C, 3A to 3C, 4A and 4B are denoted by the same reference numerals.

[0100] As described above, in this embodiment mode, a light exposure step by using a photo mask is unnecessary, therefore, a manufacturing step can be simplified.

Embodiment Mode 2

[0101] In this embodiment mode, a different mode than the aforementioned embodiment mode is described with reference to FIGS. 5A to 5C and 6A and 6B. In Embodiment Mode 1, the semiconductor film 206, the semiconductor film 207 and the metal film 208 are simultaneously etched as shown in FIG. 3A, however, the insulating film 205 may be etched at the same time as well. FIGS. 5A to 5C show steps in this case. Note that steps up to the formation of the metal film 208 may be similar to Embodiment Mode 1, therefore, description thereof is omitted here.

[0102] After the up to FIG. 5A, masks 209 and 309 are formed by selectively ejecting composition on the conductive film 208. Next, a wiring and an electrode are formed by removing an unnecessary portions by etching with the masks 209 and 309 (FIG. 5B), for which wet etching or dry etching is employed. At this time, the insulating film 205, the semiconductor film 206, the semiconductor film 207 and the metal film 208 are etched while an insulating film 305, a semiconductor film 311, a semiconductor film 312 containing impurity elements of one conductivity type, and a conductive metal film 313 are formed in a pixel TFT portion. Further, ends of these films are formed to be approximately the same plane.

[0103] In a capacitor portion, an insulating film 321, a semiconductor film 322, a semiconductor film 323 containing impurity elements of one conductivity type, and a conductive metal film 324 are formed. Similarly, ends of these films approximately correspond to each other.

[0104] The terminal portion is etched leaving the gate wiring layer 202 only. An insulating film on the gate wiring is removed leaving an intersection portion with other wirings. Accordingly, materials of the gate wiring layer 202 and the gate wiring and an insulating film are required to have sufficient selection ratio as well as a material of a terminal and a metal film. That is, the material of the terminal and the gate wiring and the material of the conductive metal film are different.

[0105] Next, a light-transmitting conductive film 325 is formed on the entire surface by ejecting composition containing a conductive material after removing the masks 209 and 309 (FIG. 5C). Subsequently, a mask 326 is formed by selectively ejecting composition on the light-transmitting conductive film 325, thereby a semiconductor film 316, a source region 317 and a drain region 318, a source electrode 319 and a drain region 320, and a pixel electrode 330 are formed by removing unnecessary portions by etching (FIG. 6A).

[0106] Through the aforementioned steps, a liquid crystal display panel shown in FIG. 6B is completed. Note that this embodiment mode can be freely implemented in combination with the aforementioned embodiment mode.

Embodiment Mode 3

[0107] In this embodiment mode, a different mode than the aforementioned embodiment modes is described with reference to FIG. 7. Note that the same portions as those in the aforementioned embodiment modes are denoted by the same reference numerals in FIG. 7.

[0108] First, an insulating film as a protective film is formed after obtaining a state of FIG. 4A according to Embodiment Mode 1. The insulating film is formed by selectively ejecting composition. An insulating film 240 and an insulating film 241 are formed in a pixel TFT portion and a terminal portion respectively. Note that the insulating films 240 and 241 function as passivation films.

[0109] Moreover, an inorganic insulating film such as a silicon oxide film, a silicon nitride film, a silicon oxynitride film, and a tantalum oxide film may be formed in a single layer or a laminated structure. In this case, since a thin inorganic insulating film is formed on the entire surface, the insulating films 240 and 241 are formed by forming a mask by selectively ejecting composition on the insulating film and removing unnecessary portions by etching.

[0110] Thus, an inverted staggered TFT protected by an insulating film is completed without employing a light exposure step using a photo mask.

[0111] Note that this embodiment mode can be freely implemented in combination with the structure of Embodiment Mode 1 or 2.

Embodiment Mode 4

[0112] As Embodiment Mode 4, FIGS. 9A to 9C show the case of forming barrier films on end surfaces of an electrode

and a wiring. In this embodiment mode, a different point than the aforementioned embodiments only is described hereafter since up to the state of FIG. 3A in Embodiment Mode 1 is the same. Further, portions corresponding to FIG. 3A are denoted by the same reference numerals.

[0113] First, the mask 209 is removed after obtaining the state of FIG. 3A according to Embodiment Mode 1. After that, barrier films 280 and 281 are formed on end surfaces of the semiconductor film 211, the semiconductor film 212 containing impurity elements of one conductivity type, and the metal film 213 by selectively ejecting composition.

[0114] The barrier films 280 and 281 are formed of a resin material such as a known conductive material, epoxy resin, acryl resin, phenol resin, novolac resin, melamine resin, and urethane resin. In the case of employing these resin materials, the viscosity thereof is preferably controlled by dissolving or dispersing by using solvent. Further, lyophobic resin is preferably used such as resin containing a fluoride atom or resin formed only of carbon hydride. More specifically, resin containing monomer including a fluoride atom in a molecular or resin containing monomer formed only of carbon and hydrogen atoms are used. Note that in the case of forming the barrier films by a conductive material, it is required to be formed so as not to short-circuit with a wiring. Therefore, the barrier films are preferably formed of resin material in a region that possibly short-circuits with a wiring. Further, there may be a break when forming the barrier films depending on a slope of the end surfaces. In order to prevent the break, one or a plurality of drops are baked after ejection for solidifying the composition, that is, ejection and baking are preferably performed repeatedly.

[0115] In general, a step is formed when a laminated structure of the semiconductor film 206, the semiconductor film 207 and the metal film 208 is simultaneously etched to form a pattern. Therefore, by forming barrier films on end surfaces of the semiconductor film 211, the semiconductor film 212 and the metal film 213, a break can be prevented when forming a light-transmitting conductive film. The barrier film is formed by controlling a quantity of ejection according to position so that a step of an end surface can be planarized.

[0116] As described in this embodiment mode, by providing barrier films on a portion having a step by selectively ejecting composition, a break can be prevented, thus the production yield can be improved. Further, a method described in this embodiment mode can be used to any portions as long as there is a step.

[0117] Note that this embodiment mode can be freely implemented in combination with the structures of Embodiment Modes 1 to 3.

Embodiment Mode 5

[0118] In Embodiment Mode 1, an insulating film, a first amorphous semiconductor film, a second amorphous semiconductor film containing impurity elements which impart N-type or P-type, and a first conductive film are sequentially laminated successively. FIG. 13 shows an example of an apparatus provided with a plurality of chambers used in the case of depositing sequentially in this manner.

[0119] FIG. 13 shows a schematic diagram of an apparatus (continuous deposition system) described in this embodi-

ment seen from the top. In FIG. 13, reference numerals 10 to 15 denote chambers each having air tightness. Each of the chambers is provided with a vacuum evacuation pump and an inert gas inlet system.

[0120] The chambers denoted by 10 and 15 are load lock chambers for transferring a sample (processing substrate) 30 into the system. The chamber denoted by 11 is a first chamber for depositing an insulating film 104. The chamber denoted by 12 is a second chamber for depositing a first amorphous semiconductor film 105. The chamber denoted by 13 is a third chamber for depositing a second amorphous semiconductor film 106 which imparts N-type. The chamber denoted by 14 is a fourth chamber for depositing a first conductive film 107. Further, a chamber commonly provided for each chamber is a common chamber denoted by 20.

[0121] First, all the chambers are evacuated to a high vacuum and then purged with an inert gas which is nitrogen here (at normal pressure). Moreover, all gate valves 22 to 27 are closed.

[0122] First, a cassette 28 storing a number of processing substrates is transferred into the load lock chamber 10. After the transfer of the cassette 28, a door of the load lock chamber 10 which is not shown is closed. In this state, one processing substrate 30 is taken out of the cassette 28 by opening the gate valve 22, and then transferred to the common chamber 20 by a robot arm 21. At this time, an alignment is performed in the common chamber 20. Note that the wirings 202, 203 and 204 are formed on the substrate 30 that are obtained according to Embodiment Mode 1.

[0123] Here, the gate valve 22 is closed and the gate valve 23 is opened. Then, the processing substrate 30 is transferred to the first chamber 11. The processing substrate 30 is applied a film deposition process at 150 to 300° C. in the first chamber, thereby the gate insulating film 205 is obtained. Note that the insulating film may be a silicon nitride film, a silicon oxide film, a silicon nitride oxide film, or a lamination of these films. In this embodiment mode, a single layer of silicon nitride film is used, however, a lamination of two, three or more layers may be used as well. Note that the chamber that plasma CVD can be performed is used here, however, a chamber that sputtering by using a target can be performed may be used as well.

[0124] After depositing the insulating film, the processing substrate is taken out to the common chamber by the robot arm and transferred to the second chamber 12. In the second chamber 12, a film deposition process is applied at 150 to 300° C. similarly to the first chamber 11 and the first amorphous semiconductor film 105 is obtained by plasma CVD. Note that the first amorphous semiconductor film may be a micro crystal semiconductor film, an amorphous germanium film, an amorphous silicon germanium film, or a lamination of these films. Further, thermal treatment for reducing a hydrogen concentration may be omitted by setting a temperature for forming the first amorphous semiconductor film at 350 to 500° C. Note that the chamber that plasma CVD can be performed is used here, however, a chamber that sputtering by using a target can be performed may be used as well.

[0125] After depositing the first amorphous semiconductor film 105, the processing substrate is taken out to the

common chamber and transferred to the third chamber 13. In the third chamber 13, a film deposition process is applied at 150 to 300° C. similarly to the second chamber 12 and the second amorphous semiconductor film 106 containing impurity elements (P or As) which impart N-type is obtained by plasma CVD. Note that the chamber that plasma CVD can be performed is used here, however, a chamber that sputtering by using a target can be performed may be used as well.

[0126] After depositing the second amorphous semiconductor film 106 containing impurity elements which impart N-type, the processing substrate is taken out to the common chamber and transferred to the fourth chamber 14. In the fourth chamber 14, the first conductive film 107 is obtained by sputtering by using a metal target. Note that the first conductive film may be formed by ejecting composition containing a conductive material as described in Embodiment Mode 1, which can be selected by a practitioner appropriately.

[0127] The processing substrate sequentially deposited with four layers is transferred to the load lock chamber 15 by the robot arm and stored in the cassette 29.

[0128] It is needless to say that the apparatus shown in FIG. 13 is only an example. Further, this embodiment can be freely implemented in combination with any one of Embodiment Modes 1 to 4.

Embodiment Mode 6

[0129] In Embodiment Mode 6, a different mode than Embodiment Mode 5 is described with reference to FIG. 14. Specifically, a plurality of chambers are used to laminate films sequentially in Embodiment Mode 5, however, only one chamber is used for sequentially laminating layers while keeping the high vacuum therein by using the apparatus shown in FIG. 14.

[0130] In this embodiment mode, a system shown in FIG. 14 is used. In FIG. 14, reference numeral 40 denotes a processing substrate, 50 denotes a common chamber, 44 and 46 denote load lock chambers, 45 denotes a chamber, and 42 and 43 denote cassettes. In this embodiment mode, the same chamber is used for laminating layers in order to prevent contamination generated when the substrate is transferred.

[0131] This embodiment mode can be freely implemented in combination with any one of Embodiment Modes 1 to 4.

[0132] For example, in the case of applying to Embodiment Mode 1, a plurality of targets are provided in the load lock chamber 45. Then, by exchanging reaction gas sequentially, the insulating film 205, the first amorphous semiconductor film 206, the second amorphous semiconductor film 207 containing impurity elements which impart N-type, and the first conductive film 208 are laminated.

Embodiment Mode 7

[0133] In this embodiment mode, an example of applying the invention to a reflective liquid crystal display device is described with reference to FIG. 12.

[0134] First, a substrate 700 having an insulating surface is prepared. The substrate 700 may be a non-alkali glass substrate such as a barium borosilicate glass, an aluminoborosilicate glass, and an aluminosilicate glass which are

formed by fusion method and float method, a ceramic substrate, a plastic substrate which can resist the processing temperature during this step and the like. Further, a semiconductor substrate formed of single crystalline silicon and the like and a substrate provided with an insulating layer on the surface of a metal substrate such as stainless can be applied as well.

[0135] Next, a gate wiring **701** and a projection portion **702** are formed by selectively ejecting composition containing a conductive material on the substrate **700**. The projection portion is provided in a region surrounded by a gate wiring and a source wiring, that is a display region in which pixel electrodes are formed. Note that the shape of the projection portion **702** is not particularly limited and its sectional surface in a diametrical direction may be polygonal or in an asymmetrical shape. For example, the projection portion **702** may have a columnar, prism, cone, or pyramid shape. Further, the projection portion **702** may be arranged regularly or irregularly.

[0136] Next, a gate insulating film **703** is formed in a single layer or laminated structure by plasma CVD or sputtering. The insulating film **703** is formed on a substrate on which a projection portion is formed and has projections and depressions on the surface.

[0137] Subsequently, a first semiconductor film, a second semiconductor film containing impurity elements, and a first conductive film are sequentially formed in lamination.

[0138] The first semiconductor film is formed of an AS or an SAS by vapor deposition or sputtering using semiconductor gas typified by silane and germane. The second semiconductor film containing impurity elements may be formed by using silane gas and phosphine gas and can be formed of an AS or an SAS.

[0139] Next, a mask is formed on the first conductive film by selectively ejecting composition, then the first semiconductor film, the second semiconductor film and the first conductive film are etched by using the mask. Thus, the first semiconductor film, the second semiconductor film and the first conductive film are patterned respectively.

[0140] After that, the second conductive film is formed on the entire surface by using a known method. Note that the second conductive film is formed by using a reflective conductive film. Further, the second conductive film may be formed by ejecting a conductive material.

[0141] Next, a mask is formed on the second conductive film by selectively ejecting composition, then a portion which is not covered with the mask is etched to form a semiconductor film **716**, a source region **717**, a drain region **718**, a source electrode **719**, a drain electrode **720**, and a pixel electrode **705**.

[0142] Thus, the insulating film formed on the projection portion **702** has projections and depressions on the surface. As the pixel electrode **705** is formed on the insulating film **703** having projections and depressions on the surface, the pixel electrode **705** can have projections and depressions on the surface, which scatters light.

[0143] According to this embodiment mode, a mask can be formed by selectively ejecting composition when forming a pixel TFT portion, which can omit a light exposure step using a photo mask. Conventionally, a step was required to

be increased for forming projection and depression, however, projection is formed at the same time as the gate line by ejecting composition in this embodiment mode. Therefore, projection and depression can be formed on a pixel electrode without an additional step.

Embodiment Mode 8

[0144] In this embodiment mode, a simplified step for manufacturing an active matrix substrate in Embodiment Mode 1 is described with reference to FIGS. **11A** to **11C**.

[0145] First, the gate wiring layer **202**, the gate electrode layer **203**, and the capacitor wiring layer **204** are formed on the substrate **200** by selectively ejecting composition containing a conductive material. Next, the gate insulating film **205** is formed in a single layer or a laminated structure by plasma CVD or sputtering. Further, the semiconductor film **206** as an active layer and the N-type or P-type semiconductor film **207** as a semiconductor containing impurity elements of one conductivity type are formed. The aforementioned steps are similar to Embodiment Mode 1, therefore, a detailed description is omitted here.

[0146] Next, a conductive metal film **508** is formed on the semiconductor film **207** by selectively ejecting a conductive composition (FIG. **11A**). The metal film **508** can be formed of a conductive composition containing metal particles such as Ag, Au, Cu, W, and Al as its main component. Further, indium tin oxide which transmits light, ITSO formed of indium tin oxide and silicon oxide, organic indium, organic tin, zinc oxide, titanium nitride and the like may be used in combination as well.

[0147] Next, the semiconductor films **206** and **207** which are not covered with the metal film **508** are etched with the metal film **508** as a mask, thereby a semiconductor film **511** and an N-type semiconductor film **512** are formed in a pixel TFT portion (FIG. **11B**). Note that either of wet etching or dry etching may be used here, however, a method that does not corrode the metal film **508** is preferable.

[0148] Next, a light-transmitting conductive film **514** is formed on the entire surface by ejecting composition containing a conductive material, and then a mask **515** is formed by selectively ejecting composition. By etching with this mask **515**, a semiconductor film **516**, a source region **517**, a drain region **518**, a source electrode **519**, a drain electrode **520**, and a pixel electrode **521** are formed.

[0149] According to this embodiment mode, steps for forming a mask and removing the mask after etching are no longer required by selectively forming the metal film **508** and using it as a mask. Thus, a liquid crystal display panel can be formed by simpler steps.

Embodiment Mode 9

[0150] Next, a mode for mounting a driver circuit on a liquid crystal display panel formed according to the aforementioned embodiment mode is described with reference to FIGS. **17A**, **17B**, **18A**, **18B**, **19A** and **19B**.

[0151] First, a description is made on a display device using COG with reference to FIGS. **17A** and **17B**. A pixel portion **1002** for displaying data such as text and an image, driver circuits **1003** and **1004** on a scan side and the like are provided on a substrate **1001**. Substrates **1005** and **1008**

provided with a plurality of driver circuits are divided into rectangular shapes and the divided driver circuits (hereinafter referred to as driver ICs) are mounted on the substrate **1001**. FIG. **17A** shows a mode for mounting a plurality of driver ICs **1007** of which ends are attached with tapes **1006**. FIG. **17B** shows a mode for mounting a driver IC **1010** of which ends are attached with tapes **1009**.

[**0152**] Next, a description is made on a display device using TAB with reference to FIGS. **18A** and **18B**. The pixel portion **1002**, the driver circuits **1003** and **1004** on a scan side are provided on the substrate **1001**. FIG. **18A** shows a mode for attaching the tapes **1006** on the substrate **1001** and mounting driver ICs on the tapes **1006**. FIG. **18B** shows a mode for attaching the tape **1009** on the substrate **1001** and mounting the driver IC **1010** on the tape **1009**. In the latter case, a metal piece for fixing the driver IC **1010** is preferably provided together for reinforcement.

[**0153**] It is preferable that these driver ICs mounted on a liquid crystal display device are formed in a plurality of numbers on the substrates **1005** and **1008** of which one side is 300 to 1000 mm or more in view of improving the productivity.

[**0154**] That is, a circuit pattern having a driver circuit portion and input and output terminals as one unit is formed in a plurality of numbers on the substrates **1005** and **1008** and may be divided to be separated. The long side of the driver IC may be determined in consideration of the length of one side of a pixel portion and a pixel pitch. The driver IC may have a rectangular shape of which long side is 15 to 80 mm and the short side is 1 to 6 mm as shown in FIGS. **17A** and **18A**. Alternatively, the driver IC may have a long side as long as one side of the pixel region **1002**, or a length that added one side of the pixel portion **1002**, and one sides of the driver circuits **1003** and **1004**.

[**0155**] As shown in FIGS. **17A**, **17B**, **18A**, and **18B**, by forming driver ICs on a glass substrate, a long side in particular is not restricted in length, therefore, only a small number is required for mounting corresponding to the pixel portion **1002**. That is, a driver IC formed of single crystalline silicon cannot be formed long due to a mechanical strength and depending on a substrate. By forming a driver IC on a glass substrate, shape of a mother substrate is not restricted, therefore, productivity is not decreased. This is a significant advantage as compared to the case of taking IC chips out of a circular silicon wafer.

[**0156**] In FIGS. **17A**, **17B**, **18A**, and **18B**, a driver IC **1007**, **1008**, or **1009** each having a driver circuit is mounted in an external region of the pixel region **1002**. These driver ICs **1007** to **1009** are driver circuits on a signal line side. In order to form a pixel region corresponding to an RGB full color display, 3072 signal lines are required in XGA and 4800 signal lines are required in UXGA. The signal lines formed in such numbers are divided per few blocks at the end portion of the pixel region **1002** to obtain lead wirings, then gathered according to a pitch of output terminals of the driver ICs **1007** to **1009**.

[**0157**] It is preferable that the driver IC is formed of a crystalline semiconductor formed on a substrate. The crystalline semiconductor is preferably formed by continuous laser irradiation. Therefore, a solid state laser or a gas laser of continuous oscillation is used for generating the laser

light. With the continuous oscillation laser, a transistor can be formed by using a polycrystalline semiconductor layer having large grains with less crystal defects. Moreover, as mobility and response are good, high-speed drive can be performed, which results in improving the operation frequency of elements than the conventional one. Therefore, a high reliability can be obtained because of less variation in characteristics. It is preferable that a direction of channel length of a transistor and a scanning direction of the laser light to the substrate are the same in order to further improve operation frequency. In a laser crystallization step by using a continuous oscillation laser, the highest mobility can be obtained when the direction of a channel length of a transistor and a scanning direction of a laser light against the substrate are approximately parallel to each other (more preferably -30 to 30°). The direction of channel length is a direction of current flow in a channel formation region, that is a direction that a charge moves in other words. A transistor manufactured in this manner has an active layer formed of a polycrystalline semiconductor layer of which crystal grains extend in a direction of a channel, which implies that crystal grain boundary is formed approximately along the direction of the channel.

[**0158**] In order to perform laser crystallization, it is preferable that the laser light be sharply focused to have a beam width of 1 to 3 mm approximately which is as long as a short side of the driver IC. Further, it is preferable that the irradiation region of laser light be linear in order to secure a sufficient and effective energy density. However, linear here does not mean a line in the strict sense but means a large rectangle or an oblong having a large aspect ratio, for example, the one having two or more of aspect ratio (more preferably 10 to 10000). In this manner, when a width of a beam spot of a laser light is as long as a short side of a driver IC, a manufacturing method of a display device of which productivity is improved can be provided.

[**0159**] In FIGS. **17A**, **17B**, **18A**, and **18B**, scan line driver circuits and a pixel portion are integrally formed, and a driver IC is mounted as a signal line driver circuit. However, the invention is not limited to this mode and driver ICs may be mounted as both of the scan line driver circuit and the signal line driver circuit. In that case, driver ICs having different specifications are preferably used on a scan line side and a signal line side.

[**0160**] In the pixel region **1002**, signal lines and scan lines cross each other to form a matrix and transistors are disposed corresponding to each intersection portion. According to the invention, a TFT of which channel portion is formed of amorphous semiconductor or semi-amorphous semiconductor are used as transistors disposed in the pixel portion **1002**. The amorphous semiconductor is formed by plasma CVD, sputtering and the like. The semi-amorphous semiconductor can be formed by plasma CVD at 300° C. or lower. A non-alkali glass substrate having a size of 550×650 mm, for example, can be formed in a thickness required for forming transistors in a short time. Such features of a manufacturing technology are efficient in manufacturing a display device having a large display. Moreover, by forming a channel formation region by an SAS, the semi-amorphous TFT can obtain electric field mobility of 2 to $10 \text{ cm}^2/\text{V sec}$. Therefore, this TFT can be used as a switching element in a pixel and an element which constitutes a driver circuit on a scan

line side. Therefore, a liquid crystal display panel that realizes system on panel can be manufactured.

[0161] Note that by using a TFT of which semiconductor layer is formed of an SAS, a scan line driver circuit is integrally formed on a substrate as well in FIGS. 17A, 17B, 18A and 18B. In the case of using a TFT of which semiconductor layer is formed of AS, driver ICs may be mounted as both of the scan line driver circuit and the signal line driver circuit.

[0162] In that case, it is preferable that the driver ICs having different specifications are used on the scan line side and the signal line side. For example, a transistor which constitutes the driver IC on the scan line side is required withstand a pressure of 30 V approximately, whereas a driving frequency thereof is 100 kHz or less and a high speed operation is not so much required. Therefore, it is preferable that a channel length (L) of a transistor which constitutes a scan line driver is long enough. On the other hand, a transistor which constitutes the driver IC on the signal line side is required to withstand a pressure of only about 12 V, whereas a driving frequency is about 65 MHz with 3 V and a high speed operation is required. Therefore, it is preferable that a channel length of the transistor which constitutes the driver and the like are set by using micron rule.

[0163] FIGS. 19A and 19B show structures for mounting a driver IC by COG. FIG. 19A shows a structure that a driver IC 806 is mounted on a TFT substrate 800 by using anisotropic conductive material. A pixel region 801 and an input terminal 804 on a signal line side (an input terminal on a scan line side is similar) are provided on the TFT substrate 800. A counter substrate 829 is adhered to the TFT substrate 800 with a sealing material 826, sandwiching a liquid crystal layer 830.

[0164] An FPC 812 is adhered to the input terminal 804 on the signal line side by anisotropic conductive material. The anisotropic conductive material is formed of resin 815 and conductive particles 814 of which diameter is tens to hundreds μm of which surface is plated with Au and the like. The signal line input terminal 104 and the wiring 813 formed on the FPC 812 are electrically connected through the conductive particles 814. The driver IC 806 is adhered on the TFT substrate 800 by anisotropic conductive material and input and output terminals 809 provided on the driver IC 806 and the input terminal 804 on the signal line side are electrically connected through conductive particles 810 mixed in resin 811.

[0165] Further, as shown in FIG. 19B, the driver IC 806 may be fixed on the TFT substrate 800 with an adhesive 816, and input and output terminals of the driver IC and a lead wiring or a connecting wiring may be connected by an Au wire 817. Then, sealing resin 818 is used for sealing. Note that a mounting method of the driver IC is not particularly limited and a known COG, wire bonding, or TAB can be used as well.

[0166] With the driver IC being as thick as a counter substrate, a height of the space between them becomes approximately the same and a display device as a whole can be formed thin. Further, by forming each substrate by using the same material, a thermal stress is not generated even when a temperature of the display device changes, thus the

characteristics of a circuit formed of TFTs are not damaged. Moreover, by mounting a driver circuit of a driver IC which is longer than an IC chip as shown in this embodiment mode, the number of driver ICs to be mounted in one pixel region can be reduced.

[0167] As described above, a driver circuit can be incorporated in a liquid crystal display panel.

Embodiment Mode 10

[0168] With a liquid crystal display panel manufactured according to Embodiment Mode 9, a liquid crystal television receiver can be completed. FIG. 23 is a block diagram showing a major structure of a liquid crystal television receiver. In the liquid crystal display panel, a pixel portion 401 only is formed and a scan line driver circuit 403 and a signal line driver circuit 402 are mounted by TAB as shown in FIG. 20, or the scan line driver circuit 403 and the signal line driver circuit 402 are mounted on the periphery of the pixel portion 401 by COG as shown in FIG. 21. Otherwise, a TFT is formed of an SAS, the pixel portion 401 and the scan line driver circuit 403 are integrally formed on a substrate, and the signal line driver circuit 402 is mounted as a driver IC as shown in FIG. 22. The invention can employ any of these modes.

[0169] As other external circuits, an image signal amplifier circuit 405 which amplifies image signals among the signals received by a tuner 404, an image signal processing circuit 406 which converts the outputted signals to color signals corresponding to each of red, green and blue, a control circuit 407 which converts the image signals for inputting to a driver IC, and the like are provided. The control circuit 407 outputs signals to the scan line side and the signal line side. When performing a digital drive, a signal dividing circuit 408 is provided on the signal line side to divide input digital signals into m-pieces to be supplied.

[0170] Among the signals received by the tuner 404, an audio signal is sent to an audio signal amplifier circuit 409 and the outputted signal is supplied to a speaker 413 through an audio signal processing circuit 410. The control circuit 411 receives data of a receiving station (receiving frequency) and audio control from an input portion 412 and send them to the tuner 404 and the audio signal processing circuit 410.

[0171] FIG. 24 is an example of a liquid crystal display module in which a TFT substrate 200 and a counter substrate 229 are fixed by a sealing material 226, sandwiching the pixel portion 101 and the liquid crystal layer 230 to form a display region. A colored layer 250 is required for performing a color display. In the case of an RGB method, a colored layer corresponding to each of red, green and blue is provided for each pixel correspondingly. Polarizers 251 and 252 are provided outside of the TFT substrate 200 and the counter substrate 229. A light source is constituted by a cold cathode tube 258 and a light guide 259. A circuit substrate 257 is connected to the TFT substrate 200 by a flexible wiring substrate 256 and incorporated with external circuits such as a control circuit and a power source circuit.

[0172] FIG. 25 shows a television receiver completed by incorporating the aforementioned liquid crystal display module in a housing 2301. A display screen 2303 is completed by the liquid display module and provided with

speakers **2304**, an operating switch **2305** and the like as accessory equipment. In this manner, a television receiver can be completed according to the invention.

[**0173**] It is needless to say that the invention is not limited to a television receiver and can be used in various applications in particular as a large display medium such as a monitor of a personal computer, an information display in train stations, airports and the like, advertisement display on the streets.

[**0174**] This application is based on Japanese Patent Application serial no. 2003-386013 filed in Japan Patent Office on Nov. 14, 2003, the contents of which are hereby incorporated by reference.

1. A liquid crystal display device comprising:

a gate electrode formed on an insulating surface;

a semiconductor film formed on the gate electrode sandwiching an insulating film;

a source region and a drain region formed on the semiconductor film;

a barrier film formed so as to cover at least portions of ends of the source electrode formed on the source region, a drain electrode formed on the drain region, and the source electrode and the drain electrode; and

a pixel electrode formed so as to cover the drain electrode and the barrier film,

wherein at least a portion of an end surface of the source region approximately corresponds to an end surface of the semiconductor film and an end surface of the source electrode; and

wherein at least a portion of an end surface of the drain region approximately corresponds to an end surface of the semiconductor film and an end surface of the drain electrode.

2. A liquid crystal display device comprising:

a gate electrode formed on an insulating surface;

a semiconductor film formed on the gate electrode sandwiching an insulating film;

a source region and a drain region formed on the semiconductor film;

a barrier film formed so as to cover at least portions of ends of the source electrode formed on the source region, a drain electrode formed on the drain region, and the source electrode and the drain electrode; and

a pixel electrode formed so as to cover the drain electrode and the barrier film,

wherein one end surface of the drain region approximately corresponds to an end surface of the semiconductor film and an end surface of the drain electrode and the other end surface approximately corresponds to an end surface of the pixel electrode and the other end surface of the drain electrode.

3. The liquid crystal display device according to claim 1,

wherein the pixel electrode is formed of a light-transmitting conductive film.

4. The liquid crystal display device according to claim 2, wherein the pixel electrode is formed of a light-transmitting conductive film.

5. The liquid crystal display device according to claim 1, wherein the pixel electrode is formed of a conductive film containing Ag (silver), Au (gold), Cu (copper), W (tungsten), and Al (aluminum) as its main component, or a lamination thereof.

6. The liquid crystal display device according to claim 2, wherein the pixel electrode is formed of a conductive film containing Ag (silver), Au (gold), Cu (copper), W (tungsten), and Al (aluminum) as its main component, or a lamination thereof.

7. The liquid crystal display device according to claim 1, wherein the semiconductor film is a semi-amorphous semiconductor containing hydrogen and halogen element, and a crystalline structure.

8. The liquid crystal display device according to claim 2, wherein the semiconductor film is a semi-amorphous semiconductor containing hydrogen and halogen element, and a crystalline structure.

9. A method for manufacturing a liquid crystal display device comprising:

forming a gate electrode by selectively ejecting composition on an insulating surface;

forming an insulating film so as to cover the gate electrode;

forming a first semiconductor film on the insulating film;

forming a second semiconductor film containing an impurity element which imparts N-type or P-type on the first semiconductor film;

forming a first conductive film on the second semiconductor film;

forming a pattern of laminated films of the first semiconductor film, the second semiconductor film and the first conductive film by selectively removing the first semiconductor film, the second semiconductor film and the first conductive film by using a first mask;

forming a second conductive film so as to cover the laminated films; and

forming a source region and a drain region formed of the second semiconductor film, a source electrode and a drain electrode formed of the first conductive film, and a pixel electrode formed of the second conductive film by selectively removing a portion of the first semiconductor film, the second semiconductor film, the first conductive film and the second conductive film.

10. A method for manufacturing a liquid crystal display device comprising:

forming a gate electrode by selectively ejecting composition on an insulating surface;

forming an insulating film so as to cover the gate electrode;

forming a first semiconductor film on the insulating film;

- forming a second semiconductor film containing an impurity element which imparts N-type or P-type on the first semiconductor film;
- forming a first conductive film on the second semiconductor film;
- forming a pattern of laminated films of the first semiconductor film, the second semiconductor film and the first conductive film by selectively removing the first semiconductor film, the second semiconductor film and the first conductive film by using a first mask;
- forming a barrier film by selectively ejecting composition on an end surface of the laminated films;
- forming a second conductive film so as to cover the laminated films and the barrier film; and
- forming a source region and a drain region formed of the second semiconductor film, a source electrode and a drain electrode formed of the first conductive film, and a pixel electrode formed of the second conductive film by selectively removing a portion of the first semiconductor film, the second semiconductor film, the first conductive film and the second conductive film.
- 11.** The method for manufacturing a liquid crystal display device according to claim 9;
- wherein the insulating film, the first semiconductor film, the second semiconductor film and the first conductive film are formed sequentially without being exposed to atmosphere.
- 12.** The method for manufacturing a liquid crystal display device according to claim 10;
- wherein the insulating film, the first semiconductor film, the second semiconductor film and the first conductive film are formed sequentially without being exposed to atmosphere.
- 13.** A method for manufacturing a liquid crystal display device according to claim 9,
- wherein the first mask and the second mask are formed by selectively ejecting composition.
- 14.** A method for manufacturing a liquid crystal display device according to claim 10,
- wherein the first mask and the second mask are formed by selectively ejecting composition.
- 15.** The method for manufacturing a liquid crystal display device according to claim 9,
- wherein the second conductive film is formed by selectively ejecting composition.
- 16.** The method for manufacturing a liquid crystal display device according to claim 10,
- wherein the second conductive film is formed by selectively ejecting composition.
- 17.** A method for manufacturing a liquid crystal display device comprising:
- forming a gate electrode by selectively ejecting composition on an insulating surface;
- forming an insulating film so as to cover the gate electrode;
- forming a first semiconductor film on the insulating film;
- forming a second semiconductor film containing an impurity element which imparts N-type or P-type on the first semiconductor film;
- forming a first conductive film on the second semiconductor film;
- forming a pattern of laminated films of the first semiconductor film, the second semiconductor film and the first conductive film by selectively removing the first semiconductor film, the second semiconductor film and the first conductive film by using a first mask; and
- forming a source region and a drain region formed of the second semiconductor film, a source electrode and a drain electrode formed of the first conductive film, and a pixel electrode formed of the second conductive film by selectively removing a portion of the first semiconductor film, the second semiconductor film, the first conductive film and the second conductive film by using a mask.

* * * * *

专利名称(译)	液晶显示装置及其制造方法		
公开(公告)号	US20070040971A1	公开(公告)日	2007-02-22
申请号	US10/577058	申请日	2004-11-05
[标]申请(专利权)人(译)	株式会社半导体能源研究所		
申请(专利权)人(译)	半导体能源研究所有限公司.		
当前申请(专利权)人(译)	半导体能源研究所有限公司.		
[标]发明人	MAEKAWA SHINJI YAMAZAKI SHUNPEI KUWABARA HIDEAKI MORIYA YOSHITAKA		
发明人	MAEKAWA, SHINJI YAMAZAKI, SHUNPEI KUWABARA, HIDEAKI MORIYA, YOSHITAKA		
IPC分类号	G02F1/1333 G02F1/136 G02F1/1368 H01L21/288		
CPC分类号	G02F1/1368 H01L2924/181 H01L2224/16225 H01L2224/32225 H01L2224/48091 H01L2224/48227 H01L2224/48464 H01L2224/73204 H01L2224/73265 H01L2924/00014 H01L2924/00012 H01L2924/00		
优先权	2003386013 2003-11-14 JP		
其他公开文献	US7499117		
外部链接	Espacenet USPTO		

摘要(译)

通过在液晶显示装置的制造步骤中使用一个光掩模，诸如抗蚀剂涂覆，预烘烤，曝光，显影和后烘烤的步骤，以及覆盖膜的形成，蚀刻，抗蚀剂剥离，漂洗，干燥和需要在上述步骤之前和之后使用，这使得该过程复杂化。为了解决该问题，采用沟道蚀刻型底栅TFT（反交错TFT）来图案化源区和漏区以及具有相同掩模的像素电极。此外，根据本发明，在形成诸如用于布线层或电极的导电层的液晶显示装置，用于形成预定图案的掩模等所需的图案中，它们中的至少一个或多个是通过可选择性地形成图案的方法形成，从而制造液晶显示装置。

