



US007561219B2

(12) **United States Patent**
Seo et al.

(10) **Patent No.:** **US 7,561,219 B2**
(45) **Date of Patent:** **Jul. 14, 2009**

(54) **FABRICATION METHOD OF A LIQUID CRYSTAL DISPLAY DEVICE USING SMALL MOLECULE ORGANIC SEMICONDUCTOR MATERIAL**

(75) Inventors: **Hyun-Sik Seo**, Anyang-si (KR);
Seung-Han Paek, Incheon (KR);
Nack-Bong Choi, Suwon-si (KR)

(73) Assignee: **LG Display Co., Ltd.**, Seoul (KR)

(*) Notice: Subject to any disclaimer, the term of this patent is extended or adjusted under 35 U.S.C. 154(b) by 470 days.

(21) Appl. No.: **11/168,365**

(22) Filed: **Jun. 29, 2005**

(65) **Prior Publication Data**
US 2006/0061702 A1 Mar. 23, 2006

(30) **Foreign Application Priority Data**
Sep. 22, 2004 (KR) 10-2004-0075984

(51) **Int. Cl.**
G02F 1/136 (2006.01)
H01L 21/00 (2006.01)
H01L 35/24 (2006.01)

(52) **U.S. Cl.** **349/43**; 438/149; 438/151;
438/161; 257/40

(58) **Field of Classification Search** 349/43;
438/149, 151, 161; 257/40
See application file for complete search history.

(56) **References Cited**

U.S. PATENT DOCUMENTS

5,751,020 A 5/1998 Lyu
6,197,663 B1* 3/2001 Chandross et al. 438/455

6,207,472 B1* 3/2001 Callegari et al. 438/99
7,186,634 B2* 3/2007 Yoneya 438/597
7,241,652 B2* 7/2007 Park et al. 438/197
2002/0012080 A1* 1/2002 Ishihara et al. 349/43
2002/0043662 A1* 4/2002 Yamazaki et al. 257/72
2003/0160235 A1* 8/2003 Hirai 257/40
2004/0023447 A1* 2/2004 Hirakata et al. 438/149

FOREIGN PATENT DOCUMENTS

CN 1333475 A 1/2002
CN 1522470 A 8/2004

OTHER PUBLICATIONS

Scott, James F. et al., "Ferroelectric Memories," Science, vol. 246, No. 4936, Dec. 15, 1989, pp. 1400-1405.

* cited by examiner

Primary Examiner—Andrew Schechter

Assistant Examiner—Charles Chang

(74) *Attorney, Agent, or Firm*—Birch, Stewart, Kolasch & Birch, LLP

(57) **ABSTRACT**

A liquid crystal display structure is provided. The liquid crystal display structure includes a pixel region and a thin film transistor on the substrate. The thin film transistor is adjacent to the pixel region and includes a gate electrode; a gate insulating layer having a top surface; a source electrode and a drain electrode at the top surface of the gate insulating layer; a semiconductor layer disposed at the top surface of the gate insulating layer, the semiconductor layer between the source electrode and the drain electrode defining a channel region, the semiconductor layer including a small molecule organic semiconductor material; and a first passivation layer covering the channel region, a top surface of the first passivation layer coinciding with or being below a top surface of each of the source electrode and the drain electrode.

12 Claims, 17 Drawing Sheets

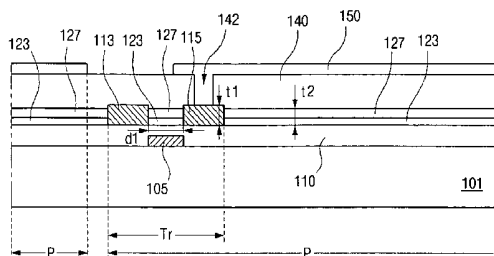
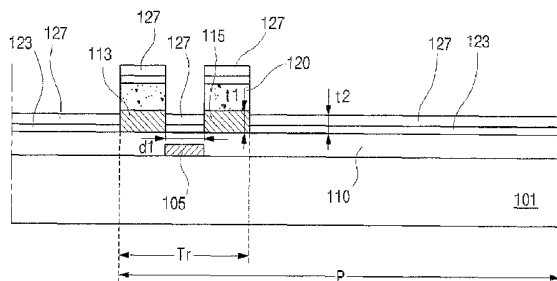

FIG. 1
(related art)

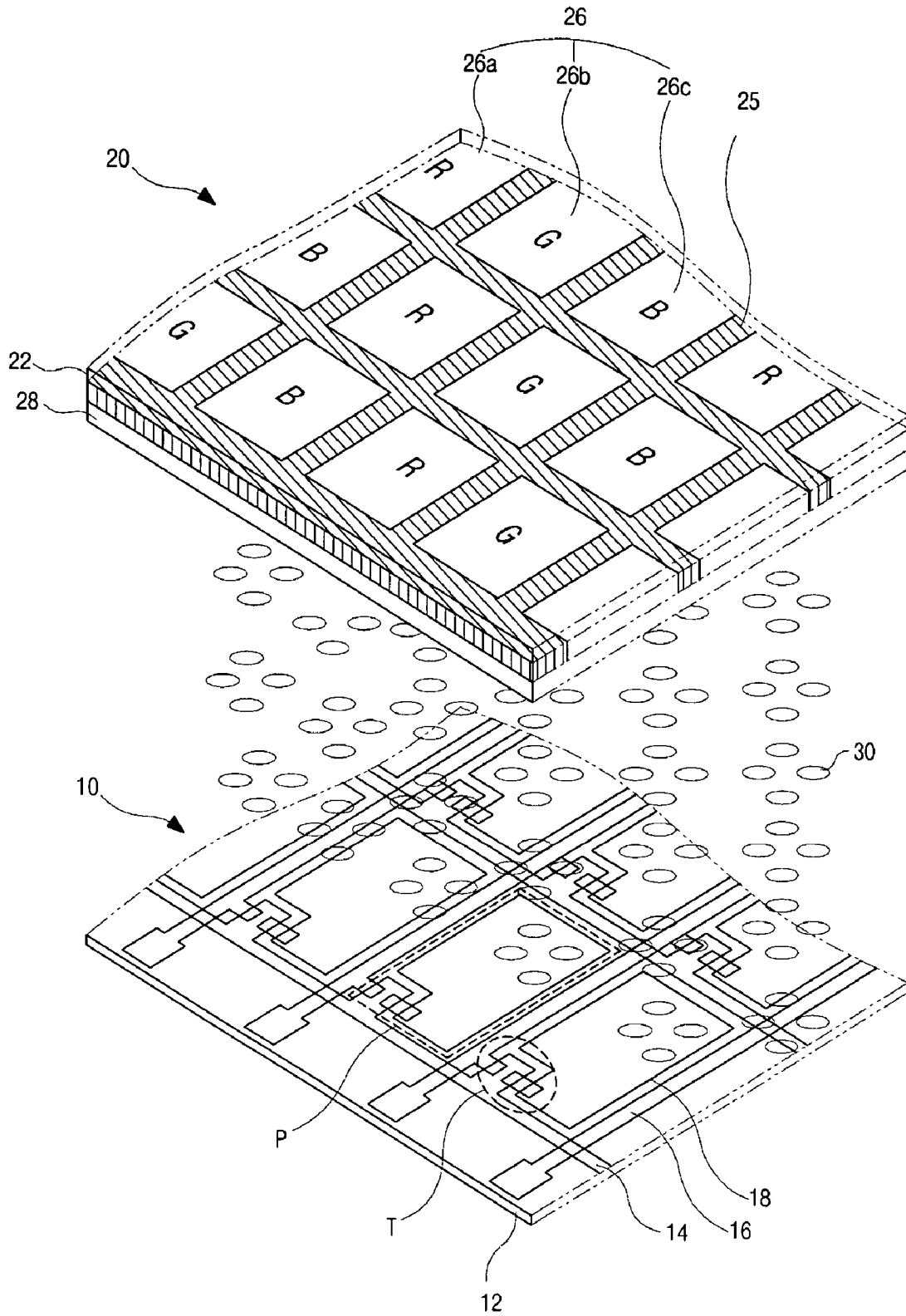

FIG. 2
(related art)

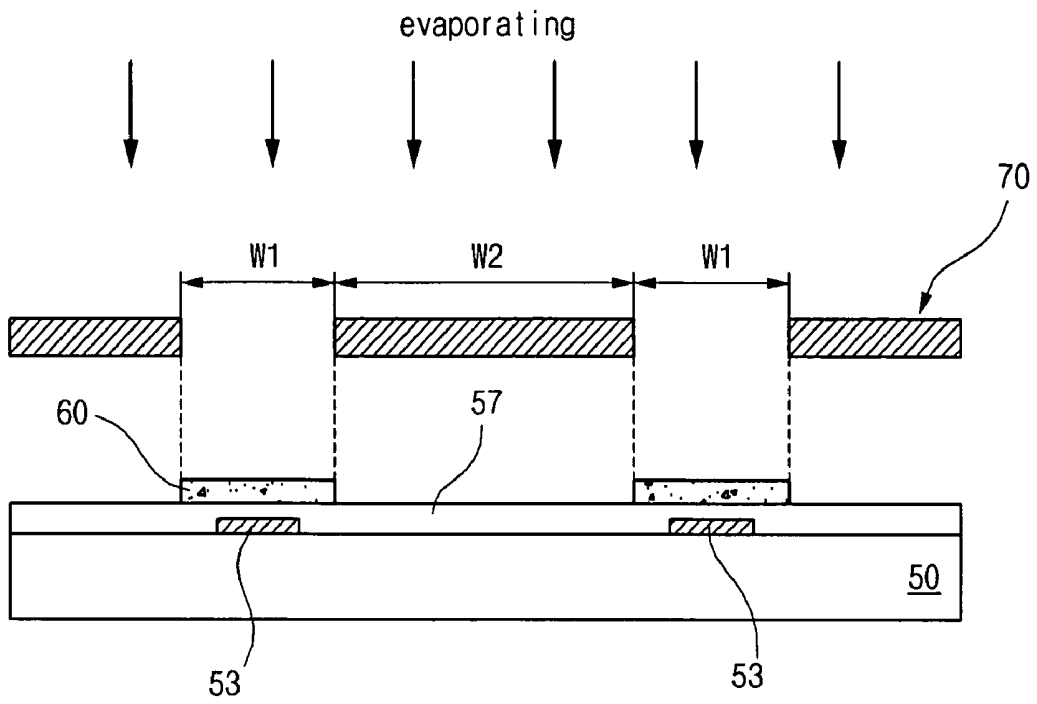

FIG. 3A

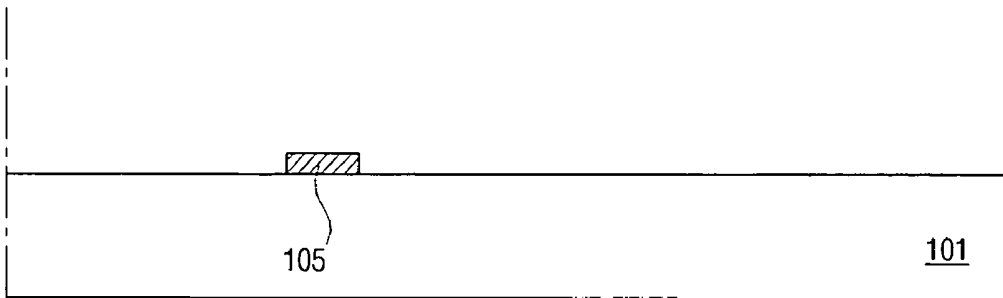

FIG. 3B

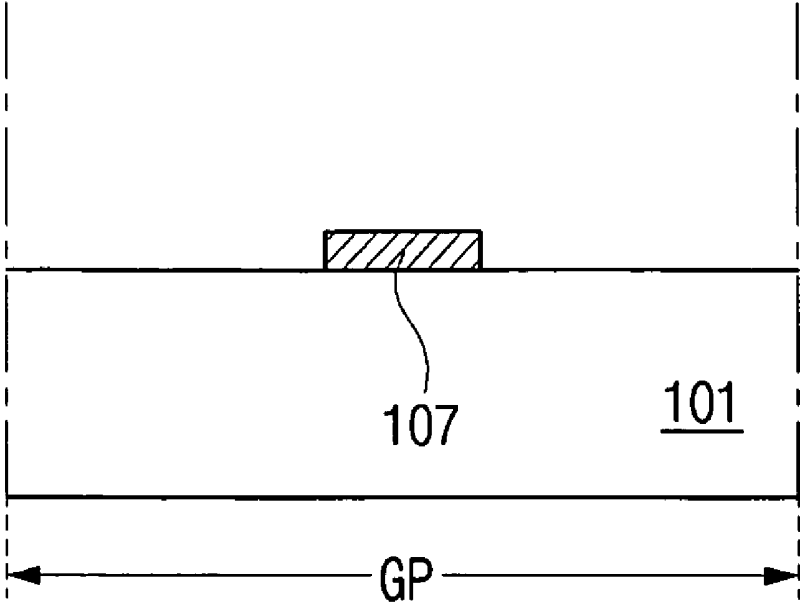

FIG. 3C

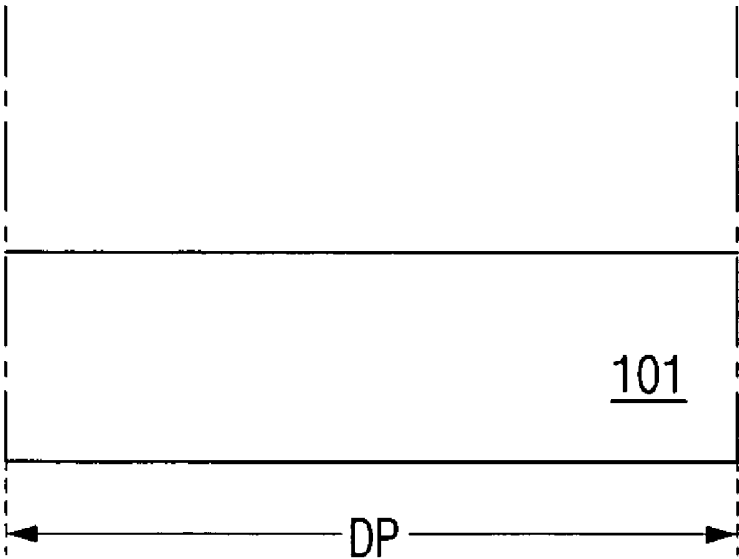

FIG. 4A

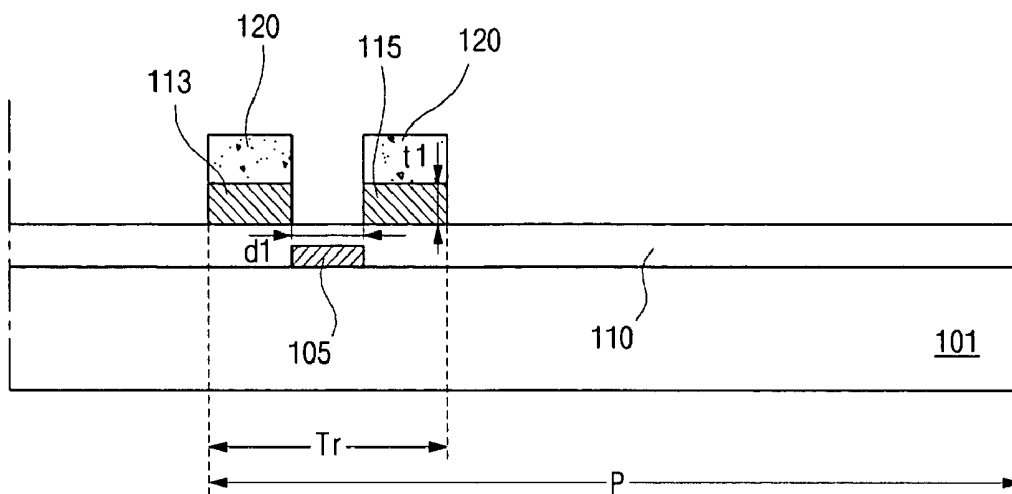

FIG. 4B

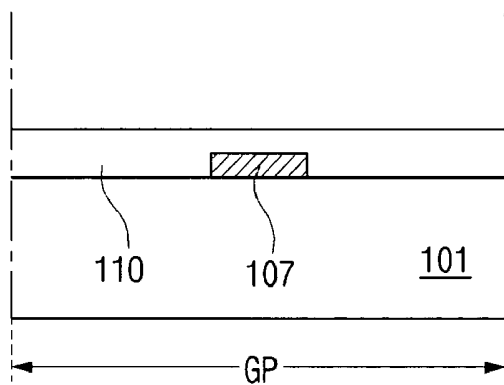

FIG. 4C

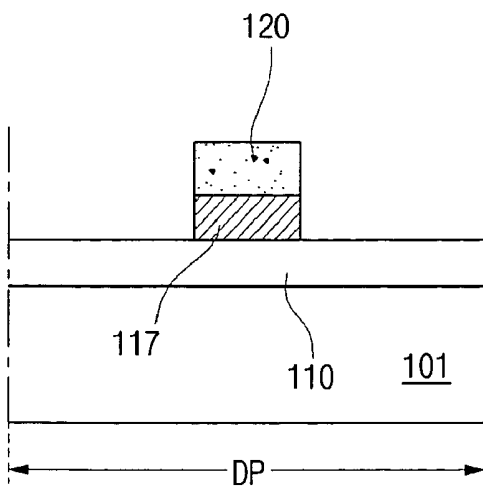

FIG. 5A

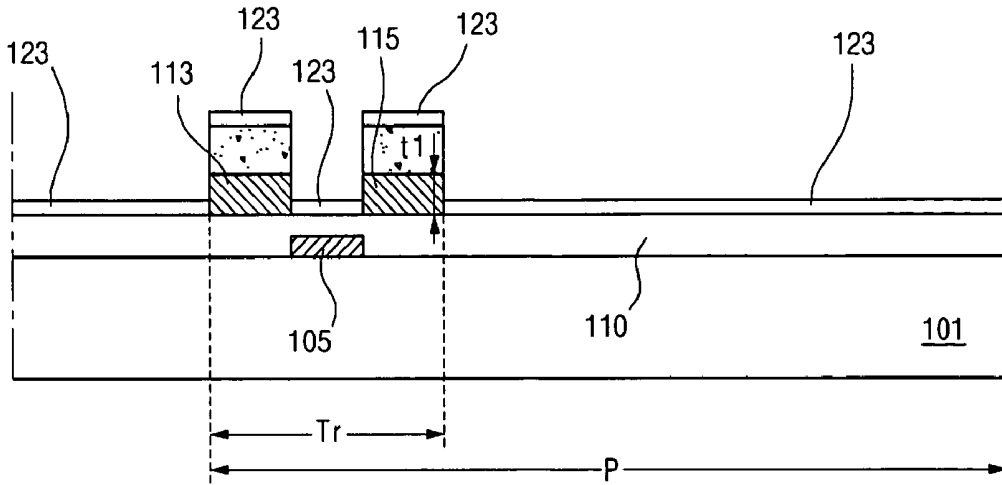

FIG. 5B

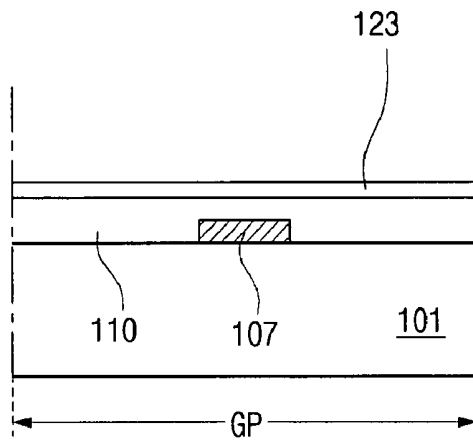

FIG. 5C

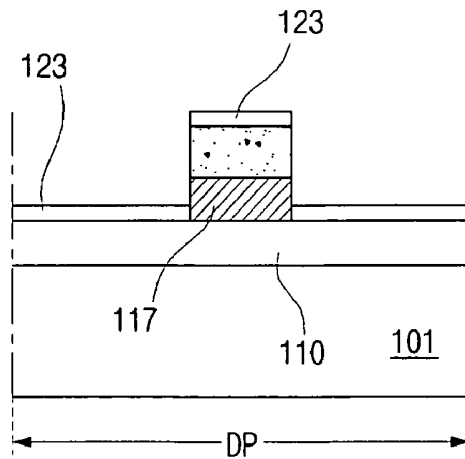

Fig. 6A

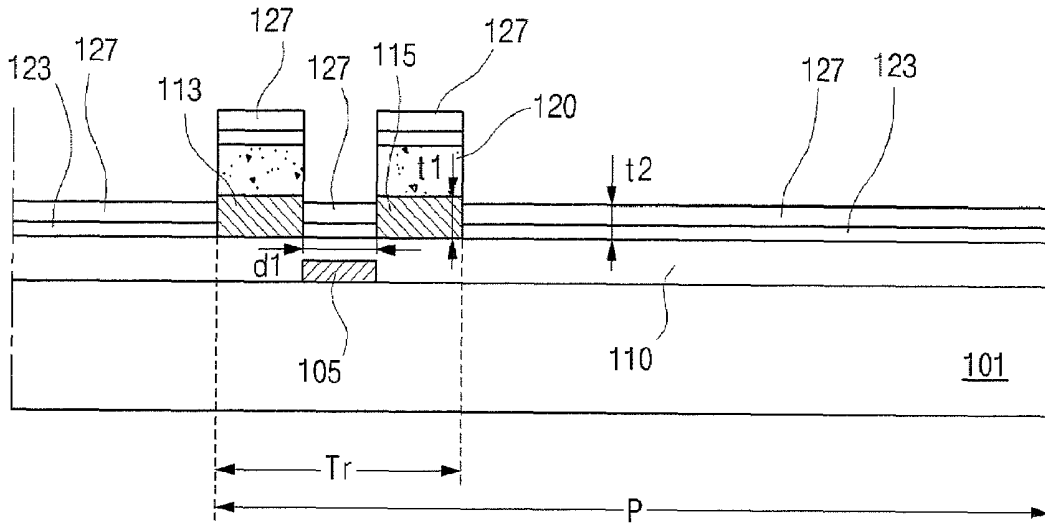

Fig. 6C

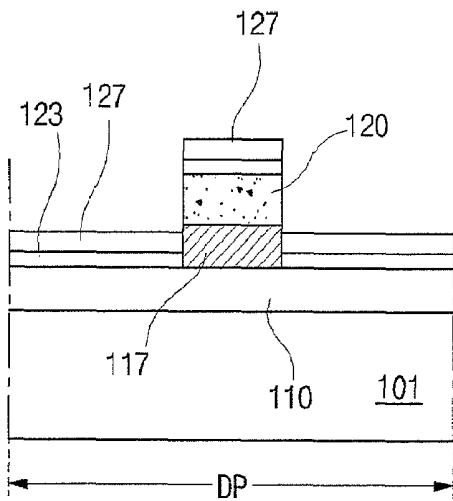

FIG. 6B

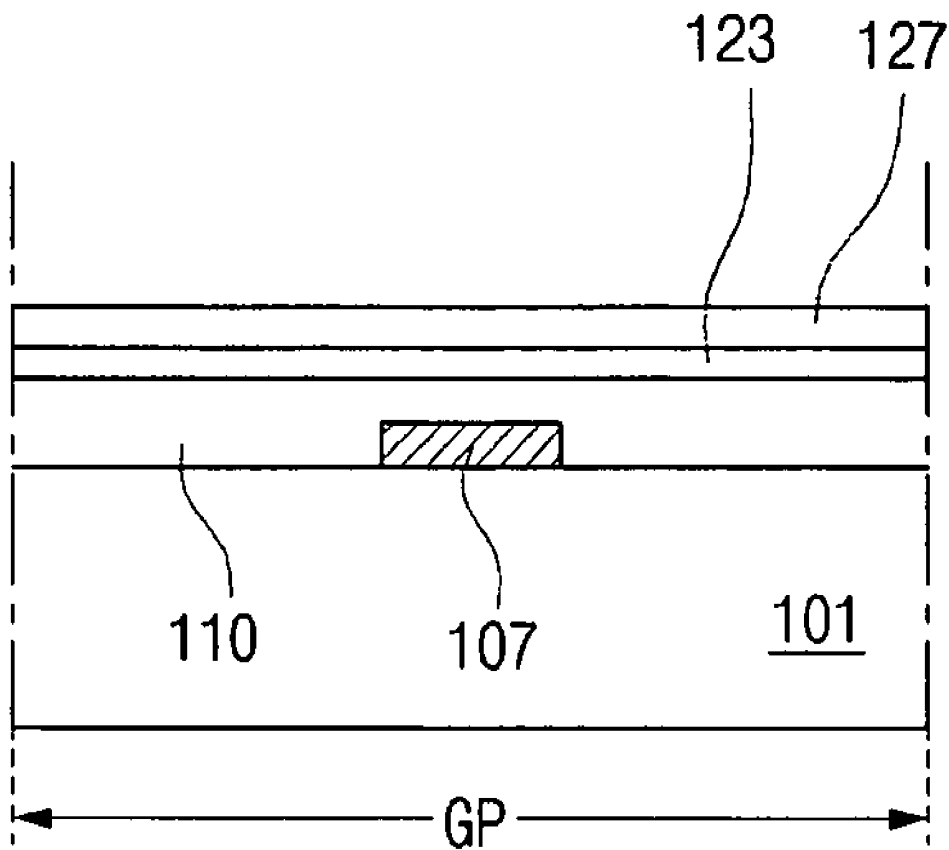

Fig. 7A

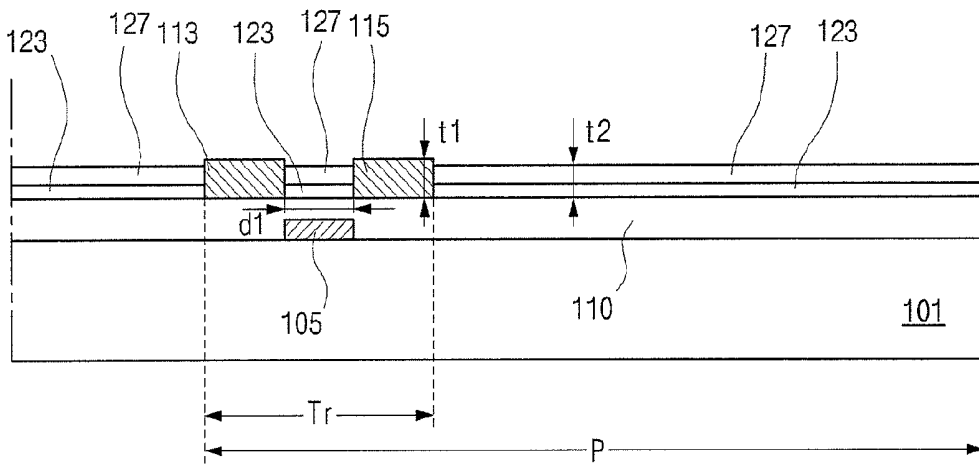

Fig. 7C

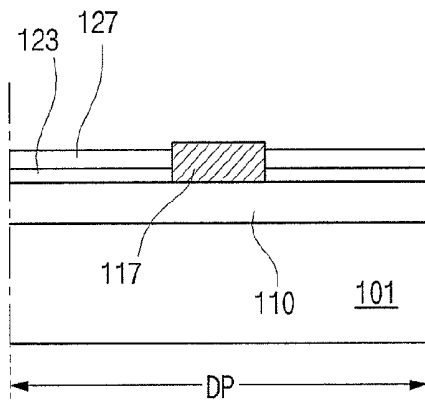

FIG. 7B

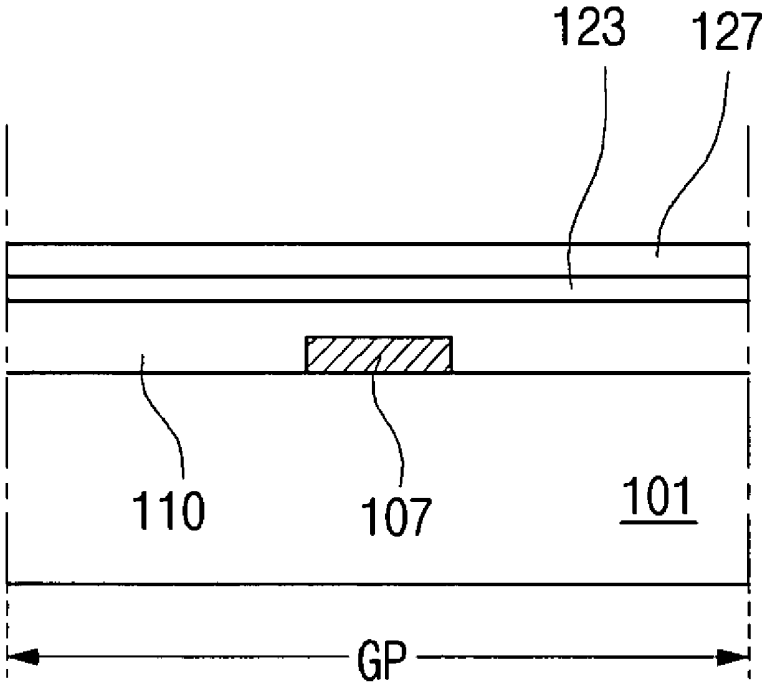

FIG. 8A

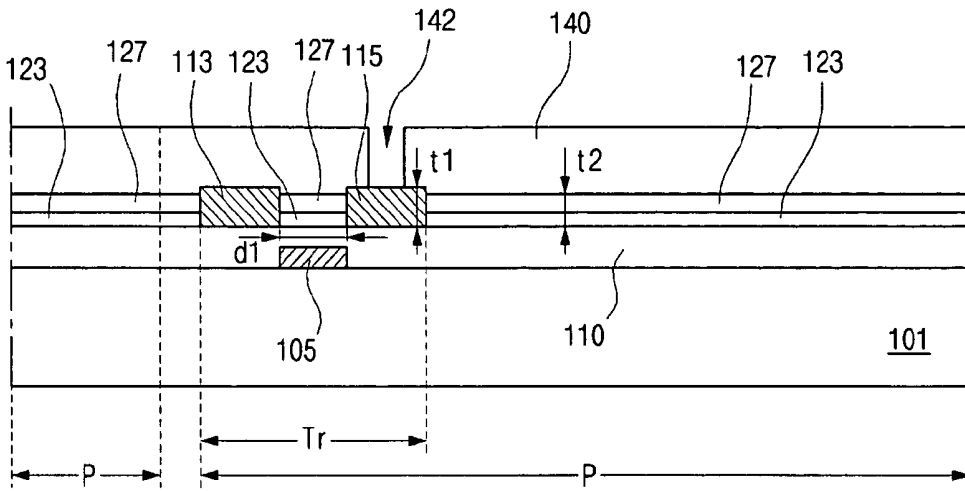

FIG. 8B

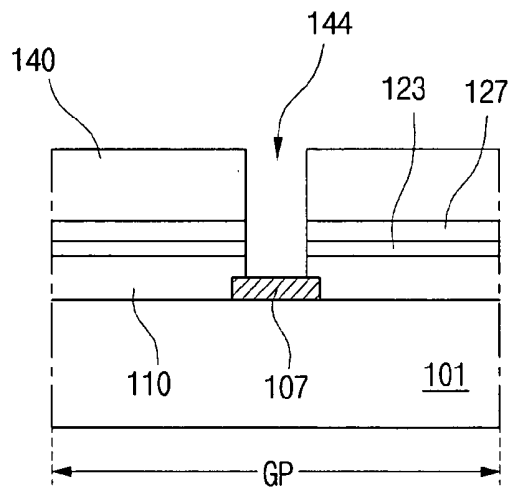

FIG. 8C

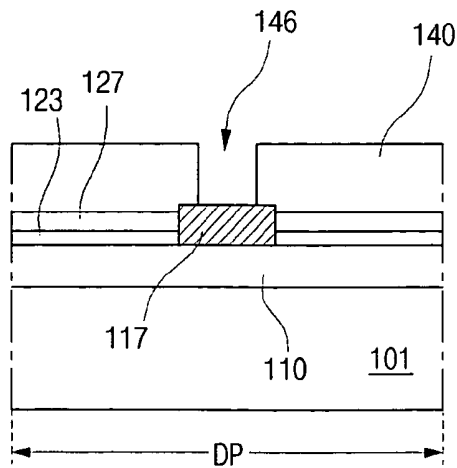

FIG. 9A

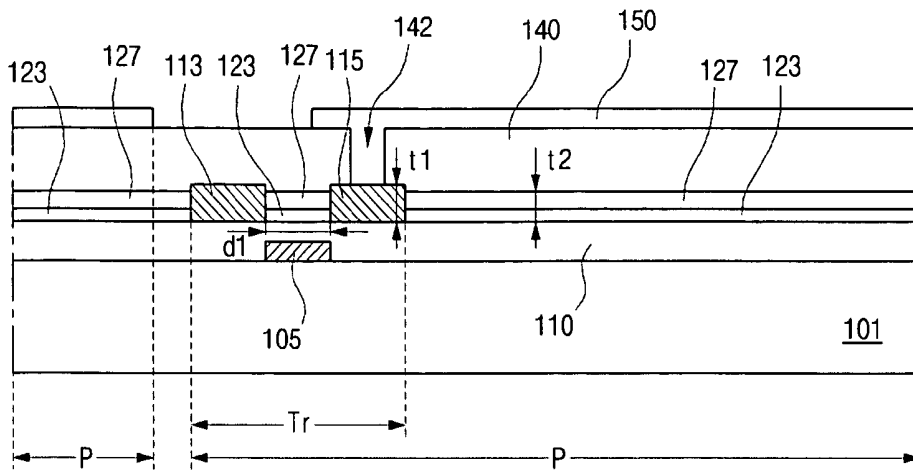

FIG. 9B

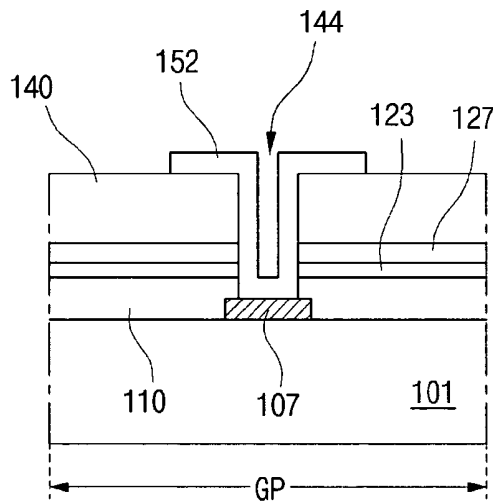

FIG. 9C

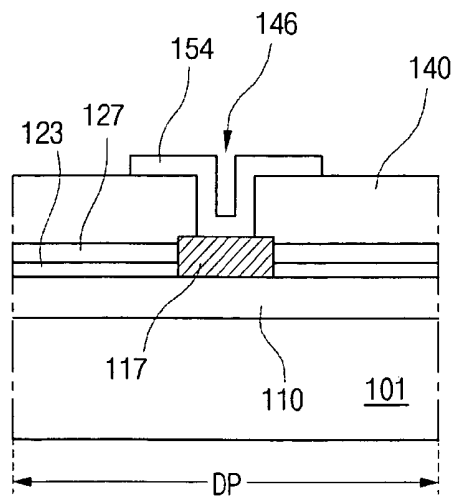

FIG. 10A

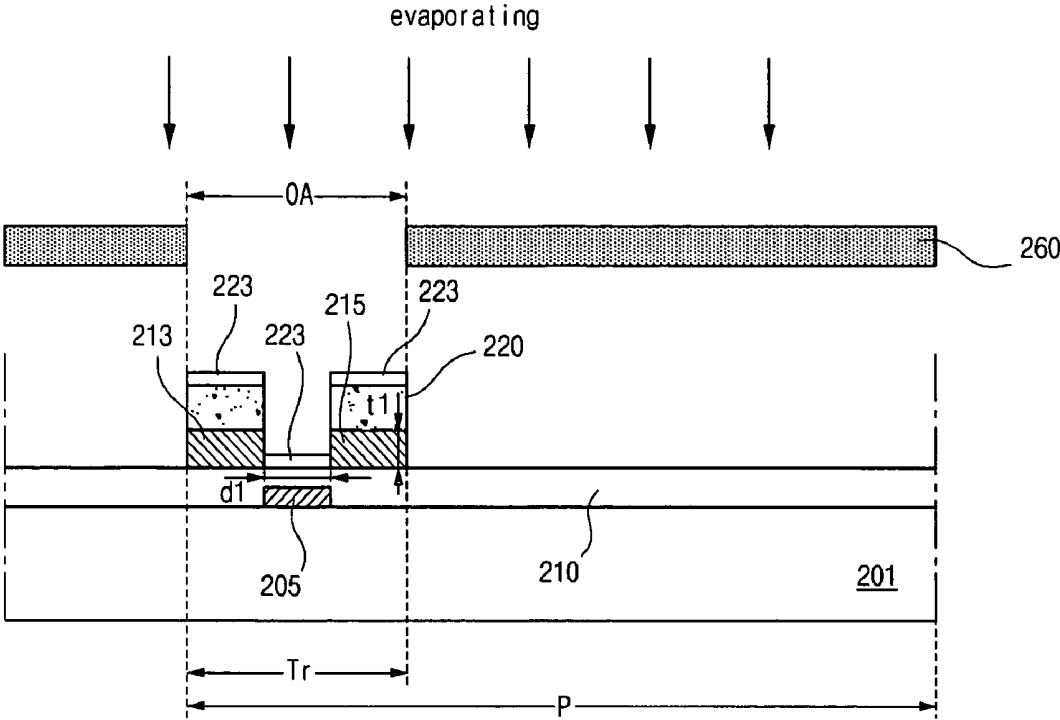

FIG. 10B

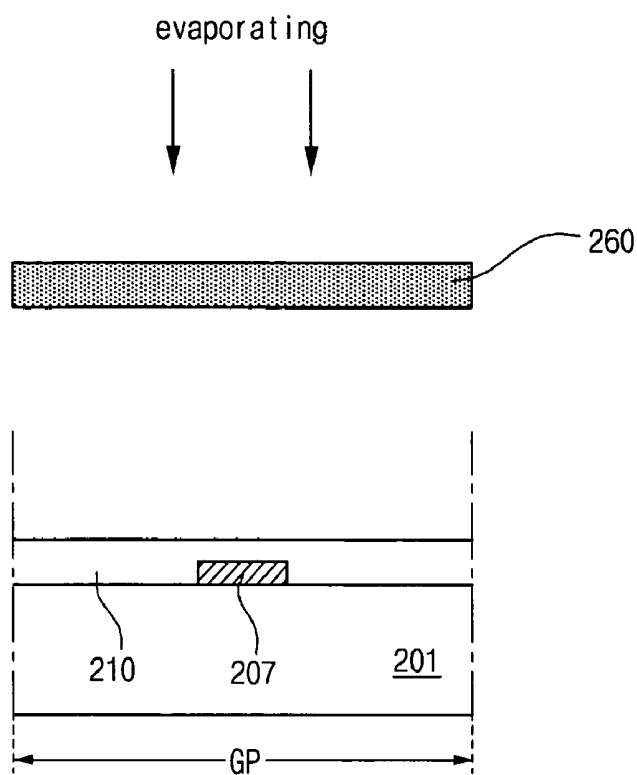

FIG. 10C

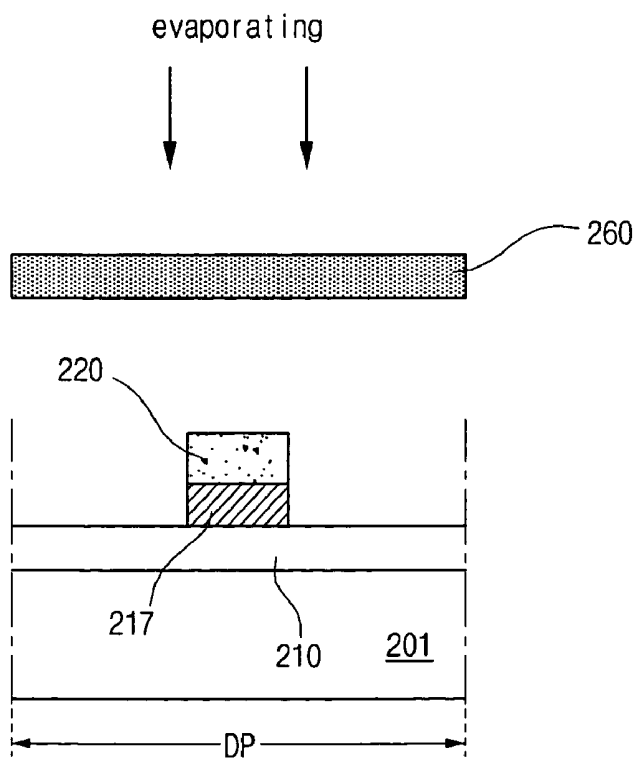

FIG. 11A

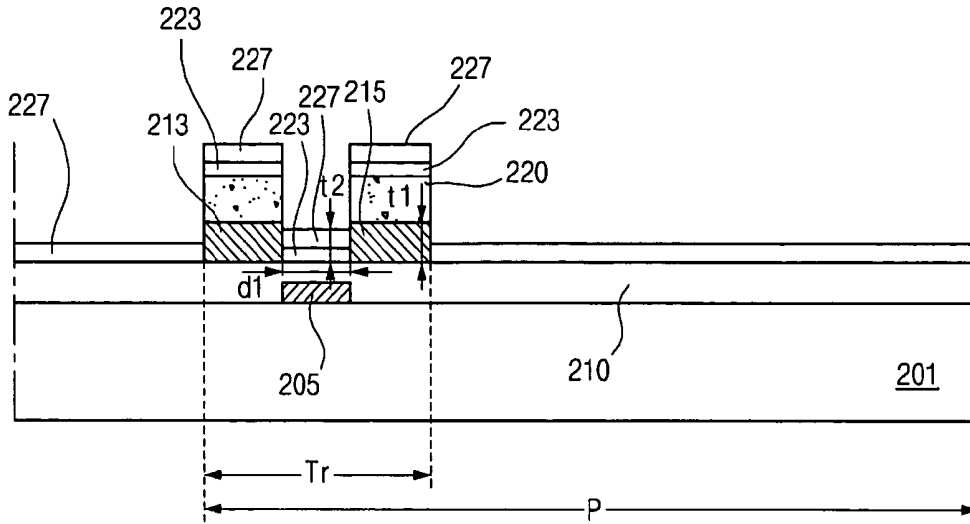

FIG. 11B

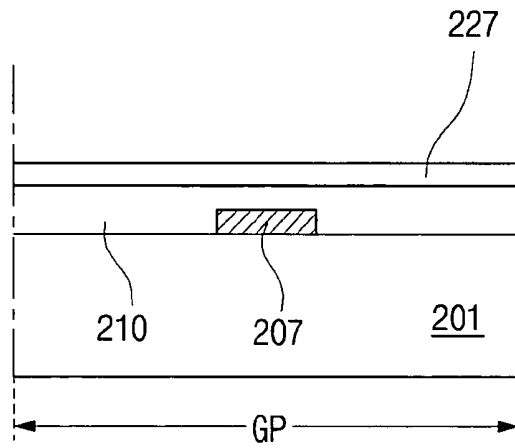

FIG. 11C

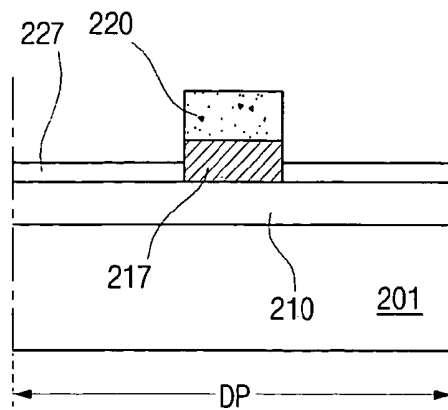

FIG. 12A

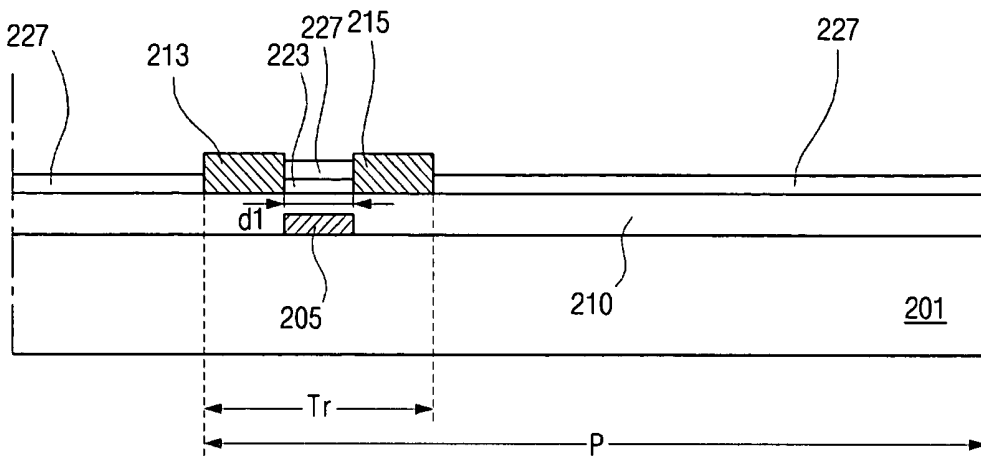

FIG. 12B

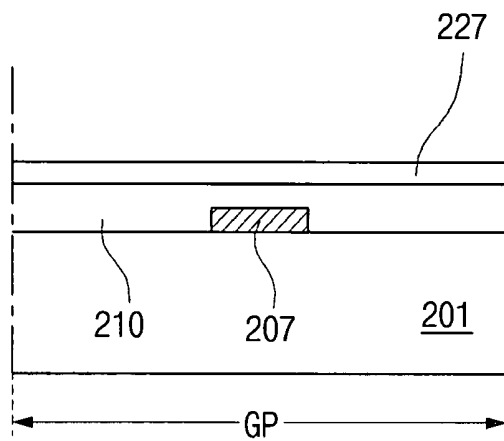

FIG. 12C

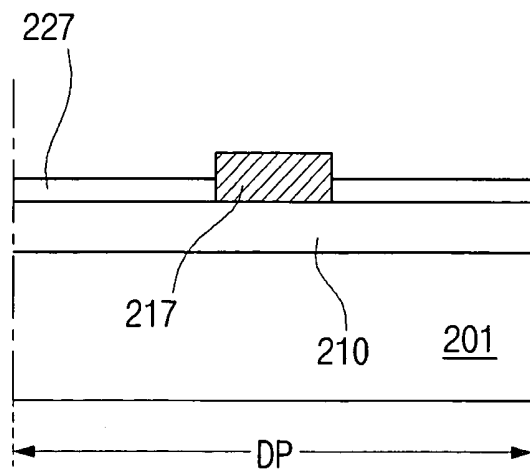

FIG. 13A

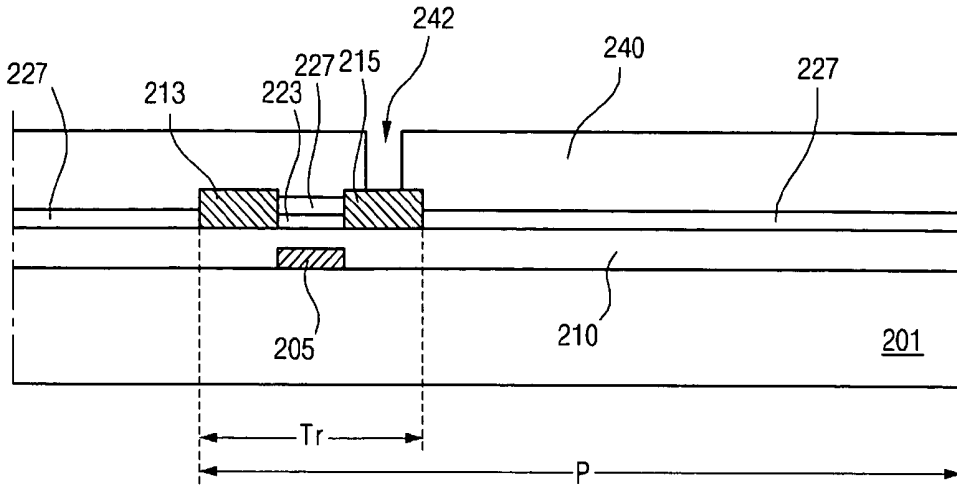

FIG. 13B

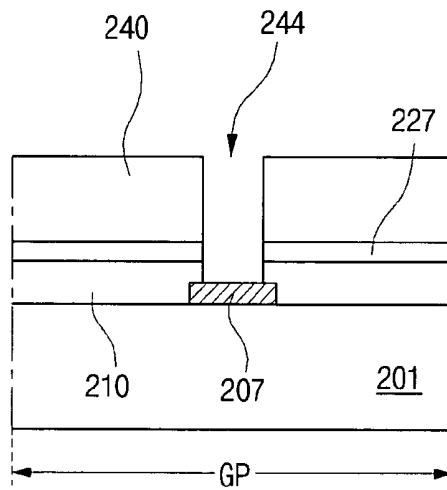

FIG. 13C

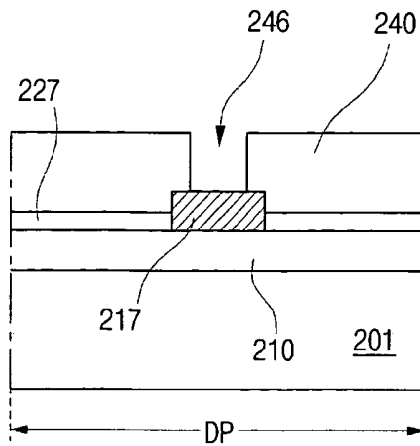

FIG. 14A

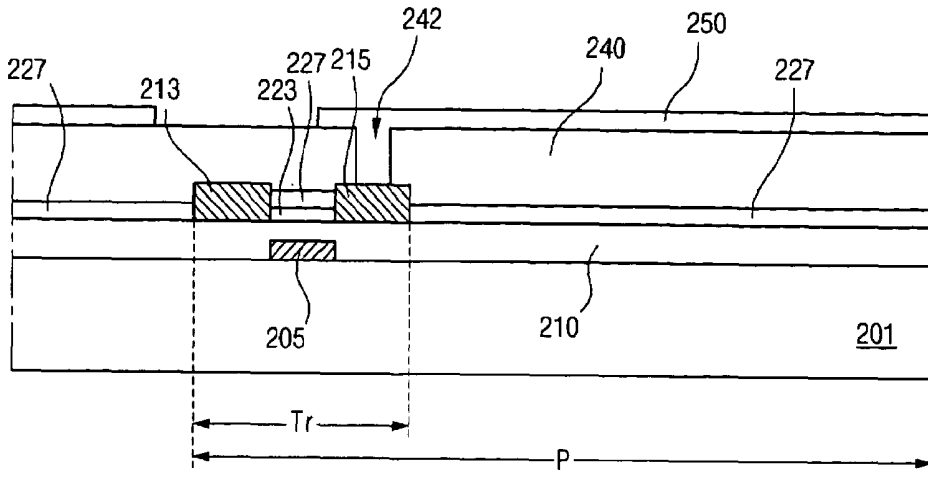

FIG. 14B

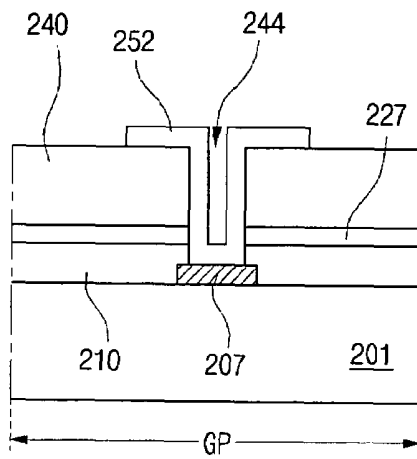
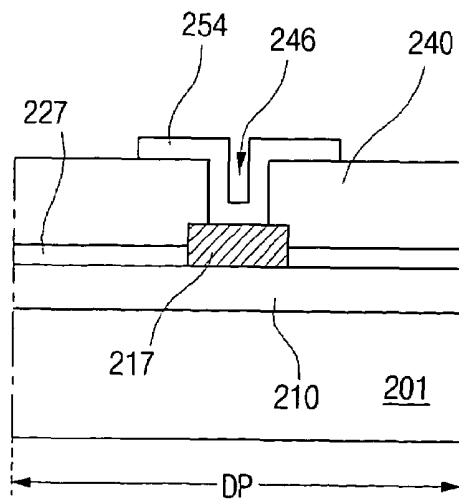

FIG. 14C



**FABRICATION METHOD OF A LIQUID
CRYSTAL DISPLAY DEVICE USING SMALL
MOLECULE ORGANIC SEMICONDUCTOR
MATERIAL**

This Nonprovisional application claims priority under 35 U.S.C. §119(a) on Patent Application No. 2004-0075984 filed in Korea on Sep. 22, 2004, the entire contents of which are hereby incorporated by reference.

BACKGROUND OF THE INVENTION

1. Field of the Invention

The present invention relates to a liquid crystal display (LCD) device, and more particularly, to an array substrate of an LCD device and a method of fabricating the same.

2. Discussion of the Background Art

In general, a liquid crystal display (LCD) device utilizes optical anisotropy and birefringence properties of liquid crystal molecules to display images. The LCD device usually has first and second substrates spaced apart from and opposing each other, and a liquid crystal layer interposed therebetween. The first and second substrates respectively have electrodes for forming an electric field between the electrodes. That is, if a voltage is applied to the electrodes of the LCD device, an electric field is formed between the electrodes and the electric field changes the alignment of the liquid crystal molecules. The changed alignment of the liquid crystal molecules controls a light transmittance through the liquid crystal layer and thus images can be displayed by controlling the light transmittance through the liquid crystal layer.

Among the various type of LCD devices commonly used, active matrix LCD (AM-LCD) devices have been developed because of their high resolution and superiority in displaying moving images. The AM-LCD device includes a thin film transistor (TFT) in each pixel region as a switching device, a pixel electrode in each pixel region, and a common electrode.

FIG. 1 is an exploded perspective view of an LCD device according to the related art. As shown in FIG. 1, an LCD device 20 has an upper substrate 22 having a black matrix 25, a color filter layer 26 and a common electrode 28 on the color filter layer 26. The LCD device further includes a lower substrate 12 having a thin film transistor (TFT) T and a pixel electrode 18 connected to the TFT T. The color filter layer 26 includes red, green and blue color filters 26a, 26b and 26c.

A liquid crystal layer 30 is interposed between the upper and lower substrates 22 and 12. The lower substrate 12 is referred to as an array substrate because array lines including a gate line 14 and a data line 16 are formed thereon. The gate line 14 and the data line 16 cross each other, and the TFT T as a switching element is disposed in a matrix and is connected to the gate line 14 and the data line 16. The gate line 14 and the data line 16 cross each other to define a pixel region P. The TFT T is formed near the crossing portion of the gate line 14 and the data line 16. The pixel electrode 18 is formed of a transparent conductive material in the pixel region P. The upper substrate 22 is referred to as a color filter substrate because the color filter layer 26 is formed thereon.

The upper and lower substrates 22 and 12 are attached with a seal pattern (not shown) through a liquid crystal cell process. The seal pattern keeps a cell gap of the LCD device 20 uniform and prevents liquid crystal materials in the space between the upper and lower substrates 22 and 12 from leakage. Although not shown, the upper and lower alignment layers are formed at boundaries between the liquid crystal layer 30 and the upper and lower substrates 22 and 12, respectively, wherein the upper and lower alignment layers can

improve reliability for alignment of the liquid crystal layer 30. In addition, the LCD device 20 includes at least one polarizer (not shown) on or under an outside surface thereof, and a backlight unit (not shown) may be disposed under the LCD device 20 as a light source.

An image signal transmitted by the data line 16 is applied to a predetermined pixel electrode 18 by sequentially scanning ON/OFF signals of the TFT T to the gate line 14. Hence, the liquid crystal layer 30 is driven by a vertical electric field, and images are displayed based on the change of the light transmittance thereof.

The base substrate of the LCD device generally has been made of a transparent glass substrate. Recently, a plastic substrate, which is lighter and more flexible than the glass substrate, is suggested as a base substrate of the LCD device for a small portable display device such as a notebook and personal digital assistants (PDA).

However, since the plastic substrate is more susceptible to heat and chemical treatment than the glass substrate, it is difficult for the LCD device to adopt the plastic substrate as the base substrate because a process of manufacturing an array substrate is usually performed under a high temperature more than about 200 degrees Celsius. Further, it usually requires several high temperature processes when manufacturing the array substrate. Therefore, to solve the problem, a color filter substrate without the array elements may be made of the plastic substrate, but the array substrate is still usually made of the glass substrate.

Another solution is using small molecule organic material and applying a low temperature process less than about 200 degrees Celsius so that the flexible plastic substrate can be used for manufacturing the array substrate.

Hereinafter, a method of fabricating the array substrate of the LCD device using the flexible plastic substrate under a low temperature of less than about 200 degrees Celsius will be described. It should be noted that although a metal layer, an insulating layer and a passivation layer do not affect the characteristics of the thin film transistor in the low temperature process, when a semiconductor layer including a channel region of the thin film transistor is made of a general semiconductor material under the low temperature process, an electric property of the thin film transistor will be affected because the semiconductor layer has a weak inner structure under the low temperature process and conductivity of the semiconductor layer is reduced in comparison with the semiconductor layer under the general temperature process.

To solve the problem, the semiconductor layer is made of an organic semiconductor material, wherein the organic semiconductor material includes a small molecule material and a polymer material. Here, the small molecule organic semiconductor material has higher conductivity than the polymer organic semiconductor material.

FIG. 2 is a schematic cross-sectional view of an array substrate including a semiconductor layer of a small molecule organic semiconductor material for an LCD device using a flexible plastic substrate according to the related art. In FIG. 2, a gate line (not shown) and a gate electrode 53 are formed by depositing and patterning a metallic material on a plastic substrate 50. A gate insulating layer 57 is then formed by coating an organic insulating material over an entire surface of the substrate 50 including the gate line and the gate electrode 53.

A semiconductor layer 60 is formed by evaporating the small molecule organic semiconductor material such as Pentacene ($C_{22}H_{14}$) over the gate electrode 53. Since the small molecule organic semiconductor material such as Pentacene is in a powder form and is difficult to be made in a solution

form, it is difficult to deposit Pentacene by a chemical vapor deposition (CVD) process and pattern Pentacene by the photolithography process in which Pentacene would contact a photoresist material having moisture, a development solution and a stripping solution. Accordingly, the semiconductor layer **60** is evaporated by using a shadow mask **70** having an opening portion (not shown). However, this process imposes a limitation with respect to a width **W1** of the semiconductor layer **60** and a distance **W2** between the semiconductor layers **60**.

More specifically, the shadow mask **70** is made of a metallic material, wherein a width of the opening portion corresponding to the width **W1** of the semiconductor layer **60** should be at least more than about 40 micrometers. That is, the width of the opening portion should be at least more than about 40 micrometers, and the distance between the opening portions corresponding to the distance **W2** between the semiconductor layers **60** should be more than about 120 micrometers. This is because diffusion of the material should be taken into account in the evaporation process.

As a result, the width **W1** of the semiconductor layer **60** is at least more than 40 micrometers, wherein a length of a channel for the regular semiconductor layer **60** is less than about 10 micrometers. Reducing a size of the semiconductor layer **60** except the channel region helps to increase the aperture ratio. The more the pixel region is increased, the more the resolution is increased, and the less the size of the pixel region is reduced. Accordingly, the less the size of the thin film transistor in the pixel region is reduced, the less the size of the channel is also reduced. Accordingly, the small molecule organic semiconductor layer **60** using the shadow mask **70** is not suitable for a high-resolution array substrate because the width **W1** of the semiconductor layer **60** is at least more than about 40 micrometers.

Further, when the source and drain electrodes are formed later by the photolithography process using a development solution and a stripping solution, those solutions will damage the semiconductor layer **60** under the source and drain electrodes. Therefore, it is difficult to apply the small molecule organic semiconductor layer in an array substrate of the high resolution LCD.

SUMMARY OF THE INVENTION

The present invention is directed to an array substrate and a method of fabricating the same, which substantially obviate one or more of problems due to limitations and disadvantages of the background art.

An object of the present invention is to provide an array substrate of an LCD device which has a channel region within a few micrometers and can be manufactured by evaporating a small molecule organic semiconductor material susceptible to moisture.

Another object of the present invention is to provide a method of fabricating an array substrate of an LCD device which has a channel region within a few micrometers and can be manufactured by evaporating a small molecule organic semiconductor material susceptible to moisture.

To achieve these and other advantages and in accordance with the purpose of the present invention, as embodied and described, a liquid crystal display structure includes: a pixel region; and a thin film transistor on a substrate, the thin film transistor being located adjacent to the pixel region, the thin film transistor including: a gate electrode; a gate insulating layer having a top surface; a source electrode and a drain electrode at the top surface of the gate insulating layer; a semiconductor layer disposed at the top surface of the gate

insulating layer, the semiconductor layer between the source electrode and the drain electrode defining a channel region, the semiconductor layer including a small molecule organic semiconductor material; and a first passivation layer covering the channel region, a top surface of the first passivation layer coinciding with or being below a top surface of each of the source electrode and the drain electrode.

In another aspect, a method of fabricating a liquid crystal display structure includes the steps of: forming a gate electrode on a substrate; forming a gate insulating layer; forming a source electrode, a drain electrode, and a channel region between the source electrode and the drain electrode above the gate insulating layer; forming a semiconductor layer by evaporating a small molecule organic semiconductor material in the channel region; and forming a first passivation layer covering the semiconductor layer so that a top surface of the first passivation layer coincides with or is below a top surface of each of the source electrode and the drain electrode.

Further scope of applicability of the present application will become more apparent from the detailed description given hereinafter. However, it should be understood that the detailed description and specific examples, while indicating preferred embodiments of the invention, are given by way of illustration only, since various changes and modifications within the spirit and scope of the invention will become apparent to those skilled in the art from this detailed description.

BRIEF DESCRIPTION OF THE DRAWINGS

The present invention will become more fully understood from the detailed description given hereinbelow and the accompanying drawings which are given by way of illustration only, and thus are not limitative of the present invention.

FIG. 1 is an exploded perspective view of an LCD device according to the related art.

FIG. 2 is a schematic cross-sectional view of an array substrate including a semiconductor layer of a small molecule organic semiconductor material for an LCD device using a flexible plastic substrate according to the related art.

FIGS. 3A-3C, 4A-4C, 5A-5C, 6A-6C, 7A-7C, 8A-8C and 9A-9C are schematic cross-sectional views showing a process of manufacturing an array substrate of an LCD device according to a first embodiment of the present invention.

FIGS. 10A-10C, 11A-11C, 12A-12C, 13A-13C, and 14A-14C are schematic cross-sectional views showing a process of manufacturing an array substrate of an LCD device according to a second embodiment of the present invention.

DETAILED DESCRIPTION OF THE ILLUSTRATED EMBODIMENT

Reference will now be made in detail to the illustrated embodiment of the present invention, which is illustrated in the accompanying drawings. Wherever possible, similar reference numbers will be used throughout the drawings to refer to the same or like parts.

FIGS. 3A-3C, 4A-4C, 5A-5C, 6A-6C, 7A-7C, 8A-8C and 9A-9C are schematic cross-sectional views showing a process of manufacturing an array substrate of an LCD device according to a first embodiment of the present invention. Here, FIGS. 3A, 4A, 5A, 6A, 7A, 8A and 9A show a pixel region P including a thin film transistor region Tr; FIGS. 3B, 4B, 5B, 6B, 7B, 8B and 9B show a gate pad region GP; and FIGS. 3C, 4C, 5C, 6C, 7C, 8C and 9C show a data pad region DP.

Although not shown, when a base substrate for the process is a plastic substrate, the plastic substrate may be severely bent due to the flexibility through a loading step. Accordingly, a rigid substrate such as glass may be attached to the base substrate.

In FIGS. 3A-3C, a first metal layer (not shown) is deposited on a substrate **101** as a base substrate by sputtering under a low temperature such as about less than 200 degrees Celsius. Next, a photoresist material is coated on the first metal layer and a mask (not shown) having an opening portion is disposed over the photoresist material. A photoresist pattern (not shown) is formed by exposing and developing the photoresist material using the mask. At this time, a portion of the first metal layer is exposed through the photoresist pattern. Then, a gate line (not shown), a gate electrode **105** and a gate pad electrode **107** are formed by etching the exposed first metal layer. Although not shown, the gate line is connected to the gate electrode **105** and the gate pad electrode **107** is connected to an end portion of the gate line. Next, the photoresist pattern overlapping the gate line, the gate electrode **105** and the gate pad electrode **107** is removed from the substrate **101** by ashing or stripping.

In FIGS. 4A-4C, a gate insulating layer **110** is formed over the substrate **101** including the gate line, the gate electrode **105** and the gate pad electrode **107** by coating an organic material such as a polyvinylpyrrolidone (PVP) and benzocyclobutene (BCB). In this embodiment, the gate insulating layer **110** made of the organic insulating material has a level top surface without a step between a portion including the gate patterns such as the gate line, the gate electrode **105** and the gate pad electrode **107** and another portion not including the gate patterns. However, it is not required that the gate insulating layer **110** has a level top surface, which will be further described hereinbelow.

Next, a second metal layer is formed on the gate insulating layer **110** by depositing a metallic material under a low temperature such as about less than 200 degrees Celsius. Although the second metal layer of the related art has a thickness within a range 1,500 Angstroms to 2,000 Angstroms, a thickness t_1 of the second metal layer of the first embodiment of the present invention is at least more than 3,000 Angstroms concerning a lift-off process that will be performed later.

A photoresist material is coated on an entire surface of the second metal layer and a mask having an opening portion is disposed over the photoresist material. A photoresist pattern **120** is formed by exposing and developing the photoresist material, wherein the photoresist pattern **120** is formed in a region for a data line (not shown), a source electrode **113**, a drain electrode **115** and a data pad electrode **117**. The second metal layer can be made of the same metallic material as the first metal layer.

Although not shown, the data line crossing the gate line to define the pixel region P, the source electrode **113**, and the drain electrode **115** spaced apart from the source electrode **113**, and the data pad electrode **117** are formed by etching the exposed metal layer corresponding to the open portion of the photoresist pattern **120**, wherein the source electrode **113** is connected to the data line and the data pad electrode **117** is connected to an end portion of the data line.

In this embodiment, the photoresist pattern **120** overlapping the data line, the source electrode **113**, the drain electrode **115** and the data pad electrode **117** remains after forming the data line, the source electrode **113**, the drain electrode **115** and the data pad electrode **117** without employing the steps of ashing or stripping. Here, an interval region between the source electrode **113** and the drain electrode **117** corre-

sponds to a channel region, which may have a distance d_1 of about 10 micrometers for a high resolution LCD device. Alternatively, the distance d_1 may be less than 40 micrometers of a minimum limitation for a general resolution model.

In FIGS. 5A-5C, a semiconductor layer **123** is formed by evaporating a small molecule organic semiconductor material on an entire surface of the substrate **101** having the data line, the source electrode **113**, the drain electrode **115**, and the photoresist pattern **120** overlapping the data line, the source electrode **113**, the drain electrode **115**. For example, the transmittance of the small molecule organic semiconductor material is more than about 85% and this small molecule organic semiconductor material includes Pentacene.

For example, a thickness of the semiconductor layer **123** is about 500 Angstroms. It is noted that the data line, the source electrode **113**, the drain electrode **115** and the data pad electrode **117** include a top surface and a side portion, wherein the side portion is exposed through the semiconductor layer **123** due to a characteristic of the step of evaporating. Generally, the semiconductor layer **123** formed by evaporating has a weak deposition property at the side surface having a step and thus is rarely deposited in the side surface of the source and drain electrodes **113** and **115**.

As explained above, the thickness t_1 of each of the source and drain electrodes **113** and **115** is at least about 3,000 Angstroms including another thickness of the photoresist pattern **120**, and hence the semiconductor layer **123** is easily cut at the side surface of the source and drain electrodes **113** and **115**. In addition, since the semiconductor layer **123** in the pixel region P will not be removed, the semiconductor layer **123** should have high light transmittance. For example, the semiconductor layer **123** of this embodiment is made of the small molecule organic semiconductor material of about 85% transmittance.

In FIGS. 6A-6C, a first passivation layer **127** is formed by depositing an inorganic material such as a silicon oxide (SiO_x) on the semiconductor layer **123**. Here, the first passivation layer **127** is not deposited at the side surface of the source and drain electrodes **113** and **115**. In this embodiment, the thickness t_1 of each of the data line, the source electrode **113**, the drain electrode **115** and the data pad electrode **117** is equal to or greater than a total thickness t_2 of the combination of the semiconductor layer **123** and the first passivation layer **127**. In addition, a portion of the first passivation layer **127** on the photoresist pattern **120** is higher than another portion of the first passivation layer **127** in the pixel region P.

Next, in FIGS. 7A-7C, the photoresist pattern **120** is removed by dipping using a stripping solution. Specifically, since the side surface of the source and drain electrodes **113** and **115** are exposed through the semiconductor layer **123** and the first passivation layer **127**, in the step of the dipping, the stripping solution easily contacts and reacts with the exposed portion of the photoresist pattern **120** near to the side surface of the source and drain electrodes **113** and **115**. At this time, portions of the semiconductor layer **123** and the first passivation layer **127** overlapping the photoresist pattern **120** are simultaneously removed with the photoresist pattern **120**. The process can be referred to as a lift-off process. In this embodiment, a top surface of the photoresist pattern **120** does not contact the stripping solution, but a side surface of the photoresist pattern **120** contacts the stripping solution due to the open portions of the semiconductor layer **123** and the first passivation layer **127** at the side surface of the source and drain electrodes **113** and **115**, thereby separating the photoresist pattern **120** from the substrate **101**.

As mentioned, in the first embodiment, the gate insulating layer **110** made of the organic insulating material has a level

top surface without a step, and the thickness t_1 of each of the data line, the source electrode **113**, the drain electrode **115** and the data pad electrode **117** is equal to or greater than a total thickness t_2 of the combination of the semiconductor layer **123** and the first passivation layer **127**. However, the gate insulating layer **110** may have a top surface with a step structure. When the gate insulating layer **110** has a top surface with a step structure, the top surface of the first passivation layer **127** may coincide with or be below the top surface of each of the source electrode **113** and the drain electrode **115** to facilitate the lift-off process. In other words, by controlling the top surface of the first passivation layer **127** to coincide with or be below the top surface of each of the source electrode **113** and the drain electrode **115**, the sidewalls of the photoresist pattern **120** will not be covered by the first passivation layer **127**. Accordingly, the photoresist pattern **120** can be effectively removed, thereby removing the semiconductor layer **123** and the first passivation layer **127** overlapping the photoresist pattern **120** during the lift-off process. Accordingly, it is not necessary that the gate insulating layer **110** is a level top panel and the thickness t_1 of the source and drain electrodes **113** and **115** is equal or greater to the thickness t_2 of the combination of the first passivation layer **127** and the semiconductor layer **123**. If the top surface of the first passivation layer **127** coincides with or is below the top surface of each of the source electrode **113** and the drain electrode **115**, the photoresist pattern **120** can be effectively removed because the entire sidewalls of the photoresist pattern **120** are exposed when performing the lift-off process.

Although the semiconductor layer **123** is made of a material that is susceptible to the stripping solution, the semiconductor layer **123** is protected from the stripping solution because the first passivation layer **127** covers the semiconductor layer **123**. Since the semiconductor layer **123** is formed between the source electrode **113** and the drain electrode **115**, a width d_1 of the semiconductor layer **123** can be controlled as a desired value, for example, less than about 40 micrometers.

In FIGS. **8A-8C**, a second passivation layer **140** is formed by coating an organic material such as polyvinylpyrrolidone (PVP) and benzocyclobutene (BCB) on the first passivation layer **127**, the data line, the source electrode **113**, and the drain electrode **115**. In this embodiment, the second passivation layer **140** has a level surface because it is made of an organic material. Next, first, second and third contact holes **142**, **144** and **146** that respectively expose portions of the drain electrode **115**, the gate pad electrode **107** and the data pad electrode **117** in the second passivation layer **140** are formed by patterning the second passivation layer **140**.

In FIGS. **9A-9C**, a pixel electrode **150** is formed by depositing and patterning a transparent material such as indium tin oxide (ITO) or indium zinc oxide (IZO), wherein the pixel electrode **150** is connected to the drain electrode **115** via the first contact hole **142**. A gate auxiliary pad electrode **152** is connected to the gate pad electrode **107** via the second contact hole **144**, and a data auxiliary pad electrode **154** is connected to the data pad electrode **117** via the third contact hole **146**.

Accordingly, the semiconductor layer **123** of the small molecule organic semiconductor material can be controlled to a few micrometers. However, in the first embodiment, the semiconductor layer **123** of the first embodiment is formed in the pixel region P as well as the thin film transistor region Tr. Therefore, the semiconductor layer **123** should be made of the material of about 85% transmittance. Therefore, there is a limitation in the material choice of the semiconductor layer **123** in the first embodiment. Further, the semiconductor layer

123 may affect the luminance of the pixel region P although the semiconductor layer **123** is selected from a material having good transmittance.

To increase the choice of the materials for the semiconductor layer, the semiconductor layer **123** is formed so as not to occupy the pixel region P in a second embodiment of the present invention. For convenience sake, since steps before forming the semiconductor layer **123** according to the first embodiment of the present invention can be applied to the second embodiment, the corresponding description of the second embodiment will not be repeated here.

FIGS. **10A-10C**, **11A-11C**, **12A-12C**, **13A-13C** and **14A-14C** are schematic cross-sectional views showing a process of manufacturing an array substrate of an LCD device according to the second embodiment of the present invention. Here, FIGS. **10A**, **11A**, **12A** and **13A** show a pixel region P including a thin film transistor region Tr; FIGS. **10B**, **11B**, **12B** and **13B** show a gate pad region GP; and FIGS. **100C**, **11C**, **12C** and **13C** show a data pad region DP.

In FIGS. **10A-10C**, a data line (not shown), a source electrode **213**, a drain electrode **215** and a data pad electrode **217** are formed on a gate insulating layer **210** and a photoresist pattern **220** for patterning the data line, the source electrode **213**, the drain electrode **215** and the data pad electrode **217** remains. A shadow mask **260** having an open portion OA is disposed over the photoresist pattern **220**, wherein the open portion OA corresponds to the source electrode **213**, the drain electrodes **215** and an interval between the source and drain electrodes **213** and **215**, i.e., the channel region. A semiconductor layer **223** is formed by evaporating the material of the semiconductor layer through the shadow mask **260** onto a substrate **201** including the photoresist pattern **220**, wherein the semiconductor layer **223** may be made of a small molecule organic semiconductor material without concerning the transmittance in comparison with the semiconductor layer **123** (of FIG. **5a**) of the first embodiment. This is because the semiconductor layer **223** is not formed in the pixel region P and the transmittance of the semiconductor layer **223** is no longer an issue.

In FIGS. **11A-11C**, a first passivation layer **227** is formed by depositing an inorganic material such as a silicon oxide (SiOx) over an entire surface of the substrate **201** including the semiconductor layer **223**. The first passivation layer **227** also directly contacts the gate insulating layer **210** in the pixel region. Here, the first passivation layer **227** is not formed at the side surfaces of the data line, the source electrode **213**, the drain electrode **215** and the data pad electrode **217** with a substantially high step. In this embodiment, the thickness t_1 of each of the data line, the source electrode **213**, the drain electrode **215** and the data pad electrode **217** is equal to or greater than a total thickness t_2 of the combination of the semiconductor layer **223** and the first passivation layer **227**.

In FIGS. **12A-12C**, the photoresist pattern **220** is removed from the substrate **201** by dipping using a stripping solution. This process may be referred to as a lift-off process. In addition, the semiconductor layer **223** and the first passivation layer **227** on the photoresist pattern **220** are simultaneously removed and the semiconductor layer **223** is patterned between the source and drain electrodes **213** and **215** covered by the first passivation layer **227**. Accordingly, since the semiconductor layer **223** has a width corresponding to a distance d_1 between the source and drain electrodes **213** and **215**, the width of the semiconductor layer **223** can be easily controlled. It should be noted that although in this embodiment the gate-insulating layer **210** has a level top surface, the scope of the present invention is not limited to this embodiment. In case that the gate insulating layer **210** has a top surface with

a step structure, the top surface of the first passivation layer 227 may coincide with or be below the top surface of each of the source electrode 213 and the drain electrode 215 to facilitate the lift-off process.

In FIGS. 13A-13C, a second passivation layer 240 is formed by coating an organic material such as a polyvinylpyrrolidone (PVP) and benzocyclobutene (BCB) on an entire surface of the substrate 201 including the semiconductor layer 223. Next, first, second and third contact holes 242, 244 and 246 that respectively expose portions of the drain electrode 215, the gate pad electrode 207 and the data pad electrode 217 in the second passivation layer 240 are formed by patterning the second passivation layer 240.

In FIGS. 14A-14C, a pixel electrode 250 is formed by depositing and patterning a transparent material such as indium tin oxide (ITO) or indium zinc oxide (IZO), wherein the pixel electrode 250 is connected to the drain electrode 215 via the first contact hole 242. A gate auxiliary pad electrode 252 is connected to the gate pad electrode 207 via the second contact hole 244, and a data auxiliary pad electrode 254 is connected to the data pad electrode 217 via the third contact hole 246.

Accordingly, the array substrate of the LCD device according to the present invention can provide a fine pattern without a shadow mask or a semiconductor layer using the shadow mask that patterning can be performed later, thereby improving an aperture ratio and luminance.

In addition, although a small molecule organic semiconductor material is susceptible to moisture and chemical treatment, the present invention can provide an array substrate and a method of fabricating the same protecting the small molecule organic semiconductor material from moisture or chemical treatment. Accordingly, a flexible and high resolution LCD device having the semiconductor layer of the small molecule organic semiconductor material can be obtained.

The invention being thus described, it will be obvious that the same may be varied in many ways. Such variations are not to be regarded as a departure from the spirit and scope of the invention, and all such modifications as would be obvious to one skilled in the art are intended to be included within the scope of the following claims.

What is claimed is:

1. A method of fabricating a liquid crystal display structure, comprising the steps of:

- forming a gate electrode on a substrate;
- forming a gate insulating layer;
- forming a metal layer on the gate insulating layer and a photoresist pattern on the metal layer;
- forming a source electrode, a drain electrode, and a channel region between the source electrode and the drain electrode above the gate insulating layer by etching the metal layer corresponding to an open portion of the photoresist pattern;
- forming a semiconductor layer by evaporating a small molecule organic semiconductor material on the gate insulating layer including a pixel region and the photoresist pattern;
- forming a first passivation layer covering the semiconductor layer; and
- removing the semiconductor layer and the first passivation layer overlapping the photoresist pattern with the photoresist pattern.

2. The method of claim 1, wherein the step of forming the gate insulating layer includes forming the gate insulating layer having a level top surface.

3. The method of claim 2, wherein the steps of forming the semiconductor layer and the first passivation layer include forming the semiconductor layer and the first passivation layer so that a sum of a thickness of the semiconductor layer and a thickness of the first passivation layer is equal to or smaller than a thickness of the source electrode and the drain electrode.

4. The method of claim 1, further comprising:

forming a second passivation layer above the first passivation layer; and

directly contacting the second passivation layer to the top surface of each of the source electrode and the drain electrode.

5. The method of claim 1, wherein the step of forming the gate insulating layer includes forming the gate insulating layer in a pixel region.

6. The method of claim 5, wherein the step of forming the semiconductor layer includes:

evaporating the small molecule organic semiconductor material in the pixel region; and

directly contacting the small molecule organic semiconductor material in the pixel region to a top surface of the gate insulating layer in the pixel region.

7. A method of fabricating a liquid crystal display structure, comprising the steps of:

forming a gate electrode on a substrate;

forming a gate insulating layer;

forming a metal layer on the gate insulating layer and a photoresist pattern on the metal layer;

forming a source electrode, a drain electrode, and a channel region between the source electrode and the drain electrode above the gate insulating layer by etching the metal layer corresponding to an open portion of the photoresist pattern;

forming a semiconductor layer by evaporating a small molecule organic semiconductor material in the channel region after applying a shadow mask having an opening corresponding to the channel region, the source electrode and the drain electrode;

forming a first passivation layer covering the semiconductor layer; and

removing the semiconductor layer and the first passivation layer overlapping the photoresist pattern with the photoresist pattern.

8. The method of claim 7, wherein the step of forming the gate insulating layer includes forming the gate insulating layer in a pixel region.

9. The method of claim 8, further comprising:

forming the first passivation layer in the pixel region; and directly contacting the first passivation layer in the pixel region to a top surface of the gate insulating layer in the pixel region.

10. The method of claim 1, wherein the step of forming the gate electrode includes forming the gate electrode on a plastic substrate.

11. The method of claim 10, wherein each of said forming steps is performed under a temperature of less than about 200 degrees Celsius.

12. The method of claim 1, wherein a top surface of the first passivation layer coincide with or is below a top surface of each of the source electrode and the drain electrode.

专利名称(译)	使用小分子有机半导体材料的液晶显示装置的制造方法		
公开(公告)号	US7561219	公开(公告)日	2009-07-14
申请号	US11/168365	申请日	2005-06-29
[标]申请(专利权)人(译)	乐金显示有限公司		
申请(专利权)人(译)	LG.飞利浦液晶CO., LTD.		
当前申请(专利权)人(译)	LG DISPLAY CO., LTD.		
[标]发明人	SEO HYUN SIK PAEK SEUNG HAN CHOI NACK BONG		
发明人	SEO, HYUN-SIK PAEK, SEUNG-HAN CHOI, NACK-BONG		
IPC分类号	G02F1/136 H01L21/00 H01L35/24		
CPC分类号	G02F1/1368 G02F2202/02		
助理审查员(译)	常, CHARLES		
优先权	1020040075984 2004-09-22 KR		
其他公开文献	US20060061702A1		
外部链接	Espacenet USPTO		

摘要(译)

提供一种液晶显示器结构。液晶显示结构包括像素区域和基板上的薄膜晶体管。薄膜晶体管与像素区域相邻并包括栅电极;栅极绝缘层,具有顶表面;栅极绝缘层顶面的源电极和漏电极;半导体层设置在栅极绝缘层的顶表面上,源极电极和漏极之间的半导体层限定沟道区,半导体层包括小分子有机半导体材料;以及覆盖沟道区的第一钝化层,第一钝化层的顶表面与每个源电极和漏电极的顶表面重合或在其下方。

