



US007079121B2

(12) **United States Patent**
Koyama et al.

(10) **Patent No.:** **US 7,079,121 B2**
(45) **Date of Patent:** **Jul. 18, 2006**

(54) **DRIVING CIRCUIT OF LIQUID CRYSTAL DISPLAY DEVICE**

(75) Inventors: **Jun Koyama**, Atsugi (JP); **Yukio Tanaka**, Atsugi (JP); **Yasushi Kubota**, Sakurai (JP); **Tamotsu Sakai**, Tenri (JP)

(73) Assignees: **Semiconductor Energy Laboratory Co., Ltd.**, Kanagawa-ken (JP); **Sharp Kabushiki Kaisha**, Osaka (JP)

(*) Notice: Subject to any disclaimer, the term of this patent is extended or adjusted under 35 U.S.C. 154(b) by 233 days.

(21) Appl. No.: **09/928,988**

(22) Filed: **Aug. 15, 2001**

(65) **Prior Publication Data**

US 2002/0027543 A1 Mar. 7, 2002

Related U.S. Application Data

(62) Division of application No. 09/150,933, filed on Sep. 10, 1998, now Pat. No. 6,281,865.

(30) **Foreign Application Priority Data**

Sep. 11, 1997 (JP) 09-268148

(51) **Int. Cl.**
G09G 3/36 (2006.01)

(52) **U.S. Cl.** **345/204**; 345/1.1; 345/1.2; 345/2.1; 345/2.2; 345/2.3; 345/156; 345/168; 345/169; 345/173; 348/569; 348/734; 725/131; 725/133; 725/141; 725/151

(58) **Field of Classification Search** 345/87, 345/92, 100, 205, 98, 156, 168, 169, 173, 345/1.1, 1.2, 2.1, 2.2, 2.3, 204; 349/43, 46, 349/122, 139, 138; 327/94, 91; 348/734, 348/569; 725/141, 151, 131, 133

See application file for complete search history.

(56) **References Cited**

U.S. PATENT DOCUMENTS

5,148,301 A	9/1992	Sawatsubashi et al.
5,589,847 A	12/1996	Lewis
5,619,222 A	4/1997	So
5,674,758 A	10/1997	McCarthy
5,751,261 A	5/1998	Zavracky et al.
5,815,223 A *	9/1998	Watanabe et al. 349/42
5,933,204 A *	8/1999	Fukumoto 349/43

(Continued)

Primary Examiner—Sumati Lefkowitz

Assistant Examiner—Alexander S. Beck

(74) *Attorney, Agent, or Firm*—Eric J. Robinson; Robinson Intellectual Property Law Office, P.C.

(57) **ABSTRACT**

A driving circuit of a liquid crystal display device including a first insulating substrate on which a plurality of signal lines and a plurality of scan lines are disposed, and pixel transistors made of thin film transistors are disposed in matrix at intersection points of those lines; a second insulating substrate opposite to the first insulating substrate; and a liquid crystal held between the first and second insulating substrates, in which the driving circuit is disposed on the first insulating substrate; each of clock lines or base portions of the clock lines for supplying clock signals to the driving circuit is made of a two-layer structure of the same wiring material as a gate electrode of the thin film transistor and the same wiring material as a source electrode or drain electrode of the thin film transistor; and a wiring line crossing the clock lines or the base portions of the clock lines is made of a wiring line in the same layer as a black matrix covering the pixel transistors.

13 Claims, 19 Drawing Sheets

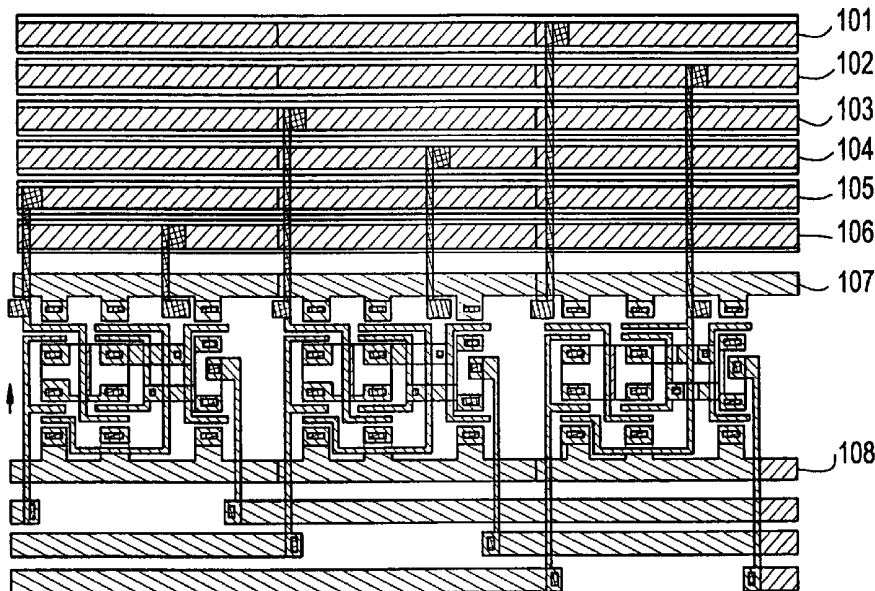

US 7,079,121 B2

Page 2

U.S. PATENT DOCUMENTS

5,994,765 A *	11/1999	Mitra et al.	257/659	6,127,998 A	10/2000	Ichikawa et al.	
6,064,362 A	5/2000	Brownlow et al.		6,175,395 B1 *	1/2001	Yamazaki et al.	349/44
6,108,055 A	8/2000	Oima et al.		6,281,865 B1 *	8/2001	Koyama et al.	345/87

* cited by examiner

FIG. 1

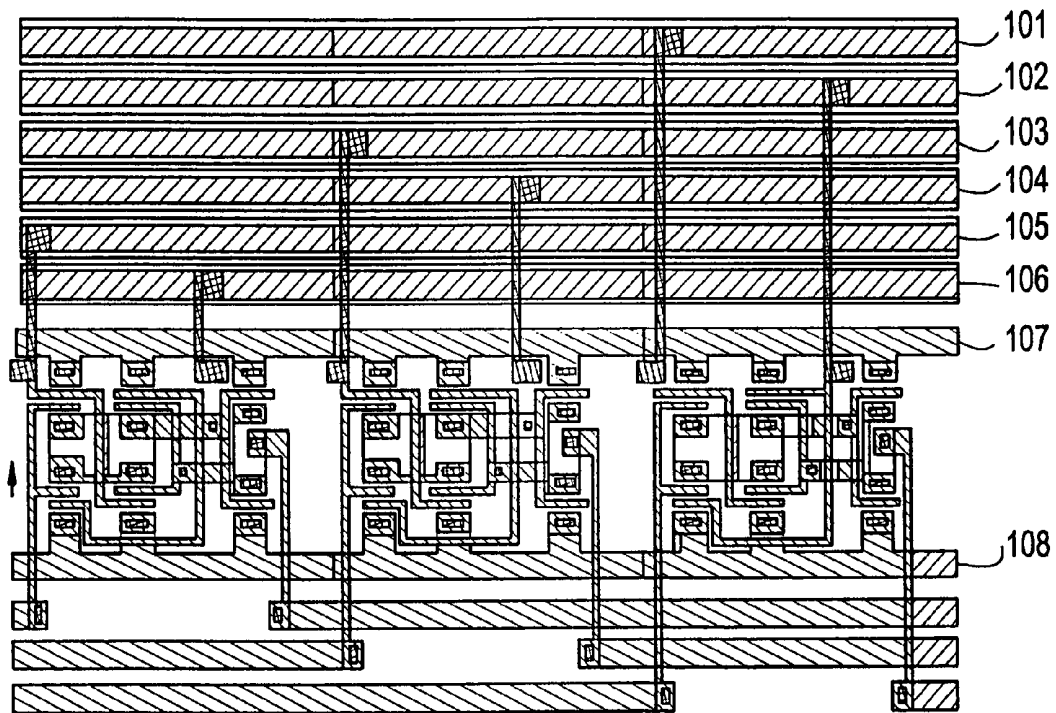

FIG. 2
PRIOR ART

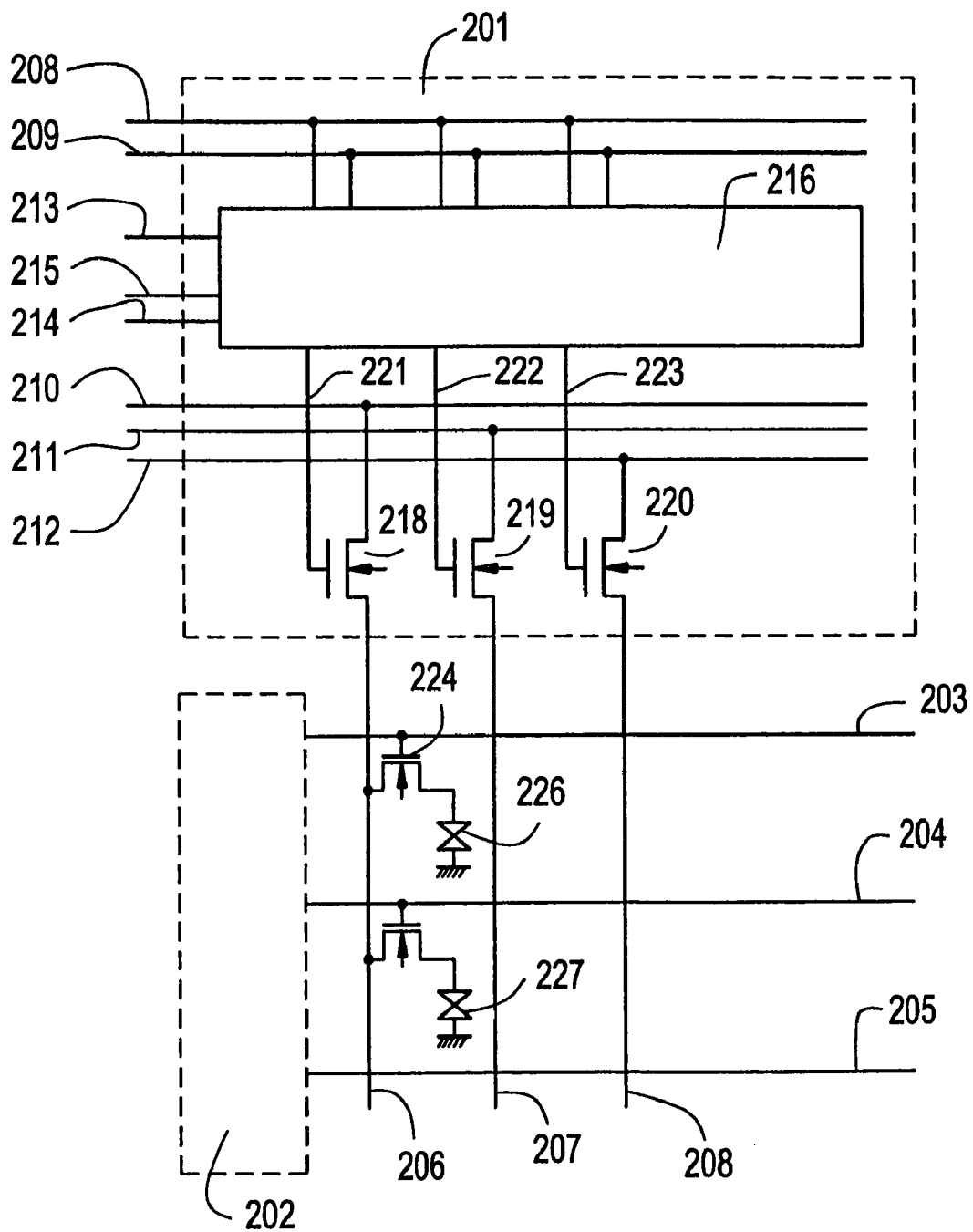

FIG. 3
PRIOR ART

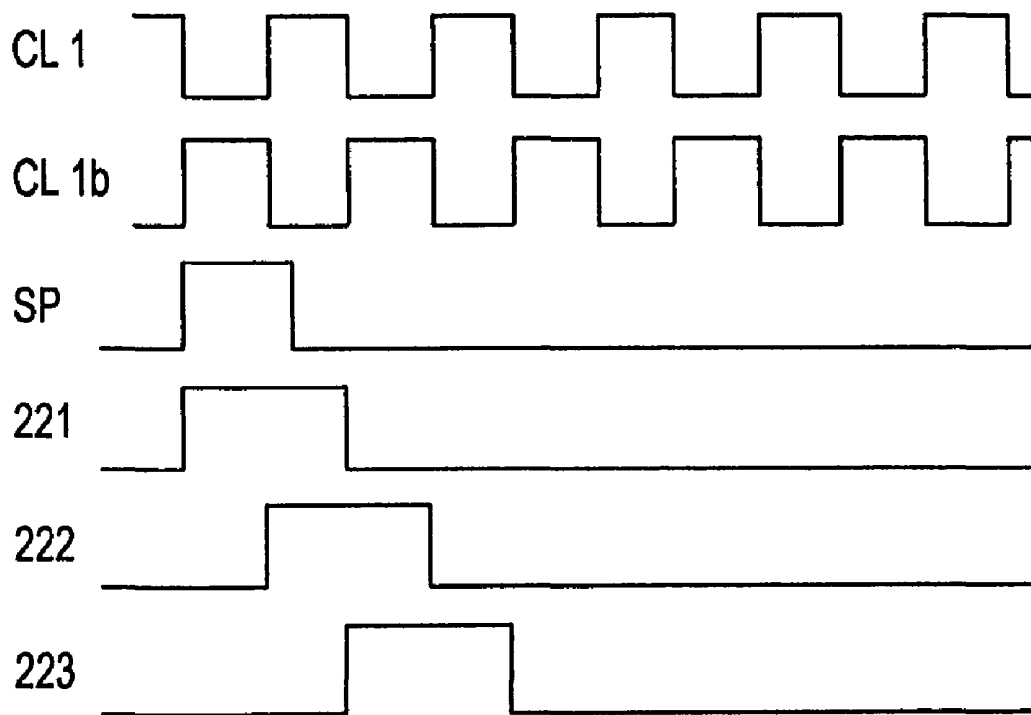

FIG.4A
PRIOR ART

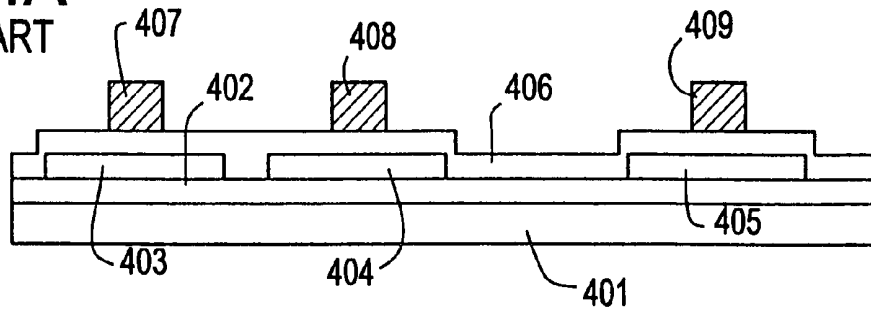

FIG.4B
PRIOR ART

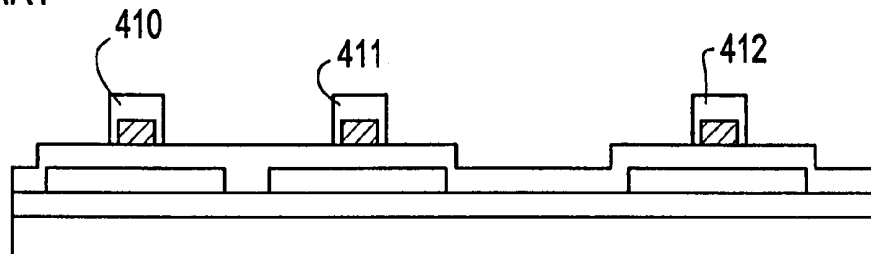

FIG.4C
PRIOR ART

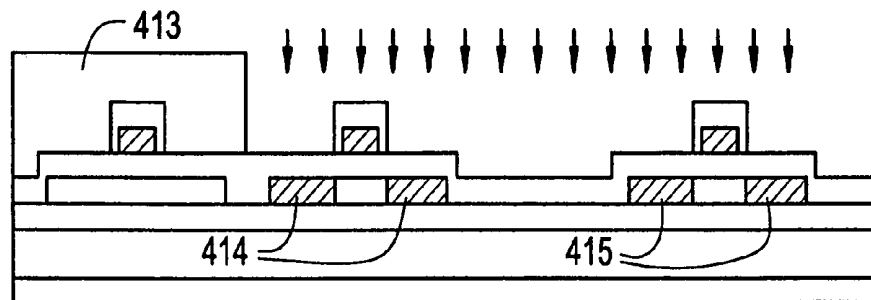

FIG.4D
PRIOR ART

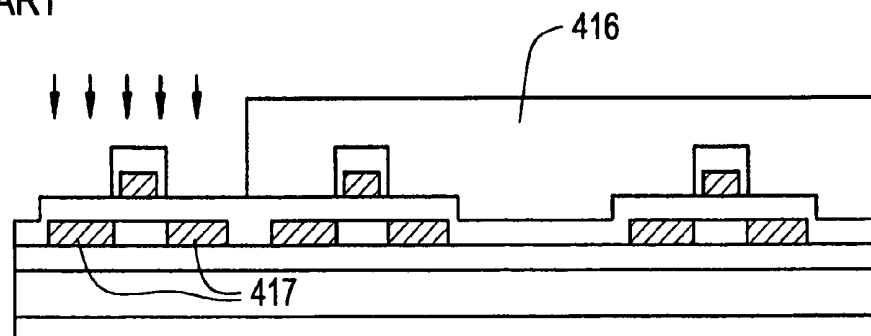

FIG. 5A
PRIOR ART

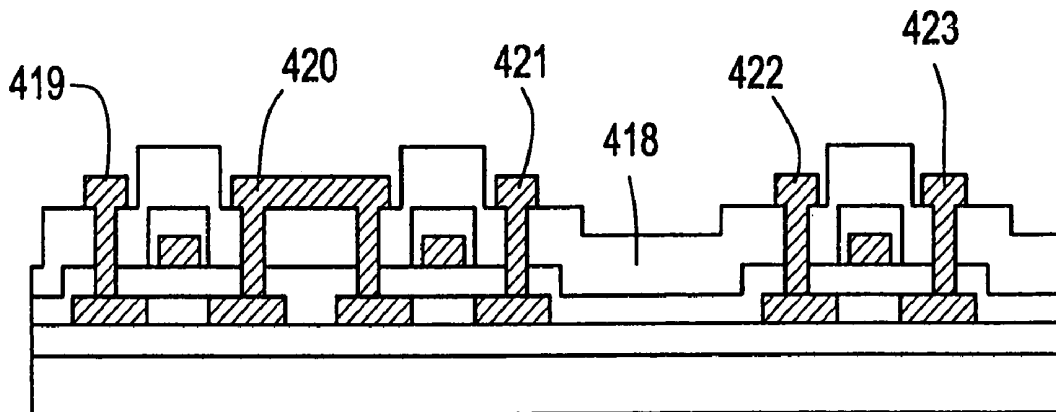
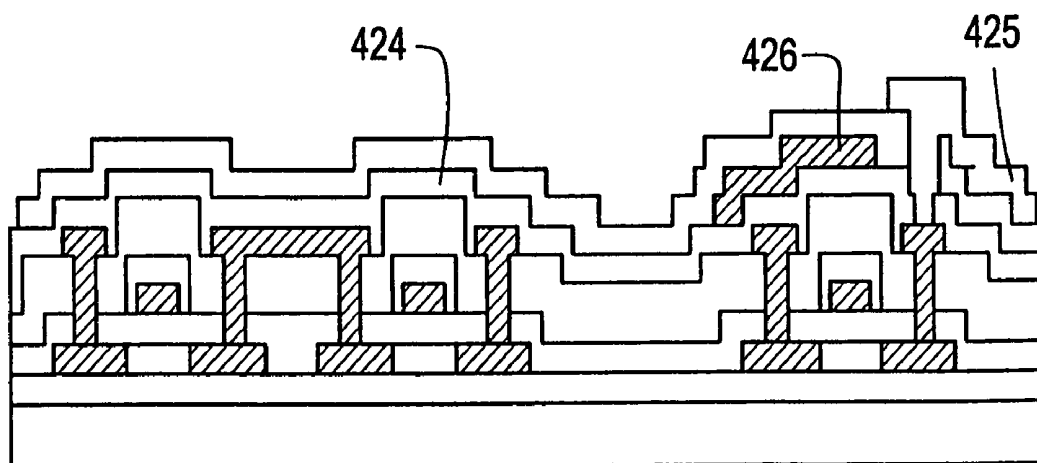

FIG. 5B
PRIOR ART



DRIVER CIRCUIT
TFT



PIXEL TFT

FIG. 6
PRIOR ART

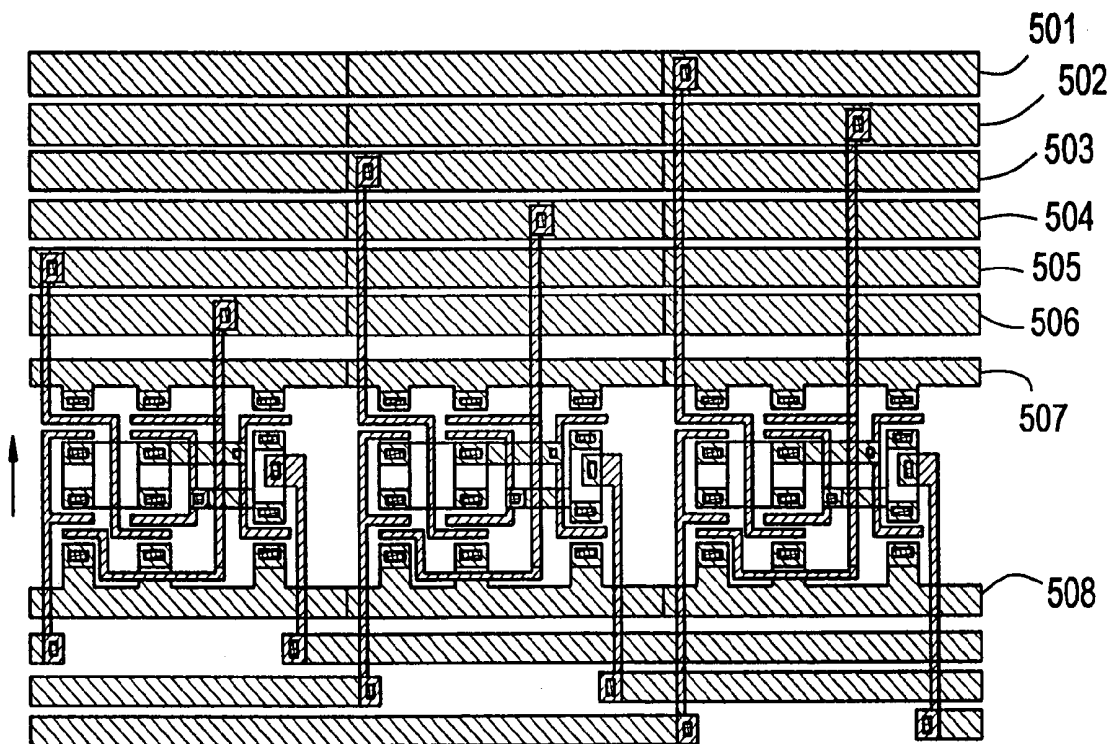
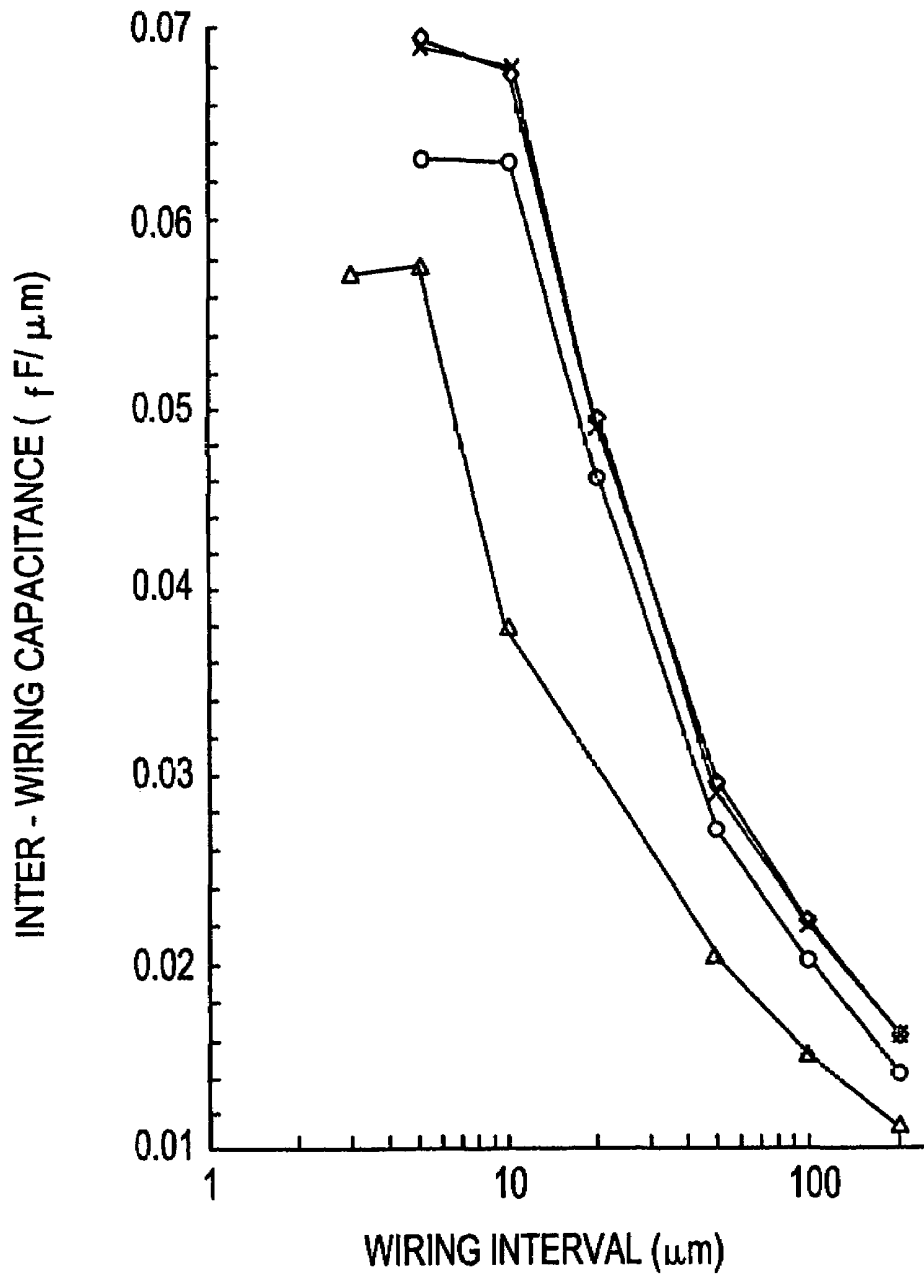

FIG. 7



- △— between Wiring A1 and Gate A1 (width 10μm)
- ◇— between Wiring A1 and Gate A1 (width 30μm)
- between Wiring A1s (width 30μm)
- ×— between Gate A1s (width 30μm)

FIG. 8

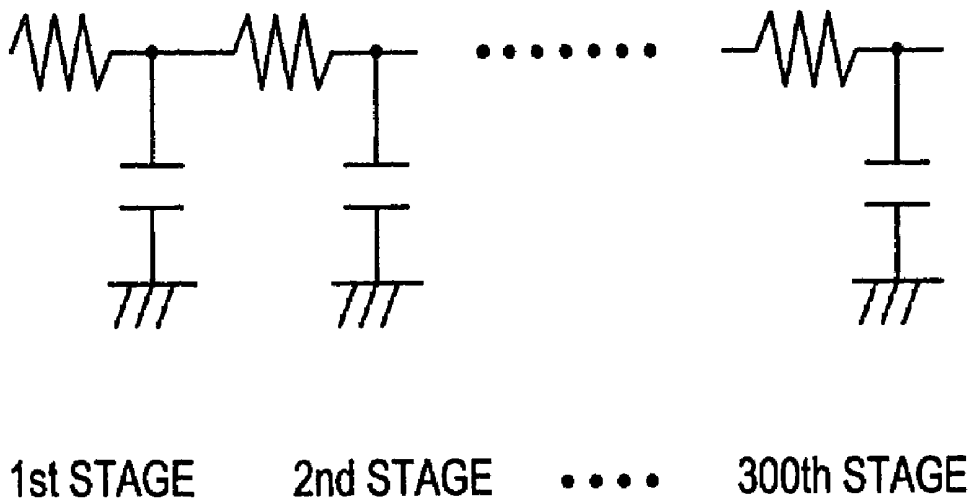

FIG. 9

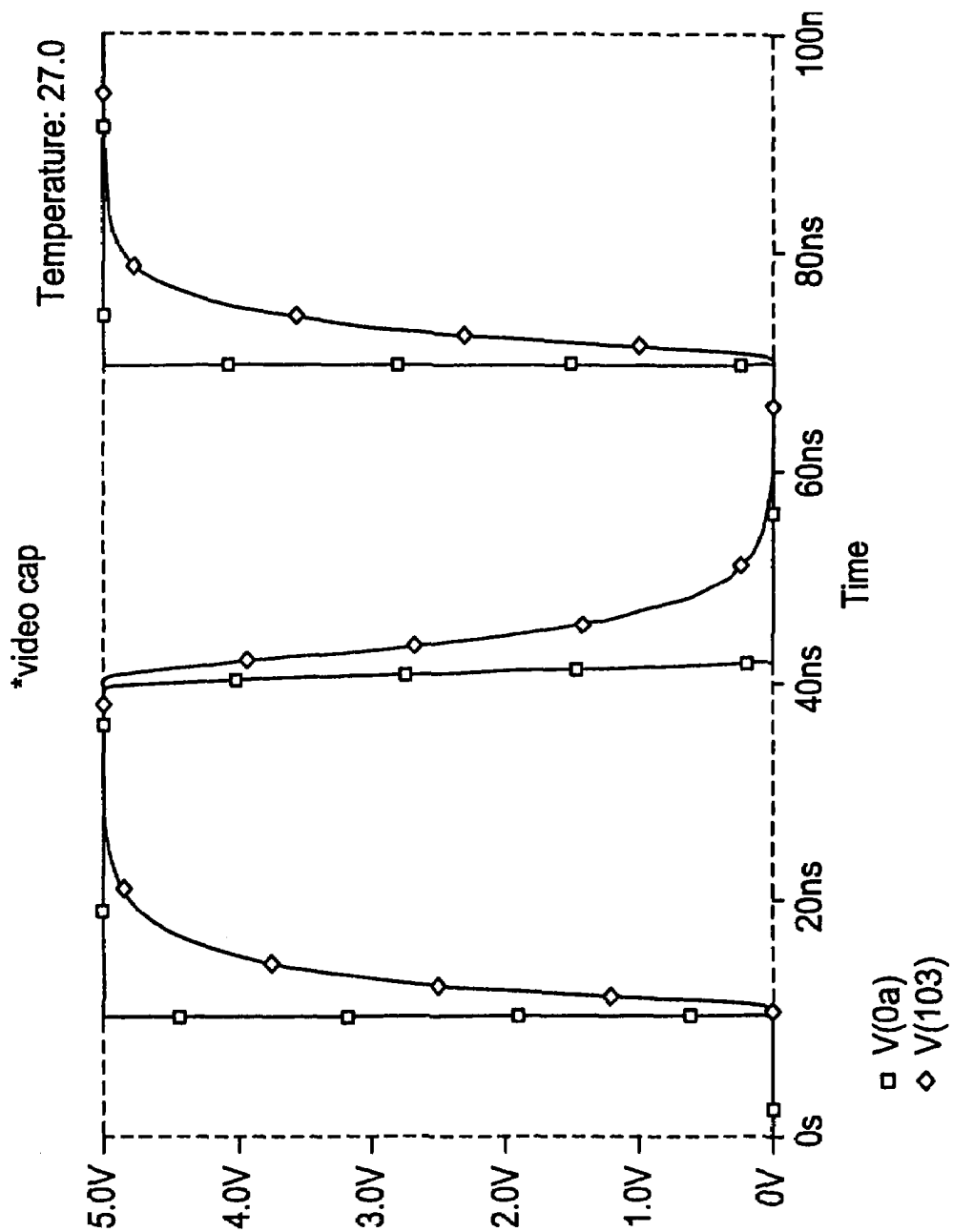

FIG. 10

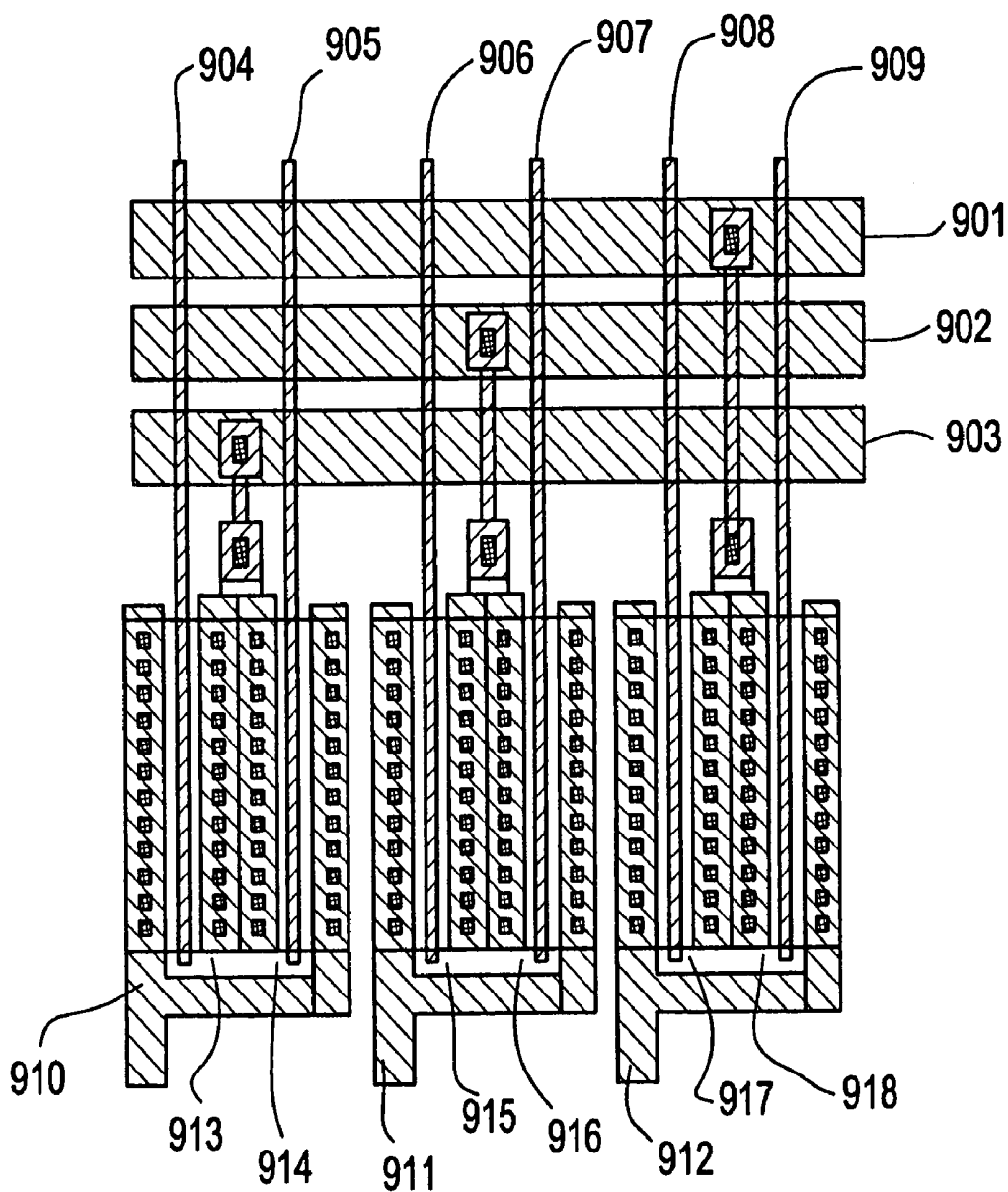

FIG. 11

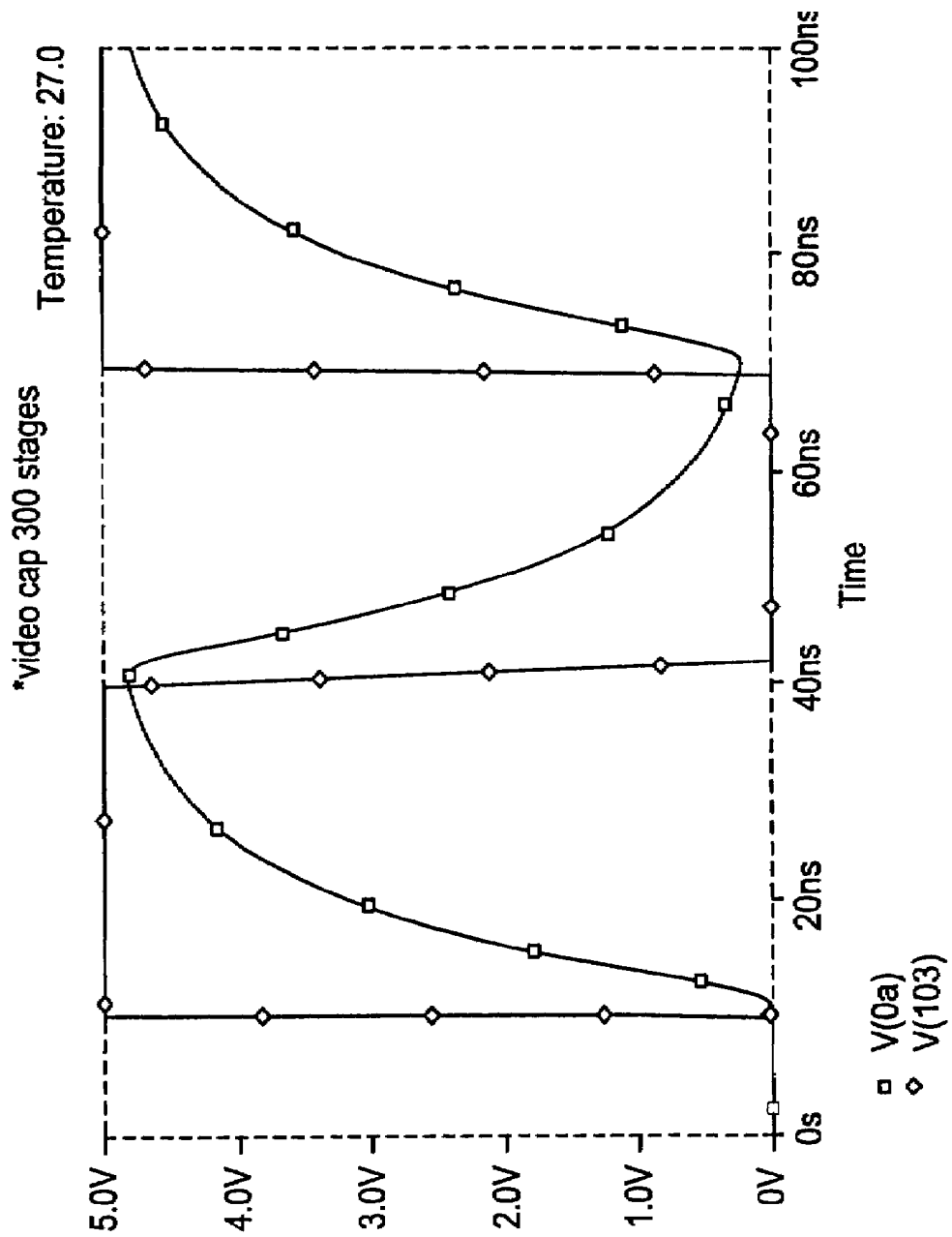

FIG. 12A

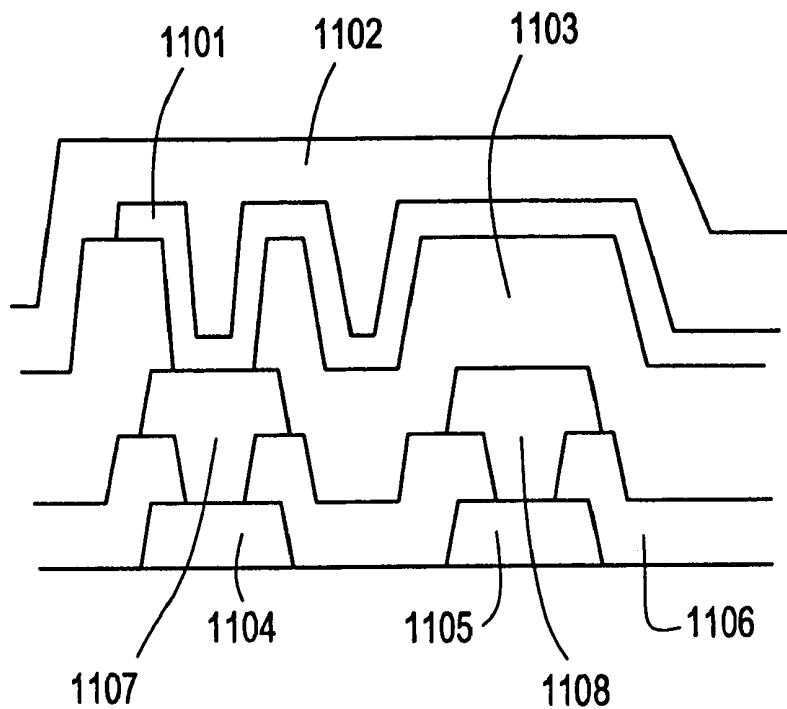

FIG. 12B

PRIOR ART

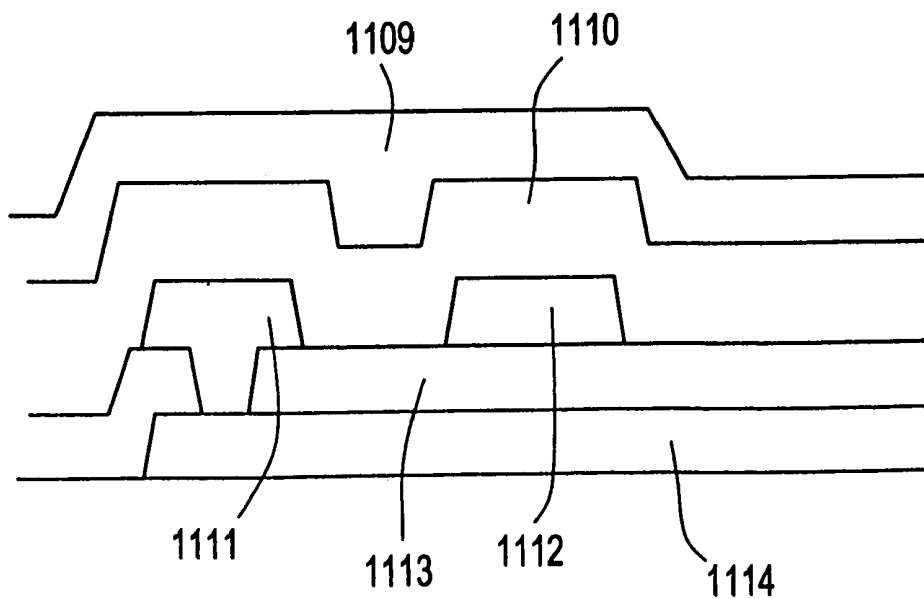

FIG. 13

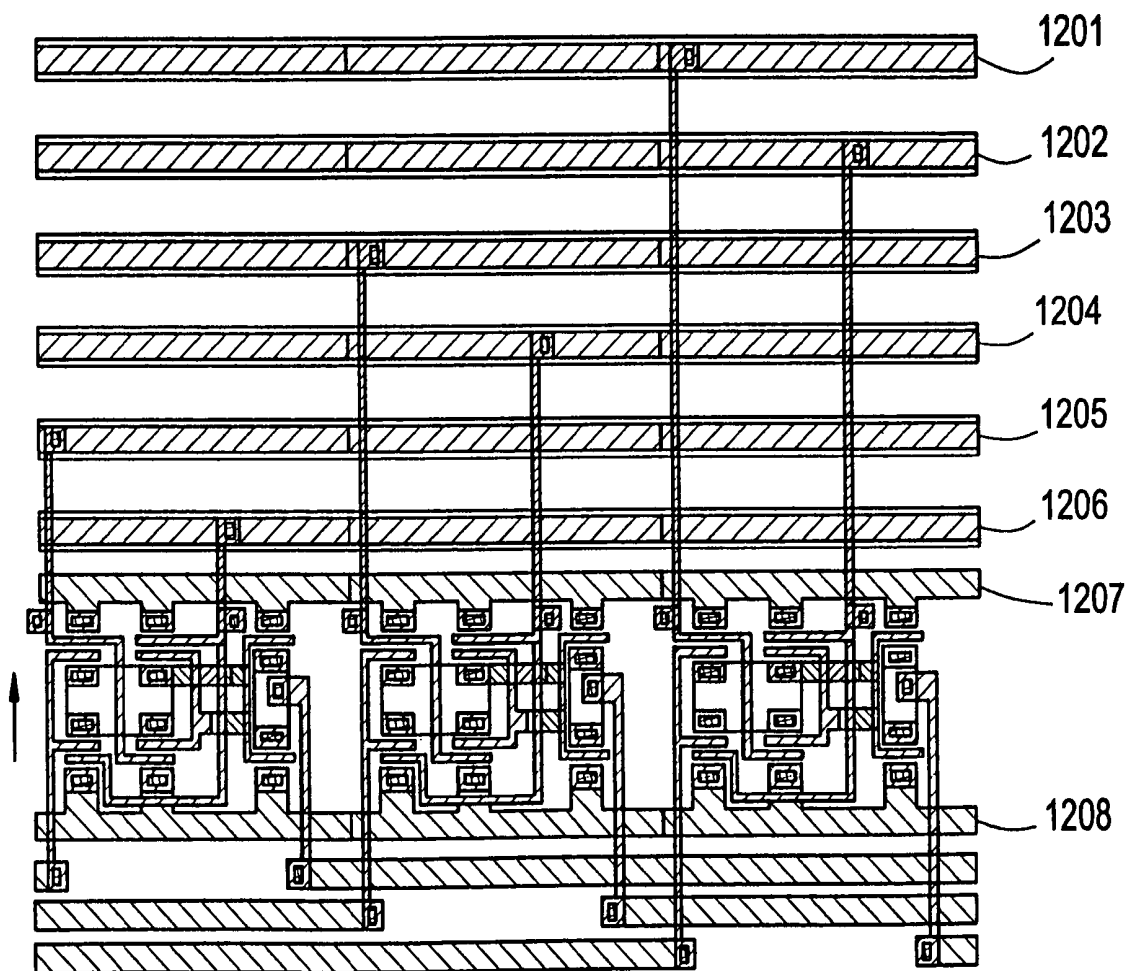

FIG. 14

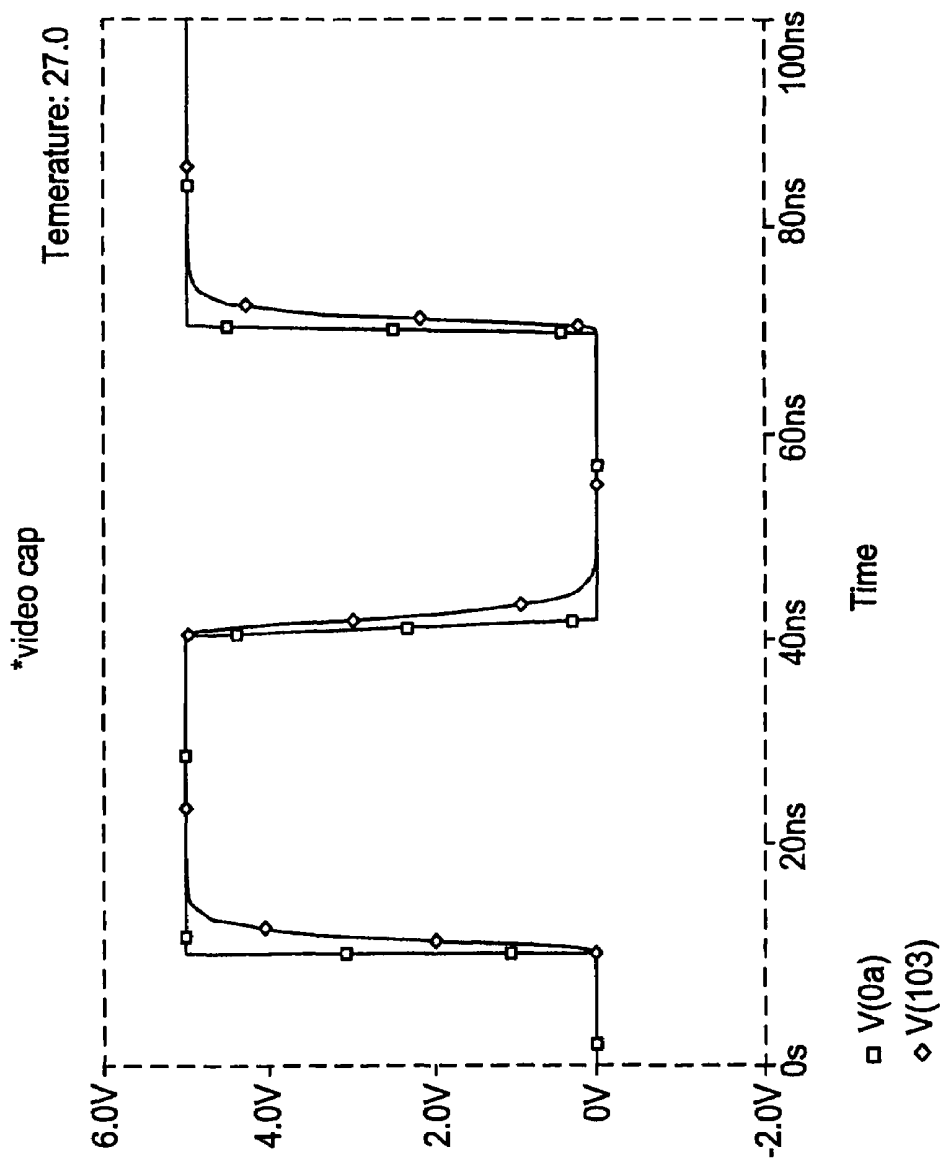

FIG. 15

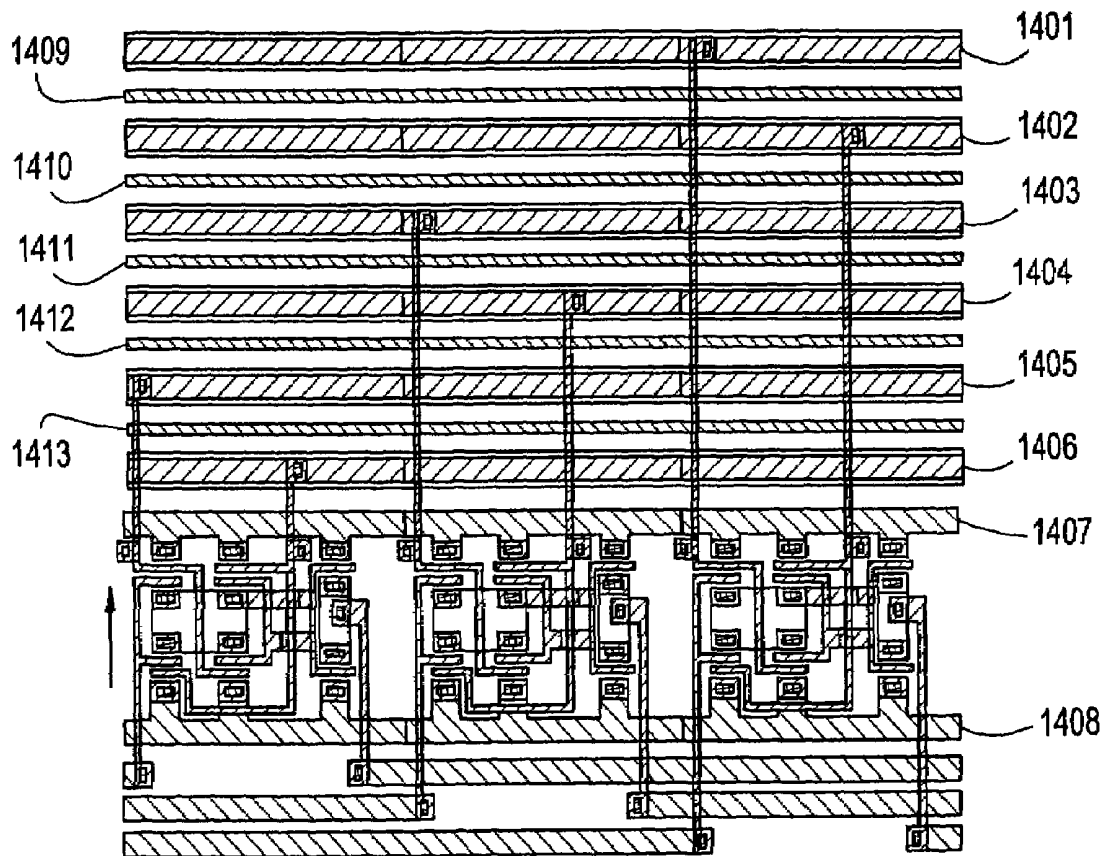

FIG. 16

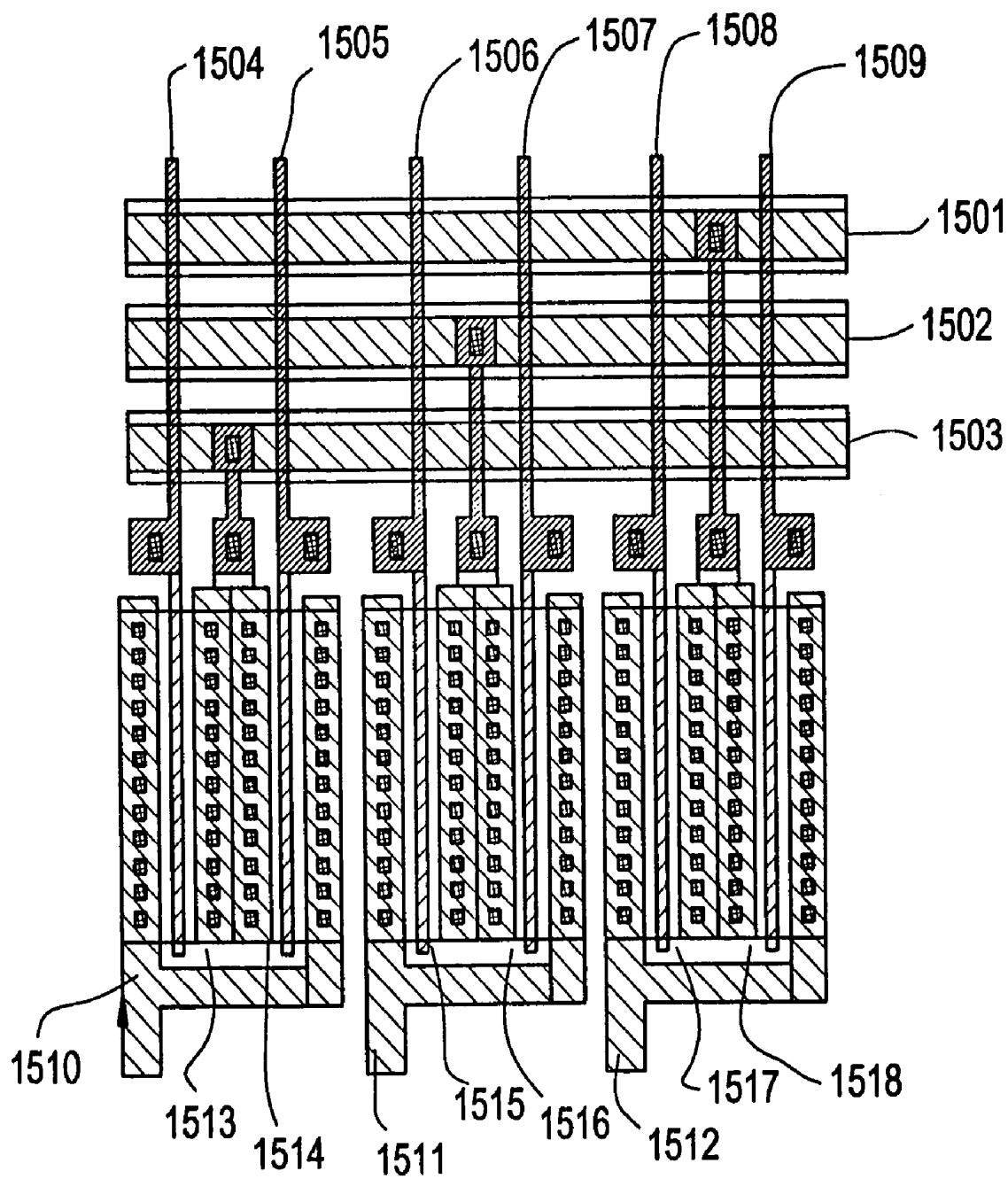
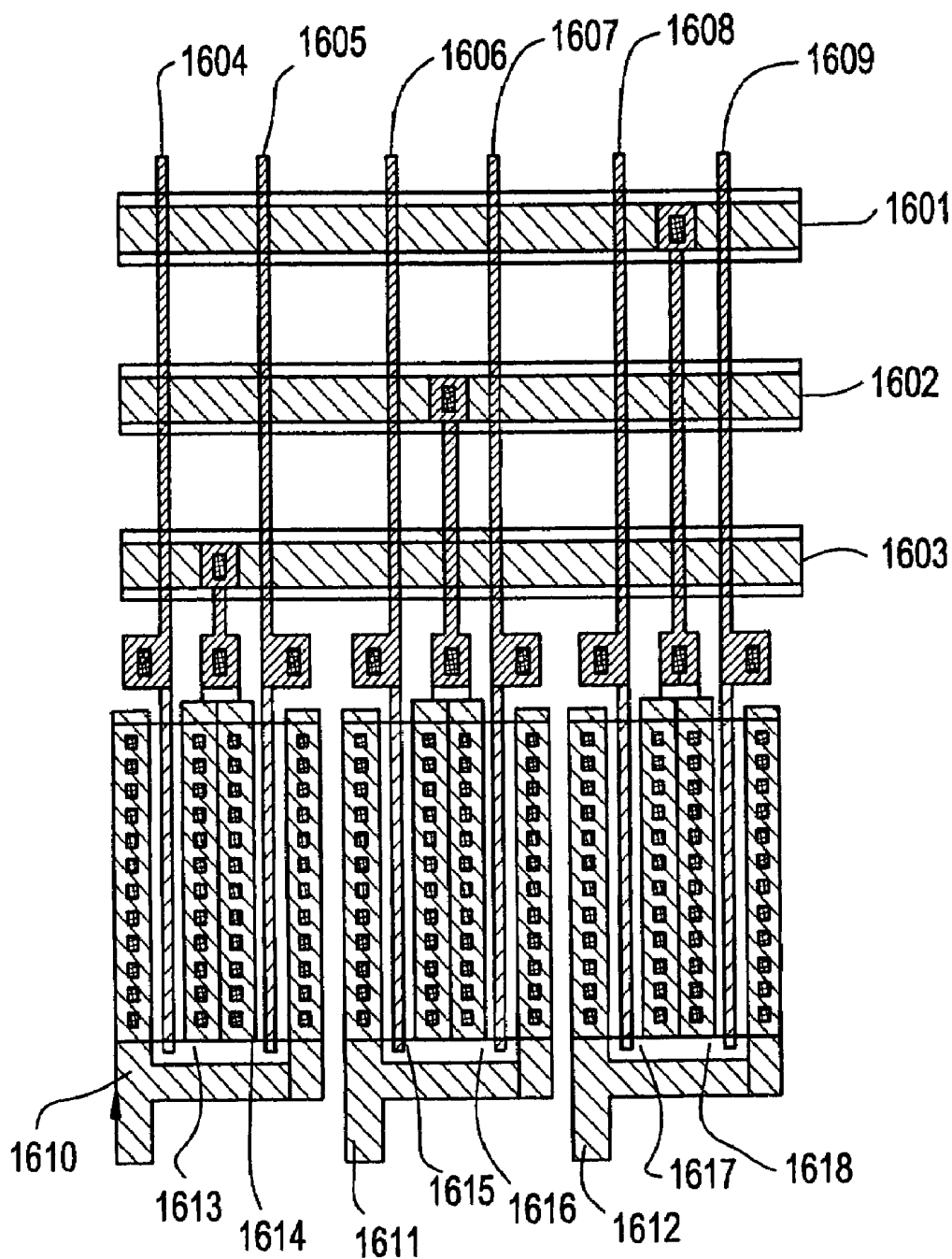

FIG. 17



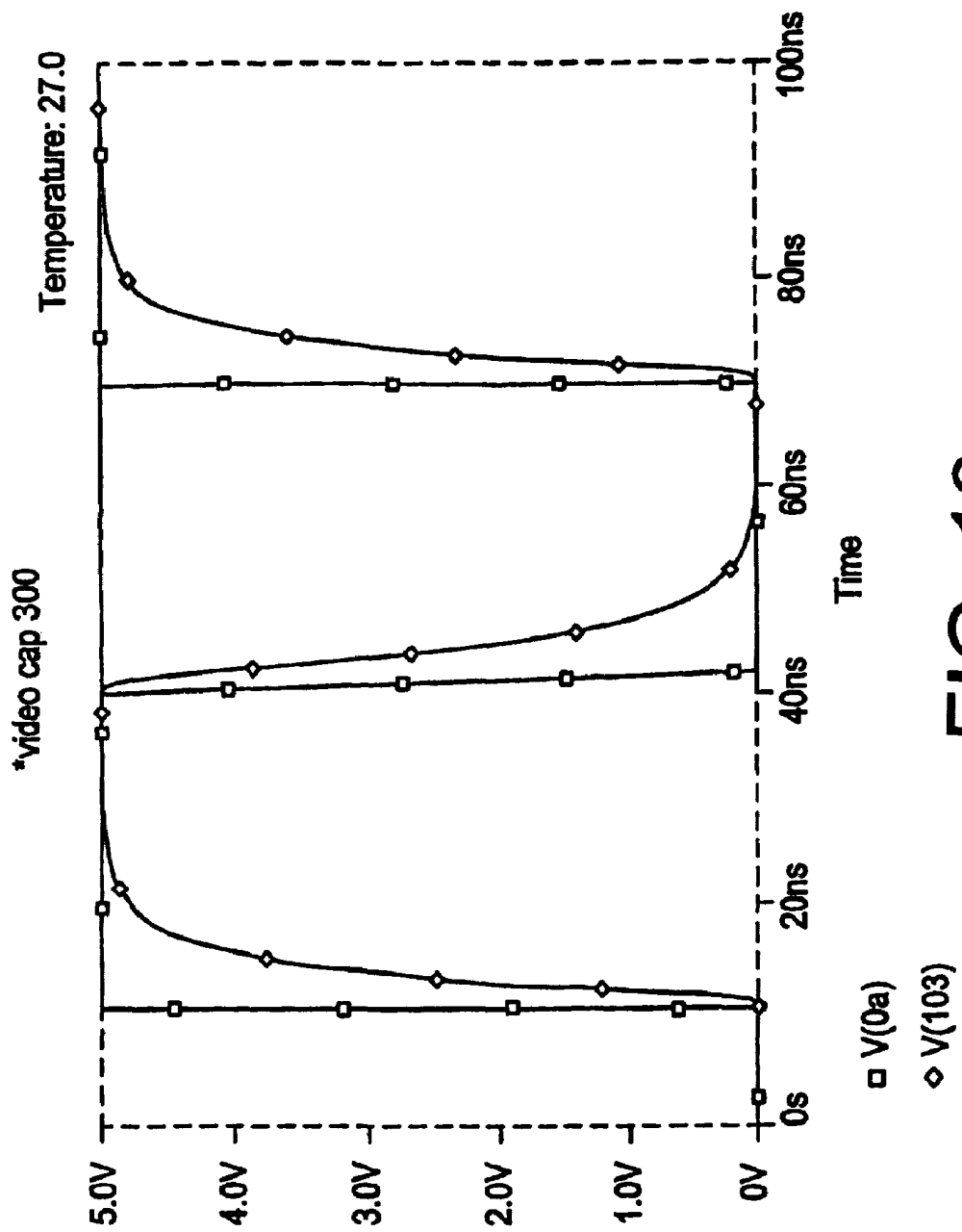
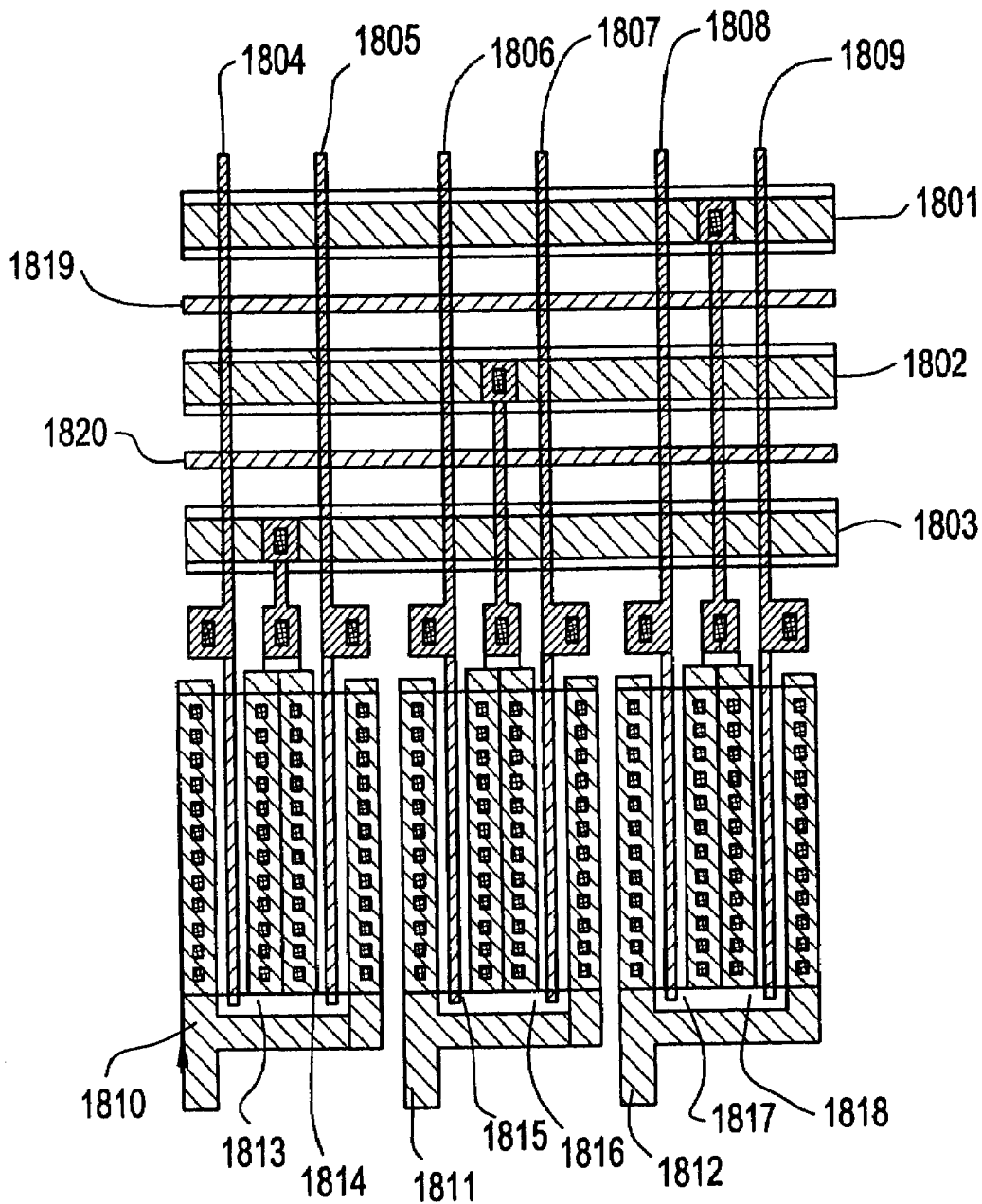

FIG. 18

FIG. 19



DRIVING CIRCUIT OF LIQUID CRYSTAL DISPLAY DEVICE

BACKGROUND OF THE INVENTION

1. Field of the Invention

The present invention relates to a driving circuit of a liquid crystal display device, and particularly to a driving circuit for driving signal lines.

2. Description of the Related Art

As a liquid crystal display device having a built-in driving circuit for signal lines and scan lines, there is known a device manufactured by using thin film transistors made of polysilicon.

FIG. 2 is a schematic view showing a conventional liquid crystal display device having a built-in driving circuit.

In FIG. 2, signal lines **206**, **207** and **208** are arranged in the row direction, scanning lines **203**, **204** and **205** are arranged in the column direction, and pixel transistors **224** and **225** are arranged in matrix at intersection points of those lines. A gate terminal of the thin film transistor **224** is connected to the scanning line **203**, a source terminal thereof is connected to the signal line **206**, and a drain terminal thereof is connected to a pixel electrode **226**.

Each of the signal lines is designed to input a video signal inputted from a video input terminal to the source terminal of the pixel transistor, and is driven by a signal line driving circuit **201**. Each of the scan lines is designed to input a scanning signal to the gate terminal of the pixel transistor and is driven by a scan line driving circuit **202**.

The signal line driving circuit **201** is constituted by a shift register **216** and analog switches **218**, **219** and **220**. This system is called dot-sequential driving, and is common in a liquid crystal display device having a built-in driving circuit.

The shift register includes an input terminal **215** for inputting a start pulse, clock input terminals **208** and **209** for sequentially shifting a pulse, and power supply terminals **213** and **214**. The outputs **221**, **222** and **223** of the shift register are connected to the analog switches **218**, **219** and **220**.

FIG. 3 shows operation waveforms of the shift register.

When clock pulses CL1 and CL1b are inputted, a start pulse is shifted according to rising and falling of the clock.

As a result, an analog switch selection pulse is outputted to the respective outputs of the shift register.

This output is inputted to the analog switches **218**, **219** and **220**, and the respective analog switches are turned on only during the period of the pulse. When the analog switch is turned on, the video line **210**, **211**, or **212** and the signal line **206**, **207** or **208** at both ends of the analog switch are short-circuited during the period, and data of the video line are written into the signal line. The data written into the signal line are inputted into pixel transistor connected to the selected scan line and are written into the pixel electrode.

The transmittance of a liquid crystal is changed by voltage between the pixel electrode and the opposite substrate so that gradation display is made.

FIGS. 4 and 5 show manufacturing steps of a conventional liquid crystal display device.

Manufacturing steps of obtaining a conventional monolithic type active matrix circuit will be described below with reference to FIGS. 4 and 5. The steps relate to a low temperature polysilicon process. The left sides of FIGS. 4 and 5 show manufacturing steps of a TFT of a driving circuit and the right sides thereof show manufacturing steps of a TFT of an active matrix circuit, respectively.

First, a silicon oxide film with a thickness of 1000 to 3000 Å is formed as an underlayer oxide film **402** on a glass substrate **401**. As a method of forming the silicon oxide film, it is appropriate to use a sputtering method or a plasma CVD method in an oxygen atmosphere.

Then an amorphous silicon film with a thickness of 300 to 1500 Å, preferably 500 to 1000 Å is formed by a plasma CVD method or an LPCVD method. Then heat annealing is carried out at a temperature of 500° C. or more, preferably 500 to 600° C. to crystallize the silicon film or to raise crystallinity thereof. The crystallinity may further be raised by light (laser or the like) annealing after the crystallization by the heat annealing.

Moreover, at the crystallization by the heat annealing, an element (catalytic element) for promoting crystallization of silicon may be added as disclosed in Japanese Patent Unexamined Publication No. Hei. 6-244103 and No. Hei. 6-244104.

Next, the silicon film is etched to form an active layer **403** (for a P-channel TFT) and an active layer **404** (for an N-channel TFT) of the island-like driving circuit, and an active layer **405** of a TFT (pixel TFT) of the matrix circuit. Further, a gate insulating film of silicon oxide with a thickness of 500 to 2000 Å is formed by a sputtering method in an oxygen atmosphere. A plasma CVD method may be used for the method of forming the gate insulating film. In the case where the silicon oxide film is formed by the plasma CVD method, it was preferable to use nitrous oxide (N₂O) or oxygen (O₂) and monosilane (SiH₄) as a raw material gas.

Thereafter, aluminum with a thickness of 2000 to 6000 Å is formed on the entire surface of the substrate by a sputtering method. Here, aluminum may contain silicon, scandium, palladium, or the like so as to prevent hillocks from occurring by a subsequent thermal process. This is etched to form gate electrodes **407**, **408** and **409** (FIG. 4A).

Next, this aluminum is subjected to anodic oxidation. The surfaces of the aluminum become aluminum oxides **410**, **411**, and **412** by the anodic oxidation so that they come to have effects as insulators (FIG. 4B).

Next, a mask **413** of photoresist covering the active layer of the P-channel TFT is formed. Then phosphorus is implanted by an ion doping method with phosphine as a doping gas. The dosage is made 1×10^{12} to 5×10^{13} atoms/cm². As a result, high N-type regions (source, drain) **414** and **415** are formed (FIG. 4C).

Next, a mask **416** of photoresist covering the active layer of the N-channel TFT and the active layer of the pixel TFT is formed. Then boron is implanted again by an ion doping method with diborane (B₂H₆) as a doping gas. The dosage is made 5×10^{14} to 8×10^{15} atoms/cm². As a result, P-type regions **417** are formed. By the above doping steps, the high N-type regions (source, drain) **414** and **415**, and the high P-type regions (source, drain) **417** are formed (FIG. 4D).

Thereafter, heat annealing at 450 to 850° C. for 0.5 to 3 hours is carried out to repair damages produced by doping and to activate doping impurities so that crystallinity of silicon is recovered. Then a silicon oxide film with a thickness of 3000 to 6000 Å is formed as an interlayer insulating film **418** on the entire surface by a plasma CVD method. This film may be a silicon nitride film or a multilayer film of a silicon oxide film and a silicon nitride film. Then the interlayer insulating film **418** is etched by a wet etching method or a dry etching method to form contact holes to the source/drain.

Then an aluminum film or a multilayer film of titanium and aluminum with a thickness of 2000 to 6000 Å is formed by a sputtering method. This film is etched to form electrode/

wiring lines **419**, **420**, and **421** of the peripheral circuit and electrode/wiring lines **422** and **423** of the pixel TFT (FIG. 5E).

Further, polyimide with a thickness of 10000 Å is applied to form a second interlayer film **424**. Next, titanium with a thickness of 2000 to 3000 Å is formed and is etched to form a black matrix **426** on the TFT. Further, polyimide with a thickness of 5000 to 6000 Å is applied to form a third interlayer film. Next, the second and third interlayer films are etched to form a contact hole reaching the electrode **423** of the TFT. Finally, an ITO (indium-tin oxide) film formed by a sputtering method and having a thickness of 500 to 1500 Å is etched to form a pixel electrode **425**. In this way, the peripheral driving circuit and the active matrix circuit are integrally formed (FIG. 5F).

FIG. 6 shows a pattern of a conventional shift register. Numerals **501** to **506** indicate clock lines and numerals **507** and **508** indicate power supply terminals, respectively.

In a driving circuit of a conventional liquid crystal display device, in the case where clock wiring lines, video signal wiring lines, and control wiring lines of a shift register are formed, those wiring lines are formed at the same time as source and drain electrodes of a thin film transistor. The source/drain electrodes are used because the sheet resistance thereof is normally lower than a gate electrode material. In general, aluminum is used for the source/drain electrodes and the sheet resistance thereof is 0.1 Ω to 0.2 Ω.

As parasitic capacitance added to those wiring lines, inter-wiring capacitance between other wiring lines, and cross capacitance are conceivable. The inter-wiring capacitance has relation shown in FIG. 7, and as an interval between wiring lines becomes wide, the capacitance becomes small.

In the case where it is desired to raise frequencies of signals to be transmitted through the clock lines, video lines, control signal lines and the like, the foregoing wiring resistance and parasitic capacitance lower the frequency characteristics, which becomes a problem.

Here, it is assumed that the shift register shown in FIG. 6 has 300 stages, one stage being 250 μm. The explanation will be hereinafter made under this condition.

In the forgoing case where a wiring line and other wiring line cross each other, it is general to make crossing with gate electrode wiring lines. In this case, first interlayer film capacitance becomes parasitic capacitance.

When the interlayer film is formed of an oxide film with a thickness of 5000 Å and the width of a cross wiring line is 5 μm, the parasitic capacitance is 0.069 fF/μm²*5 μm*30 μm=10.3 fF. When there are 1.66 cross points for the foregoing wiring line of 250 μm, parasitic capacitance of 10.3 fF*1.66=17.1 fF is generated. Besides, when the interval of wiring lines is 5 μm, the inter-wiring capacitance becomes 0.063 fF/μm*250 μm*2=31.5 fF per 250 μm. In total, capacitance becomes 48.6 fF.

FIG. 9 shows the result of simulation for a delay amount under the assumption that the shift register is equivalent to a 300-stage resistor/capacitor ladder circuit shown in FIG. 8. The delay time is 2.8 ns, and in the case where the frequency is ten and several MHz, the rate of delay is 5%.

The same is true for a video signal line subjected to sampling by an analog switch. FIG. 10 is a plan view showing a conventional analog switch. Numerals **901** to **903** are denoted as video signal lines, numerals **904** to **909** are denoted as outputs of the shift register, numerals **910** to **912** are denoted as signal lines, and numerals **913** to **918** are denoted as analog switch transistor, respectively.

It is assumed that RGB three colors are made one, a pitch is 300 μm, and the number of stages is 300. When the wiring width is 30 μm, 300 μm, the wiring resistance becomes 2 Ω.

Similarly to the shift register, in the case where the video signal line and other wiring line cross each other, it is general that crossing is made at gate electrode wiring lines. In this case, interlayer film capacitance becomes parasitic capacitance.

When the interlayer film is formed of an oxide film with a thickness of 500 nm and the width of the cross wiring line is 5 μm, parasitic capacitance is 0.069 fF/μm²*5 μm*30 μm=10.3 fF. If 8 cross points exist for the video signal line of 300 μm, the parasitic capacitance of 10.3 fF*8=82.8 fF is generated. The inter-wiring capacitance becomes 37.8 fF, and the total capacitance becomes 120.6 fF per 300 μm.

FIG. 11 shows the result of simulation of a delay amount similarly to the clock line. The delay time was 8.25 ns, and the delay was larger than the clock line.

In the case where the delay time is large or wiring capacitance is large, the following become problems for a display device.

(1) A time delay in a clock line causes a shift delay in shift of a shift register by the amount of the delay. Moreover, not only a clock delay but also waveform distortion is generated, which causes inferior operation of the shift register. The distortion in a video signal line causes the same data to be written in plural columns on a picture screen or pixels to be blurred, so that the picture quality is degraded.

(2) When inter-wiring capacitance becomes large, mutual interference between clock lines, and mutual interference between video signal lines are generated, which also causes the deterioration of picture quality.

(3) When the inter-wiring capacitance becomes large, and in the case where the clock line and video signal line are driven from the outside, large driving power of an external driving circuit is required and the consumption of electricity also becomes large.

As the capacitance load becomes large, the external driving circuit becomes large and the cost is increased. When a feedback amplifier such as an operational amplifier is used for the external driving circuit, erroneous operations such as oscillation are induced by the capacitance load, which also causes the deterioration of picture quality.

SUMMARY OF THE INVENTION

The present invention has been made in view of the above problems, and an object of the present invention is to provide a driving circuit of a liquid crystal display device in which a shift in timing is small, high picture quality can be provided, a load on an external circuit is lightened, and consumption of electricity is reduced.

According to an aspect of the present invention, a driving circuit of a liquid crystal display device comprising a first insulating substrate on which a plurality of signal lines and a plurality of scan lines are disposed, and pixel transistors made of thin film transistors are disposed in matrix at intersection points of those lines; a second insulating substrate opposite to the first insulating substrate; and a liquid crystal held between the first and second insulating substrates,

wherein the driving circuit is disposed on the first insulating substrate; each of clock lines or base portions of the clock lines for supplying clock signals to the driving circuit is made of a two-layer structure of the same wiring material as a gate electrode of the thin film transistor and the same wiring material as a source electrode or a drain electrode of

the thin film transistor; and a wiring line crossing the clock lines or the base portions of the clock lines is made of a wiring line in the same layer as a black matrix covering the pixel transistors.

According to another aspect of the present invention, a driving circuit of a liquid crystal display device comprising a first insulating substrate on which a plurality of signal lines and a plurality of scan lines are disposed, and pixel transistors made of thin film transistors are disposed in matrix at intersection points of those lines; a second insulating substrate opposite to the first insulating substrate; and a liquid crystal held between the first and second insulating substrates,

wherein the driving circuit is disposed on the first insulating substrate; each of clock lines or base portions of the clock lines for supplying clock signals to the driving circuit is made of a two-layer structure of the same wiring material as a gate electrode of the thin film transistor and the same wiring material as a source electrode or a drain electrode of the thin film transistor; a wiring line crossing the clock lines or the base portions of the clock lines is made of a wiring line in the same layer as a black matrix covering the pixel transistors; and a wiring interval between adjacent ones of the clock wiring lines or the base portions of the clock wiring lines is wider than a width of each of the clock wiring lines or the base portions of the clock wiring lines.

According to still another aspect of the present invention, a driving circuit of a liquid crystal display device comprising a first insulating substrate on which a plurality of signal lines and a plurality of scan lines are disposed, and pixel transistors made of thin film transistors are arranged in matrix at the intersection points of those lines; a second insulating substrate opposite to the first insulating substrate; and a liquid crystal held between the first and second insulating substrates,

wherein the driving circuit is formed on the first insulating substrate; a plurality of clock lines for supplying clock signals to the driving circuit are disposed; and a shield line biased at a fixed potential is disposed between the clock lines or base portions of the clock lines.

According to yet another aspect of the present invention, a driving circuit of a liquid crystal display device comprising a first insulating substrate on which a plurality of signal lines and a plurality of scan lines are disposed, and pixel transistors made of thin film transistors are disposed in matrix at intersection points of those lines; a second insulating substrate opposite to the first insulating substrate; and a liquid crystal held between the first and second insulating substrates,

wherein the driving circuit is formed on the first insulating substrate; each of video signal lines or base portions of the video signal lines for supplying video signals to the driving circuit is made of a two-layer structure of the same wiring material as a gate electrode of the thin film transistor and the same wiring material as a source electrode or drain electrode of the thin film transistor; and a wiring line crossing the video signal lines or the base portions of the video signal lines is made of a wiring line in the same layer as a black matrix covering the pixel transistors.

According to another aspect of the present invention, a driving circuit of a liquid crystal display device comprising a first insulating substrate on which a plurality of signal lines and a plurality of scan lines are disposed, and pixel transistors made of thin film transistors are disposed in matrix at intersection points of those lines; a second insulating sub-

strate opposite to the first insulating substrate; and a liquid crystal held between the first and second insulating substrates,

wherein the driving circuit is formed on the first insulating substrate; each of video signal lines or base portions of the video signal lines for supplying video signals to the driving circuit is made of a two-layer structure of the same wiring material as a gate electrode of the thin film transistor and the same wiring material as a source electrode or drain electrode of the thin film transistor; a wiring line crossing the video signal lines or the base portions of the video signal lines is made of a wiring line in the same layer as a black matrix covering the pixel transistors; and a wiring interval between adjacent ones of the video signal lines or the base portions of the video signal lines is wider than a width of each of the video signal lines or the base portions of the video signal lines.

According to still another aspect of the present invention, a driving circuit of a liquid crystal display device comprising a first insulating substrate on which a plurality of signal lines and a plurality of scan lines are disposed, and pixel transistors made of thin film transistors are disposed in matrix at intersection points of those lines; a second insulating substrate opposite to the first insulating substrate; and a liquid crystal held between the first and second insulating substrates,

wherein the driving circuit is formed on the first insulating substrate; a plurality of video signal lines for supplying video signals to the driving circuit are disposed; and a shield line biased at a fixed potential is disposed between the plurality of video signal lines or base portions of the video signal lines.

The driving circuit of the liquid crystal display device according to the present invention has the following effects.

1. With respect to the clock lines, the wiring line is made of the two-layer structure of the gate electrode material and the source/drain electrode material, and other wiring line crossing the clock lines is made in the same layer as the black matrix, so that the wiring resistance and parasitic capacitance can be reduced and the frequency characteristics can be improved.

2. With respect to the clock lines, the wiring interval is made wider than the wiring width, so that the inter-wiring capacitance can be reduced and the frequency characteristics can be improved.

3. With respect to the clock lines, the shield line is disposed between wiring lines so that the mutual interference between the wiring lines can be reduced.

4. With respect to the video signal lines, the wiring line is made of the two-layer structure of the gate electrode material and the source/drain electrode material, and other wiring line crossing the video signal lines is made in the same layer as the black matrix, so that the wiring resistance and parasitic capacitance can be reduced and the frequency characteristics can be improved.

5. With respect to the video signal lines, the wiring interval is made wider than the wiring width, so that the inter-wiring capacitance can be reduced and the frequency characteristics can be improved.

6. With respect to the video signal lines, the shield line is disposed between wiring lines so that the mutual interference between the wiring lines can be reduced.

BRIEF DESCRIPTION OF THE DRAWINGS

In the accompanying drawings:

FIG. 1 is a view showing a first embodiment (shift register) of the present invention;

FIG. 2 is a schematic view showing a conventional liquid crystal display device;

FIG. 3 is a view showing operation waveforms of a shift register;

FIGS. 4A to 4D are sectional views showing manufacturing steps of a conventional liquid crystal display device;

FIGS. 5A and 5B are sectional views showing the manufacturing steps;

FIG. 6 is a plan view showing a conventional shift register;

FIG. 7 is a graph showing the relation between inter-wiring capacitance and wiring interval;

FIG. 8 is a view showing a simulation circuit for a wiring delay time;

FIG. 9 is a view showing the result of wiring delay time simulation of a conventional shift register;

FIG. 10 is a plan view showing a conventional analog switch;

FIG. 11 is a view showing the result of wiring delay time simulation of a conventional analog switch;

FIG. 12A is a sectional view showing a wiring line of the present invention;

FIG. 12B is a sectional view showing a wiring line of the prior art;

FIG. 13 is a view showing a second embodiment (shift register) of the present invention;

FIG. 14 is a view showing the result of simulation of the second embodiment;

FIG. 15 is a view showing a third embodiment (shift register) of the present invention;

FIG. 16 is a view showing a fourth embodiment (analog switch) of the present invention;

FIG. 17 is a view showing a fifth embodiment (analog switch) of the present invention;

FIG. 18 is a view showing the result of simulation of the fifth embodiment; and

FIG. 19 is a view showing a sixth embodiment (analog switch) of the present invention.

DETAILED DESCRIPTION OF THE PREFERRED EMBODIMENTS

Preferred embodiment of the present invention will now be described below.

Embodiment 1

FIG. 12A is a sectional view showing a clock wiring portion of a driving circuit using the present invention. As compared with the prior art (shown in FIG. 12B), clock wiring lines are made of two layers of gate electrodes **1104** and **1105** and source electrodes **1107** and **1108**, so that wiring resistance becomes low. Moreover, since a cross wiring line is changed from a gate electrode wiring line **1114** in FIG. 12B to a black matrix wiring line **1101** in FIG. 12A, an interlayer film which forms parasitic capacitance is changed from a first interlayer film **1113** in FIG. 12B to a second interlayer film **1103** in FIG. 12A. Thus, the interlayer film becomes thick two times and the capacitance is reduced. Also, numerals **1102** and **1106** indicate a third interlayer film and first interlayer film in FIG. 12A and numerals **1109**,

1110, **1111**, and **1112** are denoted as a third interlayer film, a second interlayer film, and source electrodes in FIG. 12B, respectively.

FIG. 1 is a plan view showing a shift register portion of the first embodiment. Numerals **101** to **106** indicate clock lines and numerals **107** and **108** indicate power supply terminals, respectively.

As described before, the sheet resistance of source/drain electrodes is 0.2Ω , and the sheet resistance of a gate electrode is 0.3Ω . A clock line is made of a wiring line of a source electrode material with a width of $30 \mu\text{m}$ and a wiring line of a gate electrode material with a width of $20 \mu\text{m}$ under the wiring line of the source electrode material.

In the case where one stage of a shift register is made $250 \mu\text{m}$ like the prior art, the resistance of the clock line per one stage becomes 1.15Ω .

With respect to a wiring delay at this time, the inter-wiring capacitance between wiring lines per one stage is not changed, and the wiring cross capacitance is almost halved by using the same layer as a black matrix for a cross wiring line, so that a delay time at the end of the wiring is 1.62 ns . As compared with the prior art, the improvement of 42% can be seen.

Embodiment 2

FIG. 13 is a plan view showing a shift register portion of a driving circuit of a liquid crystal display device according to embodiment 2. Numerals **1201** to **1206** indicate clock lines and numerals **1207** and **1208** indicate power supply terminals, respectively. As compared with the prior art (FIG. 6) and the embodiment 1, the interval between clock wiring lines is widened so that the inter-wiring capacitance is reduced. When the distance between the wiring lines is changed from $5 \mu\text{m}$ to $40 \mu\text{m}$, the inter-wiring capacitance between wiring lines becomes $0.32 \text{ fF}/\mu\text{m}$. When the wiring length is $250 \mu\text{m}$, the inter-wiring capacitance of 16.0 fF is generated. The total capacitance including the cross capacitance becomes 24.6 fF . At this time, the delay time at the wiring end of connection of 300 stages is 1.02 ns . As compared with the prior art, the improvement of 64% can be seen.

FIG. 14 shows the simulation result of a clock delay time.

Embodiment 3

FIG. 15 is a plan view showing a shift register portion of the embodiment 3. Numerals **1401** to **1406** indicate clock lines, numerals **1407** and **1408** indicate power supply terminals, and numerals **1409** to **1413** indicate shield lines, respectively.

In this embodiment, a shield line at a fixed potential is disposed between clock lines. Although inter-wiring capacitance is newly generated with respect to the shield line, the capacitance between the clock lines is reduced and mutual interference between clock signals can be reduced.

Embodiment 4

FIG. 16 is a plan view showing an analog switch of embodiment 4. Numerals **1501** to **1503** indicate video signal lines, numerals **1504** to **1509** indicate outputs of the shift register, numerals **1510** to **1512** indicate signal lines, and numerals **1513** to **1518** indicate analog switch transistors, respectively.

Like the shift register, as compared with the prior art (FIG. 10), the video signal lines **1501** to **1503** are made of two

layers of gate electrodes and source electrodes, so that wiring resistance becomes small. With respect to the wiring, like the shift register, the sheet resistance of source/drain electrodes is 0.2Ω as described before, and the sheet resistance of the gate electrode is 0.3Ω . The video signal line is made of a wiring line of the source electrode material with a width of $30 \mu\text{m}$ and a wiring line of the gate electrode material with a width of $20 \mu\text{m}$ under the wiring line of the source electrode material.

Similarly to the prior art, in the case where the analog switch is made $300 \mu\text{m}$, the resistance of the video signal line per one stage becomes 1.38Ω . The wiring cross capacitance is almost halved by using the same layer as a black matrix for a cross wiring line, and becomes 41.4 fF . The delay time at the wiring end is 3.75 ns .

The improvement of 55% as compared with the prior art can be seen.

Embodiment 5

FIG. 17 is a plan view showing an analog switch of embodiment 5. Numerals 1601 to 1603 indicate video signal lines, numerals 1604 to 1609 indicate outputs of the shift register, numerals 1610 to 1612 indicate signal lines, and numerals 1613 to 1618 indicate analog switch transistors, respectively.

As compared with the prior art (FIG. 10) and the embodiment 4, the interval between video signal lines is widened, so that the inter-wiring capacitance between wiring lines becomes small. When the distance between the wiring lines is changed from $5 \mu\text{m}$, which is a conventional value, to $40 \mu\text{m}$, the inter-wiring capacitance becomes $0.032 \text{ fF}/\mu\text{m}$ as shown in FIG. 7. When the wiring length is $300 \mu\text{m}$, the inter-wiring capacitance of 19.2 fF is generated. The total capacitance including the cross capacitance is 60.6 fF . A delay time at the wiring end of connection of 300 stages is 2.88 ns . As compared with the prior art, the improvement of 65% can be seen.

FIG. 18 shows the simulation result of a delay time of a video signal.

Embodiment 6

FIG. 19 is a plan view showing an analog switch of embodiment 6. Numerals 1801 to 1803 indicate video signal lines, numerals 1804 to 1809 indicate outputs of the shift register, numerals 1810 to 1812 indicate signal lines, numerals 1813 to 1818 indicate analog switch transistors, and numerals 1819 to 1820 indicate shield lines, respectively.

In this embodiment, a shield line at a fixed potential is disposed between video signal lines. Although the inter-wiring capacitance with respect to the shield line is newly generated, the capacitance between video signal lines is reduced and the mutual interference between video signals can be reduced.

As described above, in the driving circuit of the liquid crystal display device according to the present invention, each of clock lines, video signal lines, and control signal lines is made of a two-layer structure of a gate electrode material and a source/drain electrode material, so that wiring resistance is lowered. Moreover, a wiring line crossing those wiring lines is made of a wiring material in the same layer as a black matrix on a TFT, so that the parasitic capacitance is reduced. Thus the present invention has an effect that the frequency characteristics can be improved.

Moreover, the present invention has effects that the wiring interval of the clock lines, video signal lines, and the like is

made twice or more the wiring width, so that the inter-wiring capacitance between wiring lines is lowered and the frequency characteristics is improved.

Moreover, a shield line is inserted between clock lines or video signal lines, so that the mutual interference between clock lines or video signal lines can be suppressed.

From these, the picture quality of the display device can be improved.

What is claimed is:

1. A semiconductor device comprising:

a substrate having at least one driving circuit comprising a plurality of thin film transistors, clock lines for supplying clock signals to the driving circuit, at least one wiring line crossing the clock lines, a first insulating film and a second insulating film,

wherein each of the clock lines or each of base portions of the clock lines is made of a two-layer structure, a lower layer of said two-layer structure comprising the same wiring material as gate electrodes of the thin film transistors, and an upper layer of said two-layer structure comprising the same wiring material as source and drain electrodes of the thin film transistors,

wherein said wiring line is formed over the first and second insulating films,

wherein said upper layer is formed between the first and second insulating films, and

wherein said lower layer extends in a same direction as said upper layer.

2. A device according to claim 1, wherein an interval between adjacent ones of the clock lines is wider than a width of each of the clock lines.

3. A device according to claim 1, wherein said clock lines are connected to a shift register circuit in the driving circuit.

4. A device according to claim 1, further comprising a pixel portion comprising a plurality of thin film transistors on said substrate.

5. A device according to claim 1, wherein said wiring line formed over the upper layer is connected to the upper layer.

6. A device according to claim 1, further comprising black matrices over the thin film transistors, wherein said wiring line is made of the same layer as the black matrices.

7. A semiconductor device comprising:

a substrate having at least one driving circuit comprising a plurality of thin film transistors, clock lines for supplying clock signals to the driving circuit, at least one wiring line crossing the clock lines, a first insulating film and a second insulating film,

wherein each of the clock lines or each of base portions of the clock lines is made of a two-layer structure, a lower layer of said two-layer structure comprising the same wiring material as gate electrodes of the thin film transistors, and an upper layer of said two-layer structure comprising the same wiring material as source and drain electrodes of the thin film transistors,

wherein said wiring line is formed over the first and second insulating films,

wherein said upper layer is formed between the first and second insulating films, and

wherein the second insulating film is thicker than the first insulating film.

8. A device according to claim 7, wherein an interval between adjacent ones of the clock lines is wider than a width of each of the clock lines.

9. A device according to claim 7, wherein said clock lines are connected to a shift register circuit in the driving circuit.

11

10. A device according to claim 7, further comprising a pixel portion comprising a plurality of thin film transistors on said substrate.

11. A device according to claim 7, wherein said wiring line formed over the upper layer is connected to the upper layer.

12

12. A device according to claim 7, wherein said lower layer extends in a same direction as said upper layer.

13. A device according to claim 7, further comprising black matrices over the thin film transistors, wherein said wiring line is made of the same layer as the black matrices.

* * * * *

专利名称(译)	液晶显示装置的驱动电路		
公开(公告)号	US7079121	公开(公告)日	2006-07-18
申请号	US09/928988	申请日	2001-08-15
[标]申请(专利权)人(译)	小山JUN 田中由纪夫 久保田靖 酒井TAMOTSU		
申请(专利权)人(译)	小山JUN 田中由纪夫 久保田靖 酒井TAMOTSU		
当前申请(专利权)人(译)	半导体能源研究所有限公司. 夏普株式会社		
[标]发明人	KOYAMA JUN TANAKA YUKIO KUBOTA YASUSHI SAKAI TAMOTSU		
发明人	KOYAMA, JUN TANAKA, YUKIO KUBOTA, YASUSHI SAKAI, TAMOTSU		
IPC分类号	G09G3/36 G02F1/1345 G02F1/136 G02F1/1362 G02F1/1368 H01L29/786		
CPC分类号	G02F1/1362 H01L27/124 G02F2001/13629 G09G3/3685 G09G2320/0209 G09G2320/0223 G09G2300/0426		
优先权	1997268148 1997-09-11 JP		
其他公开文献	US20020027543A1		
外部链接	Espacenet USPTO		

摘要(译)

一种液晶显示装置的驱动电路，包括：第一绝缘基板，其上设置有多条信号线和多条扫描线；以及像素晶体管，由薄膜晶体管制成，在这些线的交叉点处以矩阵形式设置；与第一绝缘基板相对的第二绝缘基板；液晶保持在第一和第二绝缘基板之间，其中驱动电路设置在第一绝缘基板上；用于向驱动电路提供时钟信号的时钟线的每个时钟线或基板部分由与薄膜晶体管的栅电极相同的布线材料和与源电极相同的布线材料的双层结构制成。或薄膜晶体管的漏电极；与时钟线或时钟线的基部交叉的布线由与覆盖像素晶体管的黑矩阵在同一层中的布线构成。

