



US 20080088758A1

(19) **United States**

(12) **Patent Application Publication**
Shie

(10) **Pub. No.: US 2008/0088758 A1**

(43) **Pub. Date: Apr. 17, 2008**

(54) **LIQUID CRYSTAL DISPLAY AND METHOD FOR MANUFACTURING THE SAME**

Publication Classification

(75) Inventor: **De-Ching Shie, Miao-Li (TW)**

(51) **Int. Cl.**
G02F 1/1333 (2006.01)
H01L 21/02 (2006.01)

Correspondence Address:
WEI TE CHUNG
FOXCONN INTERNATIONAL, INC.
1650 MEMOREX DRIVE
SANTA CLARA, CA 95050

(52) **U.S. Cl.** **349/40; 438/30; 257/E21.536**

(73) Assignee: **INNOLUX DISPLAY CORP.**

(57) **ABSTRACT**

(21) Appl. No.: **11/974,846**

(22) Filed: **Oct. 16, 2007**

(30) **Foreign Application Priority Data**

Oct. 16, 2006 (TW) 95138082

An exemplary liquid crystal panel (2) has a first substrate (21); a second substrate (23) opposite to the first substrate, which includes a conductive layer formed (233) thereat; a liquid crystal layer (25) sandwiched between the first and the second substrates, and a sealant (27) provided at the peripheral region of the first substrate and the second substrate. The conductive layer is adjacent to the liquid crystal layer, which remains the peripheral region of the second substrate uncovered.

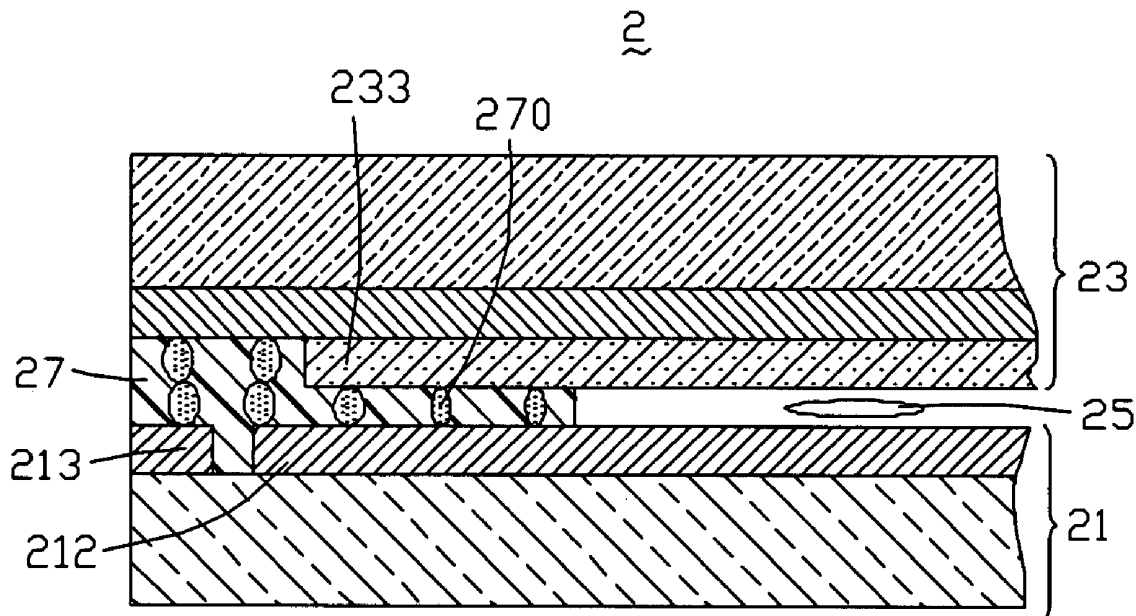

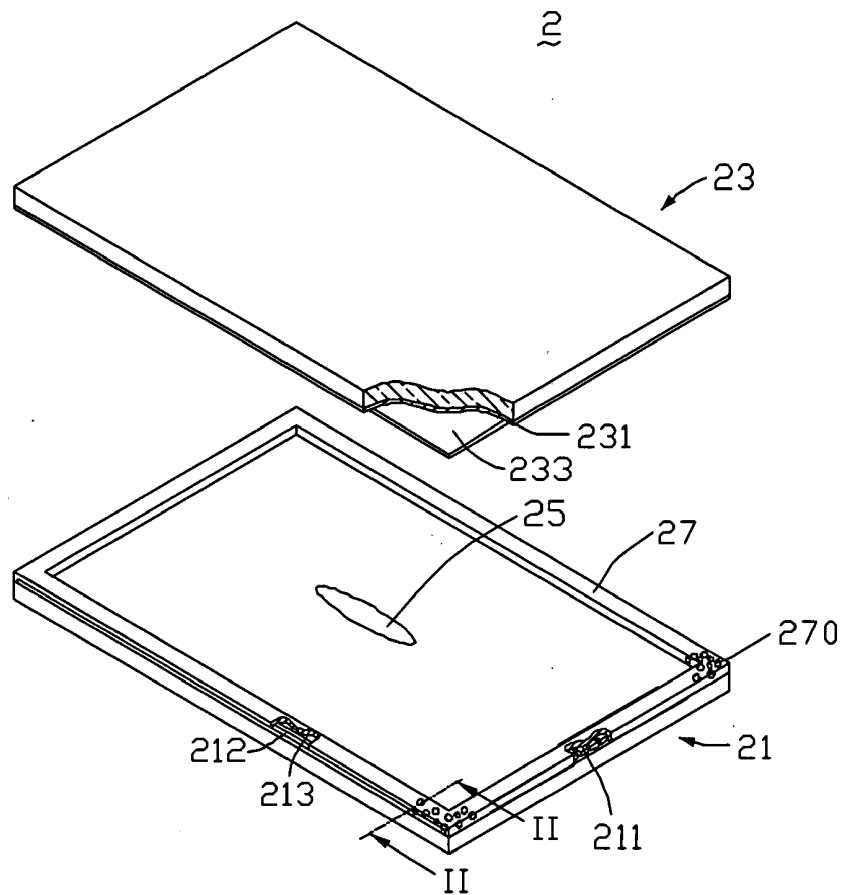

FIG. 1

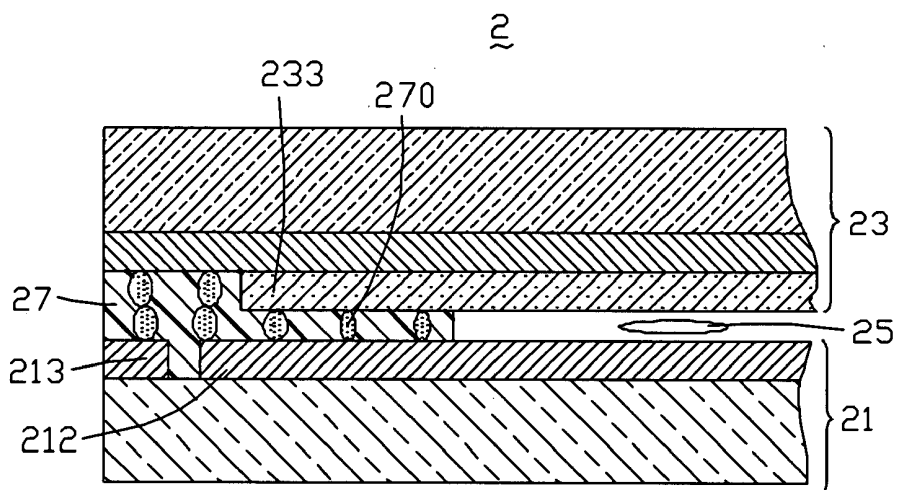

FIG. 2

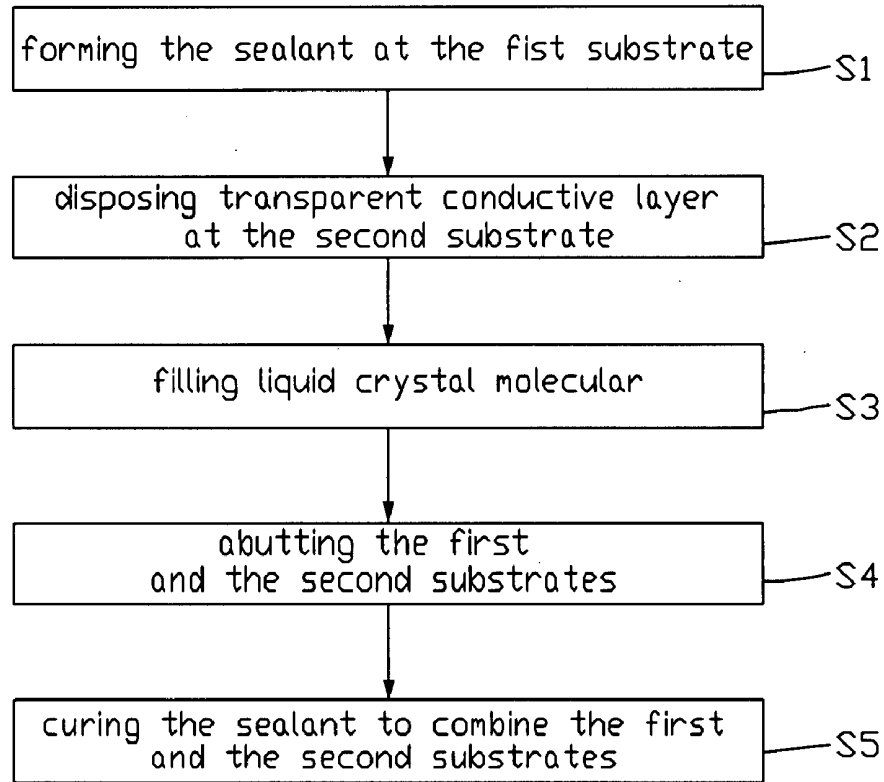

FIG. 3

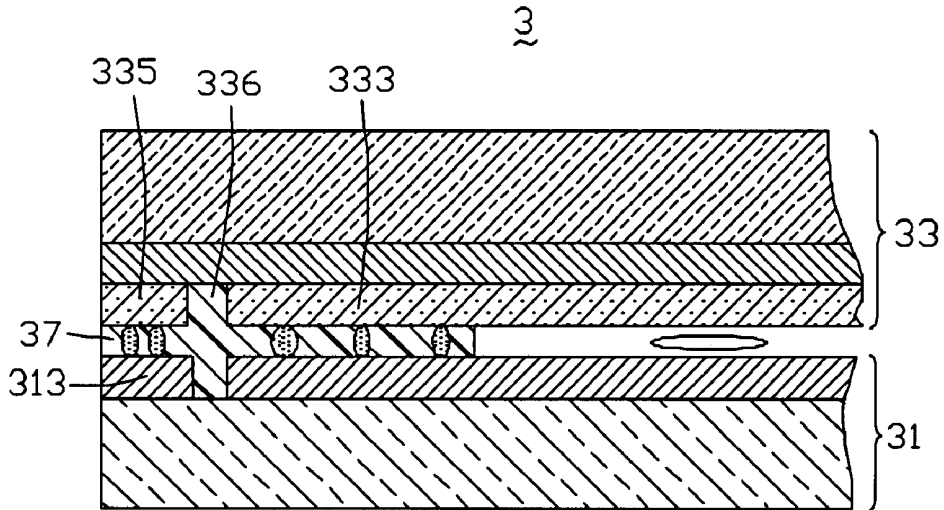

FIG. 4

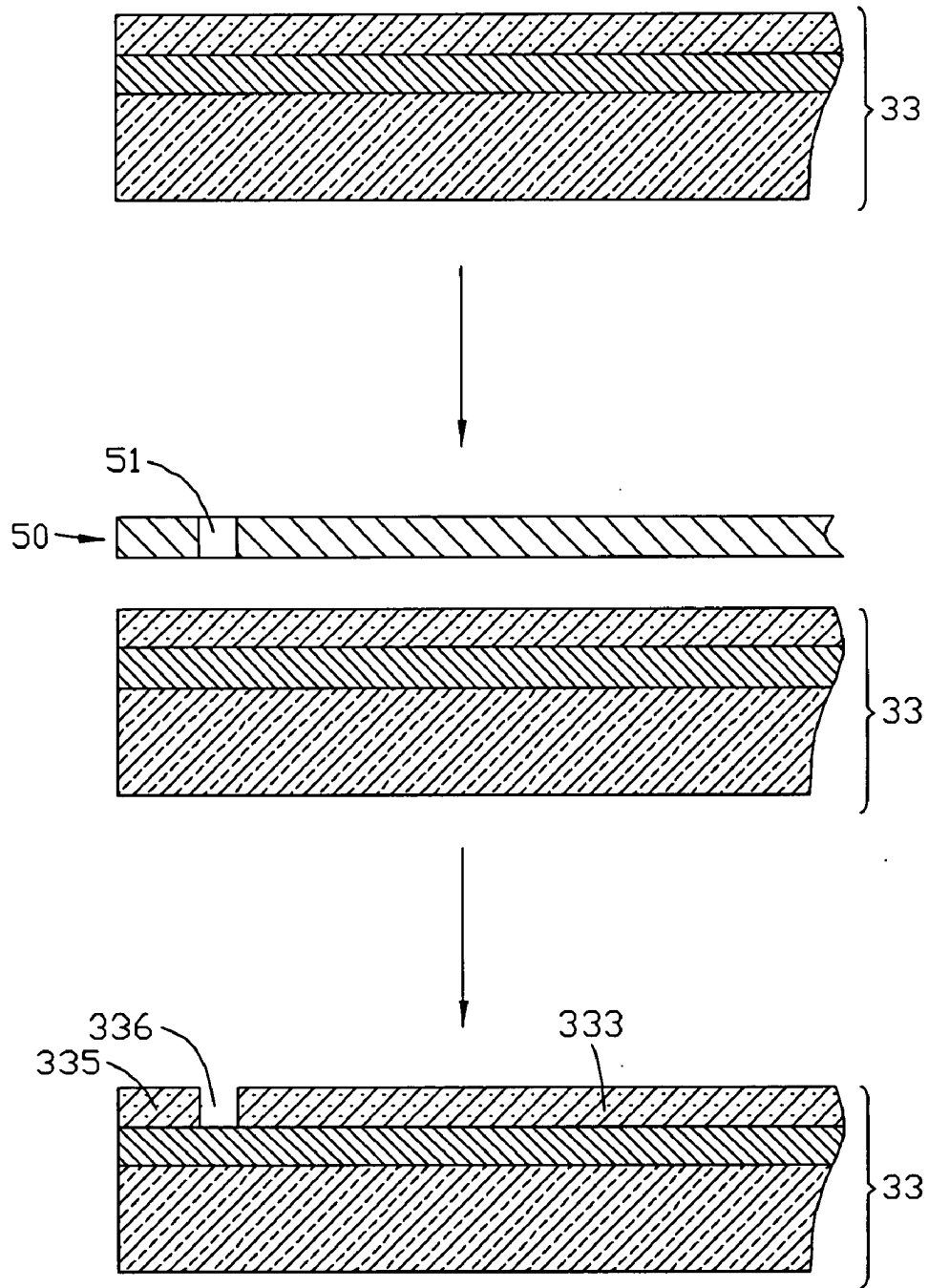

FIG. 5

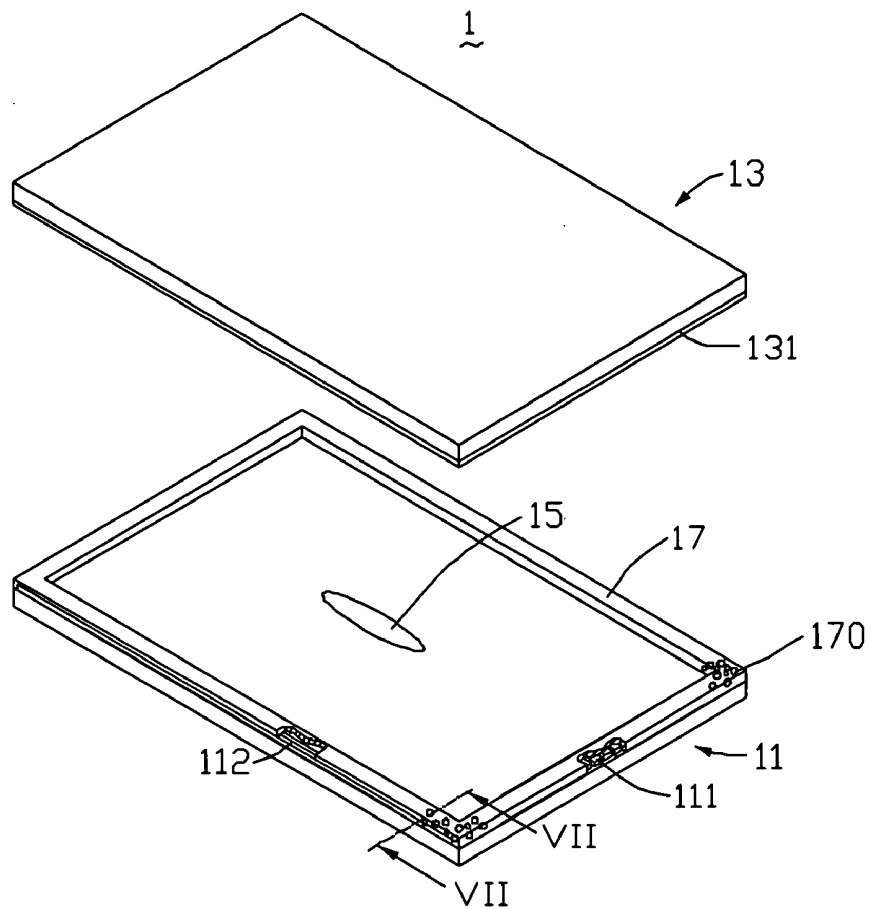

FIG. 6
(RELATED ART)

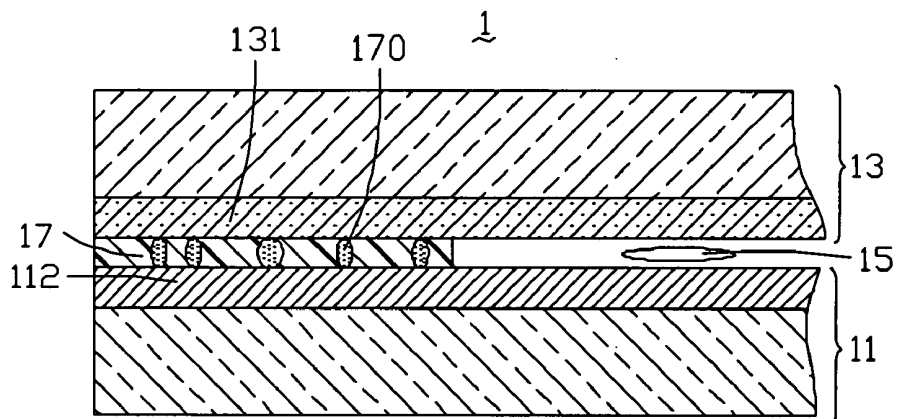

FIG. 7
(RELATED ART)

LIQUID CRYSTAL DISPLAY AND METHOD FOR MANUFACTURING THE SAME

FIELD OF THE INVENTION

[0001] The present invention relates to liquid crystal displays and method for manufacturing the same, and particularly to a liquid crystal panel preventing inner electrical elements from being damaged by the electro static, and a method for manufacturing the same.

GENERAL BACKGROUND

[0002] An LCD is capable of displaying a clear and sharp image through thousands or even millions of pixels that make up the complete image. The liquid crystal display has thus been applied to various electronic equipment in which messages or pictures need to be displayed, such as mobile phones and notebook computers. The liquid crystal display generally includes a liquid crystal panel for displaying images, and a backlight for illuminating the liquid crystal panel. The liquid crystal panel generally includes a thin film transistor (TFT) substrate, a color filter (CF) substrate, and a liquid crystal layer sandwiched between the two substrates. When a voltage is provided to the TFT substrate and the CF substrate, an electrical field is produced between the TFT substrate and the CF substrate to control the rotation of the liquid crystal molecular of the liquid crystal layer from realizing the image display.

[0003] As shown in FIG. 6 and FIG. 7, a typical liquid crystal panel 1 is shown. The liquid crystal panel 1 has a TFT substrate 11, a CF substrate 13, a liquid crystal layer 15, and a sealant 17 connecting and sealing the TFT substrate 11 and the CF substrate 13 to form an accommodating space to receive the liquid crystal layer 15. The TFT substrate 11 has a plurality of conductive metal lines 111 and a common electrode 112 formed at an inner surface thereof. The common electrode 112 is disposed at a peripheral region of the TFT substrate 11. The CF substrate 13 has a transparent conductive layer 131 formed at an inner surface thereof, which extends to an edge of the CF substrate 13 and covers the whole inner surface of the CF substrate 13. In addition, a plurality of conductive adhesive 170 is doped in the sealant 17, which electrically connect the common electrode 112 and the transparent conductive layer 131.

[0004] In operation, a voltage is provided on the TFT substrate 11 and the CF substrate 13, an electrical field is formed between the plurality of conductive metal lines III of the TFT substrate 11 and the transparent conductive layer 131 of the CF substrate 13. Liquid crystal molecular of the liquid crystal layer 15 rotates under the control of the electrical field to realize the image display.

[0005] However, the transparent conductive layer 131 extends to the edge of the CF substrate 13, and so the transparent conductive layer 131 of the CF substrate 13 can introduce the electro static into the liquid crystal panel 1, when an electro static discharge (ESD) phenomena produces. The electro static will damage the electrical elements in the liquid crystal panel 1, such as the conductive metal lines 111, driver IC (not shown), and etc.

[0006] Accordingly, what is needed is a liquid crystal panel and a method for manufacturing the same that can overcome the above-described deficiencies.

SUMMARY

[0007] In one preferred embodiment, an exemplary liquid crystal panel has a first substrate; a second substrate opposite to the first substrate, which includes a conductive layer formed thereat; a liquid crystal layer sandwiched between the first and the second substrates, and a sealant provided at the peripheral region of the first substrate and the second substrate. The conductive layer is adjacent to the liquid crystal layer, which remains the peripheral region of the second substrate uncovered.

[0008] In another preferred embodiment, an exemplary method of manufacturing a liquid crystal panel has following steps: providing a first and a second substrates; forming a conductive layer at the second substrate, which remains the peripheral region of the second substrate uncovered; attaching a sealant between the first and the second substrates to form a receiving space; and filling liquid crystal materials in the receiving space.

[0009] Other novel features and advantages will become more apparent from the following detailed description when taken in conjunction with the accompanying drawings.

BRIEF DESCRIPTION OF THE DRAWINGS

[0010] FIG. 1 is an exploded, isometric view of a liquid crystal panel according to a first embodiment of the present invention.

[0011] FIG. 2 is a partly, enlarged, side cross-sectional view of the liquid crystal panel of FIG. 1, corresponding to line II-II thereof.

[0012] FIG. 3 is a flow chart showing a method of manufacturing the liquid crystal panel of FIG. 1.

[0013] FIG. 4 is similar to FIG. 2, but essentially showing a corresponding view in the case of a liquid crystal panel according to a second embodiment of the present invention.

[0014] FIG. 5 shows the steps of manufacturing the liquid crystal panel of FIG. 4.

[0015] FIG. 6 is an exploded, isometric view of a conventional liquid crystal panel, and

[0016] FIG. 7 is a partly, enlarged, side cross-sectional view of the liquid crystal panel shown in FIG. 6, corresponding to line VII-VII thereof.

DETAILED DESCRIPTION OF PREFERRED EMBODIMENTS

[0017] Referring to FIGS. 1 and 2, aspects of a liquid crystal panel 2 according to a first embodiment of the present invention are shown. The liquid crystal panel 2 includes a first substrate 21, a second substrate 23, a sealant 27, and a liquid crystal layer 25. The first substrate 21 and the second substrate 23 are oriented opposite to each other. The sealant is sandwiched between the first and the second substrates 21, 23, at the peripheral region thereof, which defines an accommodating space to receive the liquid crystal layer 25 therein, cooperating with the first and the second substrates 21, 23. [0018] The first substrate 21 is a TFT substrate, which has a plurality of metal electrodes 211, a common electrode 212 and a ground electrode 213, formed at an inner surface thereof. The common electrode 212 and the ground electrode 213 are formed at the peripheral region of the first

substrate **21**, which are insulated to each other through a groove (not labeled). The second substrate **23** is a color filter substrate, which has a black matrix **231** and a transparent conductive electrode **233**, formed on an inner surface thereof in that order from top to bottom. The transparent conductive electrode **233** only covers a main part of the second substrate **23**, and remains the peripheral region of the second substrate **23** uncovered, that is the transparent conductive electrode **233** has an area smaller than that of the first substrate **21**.

[0019] A plurality of conductive adhesive particles **270** are doped in the sealant **27**, which electrically connect the common electrode **212** of the first substrate **21** and the transparent conductive electrode **233** for electrically conducting the first and the second substrates **21**, **23**.

[0020] In assembly, the first and the second substrates **21**, **23** are opposite to each other, and the sealant **27** is sandwiched therebetween, corresponding to the peripheral region of the first and the second substrates **21**, **23**. The sealant **27** encloses the transparent conductive electrode **233** and the common electrode **212** therein, and covers the ground electrode **213**. Thus, the transparent conductive electrode **233** and the common electrode **212** are not exposed in the external atmosphere.

[0021] In operation, a voltage is provided on the first substrate **21** and the second substrate **23**, an electrical field is produced between the plurality of conductive metal electrodes **211** of the first substrate **21** and the transparent conductive electrode **231** of the second substrate **23**. Liquid crystal molecular of the liquid crystal layer **25** rotates under the control of the electrical field to realize the image display.

[0022] Compare to the typical liquid crystal panel **1**, the transparent conductive electrode **233** of the liquid crystal panel **2** is enclosed by the sealant **27**, which is not exposed in the external atmosphere. So, the electro static being introduced to the enclosed transparent conductive electrode **233** can be avoided. Therefore, the inner electrical elements can be prevented from damaging by the electro static discharging phenomena.

[0023] Referring to FIG. 3, a flow chart of a method for manufacturing the liquid crystal panel **2** is shown. The method for fabricating the liquid crystal panel **2** includes the following steps.

[0024] In step S1, forming the sealant **27** at the first substrate **21**, the sealant **27** is applied at a periphery region of the inner surface of the first substrate **21** through a coating method or a spreading method.

[0025] In step S2, disposing the transparent conductive layer **233** on the second substrate **23**, the transparent conductive material is spread on the inner surface of the second substrate **23**, and then a margin of the transparent conductive material is etched to expose the peripheral of the second substrate **23**.

[0026] In step S3, filling liquid crystal molecular, the liquid crystal molecular is dropped in a space surrounded by the sealant **27** and the first substrate **21** to form the liquid crystal layer **25**. After then, a plurality of spacers (not shown) can be dispersed in the liquid crystal layer **25**.

[0027] In step S4, abutting the first and the second substrates, the second substrate **23** is loosely attached onto the first substrate **21**, and is pressed. So, the sealant **27** fills a gap between the transparent conductive layer **233** and the peripheral region of the second substrate **23** with the peripheral region of the first substrate **21**, which assures the electrical connection between the common electrode **212** of

the first substrate **21** and the transparent conductive layer **233** of the second substrate **23**.

[0028] In step S5, curing the sealant **27** to combine the first and the second substrates **21**, **23**, ultraviolet light or heat is used to cure the sealant **27** to realize the sealing of the liquid crystal panel **2**.

[0029] Further or alternative embodiments may include the following. In a second embodiment of the present invention, referring to FIG. 4, a liquid crystal panel **3** has a structure same to that of the liquid crystal panel **2** except that a transparent metal layer formed at a second substrate **33** is divided to a main part (not labeled) and a peripheral part (not labeled) surrounding the main part, by a groove **336**. The main part forms a transparent conductive layer **333**, and the peripheral part forms an electro static conductive layer **335**, insulated with the transparent conductive layer **333**. The electro static conductive layer **335** corresponds to a ground electrode **313** formed at a first substrate **31**. The electro static conductive layer **335** extends to an edge of the second substrate **33**. After assembly, the sealant **37** fills the groove **336** and encloses the transparent conductive layer **333** therein. Thus, the transparent conductive layer **333** is not exposed at the external atmosphere.

[0030] As shown in FIG. 5, the groove **336** can be formed by a photo-mask process. A light source (not shown) and a first photo-mask **50** are used to expose the transparent metal material. The photo-mask **50** is a slit mask, which has a slit region **51** and a shielding region (not labeled). The slit region **51** of the photo-mask **50** has a higher light transmittance ratio than the shielding region. Thus, light energy exiting from the slit region **51** is higher than that exiting from the shielding region. Then the transparent metal material is developed, thereby forming the transparent metal layer having the main part (not labeled) and the peripheral part (not labeled) surrounding the main part, by the groove **336**. The main part forms the transparent conductive layer **333**, and the peripheral part forms the electro static conductive layer **335**.

[0031] It is believed that the present embodiments and their advantages will be understood from the foregoing description, and it will be apparent that various changes may be made thereto without departing from the spirit and scope of the invention or sacrificing all of its material advantages, the examples hereinbefore described merely being preferred or exemplary embodiments of the invention.

What is claimed is:

1. A liquid crystal panel comprising:
 - a first substrate;
 - a second substrate opposite to the first substrate, which comprises a conductive layer formed thereat;
 - a liquid crystal layer sandwiched between the first and the second substrates, and
 - a sealant provided at the peripheral region of the first substrate and the second substrate;
 wherein the conductive layer is adjacent to the liquid crystal layer, which remains the peripheral region of the second substrate uncovered.
2. The liquid crystal panel as claimed in claim 1, wherein the sealant encloses the conductive layer in the liquid crystal panel.
3. The liquid crystal panel as claimed in claim 1, wherein the conductive layer is not exposed in the external atmosphere.

4. The liquid crystal panel as claimed in claim 1, further comprises an electro static conductive layer formed on the second substrate, surrounding and spacing the conductive layer.

5. The liquid crystal panel as claimed in claim 4, wherein the electro static conductive layer extends to an edge of the second substrate.

6. The liquid crystal panel as claimed in claim 4, wherein a groove is provided between the electro static conductive layer and the conductive layer.

7. The liquid crystal panel as claimed in claim 1, wherein the first substrate is a thin film substrate, which comprises a ground electrode formed in an inner surface of the first substrate.

8. The liquid crystal panel as claimed in claim 7, wherein the ground electrode corresponds to the electro static conductive layer.

9. The liquid crystal panel as claimed in claim 1, wherein the second substrate is a color filter substrate.

10. A method of manufacturing a liquid crystal panel comprising:

providing a first and a second substrates;
forming a conductive layer at the second substrate, which remains the peripheral region of the second substrate uncovered;

attaching a sealant between the first and the second substrates to form a receiving space; and
filling liquid crystal materials in the receiving space.

11. The method as claimed in claim 10, wherein the conductive layer is coated or spread on the second substrate.

12. The method as claimed in claim 10, further comprising a step of forming an electro static conductive layer on the second substrate, surrounding and spacing the conductive layer.

13. The method as claimed in claim 10, wherein the electro static conductive layer extends to an edge of the second substrate.

14. The method as claimed in claim 12, further comprising a step of a ground electrode formed in an inner surface of the first substrate.

15. The method as claimed in claim 14, wherein the ground electrode corresponds to the electro static conductive layer.

* * * * *

专利名称(译)	液晶显示器及其制造方法		
公开(公告)号	US20080088758A1	公开(公告)日	2008-04-17
申请号	US11/974846	申请日	2007-10-16
[标]申请(专利权)人(译)	群创光电股份有限公司		
申请(专利权)人(译)	群创光电股份有限公司.		
当前申请(专利权)人(译)	群创光电		
[标]发明人	SHIE DE CHING		
发明人	SHIE, DE-CHING		
IPC分类号	G02F1/1333 H01L21/02		
CPC分类号	G02F2001/133388 G02F1/1341		
优先权	095138082 2006-10-16 TW		
其他公开文献	US7760278		
外部链接	Espacenet USPTO		

摘要(译)

示例性液晶面板 (2) 具有第一基板 (21) ; 与第一基板相对的第二基板 (23) , 其包括在其上形成的导电层 (233) ; 夹在第一和第二基板之间的液晶层 (25) , 以及设置在第一基板和第二基板的周边区域的密封剂 (27) 。导电层与液晶层相邻 , 其保持第二基板的外围区域未被覆盖。

