



US006940564B2

(12) **United States Patent**
Murden et al.

(10) **Patent No.:** **US 6,940,564 B2**
(45) **Date of Patent:** **Sep. 6, 2005**

(54) **DISPLAY SUBSTRATE AND DISPLAY DEVICE**

6,427,017 B1 * 7/2002 Toki 381/190

(75) Inventors: **Vega Murden**, London (GB); **Peter W. Green**, Reigate (GB)

FOREIGN PATENT DOCUMENTS			
EP	0979992	2/2000 G01L/9/00
GB	2343811 A	5/2000 H04R/17/00
WO	WO0009440	2/2000 B81B/3/00
WO	WO0012428	3/2000 B81B/3/00

(73) Assignee: **Koninklijke Philips Electronics N.V.**, Eindhoven (NL)

OTHER PUBLICATIONS

(*) Notice: Subject to any disclaimer, the term of this patent is extended or adjusted under 35 U.S.C. 154(b) by 286 days.

“Piezoelectric Cantilever Microphone and Microspeaker”, Seung S. Lee et al., Journal of Microelectromechanical Systems, vol. 5, No. 4, Dec. 1996.

(21) Appl. No.: **10/099,758**

“Design and Fabrication of Silicon Condenser Microphone Using Corrugated Diaphragm Technique”, Quanbo Zou et al., Journal of Microelectromechanical System, vol. 5, No. 3, Sep. 1996.

(22) Filed: **Mar. 15, 2002**

* cited by examiner

(65) **Prior Publication Data**

US 2002/0135708 A1 Sep. 26, 2002

Primary Examiner—Tarifur R. Chowdhury

Assistant Examiner—David Y. Chung

(30) **Foreign Application Priority Data**

Mar. 23, 2001 (GB) 0107404

(57) **ABSTRACT**

(51) **Int. Cl.**⁷ **G02F 1/13**

A display substrate comprising a plate, for example a glass plate, on which display elements, e.g. pixels comprising pixel electrodes and thin-film-transistors, and an acoustic transducer, e.g. a microphone, speaker or buzzer, formed from thin film layers over a cavity, are formed. The cavity may be provided by powderblasting through the depth of the glass plate. The display substrate with integrated acoustic transducer may be incorporated in a display device, e.g. a liquid crystal display device. Also described is a discrete acoustic transducer, comprising a plate of an insulating material, a cavity in the plate, a plurality of layers that have been deposited on the plate, and a moveable member formed from the deposited layers and positioned over the cavity.

(52) **U.S. Cl.** **349/1; 381/190**

(58) **Field of Search** 349/1; 367/178, 367/179, 180, 181; 381/190; 257/59

(56) **References Cited**

U.S. PATENT DOCUMENTS

5,130,829 A	7/1992	Shannon	359/59
5,146,435 A *	9/1992	Bernstein	367/181
5,303,210 A *	4/1994	Bernstein	367/181
5,335,210 A	8/1994	Bernstein	367/163
5,452,268 A *	9/1995	Bernstein	367/181
5,940,015 A	8/1999	Thornton et al.	341/20
5,956,292 A *	9/1999	Bernstein	367/140

24 Claims, 7 Drawing Sheets

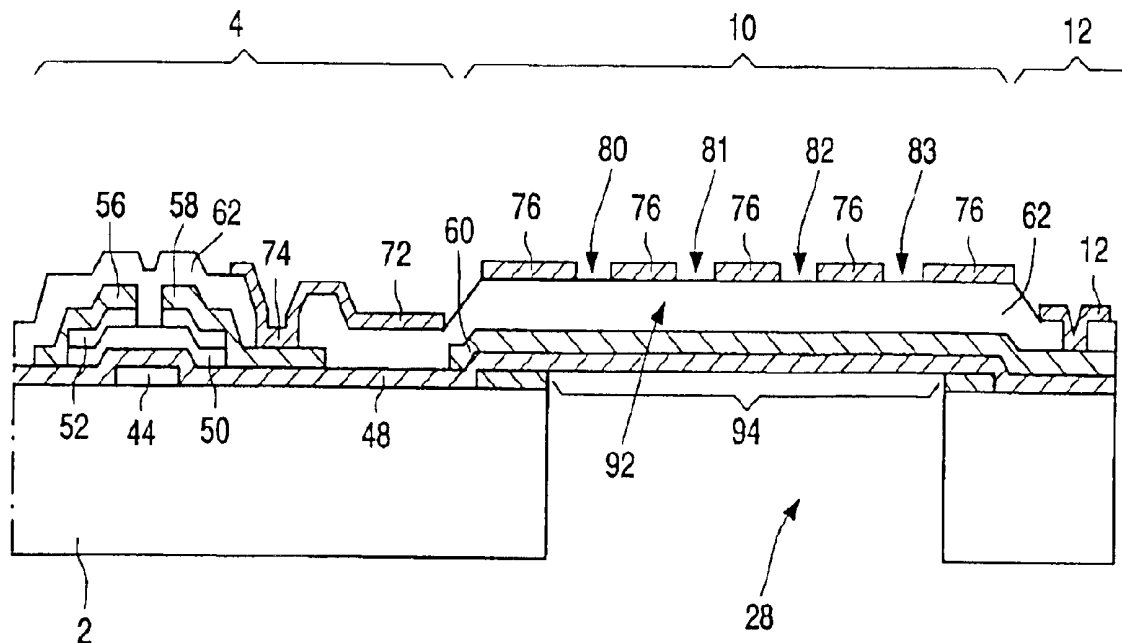

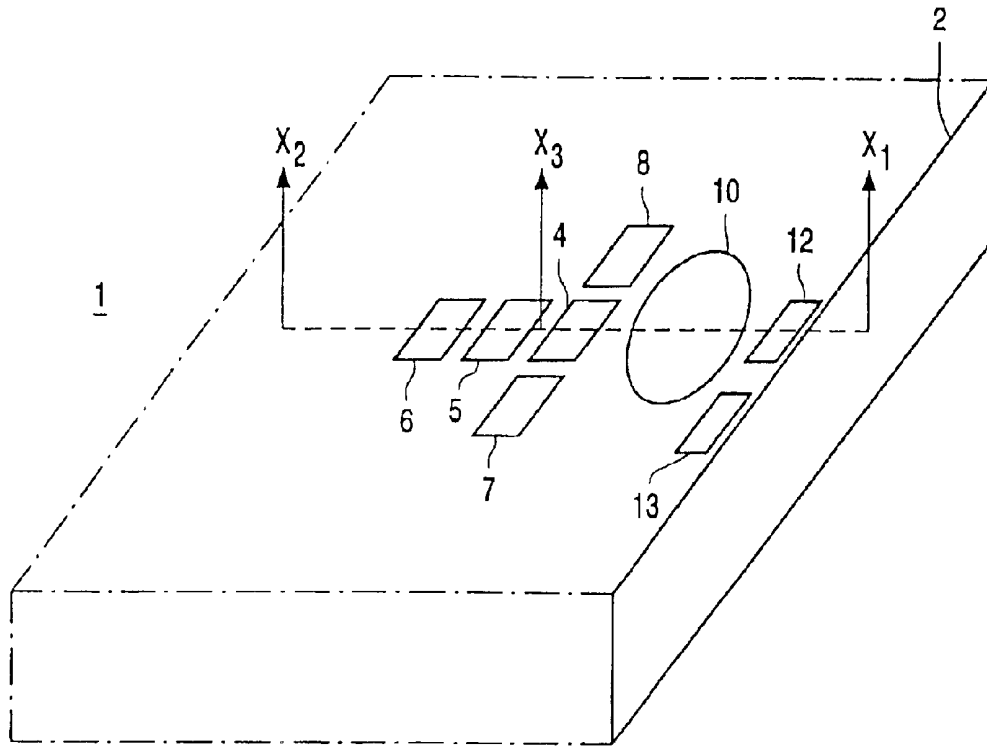

FIG. 1

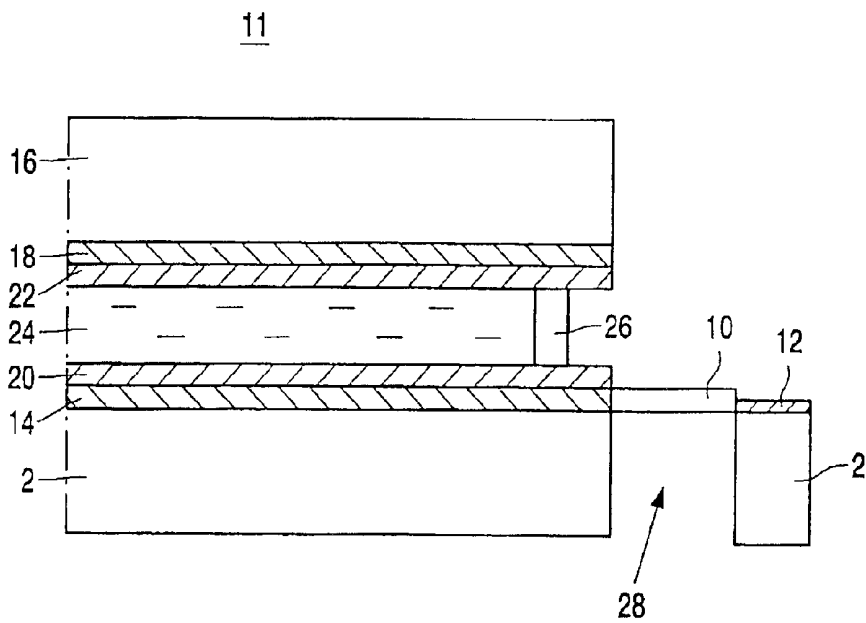

FIG. 2

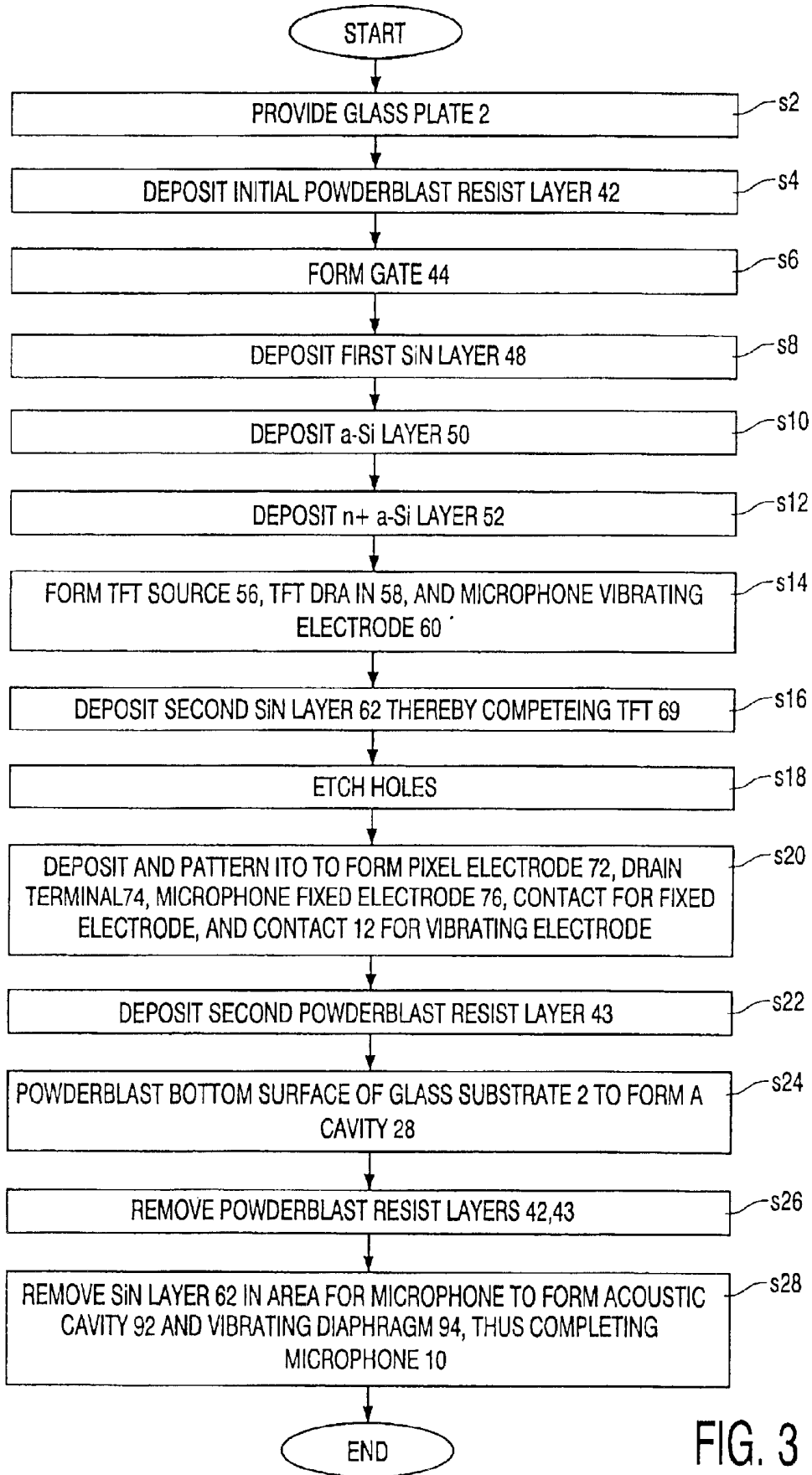

FIG. 3

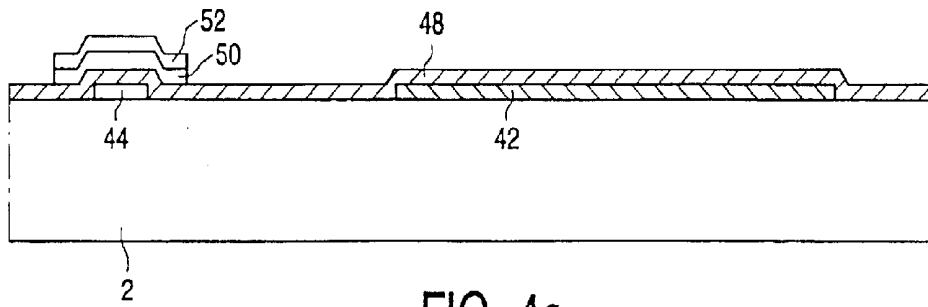

FIG. 4a

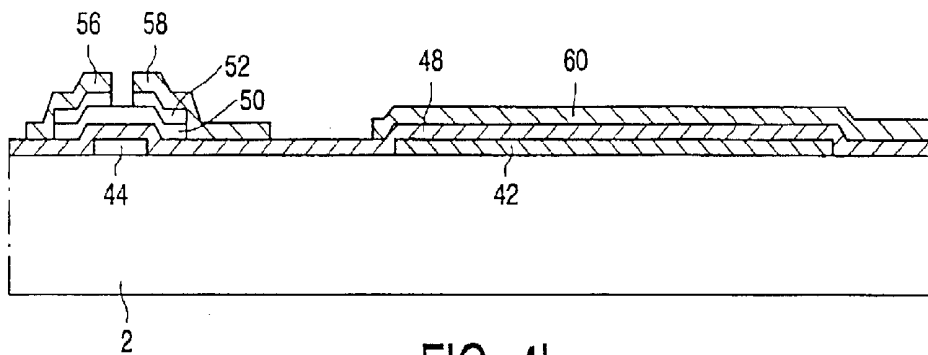

FIG. 4b

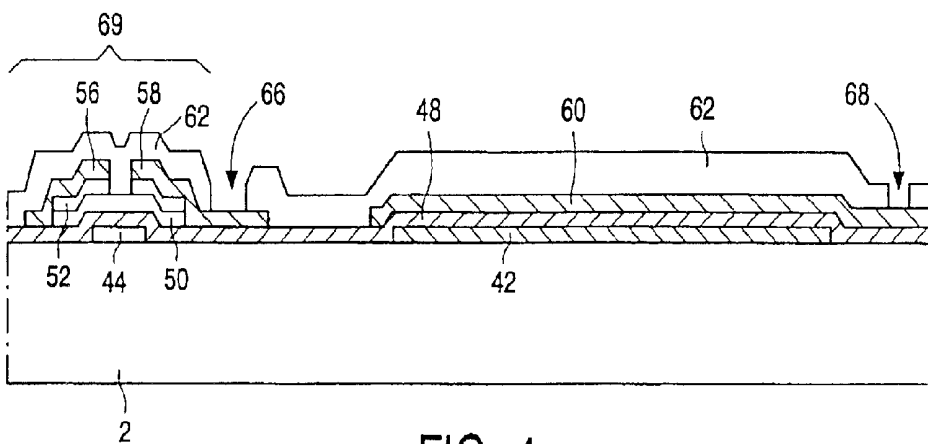

FIG. 4c

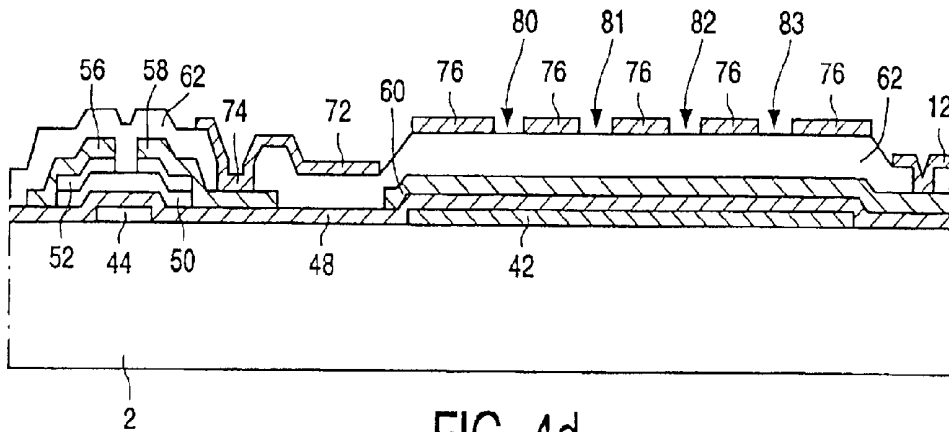

FIG. 4d

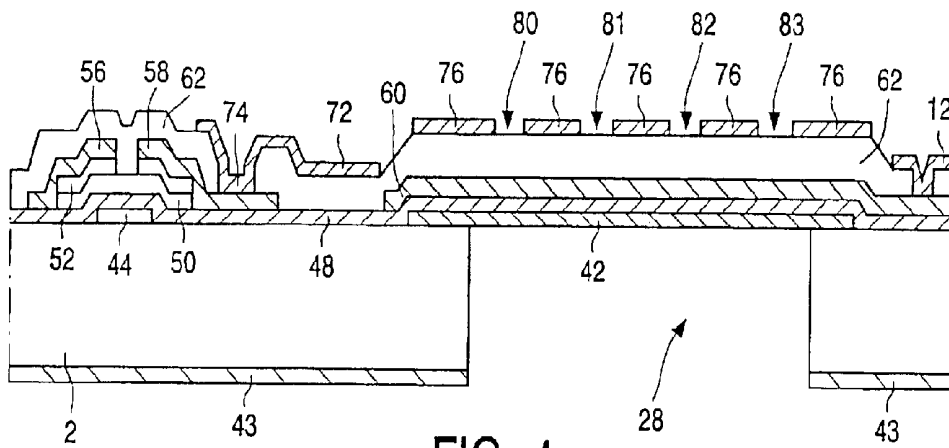

FIG. 4e

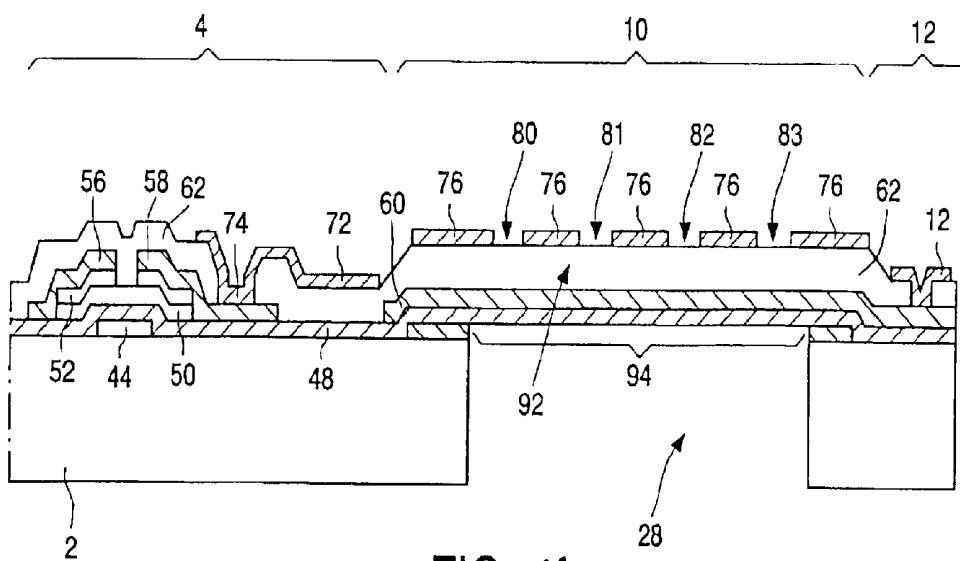

FIG. 4f

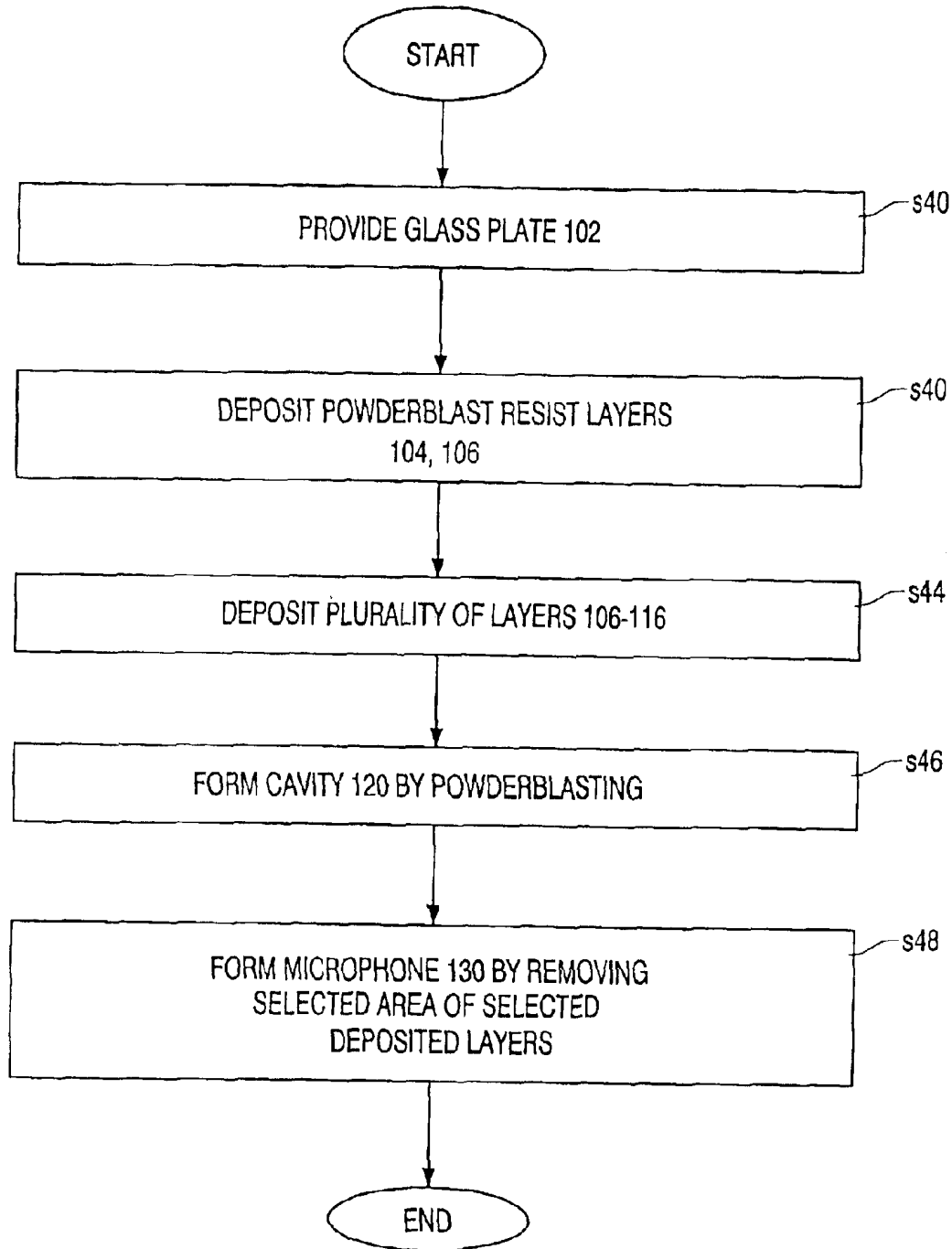

FIG. 5

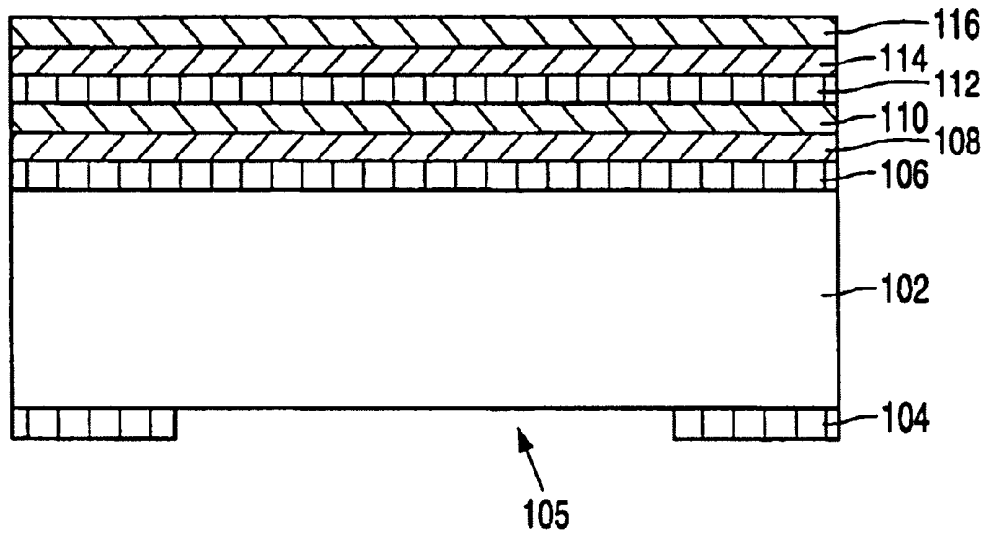

FIG. 6a

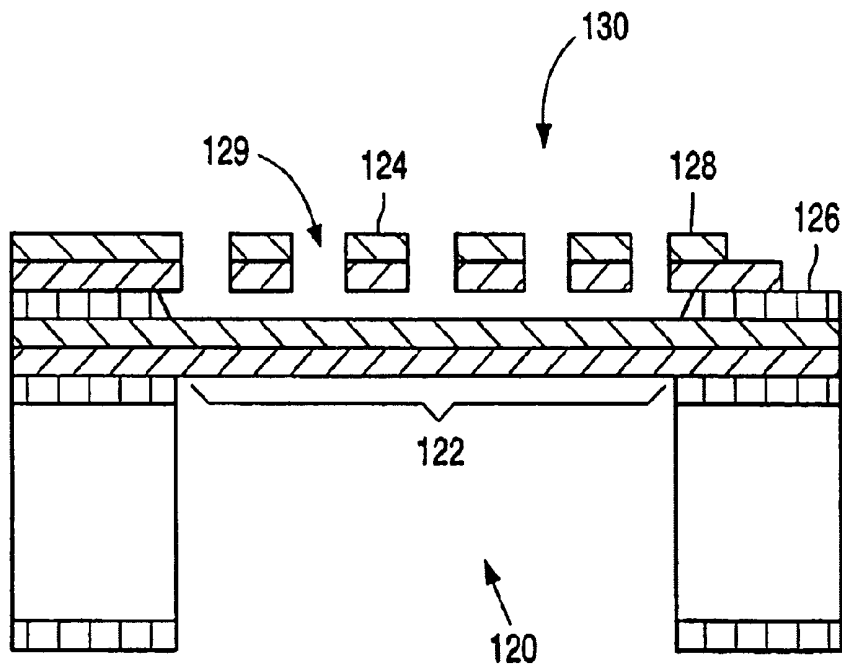

FIG. 6b

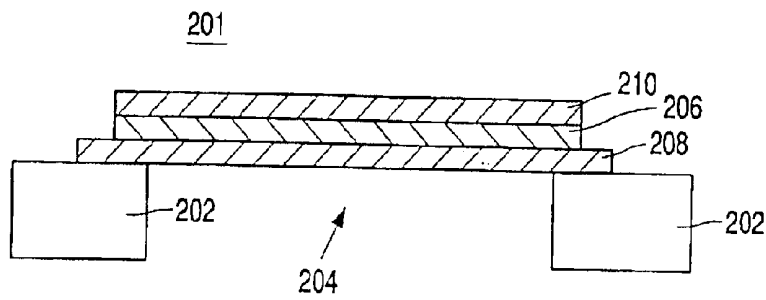

FIG. 7a

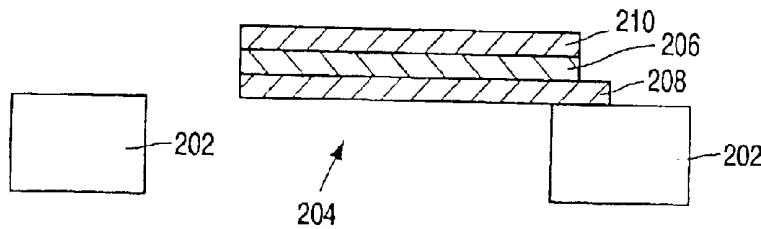

FIG. 7b

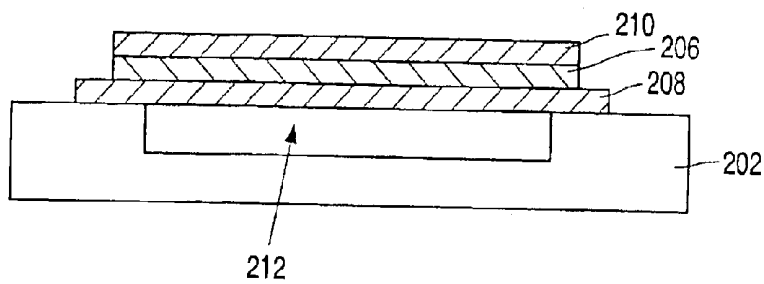

FIG. 7c

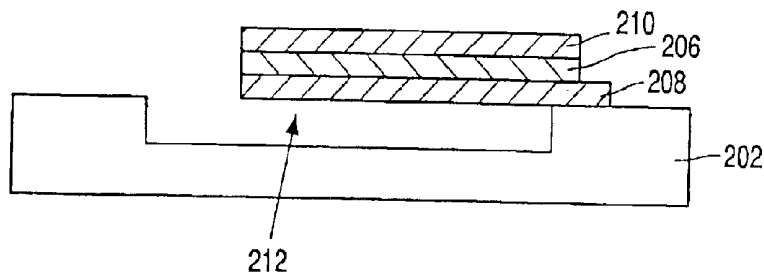

FIG. 7d

DISPLAY SUBSTRATE AND DISPLAY DEVICE

The present invention relates to display substrates, and display devices, for example liquid crystal display devices, incorporating display substrates. The present invention also relates to acoustic transducers.

Many electrical products, for example portable computers, personal organisers, and mobile telephones, include one or more display devices and one or more acoustic transducers.

Known display devices include liquid crystal, plasma, polymer light emitting diode, organic light emitting diode and field emission display devices. Such devices typically comprise two opposing display substrates with an electrically controllable light modulation layer or array between the two display substrates. The light modulation layer or array is provided either on one of the display substrates or in a gap between the two display substrates. A typical liquid crystal display device, with one of the display substrates having an active matrix of thin film transistors (TFTs) is disclosed in U.S. Pat. No. 5,130,829.

Examples of commonly used acoustic transducers are microphones, speakers and piezoelectric buzzers. Often electrical products require two or more acoustic transducers. For example, mobile telephones typically require a microphone for voice input, a speaker for audio output, e.g. speech, and a buzzer to attract a user's attention.

There is a trend for electrical products to provide increasing levels of functionality, and consequently more information is required to be displayed to users of the products. Hence larger area display devices are required. Conversely, however, there is a trend for products to be made smaller, especially in the case of portable equipment. For example, ever smaller mobile telephones require ever larger displays for purposes of displaying text messages and Internet content.

Consequently the space available for components such as acoustic transducers, in products also including display devices, is becoming increasingly scarce. A known solution for alleviating this problem is to provide and use smaller acoustic transducers. However, generally, as components are reduced in size, their unit production costs increase. Also, their assembly, connection and testing in an end product becomes more burdensome.

Considering, in isolation, the provision of small acoustic transducers, it is known within the field of acoustic transducers (quite separately from consideration of their use with display devices) to form acoustic transducer units using thin film layers deposited on silicon wafers. Such acoustic transducers are disclosed in "Design and Fabrication of Silicon Condenser Microphone Using Corrugated Diaphragm Technique", Quanbo Zou et al., *Journal of Microelectromechanical Systems*, Vol. 5, No. 3, September 1996; "Piezoelectric Cantilever Microphone and Microspeaker", Seung S. Lee et al., *Journal of Microelectromechanical Systems*, Vol. 5, No. 4, December 1996; and EP-A-0 979 992. Multiple acoustic transducers can be formed on each silicon wafer in conventional batch processing manner, and individual acoustic transducers thereafter formed by slicing of the wafer. The production techniques involved are often termed "micromachining".

These types of acoustic transducers can be produced in miniature form. The thin film layers can also be used to form integral semiconductor circuitry required for operation of the acoustic transducers. However, in products where space is at a premium due to the inclusion of one or more display devices, the use of such acoustic transducers would not fully resolve the problem of lack of space, because the packaging of each acoustic transducer would need its own space in the end product. Moreover, insertion and connection of the

acoustic transducer in the end product would be particularly burdensome due to the very miniaturisation advantage that such acoustic transducers might provide.

Overall, therefore, it is desirable to provide an alternative solution, other than simple reduction in size of acoustic transducers, to the problems described above.

In a first aspect, the present invention provides a display substrate, comprising: a plate; one or more display components formed on the plate; and an acoustic transducer formed on the plate over a cavity.

In a second aspect, the present invention provides a display device comprising a display substrate according to the first aspect.

The present invention derives from the idea of providing an integrated display and acoustic transducer by forming the acoustic transducer as an integrated part of one of the display substrates of a display device. Thus space can be saved in a product requiring both a display device and an acoustic transducer. Moreover, the requirement to separately insert and connect the acoustic transducer into an end product is removed as these operations occur when the display device is inserted and connected. This is particularly advantageous when the acoustic transducer is formed in miniature form on the substrate of the display device.

Preferably, the plate from which the display substrate is formed is of glass, quartz or a plastics material. This allows particularly economical display devices to be produced as such materials are commonly used as substrate materials for conventional display devices.

In a third aspect, the present invention provides a method of forming a display substrate, comprising: providing a plate; forming one or more display components on the plate; and forming an acoustic transducer on the plate over a cavity.

In a fourth aspect, the present invention provides a method of forming a display device, comprising forming a display substrate using a method according to the third aspect.

The cavity may be formed in the plate, in which case the cavity may extend through the whole depth of the substrate. Preferably, the cavity is produced by powderblasting, as this allows the provision of cavities in strong plate materials.

The cavity may alternatively be formed between the acoustic transducer and a surface of the plate, by the use of one or more sacrificial layers. This allows flexibility of design.

The joint provision of an acoustic transducer as well as one or more display elements on the same substrate allows process steps, in particular deposition and/or etching of various thin film layers, to be shared, thus simplifying the production process. The acoustic transducer may be a microphone or speaker, comprising a fixed electrode and a moveable diaphragm comprising a diaphragm electrode. In this case, the diaphragm electrode is preferably formed from a same layer of conductor as at least a first part of respective display elements formed on the display substrate. Further, the fixed electrode is preferably formed from a same layer of conductor as at least a second part of respective display elements formed on the display substrate. The moveable diaphragm may further comprise an insulation layer, in which case this insulation layer is preferably formed from a same insulation layer as at least a part of respective display elements, thus simplifying the production process. However, the insulation layer (or indeed any other layer) may be provided separately for the purpose of optimising the performance characteristics of the acoustic transducer and the display element individually.

Preferably the display substrate is an active matrix display substrate for a liquid crystal display device, and the display elements include thin-film transistors and pixel electrodes. In this case, the diaphragm electrode is prefer-

ably formed from a same layer of conductor as the gates of the thin-film transistors, and the fixed electrode is preferably formed from a same layer of conductor as the pixel electrodes.

When the display device is intended for an end product that requires more than one acoustic transducer, a plurality of acoustic transducers may be provided on one display substrate, thus multiplying the benefits derived from the present invention.

In a fifth aspect, the present invention provides an acoustic transducer, comprising: a substrate of an insulating material; a cavity in the substrate; a plurality of layers which have been deposited on the substrate; and a moveable member formed from the deposited layers and positioned over the cavity.

In a sixth aspect, the present invention provides a method of forming an acoustic transducer, comprising: providing a substrate of an insulating material; depositing a plurality of layers on the substrate; forming a cavity in the substrate; and forming, from the deposited layers, a moveable member positioned over the cavity.

Preferably, a fixed electrode is formed opposing the moveable member; the moveable member is formed from a moveable electrode formed from a first metal layer, the first metal layer being one of the plurality of layers, and an insulating layer, the insulating layer being another one of the plurality of layers; and the fixed electrode is formed from a second metal layer, the second metal layer being another one of the plurality of layers.

Preferably, the cavity is formed by powderblasting.

The fifth and sixth aspects are derived from the realization that acoustic transducers derived as part of the above mentioned first to fourth aspects of the present invention also provide potential benefits over known acoustic transducers even when not integrated as such on a display substrate. For example, by forming such acoustic transducers by depositing layers on an insulating substrate and forming a cavity in the insulating substrate, effective miniature acoustic transducers can be made from strong cheap substrate materials, thus reducing packaging and/or processing and/or material costs compared to the known silicon wafer based acoustic transducers discussed earlier above. Alternatively, or additionally, acoustic transducers according to the fifth and sixth aspects may, by virtue of their features common with display substrates, be provided such that their external physical form or packaging makes their incorporation into end products alongside display devices more straightforward than that of conventional acoustic transducers.

The dependent claims define, in addition to the various preferences discussed above, yet further preferences or possibilities of the present invention.

The above described and other aspects of the invention will be apparent from and elucidated with reference to the embodiments described hereinafter.

Embodiments of the present invention will now be described, by way of example, with reference to the accompanying drawings, in which:

FIG. 1 is a schematic illustration of part of a display substrate with an integrated microphone;

FIG. 2 is a schematic illustration of a cross-section of a liquid crystal display device comprising the display substrate illustrated in FIG. 1;

FIG. 3 is a flowchart showing process steps employed for producing the display substrate shown in FIGS. 1 and 2;

FIGS. 4a-f schematically illustrate the build-up of the features of the display substrate 1 as the process of FIG. 3 progresses;

FIG. 5 is a flowchart showing the process steps employed for producing a condenser microphone;

FIGS. 6a and 6b schematically illustrate the build-up of the features of the condenser microphone as the process of FIG. 5 progresses;

FIG. 7a is a schematic illustration of a piezoelectric buzzer comprising a diaphragm over a cavity;

FIG. 7b is a schematic illustration of a piezoelectric buzzer comprising a cantilever over a cavity;

FIG. 7c is a schematic illustration of another piezoelectric buzzer comprising a diaphragm over a cavity; and

FIG. 7d is a schematic illustration of another piezoelectric buzzer comprising a cantilever over a cavity.

It should be noted that the figures are diagrammatic and not drawn to scale. Relative dimensions and proportions of parts of these figures have been shown exaggerated or reduced in size, for the sake of clarity and convenience in the drawings.

FIG. 1 is a schematic illustration of part of a display substrate 1 provided in a first embodiment. The display substrate 1 comprises a glass plate 2. As with conventional display substrates, plural display elements are provided on the upper surface (as viewed in FIG. 1) of the glass plate 2. The term "display element" is used herein to refer to any item included as a part of a display substrate that contributes to the display functionality of the display substrate. In this embodiment, the plural display elements include an array of pixels. A large number of such pixels are provided, but for clarity only five of these, namely pixels 4, 5, 6, 7 and 8, are shown in FIG. 1.

A microphone 10, i.e. one type of acoustic transducer, is also provided on the upper surface of the glass plate 2. In this embodiment the shape of the microphone as viewed from above the upper surface of the glass plate 2 is approximately circular. The microphone 10 is a condenser microphone comprising a fixed electrode and a vibrating electrode. An external contact is provided for each of these microphone electrodes, i.e. contact 12 for the vibrating electrode and contact 13 for the fixed electrode. In operation of the microphone 10, the capacitance between the two electrodes varies as the vibrating electrode moves relative to the fixed electrode in response to sound waves. By connecting a suitable circuit to the two external contacts, this varying capacitance may be measured and processed.

The pixels 4, 5, 6, 7, 8 include TFTs and form an active matrix array such that the display substrate 1 may be used as an active matrix display substrate of a liquid crystal display device 11, as schematically illustrated in FIG. 2 where the display substrate 1 is shown in cross-section through the line X₁-X₂ of FIG. 1. In FIG. 2, the glass plate 2, the microphone 10 and the contact 12 are individually indicated. However, for clarity, the pixels 4, 5, 6 and any other display elements along the line X₁-X₂ are represented together as an active matrix layer 14 formed on the surface of the glass plate 2.

The glass plate 2 has a cavity 28 extending through the whole depth of the glass plate 2. The microphone 10 is formed over the cavity 28. The cavity 28 is of approximately circular cross-section, and this provides the approximately circular shape of the microphone 10, as will be explained in more detail below.

The contact 12 for the vibrating electrode is provided on the glass plate 2 next to the microphone 10 at a position outside of the area covered by the active matrix layer 14.

The area of the glass plate 2 that is covered by the active matrix layer 14 is used to form a liquid crystal display area as follows. The glass plate 2 has a liquid crystal orientation layer 20 deposited over the active matrix layer 14. The liquid crystal display device 11 further comprises a second glass plate 16, with a common electrode 18 thereon, spaced apart from the glass plate 2. The second glass plate 16 has a liquid crystal orientation layer 22 deposited over the common electrode 18. A liquid crystal layer 24, comprising twisted nematic liquid crystal material, is disposed between the orientation layers 20, 22 of the two glass plates 2, 16. A seal 26 is provided between the two orientation layers 20, 24 at the edge of the area of coverage of the liquid crystal layer 24.

These and other details of the liquid crystal display device (in so far as the area corresponding to the active matrix layer **14**, in contrast to the microphone **10**, is concerned) are the same, and operate the same, as the liquid crystal display device disclosed in U.S. Pat. No. 5,130,829, the contents of which are contained herein by reference.

Alternatively, the liquid crystal layer may extend over the microphone in order to simplify the production process, in which case the microphone will still respond to sound by virtue of vibrations passing through the liquid crystal layer, although this will usually have a detrimental affect on the quality of the microphone response.

FIG. **3** shows the process steps employed in this embodiment for producing the display substrate **1**. These process steps will now be described, with the aid of FIGS. **4a-f** which schematically illustrate the build-up of the features of the display substrate **1** as the process progresses. In FIGS. **4a-f**, the display substrate **1** is shown in terms of the cross-section through the line X_1-X_3 of FIG. **1**, i.e. to include the contact **12** for the vibrating electrode, the microphone **10**, and just the single pixel **4**. It will be appreciated however, that the procedures described below in relation to the pixel **4** are in fact performed at the same time for the whole array of pixels.

The features shown in FIG. **4a** are formed as follows. At step **s2**, the glass plate **2** is provided. At step **s4**, an initial powderblast resist layer **42** is deposited on the surface of the glass plate **2** over the area where the microphone **10** is to be provided. At step **s6**, a metal layer is deposited, and patterned to form a gate **44** where the TFT of the pixel **4** is to be formed. At step **s8**, a first silicon nitride (SiN) layer **48**, i.e. an insulation layer, is deposited over substantially the whole area of the glass plate **2**. At steps **s10** and **s12**, two amorphous silicon layers, for the TFT being formed, are deposited. More particularly, at step **s10** an undoped amorphous silicon layer **50** is deposited over the first SiN layer **48** above the gate **44**, followed at step **s12** by an n+amorphous silicon layer **52**, thus forming the overall structure shown in FIG. **4a**.

The additional features shown in FIG. **4b** are formed as follows. At step **s14**, a further metal layer is deposited and patterned to provide a source **56** and a drain **58** for the TFT being formed, and an electrode which will serve as the microphone vibrating electrode **60** of the microphone being formed. The n+amorphous silicon layer **52** is also removed in a small area over the gate **44**. Thus the overall structure shown in FIG. **4b** is arrived at.

The additional features shown in FIG. **4c** are formed as follows. At step **s16**, a second SiN layer **62**, i.e. insulation layer, is deposited over substantially the whole area of the glass plate **2**. By virtue of this, fabrication of the TFT **69** is essentially completed. At step **s18**, through holes are etched in the second SiN layer **62**, in particular a hole **66** over the drain **58**, and a hole **68** over an extended portion of the microphone vibrating electrode **60**. Thus the overall structure shown in FIG. **4c** is arrived at.

The additional features shown in FIG. **4d** are formed as follows. At step **s20**, a transparent electrode layer of indium tin oxide (ITO) is deposited over the second SiN layer **62** and the holes **64**, **66** and **68** therein, and patterned to form a pixel electrode **72**, a drain terminal **74** connecting the drain **58** of the TFT **69** to the pixel electrode **72**, an electrode which will serve as the microphone fixed electrode **76**, the microphone fixed electrode contact **13** mentioned earlier with reference to FIG. **1** (but not shown here in FIG. **4d** as it does not fall on the cross-section line X_1-X_3), and the contact **12** (mentioned earlier with reference to FIGS. **1** and **2**) for the microphone vibrating electrode **60**. In order that the microphone fixed electrode **76** will remain substantially stationary in operation whilst the earlier described microphone vibrating electrode **60** will vibrate, the ITO layer is

made thicker than the joint thickness of the first SiN layer **48** and the microphone vibrating electrode **60**, by an amount dependent on the relative stiffness of the materials involved. The microphone fixed electrode **76** is patterned such as to include gaps **80**, **81**, **82**, and **83** therein, such that when the microphone fixed electrode **76** is viewed from above it is in the form of a mesh. (When the microphone is completed, these gaps will form acoustic air holes, as will be described in more detail below.) Thus the overall structure shown in FIG. **4d** is arrived at.

The additional features shown in FIG. **4e** are formed as follows. At step **s22**, a second powderblast resist layer **43** is deposited over the whole area of the bottom surface of the glass plate **2** except for the area corresponding to where the microphone **10** is to be provided. In this embodiment the cavity is of diameter ~1 mm-2 mm, although generally this may be varied according to the required acoustic response of the microphone. At step **s24**, powderblasting, using iron pellets, is performed on the bottom surface of the glass plate **2**, to form a cavity **28** through the whole depth of the glass plate **2**. During the powderblasting process, the remaining area of the bottom surface of the glass plate **2** is protected by the second powderblast resist layer **43**. As the cavity nears completion, i.e. as the powderblasting works its way toward the underneath of the first SiN layer **48** in the area of the cavity, the first SiN layer **48** is protected by the first powderblast resist layer **42**. During the powderblasting process the top surface of the overall structure may optionally be protected by a layer, for example an organic photoresist, applied thereto before the powderblasting and removed by etching thereafter. In addition, the front side of the plate may be protected by, for example, a plate (e.g. metal) which is used to mount the glass plate during the powderblasting. Further details of the powderblasting process and powderblasting resists are given below. Thus the overall structure shown in FIG. **4e** is arrived at.

The additional features shown in FIG. **4f** are formed as follows. At step **s26**, the powderblast resist layers **42** and **43** are removed by etching. At step **s28**, the second SiN layer **62** is removed by etching in the area where the microphone **10** is to be provided. This leaves an acoustic cavity **92** between the microphone fixed electrode **76** and the microphone vibrating electrode **60**, and consequently the earlier mentioned gaps **80**, **81**, **82** and **83** form acoustic air holes connected to the acoustic cavity **92**. A further effect of the removal of the second SiN layer **62** in this area is to leave the first SiN layer **48** in the area over the cavity **28** and the microphone vibrating electrode **60** suspended over the cavity. In this way the microphone vibrating electrode **60**, and the portion of the first SiN layer **48** attached thereto, together form a vibrating diaphragm **94** of the microphone **10**. Furthermore, the removal of the second SiN layer **62** at step **s28** completes the formation of the microphone **10**, which comprises the microphone fixed electrode **76** and the vibrating diaphragm **94**, along with the acoustic cavity **92** and acoustic air holes **80**, **81**, **82** and **83** defined thereby.

In addition to the microphone **10**, other completed functional items indicated in FIG. **4f** are the pixel **4** and the microphone vibrating electrode contact **12**.

The pixel **4** comprises the pixel electrode **72** and its associated TFT **69**. The pixel **4** (and the other pixels, and other TFT connections such as gate leads, not shown, of the rest of the area of the glass plate **2**) constitute the display elements provided in the active matrix layer **14** and discussed earlier in relation to FIGS. **1** and **2**.

In this embodiment, the glass plate is of thickness 1 mm, although any convenient thickness may be used, and the various deposited layers are each of a thickness between 0.05 mm and 1 micron, as per standard TFT manufacturing processes, except for the second SiN layer **62** which in this example is 2 microns and the powderblast resist layers **42**

and 43. The powderblast resist layers 42 and 43 are discussed in more detail below. The thickness of the second SiN layer 62 defines the height of the acoustic chamber of the finished microphone, so will in fact be chosen in part according to the required acoustic response properties of the microphone. However, there is a trade-off with process costs in that thicker layers take longer to produce, and furthermore in this embodiment there is a trade-off with optimum TFT characteristics. Consequently, the thickness may be selected as desired in the light of these trade-offs.

Unless otherwise stated, all the layers are deposited in conventional fashion, and patterned and etched using standard photolithographic and etching techniques, as described for example in U.S. Pat. No. 5,130,829. Any further details of the parts of the display substrate 1 other than those related to the integrated inclusion of the microphone 10, (i.e. the pixel 4, the other pixels and gate leads and other external connections not shown, and other active matrix components not shown, such as row and column address conductors) are likewise provided and implemented in conventional fashion, again as described for example in U.S. Pat. No. 5,130,829.

The powderblasting process carried out at step s24 in the above process is an example of powderblasting and is a known process for mechanically removing solid material. Powderblasting, and powderblast resists, are discussed for example in the reference H. J. Lighthart, P. J. Slikkerveer, F. H. In't Veld, P. H. W. Swinkels and M. H. Zonneveld, Philips Journal of Research, Vol. 50, No. 3/4 p.475-499 (1996). Powderblasting is used for example to produce a rib-structure in the manufacture of some types of plasma display panels.

In this embodiment the second powderblast resist layer 43 is subjected to powderblasting throughout the powderblasting step s24, and hence is required to be a relatively strong and thick layer. The material used for the second powderblast resist 43 is Ebecryl 270™, (available from UCB Chemicals, Netherlands), which is a photosensitive elastomeric polymer based on polyurethane acrylate. This comes in liquid form and is applied using a doctor blade, giving a thickness of approximately 100 microns. This is patterned using photolithography. It will be appreciated that other polymers or mask materials may be used instead.

The first powderblast resist layer 42 is however only exposed to powderblasting toward the end of the powderblasting step s24 when the powderblasting has removed substantially all the thickness of the glass plate 2 in the cavity 28. It is therefore possible to use a thinner layer and/or weaker material for the first powderblast resist layer 42, and hence in this embodiment the material used is polyimide, and this is applied (at step s4) by spin coating to a few microns thickness and patterned using photolithography. This use of a thin polyimide layer is particularly compatible with the thin layers subsequently deposited thereon to form the microphone 10. As the polyimide is however not of optimum resistance with respect to powderblasting, the powderblasting step s24 is preferably carefully timed so that the polyimide layer is only exposed to the minimum powderblasting required to remove the glass from the cavity 28. In other embodiments, such careful timing (or equivalent process control) may be relaxed by employing a thicker and/or stronger material for the first powderblast resist layer 42, for example by using the same material as used for the second powderblast resist layer 43, although this provides a less compatible layer thickness.

Also, in other embodiments, powders other than iron pellets, for example glass beads, silica or alumina particles may be used. Also, other mechanical means for removing the glass to form the cavity 28 may be used instead of powderblasting.

Instead of the glass plate 2, a plate of some other material may be used, for example a quartz or plastic plate as used in

some liquid crystal display devices. A further possibility is a silicon plate, as used for example in so-called liquid crystal on silicon (LCOS) display devices.

The process described above for forming the TFT 69 is a standard six-mask bottom gate back channel etch, which provides an active matrix substrate for a transmissive display. Alternatively, other types of TFT may be employed (e.g. top gate, field shielded pixel, or bottom gate etch stop), some of which may use a reduced mask count. Further, the display substrate may be for a reflective or transmissive display, rather than a transmissive display. Yet further, the invention may be applied to other types of active matrix display substrates, for example ones using thin film diodes as opposed to TFTs.

One particular advantage of the above embodiment is that all the layers used to produce the microphone 10 are used in the formation of the TFT 69, thus simplifying the overall production process. However, in other embodiments, one or more of such layers may be deposited separately in the microphone area compared to the TFT area so that the thickness and/or choice of material may be optimised separately for the TFT and the microphone. This still advantageously shares process flow aspects.

In other embodiments the microphone may instead be integrated on the passive display substrate, i.e. the glass plate 16 that has the common electrode 18 thereon, rather than the active display substrate. Although this shares less process flow aspects, this will still provide, at least to a degree, the earlier described advantages with respect to saving space etc. in an end product requiring a display device and an acoustic transducer. Likewise, in other embodiments the microphone may be integrated on a display substrate of a liquid crystal display device in which both display substrates are of the passive type, i.e. a passive matrix liquid crystal display.

It will be appreciated that the present invention may be also be applied to any type of display device that includes a suitable display substrate. This includes, inter alia, the following: a plasma display device; a field emission display device; a polymer light emitting diode display device; and an organic light emitting diode display device. In the case of a plasma display device, efficiencies in the production process may be achieved if powderblasting is already used in the production process of the plasma display device.

In the above embodiment the shape of the microphone as viewed from above the glass plate is substantially circular. Since the shape is merely defined by masks (i.e. photoresist and powderblast resist) other shapes may be used as required, which represents an advantage of the use of powderblasting.

Other types of microphone, for example an electret microphone, may be provided instead of the condenser type microphone of the above embodiment.

The microphone provided in the above embodiment may also be used, i.e. constitute, a speaker, if it is excited by application of an electrostatic field between the two electrodes thereof. By varying the electrostatic field (i.e. by varying an alternating voltage applied between the two electrodes) movement of the vibrating diaphragm is achieved thus producing the required sound. In other embodiments, a piezoelectric buzzer may be provided on the display substrate instead of a microphone.

In further embodiments, instead of a single acoustic transducer, more than one acoustic transducer, comprising any combination of single or plural microphones, speakers or piezoelectric buzzers, may be formed on the display substrate.

The thin film layers used for the display elements and the acoustic transducer(s) may also be used to produce integral semiconductor circuitry required for operation of the acoustic transducer.

In the main embodiment described above, processing efficiency is achieved by virtue of forming the display elements and the acoustic transducer in parallel as the display substrate is built up on the glass plate. As already mentioned, if it is desired to optimise one or more layers separately for the display elements or the acoustic transducer, then individual layers may be deposited or processed separately in the respective areas, with the other area either being masked from deposition or having unnecessary layers removed therefrom. However, in some circumstances overall production may be more efficient if the acoustic transducer and the display elements are provided on the display substrate in quite separate processes, i.e. the display elements are formed first, and then the acoustic transducer, or vice-versa. This may be the case, for example, where a standard design of display area is required to be combined with various types, numbers, sizes, or positions of acoustic transducers.

Furthermore, discrete acoustic transducers may be provided by forming just the acoustic transducer part of the above embodiments, without display elements.

Further embodiments that are particularly suited to separate formation of the acoustic transducer will now be described with reference to FIGS. 5 to 7. It will be appreciated that, in the same way as with the embodiments of FIGS. 1 to 4, the embodiments of FIGS. 5 to 7 allow the provision of acoustic transducers on display substrates (with display elements added either previously or afterwards), as well as the provision of separate discrete acoustic transducers by forming just the acoustic transducer part to be described, without display elements.

FIG. 5 shows the process steps employed in a further condenser microphone embodiment. These process steps will now be described, with the aid of FIGS. 6a and 6b which schematically illustrate the build-up of the features of the microphone.

The features shown in FIG. 6a are formed as follows. At step s40, a glass plate 102, of thickness 0.7 mm, is provided. At step s42 a bottom powderblast resist layer 104 is deposited on the bottom surface of the glass plate 102 and patterned with a gap 105 in the area corresponding to where the microphone is to be provided, and a top powderblast resist layer 106 is deposited on the top surface of the glass plate 102. In this embodiment, both the powderblast resist layers 104, 106 are of Ebecryl 270™ (available from UCB Chemicals, Netherlands) which was discussed earlier in relation to the first main embodiment, and of a thickness of about 100 microns. Furthermore, in the present embodiment, the possibilities and influences of the choice of powderblast resist are the same as in the first main embodiment. At step s44, various layers are successively deposited on the top surface of the glass plate 102, each to a thickness of between 0.05 mm and 1 microns (but as in the other embodiments, the thicknesses may of course be varied as required). The layers are, in order of deposition, a first SiN layer (i.e. insulating layer) 108, a bottom chromium layer 110 (to serve as a conductor), an aluminium layer 112 (which will serve as a sacrificial layer), a second SiN layer (i.e. insulating layer) 114, and a top chromium (or other metal) layer 116 (to serve as a conductor). Thus the overall structure shown in FIG. 6a is arrived at.

The additional features shown in FIG. 6b are formed as follows. At step s46, powderblasting is performed to provide a cavity 120 is provided in the glass plate, extending the whole depth of the glass plate 102, in the area where the diaphragm of the microphone is to be provided. At step s48, various layers are removed in selected areas i.e. the remaining powderblast resist from the top powderblast resist layer 106 at the area of the cavity 120; the sacrificial aluminium layer 112 in this area; and selected areas in the second SiN layer 114 and the top metal layer 116 (for providing acoustic

air holes and electrical contacts to underlying layers). This results in a completed microphone 130, comprising a vibrating diaphragm 122 (the vibrating diaphragm 122 comprising the first SiN layer 108 and the bottom chromium layer 110 in the area over the cavity 120), a fixed electrode structure 124 (the fixed electrode structure 124 comprising the top metal layer 116 and the second SiN layer 114 in the area over the diaphragm 122, and further comprising acoustic air holes 129 therein), a contact 128 for the fixed electrode and a contact 126 for the vibrating electrode.

As described with respect to the microphone of the first main embodiment, the structure of FIG. 6b may also be used to provide a speaker rather than a microphone.

In all of the above embodiments, the cavity over which the vibrating diaphragm is located is formed by removing material from the glass plate (e.g. glass plate 2 or glass plate 102). In other embodiments, the cavity may be formed instead by providing one or more sacrificial layers between the glass plate and the layers that will form the vibrating diaphragm, then removing the sacrificial layer(s) to produce the cavity in the space vacated by the sacrificial layer(s). Any appropriate material may be used for the sacrificial layer(s), including for example SiN, Al, or organic material such as photoresist.

In a further embodiment, an acoustic transducer comprising a piezoelectric buzzer, schematically illustrated in FIG. 7a, is provided. The piezoelectric buzzer 201 comprises a glass plate 202 with a cavity 204, of rectangular area, sized as required for acoustic properties, in this example approximately 10 mm×10 mm, formed therein by powderblasting such as to extend through the whole depth of the glass plate 202.

A square shaped plate of piezoelectric material 206, in this embodiment lead zirconate titanate (PZT) of thickness as required for acoustic properties, in this example of the order of 100 microns, and of approximate area 10 mm×10 mm, is provided with electrodes 208 and 210 on the top and bottom surfaces thereof. The plate of piezoelectric material 206 is bonded to the glass plate 202, over the cavity 204, thereby providing the piezoelectric transducer 201. In this embodiment the plate of piezoelectric material 206 is bonded to the glass plate 202 along substantially the whole of the perimeter of its square area, thereby forming a diaphragm.

The plate of piezoelectric material 206 may alternatively be made slightly smaller than the area of the cavity 204, and bonded along only one side thereof, thereby forming a cantilever, as shown in FIG. 7b.

The diaphragm or cantilever may alternatively be provided over a cavity 212, again produced by powderblasting, that differs from the cavity 204 in that it only extends through some of the depth of the glass plate 202, as shown in FIG. 7c (for the diaphragm) and FIG. 7d (for the cantilever).

The plate of piezoelectric material 206 with electrodes thereon may conveniently be provided by applying a plurality of electrodes over respective areas of a larger sheet of piezoelectric material and then cutting the processed sheet into individual electrode coated plates 206.

The cavity 204, 212 and plate of piezoelectric material 206 may be formed in shapes other than square.

The piezoelectric buzzer 201 is operated by applying an alternating voltage between the two electrodes 208, 210.

It will be appreciated that the above examples of provision of display substrates (e.g. liquid crystal display substrates) and acoustic transducers (e.g. microphones) are described by way of example only, and that the invention may be applied to the provision of any other appropriate type of display substrate and/or acoustic transducer. Likewise, layer characteristics, such as type of material and thickness, are merely exemplary.

11

From reading the present disclosure, other variations and modifications will be apparent to persons skilled in the art. Such variations and modifications may involve equivalent and other features which are already known in the design, manufacture and use of display devices and acoustic transducers, and which may be used instead of or in addition to features already described herein.

Although Claims have been formulated in this Application to particular combinations of features, it should be understood that the scope of the disclosure of the present invention also includes any novel feature or any novel combination of features disclosed herein either explicitly or implicitly or any generalisation thereof, whether or not it relates to the same invention as presently claimed in any Claim and whether or not it mitigates any or all of the same technical problems as does the present invention. Features which are described in the context of separate embodiments may also be provided in combination in a single embodiment. Conversely, various features which are, for brevity, described in the context of a single embodiment, may also be provided separately or in any suitable subcombination. The Applicants hereby give notice that new Claims may be formulated to such features and/or combinations of such features during the prosecution of the present Application or of any further Application derived therefrom.

What is claimed is:

1. A display substrate, comprising:
a plate;
at least one display element formed on the plate; and
an acoustic transducer formed on the plate over a cavity;
wherein the cavity is formed in the plate.
2. A display substrate according to claim 1, wherein the acoustic transducer is a microphone or a speaker, and comprises a fixed electrode and a diaphragm comprising a vibrating electrode.
3. A display substrate, comprising:
a plate;
at least one display element formed on the plate; and
an acoustic transducer formed on the plate over a cavity;
wherein
the acoustic transducer is a microphone or a speaker, and
comprises a fixed electrode and a diaphragm comprising a vibrating electrode, and
the vibrating electrode is formed from a same layer of conductor as at least a
first part of the one or more display elements.
4. A display substrate, comprising:
a plate;
at least one display element formed on the plate; and
an acoustic transducer formed on the plate over a cavity;
wherein
the acoustic transducer is a microphone or a speaker, and
comprises a fixed electrode and a diaphragm comprising a vibrating electrode, and
the fixed electrode is formed from a same layer of conductor as at least a second part of the one or more display elements.
5. A display substrate according to claim 2, wherein the diaphragm further comprises an insulation layer.
6. A display substrate according to claim 5, wherein the insulation layer of the diaphragm is formed from a same insulation layer as at least a part of the at least one display component.
7. A display substrate according to claim 3, wherein the cavity is between the acoustic transducer and a surface of the plate.

12

8. A display substrate according to claim 3, wherein the cavity is formed in the plate.
9. A display substrate according to claim 1, wherein the cavity extends the whole depth of the plate.
10. A display substrate according to claim 1, wherein the cavity is a powderblasted cavity.
11. A display substrate, comprising;
a plate;
at least one display element formed on the plate; and
an acoustic transducer formed on the plate over a cavity;
wherein
the at least one display element forms an active matrix array such that the display substrate is an active matrix substrate for a liquid crystal display device.
12. A display substrate according to claim 11 wherein the active matrix array comprises thin-film-transistors and the vibrating electrode is formed from a same layer of conductor as the gates of the thin-film-transistors.
13. A display substrate according to claim 11, wherein the active matrix array comprises pixel electrodes and the fixed electrode is formed from a same layer of conductor as the pixel electrodes.
14. A display substrate according to claim 8, wherein the at least one display element is a common electrode such that the display substrate is a passive substrate for a liquid crystal display device.
15. A display substrate according to claim 3, wherein the at least one display element forms an active matrix array such that the display substrate is an active matrix substrate for a liquid crystal display device.
16. A display substrate according to claim 15, wherein the active matrix array comprises thin-film-transistors and the vibrating electrode is formed from a same layer of conductor as the gates of the thin-film-transistors.
17. A display substrate according claim 4, wherein the at least one display element forms an active matrix array such that the display substrate is an active matrix substrate for a liquid crystal display device.
18. A display substrate according to claim 17, wherein the active matrix array comprises thin-film-transistors and the vibrating electrode is formed from a same layer of conductor as the gates of the thin-film-transistors.
19. A display substrate according to claim 17, wherein the active matrix array comprises pixel electrodes and the fixed electrode is formed from a same layer of conductor as the pixel electrodes.
20. A display substrate according to claim 4, wherein the cavity is between the acoustic transducer and a surface of the plate.
21. A display substrate according to claim 4, wherein the cavity is formed in the plate.
22. A display substrate according to claim 11, wherein the acoustic transducer is a microphone or a speaker, and comprises a fixed electrode and a diaphragm comprising a vibrating electrode.
23. A display substrate according to claim 11, wherein the cavity is between the acoustic transducer and a surface of the plate.
24. A display substrate according to claim 11, wherein the cavity is formed in the plate.

专利名称(译)	显示基板和显示装置		
公开(公告)号	US6940564	公开(公告)日	2005-09-06
申请号	US10/099758	申请日	2002-03-15
[标]申请(专利权)人(译)	皇家飞利浦电子股份有限公司		
申请(专利权)人(译)	皇家飞利浦电子N.V.		
当前申请(专利权)人(译)	皇家飞利浦电子N.V.		
[标]发明人	MURDEN VEGA GREEN PETER W		
发明人	MURDEN, VEGA GREEN, PETER W.		
IPC分类号	G02F1/13 G02F1/1333 H04R19/04 H04R1/28 H04R19/00 H04R17/02 H04R19/01 G02F1/1368 G09F9/00 G09F9/35		
CPC分类号	G02F1/1333 H04R17/02 H04R19/005 H04R31/00 G02F1/133308 H04R19/016		
助理审查员(译)	CHUNG , DAVID Y.		
优先权	2001007404 2001-03-23 GB		
其他公开文献	US20020135708A1		
外部链接	Espacenet USPTO		

摘要(译)

一种显示基板，包括板，例如玻璃板，其上具有显示元件，例如玻璃板。包括像素电极和薄膜晶体管的像素，以及声换能器，例如，形成由腔上的薄膜层形成的麦克风，扬声器或蜂鸣器。可以通过玻璃板的深度粉末喷射来提供空腔。具有集成声换能器的显示基板可以结合在显示装置中，例如显示装置。液晶显示装置。还描述了一种离散声换能器，包括绝缘材料板，板中的腔，已经沉积在板上的多个层，以及由沉积层形成并定位在腔上方的可移动构件。

